

Grizzly *Industrial, Inc.* ®

15" PLANER **MODEL G1021** **INSTRUCTION MANUAL**



COPYRIGHT © 1986 BY GRIZZLY INDUSTRIAL, INC. REG.# TX 3 170 572
**WARNING: NO PORTION OF THIS MANUAL MAY BE REPRODUCED IN ANY SHAPE
OR FORM WITHOUT THE WRITTEN APPROVAL OF GRIZZLY INDUSTRIAL, INC.**
REVISED FEBRUARY, 1999. PRINTED IN U.S.A



WARNING!

Some dust created by power sanding, sawing, grinding, drilling, and other construction activities contains chemicals known to the State of California to cause cancer, birth defects or other reproductive harm. Some examples of these chemical are:

- Lead from lead-based paints.**
- Crystalline silica from bricks, cement and other masonry products.**
- Arsenic and chromium from chemically-treated lumber.**

Your risk from these exposures varies, depending on how often you do this type of work. To reduce your exposure to these chemicals: Work in a well ventilated area, and work with approved safety equipment, such as those dust masks that are specially designed to filter out microscopic particles.

Table Of Contents

	PAGE
1. SAFETY	3
SAFETY SYMBOLS	3
SAFETY INSTRUCTIONS FOR POWER TOOLS	3-4
ADDITIONAL SAFETY INSTRUCTIONS FOR PLANERS.....	5
2. CIRCUIT REQUIREMENTS	6
220V OPERATION	6
FUSING	6
GROUNDING	6
EXTENSION CORDS	6
3. INTRODUCTION	7
COMMENTARY	7
UNPACKING.....	8
PIECE INVENTORY	8
CLEAN UP	9
SITE CONSIDERATIONS	9
4. ASSEMBLY	10
OVERVIEW.....	10
OPTIONAL STAND	10
PLANER UNIT	11
STARTER SWITCH	11
HANDWHEEL	12
KNIFE SETTING JIG	12
EXTENSION ROLLERS	13
DUST PORT	13
5. ADJUSTMENTS	14
OVERVIEW.....	14
GAUGE BLOCK	15
TABLE ADJUSTMENT	15-16
KNIFE INSPECTION	16-17
KNIFE ADJUSTMENT	17-18
CHIP BREAKER	18-19
FEED ROLLER HEIGHT	19-20
FEED ROLLER PRESSURE.....	20-21
BED ROLLERS	21-22
CHIP DEFLECTOR	22
ANTI-KICKBACK	23
BELTS	23-24
GEARBOX	24-25
THICKNESS SCALE	26

Table Of Contents

	PAGE
6. OPERATIONS	27
OVERVIEW.....	27
TABLE LOCKS	27
POWER FEED	28
HANDWHEEL.....	28
DEPTH LIMITER	28
TEST RUN	29
WOOD SPECIES	29
PLANING DIFFICULTIES.....	30
7. MAINTENANCE	31
GENERAL.....	31
TABLE.....	31
KNIVES.....	31
LUBRICATION.....	32-33
8. CLOSURE	34
MACHINE DATA.....	35
TROUBLESHOOTING	36
PARTS BREAKDOWN AND PARTS LISTS	37-42
ADJUSTMENT BLOCK PATTERN.....	43
WARRANTY AND RETURNS	44

SECTION 1: SAFETY

WARNING

For Your Own Safety Read Instruction Manual Before Operating This Equipment

The purpose of safety symbols is to attract your attention to possible dangers. This manual uses a series of symbols which are intended to convey the level of criticality of the safety message. The progression of symbols is described below. Remember that safety messages by themselves do not eliminate danger and are not a substitute for proper accident prevention measures.

 **NOTE** This symbol is used to alert the user to useful information about safe and proper operation of the equipment.

 **CAUTION** Failure to obey a CAUTION symbol and notation may result in minor or moderate property damage or personal injury.

 **WARNING** Failure to obey a WARNING symbol and notation can result in serious injury to yourself and others.

 **DANGER** Failure to obey a DANGER symbol and notation WILL result in serious personal injury including loss of life or body parts.

WARNING

Safety Instructions For Power Tools

- KEEP GUARDS IN PLACE** and in working order.
- REMOVE ADJUSTING KEYS AND WRENCHES.** Form habit of checking to see that keys and adjusting wrenches are removed from tool before turning on.
- KEEP WORK AREA CLEAN.** Cluttered areas and benches invite accidents.
- DON'T USE IN DANGEROUS ENVIRONMENT.** Don't use power tools in damp or wet locations, or where any flammable or noxious fumes may exist. Keep work area well lighted.
- KEEP CHILDREN AND VISITORS AWAY.** All children and visitors should be kept a safe distance from work area.
- MAKE WORK SHOP CHILD PROOF** with padlocks, master switches, or by removing starter keys.
- DON'T FORCE TOOL.** It will do the job better and safer at the rate for which it was designed.
- USE RIGHT TOOL.** Don't force tool or attachment to do a job for which it was not designed.

WARNING

Safety Instructions For Power Tools

9. **USE PROPER EXTENSION CORD.** Make sure your extension cord is in good condition. When using an extension cord, be sure it is rated Hard Service (grade S) or better. Conductor size must be 16 A.W.G. for cords up to 100 feet in length. An undersized cord will cause a drop in line voltage resulting in loss of power and overheating. Your extension cord must also contain a ground wire and plug pin. Always repair or replace extension cords if they become damaged. Minimum Gage for extension cord:

12 A.W.G.	50ft
10 A.W.G.	100ft
10. **WEAR PROPER APPAREL.** Do not wear loose clothing, gloves, neckties, rings, bracelets, or other jewelry which may get caught in moving parts. Non-slip footwear is recommended. Wear protective hair covering to contain long hair.
11. **ALWAYS USE SAFETY GLASSES.** Also use face or dust mask if cutting operation is dusty. Everyday eyeglasses only have impact resistant lenses, they are NOT safety glasses.
12. **SECURE WORK.** Use clamps or a vise to hold work when practical. It's safer than using your hand and frees both hands to operate tool.
13. **DON'T OVERREACH.** Keep proper footing and balance at all times.
14. **MAINTAIN TOOLS WITH CARE.** Keep tools sharp and clean for best and safest performance. Follow instructions for lubricating and changing accessories.
15. **DISCONNECT TOOLS** before servicing and changing accessories, such as blades, bits, cutters, and the like.
16. **REDUCE THE RISK OF UNINTENTIONAL STARTING.** Make sure switch is in off position before plugging in.
17. **USE RECOMMENDED ACCESSORIES.** Consult the owner's manual for recommended accessories. The use of improper accessories may cause risk of injury.
18. **CHECK DAMAGED PARTS.** Before further use of the tool, a guard or other part that is damaged should be carefully checked to determine that it will operate properly and perform its intended function. Check for alignment of moving parts, binding of moving parts, breakage of parts, mounting, and any other conditions that may affect its operation. A guard or other part that is damaged should be properly repaired or replaced.
19. **DIRECTION OF FEED.** Feed work into a blade or cutter against the direction of rotation of the blade or cutter only.
20. **NEVER LEAVE TOOL RUNNING UNATTENDED. TURN POWER OFF.** Don't leave tool until it comes to a complete stop.

WARNING

Additional Safety Instructions For Planers

1. Ensure that the machine sits firmly on the floor before use. Any “wobbles” must be corrected by shimming or blocking before operation.
2. This machine is not designed to process any other material except wood.
3. Never position fingers or thumbs near the infeed roller.
4. Long stock should always be fully supported by some type of support fixture.
5. Do not operate planer with dull or damaged knives.
6. Ensure that the planer is properly adjusted before using.
7. Do not remove excessive amounts of wood in a single pass.
8. Inspect your stock before planing. Reject stock with defects and foreign material.
9. Do not attempt to remove jams until power is disconnected and all moving parts have come to a complete stop.
10. Provide adequate infeed and outfeed space for operating the planer.
11. Do not plane wood less than 12" long and ¼" thick.
12. Do not plane lumber with loose knots or knots that may become loose during planing.

WARNING

Like all power tools, there is danger associated with the Model G1021 15" Planer. Use the tool with respect and caution to lessen the possibility of mechanical damage or operator injury. If normal safety precautions are overlooked or ignored. Serious personal injury may occur.

CAUTION

No list of safety guidelines can be complete. Every shop environment is different. Always consider safety first, as it applies to your individual working conditions. Use this and other machinery with caution and respect. Failure to do so could result in serious person injury, damage to equipment or poor work results.

WARNING

Always wear ANSI-approved safety glasses or goggles and hearing protection when operating equipment. Do not allow visitors into your workshop when testing or operating equipment unless similarly equipped. Serious personal injury may occur.

SECTION 2: CIRCUIT REQUIREMENTS

220V Operation

The G1021 Planer motor is wired to operate at 220V only. A cordset without a 220V plug is included with the Model G1021. Plugs and receptacles can be purchased at your local hardware store or home center. When connecting to 220V, ensure that the electrical circuit is in fact a 220V circuit. Contact your local electrical contractor if uncertain about converting to 220V operation.

When operating at 220V, we recommend using a NEMA-style 6-15 plug and outlet as depicted in **Figure 1**. You may also “hard-wire” the planer directly to your panel, provided you place a disconnect switch near the machine. Check the electrical codes in your area for specifics on wiring requirements.

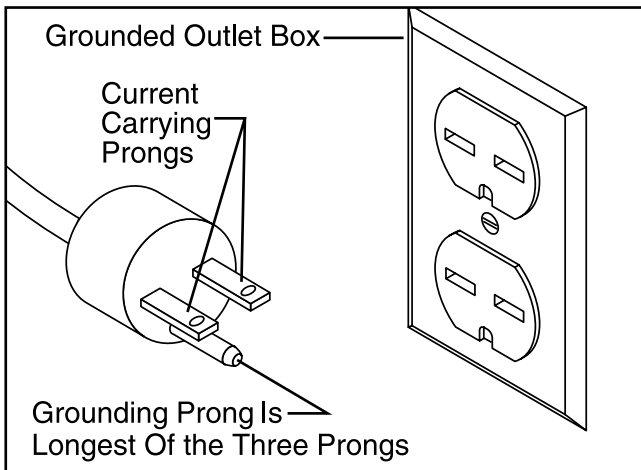

Figure 1. NEMA 6-15 220V/15A connector.

Fusing

Under normal load, the Model G1021 draws about 12 amps. We recommend a 15-amp circuit or a 20-amp slow-blow fuse. A circuit rated any higher will not adequately protect the motor.

Equipment returned to us for service that shows evidence of being over-fused will be repaired or replaced totally at the customer's expense, regardless of the present warranty status.

Grounding

In the event of an electrical short, grounding reduces the risk of electric shock by providing a path of least resistance to disperse electric current. This tool is equipped with a power cord having an equipment-grounding conductor. The outlet must be properly installed and grounded in accordance with all local codes and ordinances.

WARNING

This equipment must be grounded. Please ensure that this machine is continuously grounded from the motor to the machine frame and then to a known ground. Verify that any existing electrical outlet and circuit you intend to plug into is actually grounded. If it is not, it will be necessary to run a separate 12 A.W.G. copper grounding wire from the outlet to a known ground. Under no circumstances should the grounding pin from any three-pronged plug be removed. **Serious injury may occur.**



Extension Cords

If used, extension cords must be rated hard service – grade S – or better. Conductor size must be 12 AWG for cords up to 50 feet in length. Your extension cord must also contain a ground wire and plug pin. To ensure safe and dependable machine performance, inspect cords frequently for wear or damage. Replace or repair the cord immediately if evidence of damage is apparent.



SECTION 3: INTRODUCTION

Commentary

Grizzly Industrial, Inc. is proud to offer the Model G1021 15" Planer. The G1021 is part of Grizzly's growing family of fine woodworking and metal-working machinery. When used according to the guidelines stated in this manual, you can expect years of trouble-free, enjoyable operation.

The Model G1021 is intended for home and professional use. The G1021 features a 2 HP, 220V single-phase motor with magnetic power switch, precision ground cast iron table, bed rollers, extension rollers and dual feed capability for maximum versatility.

Optional accessories are available through Grizzly Industrial and include a stand, mobile base, knife setting jigs and replacement knives.

We are also pleased to provide this manual with the Model G1021. It was written to guide you through assembly, review safety considerations, and cover general operating procedures. It represents our effort to produce the best documentation possible. If you have any comments regarding this manual, please write to us at the address below:

Grizzly Industrial, Inc.
c/o Technical Documentation
P.O. Box 2069
Bellingham, WA 98227-2069

Above all else, we stand behind our machines. We have an excellent service department at your disposal should the need arise. If you have any service questions or parts requests, please call or write to us at the location listed below.

Grizzly Industrial, Inc.
1203 Lycoming Mall Circle
Muncy, PA 17756
Phone: (570) 546-9663
Fax: (800) 438-5901
E-Mail: techsupport@grizzly.com
Web Site: <http://www.grizzly.com>

G1021 15" Planer

To operate this, or any power tool, safely and efficiently, it is essential to become as familiar with its characteristics as possible. Take as much time as necessary to become acquainted with the Model G1021. The time you invest before you begin to use your machine will be time well spent. Also, read all of the safety procedures. If you do not understand something, **DO NOT** operate the machine.

The specifications, drawings, and photographs illustrated in this manual represent the Model G1021 as supplied when the manual was prepared. However, owing to Grizzly's policy of continuous improvement, changes may be made at any time with no obligation on the part of Grizzly. Whenever possible, though, we send manual updates to all owners of a particular tool or machine. Should you receive one, we urge you to insert the new information with the old and keep it for reference.

NOTE

The information in this manual has been obtained from sources we believe to be reliable and as up-to-date as possible. We have included some important safety measures we believe to be essential for safe operation. While most safety measures are generally universal, Grizzly reminds you that each workshop is different and safety rules should be considered as they apply to your specific situation.



Unpacking

The bandsaw is shipped from the factory in a carefully packed carton. If you find the machine to be damaged after you've signed for delivery and the truck and driver are already gone, you will need to file a freight claim with the carrier. Save the containers and all packing materials for inspection by the carrier or their agent. Without the packing materials, filing a freight claim can be difficult. If you need advice regarding this situation, please call us immediately.

WARNING

The G1021 is a heavy machine with a 475 lb. shipping weight. DO NOT over-exert yourself while unpacking or moving your machine – get assistance. In the event that your planer must be moved up or down a flight of stairs, be sure that the stairs are capable of supporting the combined weight of people and the machine. Failure to use care while assembling or moving could result in serious personal injury.



Parts Inventory

Take a quick inventory of the parts and put them aside for assembly later. After all the parts have been removed from the container, you should have:

- Planer Unit
- Dust Port
- Roller Extensions
- Hand Wheel
- Stand Top (Optional)
- Stand Legs (Optional)
- Stand Braces (Optional)

Now is a good time to inventory the fasteners required for assembly:

Hardware	Qty
Cap Screw 6mm - 1.0 x 12	3
Lock Washer 6mm	3
Hex Bolts 6mm - 1.0 x 12	3
Hex Nuts 6mm - 1.0	3
Washers 6mm	6
Knife Setting Jig Rod	1
Knife Setting Jig Brackets	2
E-clips	2
Allen® Wrench 3mm	1
Allen® Wrench 4mm	1
Allen® Wrench 5mm	1
Allen® Wrench 6mm	1
Open End Wrench 8-10mm	1
Open End Wrench 12-14mm	1
Handle	1
Hex Nut 10mm - 1.25	1
Flat Washer 10mm	1
Scale	1
Hex Bolts 8mm -1.25 x 20	6
Flat Washers 8mm	6
Setscrews 8mm - 1.25 x 12	6

Stand Hardware (Optional)	Qty
Carriage Bolts $\frac{5}{16}$ " - 18 x $\frac{5}{8}$ "	24
Hex Nuts $\frac{5}{16}$ " - 18	28
Flat Washers $\frac{5}{16}$ "	24
Hex Bolts $\frac{5}{16}$ " - 18 x 2"	4
Fender Washers	8

In the event that any parts are missing, we will be happy to replace them. Contact our Customer Service number for assistance. If any non-proprietary parts such as nuts, bolts or washers are missing, we will be happy to replace these too, but for the sake of expediency, these items can be obtained at your local hardware store.

CAUTION

Some die-cut metal parts may have sharp edges (called "flashing") on them after they are formed. Please examine the edges of all die-cut metal parts before handling them. Failure to do so could result in injury.



Clean Up

The unpainted surfaces are coated with a waxy oil to protect it from corrosion during shipment. Remove the protective coating with common paint thinner (mineral spirits) and paper towels. Do not use gasoline or other petroleum based solvents because of their extremely low flash points. Do not use chlorine-based solvents – if you happen to splash some onto a painted surface, you'll ruin the finish.

WARNING

Follow the safety rules listed below when working with solvents.

1. Read and follow all directions and warnings on the solvent label.
2. Work only in a well ventilated area.
3. Do not work near any type of open flame (e.g., pilot lights, kerosene heaters, and so on).
4. **DO NOT** smoke while working with flammable material.
5. Paper towels from the cleaning process are extremely combustible. Dispose of waste towels so they do not create a fire hazard.

CAUTION

Many of the solvents commonly used to clean machinery can be highly flammable, and toxic when inhaled or ingested. Always work in well-ventilated areas far from potential ignition sources when dealing with solvents. Use care when disposing of waste rags and towels to be sure they do not create fire or environmental hazards. Keep children and animals safely away when cleaning and assembling this machine.

Site Considerations

FLOOR LOAD

Your G1021 Planer represents a relatively large weight load in a small footprint. Most commercial floors are suitable for the Model G1021. Some residential floors may require additional support to accommodate both machine and operator.

WORKING CLEARANCES

Working clearances can be thought of as the distances between machines and obstacles that allow safe operation of every machine without limitation. Consider existing and anticipated machine needs, size of material to be processed through each machine, and space for auxiliary stands and/or work tables. Also consider the relative position of each machine to one another for efficient material handling. Be sure to allow yourself sufficient room to safely run your machines in any foreseeable operation.

LIGHTING AND OUTLETS

Lighting should be bright enough to eliminate shadow and prevent eye strain. Electrical circuits should be dedicated or large enough to handle combined motor amp loads. Outlets should be located near each machine so power or extension cords are not obstructing high-traffic areas. Be sure to observe local electrical codes for proper installation of new lighting, outlets, or circuits.

CAUTION

Make your shop “child safe”. Ensure that your workplace is inaccessible to youngsters by closing and locking all entrances when you are away. Never allow visitors in your shop when assembling, adjusting or operating equipment.



SECTION 4: ASSEMBLY

Overview

Most of your G1021 Planer has been assembled at the factory, but some parts must be assembled or installed after delivery. We have organized the assembly process into steps. Please follow along in the order presented here.

TOOLS REQUIRED: Most of the tools required for assembly are included with the planer. However, you will also need a Phillips® and regular screwdriver as well as feeler gauge for adjustments later on.



Optional Stand

To begin stand assembly, keep all the stand parts within easy reach. To ease assembly, build the stand upside down on a bench and then place it upright on the floor.

1. Place the stand top upside down on your bench.
2. Attach each of the four legs to the stand top with carriage bolts, washers and nuts provided. Do not over tighten. The legs attach to the outside of the stand top. See **Figure 3**.
3. Attach each of the four braces to the stand legs with carriage bolts, washers and nuts provided. Do not over tighten. The braces attach to the inside of the legs. See **Figure 2**.
4. Flip the stand right side up and place on the floor. Check to see if the stand is symmetrical from two adjacent sides. Adjust if necessary and securely tighten all nuts.



Figure 2. Stand crossbracing in place.



Figure 3. Fully assembled stand.



Planer Unit

TO MOUNT THE PLANER:

1. Using the lifting handles shown in **Figure 4**, place the planer on the stand and align the four holes in the base over the four mounting holes in the stand.
2. Secure the planer base to the stand with the four hex bolts, nuts, washer and fender washers provided.

CAUTION

This planer is relatively heavy and awkward to handle. We strongly recommend that you get assistance. It will require at least two people to lift the planer onto the stand. Lifting without ample assistance could result in serious injury and/or damage to your machine. The planer unit may also be unstable until it is permanently mounted to the stand. Use care so the planer unit does not slide or tip. If placing the planer on a shop-built stand, ensure that the stand is stable and designed to carry the weight of the planer. Always bolt the planer to any stand including a shop-built stand.

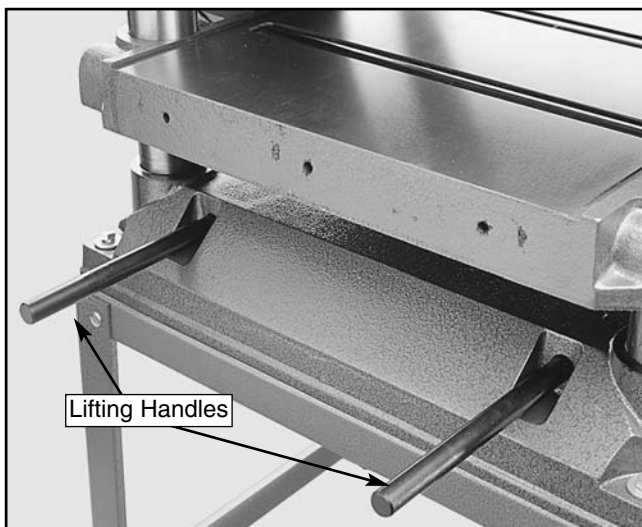

Figure 4. Location of lifting handles.



Starter Switch

The thermally protected, magnetic switch protects the motor from overload and the operator in case power is interrupted. If power is interrupted, the planer will not turn on when power resumes without first pressing the ON button.

The switch must be secured to the planer unit. The cap screws used for this purpose are already partially screwed in.

1. Unscrew the cap screws from the planer body for mounting the switch. See **Figure 5**.
2. Support the switch and screw the cap screws back in.

To connect the switch power leads to the motor:

1. Remove the motor junction box cover and slip the power cord through the cable clamp. Secure the cable clamp with a screwdriver.
2. Attach the two power leads to the motor terminals according to the wiring diagram supplied with this manual.
3. Attach the grounding terminal (green wire) to the motor frame via the ground screw located inside the junction box.
4. Re-attach the motor junction box cover.

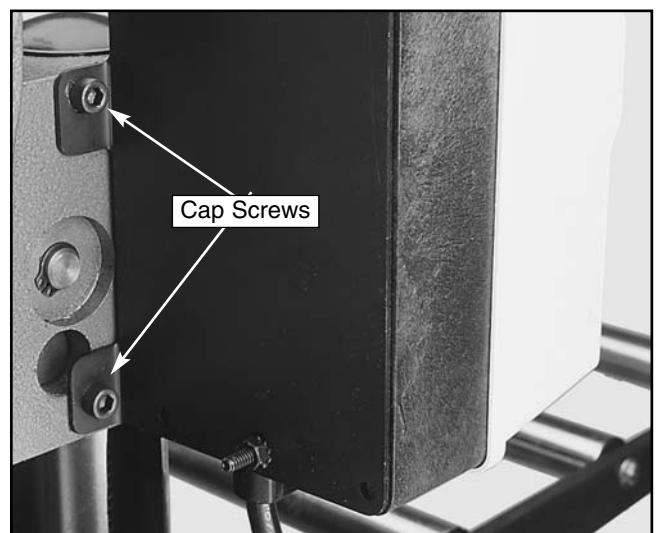

Figure 5. Starter switch attachment.

Handwheel

The handwheel is used to raise and lower the planer table. Each complete revolution raises the table $\frac{5}{32}$ " (4mm).

TO MOUNT THE HANDWHEEL:

1. Place the handwheel over the keyed shaft on the planer body. Make sure the key on the shaft and the keyway on the handwheel line up. The handwheel shaft is at the front right of the planer. See **Figure 6**.
2. Press the direction scale over the keyed shaft so it fits into the depression in the top of the handwheel.
3. Secure the handwheel with the 10mm - 1.25 hex nut and washer provided.

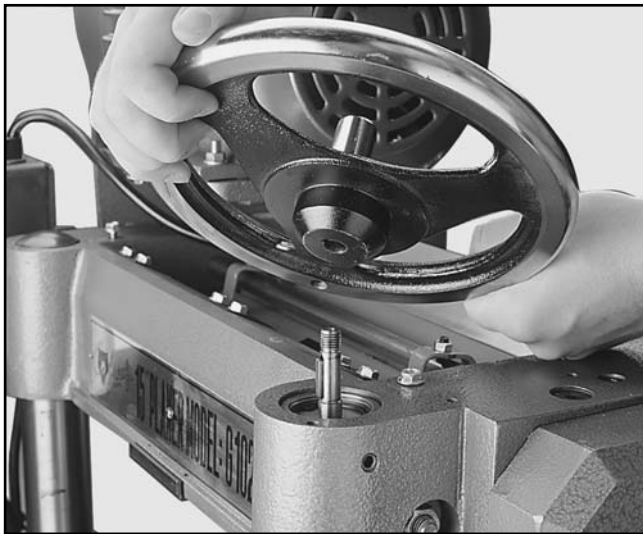

Figure 6. Handwheel attachment.



Knife Setting Jig

The knife setting jig has been provided to make knife setting quick and easy. See **Figure 7**.

TO ASSEMBLE THE KNIFE SETTING JIG:

1. Snap one of the E-clips over the notch on one end of the knife setting rod.
2. Slide the cast aluminum knife setting jig brackets onto the rod.
3. Snap the other E-clip onto the notch at the other end of the knife setting rod.

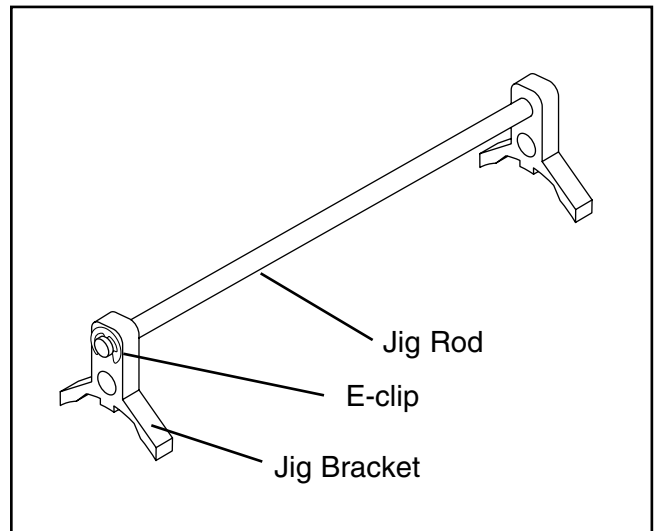

Figure 7. Knife setting jig components.

CAUTION

Planer knives are dangerously sharp. Use extreme caution when working near cutting surfaces. Failure to exercise care while working near knives could result in severe injury.



Extension Rollers

The extension rollers can be attached now, but it may be easier to make all the necessary adjustments to the planer before attaching them.

TO ATTACH THE EXTENSION ROLLERS:

1. Use the hex bolts and washers to mount the extension rollers. See **Figure 8**. Ensure that the top of the rollers are above the extension roller frame.
2. Finger-tighten the mounting bolts for now. Alignment of the extension rollers with the table surface will be covered in the Adjustment Section.

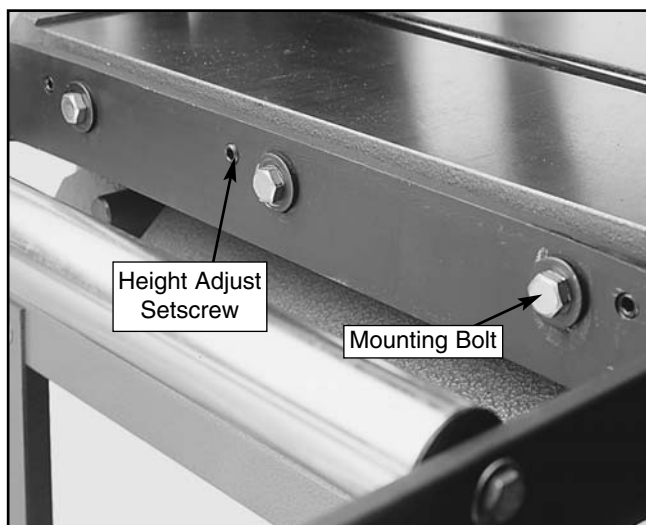

Figure 8. Extension roller attachment points.



Dust Port

The G1021 Planer features a 4" dust port for use with a dust collection system.

As with the extension rollers, you may find it more convenient to attach the dust port after making adjustments to the planer.

TO ATTACH THE DUST PORT:

1. Fit the dust port over the planer upper cover. Line up the mounting holes.
2. Use three M6 - 1.0 x 12mm hex bolts and nuts and six washers to secure the dust port to the planer upper cover. See **Figure 9**.
3. Use three M6 - 1.0 x 12mm cap screws and lock washers to secure the dust port to the planer body.

CAUTION

DO NOT attach the dust hood if you do not intend to connect the Model G1021 to a dust collection system. Accumulated wood chips could cause a malfunction, resulting in personal injury or damage to the planer.

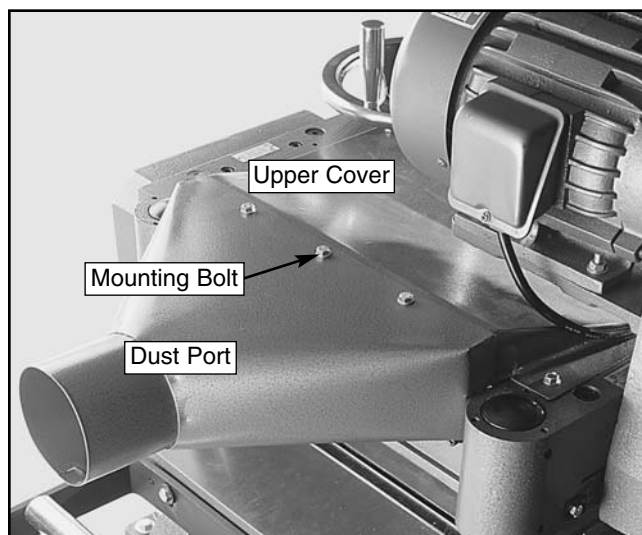

Figure 9. Dust port assembly.



SECTION 5: ADJUSTMENTS

Overview

Once assembly has been completed, your G1021 15" Planer requires just a few adjustments to ready it for use in your shop.

Many adjustments have already been made at the factory, yet we recommend you familiarize yourself with all of the following procedures to gain a better understanding of the Planer's construction and operation.

General control and adjustment locations are shown in **Figure 10**.

- A. The switch is thermally protected and magnetically controlled and features push buttons to turn the planer on and off.
- B. The handwheel raises and lowers the table and controls the depth of cut. Turning the handwheel clockwise raises the table and counter-clockwise lowers the table.
- C. The bed rollers ease stock movement through the planer and are adjustable.
- D. The three position feed rate change knob shifts planer feed speed from neutral to 16 and 20 feet per minute.
- E. The table lock knob secures the table in a fixed position.

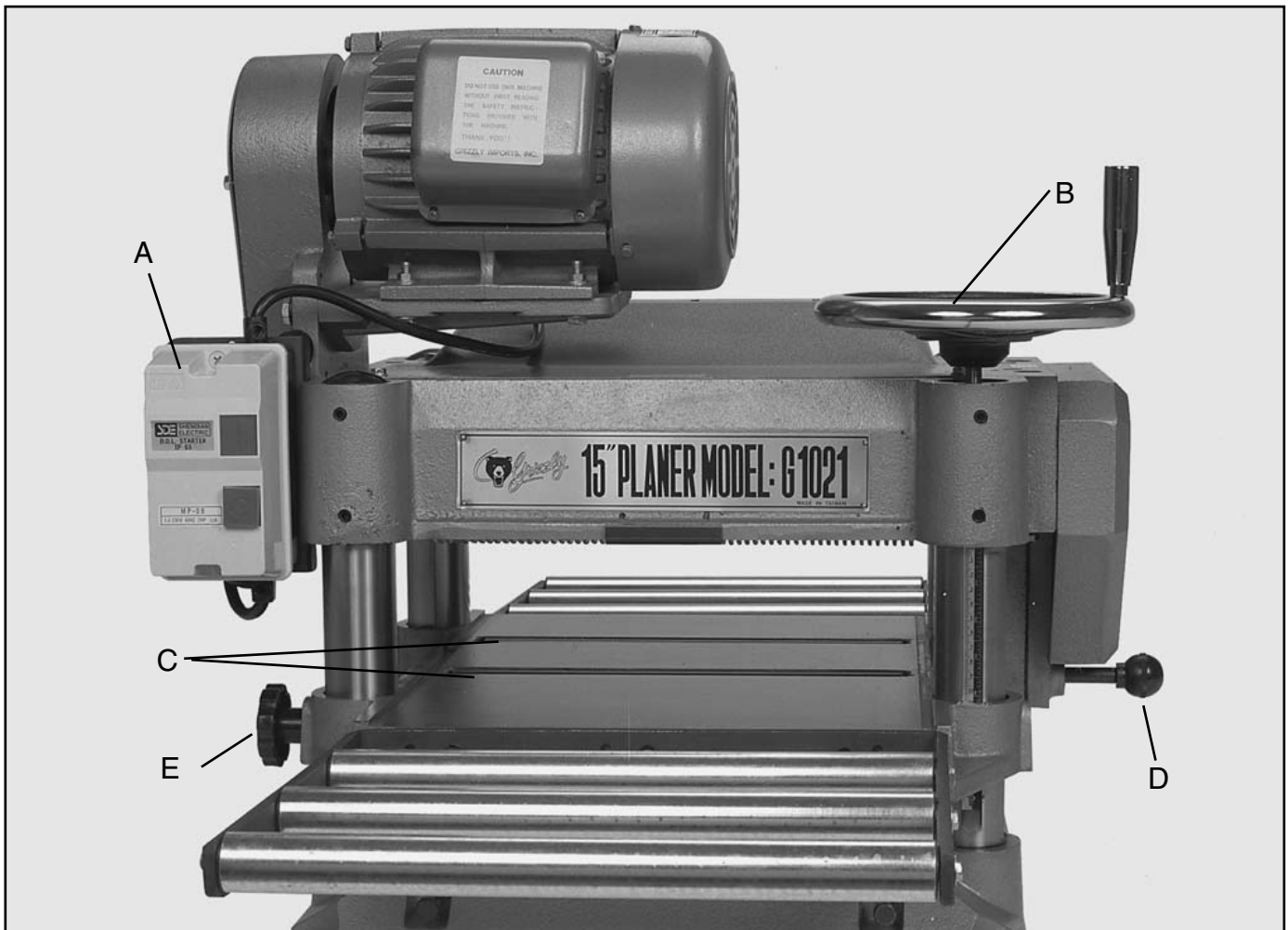

Figure 10. Overview of planer adjustment controls.

Gauge Block

Before attempting any table adjustments, you will need to construct a gauge block. See **Figure 11**. A larger gauge block diagram is also included at the end of the manual for your convenience. Precision adjustments later on require accuracy when milling the gauge block. **Do not** use common 2x4 material. Use maple or similar type of hardwood. **Do not** use the planer during the milling process since the gauge block is needed first to check and make planer adjustments.

Using a magnetic dial indicator is a good alternative to constructing a gauge block. Use the dial indicator whenever the instructions call for use of the gauge block and/or feeler gauge. Refer to the current Grizzly catalog for dial indicators.

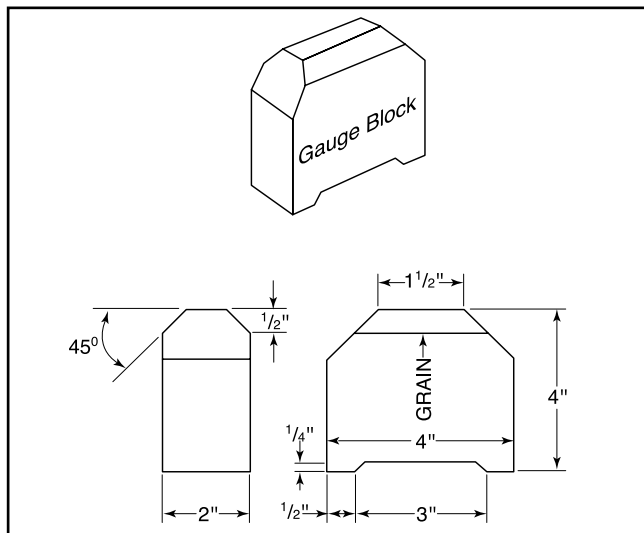

Figure 11. Guide block specifications.

WARNING

DO NOT make adjustments while the planer is running. Ensure that the switch is off, power is disconnected and moving parts have stopped before making adjustments. Failure to comply could result in serious injury or electrical shock hazard.



Table Adjustment

To plane stock perfectly square, it is important that the table is parallel to the cutterhead.

TO CHECK TABLE PARALLELISM:

1. Place the gauge block on the table under one end of the cutterhead.
2. Turn the handwheel to raise the table until the block barely touches the cutterhead body. The block should not be touching the knives. See **Figure 12**.
3. Slide the block toward the opposite side of the cutterhead. Use a feeler gauge to measure the width of the gap, if any, between the top of the block and the bottom of the cutterhead. If there is a gap, make a note, reading the distance from the feeler gauge.
4. If the block wedges tightly between the table and cutterhead when shifting from one side to the other, repeat steps 1 through 3 above, but start from the opposite end of the cutterhead.



Figure 12. Guide block indicates parallelism.

If the gap difference from one side to the other is equal to or less than 0.004", no further adjustment is necessary.

If the gap difference from one side to the other is greater than 0.004", but less than 0.016", go to step 5.

If the gap difference from one side to the other is greater than 0.016", the table raising chain under the planer base will need to be adjusted. Please call our Customer Service number for chain adjustment instructions.

To adjust for gap differences of less than 0.016":

1. Determine which side of the table must be raised to correct the gap.
2. Locate the two cap screws in the table casting for each of the columns. See **Figure 13**. Loosen both sets of cap screws for each column on the side you wish to adjust.
3. Push down or pull up the table in the desired direction. Hold the table in position and retighten the cap screws.
4. Recheck the table to cutterhead parallelism again. Repeat steps 1 through 7 until the deviation is less than 0.004".

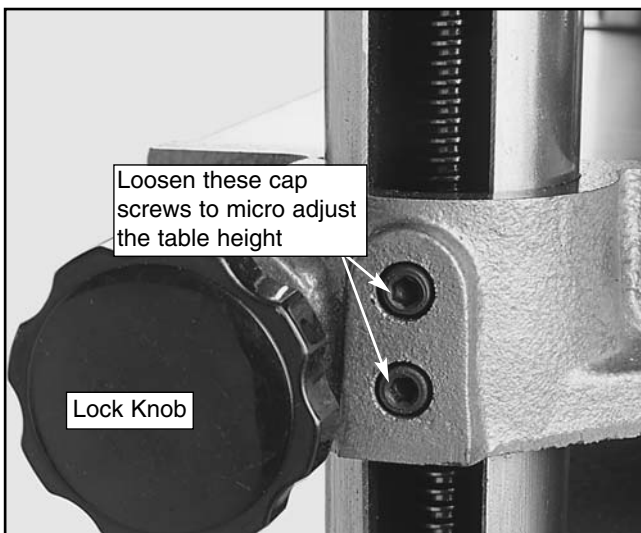

Figure 13 Cap screws for column adjustment.



Knife Inspection

The Model G1021 Planer has a three-knife cutterhead. The cutterhead is located in the head casting and rotates on two sealed bearings. No lubrication is needed for the life of the bearings.

Because of normal use and wear, the knives must be periodically sharpened, replaced or adjusted. Adjustment from the factory must also be checked prior to use due to possible movement during shipment.

TO INSPECT THE KNIVES:

1. Lower the table and place the gauge block under one end of the cutterhead.
2. Carefully turn the cutterhead until the first knife is at bottom dead center. Raise the table until the knife barely touches the top of the gauge block. Rock the cutterhead over the gauge block as you raise or lower the table to determine bottom dead center.
3. Slide the gauge block to the opposite side of the cutterhead and check the same knife, rocking back and forth to determine bottom dead center. If the knife does not contact the gauge block, use a feeler gauge to determine the difference between one side and the other. **See Figure 14**. Again, rock the cutterhead back and forth over the gauge block and feeler gauge.

WARNING

Planer knives are dangerously sharp. Use extreme caution when inspecting, removing, sharpening, or replacing knives into the cutterhead. Substantial risk of injury!

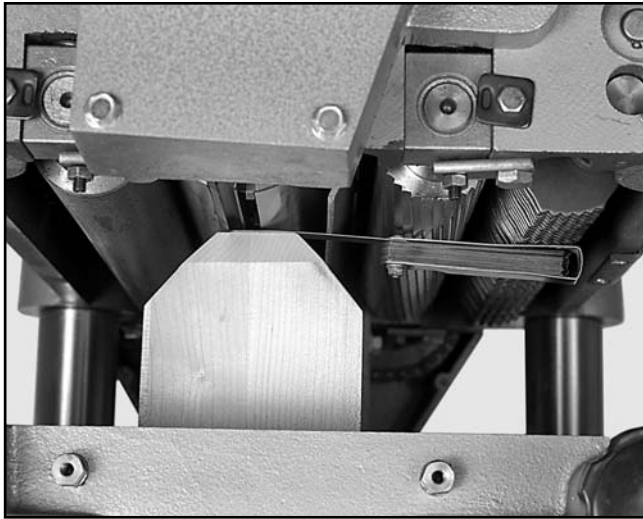

Figure 14. Adjusting knife height.

4. If the knife bottoms out on the gauge block, repeat steps 1, 2 and 3, but start on the opposite side of the cutterhead.
5. The variation between one side and the other should not be greater than 0.004". Repeat steps 1 through 4 on the other two knives. Again, the variation between all three knives should not be greater than 0.004"

Once you have completed inspection on all three knives, you will be able to determine whether or not there is a need to adjust the knives in the cutterhead. The next set of instructions will address the process of setting the knives.

CAUTION

When making adjustments, all three knives must be adjusted the same. Do not adjust one knife without adjusting the others as well. Improper knife height adjustment can result in damage to knives, poor planer performance and possible operator injury.



Knife Setting

The process of setting the knives in the cutterhead will come into play whenever you sharpen or replace, or after determining that setting is necessary during the initial setup.

The knives are locked into the cutterhead with wedge type gibs. Springs under each knife provide an upward pressure to help ease the setting process.

TO SET THE KNIVES:

1. Remove the upper cover to expose the cutterhead.
2. Loosen the gib bolts securing the first knife just enough until the knife pushes upward.
3. Place the knife setting jig over the knife on the cutterhead as shown in **Figure 15**. The knife setting jig will push the knife into position in the cutterhead.

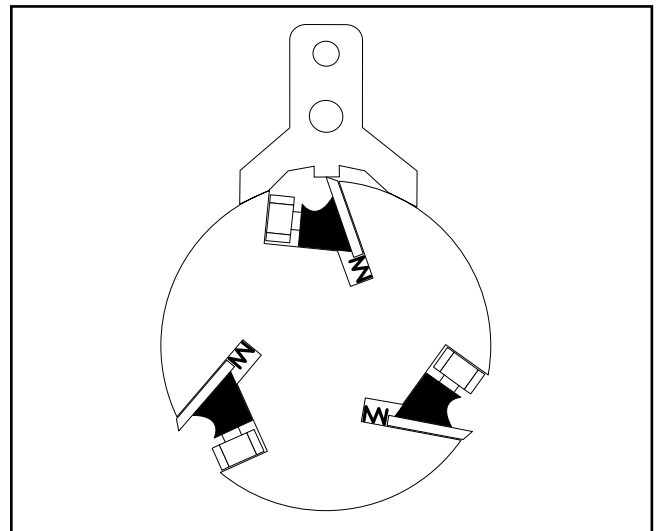

Figure 15. Proper knife setting jig placement.

4. While holding the position of the knife setting jig, tighten the gib bolts down again in the cutterhead. Tighten the bolts evenly from the outside, working toward the middle. See **Figure 16**.
5. Repeat these steps for the other two knives.



Figure 16. Tightening knives in cutterhead.



Chip Breaker

The chip breaker is located on the top side of the planer and extends down around the front of the cutterhead. Its function is to prevent tear-out or deep, unregulated gouging as the knives remove material. The chip breaker works by breaking the woodchips as they are being cut by the cutterhead. The chip breaker also deflects and expels the woodchips away from the surface of the board and out of the planer.

TO ADJUST THE CHIPBREAKER:

1. Disconnect the machine from the power source, remove the dust hood and lower the table.
2. Ensure that the knives are properly adjusted.

3. Place the gauge block on the table directly under the cutterhead. Using a one millimeter (0.05") feeler gauge between the gauge block and the cutterhead, raise the table until one of the knives just touches the feeler gauge. Rotate the cutterhead manually to be sure the knife is at bottom dead center.
4. Lock the table by tightening the table lock knobs.
5. Remove the feeler gauge and slide the gauge block under the chip breaker. See **Figure 17**. The chip breaker should just touch the top of the gauge block. Slide the gauge block to the opposite end of the chip breaker and check it in the same manner.

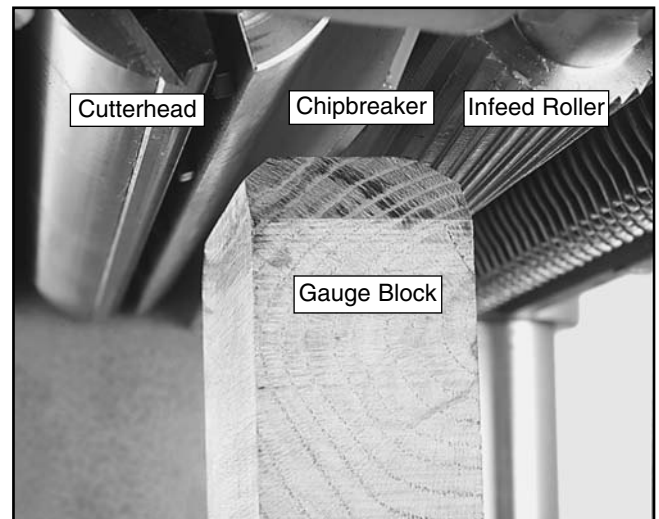

Figure 17. Location of chip breaker assembly.

WARNING

DO NOT make adjustments while the planer is running. Ensure that the switch is off, power is disconnected and moving parts have stopped before making adjustments. Failure to ensure that power is disconnected could result in serious injury or electrical shock hazard.

6. If an adjustment is necessary, loosen the locknuts and turn the setscrews. See **Figure 18**. Stop turning when the bottom of the chip breaker just touches the gauge block.
7. Re-tighten both locknuts
8. Replace the exhaust hood.

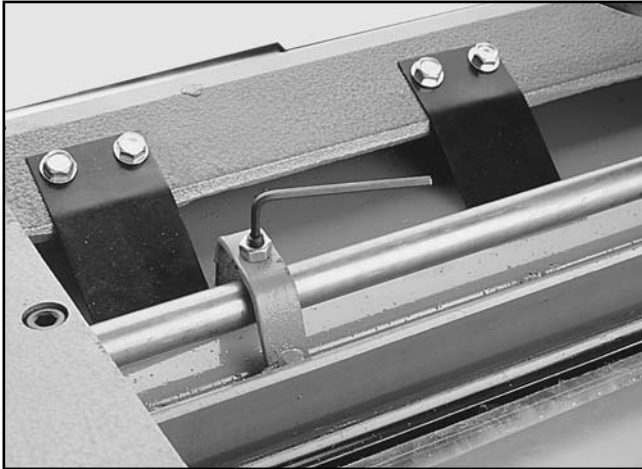

Figure 18. Chip breaker height adjustment.



Feed Roller Height

The infeed and outfeed rollers propel the lumber through the planer. The rollers also press the lumber flat against the planer table.

Set the infeed and outfeed rollers 0.040" below the knife edge at bottom dead center.

TO CHECK ROLLER HEIGHT:

1. Disconnect the machine from the power source.
2. Lower the table so the gauge block will fit under one side of the infeed roller.
3. Raise the table until the gauge block barely touches the infeed roller. See **Figure 19**. Do not change position of the table.
4. Slide the gauge block over so it is under the edge of one of the knives. Turn the cutterhead until one of the knives is at bottom dead center over the gauge block.
5. Measure the clearance between the top of the gauge block and the edge of the knife with a feeler gauge. Note the measurement indicated on the feeler gauge.

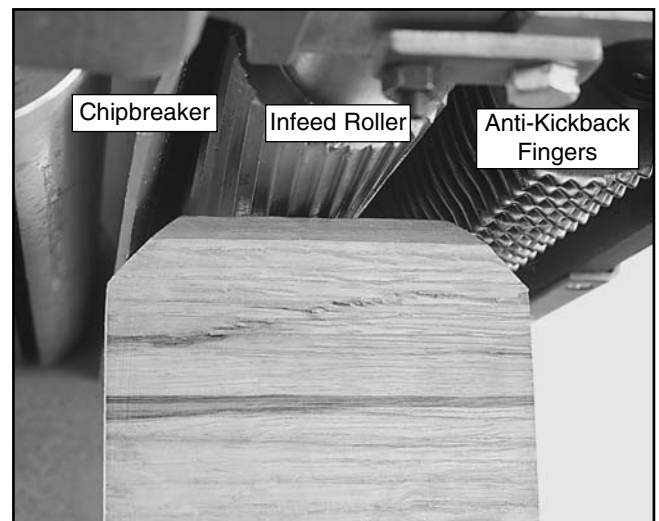

Figure 19. Feed roller height inspection.

- Repeat steps 1-5 for the opposite side of the roller. Repeat all steps for the outfeed roller.

Feeler gauge measurement should equal 0.040".

TO ADJUST ROLLER HEIGHT:

- Remove the drive chain cover to access the roller adjustments on the drive chain side of the planer. A single socket head cap screw holds the drive chain cover on. Belt side adjustments are already accessible.
- Loosen the roller adjustment check nuts and turn the roller height setscrews to change the height of the roller as needed. See **Figure 20**.
- Check roller height according to the above instructions. Continue turning the setscrew until the roller is properly adjusted.
- When the roller is set in the correct position, re-tighten the check nuts you loosened in Step 2 above.
- Check your settings one last time and repeat steps 1-4 if necessary.



Figure 20. Feed roller height adjustment.



Feed Roller Pressure

To be effective, the infeed and outfeed rollers must put pressure on the workpiece as it feeds through the planer. Too little pressure results in slipping boards, too much pressure results in jamming.

Experiment with the best pressure settings for your work situations. Some rough cut lumber will feed through fine with relatively few problems, while other lumber will have more difficulty.

Adjusting roller pressure does not affect height.

TO ADJUST ROLLER PRESSURE:

- Disconnect the machine from the power source.
- Ensure that knives and feed rollers are set correctly.
- Unscrew the four large pressure setscrews on top of the planer body. See **Figure 21**.

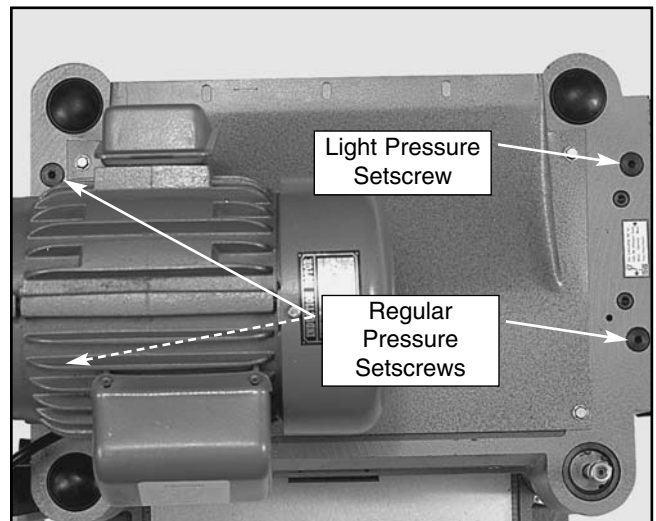

Figure 21. Roller pressure adjustment.

4. Remove the springs that are in the holes left by the setscrews. See **Figure 22**.
5. Check for any dirt or grit. Clean the springs and setscrews if dirty.
6. Screw the three regular-pressure setscrews back in until they are flush with the top of the head casting.
7. Screw the light pressure setscrew until it is approximately $\frac{1}{4}$ " above the head casting. The feed chain applies additional tension to the right side of the outfeed roller, so the pressure added by the setscrew need not be as high.

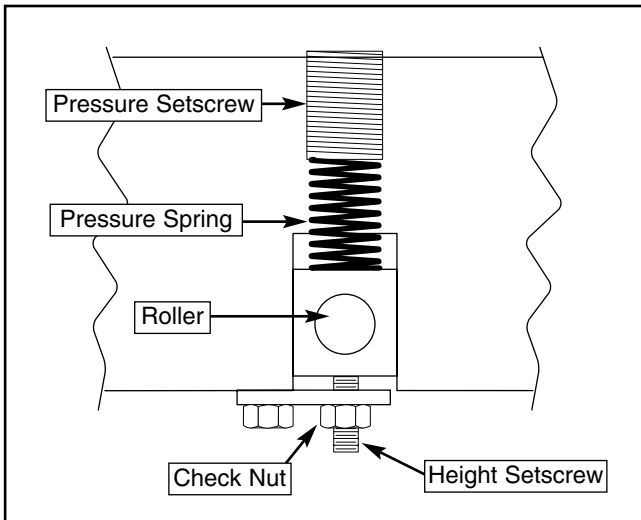

Figure 22. Roller pressure assembly.



Bed Rollers

The bed rollers ease stock movement through the planer. The height of the bed rollers will vary depending on the types of wood you will be planing. When planing rough stock, set the rollers slightly high to keep the lumber from dragging along the bed. However, snipe may be unavoidable. Smooth lumber should be planed with the rollers set just above the plane of the table. This will minimize snipe.

TO ADJUST THE BED ROLLERS:

1. Ensure that power is disconnected and lay a high quality straightedge across both table rollers. Use a try square to keep the straight-edge perpendicular to the table.
2. Use a feeler gauge to measure the clearance between the bottom of the straight edge and the table. Ideal clearance is between 0.002" and 0.005". Measure in several places. This measurement must be consistent across the entire table. See **Figure 23**.

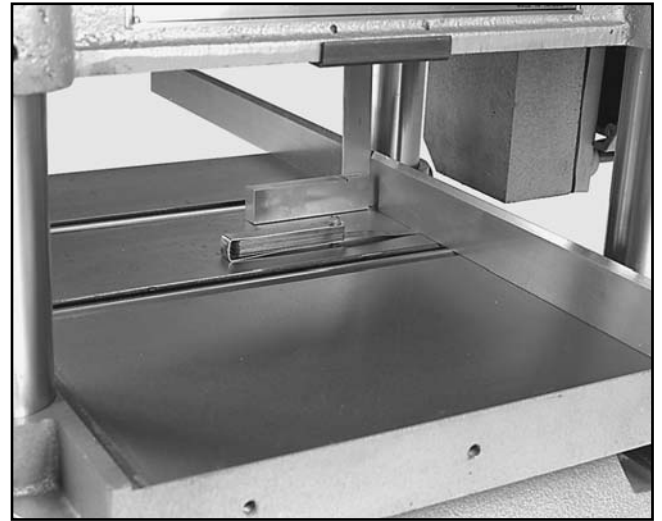

Figure 23. Inspecting bed roller height.

3. Loosen the setscrews on both sides of each bed roller. See **Figure 24**.
4. Use a wrench to turn the eccentric shafts which adjust roller height. Stop turning when the table rollers are at the proper height.
5. Once your roller heights are correct, re-tighten all the setscrews.
6. Check the height of the table rollers. Repeat steps 1-5 until the bed rollers are properly set. Spin the bed rollers to ensure free movement.

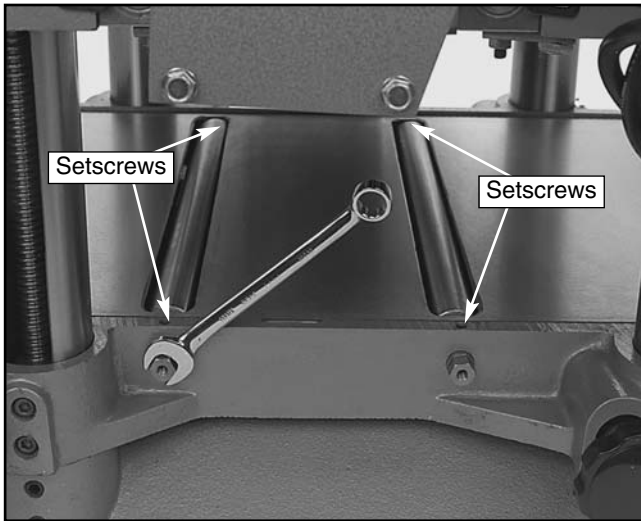

Figure 24. Adjusting bed roller height.



Chip Deflector

The chip deflector keeps chips from falling onto the outfeed roller. It is the orange plastic plate located under the top cover.

The beveled edge of the chip deflector should be about $\frac{1}{8}$ " - $\frac{1}{4}$ " from the knife edge. Carefully rotate the cutterhead to gauge the distance between the chip deflector and the knives. Adjust if necessary. However, if the chip deflector is set too close to the knives, the rotating cutterhead may pull it in and destroy it.

TO ADJUST THE CHIP DEFLECTOR:

1. Disconnect the machine from the power source and remove the planer's upper cover.
2. Loosen the three deflector mounting bolts. See **Figure 25**. Make sure the beveled edge of the deflector faces the cutterhead.

3. Move the deflector until its edge is approximately $\frac{1}{8}$ " - $\frac{1}{4}$ " from the tip of the cutting knives. Push down on the deflector with a wooden stick to check if it will touch the knives. Cautiously rotate the cutterhead to ensure clearance. **Do Not** touch the knives - severe cuts may result.
4. Re-tighten the chip deflector mounting bolts and re-mount the upper cover to the planer.

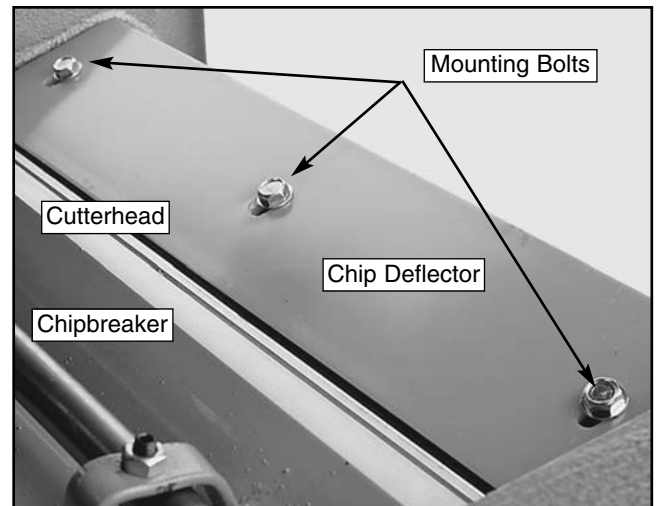

Figure 25. Chip deflector access.



Anti-Kickback

The Model G1021 Planer provides an anti-kickback safety feature. The anti-kickback fingers hang from a rod suspended across the front of the cutterhead casting. The anti-kickback fingers should be inspected regularly. Check the fingers to ensure that they swing freely and easily. See **Figure 26**.

WARNING

DO NOT apply oil or other lubricants to the anti-kickback fingers. Oil or grease will attract dust and restrict free movement of the fingers, which could result in damage to your workpiece, the planer, or possibly serious injury to the operator or others in the workplace. Call our Customer Service number if the anti-kickback fingers do not move freely when setting up your planer. **DO NOT** attempt to use the planer if the anti-kickback fingers are not operating properly.



Figure 26. Anti-kickback assembly.



Belts

The belt and pulley assembly are on the left side of the planer. The belts transfer power from the motor to the cutterhead and then through the gearbox to the feed rollers. Remove the belt cover by unscrewing the four flange bolts holding the cover in place.

TO INSPECT/ADJUST THE PULLEYS:

Place a metal ruler across the pulleys to check alignment. *The pulleys are aligned if the ruler crosses them evenly.* See **Figure 27**.

If the pulleys are out of alignment:

1. Loosen the bolts that hold the motor to the motor mount bracket.
2. Adjust the position of the motor until the pulleys are in line.
3. *Re-tighten all bolts.*

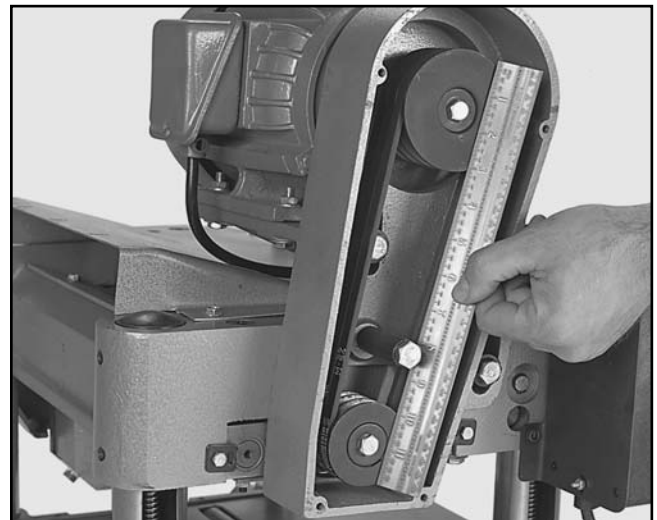

Figure 27. Checking pulley alignment.

TO CHECK BELT TENSION:

Squeeze the V-Belts at their midpoints with moderate finger pressure. *You should be able to deflect each V-Belt about 3/4". Belts will rarely be too tight, but will sometimes be too loose.*

To adjust belt tension:

1. Loosen the two bolts that hold the motor/pulley assembly to the planer.
2. Insert a wooden lever of suitable strength and pry the motor up to increase belt tension. See **Figure 28**.
3. Maintain lever position and check belt tension. Re-adjust if necessary.
4. Tighten the bolts and check belt tension again. Repeat steps 1-3 as necessary.
5. Ensure that the pulleys are still in alignment.

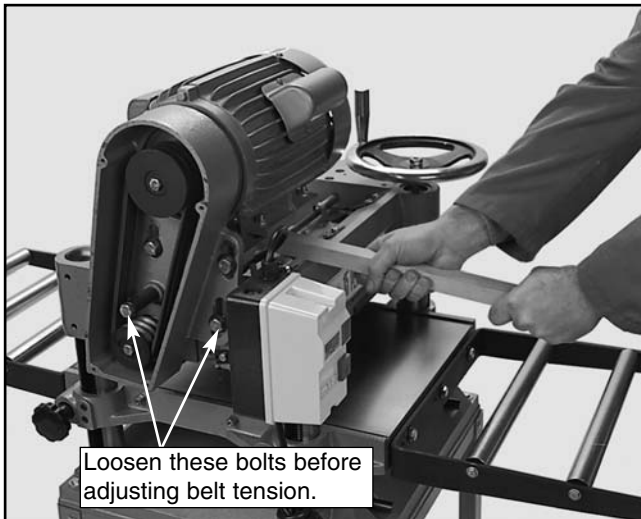

Figure 28. Adjusting belt tension.

WARNING

DO NOT make adjustments while the planer is running. Ensure that the switch is off, power is disconnected and moving parts have stopped before making adjustments. Failure to comply could result in serious injury.



Gearbox

The gearbox is located just behind the hand-wheel on the right side of the planer. The gearbox transfers power from the belt-driven cutterhead to the power feed rollers. The two-speed transmission is controlled by a push/pull lever on the right side of the planer. When engaged, the power feed rollers will move lumber through the planer at either 16 or 20 feet-per-minute. The center lever position is neutral.

TO INSPECT THE GEARBOX:

1. Loosen the socket head cap screw on the gearbox cover. Gently pull the cover off the roll pins that hold it in place.
2. Check the bolts holding the sprockets in place. Inspect the drive chains to ensure that the cotter pins are in place. Replace the pins if necessary. See **Figure 29**.

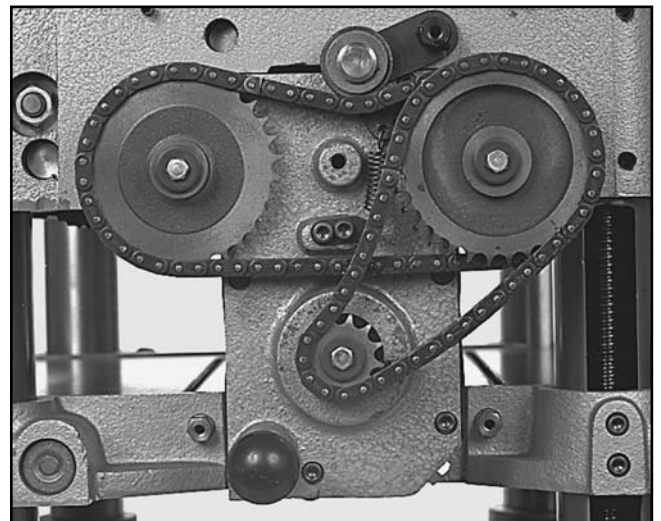

Figure 29. Location of sprocket bolts.

3. The oil level in the gearbox should be to the bottom of the filler plug near the top of the gearbox. Top off with 80-90 wt. gear oil if necessary. Use 50 wt. motor oil if you are working in an unheated winter shop. See **Figure 30**.
4. Drain and replace the oil yearly. See **Figure 31**.

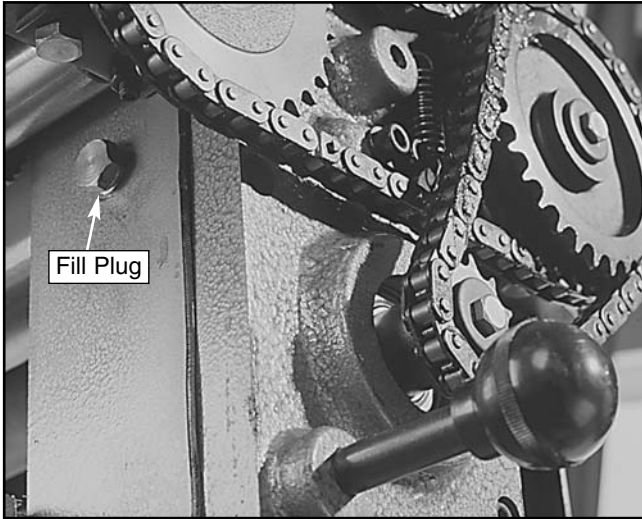

Figure 30. Location of gearbox fill plug.

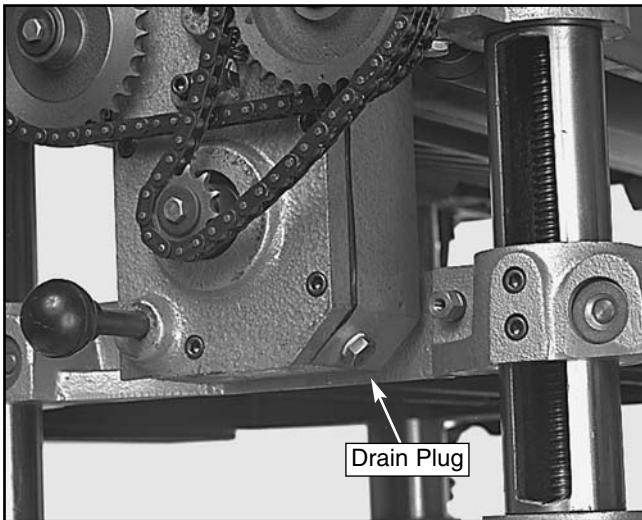

Figure 31. Location of gearbox drain plug.



Extension Rollers

N. EXTENSION ROLLERS

If you elected to wait to install the extension rollers during the assembly process, install the extension rollers now. Refer to the Assembly Section.

To adjust the extension rollers:

1. Lower the table and position a flat board, so it lays on the table and suspends over one of the extension rollers. See **Figure 32**.
2. Adjust the tightness of the mounting bolts and the depth of the setscrews on the extension roller body. Various combinations of loosening and/or tightening the setscrews and bolts will level the extension rollers with the table. When the outermost extension roller touches the bottom of the board, stop adjusting and secure the extension roller to the body.
3. Repeat steps 1-3 for the other extension roller assembly.

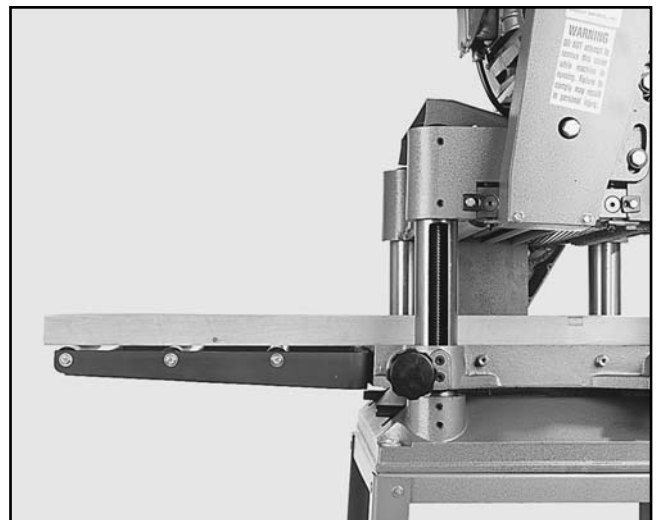

Figure 32. Inspecting extension roller height.



Thickness Scale

The thickness scale, located below the handwheel, can be adjusted for accuracy. **However, the machine must be operated to adjust the thickness scale. Follow the directions in the Operations Section for test running before attempting to make these adjustments.**

TO ADJUST THE SCALE:

1. Adjust the table height to the approximate thickness of your test lumber. Measure the lumber with calipers to determine its exact thickness.
2. Move the table to $\frac{1}{16}$ " under the thickness of your lumber and feed your test board through the planer.
3. Turn the handwheel one half rotation and run the board through once more. Turn the board over and repeat.

4. Re-measure the board and compare your results with the scale. If there is a discrepancy, loosen the scale adjustment screw and correct the position. See **Figure 33**.



Figure 33



NOTES

SECTION 6: Operations

WARNING

The Model G1021 15" Planer is a powerful woodworking machine, designed and constructed for professional-quality applications. Because of its powerful motor and razor-sharp knives, the Model G1021 is inherently dangerous and should be operated with considerable caution and respect. Failure to do so could result in damage to the machine, or severe injury to the operator or others in the work area.

Overview

In addition to the safety issues discussed earlier in this manual, there are a number of safety issues that relate directly to the operation of the planer. Keep in mind that these are not all-inclusive. Work situations, wood types, and other variables that differ from shop to shop must be considered in order to operate this planer safely. Always consider safety and common sense first when operating this or other machinery.

1. Always inspect lumber for defects (warping, cupping, twisting, etc.). Do not use lumber of questionable quality.
2. Check lumber for nails, staples, imbedded gravel, etc. before planing.
3. Use the full width of the planer. Alternate between the left, the right and the middle when feeding lumber into the planer. Your knives will remain sharp much longer.
4. Remove glues, epoxies and other foreign materials before planing lumber.
5. NEVER attempt to plane laminates, particle boards, plastics or other man-made materials.
6. Plane wood with the grain. NEVER plane end-grain lumber.

G1021 15" Planer

7. Do not use boards with loose knots, splits, crossgrain or other defects. They can damage the machine and cause injury.
8. Keep your work area clear.
9. Wood with more than 20% water content or wood exposed to rain, ice, or snow will plane poorly and cause excess wear to the knives and motor. Excessive moisture will also hasten rust and corrosion.
10. Read as much as possible about planing procedures. Alternative publications present more wood specific planing requirements. They will often share tips on safety and more efficient ways to operate your planer.



Table Locks

Before attempting to adjust table height, loosen the two black knobs on the left side of the table. After table height is adjusted and the table height is set, tighten the two black knobs back down again. See **Figure 34**.

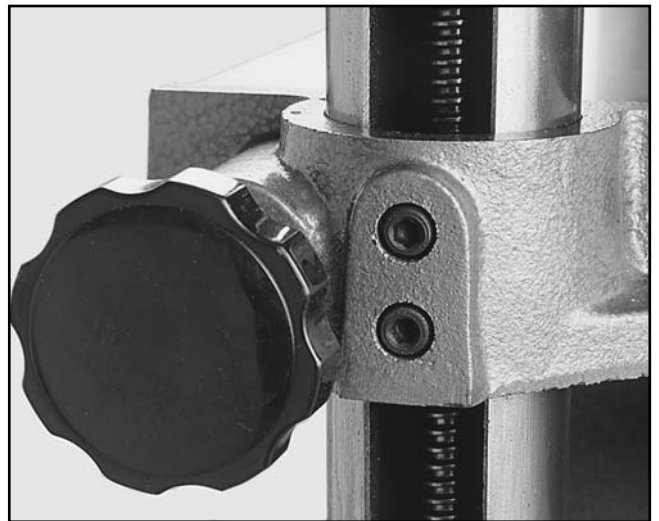

Figure 34. Table lock knob.



Power Feed

The power feed features two feed rates; 16 FPM and 20 FPM. When running the machine, the operator can control the feed speed by moving the feed control knob. Moving the knob toward the machine produces the 20 FPM feed speed, away from the machine produces 16 FPM and a center position places the gear box in neutral. **Figure 35.**

⚠ CAUTION

The feed rate should be set while the planer is running but before feeding lumber into it. **DO NOT** attempt to change speeds after the cutting operation has begun.

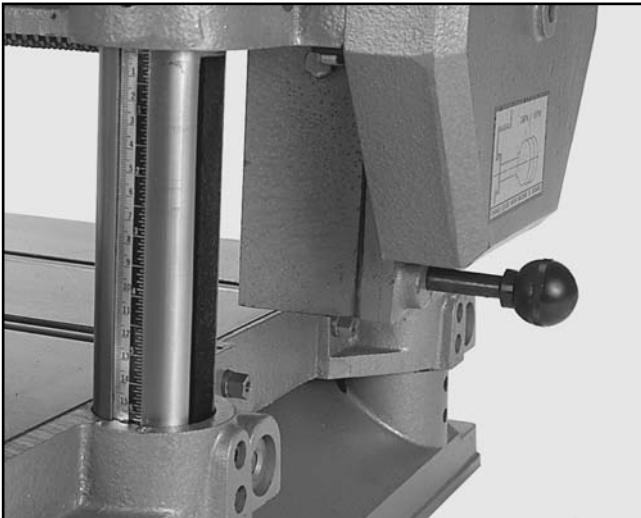

Figure 35. Feed speed adjustment knob.

⚠ CAUTION

If you take a cut that is too large, the planer will bog down noticeably. The motor may even stall. If this happens, turn off the power immediately, lower the table, and remove your workpiece. Re-adjust your table to allow a lesser cut and repeat your operation.



Handwheel

Crank the handwheel to raise or lower the table according to the desired workpiece thickness.

Each complete revolution of the handwheel moves the table by $\frac{5}{32}$ " (4mm). Make sure the height scale is properly adjusted.

With the limiting clip installed, you cannot cut more than $\frac{1}{8}$ " in a single pass. While cutting this much material is possible, it is not recommended. Take it slow and easy. The quality of your work will be better and your planer will last longer.



Depth Limiter

The Model G1021 is equipped with a depth limiter – located on the bottom of the cutterhead casting just under the nameplate. See **Figure 36.** The depth limiter controls maximum depth of cut to $\frac{1}{8}$ ".

⚠ CAUTION

To avoid mechanical damage to the planer, do not remove the depth limiter.



Figure 36. Location of depth limiter.

Test Run

Once the assembly is complete and the adjustments are done to your satisfaction, you are ready to test the machine.

Turn on the power supply at the main panel. Press the START button. Make sure that your finger is poised on the STOP button, just in case there is a problem. The planer should run smoothly, with little or no vibration or rubbing noises. Strange or unnatural noises should be investigated and corrected before operating the machine further.

 **WARNING**

DO NOT attempt to investigate or adjust the machine while it is running. Wait until the machine is turned off, unplugged and all working parts have come to a rest before you do anything!

If noises occur that cannot be found by visual inspection, feel free to contact our service department for help.

 **WARNING**

Always wear ANSI-approved safety glasses or goggles when operating equipment — particularly when testing new tools or machinery. Do not allow visitors into your workshop when testing or operating equipment.



Wood Species

The species of wood, as well as its condition, have a dramatic effect on planing ability. The harder the wood (as illustrated by its shear strength), the more difficult it will be to plane. A brief listing of common hard and soft woods in relation to their shear strengths and planing difficulty is listed below.



	Type	Shear (PSI)
 Increasing Difficulty 	Black Locust	2,480
	Sugar Maple	2,330
	Pecan Hickory	2,080
	White Oak	2,000
	White Ash	1,950
	Black Cherry	1,700
	American Elm	1,510
	Black Walnut	1,370
	Red Alder	1,080
	Basswood	980
Cottonwood	930	

Figure 37. Common hardwood shear strengths.



	Type	Shear (PSI)
 Increasing Difficulty 	Western Larch	1,410
	Tamarack	1,280
	Douglas Fir	1,160
	Alaska Cedar	1,130
	Sitka Spruce	1,150
	Sugar Pine	1,050
	Cypress	1,000
	Redwood (OG)	940
	Red Cedar	860
	White Pine	850
Balsam Fir	710	

Figure 38. Common softwood shear strengths.



Planing Difficulties

The following descriptions of defects will give you some possible answers to problems you may encounter while planing different materials. Possible solutions follow the descriptions.

Chipped Grain - usually a result of cutting against the grain, or planing wood with knots or excessive amount of cross grain. Chipped grain can also be caused by dull knives or misaligned chipbreaker. Often, chipped grain can be avoided by slowing down the feed rate and by taking shallow cuts. If those options do not work, inspect your lumber and determine if its grain pattern is causing the problem. If the wood does not show substantial crossgrain, inspect your knives for sharpness and inspect the chipbreaker for proper alignment. See the Adjustment Section.

Fuzzy Grain - Usually caused by surfacing lumber with too high a moisture content. Sometimes fuzzy grain is a characteristic of some woods, such as basswood. Fuzzy grain can also be caused by dull knives or an incorrect grinding bevel. Check with a moisture meter. If moisture is greater than 20%, sticker the wood and allow to dry. Otherwise, inspect knife condition.

Glossy Surface - Usually caused by dull knives taking shallow cuts at a slow feed speed. Surface gloss will usually be accompanied by overheating. Often, lumber will be scorched and eventually, damage to knives will occur. If knives are sharp on inspection, increase feed speed and/or cutting depth.

Snipe - Occurs when board ends have more material removed than the rest of the board. Usually caused when one or both of the bed rollers are set too high. Can also be caused by the chipbreaker or pressure bar being set too high. However, small amount of snipe is inevitable.

Snipe can be minimized by proper adjustment of the planer's components, but complete removal of snipe is extremely unlikely. More likely, you will be able to reduce it to a tolerance of .002".

If snipe under that level is a problem, consider planing lumber longer than your intended work length and cut off the excess after planing is completed.

Uneven Knife Marks - Usually an indication that cutterhead bearings are beginning to show signs of deterioration. Uneven knife marks can also occur when the chipbreaker is set too high. Inspect cutterhead bearings if re-adjustment of the chipbreaker fails to remedy the situation.

Chatter Marks - Usually caused by incorrect chipbreaker and pressure bar setting heights. Chatter marks can also be caused by running a narrow wood piece through the planer at either the right or left end of the cutterhead. Chatter, like uneven knife marks, will show in the form of a "washboard" look. Chatter marks are more likely to be inconsistent in appearance than uneven knife marks.

Wavy Surface - Caused by poor knife height adjustment, wavy surface appears when one knife is taking deeper cuts than the rest of the knives. Remedy by re-setting the knives to a tolerance of $\pm .001$ ".

Pitch & Glue Build-up - Glue and resin build-up on the rollers and cutterhead will cause overheating by decreasing cutting sharpness while increasing drag in the feed mechanism. The result can include scorched lumber as well as uneven knife marks and chatter.

Chip Marks - Occur when chips aren't properly expelled from the cutterhead. The knives catch the chips and drag them across the lumber being planed. Chips tend to be random and non-uniform (as compared to chipped grain). Can be caused by exhaust blockage or too much room between the cutterhead and chip deflector. Using a dust collection system in combination with the planer can help reduce chip marks. Inspect the chip deflector and re-adjust as described earlier in the text.



SECTION 7: MAINTENANCE

General

Make a habit of inspecting your planer each time you use it. Check for the following conditions and repair or replace when necessary.

1. Loose mounting bolts.
2. Worn switch.
3. Worn or damaged cords and plugs.
4. Damaged V-belts.
5. Any other condition that could hamper the safe operation of this machine.



Table

The table and other non-painted surfaces on the Model G1021 should be protected against rust and pitting. Wiping the table clean after every use ensures that moisture from wood dust isn't allowed to trap moisture against bare metal surfaces.

Some woodworkers recommend using automotive paste wax on exposed steel and cast iron surfaces. The wax provides a layer of protection, as well as reducing friction between lumber and the table, making cuts faster and smoother. Avoid waxes that contain silicone or other synthetic ingredients. These materials can find their way into lumber that's being worked, and can make staining and finishing difficult. If you use paste wax, make sure that it's 100% Carnauba wax.



Knives

We recommend that dull knives be taken to a professional knife sharpener. Improperly sharpened knives can cause a number of defects to lumber and put unnecessary load on the motor and drive systems. If you can avoid sharpening knives yourself, allow them to be handled by a trained sharpener.

If you must do the job yourself, take note of the following information.

You will be dealing with a cutting angle of 35 degrees and a grinding angle of 35 degrees. See **Figure 39**. The grinding angle has been determined by the factory to be the best compromise for planing a wide variety of wood types. In most cases, that angle will produce excellent work. If you choose to change the angle of your bevel, be sure to consult with a trained sharpener, or with a reference book before you commit to changing the angle of bevel.

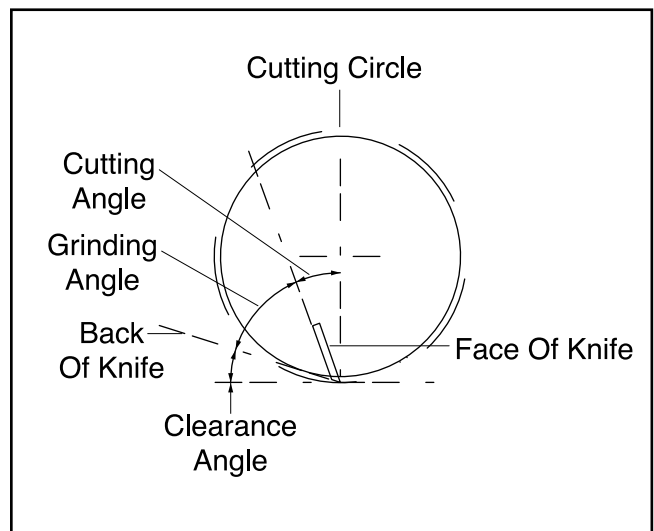

Figure 39. Recommended sharpening angles.



Lubrication

The Model G1033 features factory-sealed bearings. A sealed bearing requires no lubrication during its lifetime. Should a bearing fail, your planer will probably develop a noticeable rumble, which will increase when the machine is put under load. If allowed to get worse, overheating of the journal containing the bad bearing could occur. If the bad bearing is not replaced, it will eventually seize - possibly doing damage to other parts of the machine. Bearings are standard sizes and can be replaced through Grizzly.

Proper lubrication of other components of the Model G1033 are essential for long life and trouble-free operation. Below is a list of components that require periodic lubrication. Schedules are based on daily use. Adjust accordingly for your level of use.

Columns/Lead Screws - The four columns should be lubricated weekly with light oil. Unfasten dust covers to gain access. The four lead screws should be lubricated with general purpose grease once a month.

Worm Gear - The worn gear should be inspected monthly and lubricated when needed. Remove the worm gear box to inspect. See parts diagram for location.

Chain - The table height adjustment chain should be inspected monthly and lubricated when needed. A good quality bicycle chain lubricant works well for periodic lubrication.

Gear Box - Gear box oil should be drained after the first 20 hours of operation. See **Figure 40**. Replace with 80W-90W gear oil. Inspect levels periodically and change yearly. Replace gear oil more frequently under heavy use. Fill until oil reaches the top of the filler plug port for correct oil level.

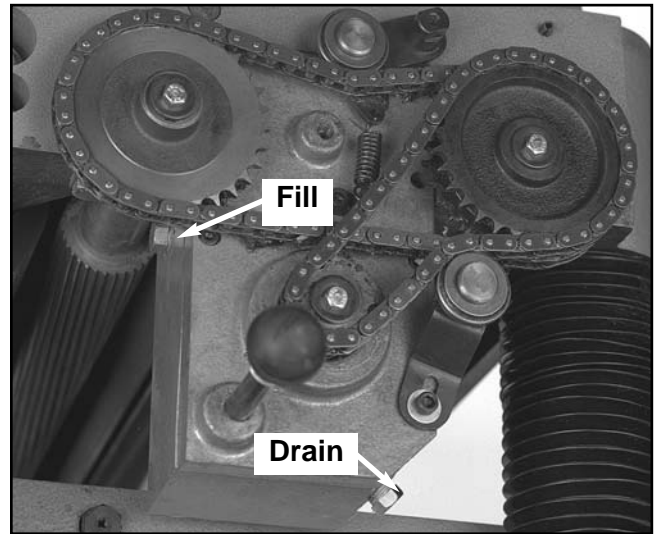

Figure 40. Gearbox fill and drain points.

Drive Chain - The drive chain should be inspected and lubricated monthly. Check sprocket, chain and cotter pin during inspection. Use a general purpose grease. Some chains will have master links instead of cotter pins.

Feed Rollers - Daily lubrication of feed rollers is crucial to the operation of your planer. Lubricate before start-up. Each end of each power feed roller has an oiling port located on the top of the head casting. See **Figure 41**. Apply a light oil, making sure that the lubricant penetrates the bearing.



Figure 41. Feed roller lubrication points.

Clean and lubricate the chain sprockets as needed. The gearbox oil should be checked before the first use. It is full when oil begins dribbling out of the fill hole. Oil should be replaced yearly. Use 80-90 Wt. gear oil in normal situations. Use 50 wt. motor oil for unheated, winter shops. See **Adjustment Section**.

The lead screws and columns should be wiped of any grease and dust build up once a week. They should be relubricated with light machine oil. See **Figure 42**.

The infeed/outfeed pressure setscrews double as lubrication ports for the rollers. Add 1-2 drops of light machine oil to all ports before each use. See **Figures 43 and 44**.

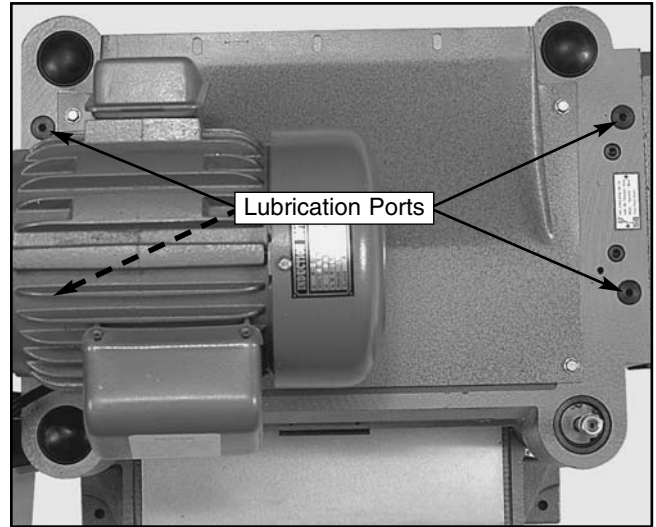

Figure 43. Lubrication ports on top of machine.

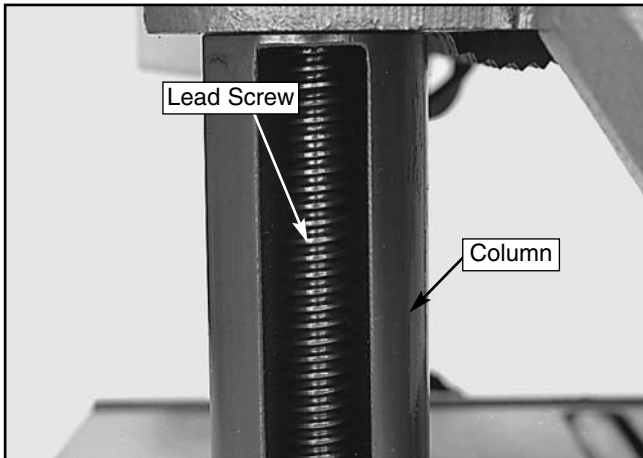

Figure 42. Lead Screw inside of column.

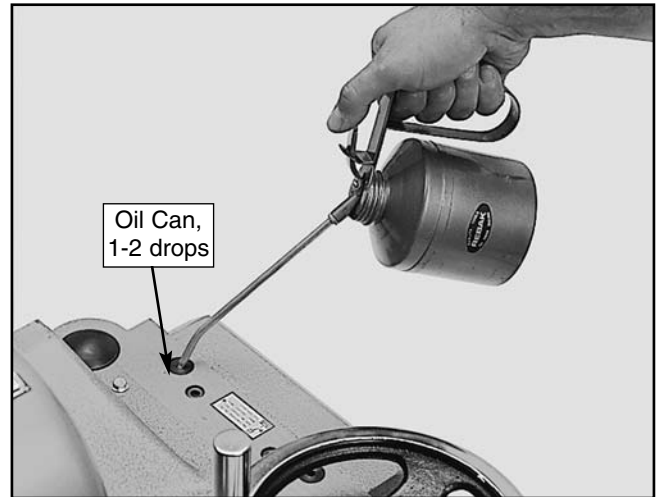

Figure 44. Oiling lubrication ports.



SECTION 8: CLOSURE

The following pages contain parts diagrams, parts lists, general machine data and warranty/return information for your Model G1021 Planer.

If you need parts or help in assembling your machine, or if you need operational information, we encourage you to call the Grizzly Industrial Service Department. Our trained service technicians will be glad to help you.

If you have comments dealing specifically with this manual, please write to our Bellingham, Washington location using the address in the Introduction. The specifications, drawings, and photographs illustrated in this manual represent the Model G1021 as supplied when the manual was prepared. However, due to Grizzly's policy of continuous improvement, changes may be made at any time with no obligation on the part of Grizzly. Whenever possible, though, we send manual updates to all owners of a particular tool or machine. Should you receive one, add the new information to this manual and keep it for reference.

We have included some important safety measures that are essential to this machine's operation. While most safety measures are generally universal, Grizzly reminds you that each workshop is different and safety rules should be considered *as they apply to your specific situation*.

WARNING

Always wear ANSI-approved safety glasses or goggles and hearing protection when operating equipment — particularly when testing new tools or machinery. Do not allow visitors into your workshop when testing or operating equipment. Serious injury may occur.

We recommend you keep a copy of our current catalog for complete information regarding Grizzly's warranty and return policy. If you need additional technical information relating to this machine, or if you need general assistance or replacement parts, please contact the Service Department listed in *Section 3: Introduction*.

Additional information sources are necessary to realize the full potential of this machine. Trade journals, woodworking magazines, and your local library are good places to start.



WARNING

The Model G1021 was specifically designed for wood cutting operations. **DO NOT MODIFY AND/OR USE THIS PLANER FOR ANY OTHER PURPOSE.** Modifications or improper use of this tool will void the warranty. If you are confused about any aspect of this machine, **DO NOT** use it until you have answered all your questions. Serious injury may occur.

WARNING

Like all power tools, there is danger associated with the Model G1021 15" Planer. Use the tool with respect and caution to lessen the possibility of mechanical damage or operator injury. If normal safety precautions are overlooked or ignored. Serious injury may occur.

TROUBLESHOOTING

This section covers the most common processing problems encountered in planing and what to do about them. Do not make any adjustments until planer is unplugged and moving parts have come to a complete stop.

SYMPTOM	POSSIBLE CAUSE	CORRECTIVE ACTION
Motor will not start.	<ol style="list-style-type: none"> 1. Low voltage. 2. Open circuit in motor or loose connections. 	<ol style="list-style-type: none"> 1. Check power line for proper voltage. 2. Inspect all lead connections on motor for loose or open connections.
Motor will not start; fuses or circuit breakers blow.	<ol style="list-style-type: none"> 1. Short circuit in line cord or plug. 2. Short circuit in motor or loose connections. 3. Incorrect fuses or circuit breakers in power line. 	<ol style="list-style-type: none"> 1. Inspect cord or plug for damaged insulation and shorted wires. 2. Inspect all connections on motor for loose or shorted terminals or worn insulation. 3. Install correct fuses or circuit breakers.
Motor overheats.	<ol style="list-style-type: none"> 1. Motor overloaded. 2. Air circulation through the motor restricted. 	<ol style="list-style-type: none"> 1. Reduce load on motor. 2. Clean out motor to provide normal air circulation.
Motor stalls (resulting in blown fuses or tripped circuit).	<ol style="list-style-type: none"> 1. Short circuit in motor or loose connections. 2. Low voltage. 3. Incorrect fuses or circuit breakers in power line. 4. Motor overloaded. 	<ol style="list-style-type: none"> 1. Inspect connections on motor for loose or shorted terminals or worn insulation. 2. Correct the low voltage conditions. 3. Install correct fuses or circuit breakers. 4. Reduce load on motor.
Machine slows when operating.	<ol style="list-style-type: none"> 1. Feed rate too high. 2. Depth of cut too great. 	<ol style="list-style-type: none"> 1. Feed workpiece slower. 2. Reduce depth of cut.
Loud, repetitious noise coming from machine	<ol style="list-style-type: none"> 1. Pulley setscrews or keys are missing or loose. 2. Motor fan is hitting the cover. 3. V-belt is defective 	<ol style="list-style-type: none"> 1. Inspect keys and setscrews. Replace or tighten if necessary. 2. Tighten fan or shim cover. 3. Replace V-belt. See Maintenance.
Machine is loud when cutting. Overheats or bogs down in the cut.	<ol style="list-style-type: none"> 1. Excessive depth of cut. 2. Knives are dull 	<ol style="list-style-type: none"> 1. Decrease depth of cut. 2. Sharpen knives.
Infeed roller marks are left on the workpiece.	Depth of cut too shallow.	Increase depth of cut.
Outfeed roller marks are left on right side of workpiece.	Too much spring tension on feed roller.	Refer to Feed Roller Pressure section for adjustment.
Cannot control snipe.	Long or heavy board sags as it enters and exits.	Lift up on unsupported end of board as it enters and exits cutterhead.
Chip buildup on outfeed roller.	Chips working their way back under the chip deflector.	Lay duct tape over the mounting bolts along the outside edge to seal any possible gaps.
Machine howls on startup.	Chip deflector too close to the cutterhead.	Move back 1/8" to 1/4" from the cutterhead.
Table moves down while cutting.	Knives dull	Replace knives.

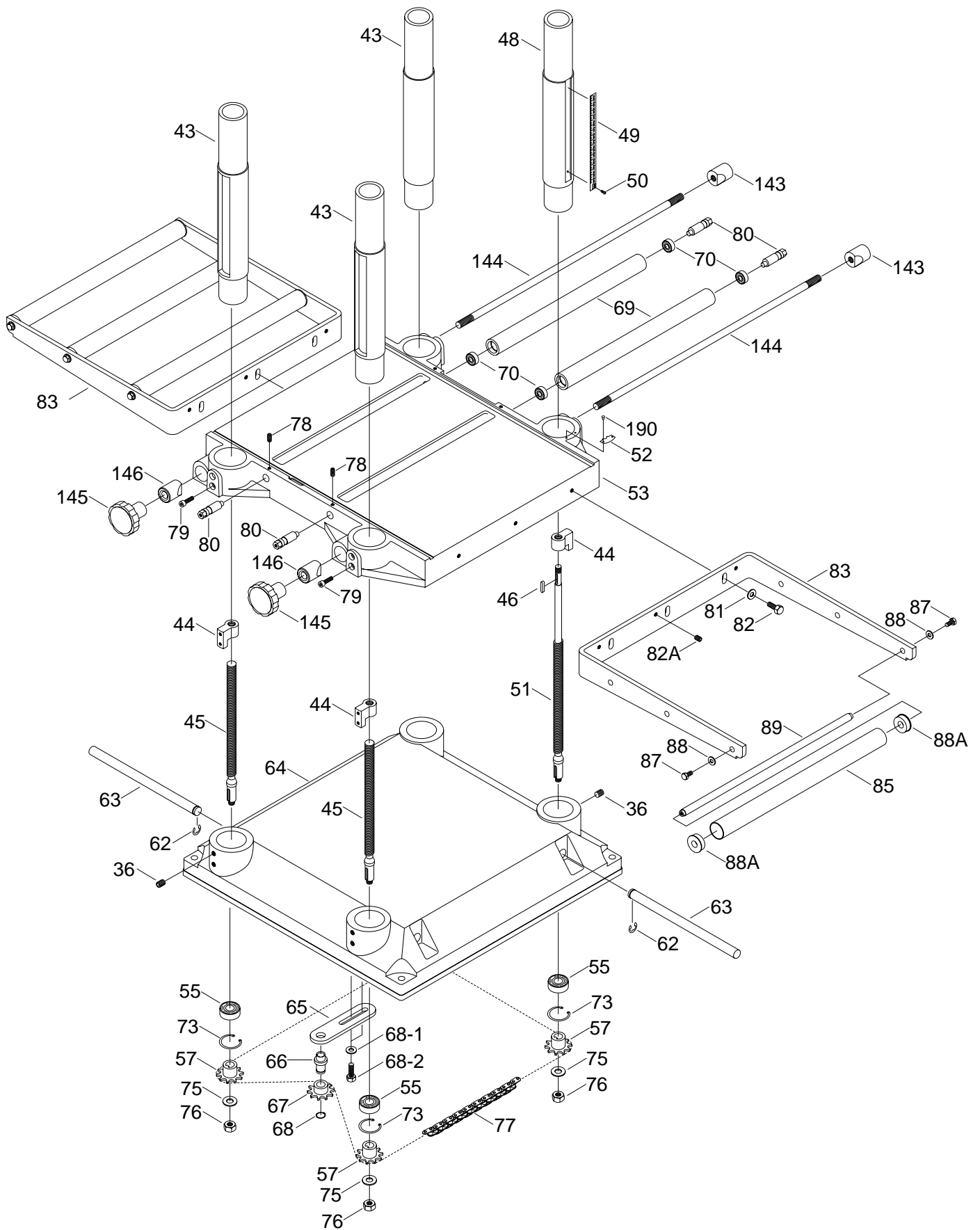

SEE PAGE 41-42 FOR REFERENCE NUMBER LISTING

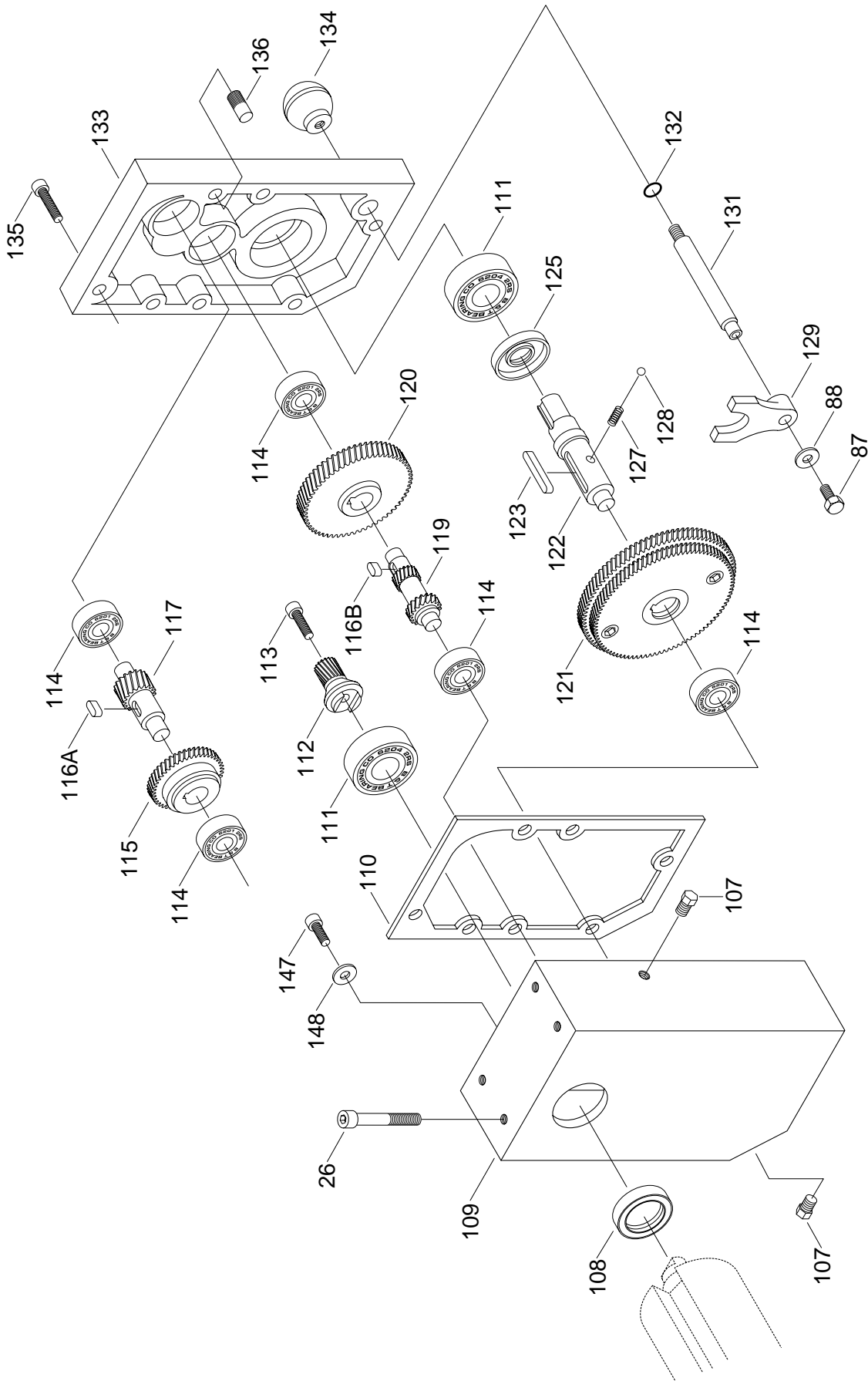

SEE PAGE 41-42 FOR REFERENCE NUMBER LISTING

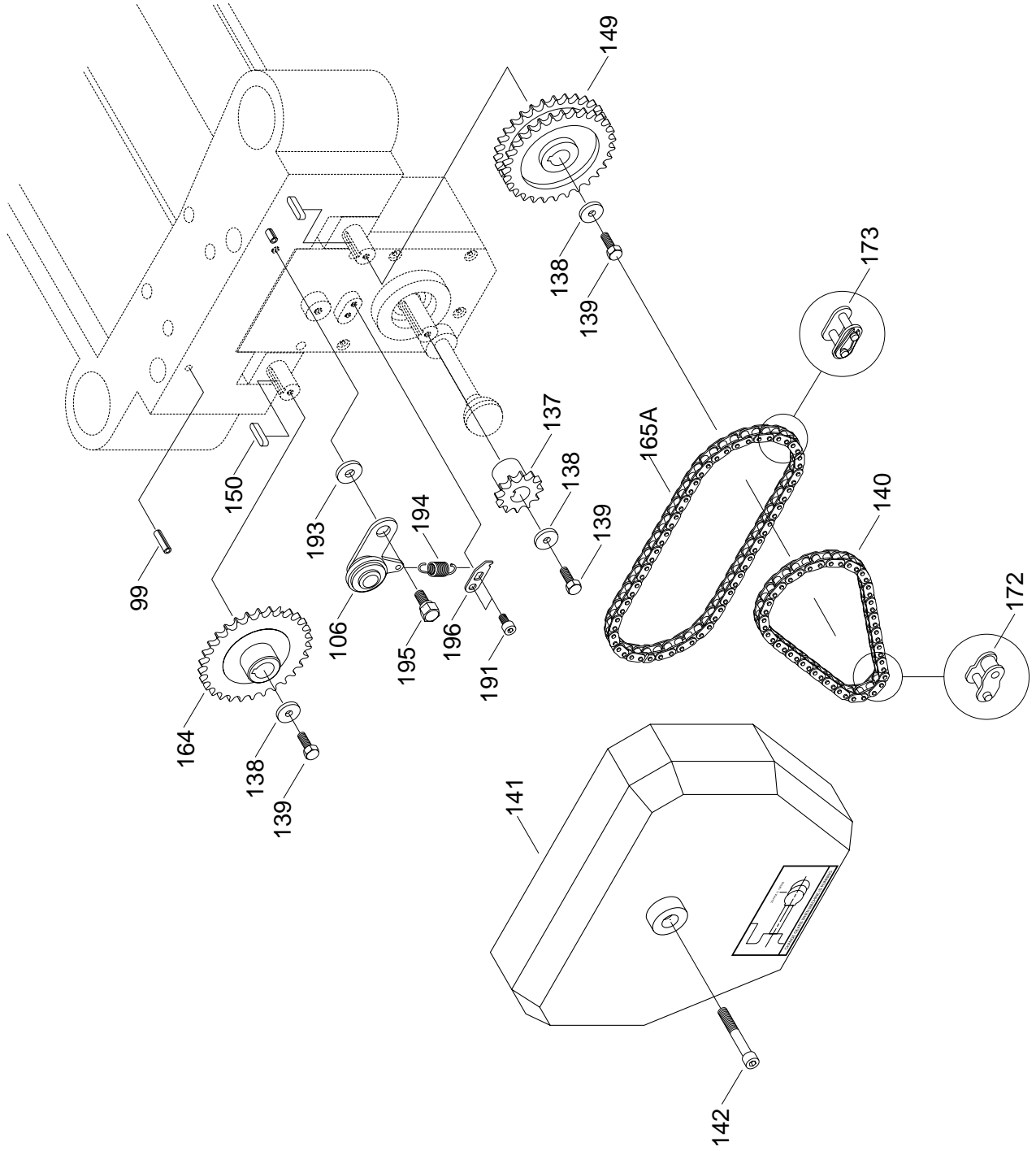

Ref#	Part#	Description
001	P1021001	PULLEY COVER
002	PFB01M	FLANGE BOLT M6 - 1.0 x 12mm
003	P1021003	V-BELT, SET OF 3
004	PB07M	HEX BOLT M8 - 1.25 x 25mm
005	P1021005	SPECIAL WASHER
006	PB13M	HEX BOLT M10 - 1.5 x 80mm
007	P1021007	CUTTERHEAD PULLEY
008	P1021008	MOTOR PULLEY
012	P1021012	SPACER
013	P1021013	BELT HOUSING
014	PB14M	HEX BOLT M10 - 1.5 x 35mm
015	PW04M	FLAT WASHER 10mm
016	P1021016	MOTOR
017	P1021017	MOTOR PLATE
018	PB15M	HEX BOLT M8 - 1.25 x 35mm
019	PW01M	FLAT WASHER 8mm
020	PN03M	HEX NUT M8 - 1.25
021	P1021021	COLUMN CAP
022	P1021022	HEAD CASTING
023	P1021023	CHIP DEFLECTOR
025	P1021025	TENSIONING SETSCREW
026	PSB05M	CAP SCREW M8 - 1.25 x 50mm
027	PSS11M	SETSCREW M6 - 1.0 x 16mm
028	P1021028	CHIP BREAKER SPRING
030	PN08M	HEX NUT M10 - 1.25
031	PW04M	FLAT WASHER 10mm
31A	P1021031A	DIRECTION SCALE
032	P1021032	HANDLE
033	P1021033	HEIGHT HANDWHEEL
034	PR22M	SNAP RING 38mm
035	P1021035	BUSHING
036	PSS13M	SETSCREW M10 - 1.5 x 12mm
038	PSB26M	CAP SCREW M6 - 1.0 x 12mm
040	G4572	2HP MAGNETIC SWITCH
041	PS08	PHLP HD SCREW 10 - 24 x 3/4"
042	P1021042	SWITCH MOUNT
043	P1021043	COLUMN
044	P1021044	SPINDLE NUT
045	P1021045	ELEV. LEAD SCREW, SHORT
046	PK48M	KEY
048	P1021048	COLUMN
049	P1021049	SCALE
050	PS12M	PHLP HD SCREW M3 - 0.5 x 6mm
051	P1021051	ELEVATION SPINDLE, LONG
052	P1021052	POINTER
053	P1021053	TABLE
055	P6202	BEARING 6202 - 2RS
057	P1021057	SPROCKET
062	PEC05M	E-CLIP 15mm

Ref#	Part#	Description
063	P1021063	LIFTING HANDLE
064	P1021064	BASE
065	P1021065	IDLER BRACKET
066	P1021066	SHAFT
067	P1021067	IDLER SPROCKET
068	PR02M	SNAP RING 14mm
68-1	PW01M	FLAT WASHER 8mm
68-2	PB07M	HEX BOLT M8 - 1.25 x 25mm
69	P1021069	TABLE ROLLER
070	P608	BEARING 608 - 2RS
073	PR21M	SNAP RING 35mm
075	PW04M	FLAT WASHER 10mm
076	PN02M	HEX NUT M10 - 1.5
077	P1021077	CHAIN
078	PSS04M	SETSCREW M6 - 1.0 x 12mm
079	PSB02M	CAP SCREW M6 - 1.0 x 20mm
080	P1021080	TABLE ROLLER SHAFT
081	PW01M	FLAT WASHER 8mm
082	PB09M	HEX BOLT M8 - 1.25 x 20mm
82A	PSS14M	SETSCREW M8 - 1.25 x 12mm
083	P1021083	ROLLER FRAME
085	P1021085	ROLLER
087	PB02M	HEX BOLT M6 - 1.0 x 12mm
088	PW03M	FLAT WASHER 6mm
88A	P1021088A	PLASTIC ROLLER BUSH
089	P1021089	ROLLER ROD
090	PSS11M	SETSCREW M6 - 1.0 x 16mm
90-1	PN01M	HEX NUT M6 - 1.0
091	PB09M	HEX BOLT M8 - 1.25 x 20mm
092	P1021092	PLATE
094	PSS14M	SETSCREW M8 - 1.25 x 12mm
097	P1021097	UPPER COVER
099	PRP07M	ROLL PIN 6 x 20mm
100	P6205	BEARING 6205 - 2RS
101	PK41M	KEY 8 x 8 x 40mm
102	P1021102	CUTTERHEAD
103	P1021103	SPRING
104	P1021104	GIB BOLT
105	P1021105	GIB
106	P1033099	CHAIN TENSIONER
107	P1021107	OIL PLUG
108	P1021108	OIL SEAL 28 x 40 x 8mm
109	P1021109	GEAR BOX
110	P1021110	GASKET
111	P6204	BEARING 6204 - 2RS
112	P1021112	GEAR
113	PSB02M	CAP SCREW M6 - 1.0 x 20mm
114	P6201	BEARING 6201 - 2RS
115	P1021115	GEAR

Ref#	Part#	Description
116B	PK06M	KEY 5 x 5 x 10mm
117	P1021117	GEAR AND SHAFT
119	P1021119	GEAR, 2 SPEED
120	P1021120	GEAR
121	P1021121	DOUBLE GEAR
122	P1021122	SHAFT
123	PK11M	KEY 6 x 6 x 40mm
124	PK21M	KEY 5 x 5 x 23mm
125	P1021125	OIL SEAL 25 x 47 x 7mm
127	P1021127	SPRING
128	P1021128	BALL 6mm
129	P1021129	SHIFTER
131	P1021131	SHIFTING HANDLE
132	P1021132	O-RING 12mm
133	P1021133	GEAR CASE
134	P1021134	KNOB
135	PSB06M	CAP SCREW M6 - 1.0 x 25mm
136	P1021136	PIN
137	P1021137	SPROCKET
138	P1021138	SPECIAL WASHER
139	PB18M	HEX BOLT M6 - 1.0 x 25mm
140	P1021140	CHAIN, 23 LINKS
141	P1021141	CHAIN COVER
142	PSB05M	CAP SCREW M8 - 1.25 x 50mm
143	P1021143	THREADED GIB
144	P1021144	LOCKING ROD
145	P1021145	LOCKING KNOB
146	P1021146	GIB
147	PSB01M	CAP SCREW M6 - 1.0 x 16mm
148	PW03M	FLAT WASHER 6mm
149	P1021149	SPROCKET
150	PK21M	KEY 5 x 5 x 23mm
151	P1021151	OUTFEED ROLLER
152	P1021152	SPRING
153	P1021153	BUSHING BLOCK
154	P1021154	CHIPBREAKER
155	PN01M	HEX NUT M6 - 1.0
156	PSS11M	SET SCREW M6 - 1.0 x 16mm

Ref#	Part#	Description
157	P1021157	CHIPBREAKER ADJUST ROD
159	PR05M	E-CLIP 15mm
160	P1021160	SPACER
161	P1021161	ANTI-KICKBACK FINGER
162	P1021162	SHAFT
163	P1021163	INFEED ROLLER
164	P1021164	SPROCKET
165A	P1021165A	CHAIN, 31 LINKS
166	P1021166	KNIFE GAUGE
167	PWR810	WRENCH, 8 x 10mm
167A	PWR1214	WRENCH, 12 x 14mm
168	P1021168	CHIP CHUTE
169	G1197	COMPLETE STAND
170	G1196	KNIFE, SET OF 3
172	PHL01	REPLACEMENT HALF LINK
173	PML01	REPLACEMENT MASTER LINK
174	P1021174	DEPTH LIMITER
175	PFH05M	FLAT HD SCRW M5 - 0.8 x 12mm
176	P1033097	RETAINER
177	PR03M	SNAP RING 12mm
178	P1021178	PIVOT ROD
179	PN09M	HEX NUT M12 - 1.75
180	P1021180	STRAIN RELIEF
181	PSW01-1	SWITCH COVER SCREW
182	PLW03M	LOCK WASHER 6mm
183	PWRCRD220L	POWER CORD 220V, LONG
184	PWRCRD220S	POWER CORD 220V, SHORT
185	PK15M	KEY 5 x 5 x 35mm
186	PAW03M	ALLEN® WRENCH 3mm
187	PAW04M	ALLEN® WRENCH 4mm
188	PAW05M	ALLEN® WRENCH 5mm
189	PAW06M	ALLEN® WRENCH 6mm
191	PSB04M	CAP SCREW M6 - 1.0 x 10mm
192	P1021192	LABEL
193	P1033105	SPACER
194	P1033104	SPRING
195	P1033102	SHAFT
196	P1033103	HANGER

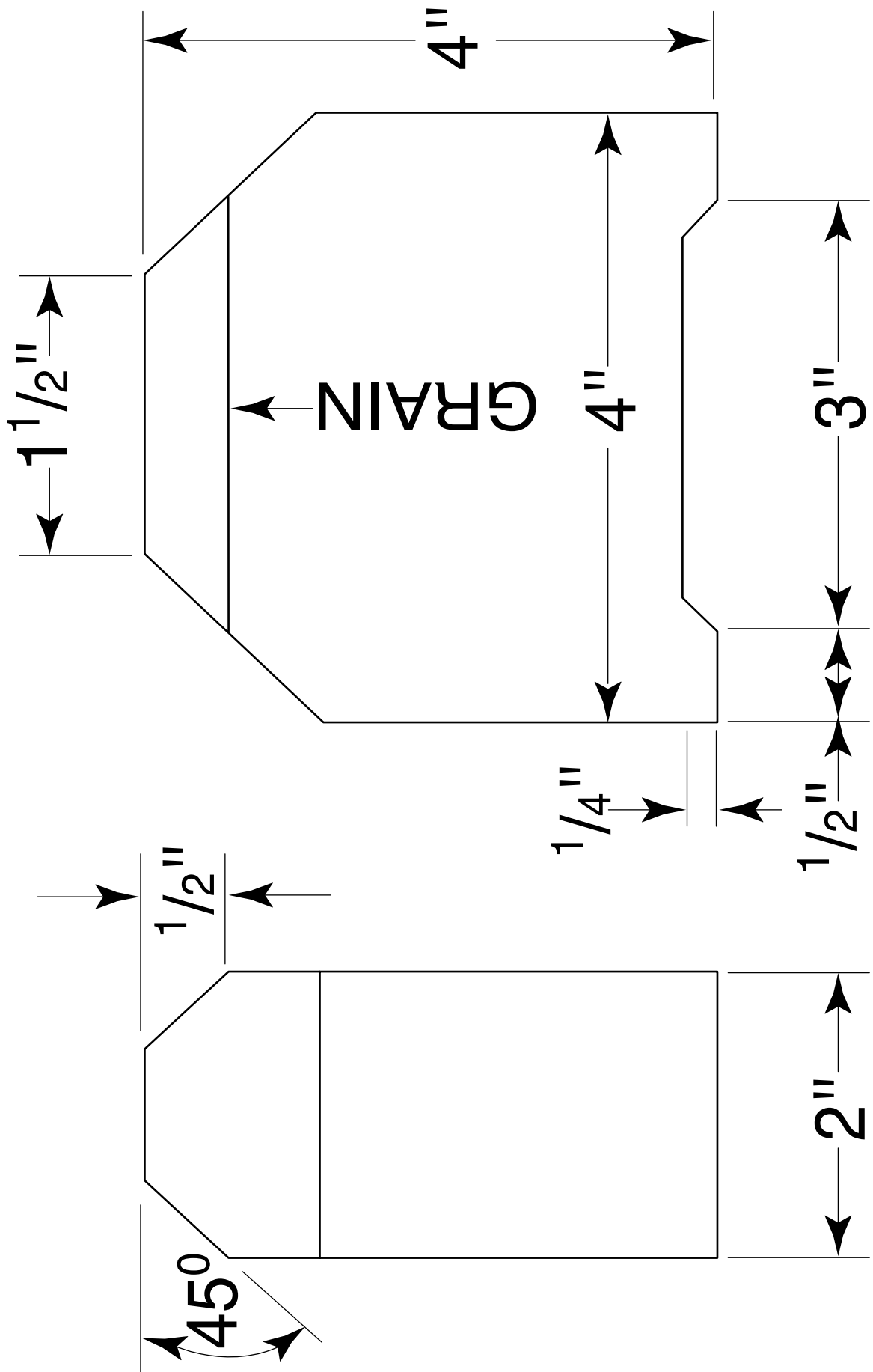

WARRANTY AND RETURNS

Grizzly Industrial, Inc. warrants every product it sells for a period of **1 year** to the original purchaser from the date of purchase. This warranty does not apply to defects due directly or indirectly to misuse, abuse, negligence, accidents, repairs or alterations or lack of maintenance. This is Grizzly's sole written warranty and any and all warranties that may be implied by law, including any merchantability or fitness, for any particular purpose, are hereby limited to the duration of this written warranty. We do not warrant or represent that the merchandise complies with the provisions of any law or acts unless the manufacturer so warrants. In no event shall Grizzly's liability under this warranty exceed the purchase price paid for the product and any legal actions brought against Grizzly shall be tried in the State of Washington, County of Whatcom.

We shall in no event be liable for death, injuries to persons or property or for incidental, contingent, special, or consequential damages arising from the use of our products.

To take advantage of this warranty, contact us by mail or phone and give us all the details. We will then issue you a "Return Number", which must be clearly posted on the outside as well as the inside of the carton. We will not accept any item back without this number. Proof of purchase must accompany the merchandise.

The manufacturers reserve the right to change specifications at any time because they constantly strive to achieve better quality equipment. We make every effort to ensure that our products meet high quality and durability standards and we hope you never need to use this warranty.

Please feel free to write or call us if you have any questions about the machine or the manual.

Thank you again for your business and continued support. We hope to serve you again soon.