

TOSHIBA

PORTÉGÉ M300

Portable Personal Computer

User's Manual

Copyright

© 2004 by TOSHIBA Corporation. All rights reserved. Under the copyright laws, this manual cannot be reproduced in any form without the prior written permission of TOSHIBA. No patent liability is assumed, with respect to the use of the information contained herein.

TOSHIBA PORTÉGÉ M300 Portable Personal Computer User's Manual

First edition, December 2004

Copyright authority for music, movies, computer programs, data bases and other intellectual property covered by copyright laws belongs to the author or to the copyright owner. Copyrighted material can be reproduced only for personal use or use within the home. Any other use beyond that stipulated above (including conversion to digital format, alteration, transfer of copied material and distribution on a network) without the permission of the copyright owner is a violation of copyright or author's rights and is subject to civil damages or criminal action. Please comply with copyright laws in making any reproduction from this manual.

Disclaimer

This manual has been validated and reviewed for accuracy. The instructions and descriptions it contains are accurate for the TOSHIBA PORTÉGÉ M300 Portable Personal Computer at the time of this manual's production. However, succeeding computers and manuals are subject to change without notice. TOSHIBA assumes no liability for damages incurred directly or indirectly from errors, omissions or discrepancies between the computer and the manual.

Trademarks

IBM is a registered trademark and IBM PC is a trademark of International Business Machines Corporation.

Intel, Intel SpeedStep, Pentium, Celeron and Centrino are trademarks or registered trademarks of Intel Corporation.

Windows and Microsoft are registered trademarks of Microsoft Corporation.

Photo CD is a trademark of Eastman Kodak.

Sonic RecordNow! is registered trademarks of Sonic Solutions.

Bluetooth is a trademark owned by its proprietor and used by TOSHIBA under license.

i.LINK is trademark and registered trademark of Sony Corporation.

InterVideo and WinDVD are registered trademarks of the InterVideo Inc.

WinDVD Creator is trademark of the InterVideo Inc.

Other trademarks and registered trademarks not listed above may be used in this manual.

EU Declaration of Conformity

This product is carrying the CE-Mark in accordance with the related



European Directives. Responsible for CE-Marking is TOSHIBA Europe GmbH, Hammfelddamm 8, 41460 Neuss, Germany.

The complete and official EU Declaration of Conformity can be found on TOSHIBA's web site <http://epps.toshiba-teg.com> on the Internet.

Working environment

This product was designed to fulfill the EMC (Electromagnetic Compatibility) requirements for "residential, commercial and light industry environments".

The following environments are not approved:

- Industrial Environments (e.g. environments with a mains voltage > 380V~)

In the following environments the use of this product can be restricted:

- Medical Environments: This product is not certified as a medical product according to the Medical Product Directive 93/42/EEC.
- Vehicle Environments: Please read the operator's manual of the vehicle manufacturer for further restrictions of use.
- Aircraft Environments: Please follow the advices of the flight personnel regarding restrictions of use.

Any consequences resulting from the use of this product in working environments that are not approved or the use is restricted are not the responsibility of TOSHIBA Corporation. The consequences of the use of this product in those working environments may be:

- Interference with other devices or machines in the nearby surrounding area
- Malfunction of or data loss from this product caused by disturbances generated by other devices or machines in the nearby surrounding area

Furthermore, for general safety reasons, the use of this product in environments with explosive atmospheres is not permitted.

CE compliance

This product is labelled with the CE Mark in accordance with the related European Directives, notably Electromagnetic Compatibility Directive 89/336/EEC for the notebook and the electronic accessories including the supplied power adapter, the Radio Equipment and Telecommunications Terminal Equipment Directive 99/5/EEC in case of implemented telecommunication accessories and the Low Voltage Directive 73/23/EEC for the supplied power adapter.

This product and the supplied accessories are designed to observe the related EMC (Electromagnetic Compatibility) and safety standards. However, TOSHIBA cannot guarantee that this product still observes these EMC standards if accessories or cables not manufactured / distributed by TOSHIBA are connected or implemented. To avoid EMC problems in general, the following advice should be observed:

- Only CE marked accessories should be connected / implemented.
- Only best shielded cables should be connected.

Modem warning notice

Conformity Statement

The equipment has been approved to [Commission Decision "CTR21"] for pan-European single terminal connection to the Public Switched Telephone Network (PSTN).

However, due to differences between the individual PSTNs provided in different countries/regions the approval does not, of itself, give an unconditional assurance of successful operation on every PSTN network termination point.

In the event of problems, you should contact your equipment supplier in the first instance.

Network Compatibility Statement

This product is designed to work with, and is compatible with the following networks. It has been tested to and found to conform with the additional requirements conditional in EG 201 121.

Germany	ATAAB AN005,AN006,AN007,AN009,AN010 and DE03,04,05,08,09,12,14,17
Greece	ATAAB AN005,AN006 and GR01,02,03,04
Portugal	ATAAB AN001,005,006,007,011 and P03,04,08,10
Spain	ATAAB AN005,007,012, and ES01
Switzerland	ATAAB AN002
All other countries/regions	ATAAB AN003,004

Specific switch settings or software setup are required for each network, please refer to the relevant sections of the user guide for more details.

The hookflash (timed break register recall) function is subject to separate national type approvals. It has not been tested for conformity to national type regulations, and no guarantee of successful operation of that specific function on specific national networks can be given.

Optical disc drive safety instructions



Be sure to check the international precautions at the end of this section.

Panasonic

DVD-ROM&CD-R/RW UJDA765



- The DVD-ROM&CD-R/RW drive employs a laser system. To ensure proper use of this product, please read this instruction manual carefully and retain for future reference. Should the unit ever require maintenance, contact an authorized service location.
- Use of controls, adjustments or the performance of procedures other than those specified may result in hazardous radiation exposure.
- To prevent direct exposure to the laser beam, do not try to open the enclosure.

Location of the required label

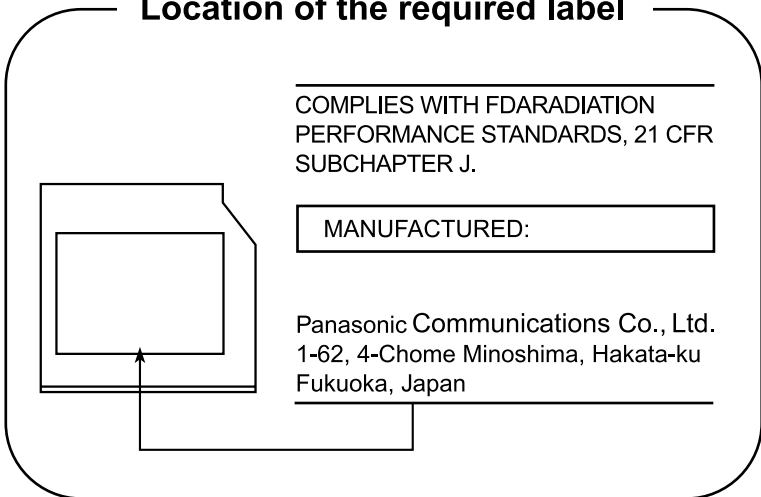

DVD Super Multi UJ-822



- *The DVD Super Multi drive employs a laser system. To ensure proper use of this product, please read this instruction manual carefully and retain for future reference. Should the unit ever require maintenance, contact an authorized service location.*
- *Use of controls, adjustments or the performance of procedures other than those specified may result in hazardous radiation exposure.*
- *To prevent direct exposure to the laser beam, do not try to open the enclosure.*

Location of the required label

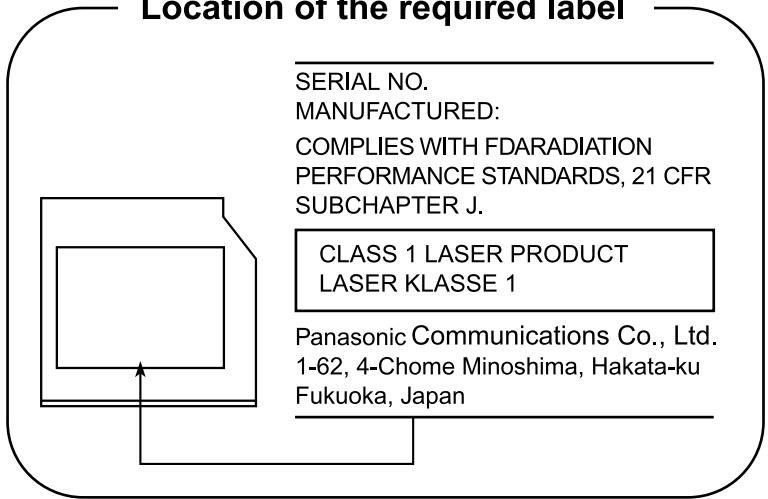

International precautions

CLASS 1 LASER PRODUCT
LASER KLASSE 1 PRODUKT
TO EN 60825-1
クラス1 レーザ 製品

CLASS 1 LASER PRODUCT
LASERSCHUTZKLASSE 1
PRODUKT
TOEN60825

ADVERSEL: USYNLIG
LASERSTRÅLING VED
ÅBNING, NÅR
SIKKERHEDSAF-BRYDER
ER UDE AF FUNKTION.
UNDGÅ UDSÆTTSELSE
FOR STRÅLING

CAUTION: *This appliance contains a laser system and is classified as a "CLASS 1 LASER PRODUCT." To use this model properly, read the instruction manual carefully and keep this manual for your future reference. In case of any trouble with this model, please contact your nearest "AUTHORIZED service station." To prevent direct exposure to the laser beam, do not try to open the enclosure.*

VORSICHT: *Dieses Gerät enthält ein Laser-System und ist als "LASERSCHUTZKLASSE 1 PRODUKT" klassifiziert. Für den richtigen Gebrauch dieses Modells lesen Sie bitte die Bedienungsanleitung sorgfältig durch und bewahren diese bitte als Referenz auf. Falls Probleme mit diesem Modell auftreten, benachrichtigen Sie bitte die nächste "autorisierte Service-Vertretung". Um einen direkten Kontakt mit dem Laserstrahl zu vermeiden darf das Gerät nicht geöffnet werden.*

ADVARSEL: *Denne mærkning er anbragt udvendigt på apparatet og indikerer, at apparatet arbejder med laserstråler af klasse 1, hvilket betyder, at der anvendes laserstråler af svageste klasse, og at man ikke på apparatets yderside kan bilve udsat for utilladelig kraftig stråling.*

**APPARATET BOR KUN ÅBNES AF
FAGFOLK MED SÆRLIGT KENDSKAB
TIL APPARATER MED
LASERSTRÅLER!**

Indvendigt i apparatet er anbragt den her gængsne advarselmærkning, som advarer imod at foretage sådanne indgreb i apparatet, at man kan komme til at udsatte sig for laserstråling.

OBS! Apparaten innehåller laserkomponent som avger laserstråling överstigande gränsen för laserklass 1.

VAROITUS. Suojakoteloä si saa avata. Laite sisältää laserdiodin, joka lähettää näkymätöntä silmille vaarallista lasersäteilyä.

CAUTION: USE OF CONTROLS OR ADJUSTMENTS OR PERFORMANCE OF PROCEDURES OTHER THAN THOSE SPECIFIED IN THE OWNER'S MANUAL MAY RESULT IN HAZARDOUS RADIATION EXPOSURE.

VORSICHT: DIE VERWENDUNG VON ANDEREN STEUERUNGEN ODER EINSTELLUNGEN ODER DAS DURCHFÜHREN VON ANDEREN VORGÄNGEN ALS IN DER BEDIENUNGSANLEITUNG BESCHRIEBEN KÖNNEN GEFÄHRLICHE STRAHLENEXPOSITIONEN ZUR FOLGE HABEN.

Table of Contents

Preface

General Precautions

Chapter 1 : Introduction

Equipment checklist	1-1
Hardware	1-1
Software	1-2
Documentation	1-2
Features	1-3
Special features	1-10
Utilities	1-13
Options	1-15

Chapter 2 : The Grand Tour

Front with the display closed	2-1
Left side	2-2
Right side	2-3
Backside	2-5
Underside	2-6
Front with the display open	2-7
System indicators	2-10
Keyboard indicators	2-11
USB floppy disk drive (optional)	2-12
Optical media drives	2-13
Region codes for DVD drives and media	2-13
Writable discs	2-13
CDs	2-13
DVDs	2-14
Formats	2-14
DVD-ROM&CD-R/RW drive	2-14
DVD Super Multi drive	2-14
AC adaptor	2-15

Chapter 3 : Getting Started

Setting up your work space **3-1**

 General conditions 3-2

 Placement of the computer 3-2

 Seating and posture 3-3

 Lighting 3-3

 Work habits 3-4

Connecting the AC adaptor **3-4**

Opening the display **3-6**

Turning on the power **3-7**

Starting up for the first time. **3-7**

Turning off the power **3-8**

 Shut Down mode (Boot mode) 3-8

 Hibernation mode 3-8

 Standby mode 3-10

Restarting the computer **3-11**

Restoring the preinstalled software **3-12**

 Restoring from Recovery HDD 3-12

 Restoring from the Product Recovery Media 3-14

Chapter 4 : Operating Basics

Using the Touch Pad **4-1**

Using the USB floppy disk drive **4-2**

 Connecting USB floppy disk drive 4-2

 Disconnecting USB floppy disk drive 4-3

Using optical media drives **4-3**

 Loading discs 4-4

 Removing discs 4-5

 How to remove CD/DVD when the disk tray will not open 4-6

Writing CDs on DVD-ROM&CD-R/RW drive **4-7**

 Before writing or rewriting 4-7

 When writing or rewriting 4-8

Writing CD/DVDs on DVD Super Multi drive **4-9**

 Important message 4-9

 Disclaimer 4-9

 Before writing or rewriting 4-9

 When writing or rewriting 4-12

 RecordNow! Basic for TOSHIBA 4-12

 Data Verification 4-13

 DLA for TOSHIBA 4-14

 When WinDVD Creator Platinum is used: 4-14

 How to make a DVD-Video 4-15

 How to learn more about InterVideo WinDVD Creator 4-15

 Important information for use 4-15

Media care	4-17
CD/DVDs	4-17
Floppy disks	4-17
Sound System	4-18
Volume Control	4-18
Microphone level	4-18
Audio controller	4-18
Modem	4-19
Region selection	4-19
Properties menu	4-19
Setting	4-19
Modem Selection	4-20
Dialing Properties	4-20
Connecting	4-20
Disconnecting	4-21
Wireless communications	4-21
Wireless LAN	4-22
Bluetooth wireless technology	4-23
Bluetooth™ Stack for Windows® by TOSHIBA	4-23
Wireless communication switch	4-24
Wireless communication Indicator	4-25
LAN	4-25
LAN cable types	4-25
Connecting LAN cable	4-26
Disconnecting LAN cable	4-26
Cleaning the computer	4-27
Moving the computer	4-27
Heat dispersal	4-28
 <i>Chapter 5: The Keyboard</i>	
Typewriter keys	5-1
Function keys: F1 ... F12	5-2
Soft keys: Fn key combinations	5-2
Emulating keys on enhanced keyboard	5-2
Hot keys	5-3
Fn Sticky key	5-6
Windows special keys	5-7
Keypad overlay	5-7
Turning on the overlays	5-7
Temporarily using normal keyboard (overlay on)	5-8
Temporarily using overlay (overlay off)	5-8
Temporarily changing modes	5-9
Generating ASCII characters	5-9

Chapter 6 : Power and Power-Up Modes

Power conditions	6-1
Power indicators	6-2
Battery indicators	6-2
DC IN indicator	6-3
Power indicator	6-3
Battery types	6-3
Battery pack	6-3
High capacity battery pack (optional)	6-4
Real Time Clock (RTC) battery	6-5
Care and use of the battery pack	6-5
Safety precautions	6-5
Charging the batteries	6-8
Monitoring battery capacity	6-9
Maximizing battery operating time	6-10
Retaining data with power off	6-10
Extending battery life	6-11
Replacing the battery pack	6-12
Removing the battery pack	6-12
Installing the battery pack	6-13
TOSHIBA Password Utility	6-14
User password	6-14
Supervisor password	6-16
Starting the computer by password	6-16
Power-up modes	6-17
Windows utilities	6-17
Hot keys	6-17
Panel power on/off	6-17
System Auto Off	6-17

Chapter 7 : HW Setup

Accessing HW Setup	7-1
HW Setup window	7-1

Chapter 8 : Optional Devices

PC card	8-2
Inserting a PC card	8-2
Removing a PC card	8-2
SD card	8-3
Formatting an SD memory card	8-3
Inserting an SD card	8-4
Removing an SD card	8-4
SD card care	8-5
Creation of a boot disk	8-5

CF (CompactFlash) card	8-5
Inserting a CF card	8-6
Removing a CF card	8-6
CF card care	8-7
Memory expansion	8-7
Installing memory module	8-8
Removing memory module	8-9
Battery pack	8-10
AC adaptor	8-10
Battery charger	8-10
USB floppy disk drive	8-11
External monitor	8-11
i.LINK (IEEE1394)	8-12
Precautions	8-12
Connecting	8-13
Disconnecting	8-13
Advanced Port Replicator III	8-14
Parallel printer	8-15
Security lock	8-16
 <i>Chapter 9: Troubleshooting</i>	
Problem solving process	9-1
Preliminary checklist	9-2
Analyzing the problem	9-2
Hardware and system checklist	9-3
System start-up	9-3
Self test	9-3
Power	9-4
Password	9-7
Keyboard	9-7
Internal LCD display panel	9-8
Hard disk drive	9-8
DVD-ROM&CD-R/RW drive	9-9
DVD Super Multi drive	9-10
USB floppy disk drive	9-11
SD card	9-11
PC card	9-12
CF card	9-12
Infrared port	9-12
Pointing Device	9-13
USB	9-15
Memory expansion	9-15
Sound System	9-16
External monitor	9-16

i.LINK (IEEE1394)	9-17
Modem	9-17
LAN	9-18
Wireless LAN	9-18
Bluetooth	9-19
Printer	9-19
TOSHIBA support	9-20
Before you call	9-20
Where to write	9-20

Appendix A : Specifications

Physical Dimensions	A-1
Environmental Requirements	A-1
Built-in Modem	A-2

Appendix B : Display Controller and Modes

Display controller	B-1
Video modes	B-1
Display settings	B-7

Appendix C : Wireless LAN

Card Specifications	C-1
Radio Characteristics	C-2
Supported Frequency Sub-bands	C-2
Wireless IEEE 802.11 Channels Sets (Revision B and G)	C-3
Wireless IEEE 802.11 Channels Sets (Revision A)	C-4
Wireless Channels Sets (Turbo Mode)	C-5
Wireless Channels Sets (Turbo Mode)	C-5

Appendix D : Bluetooth wireless technology Interoperability

Bluetooth wireless technology and your Health	D-3
Regulatory statements	D-3
General	D-3
European Union (EU) and EFTA	D-3
Canada - Industry Canada (IC)	D-3
Caution: FCC Interference Statement	D-4
Caution: Exposure to Radio Frequency Radiation	D-4
Taiwan	D-5
Using Bluetooth™ Card from TOSHIBA equipment in Japan	D-6
Device Authorization	D-7
Approved Countries/Regions for use (Bluetooth™ wireless technology)	D-8

Appendix E: AC Power Cord and Connectors

Certification agencies..... **E-1**

Appendix F: If your computer is stolen

Glossary

Index

Preface

Congratulations on your purchase of the PORTÉGÉ M300 computer. This powerful notebook computer provides excellent expansion capability, including multimedia devices, and it is designed to provide years of reliable, high-performance computing.

This manual tells how to set up and begin using your PORTÉGÉ M300 computer. It also provides detailed information on configuring your computer, basic operations and care, using optional devices and troubleshooting.

If you are a new user of computers or if you're new to portable computing, first read over the *Introduction* and *The Grand Tour* chapters to familiarize yourself with the computer's features, components and accessory devices. Then read *Getting Started* for step-by-step instructions on setting up your computer.

If you are an experienced computer user, please continue reading the preface to learn how this manual is organized, then become acquainted with this manual by browsing through its pages. Be sure to look over the *Special features* section of the Introduction, to learn about features that are uncommon or unique to the computers and carefully read *HW Setup*.

If you are going to install PC cards or connect external devices such as a monitor, be sure to read Chapter 8, *Optional Devices*.

Manual contents

This manual is composed of the following nine chapters, six appendixes, a glossary and an index.

Chapter 1, *Introduction*, is an overview of the computer's features, capabilities, and options.

Chapter 2, *The Grand Tour*, identifies the components of the computer and briefly explains how they function.

Chapter 3, *Getting Started*, provides a quick overview of how to begin operating your computer and gives tips on safety and designing your work area.

Chapter 4, *Operating Basics*, includes instructions on using the following devices: Touch Pad, USB floppy disk drive, optical media drives, sound system, modem, Wireless communication features, LAN. It also provides tips on care of the computer, floppy disks and CD/DVDs.

Chapter 5, *The Keyboard*, describes special keyboard functions including the keypad overlay and hot keys.

Chapter 6, *Power and Power-Up Modes*, gives details on the computer's power resources and battery save modes and how to set a password.

Chapter 7, *HW Setup*, explains how to configure the computer using the HW Setup program.

Chapter 8, *Optional Devices*, describes the optional hardware available.

Chapter 9, *Troubleshooting*, provides helpful information on how to perform some diagnostic tests, and suggests courses of action if the computer doesn't seem to be working properly.

The *Appendixes* provide technical information about your computer.

The *Glossary* defines general computer terminology and includes a list of acronyms used in the text.

The *Index* quickly directs you to the information contained in this manual.

Conventions

This manual uses the following formats to describe, identify, and highlight terms and operating procedures.

Abbreviations

On first appearance, and whenever necessary for clarity, abbreviations are enclosed in parentheses following their definition. For example: Read Only Memory (ROM). Acronyms are also defined in the Glossary.

Icons

Icons identify ports, dials, and other parts of your computer. The indicator panel also uses icons to identify the components it is providing information on.

Keys

The keyboard keys are used in the text to describe many computer operations. A distinctive typeface identifies the key top symbols as they appear on the keyboard. For example, Enter identifies the **Enter** key.

Key operation

Some operations require you to simultaneously use two or more keys. We identify such operations by the key top symbols separated by a plus sign (+). For example, **Ctrl + C** means you must hold down **Ctrl** and at the same time press **C**. If three keys are used, hold down the first two and at the same time press the third.

ABC

When procedures require an action such as clicking an icon or entering text, the icon's name or the text you are to type in is represented in the type face you see to the left.

Display



ABC

Names of windows or icons or text generated by the computer that appears on its display screen is presented in the type face you see to the left.

Messages

Messages are used in this manual to bring important information to your attention. Each type of message is identified as shown below.



Pay attention! A caution informs you that improper use of equipment or failure to follow instructions may cause data loss or damage your equipment.



Please read. A note is a hint or advice that helps you make best use of your equipment.



Indicates a potentially hazardous situation, which could result in death or serious injury, if you do not follow instructions.

General Precautions

TOSHIBA computers are designed to optimize safety, minimize strain and withstand the rigors of portability. However, certain precautions should be observed to further reduce the risk of personal injury or damage to the computer.

Be certain to read the general precautions below and to note the cautions included in the text of the manual.

Stress injury

Carefully read the *Safety Instruction Manual*. It contains information on prevention of stress injuries to your hands and wrists that can be caused by extensive keyboard use. Chapter 3, *Getting Started*, also includes information on work space design, posture and lighting that can help reduce physical stress.

Heat injury

- Avoid prolonged physical contact with the computer. If the computer is used for long periods, its surface can become very warm. While the temperature will not feel hot to the touch, if you maintain physical contact with the computer for a long time (if you rest the computer on your lap, or if you keep your hands on the palm rest, for example) your skin might suffer low-heat injury.
- If the computer has been used for a long time, avoid direct contact with the metal plate supporting the I/O ports. It can become hot.
- The surface of the AC adaptor can become hot when in use. This condition does not indicate a malfunction. If you need to transport the AC adaptor, disconnect it and let it cool before moving it.
- Do not lay the AC adaptor on a material that is sensitive to heat. The material could be damaged.

Pressure or impact damage

Do not apply heavy pressure to the computer or subject it to strong impact. Excessive pressure or impact can cause damage to computer components or otherwise cause malfunctions.

PC card overheating

Some PC cards can become hot with prolonged use. Overheating of a PC card can result in errors or instability in the PC card operation. Also be careful when you remove a PC card that has been used for a long time.

Mobile phones

Use of mobile phones can interfere with the audio system. Computer operation is not impaired but it is recommended that a distance of 30 cm be maintained between the computer and a mobile phone in use.

Central Processing Unit (“CPU”) Performance Disclaimer

CPU performance in your computer product may vary from specifications under the following conditions:

- use of certain external peripheral products
- use of battery power instead of AC power
- use of certain multimedia games or videos with special effects
- use of standard telephone lines or low speed network connections
- use of complex modeling software, such as high end computer aided design applications
- use of computer in area with low air pressure (high altitude >1,000 meters or >3,280 feet above sea level)
- use of computer at temperatures outside the range of 5°C to 30°C (41°F to 86°F) or >25°C (77°F) at high altitude (all temperature references are approximate and may vary depending on the specific computer model - please refer to appendix A for details).

CPU performance may also vary from specifications due to design configuration.

Introduction

This chapter provides an equipment checklist, and it identifies the computer's features, options and accessories.



Some of the features described in this manual may not function properly if you use an operating system that was not preinstalled by TOSHIBA.

Equipment checklist

Carefully unpack your computer. Save the box and packing materials for future use.

Hardware

Check to make sure you have all the following items:

- PORTÉGÉ M300 Portable Personal Computer
- AC adaptor and power cord (2-pin plug or 3-pin plug)
- Modular cable for modem (optional)

Software

Microsoft® Windows XP Professional

- The following software is preinstalled:
 - Microsoft® Windows XP Professional
 - Microsoft Internet Explorer
 - TOSHIBA Utilities
 - TOSHIBA SD Memory Boot Utility
 - DVD Video Player
 - TOSHIBA TouchPad On/Off Utility
 - TOSHIBA Power Saver
 - TOSHIBA Mobile Extension
 - TOSHIBA Assist
 - TOSHIBA ConfigFree
 - TOSHIBA Zooming Utility
 - TOSHIBA PC Diagnostic Tool
 - TOSHIBA Controls
 - Online manual

Documentation

- *PORTÉGÉ M300 Portable Personal Computer User's Manual*
- *PORTÉGÉ M300 Quickstart*
- *Safety Instruction Manual*
- Warranty information

If any of the items are missing or damaged, contact your dealer immediately.

Features

The computer uses TOSHIBA's advanced Large Scale Integration (LSI), Complementary Metal-Oxide Semiconductor (CMOS) technology extensively to provide compact size, minimum weight, low power usage, and high reliability. This computer incorporates the following features and benefits:

Processor

Built-in	<p>The computer is equipped with an Intel® processor.</p> <ul style="list-style-type: none"> ■ Intel® Pentium® M processor, which incorporates a 64 KB level 1 cache memory and a 2 MB level 2 cache memory. It also supports Enhanced Intel® SpeedStep™ technology. <p>Other processors may be introduced.</p>
-----------------	--------------------------------------------------------------------------------------------------------------------------------------------------------------------------------------------------------------------------------------------------------------------------------------------------------------------------------



Some models in this series carry Intel® Centrino™ technology, which is based on three separate technologies of Intel® Pentium® M, Intel® PRO/Wireless Network Connection, and Intel® 855 Chipset Family. Intel® 855 Chipset Family is a model by whom Intel® Pentium® M processor is installed.

Memory

Built-in	256 MB of memory is installed on the main board.
Expansion slot	The slot accepts a 256, 512 or 1,024 MB memory module for a maximum of 1,280 MB system memory.
Video RAM	Part of system memory is used for Video RAM. 64 MB of RAM is provided for video display.

Power

Battery pack	The computer is powered by one rechargeable lithium-ion battery pack.
RTC battery	The internal RTC battery backs up the Real Time Clock (RTC) and calendar.
AC adaptor	<p>The AC adaptor provides power to the system and recharges the batteries when they are low. It comes with a detachable power cord. It encloses 2-pin or 3-pin plug type.</p> <p>Because it is universal, it can receive a range of AC voltage from 100 to 240 volts; however, the output current varies among different models. Using the wrong model can damage your computer. Refer to the AC adaptor section in Chapter 2, The Grand Tour .</p>

Disks

Hard disk drive (HDD)	<p>Available in four sizes.</p> <ul style="list-style-type: none"> ■ 40.0 billion bytes (37.26 GB) ■ 60.0 billion bytes (55.89 GB) ■ 80.0 billion bytes (74.53 GB) ■ 100.0 billion bytes (93.16 GB) <p>Other hard disk drives may be introduced.</p>
USB floppy disk drive (optional)	Accommodates either 3 1/2" 1.44-megabyte or 720-kilobyte floppy disks. It connects to a USB port.



Computers in this series are configured with one of the following optical media drives. The available optical media drives are described below.

DVD-ROM&CD-R/RW drive

Some models are equipped with a full-size, DVD-ROM&CD-R/RW drive module that lets you run CD/DVDs without using an adaptor. It reads DVD-ROMs at maximum 8 speed and CD-ROMs at maximum 24 speed. It writes CD-R at maximum 24 speed and CD-RW at maximum 24 speed. The drive supports the following formats:

- DVD-ROM
- DVD-Video
- CD-DA
- CD-Text
- Photo CD™ (single/multi-session)
- CD-ROM Mode 1, Mode 2
- CD-ROM XA Mode 2 (Form1, Form2)
- Enhanced CD (CD-EXTRA)
- Addressing Method 2
- CD-R
- CD-RW

DVD Super Multi drive

Some models are equipped with a full-size DVD Super Multi drive module that lets you record data to rewritable CD/DVDs as well as run either 12cm (4.72") or 8cm (3.15") CD/DVDs without using an adaptor. It reads DVD-ROMs at maximum 8 speed and CD-ROMs at maximum 24 speed. It writes CD-R at maximum 24 speed, CD-RW at maximum 10 speed, DVD-R at maximum 2 speed, DVD-RW at maximum 2 speed. DVD+R and DVD+RW at maximum 2.4 speed. DVD-RAM at maximum 2 speed. This drive supports the following formats in addition to DVD-ROM&CD-R/RW drive.



- DVD-R
 - DVD-RW
 - DVD+R
 - DVD+RW
 - DVD-RAM
-

Display

The computer's LCD display panel supports high-resolution video graphics. The LCD screen can be set at a wide range of viewing angles for maximum comfort and readability.

Built-in	12.1" TFT LCD screen 16 M colors, with a resolution of 1024 horizontal × 768 vertical pixels XGA.
Graphics controller	Graphics controller maximizes display performance. Refer to Display Controller and Modes section in Appendix B for more information.

Keyboard

Built-in	85 keys or 86 keys, compatible with IBM® enhanced keyboard, embedded numeric overlay, dedicated cursor control,  and  keys. Refer to Chapter 5, The Keyboard , for details.
-----------------	---------------------------------------------------------------------------------------------------------------------------------------------------------------------------------------------------------------------------------------------------------------------------------------------------------------------------------------------------------------

Pointing Device

Built-in Touch Pad	A Touch Pad and control buttons in the palm rest enable control of the on-screen pointer and scrolling of windows.
---------------------------	--------------------------------------------------------------------------------------------------------------------

Ports

External monitor	Analog VGA port supports VESA DDC2B compatible functions.
Universal Serial Bus (USB 2.0)	The computer has three Universal Serial Bus ports that comply with the USB 2.0 standard, which enables data transfer speeds 40 times faster than the USB 1.1 standard (The ports also support USB 1.1).
Docking interface	This port enables connection of an optional Advanced Port Replicator III described in the Options section.
i.LINK™ (IEEE1394)	This port enables high-speed data transfer directly from external devices such as digital video cameras.

Infrared	The serial infrared port is compatible with Infrared Data Association (IrDA 1.1) standards. It enables cableless 4 Mbps, 1.152 Mbps, 115.2 kbps, 57.6 kbps, 38.4 kbps, 19.2 kbps or 9.6 kbps data transfer with IrDA 1.1 compatible external devices.
-----------------	-------------------------------------------------------------------------------------------------------------------------------------------------------------------------------------------------------------------------------------------------------

Slots

PC card	The PC card slot accommodates one Type II card.
----------------	-------------------------------------------------

CF card	This slot accommodates CompactFlash. You cannot use CompactFlash that does not conform to CompactFlash Association specifications.
----------------	------------------------------------------------------------------------------------------------------------------------------------

SD card	This slot lets you easily transfer data from devices, such as digital cameras and Personal Digital Assistants, that use SD card flash-memory. Refer to Chapter 8, Optional Devices .
----------------	---------------------------------------------------------------------------------------------------------------------------------------------------------------------------------------------------------

Multimedia

Sound system	Windows sound system compatible sound system provides internal speakers and microphone as well as jacks for an external microphone and headphones.
---------------------	----------------------------------------------------------------------------------------------------------------------------------------------------

Headphone jack	A 3.5 mm mini headphone jack enables connection of stereo headphones.
-----------------------	-----------------------------------------------------------------------

Microphone jack	A 3.5 mm mini microphone jack enables connection of a three-conductor mini jack for monaural microphone input.
------------------------	----------------------------------------------------------------------------------------------------------------

Communications

Modem	An internal modem provides capability for data and fax communication. It supports V.90 (V.92). The speed of data transfer and fax depends on analog telephone line conditions. It has a modem jack for connecting to a telephone line. Both of V.90 and V.92 are supported only in USA, Canada, UK, France, Germany and Australia. Only V.90 is available in other regions.
LAN	The computer has built-in support for Ethernet LAN (10 megabits per second, 10BASE-T), Fast Ethernet LAN (100 megabits per second, 100BASE-TX).
Bluetooth	Some computers in this series are equipped with Bluetooth functions. Bluetooth wireless technology eliminates the need for cables between electronic devices such as computers and printers. Bluetooth provides fast, reliable, and secure wireless communication in a small space.

Wireless LAN

Some computers in this series are equipped with a Wireless LAN mini-PCI card that is compatible with other LAN systems based on Direct Sequence Spread Spectrum/Orthogonal Frequency Division Multiplexing radio technology that complies with the IEEE 802.11 Standard (Revision A, B or G), and Turbo Mode.

- Theoretical maximum speed: 54Mbps (IEEE802.11a, 802.11g)
- Theoretical maximum speed: 11Mbps (IEEE802.11b)
- Theoretical maximum speed: 108Mbps (Turbo Mode; Atheros module type)
- Frequency Channel Selection (5 GHz: Revision A / 2.4 GHz: Revision B/G)
- Roaming over multiple channels
- Card Power Management
- Atheros Super G™ or Super AG™ technology (Atheros module type).
- Wired Equivalent Privacy (WEP) data encryption, based on 152 bit encryption algorithm (Atheros module type).
- Wired Equivalent Privacy (WEP) data encryption, based on 128 bit encryption algorithm (Intel module type).
- Advanced Encryption Standard (AES) data encryption, based on 256 bit encryption algorithm (Atheros module type).
- Wi-Fi Protected Access (WPA).



- *The numerical values for display are the theoretical maximums for Wireless LAN standards. The actual values may differ.*
- *The transmission speed over the wireless LAN and the distance over which wireless LAN can reach may vary depending on surrounding electromagnetic environment, obstacles, access point design and configuration, and client design and software/hardware configurations. The Transmit Rate (xx Mbit/s) is the theoretical maximum speed under the IEEE802.11 (a/b/g) standard. The actual transmission speed will be lower than the theoretical maximum speed. To use the Atheros SuperG™ or SuperAG™ function, your client and access point must support the corresponding feature. Performance of these functions may vary depending on the format of data transmitted.*

Wireless communication switch

This switch turns the Wireless LAN/Bluetooth functions on and off.

Security

Security lock slot	Connects an optional security lock to anchor the computer to a desk or other large object.
---------------------------	--------------------------------------------------------------------------------------------

Special features

The following features are either unique to TOSHIBA computers or are advanced features, which make the computer more convenient to use.

TOSHIBA Assist button	Press this button to launch an application automatically. The default is TOSHIBA Assist.
TOSHIBA Presentation button	Press this button to change internal display, external display, simultaneous display, or multi-monitor display.
Hot keys	Key combinations let you quickly change the system configuration directly from the keyboard without running a system configuration program.
Display automatic power off	This feature automatically cuts off power to the computer's LCD display panel when there is no keyboard input for a time specified. Power is restored when any key is pressed. You can specify the time in the <i>Monitor power off</i> item of the <i>Basic Setup</i> tab in TOSHIBA Power Saver.
HDD automatic power off	This feature automatically cuts off power to the hard disk drive when it is not accessed for a time specified. Power is restored when the hard disk is accessed. You can specify the time in the <i>HDD power off</i> item of the <i>Basic Setup</i> tab in TOSHIBA Power Saver.
System automatic Standby/Hibernation	This feature automatically shuts down the system in standby mode or Hibernation mode when there is no input or hardware access for a time specified. You can specify the time and select either System Standby or System hibernation in the <i>System standby</i> and <i>System hibernation</i> items of the <i>Basic Setup</i> tab in TOSHIBA Power Saver.
Keypad overlay	A ten-key pad is integrated into the keyboard. Refer to the Keypad overlay section in Chapter 5, <i>The Keyboard</i> , for instructions on using the keypad overlay.
Power on password	Two levels of password security, supervisor and user, are available to prevent unauthorized access to your computer.

Instant security	A hot key function blanks the LCD screen and disables the computer providing data security.
Intelligent power supply	A microprocessor in the computer's intelligent power supply detects the battery's charge and calculates the remaining battery capacity. It also protects electronic components from abnormal conditions, such as voltage overload from an AC adaptor. You can monitor remaining battery capacity. Use the <i>Battery remaining</i> item in TOSHIBA Power Saver.
Battery save mode	This feature lets you save battery power. You can specify the Power Save Mode in the <i>Profile</i> item in TOSHIBA Power Saver.
Panel power on/off	This feature turns power to the computer off when the computer's LCD display panel is closed and turns it back on when the computer's LCD display panel is opened. You can specify the setting in the <i>When I close the lid</i> item of the <i>Setup Action</i> tab in TOSHIBA Power Saver.
Low battery automatic hibernation	When battery power is exhausted to the point that computer operation cannot be continued, the system automatically enters Hibernation and shuts down. You can specify the setting in the <i>Setup Action</i> tab in TOSHIBA Power Saver.
Heat dispersal	<p>To protect from overheating, the CPU has an internal temperature sensor. If the computer's internal temperature rises to a certain level, the cooling fan is turned on or the processing speed is lowered. Use the <i>Cooling Method</i> item of the <i>Basic Setup</i> tab in TOSHIBA Power Saver.</p> <ul style="list-style-type: none"> <li data-bbox="516 1037 1036 1117">■ Maximum Performance Turns on fan first, then if necessary lowers CPU processing speed. <li data-bbox="516 1125 1036 1204">■ Performance Uses a combination of fan and lowering the CPU processing speed. <li data-bbox="516 1212 1036 1327">■ Battery optimized Lowers the CPU processing speed first, then if necessary turns on the Cooling Method.

Optical media drive power icon

Use this to turn the power of the optical media drive on or off. Clicking on the optical media drive icon on the taskbar will turn the power of the optical media drive on or off. If the optical media drive power is off, the disc tray will not open even if the eject button is pushed. The power of the optical media drive can be turned on using the optical media drive icon.

HDD Protection

Using the acceleration sensor built in the computer, HDD Protection detects vibration, shocks, and those signs in the computer, and automatically moves the HDD (Hard Disk Drive) head to the safe position to reduce the risk of damage that could be caused to the disk by head-to-disk contact.



This function does not guarantee that the HDD will not be damaged.

Hibernation

This feature lets you turn off the power without exiting from your software. The contents of main memory are saved to the hard disk, when you turn on the power again, you can continue working right where you left off. Refer to the [Turning off the power](#) section in Chapter 3, Getting Started, for details.

Standby

If you have to interrupt your work, you can turn off the power without exiting from your software. Data is maintained in the computer's main memory. When you turn on the power again, you can continue working right where you left off.

Utilities

This section describes preinstalled utilities and tells how to start them. For details on operations, refer to each utility's online manual, help files or readme.txt files.

TOSHIBA Power Saver	To access this power savings management program, click start , click Control Panel , click Performance and Maintenance and select the TOSHIBA Power Saver icon.
HW Setup	This program lets you customize your hardware settings according to the way you work with your computer and the peripherals you use. To start the utility, To access this utility, click start , click Control Panel , click Printers and Other Hardware and select the TOSHIBA HWSetup icon.
TOSHIBA Controls	This utility have a section to let you do the following: <ul style="list-style-type: none"> ■ Buttons: Assign applications to the TOSHIBA Presentation button (default setting is the simultaneous display on LCD and CRT with resolution of 1024 × 768.) and to the TOSHIBA Assist button (default setting is the TOSHIBA Assist).
DVD Video Player	The DVD Video Player is used to play DVD-Video. It has an on-screen interface and functions. Click start , point to All Programs , point to InterVideo WinDVD , then click InterVideo WinDVD .
Bluetooth TOSHIBA Stack	This software enables communication between remote Bluetooth devices.
 <i>Bluetooth cannot be used in models that do not have a Bluetooth module installed.</i>	
TOSHIBA SD Memory Boot Utility	The TOSHIBA SD memory boot utility is a utility which can create SD memory card to a boot disk. You can boot TOSHIBA SD Memory Boot Utility from the menu bar as follows. Click start , point to All Programs , point to TOSHIBA , point to Utilities and click SD Memory Boot Utility .
TOSHIBA Zooming Utility	This utility allows you to enlarge or reduce the icon size on the desktop or the application window.

RecordNow! Basic for TOSHIBA

You can create CD/DVDs in several formats including audio CDs that can be played on a standard stereo CD player and data CD/DVDs to store the files and folders on your hard disk drive. This software can be used on a model with DVD-ROM&CD-R/RW drive and DVD Super Multi drive.

TOSHIBA Assist

TOSHIBA Assist is a graphical user interface that provides easy access to help and services. It is the default function launched by the TOSHIBA Assist button.

TOSHIBA PC Diagnostic Tool

TOSHIBA PC Diagnostic Tool displays the basic information on PC, and the test of built-in devices can also be performed. To start TOSHIBA PC Diagnostic Tool, click **start**, point to **All Programs**, point to **TOSHIBA**, point to **Utilities** and click **PC Diagnostic Tool**.

TOSHIBA Mobile Extension

This utility supports docking your computer to an optional Advanced Port Repricator III. To open the property dialog, select TOSHIBA Mobile Extension from TOSHIBA Assist.

TOSHIBA ConfigFree

TOSHIBA ConfigFree is a suite of utilities to allow easy control of communication devices and network connections. TOSHIBA ConfigFree also allows you to find communication problems and create profiles for easy switching between locations and communication networks. To start ConfigFree, click **start**, point to **All Programs**, point to **TOSHIBA**, point to **Networking** and click **ConfigFree**.

TOSHIBA TouchPad On/Off Utility

This utility has the following function. To disable/enable the Touch Pad with **Fn + F9** key.

TOSHIBA Password Utility

This utility lets you set a password that restricts access to the computer.

TOSHIBA Accessibility

This utility lets you make the **Fn** key sticky, that is, you can press it once, release it, and they press an “**F number**” key. The **Fn** key remains active until another key is pressed.

DLA for TOSHIBA

DLA (Drive Letter Access) is the packet writing software which provides the function which writes files and/or folders to DVD-RW, CD-RW and DVD+RW disc via a drive letter like a floppy disk or other removable disks.

TOSHIBA Hotkey Utility for Display Devices	This utility has the change of a display device, and the function to change display resolution. Press Fn + F5 to change the active display device. Press Fn + Space keys to change the display resolution.
TOSHIBA SD Memory Card Format	This utility has the function which formats SD memory card by SD standard format.
TOSHIBA Acoustic Silencer	This utility has the function to set up the speed (read) of CD/DVD drive. You can set up one of the modes: [Normal Mode] can read data early, and [Quiet Mode] can lessen noise.

Options

You can add a number of options to make your computer even more powerful and convenient to use. The following options are available:

Memory expansion	A 256, 512 or 1,024 MB memory module (DDR 333) can easily be installed in the computer.
Battery pack	An additional battery pack can be purchased from your TOSHIBA dealer. Use it as a spare or replacement.
High capacity battery pack	An additional battery pack can be purchased from your TOSHIBA dealer. Use it as a spare or replacement.
AC adaptor	If you use your computer at more than one site frequently, it may be convenient to purchase an additional AC adaptor for each site so you will not have to carry the adaptor with you.
Battery charger	The battery charger lets you charge extra batteries outside the computer.
Security lock	A slot is available to attach a security cable to the computer to deter theft.
USB floppy disk Kit	USB floppy disk drive accommodates 1.44-megabyte or 720-kilobyte floppy disk. It connects to a USB port. (You cannot format 720-kilobyte floppy disks on Windows XP, but you can use previously formatted disks.)

Advanced Port Replicator III

The Advanced Port Replicator III provides the ports available on the computer in addition to separate PS/2 mouse and PS/2 keyboard ports, a digital visual interface (DVI) port, i.LINK™ (IEEE 1394) port, line-in jack and line-out jack, External monitor port, Universal Serial Bus port (USB2.0) × 4, LAN jack, Modem jack, Serial port, Parallel port.



The PORTÉGÉ M300 does not support the DVI and i.LINK ports on the Advanced Port Replicator III.

Wireless LAN Kit

This option enables wireless LAN functions in computers that do not have wireless preinstalled. It is installed by dealers only.

Bluetooth Kit

This option enables Bluetooth wireless communications in computers that do not have Bluetooth preinstalled. It is installed by dealers only.

Bluetooth SD card3

Bluetooth SD card is an optional accessory compatible with the SD card slot of this computer. You can buy the card from a TOSHIBA dealer.

The Grand Tour

This chapter identifies the various components of your computer. Become familiar with each component before you operate the computer.



Certain notebook chassis are designed to accommodate all possible configurations for an entire product series. Your select model may not have all the features and specifications corresponding to all of the icons or switches shown on the notebook chassis, unless you have selected all those features.

Front with the display closed



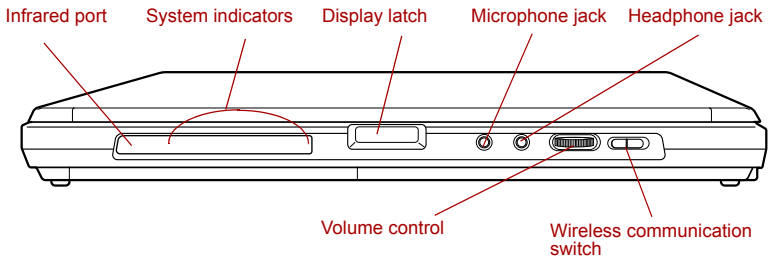

The following figure shows the computer's front with its LCD display panel in the closed position.



Front of the computer with LCD display panel closed



Infrared port	This infrared port is compatible with Infrared Data Association (IrDA 1.1) standards. It enables cableless 4 Mbps, 1.15 Mbps, 115.2 kbps, 57.6 kbps, 38.4 kbps, 19.2 kbps or 9.6 kbps data transfer with IrDA 1.1 compatible external devices.
System indicators	LEDs let you monitor the status of various computer functions. Details are given in the System indicators section.

	Display latch	This latch secures the LCD panel in its closed position. Push the latch to open the display.
	Microphone jack	A 3.5 mm mini microphone jack enables connection of a three-conductor mini jack for monaural microphone input.
	Headphone jack	A 3.5 mm mini headphone jack enables connection of stereo headphones.
	Volume control	Use this dial to adjust the volume of the stereo speakers and the stereo headphones.
	Wireless communication switch	Slide this switch to the left to turn off Wireless LAN and Bluetooth functions. Slide it to the right to turn on the functions.



Set the switch to off in airplanes and hospitals. Check the wireless communication indicator. It will stop glowing when the wireless communication function is off.

Left side

The following figure shows the computer's left side.

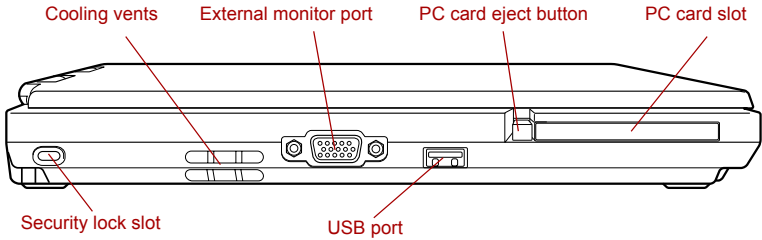









The left side of the computer

	Cooling vents	Cooling vents help CPU keep from overheating.
--	----------------------	-----------------------------------------------



Do not block the cooling vents. Do not insert or allow foreign objects to enter the cooling vents. If pins or similar objects are inserted into the computer, the computer's circuitry may be damaged.

	External monitor port	This external monitor port lets you connect an external video display.
	PC card slot	The PC card slot can accommodate a Type II card. The slot supports 16-bit PC cards and CardBus PC cards.
	PC card eject button	Press this button to eject a PC card from the PC card slot.
	<i>Keep foreign objects out of the PC card slot. A pin or similar object can damage the computer's circuitry.</i>	
	Security lock slot	A security cable attaches to this slot. The optional security cable anchors your computer to a desk or other large object to deter theft.
	Universal Serial Bus (USB 2.0) port	There is one Universal Serial Bus port on the left side. The port complies with the USB 2.0 standard, which enables data transfer speeds 40 times faster than the USB 1.1 standard (The ports also support USB 1.1).
	<i>Keep foreign objects out of the USB connectors. A pin or similar object can damage the computer's circuitry.</i>	
	<i>Operation of all functions of all USB devices has not been confirmed. Some functions might not execute properly.</i>	

Right side

The following figure shows the computer's right side.

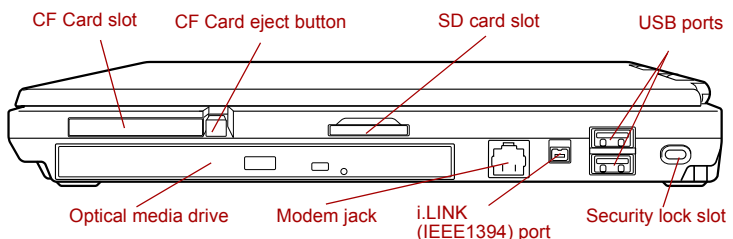

The right side of the computer



CF Card slot

This slot accommodates CompactFlash. You cannot use CompactFlash that does not conform to CompactFlash Association specifications.

CF card eject button

Press this button to eject a CompactFlash Card from the CF card slot.



Keep foreign objects out of the CF Card slot. A pin or similar object can damage the computer's circuitry.



SD card slot

SD cards are used in a wide variety of external devices. This slot lets you transfer data from the device to your computer.



Keep foreign objects out of the SD card slot. A pin or similar object can damage the computer's circuitry.



Universal Serial Bus (USB 2.0) ports

Two Universal Serial Bus ports are on the right side. Refer to [Left side](#) section, for details.

Optical media drive

This computer is configured with a DVD-ROM&CD-R/RW drive or a DVD Super Multi drive.



Modem jack

The modem jack lets you use a modular cable to connect the modem directly to a telephone line.



- *In case of a lightning storm, unplug the modular cable from the telephone jack.*
- *Do not connect the modem to a digital telephone line. A digital line will damage the modem.*



i.LINK (IEEE1394) port

Connect an external device, such as a digital video camera to this port for high-speed data transfer.



Security lock slot

A security cable attaches to this slot. The optional security cable anchors your computer to a desk or other large object to deter theft.

Backside

The following figure shows the computer's backside.

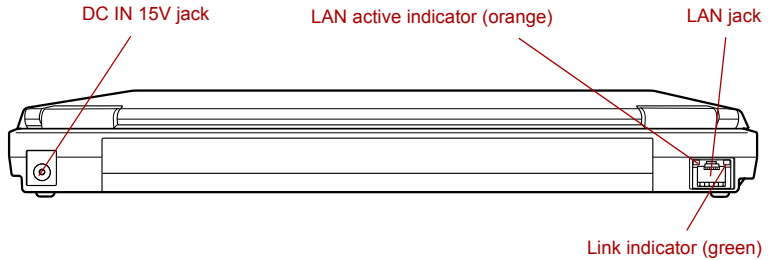

The backside of the computer



DC IN 15V jack

The AC adaptor connects to this jack. Use only the model of AC adaptor that comes with the computer. Using the wrong adaptor can damage your computer.



LAN jack

This jack lets you connect to a LAN. The adaptor has built-in support for Ethernet LAN (10 megabits per second, 10BASE-T) and Fast Ethernet LAN (100 megabits per second, 100BASE-TX). The LAN has two indicators. Refer to Chapter 4, [Operating Basics](#), for details.



- *Do not connect any cable other than a LAN cable to the LAN jack. It could cause damage or malfunction.*
- *Do not connect the LAN cable to a power supply. It could cause damage or malfunction.*

Link indicator (green)

This indicator glows green when the computer is connected to a LAN and the LAN is functioning properly.

LAN active indicator (orange)

This indicator glows orange when data is being exchanged between the computer and the LAN.

Underside

The following figure shows the underside of the computer. Make sure the display is closed before turning over your computer.

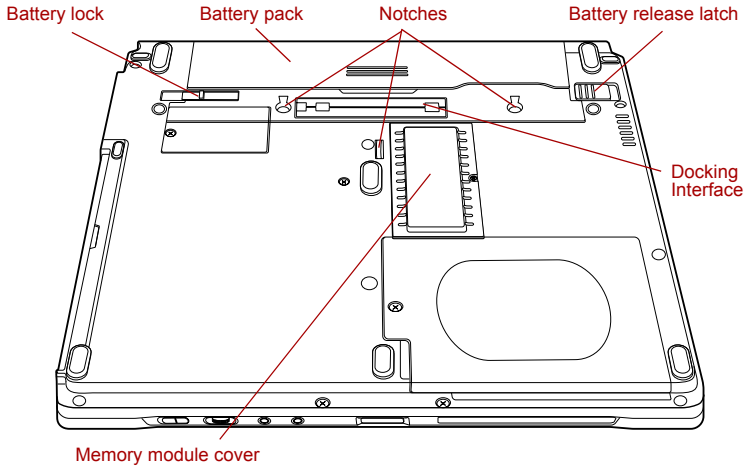

The underside of the computer

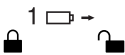

1

Battery lock

Slide this lock to release the battery pack for removal.

Battery pack

The battery pack powers the computer when the AC adaptor is not connected. For detailed information on the battery pack, refer to Chapter 6, [Power and Power-Up Modes](#).

Notches

Notches on the computer engage hooks on the Advanced Port Replicator III to hold the connection securely.

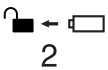

2

Battery release latch

Slide and hold this latch to release the battery pack for removal. For detailed information on removing the battery packs, refer to Chapter 6, [Power and Power-Up Modes](#).



Docking interface

This port enables connection of an optional Advanced Port Replicator III described in Chapter 8, [Optional Devices](#).



Keep foreign objects out of the docking interface port. A pin or similar object can damage the computer's circuitry. A plastic shutter protects the connector.



Memory module cover



This cover protects one memory module socket one or no module is preinstalled. Refer to the [Memory expansion](#) section in Chapter 8, [Optional Devices](#) .

Front with the display open

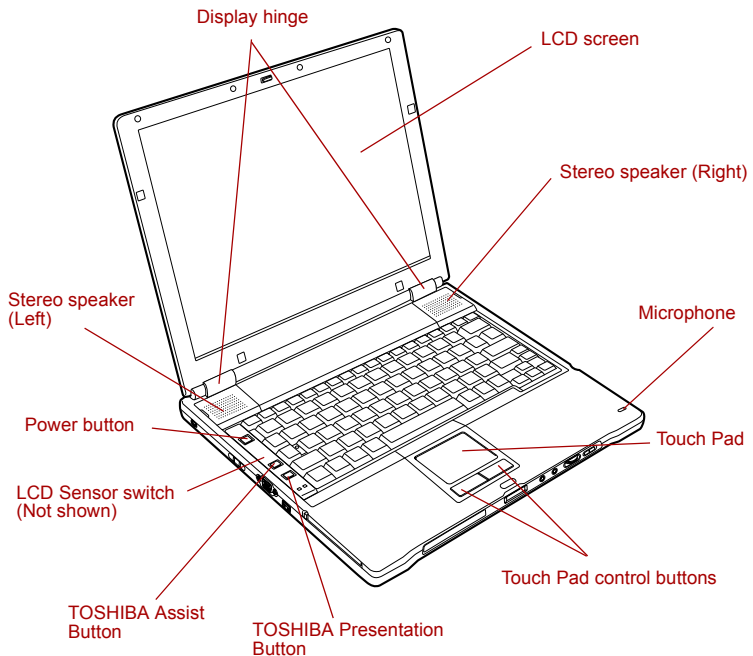
This section shows the computer with the LCD display panel open. Refer to the appropriate illustration for details. To open the display, push the display latch on the front of the LCD display panel and lift up. Position the LCD display panel at a comfortable viewing angle.



The front of the computer with the LCD panel open

Display hinge	The display hinge holds the LCD display panel at easy-to-view angles.
LCD screen	<p>The LCD screen displays high-contrast text and graphics. The computer's XGA screen consists of 1024 × 768 pixels. Refer to Display Controller and Modes in Appendix B .</p> <p>When the computer operates on the AC adaptor the LCD screen's image will be somewhat brighter than when it operates on battery power. The lower brightness level is intended to save battery power.</p>
LCD Sensor switch	<p>This switch senses when the computer's LCD display panel is closed or opened and activates the Panel Power Off/On feature. When you close the LCD display panel the computer enters Hibernation mode and shuts down. When you open the computer's LCD display panel the computer starts in Hibernation mode. Use the TOSHIBA Power Saver Utility to enable or disable this feature. The default is "enabled".</p> <p>Refer to the TOSHIBA Power Saver and Panel Power Off/On items in Chapter 1, Special features, for details on settings.</p>
	<p><i>Do not put a magnetic object close to the switch. The computer will automatically enter Hibernation mode and shut down even if the Panel Power Off features is disabled.</i></p>
Stereo speakers	The speakers emit sound generated by your software as well as audio alarms, such as low battery condition, generated by the system.
Touch Pad	A Touch Pad located in the center of the palm rest is used to control the on-screen pointer. Refer to the Using the Touch Pad section in Chapter 4, Operating Basics.
Touch Pad control buttons	Control buttons below the Touch Pad let you select menu items or manipulate text and graphics designated by the on-screen pointer.
Microphone	A built-in microphone lets you record sound into your applications. Refer to the Microphone level section in Chapter 4, Operating Basics.
 Power button	Press the power button to turn the computer's power on and off.



**TOSHIBA
Presentation button**

Press this button to change internal display, simultaneous display, or multi-monitor display. The default setting is the simultaneous display on LCD and CRT with resolution of 1024 × 768. When you press this button twice, the display mode returns to single display on LCD only. Setting of multi-monitor display in Windows XP, computer changes its display mode to the multi-monitor display on LCD and CRT. You can also return to single display by pressing this button twice.

The setting of TOSHIBA Presentation button can be changed through the properties of TOSHIBA Controls. Display mode is changed to the multi-monitor display by selecting "Different Image" (Windows XP only) or to the simultaneous display on internal and external display by selecting "Same Image".



**TOSHIBA Assist
button**

Press this button to launch an application automatically.

If the computer is off, pressing this button starts the computer and launches the associated program automatically.

The default is TOSHIBA Assist.

System indicators

LEDs beneath icons, light when various computer operations are in progress.



DC IN



Power



Battery



HDD



Wireless communication



SD card

System indicators



DC IN

The **DC IN** indicator glows in green when DC power is supplied from the AC power adaptor. If the adaptor's output voltage is abnormal or if the power supply malfunctions, this indicator flashes orange.



Power

The **Power** indicator glows in green when the computer is on. If you select **Standby** from **Shut Down Windows**, this indicator blinking orange (one second on, two seconds off) while the computer shuts down.



Battery

The **Battery** indicator shows the condition of the battery's charge: Green indicates full charge, orange indicates battery charging and flashing orange indicates a low battery charge. Refer to Chapter 6, [Power and Power-Up Modes](#).



HDD

The **HDD** indicator glows green when the computer is accessing the built-in hard disk.



Wireless communication

The **Wireless communication** indicator glows when the Bluetooth and wireless LAN functions are turned on.

Some models are equipped with Wireless communication features.



SD card

The **SD card** indicator glows green when the computer is accessing the SD card slot.

Keyboard indicators

The figures below show the positions of the keypad overlay indicators and the Caps Lock indicator.

When the Arrow mode indicator glows the keypad overlay lets you control the cursor.

When the Numeric mode indicator glows the keypad overlay lets you enter numbers.

When the Caps Lock indicator glows the keyboard is in all-caps mode.

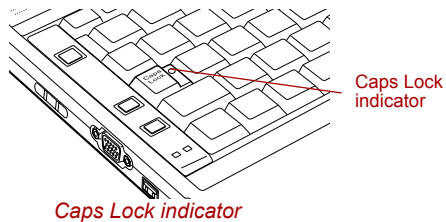

Caps Lock

This indicator glows green when the alphabet keys are locked in uppercase.

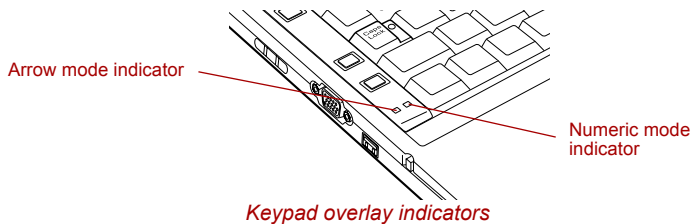

Arrow mode

When the **Arrow mode** indicator lights green, you can use the keypad overlay (gray labeled keys) as cursor keys. Refer to the [Keypad overlay](#) section in Chapter 5, The Keyboard .



Numeric mode

You can use the keypad overlay (gray labeled keys) for numeric input when the **Numeric mode** indicator lights green. Refer to the [Keypad overlay](#) section in Chapter 5, The Keyboard .

USB floppy disk drive (optional)

The optional USB floppy disk drive accommodates 1.44-megabyte or 720-kilobyte floppy disks.

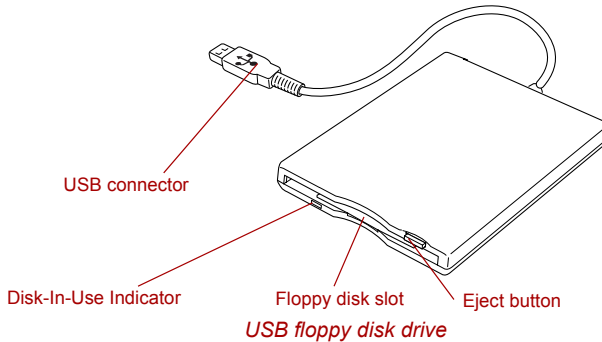

USB connector	Insert this connector to the USB port of your computer.
Disk-In-Use Indicator	This indicator lights when the floppy disk is being accessed.
Floppy disk slot	Insert a floppy disk in this slot.
Eject button	When a floppy disk is fully seated in the drive, the eject button pops out. To remove a floppy disk, push in the eject button and the floppy disk pops out partially for removal.



Check the **Disk-In-Use** indicator when you use the USB floppy disk drive. Do not press the eject button or turn off the computer while the light is glowing. Doing so could destroy data and damage the floppy disk or the drive.



- The USB floppy disk drive should be placed on a flat, horizontal surface when in use. Do not set the drive on an incline greater than 20° while it is operating.
- Do not set anything on top of the floppy disk drive.

Optical media drives

One of the following optical media drives is installed in the computer: DVD-ROM&CD-R/RW drive or DVD Super Multi drive. An ATAPI interface controller is used for CD/DVD-ROM operation. When the computer is accessing a CD/DVD, an indicator on the drive glows.

For information on loading and unloading discs refer to the [Using optical media drives](#) section in Chapter 4, Operating Basics.

Region codes for DVD drives and media

DVD-ROM&CD-R/RW and DVD Super Multi drives and media are manufactured according to the specifications of six marketing regions. When you purchase DVD-Video, make sure it matches your drive, otherwise it will not play properly.

Code	Region
1	Canada, United States
2	Japan, Europe, South Africa, Middle East
3	Southeast Asia, East Asia
4	Australia, New Zealand, Pacific Islands, Central America, South America, Caribbean
5	Russia, Indian Subcontinent, Africa, North Korea, Mongolia
6	China

Writable discs

This section describes the types of writable CD/DVD discs. Check the specifications for your drive to for the type of discs it can write. Use RecordNow! to write compact discs. Refer to Chapter 4, [Operating Basics](#).

CDs

- CD-R discs can be written only once. The recorded data cannot be erased or changed.
- CD-RW discs can be recorded more than once. Use either 1, 2, or 4 multi speed CD-RW discs or high-speed 4- to 10-speed discs. The write speed of the ultra-speed CD-RW discs is maximum 24-speed.

DVDs

- DVD-R and DVD+R discs can be written only once. The recorded data cannot be erased or changed.
- DVD-RW, DVD+RW and DVD-RAM discs can be recorded more than once.

Formats

The drives support the following formats:

- CD-ROM
- DVD-ROM
- CD-DA
- Photo CD™ (single/multi-session)
- CD-ROM XA Mode 2 (Form1, Form2)
- DVD -Video
- CD-Text
- CD-ROM Mode 1, Mode 2
- Enhanced CD (CD-EXTRA)
- Addressing Method 2

DVD-ROM&CD-R/RW drive

The full-size DVD-ROM&CD-R/RW drive module lets you record data to rewritable CDs as well as run either 12 cm (4.72") or 8 cm (3.15") CD/DVDs without using an adaptor.



The read speed is slower at the center of a disc and faster at the outer edge.

DVD read	8 speed (maximum)
CD read	24 speed (maximum)
CD-R write	24 speed (maximum)
CD-RW write	24 speed (maximum, high-speed media)

DVD Super Multi drive



The read speed is slower at the center of a disc and faster at the outer edge.

DVD read	8 speed (maximum)
DVD-R write	2 speed (maximum)
DVD-RW write	2 speed (maximum)
DVD+R write	2.4 speed (maximum)
DVD+RW write	2.4 speed (maximum)
DVD-RAM write	2 speed (maximum)
CD read	24 speed (maximum)
CD-R write	24 speed (maximum)
CD-RW write	10 speed (maximum, Ultra-speed media)

AC adaptor

The AC adaptor converts AC power to DC power and reduces the voltage supplied to the computer. It can automatically adjust to any voltage from 100 to 240 volts and to a frequency of either 50 or 60 hertz, enabling you to use the computer in almost any country/region.

To recharge the battery, simply connect the AC adaptor to a power source and the computer. Refer to Chapter 6, [Power and Power-Up Modes](#), for details.

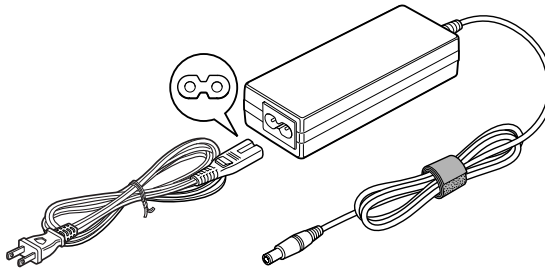

The AC adaptor (2-pin plug)

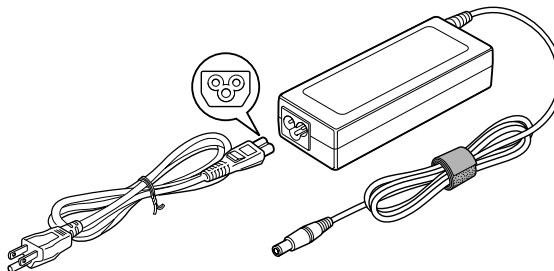

The AC adaptor (3-pin plug)



The Universal AC Adaptor and power cord bundled with this product may differ depending on the product model. Depending on the model, a 2-pin plug or 3-pin plug set of the above may be bundled.

Do not use a 3-pin to 2-pin conversion plug.

The supplied power cord conforms to safety rules and regulations in the region the product is bought and should not be used outside this region. For use in other regions, please buy power cords that conform to safety rules and regulations in the particular region.



Use only the AC adaptor that came with the computer or an equivalent optional adaptor. Use of any other adaptors could damage your computer. TOSHIBA assumes no liability for any damage in such case.



Use only the AC adaptor supplied as an accessory. Other AC adaptors have different voltage and terminal polarities and use of them may produce heat and smoke or even result in fire or rupture.

Getting Started

This chapter provides basic information to get you started using your computer. It covers the following topics:

- Setting up your work space — for your health and safety



Be sure also to read the Safety Instruction Manual. This guide, which is included with the computer, explains product liability.

- Connecting the AC adaptor
- Opening the display
- Turning on the power
- Starting up for the first time
- Turning off the power
- Restarting the computer
- Restoring the preinstalled software



All users should be sure to read the section [Starting up for the first time](#).

Setting up your work space

Establishing a comfortable work site is important for you and your computer. A poor work environment or stressful work habits can result in discomfort or serious injury from repetitive strain to your hands, wrists or other joints. Proper ambient conditions should also be maintained for the computer's operation. This section discusses the following topics:

- General conditions
- Placement of the computer
- Seating and posture
- Lighting
- Work habits

General conditions

In general, if you are comfortable, so is your computer, but read the following to make sure your work site provides a proper environment.

- Make sure there is adequate space around the computer for proper ventilation.
- Make sure the AC power cord connects to an outlet that is close to the computer and easily accessible.
- The temperature should be 5 to 35 degrees Centigrade (41 to 95 degrees Fahrenheit) and the relative humidity should be 20 to 80 percent.
- Avoid areas where rapid or extreme changes in temperature or humidity may occur.
- Keep the computer free of dust, moisture, and exposure to direct sunlight.
- Keep the computer away from heat sources, such as electric heaters.
- Do not use the computer near liquids or corrosive chemicals.
- Do not place the computer near objects that create strong magnetic fields (e.g., stereo speakers).
- Some computers in the computer, including data storage media, can be damaged by magnets. Do not place the computer near magnetic objects or bring magnetic objects close to the computer. Be careful of objects, such as stereo speakers, that produce strong magnetic fields during operation. Also, be careful with metal objects, such as bracelets, which can be inadvertently magnetized.
- Do not operate the computer in close proximity to a mobile phone.
- Leave ample ventilation room for the fan. Do not block the vents.

Placement of the computer

Position the computer and peripheral devices to provide comfort and safety.

- Set the computer on a flat surface at a comfortable height and distance. The LCD display panel should be no higher than eye level to avoid eyestrain.
- Place the computer so that it is directly in front of you when you work and make sure you have adequate space to easily operate other devices.
- Allow adequate space behind the computer to let you freely adjust the LCD display panel. The LCD display panel should be angled to reduce glare and maximize visibility.
- If you use a paper holder, set it at about the same height and distance as the computer.

Seating and posture

The height of your chair in relation to the computer and keyboard as well as the support it gives your body are primary factors in reducing work strain. Refer to the following tips.

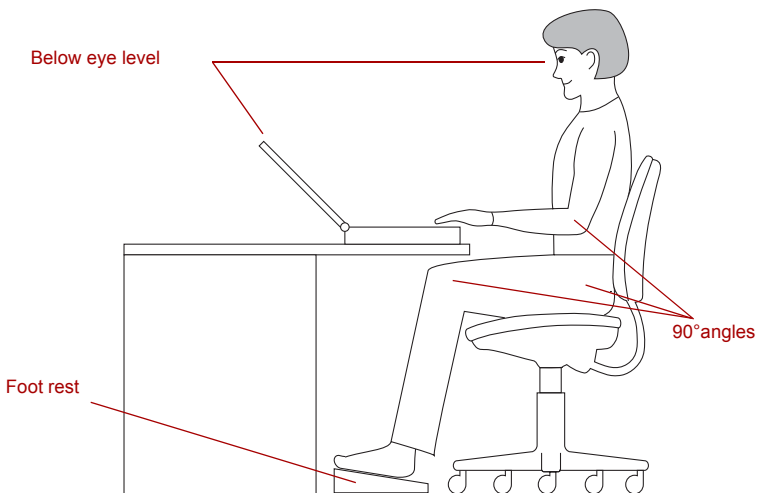

Posture and positioning of the computer

- Place your chair so that the keyboard is at or slightly below the level of your elbow. You should be able to type comfortably with your shoulders relaxed.
- Your knees should be slightly higher than your hips. If necessary, use a foot rest to raise the level of your knees to ease pressure on the back of your thighs.
- Adjust the back of your chair so it supports the lower curve of your spine.
- Sit straight so that your knees, hips and elbows form approximately 90 degree angles when you work. Do not slump forward or lean back too far.

Lighting

Proper lighting can improve legibility of the LCD screen and reduce eyestrain.

- Position the computer so that sunlight or bright indoor lighting does not reflect off the LCD screen. Use tinted windows, shades or other screen to eliminate sun glare.
- Avoid placing the computer in front of bright light that could shine directly in your eyes.
- If possible, use soft, indirect lighting in your computer work area. Use a lamp to illuminate your documents or desk, but be sure to position the lamp so that it does not reflect off the LCD screen or shine in your eyes.

Work habits

A key to avoiding discomfort or injury from repetitive strain is to vary your activities. If possible, schedule a variety of tasks into your workday. If you must spend long periods at the computer, finding ways to break up the routine can reduce stress and improve your efficiency.

- Sit in a relaxed posture. Good positioning of your chair and equipment as described earlier can reduce tension in your shoulders or neck and ease back strain.
- Vary your posture frequently.
- Occasionally stand up and stretch or exercise briefly.
- Exercise and stretch your wrists and hands a number of times during the day.
- Frequently, look away from the computer and focus your eyes on a distant object for several seconds, for example 30 seconds every 15 minutes.
- Take frequent short breaks instead of one or two long breaks, for example, two or three minutes every half hour.
- Have your eyes examined regularly and visit a doctor promptly, if you suspect you might be suffering from a repetitive strain injury.

A number of books are available on ergonomics and repetitive strain injury or repetitive stress syndrome. For more information on these topics or for pointers on exercises for such stress points as hands and wrists, please check with your library or book vendor. Also refer to the computer's *Safety Instruction Manual*.

Connecting the AC adaptor

Attach the AC adaptor when you need to charge the battery or you want to operate from AC power. It is also the fastest way to get started, because the battery pack will need to be charged before you can operate from battery power.

The AC adaptor can be connected to any power source supplying from 100 to 240 volts and 50 or 60 hertz. For details on using the AC adaptor to charge the battery pack, refer to Chapter 6, [Power and Power-Up Modes](#).



Use only the AC adaptor supplied as an accessory. Other AC adaptors have different voltage and terminal polarities and use of them may produce heat and smoke or even result in fire or rupture.



- Use only the AC adaptor that came with the computer or an equivalent optional adaptor. Use of any other adaptors could damage your computer. TOSHIBA assumes no liability for any damage in such case.
- Do not use a 3-pin to 2-pin conversion plug.
- The supplied power cord conforms to safety rules and regulations in the region the product is bought and should not be used outside this region. For use in other regions, please buy power cords that conform to safety rules and regulations in the particular region.
- When you connect the AC adaptor to the computer, always follow the steps in the exact order as described in the User's Manual. Connecting the power cable to a live electrical outlet should be the last step otherwise the adaptor DC output plug could hold an electrical charge and cause an electrical shock or minor bodily injury when touched. As a general safety precaution, avoid touching any metal parts.

1. Connect the power cord to the AC adaptor.

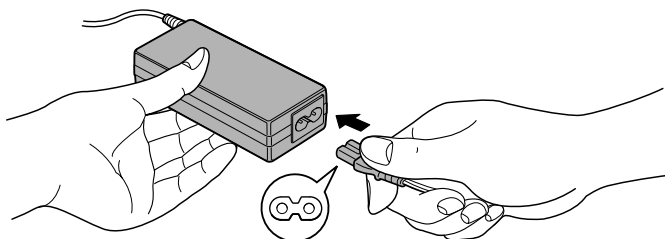

Connecting the power cord to the AC adaptor (2-pin plug)

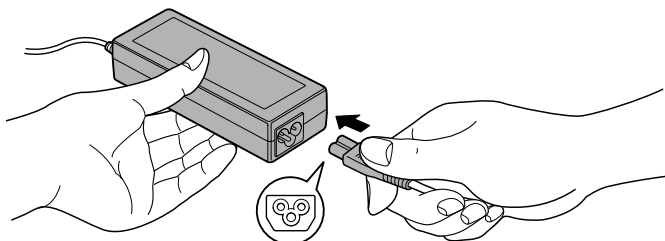

Connecting the power cord to the AC adaptor (3-pin plug)



The Universal AC Adaptor and power cord bundled with this product may differ depending on the product model. Depending on the model, a 2-pin plug or 3-pin plug set of the above may be bundled.

2. Connect the AC adaptor's DC output plug to the DC IN 15V jack on the back of the computer.

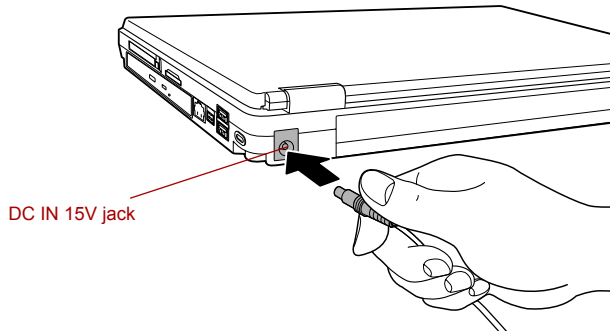

Connecting the adaptor to the computer

3. Plug the power cord into a live wall outlet. The **Battery** and **DC IN** indicators on the front of the computer should glow.

Opening the display

The computer's LCD display panel can be rotated in a wide range of angles for optimal viewing.

1. Push the display latch on the front of the computer to unlatch the display panel.
2. While holding down the palm rest with one hand so that the main body is not raised, lift the panel slowly. Adjust the angle of the panel to provide optimal clarity.



Use reasonable care when opening and closing the LCD display panel. Opening it vigorously or slamming it shut could damage the computer.

LCD display panel

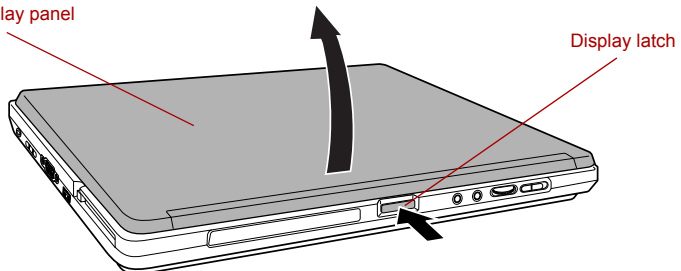

Opening the LCD display panel

Turning on the power

This section describes how to turn on the power.

The Power button LED indicates the status. Refer to the [Power indicator](#) section in Chapter 6, Power and Power-Up Modes .



- *After you turn on the power for the first time, do not turn it off until you have set up the operating system. Refer to the section [Starting up for the first time](#).*
- *If the USB floppy disk drive is connected, make sure it is empty. If a floppy disk is in the drive, press the eject button and remove the floppy disk.*

1. Open the computer's LCD display panel.
2. Press and hold the computer's power button for two or three seconds.

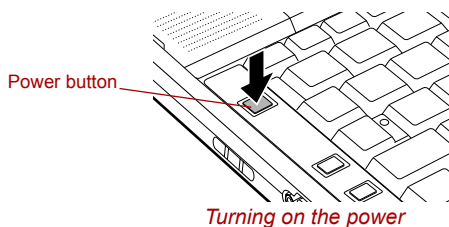

Starting up for the first time

When you first turn on the power, the computer's initial screen is the Microsoft Windows XP Startup Screen Logo. Follow the on-screen directions for each screen. During setup, you can click the **Back** button to return to the previous screen.

Be sure to read the **Windows End User License Agreement** display carefully.



Be sure to read the License Agreement carefully.

Turning off the power

The power can be turned off in one of the following modes: Shut down (Boot), Hibernation or Standby mode.

Shut Down mode (Boot mode)

When you turn off the power in Shut Down mode no data is saved and the computer will boot to the operating system's main screen.

1. If you have entered data, save it to the hard disk or to a floppy disk.
2. Make sure all disk (disc) activity has stopped, then remove the CD/DVDs or floppy disk.



Make sure the HDD indicator is off. If you turn off the power while a disk (disc) is being accessed, you can lose data or damage the disk (disc).

3. Click **start** then click **Turn Off Computer**. From the **Turn Off Computer** menu select **Turn Off**.
4. Turn off the power to any peripheral devices.



Do not turn the computer or devices back on immediately. Wait a moment to let all capacitors fully discharge.

Hibernation mode

The hibernation feature saves the contents of memory to the hard disk when the computer is turned off. The next time the computer is turned on, the previous state is restored. The hibernation feature does not save the status of peripheral devices.



- *Save your data. While entering hibernation mode, the computer saves the contents of memory to the HDD. However, for safety sake, it is best to save your data manually.*
- *Data will be lost if you remove the battery or disconnect the AC adaptor before the save is completed. Wait for the **HDD** indicator to go out.*
- *Do not install or remove a memory module while the computer is in hibernation mode. Data will be lost.*

Benefits of hibernation

The hibernation feature provides the following benefits:

- Saves data to the hard disk when the computer automatically shuts down because of a low battery.



For the computer to shut down in hibernation mode, the hibernation feature must be enabled in two places: the **Hibernate** tab in **Power Options** and **Setup Action** tab in **TOSHIBA Power Saver**.

Otherwise, the computer will shut down in **Standby** mode. If battery power becomes depleted, data saved in **Standby** mode will be lost.

- You can return to your previous working environment immediately when you turn on the computer.
- Saves power by shutting down the system when the computer receives no input or hardware access for the duration set by the System hibernate feature.
- You can use the panel power off feature.

Starting Hibernation



You can also enable Hibernation by pressing **Fn + F4**. Refer to [Chapter 5, The Keyboard](#), for details.

To enter Hibernation mode, follow the steps below.

1. Click **start**.
2. Select **Turn Off Computer**.
3. Open the **Turn Off Computer** dialog box. **Hibernate** is not displayed.
4. Press the **Shift** key. The **Standby** item will change to **Hibernate**.
5. Select the **Hibernate**.

Automatic Hibernation

The computer will enter Hibernation mode automatically when you press the power button or close the lid. First, however, make the appropriate settings according to the steps below.

1. Click **start** and open the **Control Panel**.
2. Open **Performance and Maintenance** and open **Power Options**.
3. Select the **Hibernate** window in the **Power Options Properties**, select the **Enable hibernation** check box and click the **Apply** button.
4. Open **TOSHIBA Power Saver**.
5. Select the **Setup Action** window.
6. Enable the desired Hibernation settings for **When I press the power button** and **When I close the lid**.
7. Click the **OK** button.

Data save in hibernation mode

When you turn off the power in hibernation mode, the computer takes a moment to save current memory data to the hard disk. During this time, the **HDD** indicator will light.

After you turn off the computer and memory is saved to the hard disk, turn off the power to any peripheral devices.



Do not turn the computer or devices back on immediately. Wait a moment to let all capacitors fully discharge.

Standby mode

If you have to interrupt your work, you can turn off the power without exiting from your software. Data is maintained in the computer's main memory. When you turn on the power again, you can continue working right where you left off.



- *When the AC adaptor is connected, the computer will go into Standby mode according to the settings in the TOSHIBA Power Saver utility.*
- *To restore operation from Standby mode, press the power button or press any key. The latter action works only if Wake-up on Keyboard is enabled in HW Setup.*
- *If the computer automatically enters Standby mode while a network application is active, the application might not be restored when the computer wakes up from Standby.*
- *To prevent the computer from automatically entering Standby mode, disable Standby in TOSHIBA Power Saver. That action, however, will nullify the computer's Energy Star compliance.*



- *Before entering Standby mode, be sure to save your data.*
- *Do not install or remove a memory module while the computer is in standby mode. The computer or the module could be damaged.*
- *Do not remove the battery pack while the computer is in standby mode (unless the computer is connected to an AC power source). Data in memory will be lost.*
- *If you carry the computer on board an aircraft or into a hospital, be sure to shut down the computer in hibernation mode or in shutdown mode to avoid radio signal interference.*

Benefits of standby

The standby feature provides the following benefits:

- Restores the previous working environment more rapidly than does hibernation.
- Saves power by shutting down the system when the computer receives no input or hardware access for the duration set by the System Standby feature.
- You can use the panel power off feature.

Executing standby



You can also enable Standby by pressing **Fn + F3**. See Chapter 5, [The Keyboard](#), for details.

You can enter standby mode in one of three ways:

1. Click **start**, click **Turn Off Computer** and click **Stand By**.
2. Close the computer's LCD display panel. This feature must be enabled. Refer to the *Setup Action* tab in *TOSHIBA Power Saver Utility* described in the Control Panel.
Open **Performance and Maintenance** and open **TOSHIBA Power Saver**.
3. Press the power button. This feature must be enabled. Refer to the *Setup Action* tab in *TOSHIBA Power Saver Utility* described in the Control Panel.
Open **Performance and Maintenance** and open **TOSHIBA Power Saver**.

When you turn the power back on, you can continue where you left when you shut down the computer.



- *When the computer is shut down in standby mode, the power indicator blinking orange.*
- *If you are operating the computer on battery power, you can lengthen the operating time by shutting down in hibernation mode. Standby mode consumes more power.*

Standby limitations

Standby will not function under the following conditions:

- Power is turned back on immediately after shutting down.
- Memory circuits are exposed to static electricity or electrical noise.

Restarting the computer

Certain conditions require that you reset the system. For example, if:

- You change certain computer settings.
- An error occurs and the computer does not respond to your keyboard commands.

There are three ways to reset the computer system:

1. Click **start** then click **Turn off computer**. From the **Turn off computer** menu select **Restart**.
2. Press **Ctrl + Alt + Del** to display the **Windows Task Manager**, then select **Shut Down** and **Restart**.
3. Press the power button and hold it down for five seconds. Wait 10 to 15 seconds, then turn the power on again by pressing the power button.

Restoring the preinstalled software



Some models in this series are prepared for Hard Disk Recovery. These models will come without a Product Recovery optical media and a Tools & Utilities CD-ROM. You can restore the preinstalled software depending on the model you purchased.

Restoring from Recovery HDD



For models only with HDD Recovery installed.

If preinstalled files are damaged, use the HDD Recovery installation to restore them.



When you reinstall the Windows operating system, the hard disk will be reformatted and all data will be lost. Make sure you have a backup copy of your data, before you perform a complete system recovery.

Creating Optical Recovery Discs

A recovery image of your computer is stored on the hard disk. You may use this image to create CD or DVD recovery discs using the following steps:

1. Select either blank CDs or DVD media.
2. The application will allow you to choose a type of media to create recovery CDs/DVD including: CD-R, CD-RW, DVD-R, DVD-RW, DVD+R and DVD+RW.



Some media may not be compatible with the Optical Drive of your computer. Please verify your Optical Drive supports the blank media you choose.

3. Turn on your computer to open Windows XP.
4. Insert the (first) blank media into the tray of the Optical Drive.
5. Double click the Recovery Disc Creator Launcher icon on the Windows XP desktop, or Select the application from **start** Menu.
6. After Recovery Disc Creator starts, select the type of media and the title you wish to copy to the media then click the **Burn** button.



If your Optical Drive can only write to CDs, select "CD" as the "Type" on Recovery Disc Creator. If your Optical Drive of your computer can write to either CD or DVDs, select the one you are using as the "Type" on Recovery Disc Creator.

Restoring from the Recovery HDD

About 2GB of hard disk space is reserved for recovery partition.

When re-setting up your hard disk, do not change, delete or add partitions in a manner other than specified in the manual. Otherwise, space for software may be destroyed.

In addition, if you use a third-party partitioning program to reconfigure partitions on your hard disk, it may become impossible to re-setup your computer.

1. Turn off your computer.
2. While holding down **0** (zero) key on the keyboard, turn on your computer.
3. A menu appears. Press the "**1**" key on the keyboard to restore the original configuration as purchased. Press the "**2**" key to keep your current partitions intact and restore. Press the "**3**" key to specify partitions and restore.
4. Follow the on-screen instructions.

Restoring from your created Recovery Media

If preinstalled files are damaged, use your created Recovery Media to restore them. To restore the operating system and all preinstalled software, follow the steps below.



When you reinstall the Windows operating system, the hard disk will be reformatted and all data will be lost.

1. Load the Recovery Media in the optional optical media drive and turn off the computer's power.
2. Hold down the **F12** key and turn on the power. When In Touch with Tomorrow TOSHIBA appears, release the **F12** key.
3. Use the left or right cursor key to select the CD-ROM icon in the display menu. For details, refer to the [Boot Priority](#) section in Chapter 7, HW Setup .
4. A menu appears. Press the "**1**" key on the keyboard to restore all hard disk. Press the "**2**" key to Restore drive **C:**. Press the "**3**" key to Restore Recovery tool.
5. Follow the on-screen instructions.

Restoring from the Product Recovery Media



For models only with bundled Product Recovery optical media.

If preinstalled files are damaged, use the Product Recovery DVD or the TOSHIBA Tools & Utilities CD-ROM to restore them.

Restoring the complete system

To restore the operating system and all preinstalled software, follow the steps below.



When you reinstall the Windows operating system, the hard disk will be reformatted and all data will be lost. Make sure you have a backup copy of your data, before you perform a complete system recovery.

1. Load the Product Recovery disk in the optical media drive and turn off the computer's power.
2. Hold down the **F12** key and turn on the power. When **In Touch with Tomorrow TOSHIBA** appears, release the **F12** key.
3. Use the left or right cursor key to select the CD-ROM/DVD-ROM icon in the display menu. For details, refer to the [Boot Priority](#) section in Chapter 7, HW Setup .
4. Follow the on-screen instructions.
5. If your computer came with additional software installed, this software can not be recovered from the Product Recovery disk. Re-install these applications (e.g. Works Suite, DVD Player, Games, etc.) separately from other media.

Restoring TOSHIBA utilities and drivers

If Windows is working properly, individual drivers or applications can be separately restored. The Toshiba Tools & Utilities CD-ROM contains drivers and applications which were included with your computer system. If your system drivers or applications have become damaged in some way, this CD allows you to reinstall most of the components which are not part of the Windows operating system.

Chapter 4

Operating Basics

This chapter gives information on basic operations including using the Touch Pad, the USB floppy disk drive (optional), optical media drives, Sound System, Modem, Wireless communication features and LAN. It also provides tips on care of the computer, floppy disks and CD/DVDs.

Using the Touch Pad

To use the Touch Pad, simply touch and move your fingertip across it in the direction you want the on-screen pointer to go.

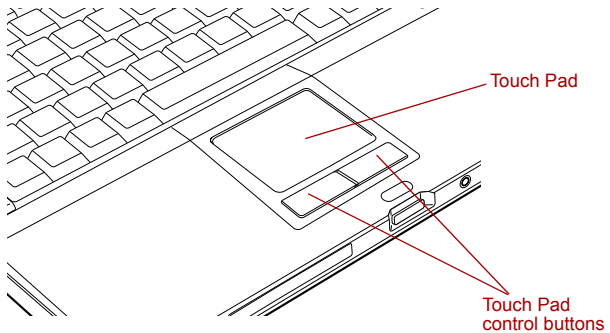

Touch Pad and Touch Pad control buttons

Two buttons below the Touch Pad are used like the buttons on a mouse pointer. Press the left button to select a menu item or to manipulate text or graphics designated by the pointer. Press the right button to display a menu or other function depending on the software you are using.



You can also tap the Touch Pad to perform functions similar to those of the left button.

Click: Tap once

Double-click: Tap twice

Drag and drop: Tap to select the material you want to move. Leave your finger on the Touch Pad after the second tap and move the material.

Using the USB floppy disk drive

USB floppy disk drive connects to one of the computer's USB ports. It accommodates 1.44-megabyte or 720-kilobyte floppy disks. Refer to Chapter 2, *The Grand Tour*, for more information.

Connecting USB floppy disk drive

To connect the drive, plug the floppy disk drive's USB connector into a computer's USB port.



Make sure the connector is right side up and properly aligned with the socket. Do not try to force the connection, doing so can damage the connecting pins.

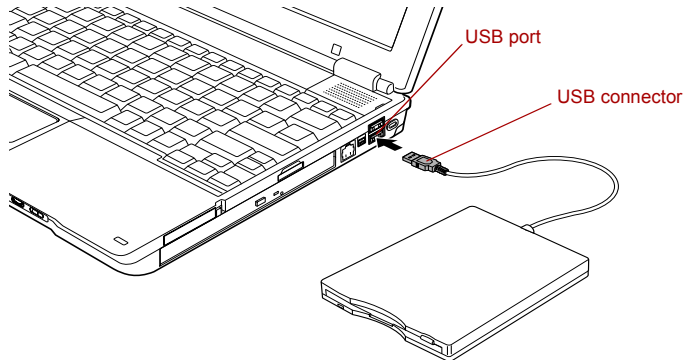

Connecting the USB floppy disk drive



If you connect the USB floppy disk drive after turning on the computer, it will take about 10 seconds for the computer to recognize the drive. Do not disconnect and reconnect before 10 seconds has elapsed.

Disconnecting USB floppy disk drive

When you have finished using the USB floppy disk drive, follow the procedures below to disconnect it:

1. Wait for the indicator light to go out to make sure all floppy disk activity has stopped.



If you disconnect the USB floppy disk drive or turn off the power while the computer is accessing the drive you may lose data or damage the floppy disk or the drive.

2. Click the **Safely Remove Hardware** icon on the Task Bar.
3. Click **USB floppy disk drive** that you want remove.
4. Pull the USB floppy disk drive's USB connector out of the computer's USB port.

Using optical media drives

The full-size drive provides high-performance execution of CD/DVD-ROM-based programs. You can run either 12 cm (4.72") or 8 cm (3.15") CD/DVDs without an adaptor. An ATAPI interface controller is used for CD/DVD-ROM operation. When the computer is accessing a CD/DVD-ROM, an indicator on the drive glows.



Use the WinDVD application to view DVD-Video discs.

If you have a DVD-ROM&CD-R/RW drive, refer also to the [Writing CDs on DVD-ROM&CD-R/RW drive](#) section for precautions on writing to CDs.

If you have a DVD Super Multi drive, refer also to the [Writing CD/DVDs on DVD Super Multi drive](#) section for precautions on writing to CDs.



*When the power of the optical media drive is off, pressing the **Fn + Tab** keys will turn the power of the optical media drive on. Furthermore, it is possible to set it to turn the power of the optical media drive on and eject the tray at the same time.*

Loading discs

To load CD/DVDs, follow the steps below.

1. When the computer's power is on, press the eject button to open the disc tray slightly.

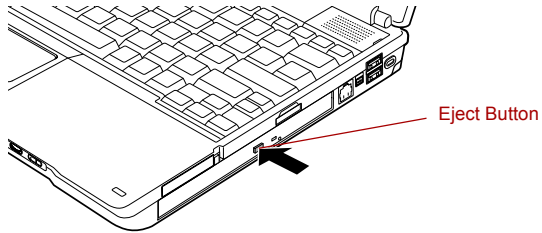

Pressing the eject button

2. Grasp the disc tray gently and pull until it is fully opened.

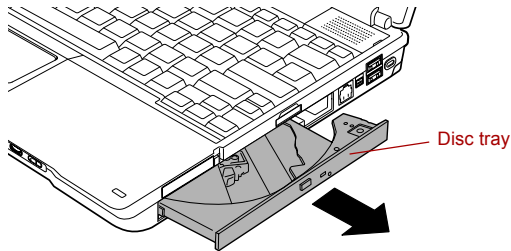

Pulling the disc tray open

3. Lay the CD/DVD, label side up, in the disc tray.

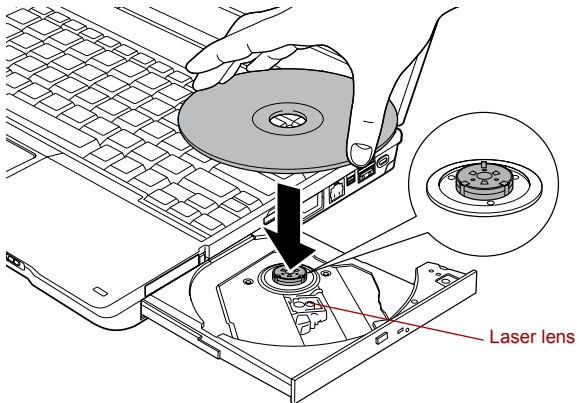

Inserting a CD/DVD



When the disc tray is fully opened, the edge of the computer will extend slightly over the CD/DVD tray. Therefore, you will need to turn the CD/DVD at an angle when you place it in the disc tray. After seating the CD/DVD, however, make sure it lies flat.



■ Do not touch a laser lens and its circumference portion. Doing so could cause misalignment.

■ Prevent foreign objects from entering the drive. Check the surface of the disc tray, especially the area behind the front edge of the disc tray, to make sure there are no such objects before closing the drive.

4. Press gently at the center of the CD/DVD until you feel it click into place. The CD/DVD should lie below the top of the spindle, flush with the spindle base.
5. Push the center of the disc tray to close it. Press gently until it locks into place.



If the CD/DVD is not seated properly when the disc tray is closed, the CD/DVD might be damaged. Also, the disc tray might not open fully when you press the eject button.

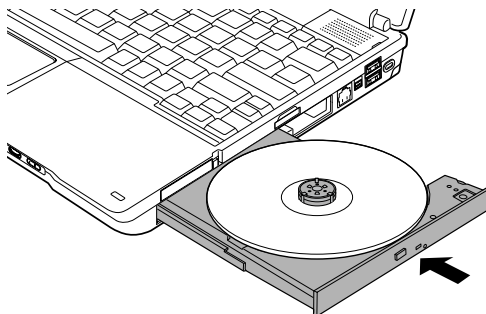

Closing the CD/DVD disc tray

Removing discs

To remove the CD/DVD, follow the steps below.



Do not press the eject button while the computer is accessing the media drive. Wait for the Optical media drive indicator to go out before you open the disc tray. Also, if the CD/DVD is spinning when you open the disc tray, wait for it to stop before you remove it.

1. To pop the disc tray partially open, press the eject button. Gently pull the disc tray out until it is fully opened.



When the disc tray pops open slightly, wait a moment to make sure the CD/DVD has stopped spinning before pulling the disc tray fully open.

2. The CD/DVD extends slightly over the sides of the disc tray so you can hold it. Hold the CD/DVD gently and lift it out.

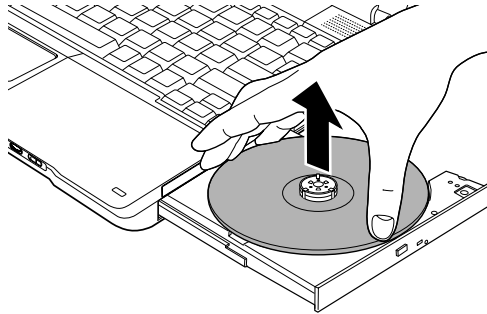

Removing a CD/DVD

3. Push the center of the disc tray to close it. Press gently until it locks into place.

How to remove CD/DVD when the disk tray will not open

Pressing the eject button will not open the disc tray when the computer power is off. If the power is off, you can open the disc tray by inserting a slender object (about 15 mm) such as a straightened paper clip into the eject hole just to the right of the eject button.

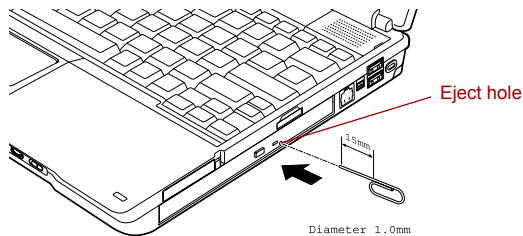

Manual release with the eject hole



Turn off the power before you use the eject hole. If the CD/DVD is spinning when you open the disc tray, the CD/DVD could fly off the spindle and cause injury.

Writing CDs on DVD-ROM&CD-R/RW drive

The DVD-ROM&CD-R/RW drive lets you write as well as read CD-ROMs. Observe the precautions in this section to ensure the best performance for writing CDs. For information on loading and unloading CDs refer to the [Using optical media drives](#) section.



- *CD-R discs can be written to only once. CD-RW discs can be rewritten many times.*
- *When the power of the optical media drive is off, the disc tray will not open even if the eject button is pushed. Use the optical media drive power icon to turn the power of the optical media drive on. Refer to the [Special features](#) section in Chapter 1, Introduction .*
- *Do not turn off the power of the optical media drive while the computer is accessing the drive. If you turn off the power, you may lose data.*

Before writing or rewriting

Please observe the following points when you write or rewrite the data.

- We recommend the following manufacturers of CD-R and CD-RW media. Media quality can affect write or rewrite success rates.

CD-R:

TAIYO YUDEN CO., LTD.
 Mitsui Chemicals Inc.
 MITSUBISHI CHEMICAL CORPORATION
 RICOH Co., Ltd.
 Hitachi Maxell Ltd.

CD-RW:

MITSUBISHI CHEMICAL CORPORATION
 RICOH Co., Ltd.

The following special media recommend the next manufacturers.

Multi-Speed and High-Speed CD-ROM:

MITSUBISHI CHEMICAL CORPORATION
 RICOH Co., Ltd.

Ultra-Speed CD-ROM:

MITSUBISHI CHEMICAL CORPORATION

TOSHIBA has confirmed the operation of CD-R and CD-RW media of the manufacturers above. Operation of other media cannot be guaranteed.

- The actual number of rewrites to CD-RW is affected by the quality of the disc and the way it is used.
- Be sure to connect the AC adaptor when you write or rewrite.
- Be sure to close all other software programs except the writing software.
- Do not run software such as a screen saver which can put a heavy load on the CPU.
- Operate the computer at full power. Do not use power-saving features.
- Do not write while virus check software is running. Wait for it to finish, then disable virus detection programs including any software that checks files automatically in the background.
- Do not use hard disk utilities, including those intended to enhance HDD access speed. They may cause unstable operation and damage data.
- Write from the computer's HDD to the CD. Do not try to write from shared devices such as a LAN server or any other network device.
- Writing with software other than Sonic RecordNow! has not been confirmed. Therefore, operation with other software cannot be guaranteed.

When writing or rewriting

Note the following when you write or rewrite a CD-R or CD-RW.

- Always copy data from the HDD to the CD. Do not use cut-and-paste. The original data will be lost if there is a write error.
- Do not perform any of the following actions:
 - Change users in the Windows XP operating system.
 - Operate the computer for any other function, including use of a mouse or Touch Pad, closing/opening the LCD panel.
 - Start a communication application such as a modem.
 - Apply impact or vibration to the computer.
 - Install, remove or connect external devices, including the following: PC card, CF Card, SD card, USB devices, external monitor, i.LINK devices, optical digital devices.
 - Open the optical media drive.
- If the media is poor in quality, dirty or damaged, writing or rewriting errors may occur.
- Set the computer on a level surface and avoid places subject to vibration such as airplanes, trains or cars. Do not use an unstable surface such as a stand.
- Keep mobile phones and other wireless communication devices away from the computer.

Writing CD/DVDs on DVD Super Multi drive

You can use the DVD Super Multi drive to write data to either CD-R/RW or DVD-R/-RW/+R/+RW/-RAM discs. The following applications for writing are preinstalled: RecordNow!, and DLA licensed by Sonic Solutions. InterVideo WinDVD Creator 2 Platinum, which is a product of InterVideo, Inc.



- *CD-R discs can be written to only once. CD-RW discs can be rewritten many times.*
- *When the power of the optical media drive is off, the disc tray will not open even if the eject button is pushed. Use the optical media drive power icon to turn the power of the optical media drive on. Refer to Chapter 1, [Special features](#).*
- *Do not turn off the power of the optical media drive while the computer is accessing the drive. If you turn off the power, you may lose data.*

Important message

Before you write or rewrite to CD-R/RW or DVD-R/-RW/+R/+RW/-RAM disc, read and follow all setup and operating instructions in this section. If you fail to do so, the DVD Super Multi drive may not function properly, and you may fail to write or rewrite, lose data or incur other damage.

Disclaimer

TOSHIBA does not bear responsibility for the following:

- Damage to any CD-R/RW or DVD-R/-RW/+R/+RW/-RAM disc that may be caused by writing or rewriting with this product.
- Any change or loss of the recorded contents of CD-R/RW or DVD-R/-RW/+R/+RW/-RAM disc that may be caused by writing or rewriting with this product, or for any business profit loss or business interruption that may be caused by the change or loss of the recorded contents.
- Damage that may be caused by using third party equipment or software.

Given the technological limitations of current optical disc writing drives, you may experience unexpected writing or rewriting errors due to disc quality or problems with hardware devices. Also, it is a good idea to make two or more copies of important data, in case of undesired change or loss of the recorded contents.

Before writing or rewriting

- Based on TOSHIBA's limited compatibility testing, we suggest the following manufacturers of CD-R/RW and DVD-R/+R/-RW/+RW/-RAM disc. However, in no event does TOSHIBA guarantee the operation, quality or performance of any disc. Disc quality can affect write or rewrite success rates.

CD-R:

TAIYO YUDEN CO., LTD.
MITSUBISHI CHEMICAL CORPORATION
RICOH Co., Ltd.
Hitachi Maxell Ltd.

CD-RW: (Multi-Speed and High-Speed)

MITSUBISHI CHEMICAL CORPORATION
RICOH Co., Ltd.

CD-RW: (Ultra-Speed)

MITSUBISHI CHEMICAL CORPORATION

DVD-R:

DVD Specifications for Recordable Disc for General Version 2.0
TAIYO YUDEN CO., LTD.
PIONEER VIDEO CORPORATION
Matsushita Electric Industrial Co., Ltd.

DVD+R:

MITSUBISHI CHEMICAL CORPORATION
RICOH Co., Ltd.

DVD-RW:

DVD Specifications for Recordable Disc for Version 1.1 or version 1.2
VICTOR COMPANY OF JAPAN.LIMITED
MITSUBISHI CHEMICAL CORPORATION

DVD+RW:

MITSUBISHI CHEMICAL CORPORATION
RICOH Co., Ltd.

DVD-RAM:

DVD Specifications for DVD-RAM Disc for Version 2.0 or Version 2.1
Matsushita Electric Industrial Co., Ltd.
Hitachi Maxell Ltd.



This drive cannot use discs that allow writing faster than 2 speed (DVD-R, DVD-RW, DVD-RAM), 2.4 speed (DVD+R, DVD+RW).

- If the disc is poor in quality, dirty or damaged, writing or rewriting errors may occur. Be careful to check the disc for dirt or damage before you use it.
- The actual number of rewrites to CD-RW, DVD-RW, DVD+RW or DVD-RAM is affected by the quality of the disc and the way it is used.
- There are two types of DVD-R discs: authoring and general use discs. Do not use authoring discs. Only general use discs can be written to by a computer drive.
- You can use DVD-RAM discs that can be removed from a cartridge and DVD-RAM discs designed without a cartridge. You cannot use a disc with a 4.7 GB single-sided capacity or 9.4 GB double-sided capacity.
- Other DVD-ROM drives for computers or other DVD players may not be able to read DVD-R/-RW or DVD+R/+RW discs.
- Data written to a CD-R/DVD-R/DVD+R disc cannot be deleted either in whole or in part.
- Data deleted (erased) from a CD-RW, DVD-RW, DVD+RW and DVD-RAM disc cannot be recovered. Check the content of the disc carefully before you delete it. If multiple drives that can write data to discs are connected, be careful not to delete data from the wrong drive.
- In writing to a DVD-R/-RW, DVD+R/+RW or DVD-RAM disc, some disc space is required for file management, so you may not be able to write the full capacity of the disc.
- Since the disc is based on the DVD standard, it might be filled with dummy data if the written data is less than about 1 GB. Even if you write only a small amount of data, it might take time to fill in the dummy data.
- DVD-RAM formatted by FAT32 cannot be read in Windows 2000 without DVD-RAM Driver Software.
- When multiple drives that can write data to discs are connected, be careful not to write to the wrong drive.
- Be sure to connect the AC adaptor before you write or rewrite.
- Before you enter standby/hibernation mode, be sure to finish DVD-RAM writing. Writing is finished if you can eject DVD-RAM media.
- Be sure to close all other software programs except the writing software.
- Do not run software such as a screen saver, which can put a heavy load on the CPU.
- Operate the computer in the full-power mode. Do not use power-saving features.
- Do not write while virus check software is running. Wait for it to finish and then disable virus detection programs including any software that checks files automatically in the background.
- Do not use hard disk utilities, including those intended to enhance HDD access speed. They may cause unstable operation and data damage.

- CD-RW (Ultra Speed +) media is not available. If used, data may be lost or damaged.
- Write from the computer's HDD to the CD/DVD. Do not try to write from shared devices such as a LAN server or any other network device.
- Writing with software other than RecordNow! and InterVideo WinDVD Creator Platinum are not recommended.

When writing or rewriting

Please observe/consider the following when you write or rewrite to a CD-R/RW, DVD-R/-RW/-RAM or DVD+R/+RW disc.

- Do not perform any of the following actions when writing or rewriting:
 - Change users in the Windows XP operating system.
 - Operate the computer for any other function, including using a mouse or Touch Pad or closing/opening the LCD panel.
 - Start a communication application such as a modem.
 - Apply impact or vibration to the computer.
 - Install, remove or connect external devices, including the following: PC card, CF card, SD card, USB devices, external monitor, i.LINK devices, optical digital devices.
 - Use the Audio/Video control button to reproduce music or voice.
 - Open the DVD Super Multi drive.
- Do not use shut down/log off and standby/hibernation while writing or rewriting.
- Make sure writing or rewriting is completed before going into standby/hibernation. Writing is completed if you can open the DVD-ROM&CD-R/RW or DVD Super Multi drive tray.
- Set the computer on a level surface and avoid places subject to vibration such as airplanes, trains, or cars. Do not use an unstable surface such as a stand.
- Keep mobile phones and other wireless communication devices away from the computer.
- Always copy data from the HDD to the DVD-RAM. Do not use cut-and-paste. The original data will be lost if there is a write error.

RecordNow! Basic for TOSHIBA

Note the following limitations when you use RecordNow!:

- DVD-Video cannot be created using RecordNow!.
- DVD-Audio cannot be created using RecordNow!.
- You cannot use RecordNow!'s "Audio CD for Car or Home CD Player" function to record music to the DVD-R/-RW or DVD+R/+RW disc.
- Do not use the "Exact Copy" function of RecordNow! to copy DVD-Video and DVD-ROM with copyright protection.
- DVD-RAM disc cannot be backed up with the "Exact Copy" function of RecordNow!.

- You cannot back up a CD-ROM or CD-R/RW to DVD-R/-RW or DVD+R/+RW using the “Exact Copy” function of RecordNow!.
- You cannot back up DVD-ROM, DVD-Video or DVD-R/-RW or DVD+R/+RW to CD-R/RW using the “Exact Copy” function of RecordNow!.
- RecordNow! cannot record in packet format.
- You might not be able to use the “Exact Copy” function of RecordNow! to back up a DVD-R/-RW or DVD+R/+RW disc that was made with other software on a different DVD-R/-RW or DVD+R/+RW recorder.
- If you add data to a DVD-R and DVD+R disc that you have already recorded to, you might not be able to read the added data under some circumstances. It cannot be read in 16-bit operating systems, such as Windows 98SE and Windows Me. In Windows NT4, you will need Service Pack 6 or later to read added data. In Windows 2000, you will need Service Pack 2 or later to read it. Some DVD-ROM and DVD-ROM&CD-R/RW drives cannot read added data regardless of the operating system.
- RecordNow! does not support recording to DVD-RAM discs. To record to a DVD-RAM, use Explorer or other utility.
- When you back up a DVD disc, be sure the source drive supports recording to DVD-R/-RW or DVD+R/+RW discs. If the source drive does not support recording to DVD-R/-RW or DVD+R/+RW discs, it might not be backed up correctly.
- When you back up a DVD-R, DVD-RW, DVD+R or DVD+RW, be sure to use the same type of disc.
- You cannot partially delete any data written to a CD-RW, DVD-RW or DVD+RW disc.

Data Verification

To verify that data is written or rewritten correctly, follow the steps below before you write or rewrite a Data CD/DVD.

1. Click the **Options** button () on the RecordNow! Console to open the Options panels.
2. Select the Data in the left-side menu.
3. Mark the Verify data written to the disc after burning check box in the Data Options.

Click the **OK** button.

DLA for TOSHIBA

Note the following limitations when you use DLA:

- This software supports only rewritable discs (DVD+RW, DVD-RW, and CD-RW). It does not support DVD+R, DVD-R, and CD-R discs that are not rewritable.
- DLA does not support formatting a DVD-RAM disc and writing to it. They are performed by DVD-RAM Driver Software. If DLA Format menu may appear when inserting a DVD-RAM disc into the drive and right-clicking the drive icon in Windows Explorer, please use "DVDForm" to format this disc. You can run "DVDForm" by clicking the Start button on the taskbar to display the Start menu and then selecting "All Programs", "DVD-RAM", "DVD-RAM Driver" and "DVDForm" sequentially.
- Do not use any discs that have been formatted with packet writing software other than DLA. Similarly, do not use any discs that have been formatted with DLA with any packet writing software other than DLA. When using a disc you are not familiar with, format it by selecting "Full Format" before using it.
- Do not use the Cut & Paste function for files and folders. A file or folder that has been cut may be lost if writing fails due to an error on the disc.
- When writing the Setup files for the program to a disc formatted by DLA and starting Setup from this disc, an error may occur. In this case, please copy them to your hard disk and then run Setup.

When WinDVD Creator Platinum is used:

You can record video back to your digital camcorder via i.LINK (IEEE1394) using WinDVD Creator Platinum. However, there is a case where its playback sound is choppy.

1. Click **start** and select the **Control Panel**.
2. Click the **Performance and Maintenance** icon in the Control Panel.
3. Click the **System** icon in the Performance and Maintenance window.
4. Click the **Advanced** tab in the System Properties window.
5. Click the **Settings** icon in the "Performance" section.
6. Click the **Advanced** tab in the Performance Options window.
7. Click the **Change** icon in the "virtual memory" section.
8. Select the **Custom size** button in the Virtual Memory window.
9. Specify much higher values for "Initial size" and "Maximum size."
10. Click the **Set** button in the Virtual Memory window.
11. Click the **OK** button in the Virtual Memory window.

How to make a DVD-Video

Simplified steps for making a DVD-Video from video data captured from a DV-Camcorder:

1. Click [Start]-[All Programs] - [InterVideo WinDVD Creator2] - [InterVideo WinDVD Creator] to launch WinDVD Creator.
2. Click [Capture] button then capture the video data from the DV-Camcorder via IEEE1394.
3. Click [Edit] button then drag the video clips from [Video Library] tab to the edit track.
4. Click [Make Movie] button in the top bar.
5. Double Click the Right arrow button icon in the center of right side.
6. Put a blank DVD-R/+R disc or an erased DVD-RW/+RW disc in the drive.
7. Click [Start] to record to the disc.
8. When recording is finished, the tray opens.

How to learn more about InterVideo WinDVD Creator

Please refer to the on-line Help for additional InterVideo WinDVD Creator information.

Important information for use

Note the following limitations when you write video DVD:

1. Editing digital video
 - Log in with Administrator rights to use WinDVD Creator.
 - Make sure that your computer is running on AC power when using WinDVD Creator.
 - Operate the computer at Full Power. Do not use power-saving features.
 - While you are editing DVD, you can display previews. However, if another application is running, the preview might not display properly.
 - WinDVD Creator cannot show video on the external monitor when in simultaneous mode.
 - WinDVD Creator cannot edit or play copy protected content.
 - Do not change display settings while using WinDVD Creator.
 - Do not enter standby/hibernation mode while using WinDVD Creator.
 - Do not operate WinDVD Creator immediately after turning on the computer. Please wait until all Disc Drive activity has stopped.
 - When recording to a DV-Camcorder, to ensure you capture all of your data, let the camcorder record for a few seconds before you begin recording your actual data.
 - CD recorder, JPEG functions, DVD-Audio, mini DVD and Video CD functions are not supported in this version.

- While recording video to DVD or tape, please close all other programs.
 - Do not run software like a screen saver because it can put a heavy load on the CPU.
 - Do not run communication applications like a modem or a LAN.
2. Before recording the video to DVD
- When you record to DVD disc, please use only discs recommended by the Drive manufacturer.
 - Do not set the working drive to a slow device like a USB 1.1 hard disk drive or it will fail to write DVD.
 - Do not perform any of the following actions:
 - Operate the computer for any other function, including using a mouse or Touch Pad or closing/opening the LCD panel.
 - Bump or cause vibration to the computer.
 - Use the Mode control button and Audio/Video control button to reproduce music or voice.
 - Open the DVD drive.
 - Install, remove or connect external devices, including the following: PC card, CF card, SD card, USB devices, external monitor, i.LINK devices, optical digital devices.
 - Please verify your disc after recording important data.
 - DVD-R/+R/-RW disc cannot be written in VR format.
 - WinDVD Creator cannot export to DVD-Audio, VideoCD, miniDVD format.
 - WinDVD Creator can write DVD-RAM/+RW in VR format, but the disc may only play on your computer.
 - When writing to DVD disc, WinDVD Creator requires 2GB or more over disk space every one hour of video.
 - When you make a fully recorded DVD, the chapter sequence may not play correctly.
3. About Disc Manager
- WinDVD Creator can edit one play list on a disc.
 - WinDVD Creator might show a different a thumbnail than you previously set in CE (Consumer Electronics) DVD-RAM recorder.
 - Using the Disc Manager, you can edit DVD-VR format on DVD-RAM, DVD+VR format on DVD+RW, and DVD-Video format on DVD-RW.
4. About recorded DVDs
- Some DVD-ROM drives for personal computers or other DVD players may not be able to read DVD-R/+R/-RW/+RW/-RAM discs.
 - When playing your recorded disc on your computer, please use the WinDVD software application.
 - If you use an over-used rewritable disc, the full formatting might be locked. Please use a brand new disc.

Media care

This section provides tips on protecting data stored on your CD/DVDs and floppy disks.

Handle your media with care. The following simple precautions will increase the lifetime of your media and protect the data stored on them:

CD/DVDs

1. Store your CD/DVDs in the container they came in to protect them and keep them clean.
2. Do not bend the CD/DVD.
3. Do not write on, apply a sticker to, or otherwise mar the surface of the CD/DVD that contains data.
4. Hold the CD/DVD by its outside edge or the edge on the center hole. Fingerprints on the surface can prevent the drive from properly reading data.
5. Do not expose to direct sunlight, extreme heat or cold. Do not place heavy objects on your CD/DVDs.
6. If your CD/DVDs become dusty or dirty, wipe them with a clean dry cloth. Wipe from the center out, do not wipe in a circular direction around the CD/DVD. If necessary, use a cloth dampened in water or a neutral cleaner. Do not use benzine, thinner or similar cleaner.

Floppy disks

1. Store your floppy disks in the container they came in to protect them and keep them clean. If a floppy disk is dirty, do not use cleaning fluid. Clean it with a soft damp cloth.
2. Do not slide back the floppy disk's protective metal covering or touch the floppy disk's magnetic surface. Fingerprints may prevent the floppy disk drive from reading data from the floppy disk.
3. Data may be lost if the floppy disk is twisted; bent; or exposed to direct sunlight, extreme heat or cold.
4. Do not place heavy objects on your floppy disks.
5. Do not eat, smoke, or use erasers near your floppy disks. Foreign particles inside the floppy disk's jacket can damage the magnetic surface.
6. Magnetic energy can destroy the data on your floppy disks. Keep your floppy disks away from speakers, radios, television sets and other sources of magnetic fields.

Sound System

This section describes audio controls including sound levels and power management.

Volume Control

The Volume Control utility lets you control the audio volume in Windows for both playback and recording.

- To launch Volume Control for playback, click **start**, point to **All Programs**, point to **Accessories**, point to **Entertainment** and click **Volume Control**.
- To launch Recording Control, click **Options**, point to **Properties**, choose **Recording** and click **OK**.
- To view details of the Volume Control, click **Help** on the Volume Control.

Microphone level

To change the microphone gain, follow the steps below.

1. Click **start**, point to **All Programs**, point to **Accessories**, point to **Entertainment** and click **Volume Control**.
2. Click **Options** and point to **Properties**.
3. Select **Recording** and click **OK**.
4. Click **Options** and select **Advanced Controls**.
5. Click **Advanced**.
6. Check the **Microphone Boost** checkbox.

Audio controller

The audio controller can be powered down when the audio function is idle. To enable Audio Power Management, follow the steps below.

1. Click **start** and click **Control Panel**.
2. If you are viewing the Control Panel in Category View, click on **Switch to Classic View**.
3. Double-click the **SigmaTel Audio** icon.

Power management

1. Clicked the **Advanced** tab.
2. Select the **Enable Power Management** check box.
3. Input a time in **Time to Power Saving State**.



*If the **Enable Power Management** check box is not selected, the audio controller always runs.*

Sound quality

Adjust the equalizer settings to enhance sound quality.

Modem

This section describes how to connect and disconnect the internal modem to and from a telephone jack.



The internal modem does not support voice functions. All data and fax functions are supported.



- *In case of a lightning storm, unplug the modular cable from the telephone jack.*
- *Do not connect the modem to a digital telephone line. A digital line will damage the modem.*

Region selection

Telecommunication regulations vary from one region to another, so you will need to make sure the internal modem's settings are correct for the region in which it will be used.

To select a region, follow the steps below.

1. Click **start**, point to **All Programs**, point to **TOSHIBA**, point to **Networking** and click **Modem Region Select**.



Do not use the Country/Region Select function in the Modem setup utility in the Control Panel if the function is available. If you change the Country/Region in the Control Panel, the change may not take effect.

2. The Region Selection icon will appear in the Windows Task Bar.
3. Click the icon with the primary mouse button to display a list of regions that the modem supports. A sub menu for telephony location information will also be displayed. A check will appear next to the currently selected region and telephony location.
4. Select a region from the region menu or a telephony location from the sub-menu.
 - When you click a region it becomes the modem's region selection, and the New Location for telephony will be set automatically.
 - When you select a telephony location, the corresponding region is automatically selected and it becomes the modem's current region setting.

Properties menu

Click the icon with the secondary mouse button to display properties menu on the screen.

Setting

You can enable or disable the following settings:

AutoRun Mode

The Region Select utility starts automatically when you start up the operating system.

Open the Dialing Properties dialog box after selecting region.

The dialing properties dialog box will be displayed automatically after you select the region.

Location list for region selection.

A submenu appears displaying location information for telephony.

Open dialog box, if the modem and Telephony Current Location region code do not match.

A warning dialog box is displayed if current settings for region code and telephony location are incorrect.

Modem Selection

If the computer cannot recognize the internal modem, a dialog box is displayed. Select the COM port for your modem to use.

Dialing Properties

Select this item to display the dialing properties.



If you are using the computer in Japan, the Telecommunications Business Law requires that you select Japan region mode. It is illegal to use the modem in Japan with any other selection.

Connecting

To connect the modular cable, follow the steps below.



The modular cable that comes with the computer must be used to connect a modem. Connect the end of the modular cable with the core to the computer.



- *In case of a lightning storm, unplug the modular cable from the telephone jack.*
- *Do not connect the modem to a digital telephone line. A digital line will damage the modem.*

1. Plug one end of the modular cable into the computer's modem jack.

2. Plug the other end of the modular cable into a telephone jack.

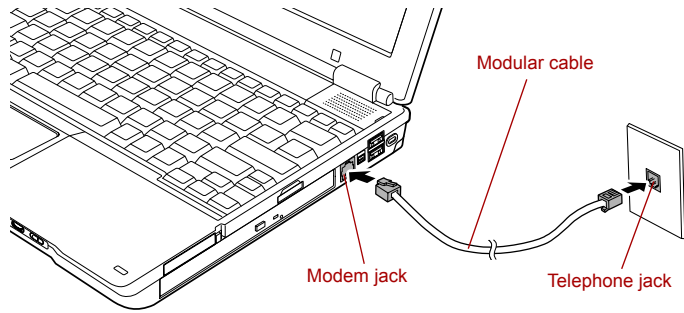

Connecting the internal modem



Do not pull on the cable or move the computer while the cable is connected.



If you use a storage device such as an optical drive or HDD connected to a 16-bit PC card, you might experience the following modem problems:

- *Modem speed is slow or communication is interrupted.*
- *Skips may occur in sound.*

Disconnecting

To disconnect the internal modular cable, follow the steps below.

1. Pinch the lever on the connector in the telephone jack and pull out the connector.
2. Disconnect the cable from the computer's modem jack in the same manner.

Wireless communications

The computer's wireless communication function supports both Wireless LAN and Bluetooth devices.

Bluetooth is provided with some models in this series.

Wireless LAN

The Wireless LAN is compatible with other LAN systems based on Direct Sequence Spread Spectrum /Orthogonal Frequency Division Multiplexing radio technology that complies with IEEE802.11 Wireless LAN standard (Revision A, B or G) and Turbo Mode.

- Theoretical maximum speed: 54Mbps (IEEE802.11a, 802.11g)
- Theoretical maximum speed: 11Mbps (IEEE802.11b)
- Theoretical maximum speed: 108Mbps (Turbo Mode; Atheros module type)
- Frequency Channel Selection (Revision A:5 GHz, Revision B/G: 2.4 GHz)
- Roaming over multiple channels
- Card Power Management
- Atheros Super G™ or Super AG™ technology (Atheros module type).
- Wired Equivalent Privacy (WEP) data encryption, based on the 152 bit encryption algorithm (Atheros module type).
- Wired Equivalent Privacy (WEP) data encryption, based on the 128 bit encryption algorithm (Intel module type).
- Advanced Encryption Standard (AES) data encryption, based on 256 bit encryption algorithm (Atheros module type).
- Wi-Fi Protected Access (WPA).



- *The numerical values for display are the theoretical maximums for Wireless LAN standards. The actual values may differ.*
 - *The transmission speed over the wireless LAN and the distance over which wireless LAN can reach may vary depending on surrounding electromagnetic environment, obstacles, access point design and configuration, and client design and software/hardware configurations. The Transmit Rate (xx Mbit/s) is the theoretical maximum speed under the IEEE802.11 (a/b/g) standard. The actual transmission speed will be lower than the theoretical maximum speed.*
- To use the Atheros SuperG™ or SuperAG™ function, your client and access point must support the corresponding feature. Performance of these functions may vary depending on the format of data transmitted.*

Security

- Be sure to enable WEP (encryption) function. Otherwise your computer will allow the illegal access by outsider through Wireless LAN to cause illegal intrusion, eavesdropping, and loss or destruction of stored data. TOSHIBA strongly recommend the customer to enable the WEP function.
- TOSHIBA is not liable for the eavesdropping of data due to the use of Wireless LAN and the damage thereof.

Bluetooth wireless technology

Bluetooth™ wireless technology eliminates the need for cables between electronic devices such as desktop computers, printers and mobile phones. You cannot use the built-in Bluetooth functions and an optional Bluetooth SD card 3 simultaneously.

Bluetooth wireless technology has the following features:

Worldwide operation

The Bluetooth radio transmitter and receiver operate in the 2.4 GHz band, which is license-free and compatible with radio systems in most countries in the world.

Radio links

You can easily establish links between two or more devices. The link is maintained even if the devices are not within line of sight.

Security

Two advanced security mechanisms ensure a high level of security:

- Authentication prevents access to critical data and makes it impossible to falsify the origin of a message.
- Encryption prevents eavesdropping and maintains link privacy.

Bluetooth™ Stack for Windows® by TOSHIBA

Please note that this software is specifically designed for the following operating systems:

- Microsoft® Windows® 2000 Professional
- Microsoft® Windows® XP

Detailed information regarding the use with these operating systems is listed below. Please refer also to the electronic information which is included with each software.



This Bluetooth™ Stack is based on Bluetooth™ Version 1.1/1.2 specification. TOSHIBA cannot confirm all compatibility among any PC products and/or other electronic devices using Bluetooth™ other than TOSHIBA mobile PCs.

Release Notes related to the Bluetooth™ Stack for Windows® by TOSHIBA

1. Install:
On Windows2000 or Windows XP, Bluetooth™ Stack for Windows® by TOSHIBA does not need signature.
2. Fax application software:
Regarding FAX application software, there are some software that you cannot use on this Bluetooth™ Stack.
3. Multi User:
On Windows XP, Multi user does not supported.
When you use Bluetooth, you might not use Bluetooth another logon user.

Product Support:

The latest information regarding Operating System support, Language Support or available upgrades can be found on our web site <http://www.toshiba-europe.com/computers/tnt/bluetooth.htm> in Europe or www.pcsupport.toshiba.com in the United States.

Wireless communication switch

You can enable or disable Wireless LAN and Bluetooth functions, with the on/off switch. No transmissions are sent or received when the switch is off. Slide the switch to the right to turn it on and to the left to turn it off.



- *Set the switch to off in airplanes and hospitals. Check the indicator. It will stop glowing when the wireless communication function is off.*
- *Turn the computer off when you enter an airplane and check the carrier's regulations before you use a computer on board.*

Wireless communication Indicator

The wireless communication indicator indicates the status of the wireless communication functions.

Indicator status	Indication
Indicator off	Wireless communication switch is set to off. Automatic power down because of overheating. Power malfunction
Indicator glows	Wireless communication switch is on. Wireless LAN or Bluetooth is turned on by an application.

If you used the Task Bar to disable W-LAN, restart the computer or follow the procedures below to enable the system to recognize W-LAN. Open or click the following: **start, Control Panel, System, Hardware, Device Manager, Network adapters, Intel® PRO/Wireless 2200BG/2915ABG Network Connection or Atheros AR5004G/AR5004X Wireless Network Adapter** and **enable**.

LAN

The computer has built-in support for Ethernet LAN (10 megabits per second, 10BASE-T) and Fast Ethernet LAN (100 megabits per second, 100BASE-TX).

This section describes how to connect/disconnect to a LAN.



Do not install or remove an optional memory module while Wake-up on LAN is enabled.



The Wake-up on LAN function consumes power even when the system is off. Leave the AC adaptor connected while using this feature.

LAN cable types



The computer must be configured properly before connecting to a LAN. Logging onto a LAN using the computer's default settings could cause a malfunction in LAN operation. Check with your LAN administrator regarding set-up procedures.

If you are using Fast Ethernet LAN (100 megabits per second, 100BASE-TX), be sure to connect with a CAT5 cable or higher. You cannot use a CAT3 cable.

If you are using Ethernet LAN (10 megabits per second, 10BASE-T), you can connect with either a CAT5 or a CAT3.

Connecting LAN cable

To connect the LAN cable, follow the steps below.



- *Connect the AC adaptor before connecting the LAN cable. The AC adaptor must remain connected during LAN use. If you disconnect the AC Adaptor while the computer is accessing a LAN, the system may hang up.*
- *Do not connect any other cable to the LAN jack except the LAN cable. Otherwise, malfunctions or damage may occur.*
- *Do not connect any power supplying device to the LAN cable that is connected to the LAN jack. Otherwise, malfunctions or damage may occur.*

1. Turn off the power to the computer and to all external devices connected to the computer.
2. Plug one end of the cable into the LAN jack. Press gently until you hear the latch click into place.

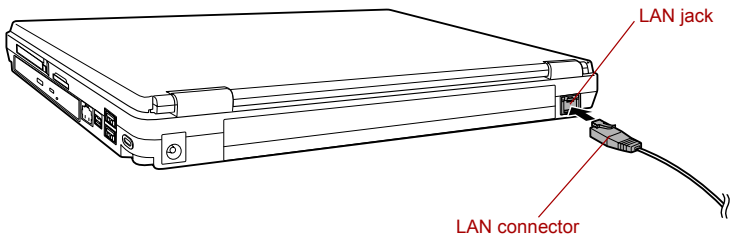

Connecting the LAN cable

3. Plug the other end of the cable into a LAN hub connector. Check with your LAN administrator before connecting to a hub.



*When the computer is exchanging data with the LAN, the **LAN Active** indicator glows orange. When the computer is connected to a LAN hub but is not exchanging data, the **Link** indicator glows green.*

Disconnecting LAN cable

To disconnect the LAN cable, follow the steps below.



*Make sure the **LAN Active** indicator (orange LED) is out before you disconnect the computer from the LAN.*

1. Pinch the lever on the connector in the computer's LAN jack and pull out the connector.
2. Disconnect the cable from the LAN hub in the same manner. Check with your LAN administrator before disconnecting from the hub.

Cleaning the computer

To help ensure long, trouble-free operation, keep the computer free of dust and use care with liquids around the computer.

- Be careful not to spill liquids into the computer. If the computer does get wet, turn the power off immediately and let the computer dry completely before you turn it on again.
- Clean the computer using a slightly damp (with water) cloth. You can use glass cleaner on the LCD display screen. Spray a small amount of cleaner on a soft, clean cloth and wipe the screen gently with the cloth.



Never spray cleaner directly onto the computer or let liquid run into any part of it. Never use harsh or caustic chemical products to clean the computer.

Moving the computer

The computer is designed for rugged durability. However, a few simple precautions taken when moving the computer will help ensure trouble-free operation.

- Make sure all disk activity has ended before moving the computer. Check the **HDD** indicator on the computer.
- If a CD/DVD is in the drives, remove it. Also make sure the disc tray is securely closed.
- Turn off the power to the computer.
- Disconnect the AC adaptor and all peripherals before moving the computer.
- Close the LCD display panel. Do not pick up the computer by its panel.
- Close all port covers.
- Use the carrying case when transporting the computer.
- When carrying your computer, be sure to hold it securely so that it does not fall or hit anything.
- Do not carry your computer by holding protruded portions.

Heat dispersal

To protect from overheating, the CPU has an internal temperature sensor. If the computer's internal temperature rises to a certain level, the cooling fan is turned on or the processing speed is lowered. You can select whether to control the CPU temperature by turning on the fan first, then if necessary, lowering the CPU speed. Or, by lowering the CPU speed first, then if necessary, turning on the fan. Use the *Cooling Method* item of the *Basic Setup* tab in TOSHIBA Power Saver.

Maximum Performance	Turns on the fan first, then if necessary, lowers the CPU processing speed.
----------------------------	-----------------------------------------------------------------------------

Performance	Uses a combination of the fan and lowering the CPU processing speed.
--------------------	----------------------------------------------------------------------

Battery optimized	Lowers the CPU processing speed first, then if necessary turns on the fan.
--------------------------	----------------------------------------------------------------------------

When the CPU temperature falls to a normal range, the fan is turned off and the CPU operation returns to standard speed.



If the CPU temperature reaches an unacceptably high level with either setting, the system automatically shuts down to prevent damage. Data in memory will be lost.

The Keyboard

The computer's keyboard layouts are compatible with a 101/102-key enhanced keyboard. By pressing some keys in combination, all the 101/102-key keyboard functions can be executed on the computer.

The number of keys on your keyboard depends on which country/region's keyboard layout your computer is configured with. Keyboards for numerous languages are available.

There are six types of keys: typewriter keys, function keys, soft keys, Hot keys, Windows special keys and keypad overlay.

Typewriter keys

The typewriter keys produce the upper- and lower-case letters, numbers, punctuation marks, and special symbols that appear on the screen.

There are some differences, however, between using a typewriter and using a computer keyboard:

- Letters and numbers produced in computer text vary in width. Spaces, which are created by a "space character," may also vary depending on line justification and other factors.
- The lowercase l (el) and the number 1 (one) are not interchangeable on computers as they are on a typewriter.
- The uppercase O (oh) and the 0 (zero) are not interchangeable.
- The **Caps Lock** function key locks only the alphabetic characters in uppercase while the shift lock on a typewriter places all keys in the shifted position.
- The **Shift** keys, the **Tab** key, and the **BkSp** (backspace) key perform the same function as their typewriter counterparts but also have special computer functions.

Function keys: F1 ... F12

The function keys (not to be confused with **Fn**) are the 12 keys at the top of your keyboard. These keys function differently from other keys.



F1 through **F12** are called function keys because they execute programmed functions when pressed. Used in combination with the **Fn** key, keys marked with icons execute specific functions on the computer. Refer to the section, [Soft keys: Fn key combinations](#), in this chapter. The function executed by individual keys depends on the software you are using.

Soft keys: Fn key combinations

The **Fn** (function) is unique to TOSHIBA computers and is used in combination with other keys to form soft keys. Soft keys are key combinations that enable, disable or configure specific features.



Some software may disable or interfere with soft-key operations. Soft-key settings are not restored by the Standby feature.

Emulating keys on enhanced keyboard

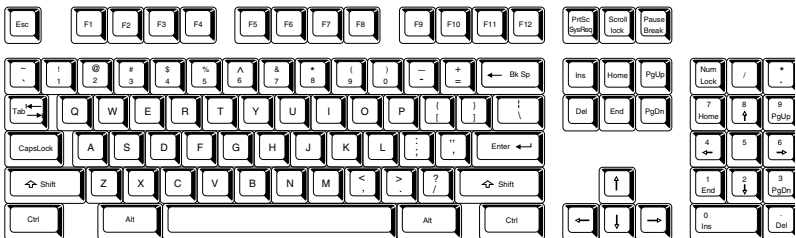

A 101-key enhanced keyboard layout

The keyboard is designed to provide all the features of the 101-key enhanced keyboard, shown in the above figure. The 101/102-key enhanced keyboard has a numeric keypad and scroll lock key. It also has additional **Enter** and **Ctrl** keys to the right of the main keyboard. Since the keyboard is smaller and has fewer keys, some of the enhanced keyboard functions must be simulated using two keys instead of one on the larger keyboard.

Your software may require you to use keys that the keyboard does not have. Pressing the **Fn** key and one of the following keys simulates the enhanced keyboard's functions.

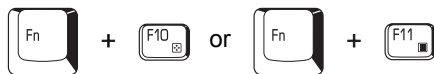

Press **Fn + F10** or **Fn + F11** to access the integrated keypad. When activated, the keys with gray markings on the bottom edge become numeric keypad keys (**Fn + F11**) or cursor control keys (**Fn + F10**). Refer to the [Keypad overlay](#) section in this chapter for more information on how to operate these keys. The power on default for both settings is off.



Press **Fn + F12 (ScrLock)** to lock the cursor on a specific line. The power on default is off.



Press **Fn + Enter** to simulate **Enter** on the enhanced keyboard's numeric keypad.



Press **Fn + Ctrl** to simulate the enhanced keyboard's right **Ctrl** key.

Hot keys

Hot keys (**Fn + a function or Esc** key) let you enable or disable certain features of the computers.



Sound mute: Pressing **Fn + Esc** in a Windows environment turns sound on or off. When you press these hot keys, the current setting will change and be displayed as an icon.



Instant security: Press **Fn + F1** to blank the screen to prevent others from accessing your data. To restore the screen and original settings, press any key or press the Touch Pad. If a screensaver password is registered, a dialog box will appear. Enter the screensaver password and click **OK**. If no password is set, the screen will be restored when you press any key or press the Touch Pad.



Power save mode: Pressing **Fn + F2** changes the power save mode. If you press **Fn + F2** in a Windows environment, the settings dialog box for the Power Save Mode, similar to the one below, is displayed. Continue holding down **Fn**, and release and press **F2** again to toggle between the settings. Release both **Fn** and **F2** to put the new setting into effect. You can also change this setting through the *Profile* options in TOSHIBA Power Saver.



Standby: When you press **Fn + F3**, the computer enters the Standby mode. Before entering Standby, a dialog box appears asking for your confirmation. This dialog box will not be displayed in the future when you click the check box in it.



Hibernation: When you press **Fn + F4**, the computer enters the Hibernation mode. Before entering Hibernation, a dialog box appears asking for your confirmation. This dialog box will not be displayed in the future when you click the check box in it.



Display selection: Press **Fn + F5** to change the active display device. When you press these hot keys, a dialog box appears. Only selectable devices will be displayed. Hold down **Fn** and press **F5** again to change the device. When you release **Fn** and **F5**, the selected device will change. If you hold down these hot keys for five seconds the selection will return to the internal **LCD**.



Internal LCD screen Brightness: Pressing **Fn + F6** decreases the LCD screen brightness in decrements. When you press these hot keys, the current setting will be displayed for two seconds by an icon. You can also change this setting through the *Screen brightness* item of the *Basic Setup* tab in TOSHIBA Power Saver.



Internal LCD screen Brightness: Pressing **Fn + F7** increases the LCD screen brightness in increments. When you press these hot keys, the current setting will be displayed for two seconds by a pop-up icon. You can also change this setting through the *Screen brightness* item of the *Basic Setup* tab in TOSHIBA Power Saver.



- *The brightness level is always set at the maximum value for about 18 seconds, when the internal LCD screen turns on. After 18 seconds, the brightness level will appear at the Power Save Mode setting or you can change it manually.*
- *LCD screen clarity increases with the brightness level.*



Wireless setting: If your computer has both Bluetooth and wireless LAN functions, you can press **Fn + F8** to select which type of wireless communication you want to use. When you press these hot keys, a dialog box will appear. Continue holding down **Fn** and press **F8** to change the setting. If wireless communication is turned off, **Disabled Wireless Communication Switch** will be displayed.



If no wireless communication device is installed, no dialog box will appear.



Touch Pad: Pressing **Fn + F9** in a windows environment enables or disables the Touch Pad function. When you press these hot keys, the current setting will change and be displayed as an icon.



LCD screen resolution selection: Press **Fn + Space** keys to change the LCD screen resolution. Each time when you press these hot keys, the LCD screen resolution changes as follows: With XGA, you can change the resolution between 800 × 600 and 1024 × 768 pixels.



Optical media drive power icon: Press the **Fn + Tab** keys to turn the power of the optical media drive on or eject the disc tray. A dialog box is displayed when this hotkey is pressed. To choose between the functions, press the **Tab** key while holding down the **Fn** key. The chosen function is executed when the **Fn + Tab** keys are released.



TOSHIBA Zooming Utility (reduce): To reduce the icon size on the desktop or the application window, press the **1** key while holding down the **Fn** key.



TOSHIBA Zooming Utility (enlarge): To enlarge the icon size on the desktop or the application window, press the **2** key while holding down the **Fn** key.

Fn Sticky key

You can use the TOSHIBA Accessibility Utility to make the **Fn** key sticky, that is, you can press it once, release it, and then press an “**F number**” key. To start the TOSHIBA Accessibility Utility, click **start**, point to **All Programs**, point to **TOSHIBA**, point to **Utilities** and click **Accessibility**.

Windows special keys

The keyboard provides two keys that have special functions in Windows: Windows logo key activates the **start** menu and the other, the application key, has the same function as the secondary mouse button.



This key activates the Windows **start** menu.



This key has the same function as the secondary mouse button.

Keypad overlay

Your computer's keyboard does not have an independent numeric keypad, but its numeric keypad overlay functions like one.

The keys in the center of the keyboard with gray letters make up the numeric keypad overlay. The overlay provides the same functions as the numeric keypad on the 101/102-key enhanced keyboard in the figure below.

Turning on the overlays

The numeric keypad overlay can be used for numeric data input or cursor and page control.

Arrow mode

To turn on the Arrow mode, press **Fn + F10**. The Arrow mode indicator lights. Now try cursor and page control using the keys shown in the figure below. Press **Fn + F10** again to turn off the overlay.

Numeric mode

To turn on the Numeric mode, press **Fn + F11**. The Numeric mode indicator lights. Now try numeric data entry using the keys in the figure below. Press **Fn + F11** again to turn off the overlay.

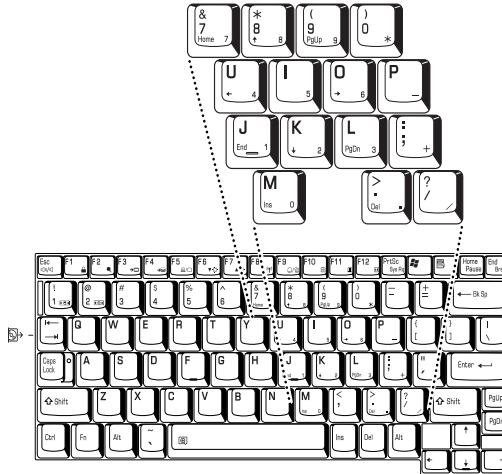

The numeric keypad overlay

Temporarily using normal keyboard (overlay on)

While using the overlay, you can temporarily access the normal keyboard without turning off the overlay:

1. Hold **Fn** and press any other key. All keys will operate as if the overlay were off.
2. Type upper-case characters by holding **Fn + Shift** and pressing a character key.
3. Release **Fn** to continue using the overlay.

Temporarily using overlay (overlay off)

While using the normal keyboard, you can temporarily use the keypad overlay without turning it on:

1. Press and hold down **Fn**.
2. Check the keyboard indicators. Pressing **Fn** turns on the most recently used overlay. If the Numeric mode indicator lights, you can use the overlay for numeric entry. If the Arrow mode indicator lights, you can use the overlay for cursor and page control.
3. Release **Fn** to return to normal keyboard operation.

Temporarily changing modes

If the computer is in **Numeric mode**, you can switch temporarily to **Arrow mode** by pressing a shift key.

If the computer is in **Arrow mode**, you can switch temporarily to **Numeric mode** by pressing a shift key.

Generating ASCII characters

Not all ASCII characters can be generated using normal keyboard operation. But, you can generate these characters using their ASCII codes.

With the overlay on:

1. Hold down **Alt**.
2. Using the overlay keys, type the ASCII code.
3. Release **Alt**, and the ASCII character appears on the display screen.

With the overlay off:

1. Hold down **Alt + Fn**.
2. Using the overlay keys, type the ASCII code.
3. Release **Alt + Fn**, and the ASCII character appears on the display screen.

Chapter 6

Power and Power-Up Modes

The computer’s power resources include the AC adaptor, battery pack and internal batteries. This chapter gives details on making the most effective use of these resources including charging and changing batteries, tips for saving battery power, and power up modes.

Power conditions

The computer’s operating capability and battery charge status are affected by the power conditions: whether an AC adaptor is connected, whether a battery pack is installed and what the charge level is for the battery.

Power conditions

		Power on	Power off (no operation)
AC adaptor connected	Battery fully charged	<ul style="list-style-type: none"> Operates LED: Battery green DC IN green 	<ul style="list-style-type: none"> LED: Battery green DC IN green
	Battery partially charged or no charge	<ul style="list-style-type: none"> Operates Quick Charge LED: Battery orange DC IN green 	<ul style="list-style-type: none"> Quick charge LED: Battery orange DC IN green
	No battery installed	<ul style="list-style-type: none"> Operates No charge LED: Battery off DC IN green 	<ul style="list-style-type: none"> No charge LED: Battery off DC IN green

Power conditions continued

		Power on	Power off (no operation)
AC adaptor not connected	Battery charge is above low battery trigger point	<ul style="list-style-type: none"> Operates LED: Battery off DC IN off 	
	Battery charge is below low battery trigger point	<ul style="list-style-type: none"> Operates LED: Battery flashes orange DC IN off 	
	Battery charge is exhausted	Computer goes into resume mode shuts down	
	No battery installed	<ul style="list-style-type: none"> Cannot operate LED: Battery off DC IN off 	

Power indicators

As shown in the above table, the **Battery**, **DC IN** and **Power** indicators on the system indicator alert you to the computer's operating capability and battery charge status.

Battery indicators

Check the **Battery** indicator to determine the status of the battery pack. The following indicator lights indicate the battery status:

Flashing orange	The battery charge is low. The AC adaptor must be connected to recharge the battery.
Orange	Indicates the AC adaptor is connected and charging the battery.
Green	Indicates the AC adaptor is connected and the battery is fully charged.
No light	Under any other conditions, the indicator does not light.



*If the battery pack becomes too hot while it is being charged, the charge will stop and the **Battery** indicator will go out. When the battery pack's temperature falls to a normal range, charge will resume. This occurs whether the computer's power is on or off.*

DC IN indicator

Check the **DC IN** indicator to determine the power status with the AC adaptor connected:

Green	Indicates the AC adaptor is connected and supplying proper power to the computer.
Flashing orange	Indicates a problem with the power supply. Plug the AC adaptor into another power outlet. If it still does not operate properly, contact your dealer.
No light	Under any other conditions, the indicator does not light.

Power indicator

Check the **Power** indicator to determine the power status:

Green	Indicates power is being supplied to the computer and the computer is turned on.
Blinking orange	Indicates power is being supplied to the computer while the computer is in Standby mode. The indicator turns on for one second and off for two seconds.
No light	Under any other conditions, the indicator does not light.

Battery types

The computer has three types of batteries:

- Battery pack
- High capacity battery pack (optional)
- Real Time Clock (RTC) battery

Battery pack

When the AC adaptor is not connected, the computer's main power source is a removable lithium ion battery pack, also referred to in this manual as the main battery. You can purchase additional battery packs for extended use of the computer away from an AC power source.

Before you remove the battery pack, set the computer to Hibernation mode or save your data and shut down the computer. Do not change the battery pack while the AC adaptor is connected.



- *The battery pack is a lithium ion battery, which can explode if not properly replaced, used, handled or disposed of. Dispose of the battery as required by local ordinances or regulations. Use only batteries recommended by TOSHIBA as replacements.*
- *Do not remove the battery pack while the computer is in Standby mode. Data is stored in RAM, so if the computer loses power it will be lost. When the computer is powered off in Standby mode, and the AC adaptor is not connected, the battery pack supply power to maintain data and program in memory. If the battery pack is completely discharged, Standby mode does not function and the computer loses all data in memory.*

To ensure that the battery pack maintains its maximum capacity, operate the computer on battery power at least once a month until the battery pack is fully discharged. Refer to [Extending battery life](#) in this chapter for procedures. If the computer is continuously operated on AC power through an AC adaptor for an extended period, more than a month, the battery may fail to retain a charge. It may not function efficiently over the expected life of the battery and the **Battery** indicator may not indicate a low-battery condition.

High capacity battery pack (optional)

An optional High capacity battery pack is installable instead of a main battery pack. The connection method of High capacity battery pack is the same as that of main battery pack.

- *The battery pack is a lithium ion battery, which can explode if not properly replaced, used, handled or disposed of. Dispose of the battery as required by local ordinances or regulations. Use only batteries recommended by TOSHIBA as replacements.*
- *Do not remove the battery pack while the computer is in Standby mode. Data is stored in RAM, so if the computer loses power it will be lost. When the computer is powered off in Standby mode, and the AC adaptor is not connected, the main battery pack supply power to maintain data and program in memory. If the battery pack is completely discharged, Standby mode does not function and the computer loses all data in memory.*

Real Time Clock (RTC) battery

The Real Time Clock (RTC) battery provides power for the internal real time clock and calendar. It also maintains the system configuration.

If the RTC battery becomes completely discharged, the system loses this data and the real time clock and calendar stop working. The following message appears when you turn on the power:



```
**** RTC battery is low or CMOS checksum is
inconsistent ****
Press [F1] key to set Date/Time.
```

You can change the setting of RTC by pressing **F1** key. Refer to Chapter 9 [Troubleshooting](#) for the detail.



The computer's RTC battery is a lithium ion battery and should be replaced only by your dealer or by a TOSHIBA service representative. The battery can explode if not properly replaced, used, handled or disposed of. Dispose of the battery as required by local ordinances or regulations.

Care and use of the battery pack

The battery pack is a vital component of portable computing. Taking proper care of it will help ensure longer operating time on battery power as well as a longer life for your battery pack. Follow the instructions in this section carefully to ensure safe operation and maximum performance.

Safety precautions

Mishandling of battery packs can cause death, serious injury or property damage. Carefully observe the following advisories:

Danger: Indicates an imminently hazardous situation, which could result in death or serious injury, if you do not follow instructions.

Warning: Indicates a potentially hazardous situation, which could result in death or serious injury, if you do not follow instructions.

Caution: Indicates a potentially hazardous situation, which if not avoided, may result in moderate or minor injury or property damage.

Note: Provides important information.

Danger

1. Never try to dispose of the battery pack by burning or expose it to a heating device such as a microwave oven. The battery pack could explode and cause bodily injury.
2. Never try to disassemble, repair or otherwise tamper with a battery pack. The battery pack will overheat and ignite. Leakage of caustic alkaline solution or other electrolytic substances will cause fire or injury, possibly resulting in death or serious injury.

3. Never short-circuit the battery pack by contacting the terminals with a metal object. A short-circuit can cause fire or otherwise damage the battery pack and possibly cause injury. To avoid accidental short-circuit, always wrap the battery pack in plastic and cover the terminals with electrical tape when storing or disposing of the battery pack.
4. Never puncture the battery pack with a nail or other sharp object. Never strike it with a hammer or other object. Never step on it.
5. Never try to charge the battery pack in any manner other than that described in the user's manual. Never connect the battery pack to a plug socket or to an automobile's cigarette lighter socket. It may rupture or ignite.
6. Use only the battery pack supplied with the computer or other device or a battery pack approved by the computer or device's manufacturer. Battery packs have different voltages and terminal polarities. Use of an improper battery could cause smoke, fire or rupture of the battery pack.
7. Never subject a battery pack to heat, such as storage near a heat source. Exposure to heat can cause the battery pack to ignite, explode or leak caustic liquid and cause death or serious injury. It could also fail or malfunction causing data loss.
8. Never expose the battery pack to abnormal shock, vibration or pressure. The battery pack's internal protective device will fail, causing it to overheat, explode, ignite or leak caustic liquids possibly resulting in death or serious injury.
9. Never let a battery pack become wet. A wet battery pack will overheat, ignite or rupture possibly resulting in death or serious injury.

Warning

1. Never allow caustic electrolyte fluid leaked from a battery pack to contact your eyes, skin or clothing. If caustic electrolyte fluid should contact your eyes, immediately wash your eyes with large amounts of running water and seek medical attention, to help prevent eye damage. If electrolyte fluid should contact your skin immediately wash it under running water to prevent rash. If it contacts your clothes, promptly remove them to prevent the fluid from contacting your skin or eyes.
2. Immediately turn off the power, disconnect the AC adaptor and remove the battery if any of the following events are observed in the battery pack: offensive or unusual odor, excessive heat, discoloration or deformation. Never use the computer again until it has been checked by a TOSHIBA service provider. It might generate smoke or fire, or the battery pack might rupture.
3. Make sure the battery is securely installed in the computer before attempting to charge the battery pack. Improper installation could generate smoke or fire, or cause the battery pack to rupture.
4. Keep the battery pack out of reach of infants and children. It can cause injury.

Caution

1. Never continue to use a battery pack after its recharging capacity has become impaired, or after the display of a warning message indicating that the battery pack's power is exhausted. Continued use of an exhausted or impaired battery pack could cause the loss of data.
2. Never dispose of battery packs with normal trash. Bring them to your TOSHIBA dealer or to another recycling center to save resources and prevent environmental damage. Cover the terminals with electrical tape to prevent short-circuits, which could cause the battery pack to ignite or rupture.
3. Use only battery packs recommended by TOSHIBA as replacements.
4. Always make sure the battery pack is installed correctly and securely. Otherwise, a battery pack could fall out and possibly cause injury.
5. Charge the battery pack only in an ambient temperature between 5 and 35 degrees Celsius. Otherwise, the electrolyte solution might leak, battery pack performance might deteriorate and the battery life might be shortened.
6. Be sure to monitor the remaining battery power. If the battery pack and real time clock battery discharge completely, Standby and Suspend will not function and data in memory will be lost. Also, the computer might register an incorrect time and date. In this case, connect the AC adaptor to recharge the batteries.
7. Never install or remove the battery pack without first turning off the power and disconnecting the AC adaptor. Never remove the battery pack while the computer is in Suspend or Standby mode. Data will be lost.

Note

1. Never remove the battery pack while the Wake-up on LAN function is enabled. Data will be lost. Before you remove a battery pack, disable the Wake-up on LAN function.
2. To ensure the battery pack maintains maximum capacity, operate the computer on battery power once a week until the battery pack is fully discharged. Refer to the section [Extending battery life](#) in this chapter for procedures. If the computer is continuously operated on AC power for an extended period, more than a week, the battery might fail to retain a charge. It might not function efficiently over the expected life of the battery pack and the **Battery** indicator might not indicate a low-battery condition.
3. After the battery pack is charged, avoid leaving the AC adaptor connected and the computer turned off for more than a few hours at a time. Continuing to charge a fully-charged battery pack can damage the battery.

Charging the batteries

When the power in the battery pack becomes low, the **Battery** indicator flashes orange indicating that only a few minutes of battery power remain. If you continue to use the computer while the **Battery** indicator flashes, the computer enables Hibernation mode (so you don't lose data) and automatically turns off.



The computer enters Hibernate mode only if Hibernation is enabled in two places: the Hibernate tab in Power Options and Setup Action tab in TOSHIBA Power Saver.

You must recharge a battery pack when it becomes discharged.

Procedures

To recharge a battery pack while it is installed in the computer, connect the AC adaptor to the DC IN 15V jack and plug the other end into a working outlet.

The **Battery** indicator glows orange when the battery is being charged.



Use only the computer connected to an AC power source or the optional TOSHIBA Battery charger to charge the battery pack. Never attempt to charge the battery pack with any other charger.

Time

The following table shows the approximate time required to fully charge a discharged battery.

Charging time (hours)

Battery type	Power on	Power off
High capacity battery pack (8800mAh)	about 6.0 to 9.0	about 4.5
Battery pack (4700mAh)	about 4.0 to 5.5	about 3.0
RTC battery	8	Doesn't charge



The charging time when the computer is on is affected by ambient temperature, the temperature of the computer and how you use the computer. If you make heavy use of external devices, for example, the battery might scarcely charge at all during operation. Refer also to the section [Maximizing battery operating time](#).

Battery charging notice

The battery may not charge right away under the following conditions:

- The battery is extremely hot or cold. If the battery is extremely hot, it might not charge at all. To ensure the battery charges to its full capacity, charge the battery at room temperature of 10° to 30°C (50° to 88°F).
- The battery is nearly completely discharged. Leave the AC adaptor connected for a few minutes and the battery should begin charging.

The **Battery** indicator may show a rapid decrease in battery operating time when you try to charge a battery under the following conditions:

- The battery has not been used for a long time.
- The battery has completely discharged and been left in the computer for a long time.
- A cool battery is installed in a warm computer.

In such case, follow the steps below.

1. Fully discharge the battery by leaving it in the computer with the power on until the power automatically shuts off.
2. Connect the AC adaptor to the DC IN 15V jack of the computer, and the AC adaptor into power outlet.
3. Charge the battery until the **Battery** indicator glows green.

Repeat these steps two or three times until the battery recovers normal capacity.



Leaving the AC adaptor connected will shorten battery life. At least once a month, run the computer on battery power until the battery is fully discharged, then recharge the battery.

Monitoring battery capacity

Remaining battery power can be monitored in TOSHIBA Power Saver.



- *Wait at least 16 seconds after turning on the computer before trying to monitor the remaining operating time. The computer needs this time to check the battery's remaining capacity and to calculate the remaining operating time, based on the current power consumption rate and remaining battery capacity. The actual remaining operating time may differ slightly from the calculated time.*
- *With repeated discharges and recharges, the battery's capacity will gradually decrease. Therefore, an often used, older battery will not operate for as long as a new battery even when both are fully charged. In this case, TOSHIBA Power Saver will indicate a 100% charge for both the old and new battery, but the displayed estimated time remaining will be shorter for the older battery.*

Maximizing battery operating time

A battery's usefulness depends on how long it can supply power on a single charge.

How long the charge lasts in a battery depends on:

- How you configure the computer (for example, whether you enable battery-power saving options). The computer provides a battery save mode, which can be set in TOSHIBA Power Saver, to conserve battery power. This mode has the following options:
 - CPU Processing speed
 - Screen brightness
 - Cooling Method
 - System standby
 - System Hibernation
 - Monitor Power off
 - HDD Power off
- How often and how long you use the hard disk, optical disc and the floppy disk drive.
- How much charge the battery contained to begin with.
- How you use optional devices, such as a PC card, to which the battery supplies power.
- Enabling Standby mode conserves battery power if you are frequently turning the computer off and on.
- Where you store your programs and data.
- Closing the LCD display panel when you are not using the keyboard saves power.
- Operating time decreases at low temperatures.
- The condition of the battery terminals. Make sure the battery terminals stay clean by wiping them with a clean dry cloth before installing the battery pack.

Retaining data with power off

When you turn off your computer with fully charged batteries, the batteries retain data for the following approximate time periods:

Retention time

Battery type	State and Retention Time
High capacity battery pack (8800mAh)	about 9 days (Standby mode) about 80 days (Power off)
Battery pack (4700mAh)	about 5 days (Standby mode) about 40 days (Power off)
RTC battery	30 days

Extending battery life

To maximize the life of your battery pack:

- At least once a month, disconnect the computer from a power source and operate it on battery power until the battery pack fully discharges. Before doing so, follow the steps below.
 1. Turn off the computer's power.
 2. Disconnect the AC adaptor and turn on the computer's power. If it does not turn on go to step 4.
 3. Operate the computer on battery power for five minutes. If the battery pack has at least five minutes of operating time, continue operating until the battery pack is fully discharged. If the **Battery** indicator flashes or there is some other warning to indicate a low battery, go to step 4.
 4. Connect the AC adaptor to the computer and the power cord to a power outlet. The **DC IN** indicator should glow green, and the **Battery** indicator should glow orange to indicate that the battery pack is being charged. If the **DC IN** indicator does not glow, power is not being supplied. Check the connections for the AC adaptor and power cord.
 5. Charge the battery pack until the **Battery** indicator glows green.
- If you have extra battery packs, rotate their use.
- If you will not be using the system for an extended period, more than one month, remove the battery pack.
- Disconnect the AC adaptor when the battery is fully charged. Overcharging makes the battery hot and shortens life.
- If you are not going to use the computer for more than eight hours, disconnect the AC adaptor.
- Store spare battery packs in a cool dry place out of direct sunlight.

Replacing the battery pack

When the battery pack reaches the end of its operating life you will need to install a new one. The life of the battery pack is generally about 500 recharges. If the **Battery** indicator flashes orange shortly after fully recharging the battery, the battery pack needs to be replaced.

You might also replace a discharged battery pack with a charged spare when you are operating your computer away from an AC power source. This section explains how to remove and install the battery pack.

Removing the battery pack

To replace a discharged battery pack, follow the steps below.



- *When handling battery packs, do not short-circuit the terminals. Also do not drop, hit or otherwise apply impact; do not scratch or break the casing and do not twist or bend the battery pack.*
- *Do not remove the battery pack while the computer is in Standby mode. Data is stored in RAM, so if the computer loses power it will be lost.*
- *In Hibernation mode, data will be lost if you remove the battery pack or disconnect the AC adaptor before the save is completed. Wait for the **HDD** indicator to go out.*
- *Do not touch the battery release latch while holding the computer. Or you may get injured by the dropped battery pack by unintentional release of the battery release latch.*

1. Save your work.
2. Turn the computer's power off. Make sure the **Power** indicator is off.
3. Remove all cables connected to the computer.
4. Close the LCD display panel and turn the computer upside down.
5. Slide the battery lock to unlock position () (left side completely).

- Slide and hold the battery release latch to free the battery pack for removal, then slide out the battery pack.

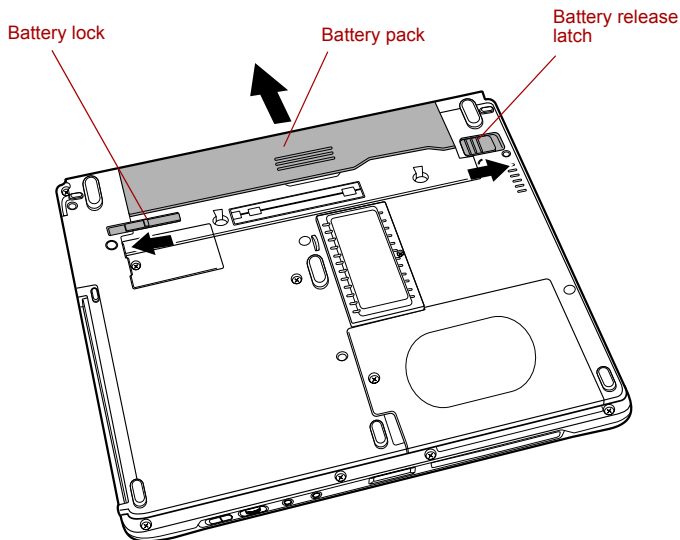

Releasing the battery pack

- Return your computer to the upright position.



For environmental reasons, do not throw away a spent battery pack. Please return spent battery packs to your TOSHIBA dealer.

Installing the battery pack

To install a battery pack, follow the steps below.



- *The battery pack is a lithium ion battery, which can explode if not properly replaced, used, handled or disposed of. Dispose of the battery as required by local ordinances or regulations. Use only batteries recommended by TOSHIBA as replacements.*
- *Do not touch the battery release latch while holding the computer. Or you may get injured by the dropped battery pack by unintentional release of the battery release latch.*

- Turn the computer's power off.
- Disconnect all cables connected to the computer.
- Close the LCD display panel and turn the computer upside down.
- Insert the battery pack.

- Secure the battery pack lock. Check the battery lock was changed to the lock position (🔒).

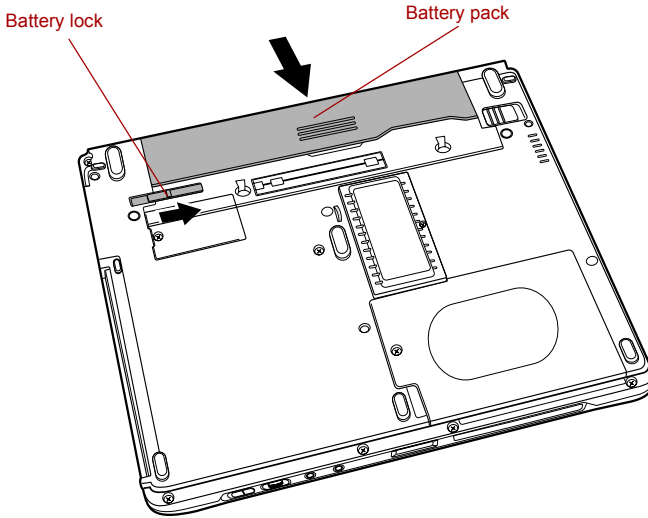

Securing the battery cover

- Return your computer to the upright position.

TOSHIBA Password Utility

The TOSHIBA Password Utility provides two levels of password security: User and Supervisor.



Passwords set in TOSHIBA Password Utility are different from the Windows password.

User password

To start the utility, point to or click the following items:

start -> All Programs -> TOSHIBA -> Utilities -> Password Utility

The user password dialog box contains two main fields: **User Password** and **User Token**.

User authentication may be required to validate user rights when using "TOSHIBA Password Utility" to delete or change passwords, or create tokens, etc.

User Password field

■ Set (button)

Click this button to register a password of up to 50 characters. After a password is set, you will be prompted to enter it when you start the computer.



■ *After you set the password, a dialog box will be displayed asking whether you want to save it to a floppy disk or other media. If you forget the password, you can open the password file on another computer. Be sure to keep the media in a safe place.*

■ *When entering the character string to register the password, enter from the keyboard character by character and do not enter as ASCII code or copy-and-paste the character string. In addition, ensure that the registered password is correct by outputting the character string to the password file.*

■ Delete (button)

Click this button to delete a registered password. Before you can delete a password, you must first enter the current password correctly or insert a proper token.

■ Change (button)

Click this button to change a registered password. Before you can change a password, you must first enter the current password correctly or insert a proper token.

■ Owner String (text box)

You can use this box to associate text with the password. After you enter text, click **Apply** or **OK**. At the time of a startup of a computer, this text is displayed, when you can ask for the input of a password.

User Token field

■ Create (button)

You can use an SD card token, instead of entering the password. After you have registered a password, insert an SD card in SD card slot and click **Create**. You can use an SD card of any capacity, but it must be formatted correctly.

If an unformatted card or one with an incompatible format is inserted, you will be prompted to format it with a tool named TOSHIBA SD Memory Card Format. To start the format tool, point to or click the following items:

start -> All Programs -> TOSHIBA -> Utilities -> SD Memory Card Format



When you format an SD Memory card, all data will be deleted. Be sure to save data on the card to other media before you format the card.

■ **Disable** (button)

Click this button to invalidate the token. You cannot revalidate old tokens, but you can use the same SD cards to create new tokens.



After using the token created for authentication, do not leave it inserted in the SD card slot, ensure that the token is removed from the slot and stored in a safe location. If the token is left in the slot, there is a danger of theft or a third party using it for authentication and operating the user's computer (resulting in extraction, modification or deletion of data) when the user is not at their desk.

Supervisor password

If you set a supervisor password, some functions might be restricted when a user logs on with the user password. To set a supervisor password, execute the file TOSPU.EXE. The file is located at:

```
C:\Program Files\Toshiba\Windows  
Utilities\SVPWTool\TOSPU.EXE
```

This utility lets you do the following:

- Register, delete or change the supervisor password.
- Create or invalidate a supervisor password token.



This function in the TOSHIBA Password Utility lets you invalidate only supervisor tokens.

- Specify restrictions for general users.

Starting the computer by password

If you registered a password, there are two ways to start the computer:

- Insert an SD card token before you turn on the computer. The computer will start normally, without displaying a password prompt.
- Enter the password manually.



The password is necessary only if the computer was shut down in boot mode. It is not needed in Standby mode.

To enter a password manually, follow these steps:

1. Turn on the power as described in Chapter 3, [Getting Started](#). The following message will appear in the LCD:



Password=

2. Enter the Password.
3. Press **Enter**.



If you enter the password incorrectly three times in a row, the computer shuts off. In this case, you must turn the computer back on to retry password entry.

Power-up modes

The computer has the following power-up modes:

- **Boot:** Computer shuts down without saving data. Always save your work before you turn the computer off in boot mode.
- **Hibernation:** Data in memory is saved to the hard disk.
- **Standby:** Data is maintained in the computer's memory.



Refer also to the sections [Turning on the power](#) and [Turning off the power](#) in Chapter 3, [Getting Started](#).

Windows utilities

You can specify the setting in TOSHIBA Power Saver.

Hot keys

You can use hot keys **Fn + F3** to enter Standby mode and **Fn + F4** to enter Hibernation. Refer to Chapter 5, [The Keyboard](#) for details.

Panel power on/off

You can set up your computer so that power turns off automatically when you close the computer's LCD display panel. When you open the computer's LCD display panel, power turns on in Standby or Hibernation mode but not in boot mode.



If the panel power off function is enabled and you use Shut down Windows, do not close the computer's LCD display panel until the shut down function is completed.

System Auto Off

This feature turns the system off automatically if it is not used for a set duration. The system shuts down in Standby mode or Hibernation mode in Windows.

HW Setup

This chapter explains how to use TOSHIBA HW Setup program to configure your computer. TOSHIBA HW Setup lets you configure settings for General, Display, Boot Priority, Keyboard, CPU, LAN, Device Config, Parallel/Printer and USB.

Accessing HW Setup

To run HW Setup, click **start**, click **Control Panel**, click **Printers and Other Hardware** and select **TOSHIBA HWSetup**.

HW Setup window

The HW Setup window contains the following tabs: General, Display, Boot Priority, Keyboard, CPU, LAN, Device Config, Parallel/Printer and USB.

There are also three buttons: **OK**, **Cancel** and **Apply**.

OK	Accepts your changes and closes the HW Setup window.
Cancel	Closes the window without accepting your changes.
Apply	Accepts all your changes without closing the HW Setup window.

General

This window displays the BIOS version and contains two buttons: **Default** and **About**.

Default	Return all HW Setup values to the factory settings.
About	Display the HW Setup version.

Setup

This field displays BIOS **Version** and date.

Display

This tab lets you customize your computer's display settings for either the internal LCD screen or for an external monitor.

Power On Display

Lets you use the display to be used when the computer is booted. (This setting is only available on Standard VGA mode and not available on Windows Desktop)

Auto-Selected	Selects an external monitor if one is connected. Otherwise, it selects the internal LCD (Default).
LCD + Analog RGB	Selects both the internal LCD and external monitor for simultaneous display.



If the connected external monitor does not support the SVGA mode, selecting the LCD + Analog RGB mode will not display the screen on that monitor.

At Windows start-up, the screen is displayed on the external monitor if it was connected at the time of the previous power-off, and is found at the start-up. Otherwise, the screen is displayed on the internal LCD.

Boot Priority

Boot Priority Options

This option sets the priority for booting the computer. Select from the following settings:

HDD -> FDD -> CD-ROM -> LAN	The looks for bootable files in the following order: HDD, floppy disk drive*1, CD-ROM*2 and LAN (Default).
FDD -> HDD -> CD-ROM -> LAN	The computer looks for bootable files in the following order: floppy disk drive*1, HDD, CD-ROM*2 and LAN.

HDD → FDD → CD-ROM → LAN	The looks for bootable files in the following order: HDD, floppy disk drive*1, CD-ROM*2 and LAN (Default).
HDD → CD-ROM → LAN → FDD	The computer looks for bootable files in the following order: HDD, CD-ROM*2, LAN and floppy disk drive*1.
FDD → CD-ROM → LAN → HDD	The computer looks for bootable files in the following order: floppy disk drive*1, CD-ROM*2, LAN and HDD.
CD-ROM → LAN → HDD → FDD	The computer looks for bootable files in the following order: CD-ROM*2, LAN, HDD, floppy disk drive*1.
CD-ROM → LAN → FDD → HDD	The computer looks for bootable files in the following order: CD-ROM*2, LAN, floppy disk drive*1 and HDD.

You can override the settings and manually select a boot device by pressing one of the following keys while the computer is booting:

U	Selects the USB floppy disk drive.
N	Selects the Network.
1	Selects the primary HDD.
C	Selects the CD-ROM*2.

*1 FDD is looked for when the boot disk is contained in external FDD. When SD memory card is set as the boot disk, external FDD is looked for first. Next, SD memory card is looked for.

*2 In this computer, CD-ROM refers to the Fixed optical media drive.

To change the boot drive, follow the steps below.

1. Hold down **F12** and boot the computer.
2. The following menu will be displayed with the following icons: Built-in HDD, CD-ROM, FDD (or SD memory card), Network (LAN) boot.



A bar will appear only under the selected device.

3. Use the left/right cursor keys to highlight the boot device you want and press **Enter**.



- *If a supervisor password is set only, it is the following.*
 - *The menu above appear when you use the user password to start the computer (able to run HW Setup).*
 - *The menu above does not appear when you use the user password to start the computer (unable to run HW Setup).*
- *If the supervisor and user password are set, it is the following.*
 - *The menu above appear when you use the supervisor and user password to start the computer (able to run HW Setup).*
 - *The menu above does not appear when you use the user password to start the computer (unable to run HW Setup).*
 - *The menu above appear when you use the supervisor password to start the computer (unable to run HW Setup).*
- *The selection method above does not change the boot priority settings in HW Setup.*
- *If you press a key other than one of those above or if the selected device is not installed, the system will boot according to the current setting in HW Setup.*

Network Boot Protocol

This feature sets the protocol to remotely boot from the network.

- [PXE] Sets PXE as the protocol (Default).
- [RPL] Sets RPL as the protocol.

Keyboard

External Keyboard Fn key

Use this option to set a key combination on an external keyboard to emulate the **Fn** key on the computer's internal keyboard. Setting an **Fn** key equivalent will let you use Hot keys by pressing the set combination instead of the **Fn** key (PS/2 keyboard only).

Disabled	No Fn key equivalent (Default).	
Fn Equivalent	Left Ctrl	+ Left Alt
	Right Ctrl	+ Right Alt
	Left Alt	+ Left Shift
	Right Alt	+ Right Shift
	Left Alt	+ Caps Lock



If you select **Left Ctrl + Left Alt** or **Right Ctrl + Right Alt** for this option, you cannot use the selected keys to reboot the computer in combination with the **Del** key. For example, if you select **Left Ctrl + Left Alt**, you must use **Right Ctrl, Right Alt** and **Del** to reboot the computer. **Left Ctrl, Left Alt** and **Del** cannot be used.

Wake-up on Keyboard

When this feature is enabled and the computer is in Standby mode, you can turn on the computer by pressing any key. It is effective only for the internal keyboard and only when the computer is in standby mode.

Enabled	Enables the Wake-up on Keyboard.
Disabled	Disables the Wake-up on Keyboard (Default).

CPU

This function lets you set the CPU operating mode.



It is displayed in Pentium-M[®] model only.

Dynamic CPU Frequency Mode

This option lets you choose from the following settings:

Dynamically Switchable	CPU power consumption and clock speed automatic switching function is enabled. When the computer is in use, CPU operation is automatically switched when necessary (Default).
Always High	CPU power consumption and clock speed automatic switching function is disabled. The CPU always runs at its fastest speed.
Always Low	CPU power consumption and clock speed automatic switching function is disabled. The CPU always runs at low power consumption and low speed.

LAN

Wake-up on LAN

This feature lets the computer's power be turned on when it receives a wake-up signal from the LAN.

Enabled	Enables Wake-up on LAN.
Disabled	Disables Wake-up on LAN. (Default)



Do not install or remove an optional memory module while Wake-up on LAN is enabled.



The Wake-up on LAN function consumes power even when the system is off. Leave the AC adaptor connected while using this feature.

Built-in LAN

This feature enables or disables the Built-in LAN.

Enabled	Enables Built-in LAN functions (Default).
Disabled	Disables Built-in LAN functions.

Device Config

Device Configuration

This option lets you set the device configuration.

All Devices	BIOS sets all devices.
Setup by OS	Operating system sets devices that it can control (Default).

Parallel/Printer



This setup can be used only when Advanced Port Replicator III is connected.

Some models are equipped with Parallel/Printer tab. This tab lets you set the Parallel Port Mode. Use the Windows Device Manager to make settings for the Parallel port.

Parallel Port Mode

The options in this tab are **ECP** and **Standard Bi-directional**.

ECP	Sets the port type to Extended Capabilities Port (ECP). For most printers, the port should be set to ECP (Default).
Standard Bi-directional	This setting should be used with some other parallel devices.

USB

USB KB/Mouse Legacy Emulation

Use this option to enable or disable USB KB/Mouse Legacy Emulation. If your operating system does not support USB, you can still use a USB mouse and keyboard by setting the **USB KB/Mouse Legacy Emulation** item to **Enabled**.

Enabled	Enables the USB KB/Mouse Legacy Emulation (Default).
Disabled	Disables the USB KB/Mouse Legacy Emulation.

USB-FDD Legacy Emulation

Use this option to enable or disable USB-FDD Legacy Emulation.

Enabled	Enables the USB-FDD Legacy Emulation (Default).
Disabled	Disables the USB-FDD Legacy Emulation.

Optional Devices

Optional devices can expand the computer's capabilities and its versatility. This chapter describes connection or installation of the following devices, which are available from your TOSHIBA dealer:

Cards/memory

- PC card
- SD card
- CF (CompactFlash) card
- Memory expansion

Power devices

- Battery pack
- AC adaptor
- Battery charger

Peripheral devices

- USB floppy disk drive
- External monitor
- i.LINK (IEEE1394)
- Advanced Port Replicator III
- Parallel Printer (via Advanced Port Replicator III)

Other

- Security lock

PC card

The computer is equipped with a PC card slot that can accommodate a Type II card. Any PC card that meets industry standards (manufactured by TOSHIBA or other vendor) can be installed. The slot supports 16-bit PC cards, including PC card 16's multifunction card and CardBus PC cards.

CardBus supports the new standard of 32-bit PC cards. The bus provides superior performance for the greater demands of multimedia data transmission.

Inserting a PC card

The PC card slot is located on the left side of the computer.

Windows hot-install feature lets you insert PC cards while the computer's power is on.



Do not insert a PC card while the computer is in standby or hibernation mode. Some cards might not work properly.

To insert a PC card, follow the steps below:

1. Insert a PC card in the PC card slot.
2. Press gently to ensure a firm connection.

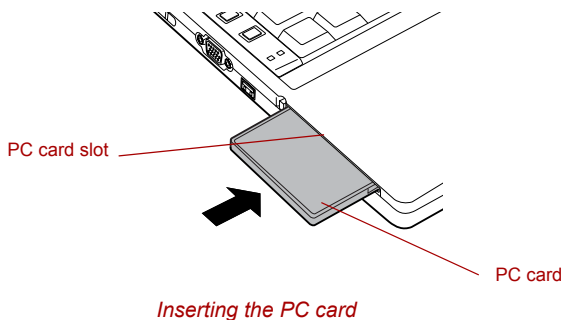

3. After inserting the PC card, refer to the PC card's documentation and check the configuration in Windows to make sure it is appropriate for your PC card.

Removing a PC card

To remove the PC card, follow the steps below.

1. Open the **Safely Remove Hardware** icon on the Task Bar.
2. Point to **PC card** and click.
3. Press the PC card eject button to extend it.



If the PC card is not inserted all the way, the eject button may not pop out. Be sure to push the PC card firmly and press the eject button again.

4. Press the extended eject button to pop the card out slightly.

5. Grasp the PC card and draw it out.

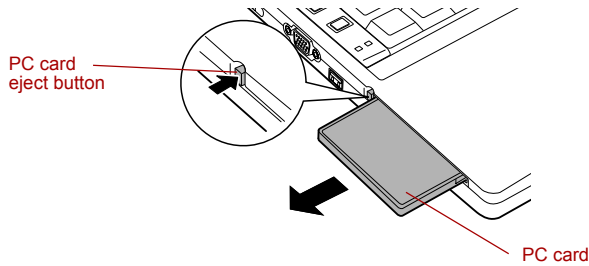

Removing the PC card

SD card

The computer is equipped with an SD card slot that can accommodate Secure Digital flash memory cards with various memory capacities. SD cards let you easily transfer data from devices, such as digital cameras and Personal Digital Assistants, that use SD card flash-memory. The cards have a high level of security and copy protection features. The slot cannot accommodate Multi Media cards.



Keep foreign objects out of the SD card slot. A pin or similar object can damage the computer's circuitry.



SD memory cards comply with SDMI (Secure Digital Music Initiative), which is a technology adopted to prevent unlawful copy or playback of digital music. For this reason, you cannot copy or playback protected material on another computer or other device. You may not use the reproduction of any copyrighted material except for your personal enjoyment.

Formatting an SD memory card

SD memory cards are sold with format in conformity to the Standards of SD memory card. If you format the SD card again, be sure to format it with the utility of TOSHIBA SD memory card format, not in the format defined as the Windows standard format.

In order to run TOSHIBA SD memory card format, click **start**, point to **All Programs**, point to **TOSHIBA**, point to **Utilities** and click **SD memory card Format**.

TOSHIBA SD memory card format does not format the protected area of SD memory card. When you format all area of the SD memory card including the protected area, use the application that responds to the copy protection system.

Inserting an SD card

To insert an SD card, follow the steps below.

1. Insert an SD card in the SD card slot.
2. Press gently to ensure a firm connection.

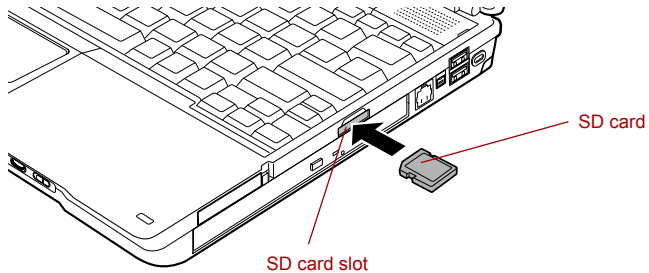

Inserting an SD card



Make sure the SD card is oriented properly before you insert it.

Removing an SD card

To remove an SD card, follow the steps below.

1. Open the **Safely Remove Hardware** icon on the Task Bar.
2. Point to **SD card** and click.
3. Push in the SD card and release it to pop the card out slightly.
4. Grasp the SD card and remove it.

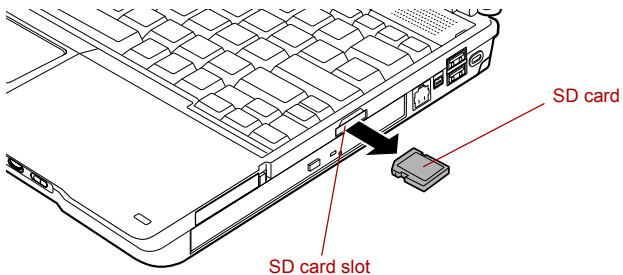

Removing an SD card



- *Make sure the **SD card** indicator is out before you remove the SD card or turn off the computer's power. If you remove the card or turn off the power while the computer is accessing the card you may lose data or damage the card.*
- *Do not remove an SD card while the computer is in Standby or Hibernation mode. The computer could become unstable or data in the SD card could be lost.*

SD card care



Set the write-protect switch to the lock position, if you do not want to record data.

1. Do not write to an SD card if the battery power is low. Low power could affect writing accuracy.
2. Do not remove an SD card while read/write is in progress.
3. The SD card is designed so that it can be inserted only one way. Do not try to force the SD card into the SD card slot.
4. Do not leave an SD card partially inserted in the slot. Press the SD card until you hear it click into place.
5. Do not twist or bend SD cards.
6. Do not expose SD cards to liquids or store in humid areas or lay media close to containers of liquid.
7. After using an SD card, return it to its case.
8. Do not touch the metal part or expose it to liquids or let it get dirty.

Creation of a boot disk

In TOSHIBA SD Memory Boot Utility, a boot disk can be created with SD memory card. Refer to the [Utilities](#) of Chapter 1, Introduction for details.

CF (CompactFlash) card

This slot accommodates CF card. You cannot use CF card that does not conform to CF card Association specifications.



- *Do not turn off the power or remove or reinsert a card while data is being written or read. Data could be destroyed. Wait for the indicator to go out.*
- *Do not touch the card's connector. You could expose the storage area to static electricity, which can destroy data.*
- *Hold the card straight when you insert or remove it.*
- *Pull the card completely out when you remove it. Do not leave it partially inserted.*

Inserting a CF card

To insert a CF card, follow the steps below.

1. Press the CF card eject button to extend it.
2. Press the extended eject button to pop the Dummy card out slightly.
3. Insert the CF card into the slot.
4. Press gently to ensure a firm connection.

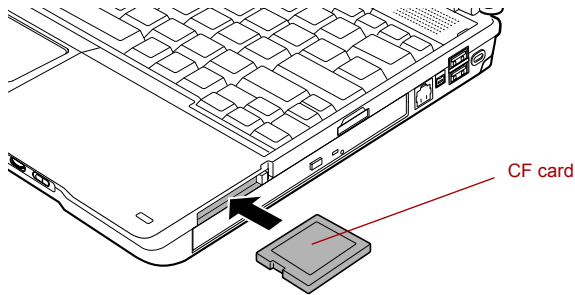

Inserting a CF card

Removing a CF card

To remove a CF card, follow the steps below.

1. Open the **Safely Remove Hardware** icon on the Task Bar.
2. Point to **CF card** and click.
3. Press the CF card eject button to extend it.
4. Press the extended eject button to pop the CF card out slightly.
5. Grasp the CF card and pull out.

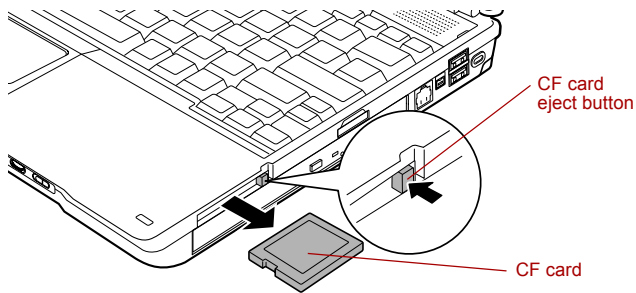

Removing a CF card



Make sure the indicator is out before you remove the CF card or turn off the computer's power. If you remove the CF card or turn off the power while the computer is accessing the CF card you may lose data or damage the CF card.

CF card care

1. CF card used is consumable items, so make sure you back up important data.
2. Do not twist or bend CF card.
3. Do not expose CF card to liquids or store in humid areas or lay media close to containers of liquid.
4. Do not touch the metal part of a CF card or expose it to liquids or let it get dirty.
5. After using CF card, return it to its case.



For more details on using CF card, see manuals accompanying the card.

Memory expansion

This computer has equipped the underside one memory module socket. You can increase the capacity of RAM by installing an additional memory or replacing default memories with additional memories.



- *Place a mat beneath the computer to prevent making a scratch on the lid when replacing the memory module. Avoid the mat that generates static electricity.*
- *When you remove a memory, please do not touch other portions of a computer.*



- *Use only memory modules approved by TOSHIBA.*
- *Do not try to install or remove a memory module under the following conditions. You can damage the computer and the module. Also, data will be lost.*
 - a. The computer is turned on.
 - b. The computer was shut down using the Standby mode or Hibernation mode.
 - c. Wake-up on LAN is enabled.
- *Be careful not to let screws or other foreign matter fall into the computer. It could cause malfunction or electric shock.*
- *Expansion memory is a precision electronic component that may be fatally damaged by static electricity. Since human body has slight static electricity, be sure to discharge static electricity from your body before installing an expansion memory module. To discharge your body's static electricity, simply touch any metal close to you with bare hands.*

Some memory modules can be physically installed but are not compatible with the computer. In this case, the computer will issue a warning. When you turn on the power, a series of short beeps will sound in the pattern of one, three, three, one. Shut down the power and remove the incompatible module.



Use a point size 0 Phillips screwdriver to remove and fasten the screws. Use of an incorrect screwdriver can damage the screw heads.

Installing memory module

Follow the steps below to install a memory module.

1. Set the computer to boot mode and turn the computer's power off. Make sure the **Power** indicator is off.
2. Remove AC adaptor and all cables connected to the computer.
3. Turn the computer upside down and remove the battery pack. Refer to [Replacing the battery pack](#) section in Chapter 6, Power and Power-Up Modes, for details.
4. Loosen a screw securing the memory module cover. The screw is attached to the cover to prevent it from being lost.
5. Slide your fingernail or a thin object under the cover and lift it off.

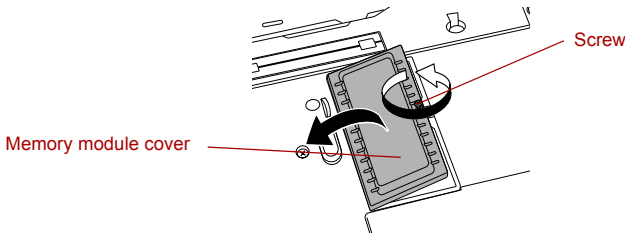

Removing the memory module cover

6. Fit the memory module's connectors into the socket at about a 45 degree angle and push the module down until latches on either side snap into place. Align the notch of the memory module with that of the memory slot and gently insert the module into the slot.

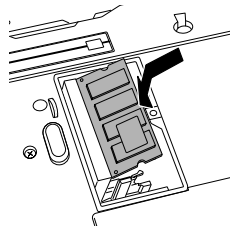

Seating the memory module



Align the grooves of the memory module with the locking tabs of the connector and insert the module into the connector firmly. If you find it difficult to install the memory module, try to adjust the tabs of the connector with a pen tip or other tools. Make sure to hold the memory module with your fingers on the side edges (sides with grooves).



- *Be careful not to drop the screw inside the computer.*
- *Do not touch the connectors on the memory module or on the computer. Debris on the connectors may cause memory access problems.*

7. Seat the memory module cover and secure it with one screw.
8. Install the battery pack. Refer to [Replacing the battery pack](#) section in Chapter 6, Power and Power-Up Modes, for details.
9. Return your computer to the upright position.
10. Turn the computer power on and make sure the added memory is recognized. Open **System Properties** in the Control Panel and click the **General** tab.

Removing memory module

To remove the memory module, make sure the computer is in boot mode then:

1. Set the computer to boot mode and turn the computer's power off. Make sure the **Power** indicator is off.
2. Remove AC adaptor and all cables connected to the computer.
3. Turn the computer upside down and remove the battery pack. Refer to [Replacing the battery pack](#) section in Chapter 6, Power and Power-Up Modes, for details.
4. Loosen a screw securing the memory module cover. The screw is attached to the cover to prevent it from being lost.



Be sure that the cover is closed firmly.

5. Slide your fingernail or a thin object under the cover and lift it off.
6. Push the latches to the outside to release the module. A spring will force one end of the module up.

7. Grasp the module by the sides and pull it out.



- *If you use the computer for a long time, the memory modules and the circuits located close to the memory modules will become hot. In this case, let them cool to room temperature before you replace them.*
- *Do not touch the connectors on the memory module or on the computer. Debris on the connectors may cause memory access problems.*

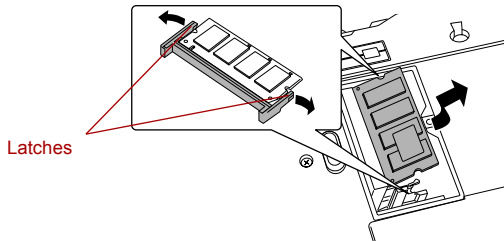

Removing the memory module

8. Seat the memory module cover and secure it with one screw.
9. Install the battery pack. Refer to [Replacing the battery pack](#) section in Chapter 6, Power and Power-Up Modes, for details.
10. Return your computer to the upright position.

Battery pack

You can increase the portability of the computer with additional battery packs. If you're away from an AC power source and your battery runs low, you can replace it with a freshly charged battery. Refer to Chapter 6, [Power and Power-Up Modes](#).

AC adaptor

If you frequently transport the computer between different sites such as your home and office, purchasing an AC adaptor for each location will reduce the weight and bulk of your carrying load.

Battery charger

The battery charger provides a convenient way to charge battery packs without requiring the use of your computer. The battery charger holds up to two battery packs (lithium ion).

USB floppy disk drive

The USB floppy disk drive module can be connected to the USB port. For details on connecting the USB floppy disk drive module, refer to Chapter 4, *Operating Basics*.

External monitor

An external analog monitor can be connected to the external monitor port on the computer. The computer supports VGA and XGA video modes. To connect a monitor, follow the steps below.

1. Turn the computer's power off.
2. Connect the monitor cable to the external monitor port.

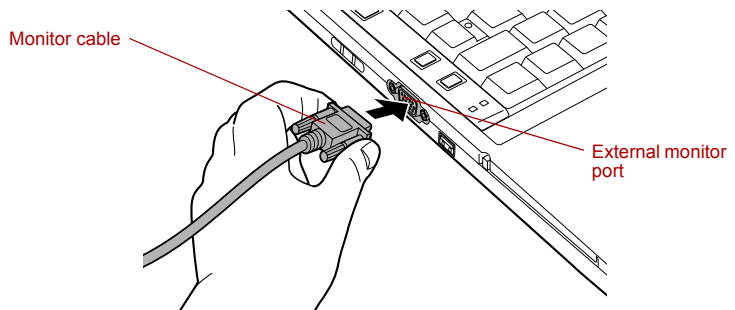

Connecting the monitor cable to the external monitor port

3. Turn the monitor's power on.
4. Turn the computer's power on.

When you turn on the power, the computer automatically recognizes the monitor and determines whether it is color or monochrome.

However, the Windows Desktop appears on a display device that you used last time to shut down your computer, if the display device exists when you turn on the power.

To change the display settings, press **Fn + F5**. If you disconnect the external monitor before you turn the computer's power off, be sure to press **Fn + F5** to switch to the internal display. Refer to Chapter 5, *The Keyboard*, for details on using hot keys to change the display setting.

i.LINK (IEEE1394)

i.LINK (IEEE1394) is used for high-speed data transfer for a range of compatible devices such as

- Digital video cameras
- Hard disk drives
- MO drives
- CD-RW drives



i.LINK uses a four-pin connector, which does not carry electric current. External devices will need their own power supply.

Precautions

- Make a back-up of your data before transferring it to the computer. There is a possibility that the original data will be damaged. There is a particular risk that some frames will be deleted in the case of digital video transfer. TOSHIBA assumes no liability for such loss of data.
- Do not transfer data in areas where static electricity is easily generated or in areas subjected to electronic noise. Data can be destroyed.
- If you are transferring data through an IEEE1394 hub, do not connect or disconnect other devices from the hub during data transfer. There is a likelihood that data will be damaged. Connect all devices to the hub before you turn on the computer's power.
- You may not use any copyrighted video or music data copied from a video camera except for your personal enjoyment.
- If you connect/disconnect an i.LINK device to/from another i.LINK device that is currently exchanging data with the computer, data frames might be dropped.
- Make sure data transfer has ended or turn off the computer, before you:
 - Connect/disconnect an i.LINK device to/from the computer.
 - Connect/disconnect an i.LINK device to/from another i.LINK device that is connected to the computer.

Connecting

1. Make sure the connectors are properly aligned and plug the i.LINK (IEEE1394) cable into the computer.

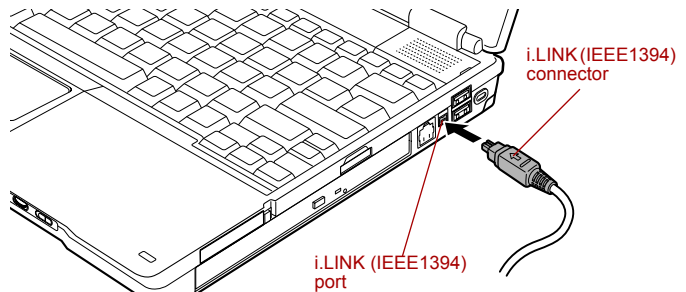

Connecting the i.LINK(IEEE1394) cable into the computer

2. Plug the other end of the cable into the device.

Note the following when you use i.LINK:

- You may need to install drivers for your i.LINK devices.
- Not all i.LINK devices have been tested. Therefore, compatibility with all i.LINK devices cannot be guaranteed.
- Use i.LINK (IEEE1394) cable no longer than three meters.
- Some devices might not support standby or automatic off functions.
- Do not connect or disconnect an i.LINK device while it is using an application or when the computer is automatically shutting it down to save power. Data might be destroyed.

Disconnecting

1. Open the **Safely Remove Hardware** icon on the Task Bar.
2. Point to **i.LINK (IEEE1394) device** and click.
3. Disconnect the cable from the computer then from the i.LINK device.



Refer also to the documentation that came with your i.LINK device.

Advanced Port Replicator III

In addition to the ports available on the computer, the Advanced Port Replicator III provides serial port and separate ports for PS/2 mouse and PS/2 keyboard. The Advanced Port Replicator connects directly to the docking interface on the underside of the computer. The AC adaptor connects the Advanced Port Replicator to a power source.



The computer must be configured properly before connecting to a LAN. Logging onto a LAN using the computer's default settings could cause a malfunction in LAN operation. Check with your LAN administrator regarding set-up procedures.



- *You must connect the AC adaptor before you connect to an Advanced Port Replicator III.*
- *When an Advanced Port Replicator III is connected to the computer, you can not use the following computer's ports: Modem jack, LAN jack, External monitor port.*
- *The PORTÉGÉ M300 does not support the DVI and i.LINK ports on the Advanced Port Replicator III.*

The following ports and accessories are available on the Advanced Port Replicator III.

- RJ45 LAN jack
- RJ11 Modem jack
- External monitor port
- Parallel port
- Serial port
- PS/2 mouse port
- PS/2 keyboard port
- DC IN 15V jack
- Security lock slot
- Audio line-in, line-out jacks
- Universal Serial Bus 2.0 port (four)
- i.LINK (IEEE 1394) port (This port is not supported by the computer).
- DVI port (This port is not supported by the computer).

Parallel printer



A parallel printer port can be used only when Advanced Port Replicator III is connected.

You can connect any standard Centronics-compatible parallel printer to your computer. All you need is an IBM PC™ parallel printer cable. Your dealer can supply one or you can purchase one at most computer stores.

The cable's connectors are designed so that it is impossible for you to connect them incorrectly. To connect a printer, follow these steps:

1. Turn off the computer's power.
2. Connect the cable into the Advanced Port Replicator III's parallel port.
3. Tighten the screws that fasten the connector to the Advanced Port Replicator III's parallel port.
4. Connect the other connector of the cable into the printer's parallel connector.
5. Fasten the connector to the printer with the clips on the parallel port.
6. Turn on the printer's power.
7. Turn on the computer's power.
8. Start the HW Setup program. Refer to Chapter 7, *HW Setup*.
9. Select the **Parallel/Printer** tab from the **TOSHIBA HW Setup** window.
10. Set the **Parallel Port Mode** and press **OK**.
11. Choose **Reboot** for the change to take effect.
12. Select the printer in Windows Add Print Wizard. To access the **Add Print Wizard** utility, click **start**, click **Control Panel**, click **Printers and Other Hardware** and select the **Add Printer**.

Security lock

Security locks enable you to anchor your computer and optional Advanced Port Replicator III to a desk or other heavy object to help prevent unauthorized removal of the computer or Advanced Port Replicator III.

The computer has a security lock slot on the left side and right side. Attach one end of a cable to a desk and the other end to the security lock slot.

1. Turn the computer so the left side (or right side) faces you.
2. Align the holes for the security lock and attach the lock.

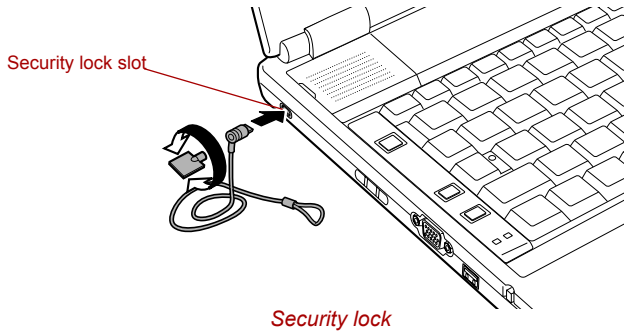

Troubleshooting

TOSHIBA designed the computer for durability. However, should problems occur, following the procedures in this chapter can help to determine the cause.

All readers should become familiar with this chapter. Knowing what might go wrong can help prevent problems from occurring.

Problem solving process

Resolving problems will be much easier if you observe the following guidelines:

- Stop immediately when you recognize a problem exists. Further action may result in data loss or damage. You may destroy valuable problem-related information that can help solve the problem.
- Observe what is happening. Write down what the system is doing and what actions you performed immediately before the problem occurred. If you have a printer attached, print a copy of the screen using **PrtSc**.

The questions and procedures offered in this chapter are meant as a guide, they are not definitive problem solving techniques. Many problems can be solved simply, but a few may require help from your dealer. If you find you need to consult your dealer or others, be prepared to describe the problem in as much detail as possible.

Preliminary checklist

Consider the simplest solution first. The items in this checklist are easy to fix and yet can cause what appears to be a serious problem.

- Make sure you turn on all peripheral devices before you turn on the computer. This includes your printer and any other external device you are using.
- Before you attach an external device, turn the computer off. When you turn the computer back on it recognizes the new device.
- Make sure all options are set properly in the setup program.
- Check all cables. Are they correctly and firmly attached? Loose cables can cause signal errors.
- Inspect all connecting cables for loose wires and all connectors for loose pins.
- Check that your floppy disk or CD/DVD-ROM is correctly inserted and that the floppy disk's write protect tab is correctly set.

Make notes of your observations and keep them in a permanent error log. This will help you describe your problems to your dealer. If a problem recurs, the log will help you identify the problem faster.

Analyzing the problem

Sometimes the system gives clues that can help you identify why it is malfunctioning. Keep the following questions in mind:

- Which part of the system is not operating properly: keyboard, floppy disk drives, hard disk drive, optical media drive, display. Each device produces different symptoms.
- Is the operating system configuration set properly? Check the configuration options.
- What appears on the display screen? Does it display any messages or random characters? If you have a printer attached, print a copy of the screen using **PrtSc**. Look up the messages in the software and operating system documentation. Check that all connecting cables are correctly and firmly attached. Loose cables can cause erroneous or intermittent signals.
- Do any indicators light? Which ones? What color are they? Do they stay on or blink? Write down what you see.
- Do you hear any beeps? How many? Are they long or short? Are they high pitched or low? Is the computer making any unusual noises? Write down what you hear.

Record your observations so you can describe them to your dealer.

Software	<p>The problems may be caused by your software or disk. If you cannot load a software package, the media may be damaged or the program might be corrupted. Try loading another copy of the software.</p> <p>If an error message appears while you are using a software package, check the software documentation. These documents usually include a problem solving section or a summary of error messages.</p> <p>Next, check any error messages in the OS documentation.</p>
Hardware	<p>If you cannot find a software problem, check your hardware. First run through the items in the preliminary checklist above. If you still cannot correct the problem, try to identify the source. The next section provides checklists for individual components and peripherals.</p>

Hardware and system checklist

This section discusses problems caused by your computer's hardware or attached peripherals. Basic problems may occur in the following areas:

- System start-up
- Self test
- Power
- Password
- Keyboard
- Internal LCD display panel
- Hard disk drive
- DVD-ROM&CD-R/RW drive
- DVD Super Multi drive
- USB floppy disk drive
- SD card
- PC card
- CF Card
- Infrared port
- Pointing device
- USB
- Memory expansion
- Sound system
- External monitor
- i.LINK (IEEE1394)
- Modem
- LAN
- Wireless LAN
- Bluetooth
- Printer

System start-up

When the computer does not start properly, check the following items:

- Self Test
- Power Sources
- Power-on Password

Self test

When the computer starts up, the self test will be run automatically, and the following will be displayed:



In Touch with Tomorrow
TOSHIBA

This message remains on the screen for a few seconds.

If the self test is successful, the computer tries to load the operating system, depending on how the Boot Priority is set in the TOSHIBA HW Setup program.

If any of the following conditions are present, the self test failed:

- The computer stops and does not proceed to display information or messages except the TOSHIBA logo.
- Random characters appear on the screen, and the system does not function normally.
- The screen displays an error message.

Turn off the computer and check all cable connections. If the test fails again, contact your dealer.

Power

When the computer is not plugged into an AC outlet, the battery pack is the primary power source. However, your computer has a number of other power resources, including intelligent power supply, Real Time Clock battery. These resources are interrelated and any one could affect apparent power problems. This section provides checklists for AC power and the battery. If you cannot resolve a problem after following them, the cause could lie with another power resource. In such case, contact your dealer.

Overheating power down

If the computer's internal temperature becomes too high, the computer will automatically enter Hibernation or Resume mode and shut down.

Problem	Procedure
Computer shuts down and DC IN indicator blinks orange	Leave the computer off until the DC IN indicator stops blinking.



*It is recommended to leave the computer off until the its interior reaches room temperature even though the **DC IN** indicator stops blinking.*

If the computer has reached room temperature and still does not start, or if it starts but shuts down quickly contact your dealer.

Computer shuts down and its DC IN indicator is flashing in green	Indicates a problem with the heat dispersal system. Please contact your dealer.
-------------------------------------------------------------------------	---------------------------------------------------------------------------------

AC power

If you have trouble turning on the computer with the AC adaptor connected, check the **DC IN** indicator. Refer to Chapter 6, *Power and Power-Up Modes* for more information.

Problem	Procedure
AC adaptor doesn't power the computer (DC IN indicator does not glow green)	<p>Check the connections. Make sure the cord is firmly connected to the computer and a power outlet.</p> <hr/> <p>Check the condition of the cord and terminals. If the cord is frayed or damaged, replace it. If the terminals are soiled, wipe them with cotton or a clean cloth.</p> <hr/> <p>If the AC adaptor still does not power the computer, contact your dealer.</p>

Battery

If you suspect a problem with the battery, check the **DC IN** indicator as well as the **Battery** indicator. For information on indicators and battery operation see Chapter 6, *Power and Power-Up Modes* .

Problem	Procedure
Battery doesn't power the computer	The battery may be discharged. Connect the AC adaptor to charge the battery.

Problem	Procedure
<p>Battery doesn't charge when the AC adaptor is attached (Battery indicator does not glow in orange.)</p>	<p>If the battery is completely discharged, it will not begin charging immediately. Wait a few minutes.</p> <p>If the battery still does not charge, make sure the outlet of the AC adaptor is supplying power.</p> <p>Test it by plugging in an appliance.</p> <hr/> <p>Check whether the battery is hot or cold to the touch. If the battery is too hot or too cold, it will not charge properly. Let it reach room temperature.</p> <hr/> <p>Unplug the AC adaptor and remove the battery to make sure the terminals are clean. If necessary wipe them with a soft dry cloth dipped in alcohol.</p> <p>Connect the AC adaptor and replace the battery. Make sure it is securely seated.</p> <p>Check the Battery indicator. If it does not glow, let the computer charge the battery for at least 20 minutes. If the Battery indicator glows after 20 minutes, let the battery continue to charge at least another 20 minutes before turning on the computer.</p> <p>If the indicator still does not glow, the battery may be at the end of its operating life. Replace it.</p> <p>If you do not think the battery is at the end of its operating life, see your dealer.</p>
<p>Battery doesn't power the computer as long as expected</p>	<p>If you frequently recharge a partially charged battery, the battery might not charge to its full potential. Fully discharge the battery, then try to charge it again.</p> <hr/> <p>Check the power consumption settings in TOSHIBA Power Saver utility. Consider using a power saving mode.</p>

Real Time Clock

Problem	Procedure
<p>The following message is Displayed on the LCD screen:</p> <p>RTC battery is low or CMOS checksum is inconsistent. Press [F1] key to set Date/Time.</p>	<p>The battery for RTC is wearing. Set the date and time in BIOS setup with the following steps:</p> <ol style="list-style-type: none"> 1. Press F1 key. BIOS setup will boot up. 2. Set the date in System Date. 3. Set the time in System Time. 4. Press End key. Confirmation message will appear. 5. Press Y key. BIOS setup will terminate and the computer will be rebooted.

Password

Problem	Procedure
Cannot enter password	Refer to the TOSHIBA Password Utility section in Chapter 6, Power and Power-Up Modes .

Keyboard

Keyboard problems can be caused by your setup configuration. For more information refer to Chapter 5, [The Keyboard](#) .

Problem	Procedure
Some letter keys produce numbers	Check that the numeric keypad overlay is not selected. Press Fn + F10 and try typing again.
Output to screen is garbled	<p>Make sure the software you are using is not remapping the keyboard. Remapping involves reassigning the meaning of each key. See your software's documentation.</p> <p>If you are still unable to use the keyboard, consult your dealer.</p>

Internal LCD display panel

Apparent LCD problems may be related to the computer's setup. Refer to Chapter 7, *HW Setup*, for more information.

Problem	Procedure
No display	Press hotkeys Fn + F5 to change the display priority, to make sure it is not set for an external monitor.
Markings appear on the LCD screen.	They might have come from contact with the keyboard, Touch Pad. Try wiping the LCD screen gently with a clean dry cloth. If markings remain, use LCD screen cleaner. Be sure to let the LCD screen dry before closing it.
Problems above remain unresolved or other problems occur	Refer to your software's documentation to determine if the software is causing the difficulty. Run the diagnostic test. Contact your dealer if the problems continue.

Hard disk drive

Problem	Procedure
Computer does not boot from hard disk drive	Check if a floppy disk is in the floppy disk drive or a CD-ROM is in the optical media drive. Remove any floppy disk and/or CD-ROM and check Boot priority. Refer to the <i>Boot Priority</i> section in Chapter 7, HW Setup . There may be a problem with your operating system files. Refer to your OS documentation.
Slow performance	Your files may be fragmented. Run Disk Defragmenter to check the condition of your files and disk. Refer to your OS documentation or online HELP for information on running the Disk Defragmenter. As a last resort, reformat the hard disk. Then, reload the operating system and other files. If problems persist, contact your dealer.

DVD-ROM&CD-R/RW drive

For more information, refer to Chapter 4, *Operating Basics*.

Problem	Procedure
<p>You cannot access a CD/DVD in the drive</p>	<p>Make sure the drive's disc tray is securely closed. Press gently until it clicks into place.</p> <hr/> <p>Check whether the drive power is on. If the power is off, click on the optical media drive icon in the task tray and turn on the power.</p> <hr/> <p>Open the disc tray and make sure the CD/DVD is properly seated. It should lie flat with the label facing up.</p> <hr/> <p>A foreign object in the disc tray could block laser light from reading the CD/DVD. Make sure there is no obstruction. Remove any foreign object.</p> <hr/> <p>Check whether the CD/DVD is dirty. If it is, wipe it with a clean cloth dipped in water or a neutral cleaner. Refer to the <i>Media care</i> section in Chapter 4 for details on cleaning.</p>
<p>Some CD/DVDs run correctly, but others do not</p>	<p>The software or hardware configuration may be causing a problem. Make sure the hardware configuration matches your software's needs. Check the CD/DVD's documentation.</p> <hr/> <p>Check the type of CD/DVD you are using. The drive supports:</p> <p>DVD-ROM: DVD-ROM, DVD-Video</p> <p>CD-ROM: CD-DA, CD-Text, Photo CD™ (single/multi-session), CD-ROM Mode 1, Mode 2, CD-ROM XA Mode 2 (Form1, Form2), Enhanced CD (CD-EXTRA), Addressing Method 2</p> <p>Recordable CD: CD-R, CD-RW</p> <hr/> <p>Check the region code on the DVD. It must match that on the DVD-ROM&CD-R/RW drive. Region codes are listed in the <i>Optical media drives</i> section in Chapter 2, The Grand Tour.</p>

Problem	Procedure
Cannot write correctly	<p>If you have trouble writing, make sure you are observing the following precautions:</p> <ul style="list-style-type: none"> ■ Use only media recommended by TOSHIBA. ■ Do not use the mouse or keyboard during writing. ■ Use only the software supplied with the computer for recording. ■ Do not run or start other software during writing. ■ Do not jar the computer during writing. ■ Do not connect/disconnect external devices or install/remove internal cards during writing. <p>If problems persist, contact your dealer.</p>

DVD Super Multi drive

For more information, refer to Chapter 4, *Operating Basics*.

Problem	Procedure
You cannot access a CD/DVD in the drive	<p>Make sure the drive's disc tray is securely closed. Press gently until it clicks into place.</p> <hr/> <p>Check whether the drive power is on. If the power is off, click on the optical media drive icon in the task tray and turn on the power.</p> <hr/> <p>Open the disc tray and make sure the CD/DVD is properly seated. It should lie flat with the label facing up.</p> <hr/> <p>A foreign object in the disc tray could block laser light from reading the CD/DVD. Make sure there is no obstruction. Remove any foreign object.</p> <hr/> <p>Check whether the CD/DVD is dirty. If it is, wipe it with a clean cloth dipped in water or a neutral cleaner. Refer to the <i>Media care</i> section in Chapter 4 for details on cleaning.</p> <hr/> <p>Some CD/DVDs run correctly, but others do not</p> <p>The software or hardware configuration may be causing a problem. Make sure the hardware configuration matches your software's needs. Check the CD/DVD's documentation.</p>

Check the type of CD/DVD you are using. The drive supports:

DVD-ROM: DVD-ROM, DVD-Video

CD-ROM: CD-DA, CD-Text, Photo CD™ (single/multi-session), CD-ROM Mode 1, Mode 2, CD-ROM XA Mode 2 (Form1, Form2), Enhanced CD (CD-EXTRA), Addressing Method 2

Check the region code on the DVD. It must match that on the DVD Super Multi drive. Region codes are listed in the [Optical media drives](#) section in Chapter 2, The Grand Tour.

USB floppy disk drive

For more information, refer to Chapter 4, [Operating Basics](#).

Problem	Procedure
Drive does not operate	There may be a faulty cable connection. Check the connection to the computer and to the drive.
Some programs run correctly but others do not	The software or hardware configuration may be causing a problem. Make sure the hardware configuration matches your software needs.
You cannot access the external 3 1/2" floppy disk drive	Try another floppy disk. If you can access the floppy disk, the original floppy disk (not the drive) is probably causing the problem. If problems persist, contact your dealer.

SD card

Refer also to Chapter 8, [Optional Devices](#) .

Problem	Procedure
SD card error occurs	Reseat the SD card to make sure it is firmly connected. Check the card's documentation.
You cannot write to an SD memory card	Make sure the card is not write protected.
You cannot read a file	Make sure the target file is on the SD memory card inserted in the slot. If problems persist, contact your dealer.

PC card

Refer also to Chapter 8, [Optional Devices](#) .

Problem	Procedure
PC card error occurs	<p>Reseat the PC card to make sure it is firmly connected.</p> <hr/> <p>Make sure the connection between the external device and the card is firm.</p> <hr/> <p>Check the card's documentation.</p> <p>If problems persist, contact your dealer.</p>

CF card

Refer also to Chapter 8, [Optional Devices](#) .

Problem	Procedure
CF card error occurs	<p>Reseat the CF card to make sure it is firmly connected.</p> <p>Check the card's documentation.</p>
You cannot read a file	<p>Make sure the target file is on the CF card inserted in the slot.</p> <p>If problems persist, contact your dealer.</p>

Infrared port

Refer also to the documentation for your IrDA compatible device and related software.

Problem	Procedure
Infrared devices do not work as expected	<p>Make sure there is no obstruction blocking communication between the computer and the target device.</p> <p>If problems persist, contact your dealer.</p>

Pointing Device

If you are using a USB mouse, also refer to the [USB](#) section in this chapter and to your mouse documentation.

Touch Pad

Problem	Procedure
On-screen pointer does not respond to Pad operation	The system might be busy. If the pointer is shaped as an hourglass, wait for it to standby its normal shape and try again to move it.
Double-tapping does not work	<p>Try changing the double-click speed setting in the mouse control utility.</p> <ol style="list-style-type: none"> 1. Click start, click Control Panel, click Printers and Other Hardware and select Mouse icon. 2. Click the Buttons tab. 3. Set the double-click speed as instructed and click OK.
The mouse pointer moves too fast or too slow	<p>Try changing the speed setting in the mouse control utility.</p> <ol style="list-style-type: none"> 1. Click start, click Control Panel, click Printers and Other Hardware and select Mouse icon. 2. Click the Pointer Options tab. 3. Set the speed as instructed and click OK. <p>If problems persist, contact your dealer.</p>
When the reaction of Touch pad is sensitive or blunt.	<p>Adjust the touch Sensitivity.</p> <ol style="list-style-type: none"> 1. Click start and open the Control Panel. 2. Click the Printers and Other Hardware icon. 3. Click the Mouse icon. 4. Click the Device Setting tab. 5. Click the Setting button. 6. The Properties for Synaptics Touch pad on PS/2 port screen appears. Double-click Sensitivity in the Select an item section on the left side of the screen. 7. PalmCheck and Touch Sensitivity are displayed. Click Touch Sensitivity. 8. Move the slide bar for Touch Sensitivity to make an adjustment. Click the OK button. 9. Click the OK button on the Device Setting tab.

USB mouse (optional)

Problem	Procedure
On-screen pointer does not respond to mouse operation	<p>The system might be busy. If the pointer is shaped as an hourglass, wait for it to resume its normal shape and try again to move it.</p> <hr/> <p>Make sure the mouse is properly connected to the USB port.</p>
Double-clicking does not work	<p>Try changing the double-click speed setting in the mouse control utility.</p> <ol style="list-style-type: none"> 1. Click start, click Control Panel, click Printers and Other Hardware and select Mouse icon. 2. Click the Buttons tab. 3. Set the double-click speed as instructed and click OK.
The mouse pointer moves too fast or too slow	<p>Try changing the speed setting in the mouse control utility.</p> <ol style="list-style-type: none"> 1. Click start, click Control Panel, click Printers and Other Hardware and select Mouse icon. 2. Click the Pointer Options tab. 3. Set the speed as instructed and click OK.
The mouse pointer moves erratically	<p>The mouse might be dirty. Refer to your mouse documentations for instructions on cleaning. If problems persist, contact your dealer.</p>

USB

Refer also to your USB device's documentation.

Problem	Procedure
USB device does not work	<p>Check for a firm cable connection between the USB ports on the computer and the USB device.</p> <hr/> <p>Make sure the USB device drivers are properly installed. Refer to your Windows XP documentation for information on checking the drivers.</p> <hr/> <p>If you are using an operating system that does not support USB, you can still use a USB mouse and/or USB keyboard. If these devices do not work, make sure the USB KB/Mouse Legacy Emulation item in HW Setup is set to Enabled. If problems persist, contact your dealer.</p>

Memory expansion

Refer also to Chapter 8, *Optional Devices*, for information on installing memory modules.

Problem	Procedure
Beep sounds. (Two beeps, a dash and a dot, for a defective memory module in slot.)	<p>Make sure the memory module installed in the memory slot is compatible with the computer.</p> <p>If an incompatible module has been installed, follow the steps below.</p> <ol style="list-style-type: none"> 1. Turn off the computer. 2. Disconnect the AC adaptor and all peripheral devices. 3. Remove the battery pack. 4. Remove the memory module. 5. Install the battery and/or connect the AC adaptor. 6. Turn on the power. <p>If problems persist, contact your dealer.</p>

Sound System

Refer also to documentation for your audio devices.

Problem	Procedure
No sound is heard	<p>Adjust the volume control dial.</p> <hr/> <p>Check the software volume settings.</p> <hr/> <p>Make sure the headphone connection is secure. If problems persist, contact your dealer.</p> <hr/> <p>Check Windows Device Manager. Make sure the sound function is enabled and that settings for I/O address, Interrupt level and DMA are correct for your software and do not conflict with other hardware devices that you may have connected to the computer.</p>

External monitor

Refer also to Chapter 8, *Optional Devices*, and to your monitor's documentation.

Problem	Procedure
Monitor does not turn on	<p>Make sure that the external monitor's power switch is on. Confirm that the external monitor's power cable is plugged into a working power outlet.</p>
No display	<p>Try adjusting the contrast and brightness controls on the external monitor.</p> <hr/> <p>Press hot keys Fn + F5 to change the display priority and make sure it is not set for the internal LCD.</p>
Display error occurs	<p>Check that the cable connecting the external monitor to the computer is attached firmly. If problems persist, contact your dealer.</p>

i.LINK (IEEE1394)

Problem	Procedure
i.LINK device does not function	<p>Make sure the cable is securely connected to the computer and to the device.</p> <p>Make sure the device's power is turned on.</p> <p>Reinstall the drivers. Open the Windows Control Panel and double-click the Add Hardware icon. Follow the on-screen directions.</p> <p>Restart Windows.</p> <p>If problems persist, contact your dealer.</p>

Modem

Problem	Procedure
Communication software can't initialize modem	Make sure the computer's internal modem settings are correct. Refer to <i>Phone and Modem Properties</i> in the Control Panel.
You can hear a dial tone but can't make a call	<p>If the call is going through a PBX machine, make sure the communication application's tone dial detection feature is disabled.</p> <p>You can also use the ATX command.</p>
You place a call, but a connection can't be made	Make sure the settings are correct in your communications application.
After making a call you can't hear a ring	<p>Make sure the tone or pulse selection in your communications application is set correctly.</p> <p>You can also use the ATD command.</p>
Communication is cut off unexpectedly	The computer will automatically cut off communication when connection with the carrier is not successful for a set time interval. Try lengthening this time interval.
A CONNECT display is quickly replaced by NO CARRIER	<p>Check the error control setting in your communications application.</p> <p>You can also use the ATIN command.</p>
Character display becomes garbled during a communication	<p>In data transmission, make sure the parity bit and stop bit settings correspond with those of the remote computer.</p> <p>Check the flow control and communication protocol.</p>

Problem	Procedure
You cannot receive an incoming call	Check the rings before auto answer setting in your communications application. You can also use the ATSO command. If problems persist, contact your dealer.

LAN

Problem	Procedure
Cannot access LAN	Check for a firm cable connection between the LAN jack and the LAN HUB.
Wake-up on LAN does not work	Make sure the AC adaptor is connected. The Wake-up on LAN function consumes power even when the system is off. If problems persist, consult your LAN administrator.

Wireless LAN

If the following procedures do not restore LAN access, consult your LAN administrator. For more information on wireless communication, refer to Chapter 4, *Operating Basics*.

Problem	Procedure
Cannot access Wireless LAN	Make sure the computer's wireless communication switch is set to on. If problems persist, contact your LAN administrator.

Bluetooth

For more information on wireless communication, refer to Chapter 4, *Operating Basics*.

Problem	Procedure
Cannot access Bluetooth device	<p>Make sure the computer's wireless communication switch is set to on.</p> <hr/> <p>Make sure the Bluetooth Manager is running and the power to the Bluetooth device is turned on.</p> <hr/> <p>Make sure no optional Bluetooth PC card and Bluetooth SD card are installed in the computer. The built-in Bluetooth function and an optional Bluetooth PC card cannot operate simultaneously. If problems persist, contact your dealer.</p>

Printer

Refer also to the *Parallel printer* sections in Chapter 8, *Optional Devices* , and to the troubleshooting and other relevant sections in your printer and software documentation.

Problem	Procedure
Printer does not turn on.	Check that the printer is connected to an electric outlet. Make sure the outlet is supplying power by plugging in an appliance.
Computer/printer do not communicate	<p>Make sure the printer is turned on and is online (ready to use).</p> <p>Inspect the cable connecting the printer to the computer for damage. Make sure it is securely connected.</p> <p>A parallel printer connects to the parallel port. Make sure the port is configured correctly. Refer to Chapter 7, <i>HW Setup</i> .</p> <p>Make sure your software is configured to recognize the printer. Check your printer and software documentation.</p>
Printer error	<p>Check your printer documentation.</p> <p>If problems persist, contact your dealer.</p>

TOSHIBA support

If you require any additional help using your computer or if you are having problems operating the computer, you may need to contact TOSHIBA for additional technical assistance.

Before you call

Some problems you experience may be related to software or the operating system, it is important to investigate other sources of assistance first. Before contacting TOSHIBA, try the following:

- Review troubleshooting sections in the documentation for software and peripheral devices.
- If a problem occurs when you are running software applications, consult the software documentation for troubleshooting suggestions. Call the software company's technical support for assistance.
- Consult the dealer you purchased your computer and/or software from. They are your best sources for current information and support.

Where to write

If you are still unable to solve the problem and suspect that it is hardware related, write to TOSHIBA at the location listed in the accompanying warranty booklet or visit www.toshiba-europe.com on the Internet.

Appendix A

Specifications

This appendix summarizes the computer's technical specifications.

Physical Dimensions

Size	286.0 (w) × 233.0 (d) × 28.9/32.9(h) millimeters (not including parts that extend beyond the main body)
-------------	---------------------------------------------------------------------------------------------------------

Environmental Requirements

Conditions	Ambient temperature	Relative humidity
Operating	5°C (41°F) to 35°C (95°F)	20% to 80%
Non-operating	-20°C (-4°F) to 65°C (149°F)	10% to 95%
Thermal Gradient	20°C per hour maximum	
Wet-bulb temperature	26°C maximum	
Conditions	Altitude (from sea level)	
Operating	-60 to 3,000 meters	
Non-operating	-60 to 10,000 meters maximum	

Power Requirements

AC adaptor	100-240 volts AC 50 or 60 hertz (cycles per second)
Computer	15 VDC 4.0 amperes

Built-in Modem

Network control unit (NCU)	
Type of NCU	AA
Type of line	Telephone line (analog only)
Type of dialing	Pulse Tone
Control command	AT commands EIA-578 commands
Monitor function	Computer's speaker
Communication specifications	
Communication system	Data: Full duplex Fax: Half duplex
Communication protocol	Data ITU-T-Rec V.21/V.22/V.22bis/V.32 (Former CCITT) V.32bis/V.34/V.90 Bell 103/212A Fax ITU-T-Rec V.17/V.29/V.27ter (Former CCITT) V.21 ch2
Communication speed	Data transmission and reception 300/1200/2400/4800/7200/9600/12000/14400/ 16800/19200/21600/24000/26400/28800/31200/ 33600 bps Data reception only with V.90 28000/29333/30666/32000/33333/34666/36000/ 37333/38666/40000/41333/42666/44000/45333/ 46666/48000/49333/50666/52000/53333/54666/ 56000 bps Fax 2400/4800/7200/9600/12000/14400 bps
Transmitting level	-10 dBm
Receiving level	-10 to -40 dBm
Input/output impedance	600 ohms \pm 30%
Error correcting	MNP class 4 and ITU-T V.42
Data compression	MNP class 5 and ITU-T V.42bis
Power supply	+3.3V (supplied by computer)

Appendix B

Display Controller and Modes

Display controller

The display controller interprets software commands into hardware commands that turn particular pels on or off.

The controller is an advanced Video Graphics Array (VGA) that provides Extended Graphics Array (XGA) support for the internal LCD and external monitors.

A high-resolution external monitor connected to the computer can display up to 2048 horizontal and 1536 vertical pixels at up to 64K mode.

The display controller also controls the video mode, which uses industry standard rules to govern the screen resolution and the maximum number of colors that can be displayed on screen.

Software written for a given video mode will run on any computer that supports the mode.

The computer's display controller supports all VGA and Super VGA modes, the most widely used industry standards.

Video modes

The computer supports video modes defined in the tables below. If your application offers a selection of mode numbers that do not match the numbers on the table, select a mode based on mode type, resolution, character matrix, number of colors and refresh rates. Also, if your software supports both graphics and text modes, the screen display may appear to operate faster using a text mode.

Table1 Video modes (VGA)

Video mode	Type	Resolution	Character matrix (pels)	LCD colors	CRT colors	Scanning frequency Vertical (Hz)
0, 1	VGA Text	40 × 25 Characters	8 × 8	16 of 256K	16 of 256K	70
2, 3	VGA Text	80 × 25 Characters	8 × 8	16 of 256K	16 of 256K	70
0*, 1*	VGA Text	40 × 25 Characters	8 × 14	16 of 256K	16 of 256K	70
2*, 3*	VGA Text	80 × 25 Characters	8 × 14	16 of 256K	16 of 256K	70
0+, 1+	VGA Text	40 × 25 Characters	9 × 16	16 of 256K	16 of 256K	70
2+, 3+	VGA Text	80 × 25 Characters	9 × 16	16 of 256K	16 of 256K	70
4, 5	VGA Grph	320 × 200 Pels	8 × 8	4 of 256K	4 of 256K	70
6	VGA Grph	640 × 200 Pels	8 × 8	2 of 256K	2 of 256K	70
7	VGA Text	80 × 25 Characters	9 × 14	Mono	Mono	70
7+	VGA Text	80 × 25 Characters	9 × 16	Mono	Mono	70

Table1 Video modes (VGA) continued

Video mode	Type	Resolution	Character matrix (pels)	LCD colors	CRT colors	Scanning frequency Vertical (Hz)
D	VGA Grph	320 × 200 Pels	8 × 8	16 of 256K	16 of 256K	70
E	VGA Grph	640 × 200 Pels	8 × 8	16 of 256K	16 of 256K	70
F	VGA Grph	640 × 350 Pels	8 × 14	Mono	Mono	70
10	VGA Grph	640 × 350 Pels	8 × 14	16 of 256K	16 of 256K	70
11	VGA Grph	640 × 480 Pels	8 × 16	2 of 256K	2 of 256K	60
12	VGA Grph	640 × 480 Pels	8 × 16	16 of 256K	16 of 256K	60
13	VGA Grph	320 × 200 Pels	8 × 8	256 of 256K	256 of 256K	70

Table 2 Video modes

Resolution	LCD colors	CRT colors	Vertical frequency (Hz)
640 × 480	256/256K	256/256K	60 75 85 100
800 × 600	256/256K	256/256K	60 75 85 100
1024 × 768	256/256K	256/256K	60 75 85 100
1280 × 1024	256/256K (Virtual)	256/256K	60 75 85 100
1400 × 1050	256/256K (Virtual)	256/256K	60 75 85
1600 × 1200	256/256K (Virtual)	256/256K	60 75 85 100
1920 × 1440	256/256K (Virtual)	256/256K	60 75 85
2048 × 1536	256/256K (Virtual)	256/256K	60 75



Some video modes are not supported in the following modes: the Internal/External Simultaneous Display mode and the Internal/External Multi Monitor mode.

Table 2 Video modes continued

Resolution	LCD colors	CRT colors	Vertical frequency (Hz)
640 × 480	64K/64K	64K/64K	60 75 85 100
800 × 600	64K/64K	64K/64K	60 75 85 100
1024 × 768	64K/64K	64K/64K	60 75 85 100
1280 × 1024	64K/64K (Virtual)	64K/64K	60 75 85 100
1400 × 1050	64K/64K (Virtual)	64K/64K	60 75 85
1600 × 1200	64K/64K (Virtual)	64K/64K	60 75 85 100
1920 × 1440	64K/64K (Virtual)	64K/64K	60 75 85
2048 × 1536	64K/64K (Virtual)	64K/64K	60 75



Some video modes are not supported in the following modes: the Internal/External Simultaneous Display mode and the Internal/External Multi Monitor mode.

Table 2 Video modes continued

Resolution	LCD colors	CRT colors	Vertical frequency (Hz)
640 × 480	16M/16M	16M/16M	60 75 85 100
800 × 600	16M/16M	16M/16M	60 75 85 100
1024 × 768	16M/16M	16M/16M	60 75 85 100
1280 × 1024	16M/16M (Virtual)	16M/16M	60 75 85 100
1400 × 1050	16M/16M (Virtual)	16M/16M	60 75 85
1600 × 1200	16M/16M (Virtual)	16M/16M	60 75 85



Some video modes are not supported in the following modes: the Internal/External Simultaneous Display mode and the Internal/External Multi Monitor mode.

Display settings

1. You cannot move from the [Settings] tab of [Display Properties] to the multi-monitor when you are using the display of the computer and an external CRT display or a TV at the same time.

*The [Settings] tab is displayed in the following steps;

- 1) Open [Control Panel], click [Appearance and Themes].
- 2) Click [display].
- 3) Select [Settings] tab.

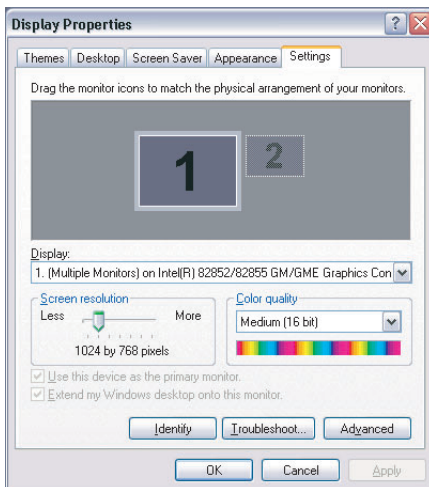

Display Properties (1)

- The way to move to multi-monitor
 - 1) Press [Ctrl] + [Alt] + [F12] keys to make. [Intel(R) 82852/82855 GM/GME Graphics Controller Prope...] displayed.
 - 2) Click  in the left of [Devices] tab, then select [Extended Desktop].

- 3) Select either Monitor (CRT display) or Television, then select Apply button, because the Primary Device is fixed into Notebook (the display of the computer).

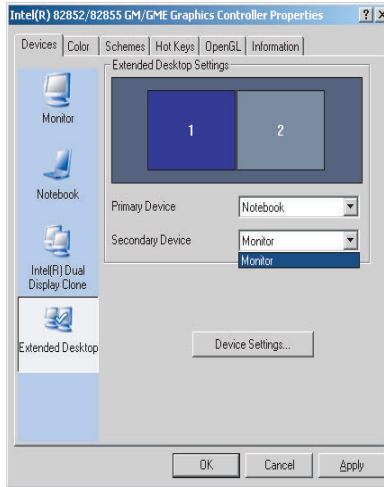

Intel(R) 82852/82855 GM/GME Graphics Controller Prope...(1)

2. Some reproduced DVD picture may not be displayed when the display of the computer and a CRT display are used at the same. Reduce the resolution, use the display of the computer only, use the CRT display only or set display device in the multi-monitor, then play DVD.

Please refer to the [External monitor](#) section in Chapter 8, *Optional Devices* or the application guide for the setting of each display device.

3. When playback DVD title with Multiple Monitors mode, there are some case that DVD Overlay is not shown. In this case, please try to playback WinDVD with decreasing resolution, refresh rate or color depth after exit WinDVD player.
4. There are some case that you can select non-support mode with LCD/CRT Dual Clone mode or MultiMonitor mode. In this case, please try to decrease CRT resolution, refresh rate or color depth.

Appendix C

Wireless LAN

Card Specifications

Form Factor	Mini PCI Type III
Compatibility	<ul style="list-style-type: none">■ IEEE 802.11 Standard for Wireless LANS■ Wi-Fi (Wireless Fidelity) certified by the Wi-Fi Alliance. The 'Wi-Fi CERTIFIED' logo is a certification mark of the Wi-Fi Alliance.
Network Operating System	<ul style="list-style-type: none">■ Microsoft Windows® Networking
Media Access Protocol	<ul style="list-style-type: none">■ CSMA/CA (Collision Avoidance) with Acknowledgment (ACK)
Data Rate	<ul style="list-style-type: none">■ Theoretical maximum speed: 54Mbps (IEEE802.11a/IEEE802.11g: 11b/g, 11a/b/g combo type)■ Theoretical maximum speed: 11Mbps (IEEE802.11b)■ Theoretical maximum speed: 108Mbps (Turbo Mode: Atheros module type)

Radio Characteristics

Radio Characteristics of Wireless LAN Cards may vary according to:

- Country/region where the product was purchased
- Type of product

Wireless communication is often subject to local radio regulations. Although Wireless LAN wireless networking products have been designed for operation in the license-free 2.4GHz and 5GHz band, local radio regulations may impose a number of limitations to the use of wireless communication equipment.



Refer to the sheet "Information to the User" for regulatory information that may apply in your country/region.

R-F Frequency

- Band 5GHz (5150-5850 MHz) (Revision A, Turbo Mode)
- Band 2.4GHz (2400-2483.5 MHz) (Revision B, G, Turbo Mode)

Modulation Technique

- DSSS-CCK, DSSS-DQPSK, DSSS-DBPSK (Revision B)
 - OFDM-BPSK, OFDM-QPSK, OFDM-16QAM, OFDM-64QAM (Revision A, G, Turbo Mode)
-

The range of the wireless signal is related to the transmit rate of the wireless communication. Communications at lower transmit range may travel larger distances.

- The range of your wireless devices can be affected when the antennas are placed near metal surfaces and solid high-density materials.
- Range is also impacted due to "obstacles" in the signal path of the radio that may either absorb or reflect the radio signal.

Supported Frequency Sub-bands

Subject to the radio regulations that apply in the countries/regions, your Wireless LAN card may support a different set of 5 GHz/2.4 GHz channels. Consult your Authorized Wireless LAN or TOSHIBA Sales office for information about the radio regulations that apply in the countries/regions.

Wireless IEEE 802.11 Channels Sets (Revision B and G)

Frequency Range Channel ID	2400-2483.5 MHz
1	2412
2	2417
3	2422
4	2427
5	2432
6	2437
7	2442
8	2447
9	2452
10	2457 *1
11	2462
12	2467 *2
13	2472 *2

*1 Factory-set default channels

*2 Consult your Authorized Wireless LAN or TOSHIBA Sales office for information about the countries/regions in which these channels can be used.

When installing Wireless LAN cards, the channel configuration is managed as follows:

- For wireless clients that operate in a Wireless LAN Infrastructure, the Wireless LAN card will automatically start operation at the channel identified by the Wireless LAN Access Point. When roaming between different access points the station can dynamically switch to another channel if required.
- For Wireless LAN cards installed in wireless clients that operating in a peer-to-peer mode, the card will use the default channel 10.
- In a Wireless LAN Access Point, the Wireless LAN card will use the factory-set default channel (printed in bold), unless the LAN Administrator selected a different channel when configuring the Wireless LAN Access Point device.

Wireless IEEE 802.11 Channels Sets (Revision A)

Frequency Range Channel ID	5150-5850 MHz
36	5180
40	5200
44	5220
48	5240
52	5260
56	5280
60	5300
64	5320
100	5500
104	5520
108	5540
112	5560
116	5580
120	5600
124	5620
128	5640
132	5660
136	5680
140	5700
149	5745
153	5765
157	5785
161	5805

Wireless Channels Sets (Turbo Mode)

Frequency Range Channel ID	2400-2483.5 MHz	Note
6	2437	US only *3

*3 These channels are available to Atheros module type only.

Wireless Channels Sets (Turbo Mode)

Frequency Range Channel ID	5150-5850 MHz	Note
42	5210	US only *4
50	5250	US only *4
58	5290	US only *4
152	5760	US only *4
160	5800	US only *4

*4 These channels are available to Atheros A/B/G combo type only.

Appendix D

Bluetooth wireless technology Interoperability

Bluetooth™ Cards from TOSHIBA are designed to be interoperable with any product with Bluetooth wireless technology that is based on Frequency Hopping Spread Spectrum (FHSS) radio technology, and is compliant to:

- Bluetooth Specification Ver.1.2, as defined and approved by The Bluetooth Special Interest Group.
- Logo certification with Bluetooth wireless technology as defined by The Bluetooth Special interest Group.



- *Bluetooth wireless technology is a new innovative technology, and TOSHIBA has not confirmed compatibility of its Bluetooth™ products with all computers and/or equipment using Bluetooth wireless technology other than TOSHIBA portable computers. Always use Bluetooth™ Cards from TOSHIBA in order to enable wireless networks over two or more (up to a total of seven) TOSHIBA portable computers using these cards. Please contact TOSHIBA PC product support on Web site <http://www.toshiba-europe.com/computers/tnt/bluetooth.htm> in Europe or <http://www.pc.support.global.toshiba.com> in the United States for more information.*
- *When you use Bluetooth™ Cards from TOSHIBA close to 2.4 GHz Wireless LAN devices, Bluetooth transmissions might slow down or cause errors. If you detect certain interference while you use Bluetooth™ Cards from TOSHIBA, always change the frequency, move your computer to the area outside of the interference range of 2.4 GHz Wireless LAN devices (40 meters/43.74 yards or more) or stop transmitting from your computer. Please contact TOSHIBA PC product support on Web site <http://www.toshiba-europe.com/computers/tnt/bluetooth.htm> in Europe or <http://www.pc.support.global.toshiba.com> in the United States for more information.*
- *Bluetooth™ and Wireless LAN devices operate within the same radio frequency range and may interfere with one another. If you use Bluetooth™ and Wireless LAN devices simultaneously, you may occasionally experience a less than optimal network performance or even lose your network connection. If you should experience any such problem, immediately turn off either one of your Bluetooth™ or Wireless LAN. Please contact TOSHIBA PC product support on web site <http://www.toshiba-europe.com/computers/tnt/bluetooth.htm> in Europe or <http://www.pc.support.global.toshiba.com> in the United States for more information.*

Bluetooth wireless technology and your Health

The products with Bluetooth wireless technology, like other radio devices, emit radio frequency electromagnetic energy. The level of energy emitted by devices with Bluetooth wireless technology however is far much less than the electromagnetic energy emitted by wireless devices like for example mobile phones.

Because products with Bluetooth wireless technology operate within the guidelines found in radio frequency safety standards and recommendations, TOSHIBA believes Bluetooth wireless technology is safe for use by consumers. These standards and recommendations reflect the consensus of the scientific community and result from deliberations of panels and committees of scientists who continually review and interpret the extensive research literature.

In some situations or environments, the use of Bluetooth wireless technology may be restricted by the proprietor of the building or responsible representatives of the organization. These situations may for example include:

- Using the equipment with Bluetooth wireless technology on board of airplanes, or
- In any other environment where the risk of interference to other devices or services is perceived or identified as harmful.

If you are uncertain of the policy that applies on the use of wireless devices in a specific organization or environment (e.g. airports), you are encouraged to ask for authorization to use the device with Bluetooth wireless technology prior to turning on the equipment.

Regulatory statements

General

This product complies with any mandatory product specification in any country/region where the product is sold. In addition, the product complies with the following.

European Union (EU) and EFTA

This equipment complies with the R&TTE directive 1999/5/EC and has been provided with the CE mark accordingly.

Canada - Industry Canada (IC)

This device complies with RSS 210 of Industry Canada.

Operation is subject to the following two conditions: (1) this device may not cause interference, and (2) this device must accept any interference, including interference that may cause undesired operation of this device.

L' utilisation de ce dispositif est autorisée seulement aux conditions suivantes: (1) il ne doit pas produire de brouillage et (2) l' utilisateur du dispositif doit être prêt à accepter tout brouillage radioélectrique reçu, même si ce brouillage est susceptible de compromettre le fonctionnement du dispositif.

The term "IC" before the equipment certification number only signifies that the Industry Canada technical specifications were met.

IC: 248H-DPA3232B

Caution: FCC Interference Statement

This device complies with part 15 of the FCC rules. Operation is subject to the following two conditions:

- This device may not cause harmful interference, and
- This device must accept any interference received, including interference that may cause undesired operation.

Note that any changes or modifications to this equipment not expressly approved by the manufacturer may void the authorization to operate this equipment.

Caution: Exposure to Radio Frequency Radiation

The radiated output power of the Bluetooth™ Card from TOSHIBA is far below the FCC radio frequency exposure limits.

Nevertheless, the Bluetooth™ Card from TOSHIBA shall be used in such a manner that the potential for human contact during normal operation is minimized. In order to comply with FCC radio frequency radiation exposure guidelines for an uncontrolled environment, the Bluetooth™ Card from TOSHIBA has to be operated while maintaining a minimum body to antenna which are located on top of LCD distance of 20 cm. Refer to the Regulatory Statements as identified in the documentation that comes with those products for additional information. The Bluetooth™ Card from TOSHIBA is far below the FCC radio frequency exposure limits.

Nevertheless, it is advised to use the Bluetooth™ Card from TOSHIBA in such a manner that human contact during normal operation is minimized.

(The model with embedded Wireless LAN module: PA3171U-1MPC)

Relevant transmitters include FCC IDs: CJ6PA3171WL,
CJ6UPA3232BT

(The model with embedded Wireless LAN module: PA3272U-1MPC)

Relevant transmitters include FCC IDs: CJ6UPA3272WLP,
CJ6UPA3232BT

(The model with embedded Wireless LAN module: PA3231U-1MPC)

Relevant transmitters include FCC IDs: CJ6UPA3231WL,
CJ6UPA3232BT

(The model with embedded Wireless LAN module e: PA3233U-1MPC)

Relevant transmitters include FCC IDs: CJ6UPA3233WL,
CJ6UPA3232BT

- (The model with embedded Wireless LAN module: PA3234U-1MPC)
Relevant transmitters include FCC IDs: CJ6UPA3234WL,
CJ6UPA3232BT
- (The model with embedded Wireless LAN module: PA3297U-1MPC)
Relevant transmitters include FCC IDs: CJ6UPA3297WL,
CJ6UPA3232BT
- (The model with embedded Wireless LAN module: PA3299U-1MPC)
Relevant transmitters include FCC IDs: CJ6UPA3299WLP,
CJ6UPA3232BT
- (The model with embedded Wireless LAN module: PA3362U-1MPC)
Relevant transmitters include FCC IDs: CJ6UPA3362WL,
CJ6UPA3232BT
- (The model with embedded Wireless LAN module: PA3373U-1MPC)
Relevant transmitters include FCC IDs: CJ6UPA3373WL,
CJ6UPA3232BT
- (The model with embedded Wireless LAN module: PA3374U-1MPC)
Relevant transmitters include FCC IDs: CJ6UPA3374WL,
CJ6UPA3232BT
- (The model with embedded Wireless LAN module: PA3375-1MPC)
Relevant transmitters include FCC IDs: CJ6UPA3375WL,
CJ6UPA3232BT



Changes or modifications made to this equipment not expressly approved by TOSHIBA or parties authorized by TOSHIBA could void the user's authority to operate the equipment.

Taiwan

Article 14 Unless approved, for any model accredited low power radio frequency electric machinery, any company, trader or user shall not change the frequency, increase the power or change the features and functions of the original design.

Article 17 Any use of low power radio frequency electric machinery shall not affect the aviation safety and interfere with legal communications. In event that any interference is found, the use of such electric machinery shall be stopped immediately, and reusing of such products can be resumed until no interference occurs after improvement.

The legal communications mentioned in the above item refer to radio communications operated in accordance with telecommunication laws and regulations.

Low power radio frequency electric machinery shall resist against interference from legal communications or from industrial, scientific and medical radio emission electric machinery.

Using Bluetooth™ Card from TOSHIBA equipment in Japan

In Japan, the frequency bandwidth of 2,400~2,483.5 MHz for second generation low-power data communication systems such as this equipment overlaps that of mobile object identification systems (premises radio station and specified low-power radio station).

1. Sticker

Please put the following sticker on computer incorporating this product.

In the frequency bandwidth of this equipment, industrial device, scientific device, medical device like microwave oven, licensed premises radio station and non-licensed specified low-power radio station for mobile object identification system (RF-ID) that is used in product line of factories, (Other Radio Stations) are used.

1. Please make sure before using this equipment that no Other Radio Stations are used in the neighborhood.
2. In case that RF interference occurs to Other Radio Stations from this equipment, please change promptly the frequency for use, place to use, or stop emitting Radio.
3. Please contact TOSHIBA Direct PC if you have a problem, such as interference from this equipment to Other Radio Stations.

2. Indication

The indication shown below appears on this equipment.

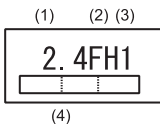

(1) 2.4 : This equipment uses a frequency of 2.4 GHz.

(2) FH : This equipment uses FH-SS modulation.

(3) 1: The interference range of this equipment is less than 10 m.

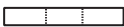
(4)  This equipment uses a frequency bandwidth from 2,400 MHz to 2,483.5 MHz.

It is impossible to avoid the band of mobile object identification systems.

3. TOSHIBA Direct PC

Monday - Friday: 10:00-17:00

Toll Free Tel : 0120-13-1100

Direct Dial : 03-3457-5916

FAX : 03-5444-9450

Device Authorization

This device obtains the Technical Regulation Conformity Certification and the Technical Conditions Compliance Approval, and it belongs to the device class of radio equipment of low-power data communication system radio station stipulated in the Radio Law and the Telecommunications Business of Japan.

The Name of the radio equipment: EYXF2CS

TELECOM ENGINEERING CENTER

Approval Number: 001NYDA1507

JAPAN APPROVALS INSTITUTE FOR TELECOMMUNICATIONS
EQUIPMENT

Approval Number: D04-0411001

The following restrictions apply:

Do not disassemble or modify the device.

Do not install the embedded wireless module into other device.

Approved Countries/Regions for use (Bluetooth™ wireless technology)

Bluetooth™ Card from TOSHIBA equipment is approved to the radio standard by the countries/regions in the following table.



Do not use this equipment except in the countries/regions in the following table.

Australia	Austria	Belgium
Canada	Denmark	Finland
Germany	Iceland	Ireland
Japan	Luxembourg	Netherlands
New Zealand	Norway	Sweden
Switzerland	UK	USA
Greece	Italy	France
Portugal	Spain	Liechtenstein

Countries/regions that have approved Bluetooth™ Card from TOSHIBA

Appendix E

AC Power Cord and Connectors

The power cord's AC input plug must be compatible with the various international AC power outlets and the cord must meet the standards for the country/region in which it is used. All cords must meet the following specifications:

Length:	Minimum 2 meters
Wire size:	Minimum 0.75 mm ²
Current rating:	Minimum 2.5 amperes
Voltage rating:	125 or 250 VAC (depending on country/region's power standards)

Certification agencies

U.S. and Canada:	UL listed and CSA certified No. 18 AWG, Type SVT or SPT-2		
Australia:	AS		
Japan:	DENANHO		
<i>Europe:</i>			
Austria:	OVE	Italy:	IMQ
Belgium:	CEBEC	The Netherlands:	KEMA
Denmark:	DEMKO	Norway:	NEMKO
Finland:	FIMKO	Sweden:	SEMKO
France:	LCIE	Switzerland:	SEV
Germany:	VDE	United Kingdom:	BSI

In Europe, two conductors power cord must be VDE type, H05VVH2-F or H03VVH2-F and for three conductors power cord must be VDE type, H05VV-F.

For the United States and Canada, two pin plug configuration must be a 2-15P (250V) or 1-15P (125V) and three pin plug configuration must be 6-15P (250V) or 5-15P (125V) as designated in the U.S. National Electrical code handbook and the Canadian Electrical Code Part II.

The following illustrations show the plug shapes for the U.S.A. and Canada, the United Kingdom, Australia and Europe.

USA

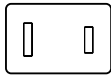

UL approved

United Kingdom

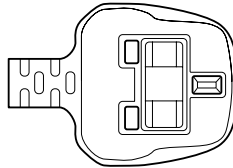

BS approved

Australia

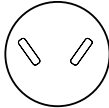

AS approved

Europe

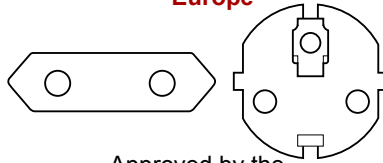

Approved by the appropriate agency

Canada



CSA approved

If your computer is stolen



Always take care of your computer and try to prevent it from being stolen. You are the owner of a valuable technical device, which may be highly attractive to thieves, so please do not leave it unattended in a public place. To further help protect against theft, security cables can be bought for use with your notebook when it is being used at home or in the office.

Make a note of your computer's machine type, model number, and serial number, and put it in a safe place. You will find this information on the underside of your notebook. Please also keep the receipt of the computer you purchased.

Should your computer be stolen, however, we'll help you try to find it. Before contacting TOSHIBA, please prepare the following information which is necessary to uniquely identify your computer:

- In which country was your computer stolen?
- What type of machine do you have?
- What was the model number (PA number)?
- What was the serial number (8 digits)?
- When was it stolen, i.e. date?
- What is your address, phone, and fax number?

To register the theft on paper, please follow these procedures:

- Fill in the TOSHIBA Theft Registration form (or a copy of it) below.
- Attach a copy of your receipt showing where your computer was purchased.
- Either fax or send the receipt and registration form to the address below.

To register the theft online, please follow these procedures:

- Visit www.toshiba-europe.com on the Internet. In the product area, choose **Computer Systems**.
- In the Computer Systems page, open the **Support & Downloads** menu and choose the **Stolen Units Database** option.

Your entries are used to track your computer at our service points.

TOSHIBA Theft Registration

Send to: TOSHIBA Europe GmbH
Technical Service and Support
Leibnizstr. 2
93055 Regensburg
Germany

Fax number: +49 (0) 941 7807 921

Country stolen:									
Machine type: (e.g. TOSHIBA Pocket PC e350)									
Model number: (e.g. PSA50 YXT)	<input type="text"/> <input type="text"/> <input type="text"/> <input type="text"/> <input type="text"/> <input type="text"/> <input type="text"/> <input type="text"/> <input type="text"/> <input type="text"/> <input type="text"/> <input type="text"/> <input type="text"/> <input type="text"/> <input type="text"/> <input type="text"/> <input type="text"/> <input type="text"/> <input type="text"/> <input type="text"/>								
Serial number: (e.g. 12345678G)	<input type="text"/> <input type="text"/> <input type="text"/> <input type="text"/> <input type="text"/> <input type="text"/> <input type="text"/> <input type="text"/> <input type="text"/> <input type="text"/>								
Date stolen:	<table><tr><td></td><td>Year</td><td>Month</td><td>Day</td></tr><tr><td><input type="text"/><input type="text"/><input type="text"/><input type="text"/></td><td></td><td><input type="text"/><input type="text"/></td><td><input type="text"/><input type="text"/></td></tr></table>		Year	Month	Day	<input type="text"/> <input type="text"/> <input type="text"/> <input type="text"/>		<input type="text"/> <input type="text"/>	<input type="text"/> <input type="text"/>
	Year	Month	Day						
<input type="text"/> <input type="text"/> <input type="text"/> <input type="text"/>		<input type="text"/> <input type="text"/>	<input type="text"/> <input type="text"/>						

Owner's details

Last name, first name:	
Company:	
Street:	
Postal Code/City:	
Country:	
Phone:	
Fax:	

Glossary

The terms in this glossary cover topics related to this manual. Alternate naming is included for reference.

Abbreviations

AC: alternating current

AGP: accelerated graphics port

ANSI: American National Standards Institute

APM: advanced power manager

ASCII: American Standard Code for Information Interchange

BIOS: basic input output system

CD-ROM: Compact Disc-Read Only Memory

CD-RW: Compact Disc-ReWritable

CMOS: complementary metal-oxide semiconductor

CPU: central processing unit

CRT: cathode ray tube

DC: direct current

DDC: display data channel

DMA: direct memory access

DOS: disk operating system

DVD: digital versatile disc

DVD-R: Digital Versatile Disc-Recordable

DVD-RAM: Digital Versatile Disc-Random Access Memory

DVD-ROM: Digital Versatile Disc-Read Only Memory

DVD-RW: Digital Versatile Disc-ReWritable

ECP: extended capabilities port

FDD: floppy disk drive

FIR: fast infrared

HDD: hard disk drive

IDE: integrated drive electronics

I/O: input/output

IrDA: Infrared Data Association
IRQ: interrupt request
KB: kilobyte
LCD: liquid crystal display
LED: light emitting diode
LSI: large scale integration
MB: megabyte
MS-DOS: Microsoft Disk Operating System
OCR: optical character recognition (reader)
PCB: printed circuit board
PCI: peripheral component interconnect
RAM: random access memory
RGB: red, green, and blue
ROM: read only memory
RTC: real time clock
SCSI: small computer system interface
SIO: serial input/output
SXGA+: super extended graphics array plus
TFT: thin-film transistor
UART: universal asynchronous receiver/transmitter
USB: Universal Serial Bus
UXGA: ultra extended graphics array
VESA: Video Electronic Standards Association
VGA: video graphics array
VRT: voltage reduction technology
WXGA: wide extended graphics array
XGA: extended graphics array

A

adaptor: A device that provides an interface between two dissimilar electronic devices. For example, the AC adaptor modifies the power from a wall outlet for use by the computer. This term also refers to the add-in circuit cards that control external devices, such as video monitors and magnetic tape devices.

allocate: To assign a space or function for a specific task.

alphanumeric: Keyboard characters including letters, numbers and other symbols, such as punctuation marks or mathematical symbols.

alternating current (AC): Electric current that reverses its direction of flow at regular intervals.

- analog signal:** A signal whose characteristics such as amplitude and frequency vary in proportion to (are an analog of) the value to be transmitted. Voice communications are analog signals.
- ANSI:** American National Standards Institute. An organization established to adopt and define standards for a variety of technical disciplines. For example, ANSI defined the ASCII standard and other information processing requirements.
- antistatic:** A material used to prevent the buildup of static electricity.
- application:** A group of programs that together are used for a specific task such as accounting, financial planning, spreadsheets, word processing and games.
- ASCII:** American Standard Code for Information Interchange. ASCII code is a set of 256 binary codes that represent the most commonly used letters, numbers, and symbols.
- async:** Short for asynchronous.
- asynchronous:** Lacking regular time relationship. As applied to computer communications, asynchronous refers to the method of transmitting data that does not require a steady stream of bits to be transmitted at regular time intervals.

B

- backup:** A duplicate copy of files kept as a spare in case the original is destroyed.
- batch file:** A file that can be executed from the system prompt containing a sequence of operating system commands or executable files.
- binary:** The base two number system composed of zeros and ones (off or on), used by most digital computers. The right-most digit of a binary number has a value of 1, the next a value of 2, then 4, 8, 16, and so on. For example, the binary number 101 has a value of 5. *See also* ASCII.
- BIOS:** Basic Input Output System. The firmware that controls data flow within the computer. *See also* firmware.
- bit:** Derived from "binary digit," the basic unit of information used by the computer. It is either zero or one. Eight bits is one byte. *See also* byte.
- board:** A circuit board. An internal card containing electronic components, called chips, which perform a specific function or increase the capabilities of the system.
- boot:** Short for bootstrap. A program that starts or restarts the computer. The program reads instructions from a storage device into the computer's memory.
- bps:** Bits per second. Typically used to describe the data transmission speed of a modem.
- buffer:** The portion of the computer's memory where data is temporarily stored. Buffers often compensate for differences in the rate of flow from one device to another.

bus: An interface for transmission of signals, data or electric power.

byte: The representation of a single character. A sequence of eight bits treated as a single unit; also the smallest addressable unit within the system.

C

cache memory: High speed memory which stores data that increases processor speed and data transfer rate. When the CPU reads data from main memory, it stores a copy of this data in cache memory. The next time the CPU needs that same data, it looks for it in the cache memory rather than the main memory, which saves time. The computer has two cache levels. Level one is incorporated into the processor and level two resides in external memory.

capacity: The amount of data that can be stored on a magnetic storage device such as a floppy disk or hard disk. It is usually described in terms of kilobytes (KB), where one KB = 1024 bytes and megabytes (MB), where one MB = 1024 KB.

card: Synonym for board. See board.

CardBus: An industry standard bus for 32-bit PC cards.

CD-ROM: A Compact Disc-Read Only Memory is a high capacity disc that can be read from but not written to. The CD-ROM drive uses a laser, rather than magnetic heads, to read data from the disc.

CD-R: A Compact Disc-Recordable disc can be written once and read many times. See also CD-ROM.

CD-RW: A Compact Disc-ReWritable disc can be rewritten many times. See also CD-ROM.

character: Any letter, number, punctuation mark, or symbol used by the computer. Also synonymous with byte.

chassis: The frame containing the computer.

chip: A small semiconductor containing computer logic and circuitry for processing, memory, input/output functions and controlling other chips.

CMOS: Complementary Metal-Oxide Semiconductor. An electronic circuit fabricated on a silicon wafer that requires very little power. Integrated circuits implemented in CMOS technology can be tightly packaged and are highly reliable.

cold start: Starting a computer that is currently off (turning on the power).

COM1, COM2, COM3 and COM4: The names assigned to the serial and communication ports.

commands: Instructions you enter at the terminal keyboard that direct the actions of the computer or its peripheral devices.

communications: The means by which a computer transmits and receives data to and from another computer or device. See parallel interface; serial interface.

- compatibility:** 1) The ability of one computer to accept and process data in the same manner as another computer without modifying the data or the media upon which it is being transferred.
2) the ability of one device to connect to or communicate with another system or component.
- components:** Elements or parts (of a system) which make up the whole (system).
- computer program:** A set of instructions written for a computer that enable it to achieve a desired result.
- computer system:** A combination of hardware, software, firmware, and peripheral components assembled to process data into useful information.
- configuration:** The specific components in your system (such as the terminal, printer, and disk drives) and the settings that define how your system works. You use the HW Setup program to control your system configuration.
- control keys:** A key or sequence of keys you enter from the keyboard to initiate a particular function within a program.
- controller:** Built-in hardware and software that controls the functions of a specific internal or peripheral device (e.g. keyboard controller).
- co-processor:** A circuit built into the processor that is dedicated to intensive math calculations.
- CPS:** Characters Per Second. Typically used to indicate the transmission speed of a printer.
- CPU:** Central Processing Unit. The portion of the computer that interprets and executes instructions.
- CRT:** Cathode Ray Tube. A vacuum tube in which beams projected on a fluorescent screen-producing luminous spots. An example is the television set.
- cursor:** A small, blinking rectangle or line that indicates the current position on the display screen.

D

- data:** Information that is factual, measurable or statistical that a computer can process, store, or retrieve.
- data bits:** A data communications parameter controlling the number of bits (binary digits) used to make up a byte. If data bits = 7 the computer can generate 128 unique characters. If data bits = 8 the computer can generate 256 unique characters.
- DC:** Direct Current. Electric current that flows in one direction. This type of power is usually supplied by batteries.
- default:** The parameter value automatically selected by the system when you or the program do not provide instructions. Also called a preset value.

- delete:** To remove data from a disk or other data storage device.
Synonymous with erase.
- device driver:** A program that controls communication between a specific peripheral device and the computer. The CONFIG.SYS file contains device drivers that MS-DOS loads when you turn the computer on.
- dialog box:** A window that accepts user input to make system settings or record other information.
- disk drive:** The device that randomly accesses information on a disk and copies it to the computer's memory. It also writes data from memory to the disk. To accomplish these tasks, the unit physically rotates the disk at high speed past a read-write head.
- disk storage:** Storing data on magnetic disk. Data is arranged on concentric tracks much like a phonograph record.
- display:** A CRT, LCD, or other image producing device used to view computer output.
- documentation:** The set of manuals and/or other instructions written for the users of a computer system or application. Computer system documentation typically includes procedural and tutorial information as well as system functions.
- DOS:** Disk Operating System. See operating system.
- driver:** A software program, generally part of the operating system, that controls a specific piece of hardware (frequently a peripheral device such as a printer or mouse).
- DVD-R (+R, -R):** A Digital Versatile Disc-Recordable disk can be written once and read many times. The DVD-R drive uses a laser to read data from the disc.
- DVD-RAM:** A Digital Versatile Disc-Random Access Memory is a high-capacity, high performance disc that lets you store large volumes of data. The DVD-ROM drive uses a laser to read data from the disc.
- DVD-ROM:** A Digital Versatile Disc-Read Only Memory is a high capacity, high performance disc suitable for play back of video and other high-density files. The DVD-ROM drive uses a laser to read data from the disc.
- DVD-RW (+RW, -RW):** A Digital Versatile Disc-ReWritable disc can be rewritten many times.

E

- echo:** To send back a reflection of the transmitted data to the sending device. You can display the information on the screen, or output it to the printer, or both. When a computer receives back data it transmitted to a CRT (or other peripheral device) and then retransmits the data to printer, the printer is said to echo the CRT.
- erase:** See delete.

escape: 1) A code (ASCII code 27), signaling the computer that what follows are commands; used with peripheral devices such as printers and modems.

2) A means of aborting the task currently in progress.

escape guard time: A time before and after an escape code is sent to the modem which distinguishes between escapes that are part of the transmitted data, and escapes that are intended as a command to the modem.

execute: To interpret and execute an instruction.

Extended Capability Port: An industry standard that provides a data buffer, switchable forward and reverse data transmission, and run length encoding (RLE) support.

F

fast infrared: An industry standard that enables cableless infrared serial data transfer at speeds of up to 4 Mbps.

file: A collection of related information; a file can contain data, programs, or both.

firmware: A set of instructions built into the hardware which controls and directs a microprocessor's activities.

floppy disk: A removable disk that stores magnetically encoded data.

floppy disk drive (FDD): An electromechanical device that reads and writes to floppy disks.

Fn-esse: A TOSHIBA utility that lets you assign functions to hot keys.

folder: An icon in Windows used to store documents or other folders.

format: The process of readying a blank disk for its first use. Formatting establishes the structure of the disk that the operating system expects before it writes files or programs onto the disk.

function keys: The keys labeled **F1** through **F12** that tell the computer to perform certain functions.

G

gigabyte (GB): A unit of data storage equal to 1024 megabytes. *See also* megabyte.

graphics: Drawings, pictures, or other images, such as charts or graphs, to present information.

H

hard disk: A non-removable disk usually referred to as drive C. The factory installs this disk and only a trained engineer can remove it for servicing. Also called fixed disk.

hard disk drive (HDD): An electromechanical device that reads and writes a hard disk. *See also* hard disk.

- hardware:** The physical electronic and mechanical components of a computer system: typically, the computer itself, external disk drives, etc. See *also* software and firmware.
- hertz:** A unit of wave frequency that equals one cycle per second.
- hexadecimal:** The base 16 numbering system composed of the digits 0 through 9 and the letters A, B, C, D, E, and F.
- host computer:** The computer that controls, regulates, and transmits information to a device or another computer.
- hot key:** The computer's feature in which certain keys in combination with the extended function key, **Fn**, can be used to set system parameters, such as speaker volume.
- HW Setup:** A TOSHIBA utility that lets you set the parameters for various hardware components.

I

- icon:** A small graphic image displayed on the screen or in the indicator panel. In Windows, an icon represents an object that the user can manipulate.
- i.LINK (IEEE1394):** This port enables high-speed data transfer directly from external devices such as digital video cameras.
- infrared port:** A cableless communications port capable of using infrared signals to send serial data.
- input:** The data or instructions you provide to a computer, communication device or other peripheral device from the keyboard or external or internal storage devices. The data sent (or output) by the sending computer is input for the receiving computer.
- instruction:** Statements or commands that specify how to perform a particular task.
- interface:** 1) Hardware and/or software components of a system used specifically to connect one system or device to another.
2) To physically connect one system or device to another to exchange information.
3) The point of contact between user, the computer, and the program, for example, the keyboard or a menu.
- interrupt request:** A signal that gives a component access to the processor.
- I/O:** Input/output. Refers to acceptance and transfer of data to and from a computer.
- I/O devices:** Equipment used to communicate with the computer and transfer data to and from it.
- IrDA 1.1:** An industry standard that enables cableless infrared serial data transfer at speeds of up to 4 Mbps.

J

jumper: A small clip or wire that allows you to change the hardware characteristics by electrically connecting two points of a circuit.

K

K: Taken from the Greek word kilo, meaning 1000; often used as equivalent to 1024, or 2 raised to the 10th power. *See also* byte and kilobyte.

KB: *See* kilobyte.

keyboard: An input device containing switches that are activated by manually pressing marked keys. Each keystroke activates a switch that transmits a specific code to the computer. For each key, the transmitted code is, in turn, representative of the (ASCII) character marked on the key.

kilobyte (KB): A unit of data storage equal to 1024 bytes. *See also* byte and megabyte.

L

level 2 cache: *See* cache.

Light Emitting Diode (LED): A semiconductor device that emits light when a current is applied.

Liquid Crystal Display (LCD): Liquid crystal sealed between two sheets of glass coated with transparent conducting material. The viewing-side coating is etched into character forming segments with leads that extend to the edge of the glass. Applying a voltage between the glass sheets alters the brightness of the liquid crystal.

LSI: Large Scale Integration.

- 1) A technology that allows the inclusion of up to 100,000 simple logic gates on a single chip.
- 2) An integrated circuit that uses large scale integration.

M

main board: *See* motherboard.

megabyte (MB): A unit of data storage equal to 1024 kilobytes. *See also* kilobyte.

megahertz: A unit of wave frequency that equals 1 million cycles per second. *See also* hertz.

menu: A software interface that displays a list of options on the screen. Also called a screen.

microprocessor: A hardware component contained in a single integrated circuit that carries out instructions. Also called the central processing unit (CPU), one of the main parts of the computer.

mode: A method of operation, for example, the boot mode, standby mode or the hibernation mode.

modem: Derived from modulator/demodulator, a device that converts (modulates) digital data for transmission over telephone lines and then converts modulated data (demodulates) to digital format where received.

monitor: A device that uses rows and columns of pixels to display alphanumeric characters or graphic images. *See also* CRT.

motherboard: A name sometimes used to refer to the main printed circuit board in processing equipment. It usually contains integrated circuits that perform the processor's basic functions and provides connectors for adding other boards that perform special functions. Sometimes called a main board.

MP3: An audio compression standard that enables high-quality transmission and real-time playback of sound files.

N

non-system disk: A formatted floppy disk you can use to store programs and data but you cannot use to start the computer. *See* system disk.

nonvolatile memory: Memory, usually read-only (ROM), that is capable of permanently storing information. Turning the computer's power off does not alter data stored in nonvolatile memory.

numeric keypad overlay: A feature that allows you to use certain keys on the keyboard to perform numeric entry, or to control cursor and page movement.

O

OCR: Optical Character Recognition (reader). A technique or device that uses laser or visible light to identify characters and input them into a storage device.

online state: A functional state of a peripheral device when it is ready to receive or transmit data.

operating system: A group of programs that controls the basic operation of a computer. Operating system functions include interpreting programs, creating data files, and controlling the transmission and receipt (input/output) of data to and from memory and peripheral devices.

output: The results of a computer operation. Output commonly indicates data.
1) printed on paper, 2) displayed at a terminal, 3) sent through the serial port of internal modem, or 4) stored on some magnetic media.

P

parallel interface: Refers to a type of information exchange that transmits information one byte (8 bits) at a time. *See also* serial interface.

parity: 1) The symmetrical relationship between two parameter values (integers) both of which are either on or off; odd or even; 0 or 1.
2) In serial communications, an error detection bit that is added to a group of data bits making the sum of the bits even or odd. Parity can be set to none, odd, or even.

password: A unique string of characters used to identify a specific user. The computer provides various levels of password protection such as user, supervisor and eject.

pel: The smallest area of the display that can be addressed by software. Equal in size to a pixel or group of pixels. *See* pixel.

peripheral component interconnect: An industry standard 32-bit bus.

peripheral device: An I/O device that is external to the central processor and/or main memory such as a printer or a mouse.

pixel: A picture element. The smallest dot that can be made on a display or printer. Also called a pel.

plug and play: A capability with Windows that enables the system to automatically recognize connections of external devices and make the necessary configurations in the computer.

port: The electrical connection through which the computer sends and receives data to and from devices or other computers.

Power Saver Utility: A TOSHIBA utility that lets you set the parameters for various power-saving functions.

printed circuit board (PCB): A hardware component of a processor to which integrated circuits and other components are attached. The board itself is typically flat and rectangular, and constructed of fiberglass, to form the attachment surface.

program: A set of instructions a computer can execute that enables it to achieve a desired result. *See also* application.

prompt: A message the computer provides indicating it is ready for or requires information or an action from you.

R

Radio frequency interference (RFI) shield: A metal shield enclosing the printed circuit boards of the printer or computer to prevent radio and TV interference. All computer equipment generates radio frequency signals. The FCC regulates the amount of signals a computing device can allow past its shielding. A Class A device is sufficient for office use. Class B provides a more stringent classification for home equipment use. TOSHIBA portable computers comply with Class B computing device regulations.

Random Access Memory (RAM): High speed memory within the computer circuitry that can be read or written to.

- restart:** Resetting a computer without turning it off (also called “warm boot” or “soft reset”). *See also* boot.
- RGB:** Red, green, and blue. A device that uses three input signals, each activating an electron gun for a primary additive color (red, green, and blue) or port for using such a device. *See also* CRT.
- RJ11:** A modular telephone jack.
- RJ45:** A modular LAN jack.
- ROM:** Read Only Memory: A nonvolatile memory chip manufactured to contain information that controls the computer’s basic operation. You cannot access or change information stored in ROM.

S

- SCSI:** Small Computer System Interface is an industry standard interface for connection of a variety of peripheral devices.
- SD card:** Secure Digital cards are flash memory widely used in a variety of digital devices such as digital cameras and Personal Digital Assistants.
- serial communications:** A communications technique that uses as few as two interconnecting wires to send bits one after another.
- serial interface:** Refers to a type of information exchange that transmits information sequentially, one bit at a time. Contrast: Parallel interface.
- SIO:** Serial Input/Output. The electronic methodology used in serial data transmission.
- soft key:** Key combinations that emulate keys on the IBM keyboard, change some configuration options, stop program execution, and access the numeric keypad overlay.
- software:** The set of programs, procedures and related documentation associated with a computer system. Specifically refers to computer programs that direct and control the computer system’s activities. *See also* hardware.
- stop bit:** One or more bits of a byte that follow the transmitted character or group codes in asynchronous serial communications.
- subpixel:** Three elements, one red, one green and blue (RGB), that make up a pixel on the color LCD. The computer sets subpixels independently, each may emit a different degree of brightness. *See also* pixel.
- synchronous:** Having a constant time interval between successive bits, characters or events.
- system disk:** A disk that has been formatted with an operating system. For MS-DOS the operating system is contained in two hidden files and the COMMAND.COM file. You can boot a computer using a system disk. Also called an operating system disk.

T

terminal: A typewriter-like keyboard and CRT display screen connected to the computer for data input/output.

TFT display: A liquid crystal display (LCD) made from an array of liquid crystal cells using active-matrix technology with thin film transistor (TFT) to drive each cell.

Touch Pad: A pointing device integrated into the TOSHIBA computer palm rest.

TTL: Transistor-transistor logic. A logic circuit design that uses switching transistors for gates and storage.

U

Universal Serial Bus: This serial interface lets you communicate with several devices connected in a chain to a single port on the computer.

V

VGA: Video Graphics Array is an industry standard video adaptor that lets you run any popular software.

volatile memory: Random access memory (RAM) that stores information as long as power is supplied to the computer.

W

warm start: Restarting or resetting a computer without turning it off.

window: A portion of the screen that can display its own application, document or dialog box. Often used to mean a Microsoft Windows window.

Wireless LAN: Local Area Network (LAN) through wireless communication.

write protection: A method for protecting a floppy disk from accidental erasure.

Index

A

- AC adaptor 4
 - additional 15, 10
 - connecting 4
 - DC IN 15V jack 5
- Advanced Port Replicator III 16, 14
- ASCII characters 9

B

- Battery
 - charging 8
 - extending life 11
 - indicator 10, 2
 - location 6
 - monitoring capacity 9
 - real time clock 4, 5
 - safety precautions 5
 - save mode 11
 - types 3
- Battery charger 15, 10
- Battery pack 4, 6
 - additional 10
 - replacing 12
- Bluetooth 8, 23
 - problems 19
 - TOSHIBA Stack 13
- Boot Priority 2

C

- CF card 7, 5
 - care 7
 - inserting 6
 - location of slot 3
 - problems 12
 - removing 6
- Cleaning the computer 27
- Cooling vents 2

D

- DC IN indicator 10, 3
- Display 6, 8
 - automatic power off 10
 - brightness decrease 5
 - brightness increase 5
 - controller 6, 1
 - hinge 8
 - opening 6
- DLA for TOSHIBA 14
- Docking interface 6
- Documentation list 2
- DVD Super Multi drive 5
 - location of slot 3
 - problems 10
 - using 3
 - writing 9

DVD-ROM&CD-R/RW drive 5
location of slot 3
problems 9
using 3
writing 7

E

Environment 1
Equipment checklist 1
Equipment setup
general conditions 2
placement 2
Ergonomics
lighting 3
seating and posture 3
work habits 4

F

Floppy disk care 17
Fn + Ctrl (enhanced keyboard simulation) 3
Fn + Enter 3
Fn + Esc (sound mute) 3
Fn + F1 (instant security) 4
Fn + F10 (Arrow mode) 3
Fn + F11 (Numeric mode) 3
Fn + F12 (ScrLock) 3
Fn + F2 (power save mode) 4
Fn + F5 (display selection) 5
Fn + F6 (display brightness) 5
Fn + F7 (display brightness) 5
Fn + F8 (wireless setting) 5
Fn + F9 (Touch Pad) 6
Fn + Space (LCD screen resolution selection) 6
Fn + Tab (Optical media drive power icon) 6
Function keys 2

G

Graphics controller 6

H

Hard disk drive 4
automatic power off 10
HDD indicator 10
Heat dispersal 11, 28
Hibernation 12, 4
High capacity battery 15, 4
Hot keys 10
display brightness
decrease 5
display brightness
increase 5
display selection 5
instant security 4
power save mode 4
sound mute 3
standby 4
wireless setting 5

HW Setup 13
accessing 1
boot priority 2
CPU 5
Device Config 6
display 2
general 2
keyboard 4
LAN 6
Parallel/Printer 6
USB 7
window 1

I

i.LINK 6, 4, 12
connecting 13
disconnecting 13
precautions 12
problems 17
Indicators 10, 2
Infrared port 7
location 1
problems 12

K

- Keyboard 6, 1
 - emulating enhanced key-board 2
 - Fn Sticky key 6
 - Function keys F1...F12 2
 - hot keys 3
 - problems 7
 - typewriter keys 1
 - Windows special keys 7
- Keypad overlay 10, 7
 - Arrow mode 7
 - Numeric mode 8
 - temporarily using normal keyboard (overlay on) 8
 - temporarily using overlay (overlay off) 8
 - turning on the overlays 7

L

- LAN 8, 25
 - cable types 25
 - connecting 26
 - disconnecting 26
 - jack 5
 - LAN active indicator 5
 - Link indicator 5
 - problems 18

M

- Media care 17
 - CD/DVDs 17
 - floppy disks 17
 - SD card 5
- Memory 3
 - expansion 15, 7
 - installing 8
 - problems 15
 - removing 9

- Modem 8, 19
 - connecting 20
 - disconnecting 21
 - jack 4
 - problems 17
 - properties menu 19
 - region selection 19

- Monitor
 - external 6, 3, 11
 - problems 16

- Moving the computer 27

O

- Optical media drive 4

P

- Password
 - power on 10
 - problems 7
 - starting the computer by 16
 - Supervisor 16
 - user 14
- PC card 7, 2
 - inserting 2
 - location of slot 2
 - problems 12
 - removing 2
- Pointing Device 6
 - problems 13
 - Touch Pad 6, 8
 - Touch Pad control buttons 8
 - Touch Pad location 7
 - using 1
- Ports
 - Docking interface 6
 - external monitor 6
 - i.LINK 6
 - infrared 7
 - USB 6

- Power
 - button location 7
 - conditions 1
 - hibernation mode 8
 - indicators 2
 - panel on/off 11, 17
 - problems 4
 - shut down mode
 - (boot mode) 8
 - standby mode 10
 - system auto off 17
 - turning off 8
 - turning on 7
 - Power-up modes 17
 - Printer
 - parallel 6, 15
 - Problems
 - AC power 5
 - Analyzing symptoms 2
 - Battery 5
 - Bluetooth 19
 - CF card 12
 - DVD Super Multi drive 10
 - DVD-ROM&CD-R/RW drive
 - 9
 - External monitor 16
 - Hard disk drive 8
 - Hardware and system
 - checklist 3
 - i.LINK 17
 - Infrared port 12
 - Internal LCD panel 8
 - Keyboard 7
 - LAN 18
 - Memory expansion 15
 - Modem 17
 - mouse, USB 14
 - Overheating power down 4
 - Password 7
 - PC card 12
 - Pointing Device 13
 - Power 4
 - SD card 11
 - Self test 3
 - Sound System 16
 - support from TOSHIBA 20
 - System start-up 3
 - Touch Pad 13
 - USB 15
 - USB floppy disk drive 11
 - Wireless LAN 18
 - Processor 3
- R**
- RecordNow! 14, 12
 - Recovery HDD 13
 - Recovery Media 13
 - Restarting the computer 11
- S**
- SD card 7, 3
 - care 5
 - indicator 10
 - inserting 4
 - location of slot 3
 - problems 11
 - removing 4
 - Security lock 15
 - attaching 16
 - location 2, 3
 - Soft keys
 - enhanced keyboard 2
 - Enter 3
 - right Ctrl key 3
 - ScrLock 3
 - Sound System 18
 - headphone jack 7, 2
 - microphone jack 7, 2
 - mute hot keys 3
 - problems 16
 - speakers 8
 - volume control 2
 - Standby 12
 - setting 10
 - System automatic 10

T

- TOSHIBA Assist 14
- TOSHIBA Assist button 10
- TOSHIBA ConfigFree 14
- TOSHIBA Controls 13
- TOSHIBA Mobile Extension 14
- TOSHIBA PC Diagnostic Tool 14
- TOSHIBA Power Saver 13
- TOSHIBA Presentation button 10
- TOSHIBA SD Memory Boot Utility 13
- TOSHIBA Theft Registration 2
- TOSHIBA Zooming Utility 13

U

- USB 6
 - location 2, 3
 - problems 15
- USB floppy disk drive 4
 - additional 11
 - problems 11
 - using 2

V

- Video modes 1
- Video RAM 3
- Volume control 2

W

- Wireless communication 21
 - indicator 10, 25
 - switch 9, 2, 24
- Wireless LAN 9, 22, 1
 - problems 18

