

Touchmonitor User Guide

1928L 19" LCD Desktop Touchmonitor
5000 Series



User Guide

1928L 19" LCD Desktop Touchmonitor

Revision B

P/N E116103

Copyright © 2007 Tyco Electronics Corporation. All Rights Reserved.

No part of this publication may be reproduced, transmitted, transcribed, stored in a retrieval system, or translated into any language or computer language, in any form or by any means, including, but not limited to, electronic, magnetic, optical, chemical, manual, or otherwise without prior written permission of Elo TouchSystems.

Disclaimer

The information in this document is subject to change without notice. Elo TouchSystems makes no representations or warranties with respect to the contents hereof, and specifically disclaims any implied warranties of merchantability or fitness for a particular purpose. Elo TouchSystems reserves the right to revise this publication and to make changes from time to time in the content hereof without obligation of Elo TouchSystems to notify any person of such revisions or changes.

Trademark Acknowledgments

Elo Touchsystems AccuTouch and IntelliTouch are trademarks of Tyco Electronics Corporation. Other product names mentioned herein may be trademarks or registered trademarks of their respective companies.

Warnings and Cautions



Warning

- Danger - Explosion hazard. Do not use in the presence of flammable anesthetics, and other flammable materials.
- To prevent fire or shock hazards, do not immerse the unit in water or expose it to rain or moisture.
- Do not use the unit with an extension cord receptacle or other outlets unless the prongs of the power cord can be fully inserted.
- RISK OF ELECTRICAL SHOCK - DO NOT OPEN. To reduce the risk of electrical shock, DO NOT remove the back of the equipment or open the enclosure. No user-serviceable parts are inside. Refer servicing to qualified field service engineers only.
- Uninsulated voltage within the unit may have sufficient magnitude to cause electrical shock. Avoid contact with any part inside the unit.

Caution

- Power cord is used as a disconnection device. To de-energize equipment, disconnect the power cord.
- This unit must follow the national requirement, and local state laws to dispose unit.
- Before connecting the cables to your Elo touchmonitor, make sure all components are powered OFF.
- The use of ACCESSORY equipment not complying with the equivalent safety requirements of this equipment may lead to a reduced safety of the resulting system. Consideration relating to the choices of accessory equipment should include:
- Use of accessory in the patient vicinity.
- Evidence that the safety certification of the accessory has been performed in accordance to the appropriate IEC 60601-1 and/or IEC 60601-1-1 harmonized national standard.
- For continued safety -
 - This unit only complies to the above standards if used with a medical grade power cord.
 - A medical grade power supply, such as the one specified, is required for use in a medical application.



Note:

- This symbol alerts the user to important information concerning the operation and maintenance of this unit, which should be read carefully to avoid problems.
- This symbol means DC Current.
- This symbol means ON/OFF stand-by switch.





CAUTION-Life Support

Care must be taken when this touchmonitor is a critical component of a life support system or device. In case of failure of this touchmonitor, appropriate redundant systems should be incorporated into the system or device to prevent injury to the user or patient.

The following should be an integral part of the safety design of a life support system or device using this touchmonitor for a critical function.

- An alternate interface or fail-safe must be available should the touchscreen fail to operate.
- The touchscreen interface must not be the only means of control of a critical function.
- An alternate video display should be incorporated into the safety design if used to monitor a critical function.
- The internal speakers of this touchscreen monitor must not be the sole method of warning of a critical function.

Critical functions are:

1. Life support devices or systems are devices or systems which, (a) are intended for surgical implant into the body, or (b) support or sustain life, or (c) whose failure to perform when properly used in accordance with instructions for use provided in the labeling, can be reasonably expected to result in significant injury to the user.
2. A critical component is any component of a life support device or system whose failure to perform can be reasonably expected to cause the failure of the life support device or system, or to affect its safety or effectiveness.

Classification



With respect to electrical shock, fire in accordance with UL60601-1 and CAN/CSA C22.2 No. 60601-1

This monitor is a CLASS 1 (GROUNDED) DEVICE.

These displays are classified NO APPLIED PARTS EQUIPMENT.

Protection against harmful ingress of water:

INGRESS PROTECTION(IPX1)

This monitor shall be classified as ORDINARY EQUIPMENT, not intended or evaluated for use in the presence of flammable anesthetic mixture with air, oxygen, or nitrous oxide.

Mode of Operation: CONTINUOUS OPERATION.

Environmental conditions for transport and storage

Temp.	Operating	0°C to 40°C
	Storage / Transportation	-20°C to +60°C
Humidity (non-condensing)	Operating	30% to 70%
	Storage / Transportation	10% to 90%
	Altitude	Operating
	Storage / Transportation	0 to 40,000ft(12,192m) Equivalent to 1013-303 hP.A (14.7 to 4.4 psia)

For full Product Specifications refer to Appendix C

Table of Contents

Warnings and Cautions	iv	Appendix A	
Caution-Life Support	v	NATIVE RESOLUTION	19
Classification	vi		
 		Appendix B	
Chapter 1		TOUCHMONITOR SAFETY	21
INTRODUCTION	1	Care and Handling of Your Touchmonitor	22
Product Description	1		
LCD Display Performance Features	2	Appendix C	
19 inch TFT LCD Display Panel	2	TECHNICAL SPECIFICATIONS	23
External Medical Grade Power Supply	2	Display Modes	23
		Touchmonitor Specifications	24
Chapter 2		Power Supply Cord Selection	25
INSTALLATION AND SETUP	3	North America	25
Unpacking Your Touchmonitor	3	Cord selection for other than North America	26
Product Overview	4	AccuTouch (resistive) Touchscreen Specifications	28
Main Unit	4	IntelliTouch (resistive) Touchscreen Specifications	29
Back Unit	4		
Side View	4	Appendix D	
Base Bottom View	5	CONTACT ELO	31
Kensington™ Lock	5	Contact Elo	31
Touch Interface Connection	6	Replacement Parts	31
Step 1 Connecting the Video Cable	6		
Step 2 Connecting the Serial/USB Cable	7	REGULATORY INFORMATION	33
Step 3 Connecting the Speaker Cable	8		
Step 4 Connecting the Power Cable	9	WARRANTY	35
Optimizing the LCD Display	10		
Installing the Touch Driver Software	10	INDEX	37
Chapter 3			
OPERATION	11		
About Touchmonitor Adjustments	11		
Front Panel Controls	12		
Controls and Adjustment	13		
OSD Menu Functions	13		
OSD Control Options	14		
Power LED Display & Power Saving	15		
General Power Saving Mode	15		
Display Angle	15		
Chapter 4			
TROUBLESHOOTING	17		
Solutions to Common Problems	17		

1

INTRODUCTION

Product Description

The 1928L is a medical display designed to present information to the operator and the customer. The 1928L is available in serial and USB(combo) touch interface as well as no touch. The 1928L functionally consists of a 19" LCD main display with a touchscreen. The main display element is a 19" diagonal SXGA resolution (1280 x 1024) LCD display. The display consists of an LCD display and touchscreen. The 1928L is powered by 12 VDC from an external medical grade power source.

LCD Display Performance Features

19" TFT LCD Display Panel

Display format	1280 x 1024
Display area	376.32 mm (H) x 301.056 mm (V)
Pixel pitch	0.294 mm (H) x 0.294 mm (V)
Contrast Ratio	1300:1 (typical)
Brightness	
LCD	300 cd/m ² (typical)
AccuTouch	246 cd/m ² (typical)
IntelliTouch	276 cd/m ² (typical)
Accutouch transmission	82% (typical)
Intellitouch transmission	92% (typical)
Response time	Tr = 15 msec / Tf = 5 msec typical; 12 ms gray to gray response
Display color	16.7 million colors
Typical vertical viewing angle	89 deg (down) / 89 deg (up)
Typical horizontal viewing angle	89 deg (left) / 89 deg (right)

External Medical Grade Power Supply

The 1928L is powered by an external medical grade universal input AC power source.

Power supply:

- AC power: Input voltage 100 -240 VAC, 1.0A
- Input frequency 50/60 Hz
- DC output Voltage/Current: 12 VDC/4.0A
- Load regulation: ±5% Max.
- Line regulation: ±1% Max.

2

INSTALLATION AND SETUP

This chapter discusses how to install your LCD touchmonitor and how to install Elo TouchSystems driver software.

Unpacking Your Touchmonitor

Check that the following items are present and in good condition:

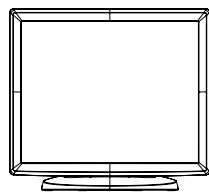

LCD monitor

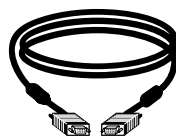

VGA cable

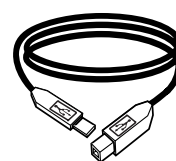

USB cable

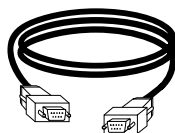

Serial Cable

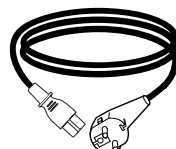

European power cable

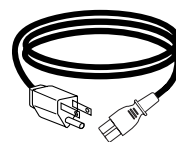

Power cable US/Canada

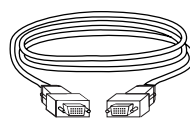

DVI Cable

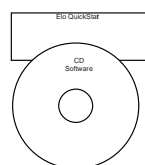

CD and Quick Install Guide

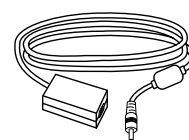

Power adaptor

Product Overview

Main Unit

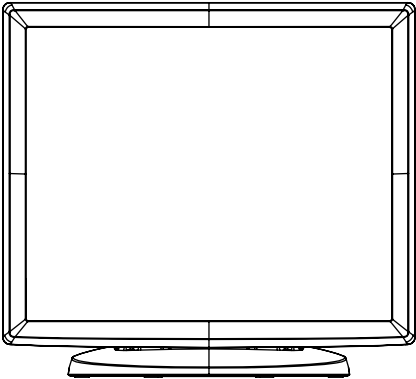

Back Unit

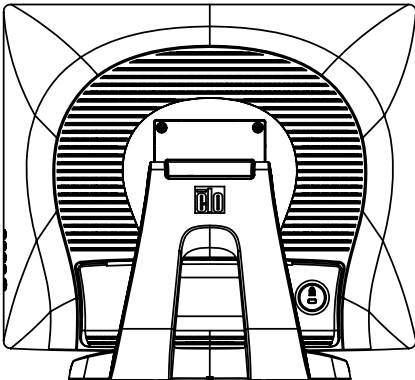

Side View

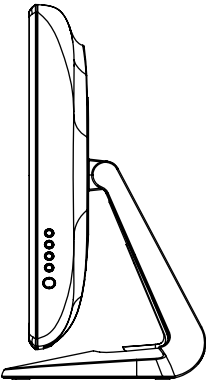

Base Bottom View

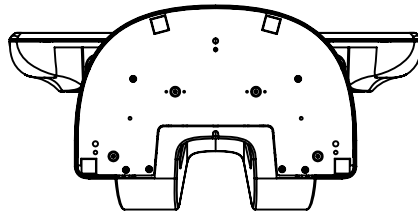

Kensington™ Lock



The Kensington™ lock is a security device that prevents theft. To find out more about this security device, go to <http://www.kensington.com>.

Touch Interface Connection

Note: Before connecting the cables to your touchmonitor and PC, be sure that the computer and touchmonitor are turned off.

STEP 1-Connecting the Video Cable

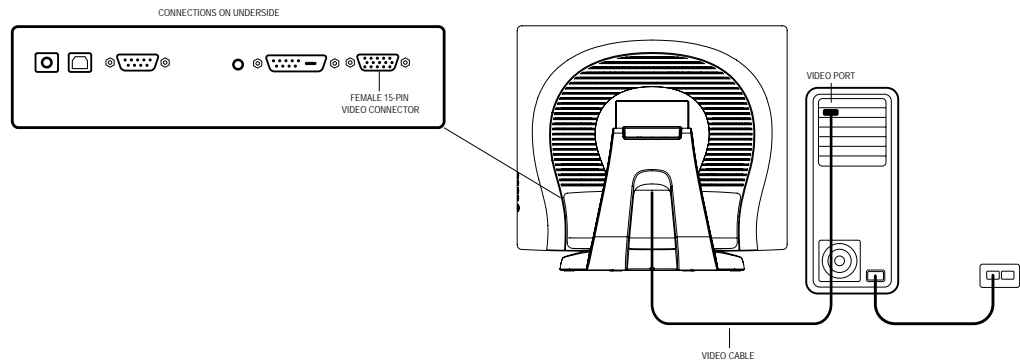

- Tilt the screen up and back to access the connection ports.
- Connect the 15-pin video cable (the ferrite bead end) or 24-pin DVI-D cable to the video port on your PC.
- Connect the other end of the video cable to the video connector on your touchmonitor.
- Secure the cable to your touchmonitor and PC by turning the screws on the connector clockwise.

STEP 2-Connecting the Serial and USB Touchscreen Cable

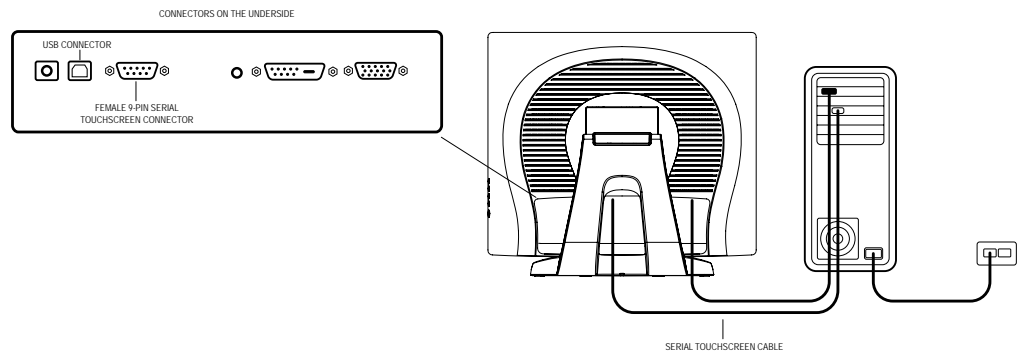

- Connect the female end of the serial (RS-232) cable to the serial port on your PC, or connect the USB touchscreen cable to the USB touchscreen connector on the back of your touchmonitor.
- Connect the male end of the cable to the serial touchscreen connector on your touchmonitor, or connect the other end of the USB touchscreen cable to your PC.
- Secure the cable to your touchmonitor and PC by turning the screws on the connector.

STEP 3-Connecting the Speaker Cable

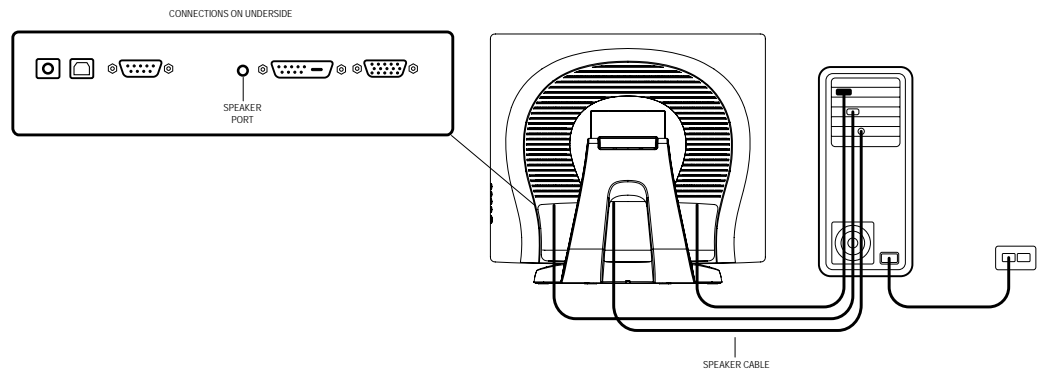

- Connect the light blue end of the speaker cable to the light blue speaker port to the monitor (audio in).
- Connect the lime (light green) end of the speaker cable to the lime speaker port on the computer (audio out).

STEP 4-Connecting the Power Cable

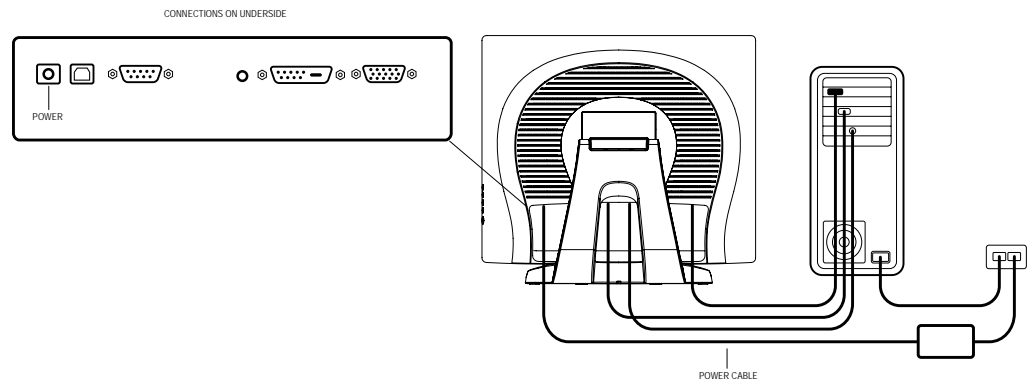

Depending on where you live, you will use either the European or US/Canadian power cable.

- Connect the female end of the power cable to the medical grade power adaptor.
- Connect the brick power cable into the power port on the touchmonitor.
- Route the cable through the cable management channel.

NOTE: To protect your equipment against risk of damage from electrical surges in the power line, plug the touchmonitor's power cord into a surge protector, and then connect the surge protector to a grounded AC electrical outlet.

Optimizing the LCD Display

To ensure the LCD display works well with your computer, configure the display mode of your graphic card to make it less than or equal to 1280 x 1024 resolution, and make sure the timing of the display mode is compatible with the LCD display. Refer to Appendix A for more information about resolution. Compatible video modes for your touchmonitor are listed in Appendix C.

Installing the Touch Driver Software

Elo TouchSystems provides driver software that allows your touchmonitor to work with your computer. Drivers are located on the enclosed CD-ROM for the following operating systems:

- Windows XP
- Windows 2000
- Windows Me
- Windows 98
- Windows 95
- Windows NT 4.0
- CE 2.x, 3.0, 4x
- Windows XP Embedded
- Windows 3.x
- MS DOS
- OS/2

Additional drivers and driver information for other operating systems (including Macintosh and Linux) are available on the Elo TouchSystems web site at www.elotouch.com. Your Elo USB touchmonitor is plug-and-play compliant. Information on the video capabilities of your touchmonitor is sent to your video display adapter when Windows starts. If Windows detects your touchmonitor, follow the instructions on the screen to install a generic plug-and-play monitor. Refer to the appropriate following section for driver installation instructions.

3

OPERATION**About Touchmonitor Adjustments**

Your touchmonitor will unlikely require adjustment. Variations in video output and application may require adjustments to your touchmonitor to optimize the quality of the display.

For best performance, your touchmonitor should be operating in native resolution, that is 1280 x 1024 at 60-75 Hz. Use the display control panel in Windows to choose 1280 x 1024 resolution. Operating in other resolutions will degrade video performance. For further information, please refer to Appendix A. All adjustments you make to the controls are automatically memorized. This feature saves you from having to reset your choices every time you unplug or power your touchmonitor off and on. If there is a power failure your touchmonitor settings will not default to the factory specifications. To restore factory set up, choose it from the OSD. See page 14, Recall Defaults.

Front Panel Controls

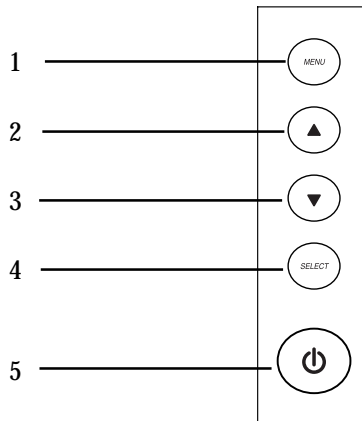

Control	Function
1 Menu/Exit	Display/Exits the OSD menus.
2 ▲	1. Enter contrast of the OSD. 2. Increase value of the adjustment item. 3. Shuffle item clockwise.
3 ▼	1. Enter audio volume adjustment. 2. Decrease value of the adjustment item. 3. Shuffle item counter-clockwise.
4 Select	Select the adjustment items from the OSD menu.
5 Power Switch	Switches the power of the monitor from off to on to off. (Important note: Includes integrated power down delay function, user must depress power button for five (5) seconds when powering off)

Controls and Adjustment

OSD Menu Functions

To Display and Select the OSD Functions:

- 1 Press the Menu key to activate the OSD menu.
- 2 Use ▲ or ▼ to move clockwise or counterclockwise through the menu. Press the select key on the monitor. The parameter will be highlighted when selected.
- 3 To quit the OSD screen at any time during the operation, press the Menu key. If no keys are pressed for a short time period, the OSD automatically disappears.

NOTE: The OSD screen will disappear if no input activities are detected from 45 seconds to 255 seconds, depending on the OSD time setting on the OSD of the monitor. The monitor default is 45 seconds.

OSD Control Options

Control	Description
Contrast	Increases or decreases contrast.
Brightness	Increases or decreases brightness.
V-Position	Moves the screen up or down.
H-Position	Moves the screen left or right.
Recall Defaults	Returns the monitor to its default settings.
Color Balance	Press ▲ or ▼ and “Select” button to select 9300, 6500, 5500, 7500 and USER. Only when selecting USER can you make adjustments to the R/G/B content. Press Select to restore to factory default setting.
Audio Volume	Adjust audio volume of OSD menu.
Sharpness	Adjust Sharpness.
Phase	Increases or decreases the snow noise of the image after auto adjustment is made.
Clock	The dot clock is fine-adjusted after auto adjust.
OSD H-Position	Moves the OSD position horizontally on the screen. When the “SELECT” button and the ▲ button is pressed, the OSD control menu will move to the right side of the screen. Likewise, when the “Select” button and the ▼ button is pressed, the OSD control menu will move to the left side.
OSD V-Position	Moves the OSD position vertically on the screen. When the “SELECT” button and the ▲ button is pressed, the OSD control menu will move to the top side of the screen. Likewise, when the “Select” button and the ▼ button is pressed, the OSD control menu will move to the lower side.
OSD Time	Adjusts the time of OSD icon stays on monitor.
Auto-Adjust	Press Auto to enable this function. The Auto-Adjust will automatically adjust V-Position, H-Position, Clock and Clock-Phase.
OSD Language	Select from English, French, German, Spanish, Japanese, Italian, Chinese and Polish.
Information Description	Indicates the current resolution, H-Frequency and V-Frequency.

Power LED Display & Power Saving

General Power Saving Mode

When the power is on and video is present, this LED lights in green. The LED indicates the different power status with altered LED colors when monitor operates in different modes (see following table).

Mode	Power Consumption	Indicator
On	48w max.	Green
Sleep	7w max.	Orange
Off	4w	NO

Power-Save (No Input)

- The LCD panel background is cut when there is no signal input (AC line power consumption of 7w or less).

Note: If the monitor is not to be used for an extended period of time, it is recommended that the monitor be turned off.

Display Angle

For viewing clarity, you can tilt the LCD forward (up to -5 degrees) or backward (up to 90 degrees).

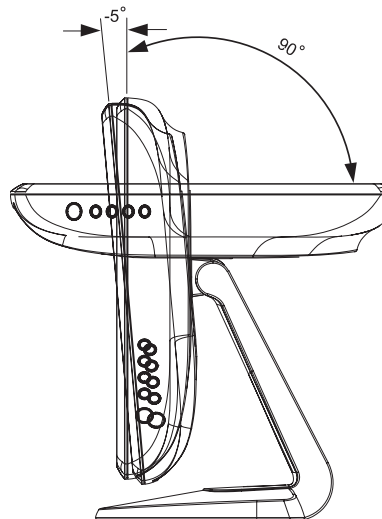

CAUTION

- In order to protect the LCD, be sure to hold the base when adjusting the LCD.
- For models without a touchscreen take care not to touch the screen.

4

TROUBLESHOOTING

If you are experiencing trouble with your touchmonitor, refer to the following table. If the problem persists, please contact your local dealer or our service center. Elo Technical Support numbers are listed on page 31 of this manual.

Solutions to Common Problems

Problem	Suggestion(s)
The monitor does not respond	Check that the monitor's Power Switch is on. You turn on the system. Turn off the power and check the monitor's power cord and signal cable for proper connection.
Characters on the screen are dim	Refer to the Controls and Adjustments section to adjust the brightness.
The screen is blank	During operation, the monitor screen may automatically turn off as a result of the Power Saving feature. Press any key to see if the screen reappears.
OSD or power buttons don't work	Refer to the Controls and Adjustments section to adjust the brightness.
"Out of Range" display	Check to see that they are not locked out. See page 10. Check to see if the resolution or vertical frequency of your computer is higher than that of the LCD display. Reconfigure the resolution of your computer to make it less than or equal to 1280 x 1024. 1280 x 1024 is optimal. See Appendix A for more information on resolution.
Touch doesn't work	Make sure cable is securely attached at both ends.
Power will not shut off immediately	Be sure to depress power button for five(5) seconds when powering off. Unit includes integrated power down delay function.

A

NATIVE RESOLUTION

The native resolution of a monitor is the resolution level at which the LCD panel is designed to perform best. 1928L native resolution is 1280 x 1024. In almost all cases, screen images look best when viewed at their native resolution. You can lower the resolution setting of a monitor but not increase it.

Input Video	19.0" LCD
640 x 480(VGA)	Transforms input format to 1280 x 1024
800 x 600 (SVGA)	Transforms input format to 1280 x 1024
1024 x 768(XGA)	Transforms input format to 1280 x 1024
1280 x 1024(SXGA)	Display in Native Resolution

The native resolution of an LCD is the actual number of pixels horizontally in the LCD by the number of pixels vertically in the LCD. LCD resolution is usually represented by the following symbols:

VGA	640 x 480
SVGA	800 x 600
XGA	1024 x 768
SVGA	1280 x 1024

As an example, a SVGA resolution LCD panel has 800 pixels horizontally by 600 pixels vertically. Input video is also represented by the same terms. XGA input video has a format of 1280 pixels horizontally by 1024 pixels vertically. When the input pixels contained in the video input format match the native resolution of the panel, there is a one to one correspondence of mapping of input video pixels to LCD pixels. As an example, the pixel in column 45 and row 26 of the input video is in column 45 and row 26 of the LCD. For the case when the input video is at a lower or higher resolution than the native resolution of the LCD, the direct correspondence between the video pixels and the LCD pixels is lost. The LCD controller can compute the correspondence between video pixels and LCD pixels using algorithms contained on its controller. The accuracy of the algorithms determines the fidelity of conversion of video pixels to LCD pixels. Poor fidelity conversion can result in artifacts in the LCD displayed image such as varying width characters.

B

TOUCHMONITOR SAFETY

This manual contains information that is important for the proper setup and maintenance of your touchmonitor. Before setting up and powering on your new touchmonitor, read through this manual, especially Chapter 2 (Installation), and Chapter 3 (Operation).

1. To reduce the risk of electric shock, follow all safety notices and never open the touchmonitor case.
2. Turn off the product before cleaning
3. Your new touchmonitor is equipped with a 3-wire, Hospital Grade grounding power cord. The power cord plug will only fit into a grounded outlet. Do not attempt to fit the plug into an outlet that has not been configured for this purpose. Do not use a damaged power cord. Use only the power cord that comes with your Elo TouchSystems Touchmonitor. Use of an unauthorized power cord may invalidate your warranty.
4. The slots located on the sides and top of the touchmonitor case are for ventilation. Do not block or insert anything inside the ventilation slots.
5. It is important that your touchmonitor remains dry. Do not pour liquid into or onto your touchmonitor. If your touchmonitor becomes wet do not attempt to repair it yourself.

Care and Handling of Your Touchmonitor

The following tips will help keep your Elo touchmonitor functioning at the optimal level.

- To avoid risk of electric shock, do not disassemble the external power adaptor or display unit cabinet. The unit is not user serviceable. Remember to unplug the display unit from the power outlet before cleaning.
- Do not use alcohol (methyl, ethyl or isopropyl) or any strong dissolvent. Do not use thinner or benzene, abrasive cleaners or compressed air.
- To clean the display unit cabinet, use a cloth lightly dampened with a mild detergent.
- Avoid getting liquids inside your touchmonitor. If liquid does get inside, have a qualified service technician check it before you power it on again.
- Do not wipe the screen with a cloth or sponge that could scratch the surface.
- To clean the touchscreen, use window or glass cleaner. Put the cleaner on the rag and wipe the touchscreen. Never apply the cleaner directly on the touchscreen .



C

TECHNICAL SPECIFICATIONS

Display Modes

Your Elo touchmonitor is compatible with the following standard video modes:

Item	Resolution	Type	H.Scan(KHz)	V. Scan(Hz)	Polarity
1	640 x 350	VGA	31.47	70	
2	720 x 400	VGA	31.47	70	
3	640 x 480	VGA	31.47	60	
4	640 x 480	MAC 66	35	66	-/-
5	640 x 480	VESA 72	37.86	72	-/-
6	640 x 480	VESA 75	37.5	75	-/-
7	800 x 600	VESA 56	35.16	56	+/+
8	800 x 600	VESA 60	37.88	60	+/+
9	800 x 600	VESA 75	46.88	75	+/+
10	800 x 600	VESA 72	48.08	72	+/+
11	832 x 624	MAC 75	49.72	75	-/-
12	1024 x 768	VESA 60	48.36	60	-/-
13	1024 x 768	SUN 65	52.45	65	-/-
14	1024 x 768	VESA 70	56.48	70	-/-
15	1024 x 768	VESA 75	60.02	75	+/+
16	1280 x 1024	SXGA	64	60	+/+
17	1280 x 1024	SXGA	80	75	+/+
18	1152 x 864	SXGA	67.5	75	+/+
19	1280 x 960	SXGA	60	60	+/+

Touchmonitor Specifications

Parameter	Value
LCD Display	19.0" TFT Active Matrix Panel
Pixel Pitch	0.294(H) x 0.294(V) mm
Display Mode	VGA 640 x 350 (70 Hz) VGA 720 x 400 (70 Hz) VGA 640 x 480 (60 / 72 / 75 Hz) SVGA 800 x 600 (56 / 60 / 72 / 75 Hz) SXGA 1280 x 1024(60,70,75 Hz)
Native	SXGA 1280 x 1024
Contrast Ratio	1300 : 1 (typical)
Brightness	300 cd/m ² with AT 246 cd/m ² , IT 276 cd/m ² , IR 276 cd/m ²
LCD	300 cd/m ² (typical)
AccuTouch	246 cd/m ² (typical)
IntelliTouch	276 cd/m ² (typical)
Response Time	Tr = 15 msec, Tf = 5 msec typical ; 12 ms gray to gray
Display Color	16.7 million color, 6 bit with dithering
Viewing Angle	(L/R)= -89°/+89° (typical), (U/D) -89°/+89° (typical)
Input Signal	VGA Analog Video R.G.B. Analog 0.7V peak to peak Sync TTL Positive or Negative, Composite Sync, Sync on green DVI Video Digital TMDS Input
Signal Connector	15 Pin D-Sub, DVI-D
Front Control	Power ON / OFF, Menu, Select OSD Contrast, Brightness, H/V- Position, Recall default, Color Temperature, Sharpness, Phase, Clock OSD H/V position, OSD Time, Auto Adjust, OSD Language, Input Select
Plug & Play	DDC1 / 2B
Touch Panel	AccuTouch , IntelliTouch
Power	
External Power Supply*	AC 100-240V, 50/60 Hz/1.0A
Monitor	DC 12V, 4A
Environmental	
Temp. Operating	0°C to 40°C
Storage/Transportation	-20°C to +60°C
Humidity (non-condensing)	
Operating	30% to 70%
Storage/Transportation	10% to 90%
Altitude Operating	1060hpa
Storage/Transportation	0 to 40,000ft (12,192m) Equivalent to 1013-303 hP.A (14.7 to 4.4 psia)
Dimensions (H x W x D)	429 x 390 x 212 mm
Weight (Net)	8.4kg.
Certifications	UL, C-UL, FCC, CE, VCCI, MPRII, C-TICK

* **FOR CONTINUED SAFETY - Use only with Hitron Model HES49-12040 adaptor.**

Power Supply Cord Selection

North America

Power Supply Cord ;V Detachable, UL Listed, Type SJT 3 conductor, 18 AWG, configured load fittings terminating in molded on parallel blade. Grounding type hospital grade attachment plug, rated at a minimum of 3 amperes.

Basic Cord Type	Equivalent Types
SP-2	SPE-2, SPT-2
SP-3	SPE-3, SPT-3
SV	SVE, SVO, SVOO, SVT, SVTO, SVTOO
SJ	SJE, SJO, SJOO, SJT, SJTO, SJTOO
S	SE, SO, SOO, ST, STO, STOO

Grounding reliability can only be achieved when the EQUIPMENT is connected to an equivalent receptacle marked "Hospital Only" or "Hospital Grade".

Cord selection for other than North America

For 100 V ac or 220/230/240 V ac operation, the unit is provided with IEC 320 flexible power cords properly configured for the intended country other than North America. The NOMINAL cross-sectional area (mm² Cu) must be 0,75. For assistance in selecting the proper power cord contact the Elo distributor in your area or contact Elo (see Appendix D, page 23)

<i>Country</i>	<i>Cert Agency</i>	<i>Mark</i>	<i>Country</i>	<i>Cert Agency</i>	<i>Mark</i>
Argentina	IRAM		Ireland	NSAI	
Australia	SAA		Italy	IMQ	
Austria	OVE		Japan	MITI	
Belgium	CEBEC		Netherlands	KEMA	
Canada	CSA		Japan	MITI	
China	CCEE		Norway	NEMKO	
Denmark	DEMKO		Sweden	SEMKO	
Finland	FEI		Switzerland	SEV	
France	UTE		United Kingdom	ASTA	
Germany	VDE			BSI	

HAR FLEXIBLE CORD

Approval Organization	Printed or Embossed Harmonization Marking be Located On Jacket or Insulation of Internal Wiring)		Alternative Marking (May Utilizing Black-Red Yellow Thread (Length of color Section, mm)		
Comite Electrotechnique Belge (CEBEC)	CEBEC	<HAR>	10	30	10
Verband Deutscher Elektrotechniker (VDE) e.V. Prufstelle	<VDE>	<HAR>	30	10	10
Union technique de l'Electricite (UTE)	USE	<HAR>	30	10	30
Instituto Italiano del Marchio di Qualita (IMQ)	IEMMEQU	<HAR>	10	30	50
British Approvals Service for Electric Cables (BASEC)	BASEC	<HAR>	10	10	30
N> V. KEMA	KEMA-KEUR	<HAR>	10	30	30
SEMKO AB Svenska Elektriska Materielkontrollanstalter	SEMKO	<HAR>	10	10	50
Österreichischer Verband für Elektrotechnik (ÖVE)	<ÖVE>	<HAR>	30	10	50
Danmarks Elektriske Materialkontroll	<DEMKO>	<HAR>	30	10	30
National Standards Authority of Ireland (NSAI)	<NSAI>	<HAR>	30	30	50
Norges Elektriske Materielkontroll (NEMKO)	NEMKO	<HAR>	10	10	70
Asociacion Electrotecnica Y Electronica Espanola (AEE)	<UNED>	<HAR>	30	10	70
Hellenic Organization for Standardization (ELOT)	ELOT	<HAR>	30	30	70
Instituto Portages da Qualidade (IPQ)	np	<HAR>	10	10	90
Schweizerischer Elektro Technischer Verein (SEV)	SEV	<HAR>	10	30	90
Elektriska Inspektoratet	SETI	<HAR>	10	30	90

AccuTouch (resistive) Touchscreen Specifications

Mechanical

Positional Accuracy	Standard deviation of error is less than 0.080 in. (2.03 mm). Equates to less than $\pm 1\%$.
Touchpoint Density	More than 100,000 touchpoints/in ² (15,500 touchpoints/cm ²)
Touch Activation Force	Typical less than 3 ounces(85 grams)
Surface Durability Expected Life Performance	Surface durability is that of glass, Mohs' hardness rating of 7. No known wear-out mechanism, as there are no layers, coatings, or moving parts. IntelliTouch technology has been operationally tested to more than 50 million touches in one location without failure, using a stylus similar to a finger.
Sealing	Unit is sealed to protect against splashed liquids, dirt, and dust.

Optical

Light Transmission (per ASTM D1003)	90%
Visual Resolution	All measurements made using USAF 1951 Resolution Chart, under 30X magnification, with test unit located approximately 1.5 in (38 mm) from surface of resolution chart. Clear surface: Excellent, with no noticeable degradation. Antiglare surface: 6:1 minimum.
Gloss (per ASTM D2457 using a 60-degree gloss meter)	Antiglare surface: Curved: 60 ± 20 gloss units or 75 ± 15 gloss units.
Environmental Chemical Resistance	The active area of the touchscreen is resistant to all chemicals that do not affect glass, such as: Acetone, Toluene, Methyl ethyl ketone, Isopropyl alcohol, Methyl alcohol, Ethyl acetate, Ammonia-based glass cleaners, Gasoline, Kerosene, Vinegar
Electrostatic Protection (per EN 61 000-4-2, 1995)	Meets Level 4 (15 kV air/8 kV contact discharges).

IntelliTouch Touchmonitor Specifications

Mechanical

Positional Accuracy	Standard deviation of error is less than 0.080 in. (2.03 mm). Equates to less than ±1%.
Touchpoint Density	More than 100,000 touchpoints/in ² (15,500 touchpoints/cm ²).
Touch Activation Force	Typically less than 3 ounces (85 grams).
Surface Durability	Surface durability is that of glass, Mohs' hardness rating of 7.
Expected Life Performance	No known wear-out mechanism, as there are no layers, coatings, or moving parts. IntelliTouch technology has been operationally tested to more than 50 million touches in one location without failure, using a stylus similar to a finger.
Sealing	Unit is sealed to protect against splashed liquids, dirt, and dust.
Optical	
Light Transmission (per ASTM D1003)	IntelliTouch 92%, AccuTouch 82%.
Visual Resolution	All measurements made using USAF 1951 Resolution Chart, under 30X magnification, with test unit located approximately 1.5 in (38 mm) from surface of resolution chart. Clear surface: Excellent, with no noticeable degradation. Antiglare surface: 6:1 minimum.
Gloss (per ASTM D2457 using a 60-degree gloss meter)	Antiglare surface: Curved: 60 ±20 gloss units or 75 ± 15 gloss units.

D

Contact Elo

Elo TouchSystems
301 Constifution Drive
Menlo Park, CA 94025
1-800-ELO-TOUCH
(1-800-356-8682)
www.eloinfo.elotouch.com

REGULATORY INFORMATION

I. Electrical Safety Information:

A) Compliance is required with respect to the voltage, frequency, and current requirements indicated on the manufacturer's label. Connection to a different power source than those specified herein will likely result in improper operation, damage to the equipment or pose a fire hazard if the limitations are not followed.

B) There are no operator serviceable parts inside this equipment. There are hazardous voltages generated by this equipment which constitute a safety hazard. Service should be provided only by a qualified service technician.

C) This equipment is provided with a detachable power cord which has an integral safety ground wire intended for connection to a grounded safety outlet.

- 1) Do not substitute the cord with other than the provided approved type. Under no circumstances use an adapter plug to connect to a 2-wire outlet as this will defeat the continuity of the grounding wire.
- 2) The equipment requires the use of the ground wire as a part of the safety certification, modification or misuse can provide a shock hazard that can result in serious injury or death.
- 3) Contact a qualified electrician or the manufacturer if there are questions about the installation prior to connecting the equipment to mains power.

II. Emissions and Immunity Information

A) Notice to Users in the United States: This equipment has been tested and found to comply with the limits for a Class B digital device, pursuant to Part 15 of FCC Rules. These limits are designed to provide reasonable protection against harmful interference in a residential installation. This equipment generates, uses, and can radiate radio frequency energy, and if not installed and used in accordance with the instructions, may cause harmful interference to radio communications.

B) Notice to Users in Canada: This equipment complies with the Class B limits for radio noise emissions from digital apparatus as established by the Radio Interference Regulations of Industrie Canada.

C) Notice to Users in the European Union: Use only the provided power cords and interconnecting cabling provided with the equipment. Substitution of provided cords and cabling may compromise electrical safety or CE Mark Certification for emissions or immunity as required by the following standards:

This Medical Electrical Equipment is required to have a CE Mark on the manufacturer's label which means that the equipment has been tested to the following Directives and Standards: This equipment has been tested to the requirements for the CE Mark as required by medical device Directive (MDD) 93/42/EEC indicated in European Standard EN60601-1 and EN60601-1-2 (including EN55011 Class B).

D) General Information to all Users: This equipment generates, uses and can radiate radio frequency energy. If not installed and used according to this manual the equipment may cause interference with radio and television communications. There is, however, no guarantee that interference will not occur in any particular installation due to site-specific factors.

- 1) In order to meet emission and immunity requirements, the user must observe the following:
 - a) Use only the provided I/O cables to connect this digital device with any computer.
 - b) To ensure compliance, use only the provided manufacturer's approved line cord.
 - c) The user is cautioned that changes or modifications to the equipment not expressly approved by the party responsible for compliance could void the user's authority to operate the equipment.
- 2) If this equipment appears to cause interference with radio or television reception, or any other device:
 - a) Verify as an emission source by turning the equipment off and on.
 - b) If you determine that this equipment is causing the interference, try to correct the interference by using one or more of the following measures:
 - i) Move the digital device away from the affected receiver.
 - ii) Reposition (turn) the digital device with respect to the affected receiver.
 - iii) Reorient the affected receiver's antenna.
 - iv) Plug the digital device into a different AC outlet so the digital device and the receiver are on different branch circuits.
 - v) Disconnect and remove any I/O cables that the digital device does not use. (Unterminated I/O cables are a potential source of high RF emission levels.)
 - vi) Plug the digital device into only a grounded outlet receptacle. Do not use AC adapter plugs. (Removing or cutting the line cord ground may increase RF emission levels and may also present a lethal shock hazard to the user.)

If you need additional help, consult your dealer, manufacturer, or an experienced radio or television technician.

WARRANTY

Except as otherwise stated herein or in an order acknowledgment delivered to Buyer, Seller warrants to Buyer that the Product shall be free of defects in materials and workmanship. The warranty for the touchmonitors and components of the product is 3 years.

Seller makes no warranty regarding the model life of components. Seller's suppliers may at any time and from time to time make changes in the components delivered as Products or components.

Buyer shall notify Seller in writing promptly (and in no case later than thirty (30) days after discovery) of the failure of any Product to conform to the warranty set forth above; shall describe in commercially reasonable detail in such notice the symptoms associated with such failure; and shall provide to Seller the opportunity to inspect such Products as installed, if possible. The notice must be received by Seller during the Warranty Period for such product, unless otherwise directed in writing by the Seller. Within thirty (30) days after submitting such notice, Buyer shall package the allegedly defective Product in its original shipping carton(s) or a functional equivalent and shall ship to Seller at Buyer's expense and risk.

Within a reasonable time after receipt of the allegedly defective Product and verification by Seller that the Product fails to meet the warranty set forth above, Seller shall correct such failure by, at Seller's options, either (i) modifying or repairing the Product or (ii) replacing the Product. Such modification, repair, or replacement and the return shipment of the Product with minimum insurance to Buyer shall be at Seller's expense. Buyer shall bear the risk of loss or damage in transit, and may insure the Product. Buyer shall reimburse Seller for transportation cost incurred for Product returned but not found by Seller to be defective. Modification or repair, of Products may, at Seller's option, take place either at Seller's facilities or at Buyer's premises. If Seller is unable to modify, repair, or replace a Product to conform to the warranty set forth above, then Seller shall, at Seller's option, either refund to Buyer or credit to Buyer's account the purchase price of the Product less depreciation calculated on a straight-line basis over Seller's stated Warranty Period.

THESE REMEDIES SHALL BE THE BUYER'S EXCLUSIVE REMEDIES FOR BREACH OF WARRANTY. EXCEPT FOR THE EXPRESS WARRANTY SET FORTH ABOVE, SELLER GRANTS NO OTHER WARRANTIES, EXPRESS OR IMPLIED BY STATUTE OR OTHERWISE, REGARDING THE PRODUCTS, THEIR FITNESS FOR ANY PURPOSE, THEIR QUALITY, THEIR MERCHANTABILITY, THEIR NONINFRINGEMENT, OR OTHERWISE. NO EMPLOYEE OF SELLER OR ANY OTHER PARTY IS AUTHORIZED TO MAKE ANY WARRANTY FOR THE GOODS OTHER THAN THE WARRANTY SET FORTH HEREIN. SELLER'S LIABILITY UNDER THE WARRANTY SHALL BE LIMITED TO A REFUND OF THE PURCHASE PRICE OF THE PRODUCT. IN NO EVENT SHALL SELLER BE LIABLE FOR THE COST OF PROCUREMENT OR INSTALLATION OF SUBSTITUTE GOODS BY BUYER OR FOR ANY SPECIAL, CONSEQUENTIAL, INDIRECT, OR INCIDENTAL DAMAGES.

Buyer assumes the risk and agrees to indemnify Seller against and hold Seller harmless from all liability relating to (i) assessing the suitability for Buyer's intended use of the Products and of any system design or drawing and (ii) determining the compliance of Buyer's use of the Products with applicable laws, regulations, codes, and standards. Buyer retains and accepts full responsibility for all warranty and other claims relating to or arising from Buyer's products, which include or incorporate Products or components manufactured or supplied by Seller. Buyer is solely responsible for any and all representations and warranties regarding the Products made or authorized by Buyer. Buyer will indemnify Seller and hold Seller harmless from any liability, claims, loss, cost, or expenses (including reasonable attorney's fees) attributable to Buyer's products or representations or warranties concerning same.

INDEX

Numerics

ET1928L-XXWA-1-G

A

About touchmonitor Adjustments, 11
AccuTouch(resistive)Touchscreen Specifications, 28
Audio Volume, 14
Auto-Adjust, 14

B

Back Unit, 4
Base Bottom View, 5
Brightness, 14

C

Care and Handling of your Touchmonitor, 22
Caution-Life Support, v
Classification, vi
Clock, 14
Color Balance, 14
Connecting the Video Cable, 6
Connecting the Serial and USB Touchscreen Cable, 7
Connecting the Speaker Cable, 8
Connecting the Power Cable, 9
Contrast, 14
Control and Adjustment, 13
Cord selection for other than North America, 26

D

Display Angle, 15
Display Modes, 23

E

Electrical Safety Information, 33
Electrostatic Protection, 28
Emissions and Immunity Information, 33
Environmental Chemical Resistance, 28
Expected Life Performance, 28, 29
External Medical Grade Power Supply, 2

F

Front Panel Controls, 12

G

General Power Saving Mode, 15
Gloss, 28, 29

H

H-Position, 14

I

Information Description, 14
Installation and setup, 2
Installing the Touch Driver Software, 10
Intellitouch Touchmonitor Specifications, 29
Introduction, 1

K

Kensington™ Lock, 2

L

LCD Display Performance Features, 2
Light Transmission, 28

M

Main Unit, 4

N

Native Resolution, 19

O

Operation, 11
Optical Light Transmission, 29
Optimizing the LCD Display, 10
OSD Control Options, 14
OSD Menu Functions, 13
OSD H-Position, 14
OSD Language, 14
OSD or power buttons doesn't work, 17
OSD V-Position, 14
OSD Time, 14
Out of range display, 14

P

Performance, 29
Phase, 14
Positional Accuracy, 28, 29
Power LED Display & Power Saving, 15
Power-Save, 15
Power will not shut off immediately, 17
Power Supply Cord Selection, 25
Product Overview, 4

R

Rear View, 10
Recall Defaults, 14
Regulatory Information, 33

S

Sealing, 28, 29
Sharpness, 14
Side View, 4
Solutions to Common Problems, 17
Surface Durability, 28, 29
SVGA, 19

T

Technical Specifications, 23
Touch Activation Force, 28, 29
Touch Interface Connection, 6
Touch doesn't work, 17
Touchmonitor Safety, 21
Touchmonitor Specifications, 24
Touchpoint Density, 28, 29
Troubleshooting, 17

U

Unpacking Your Touchmonitor, 3

V

VGA, 19
Visual Resolution, 28, 29
V-Position, 14

W

Warranty, 35
Warnings and Cautions, iv

X

XGA, 19

Check out Elo's Web site!

www.elotouch.com

Get the latest...

• **Product information**

• **Specifications**

• **News on upcoming events**

• **Press release**

• **Software drivers**

Getting in Touch with Elo

To find out more about Elo's extensive range of touch solutions, visit our Web site at www.elotouch.com or simply call the office nearest you:

USA & Headquarters

Elo TouchSystems
301 Constitution Drive
Menlo Park, CA 94025
USA

(800) ELO-TOUCH (800-356-8682)
Tel 650-361-4700
Fax 650-361-4747
eloinfo@elotouch.com

Germany

Elo TouchSystems GmbH & Co. KG
Haidgraben 6
D-85521 Ottobrunn
Germany

Tel +49(89)60822-0
Fax +49(89)60822-150
elosales@elotouch.com

Belgium

Elo TouchSystems
Diestsesteenweg 692
B-3010 Kessel-Lo
Belgium

Tel +32(16)35-2100
Fax +32(16)35-2101
elosales@elotouch.com

Japan

Touch Panel Systems K.K
Sun Homada Bldg. 2F
1-19-20 Shin-Yokohama
Kanagawa 222-0033
Japan

Tel +81(45)478-2161
Fax +81(45)478-2180
www.tps.co.jp

tyco
Electronics

