

Dell™ Dimension™ 5100C

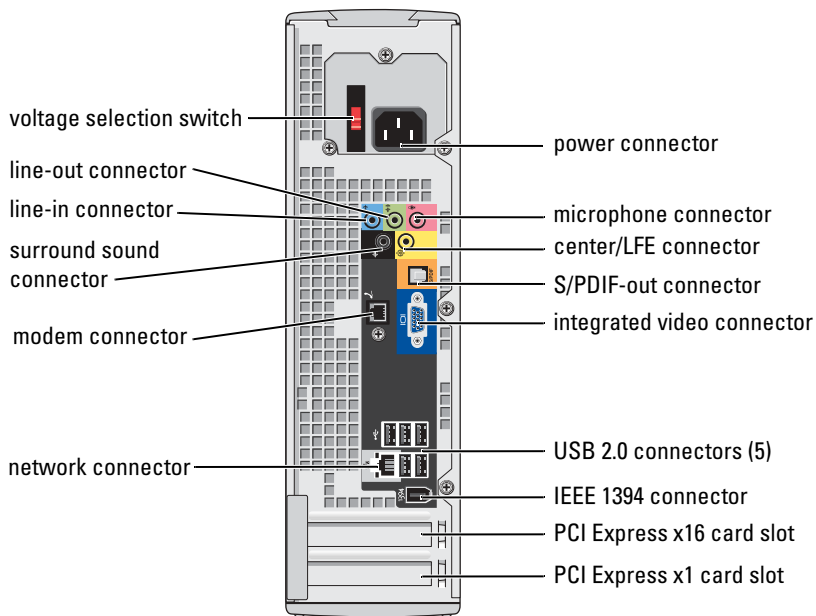
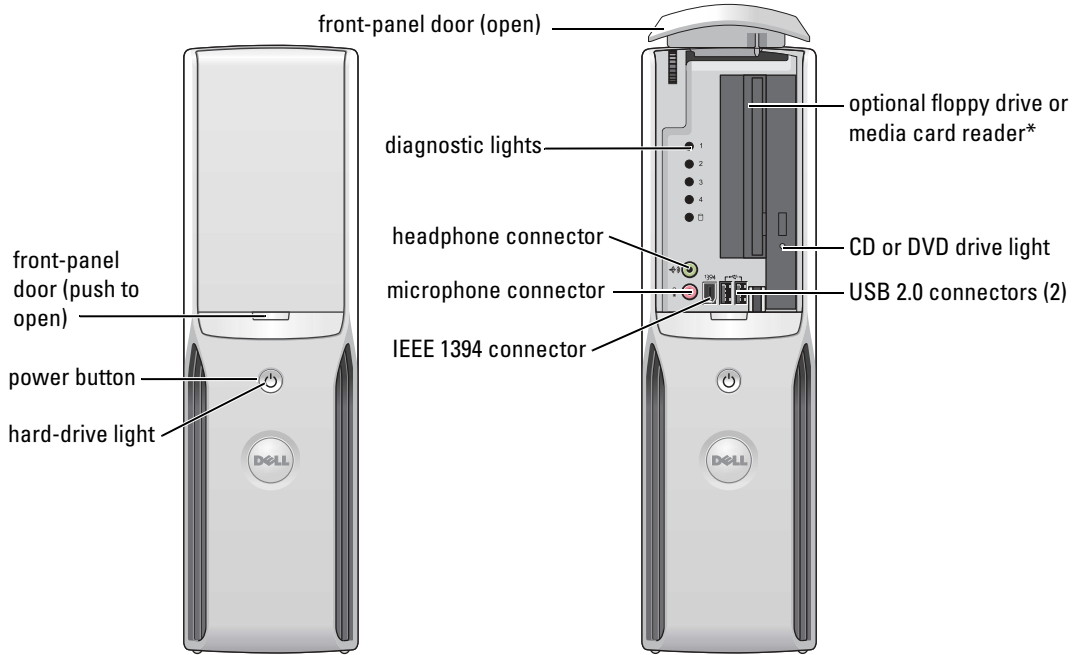

* Not present on certain computers.

Model DHP

Notes, Notices, and Cautions



NOTE: A NOTE indicates important information that helps you make better use of your computer.



NOTICE: A NOTICE indicates either potential damage to hardware or loss of data and tells you how to avoid the problem.



CAUTION: A CAUTION indicates a potential for property damage, personal injury, or death.

If you purchased a Dell™ n Series computer, any references in this document to Microsoft® Windows® operating systems are not applicable.

Information in this document is subject to change without notice.

© 2005 Dell Inc. All rights reserved.

Reproduction in any manner whatsoever without the written permission of Dell Inc. is strictly forbidden.

Trademarks used in this text: *Dell*, the *DELL* logo, *Inspiron*, *Dell Precision*, *Dimension*, *OptiPlex*, *Latitude*, *PowerEdge*, *PowerVault*, *PowerApp*, *DellNet*, and *PowerConnect* are trademarks of Dell Inc.; *Intel*, *Pentium*, and *Celeron* are registered trademarks of Intel Corporation; *Microsoft*, *Windows*, and *Outlook* are registered trademarks of Microsoft Corporation.

Other trademarks and trade names may be used in this document to refer to either the entities claiming the marks and names or their products. Dell Inc. disclaims any proprietary interest in trademarks and trade names other than its own.

Model DHP

February 2005

P/N T8243

Rev. A00

Contents

Finding Information	9
1 Setting Up and Using Your Computer	
Setting Up a Printer	13
Printer Cable	13
Connecting a USB Printer.	14
Using a Media Card Reader (Optional)	14
Connecting a TV (Optional)	15
Changing the Display Settings	16
Setting Up a Home and Office Network	16
Connecting to a Network Adapter	16
Network Setup Wizard	17
Connecting to the Internet	17
Setting Up Your Internet Connection	17
Playing a CD or DVD	18
Adjusting the Volume	21
Adjusting the Picture	21
Copying CDs and DVDs.	21
How to Copy a CD or DVD.	21
Using Blank CD-Rs, CD-RWs, DVD+R, and DVD+RW.	22
Helpful Tips	22
Power Management	23
Standby Mode	23
Hibernate Mode.	24
Power Options Properties	24
Hyper-Threading	25

2 Solving Problems

Troubleshooting Tips	27
Battery Problems	27
Drive Problems	27
CD and DVD drive problems	28
Hard drive problems	29
E-Mail, Modem, and Internet Problems	29
Error Messages	30
Media Card Reader Problems	31
IEEE 1394 Device Problems	31
Keyboard Problems	32
Lockups and Software Problems	32
The computer does not start up	32
The computer stops responding	33
A program stops responding	33
A program crashes repeatedly	33
A program is designed for an earlier Windows operating system	33
A solid blue screen appears	33
Other software problems	34
Memory Problems	34
Mouse Problems	35
Network Problems	36
Power Problems	36
Printer Problems	37
Scanner Problems	38
Sound and Speaker Problems	39
No sound from speakers	39
No sound from headphones	40
Video and Monitor Problems	40
If the screen is blank	40
If the screen is difficult to read	41

3 Troubleshooting Tools

Diagnostic Lights	43
Dell Diagnostics	46
When to Use the Dell Diagnostics	46
Dell Diagnostics Main Menu	46
Drivers	47
What Is a Driver?	47
Reinstalling Drivers	48
Resolving Software and Hardware Incompatibilities	49
Restoring Your Operating System	49
Using Microsoft Windows XP System Restore	49

4 Removing and Installing Parts

Before You Begin	53
Recommended Tools	53
Turning Off Your Computer	53
Before Working Inside Your Computer	53
Front and Back View of the Computer	55
Front View	55
Back View	57
Removing the Computer Cover	59
Inside View of Your Computer	61
System Board Components	62
Memory	63
DDR2 Memory Overview	63
Addressing Memory With 4-GB Configurations	64
Installing Memory	64
Removing Memory	66
Cards	66
PCI Express Cards	67

Drives	71
Connecting Drive Cables	72
Drive Interface Connectors	72
Power Cable Connector	72
Connecting and Disconnecting Drive Cables	73
Hard Drive	73
Removing a Hard Drive	73
Installing a Hard Drive	75
CD/DVD Drive	76
Removing a CD/DVD Drive	76
Installing a CD/DVD Drive	78
Media Card Reader	79
Removing a Media Card Reader	80
Installing a Media Card Reader	81
Floppy Drive (Optional)	83
Removing a Floppy Drive	83
Installing a Floppy Drive	85
Modem	87
Replacing the External Modem Connector	88
Battery	89
Replacing the Battery	90
Replacing the Computer Cover	91

5 Appendix

Specifications	93
System Setup	97
Overview	97
Entering System Setup	98
System Setup Options	99
Boot Sequence	102
Clearing Forgotten Passwords	103
Clearing CMOS Settings	104

Cleaning Your Computer	105
Computer, Keyboard, and Monitor	105
Mouse.	105
CDs and DVDs.	106
Dell Technical Support Policy (U.S. Only)	106
Definition of "Dell-Installed" Software and Peripherals	106
Definition of "Third-Party" Software and Peripherals.	107
FCC Notices (U.S. Only)	107
Class A	107
Class B	107
FCC Identification Information	108
Contacting Dell.	108
 Index	 125

Finding Information

 **NOTE:** Some features may not be available for your computer or in certain countries.

 **NOTE:** Additional information may ship with your computer.

What Are You Looking For?	Find it Here
<ul style="list-style-type: none">• Warranty information• Terms and Conditions (U.S. only)• Safety instructions• Regulatory information• Ergonomics information• End User License Agreement	<p>Dell™ Product Information Guide</p> 
<ul style="list-style-type: none">• How to set up my computer	<p>Setup Diagram</p>



What Are You Looking For?

- Service Tag and Express Service Code
- Microsoft Windows License Label

Find it Here
Service Tag and Microsoft Windows License

These labels are located on your computer.

- Use the Service Tag to identify your computer when you use support.dell.com or contact technical support.



- Enter the Express Service Code to direct your call when contacting technical support.

-
- Solutions — Troubleshooting hints and tips, articles from technicians, online courses, frequently asked questions
 - Community — Online discussion with other Dell customers
 - Upgrades — Upgrade information for components, such as memory, the hard drive, and the operating system
 - Customer Care — Contact information, service call and order status, warranty, and repair information
 - Service and support — Service call status and support history, service contract, online discussions with technical support
 - Reference — Computer documentation, details on my computer configuration, product specifications, and white papers
 - Downloads — Certified drivers, patches, and software updates
- 1 Desktop System Software (DSS)**— If you reinstall the operating system for your computer, you should also reinstall the DSS utility. DSS provides critical updates for your operating system and support for Dell™ 3.5-inch USB floppy drives, Intel® Pentium® M processors, optical drives, and USB devices. DSS is necessary for correct operation of your Dell computer. The software automatically detects your computer and operating system and installs the updates appropriate for your configuration.

Dell Support Website — support.dell.com

NOTE: Select your region to view the appropriate support site.

- Corporate, government, and education customers can also use the customized Dell Premier Support website at premier.support.dell.com. The website may not be available in all regions.

What Are You Looking For?

- How to use Windows XP
- Documentation for my computer
- Documentation for devices (such as a modem)

Find it Here**Windows Help and Support Center**

- 1** Click the **Start** button and click **Help and Support**.
 - 2** Type a word or phrase that describes your problem and click the arrow icon.
 - 3** Click the topic that describes your problem.
 - 4** Follow the instructions on the screen.
-

Setting Up and Using Your Computer

Setting Up a Printer

 **NOTICE:** Complete the operating system setup before you connect a printer to the computer.

See the documentation that came with the printer for setup information, including how to:

- Obtain and install updated drivers.
- Connect the printer to the computer.
- Load paper and install the toner or ink cartridge.
- Contact the printer manufacturer for technical assistance.

Printer Cable

Your printer connects to your computer with a USB cable. Your printer may not come with a printer cable, so if you purchase a cable separately, ensure that it is compatible with your printer. If you purchased a printer cable at the same time you purchased your computer, the cable may arrive in the computer box.

Connecting a USB Printer

 **NOTE:** You can connect USB devices while the computer is turned on.

- 1 Complete the operating system setup, if you have not already done so.
- 2 Install the printer driver if necessary. See the documentation that came with your printer.
- 3 Attach the USB printer cable to the USB connectors on the computer and the printer. The USB connectors fit only one way.

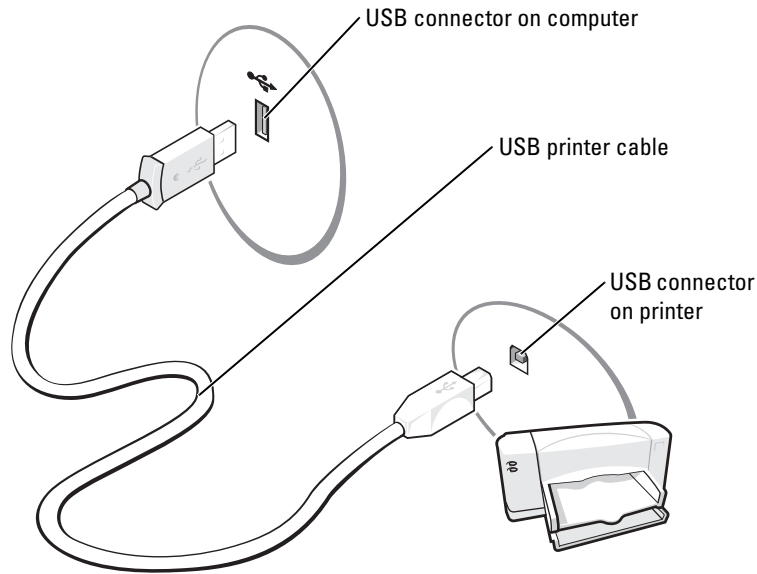

Using a Media Card Reader (Optional)

Use the media card reader to transfer data directly to your computer.

The media card reader supports the following memory types:

- xD-Picture Card
- SmartMedia (SMC)
- CompactFlash Type I and II (CF I/II)
- MicroDrive Card
- SecureDigital Card (SD)
- MultiMediaCard (MMC)
- Memory Stick (MS/MS Pro)

For information on installing a Media Card Reader, see "Installing a Media Card Reader" on page 81.

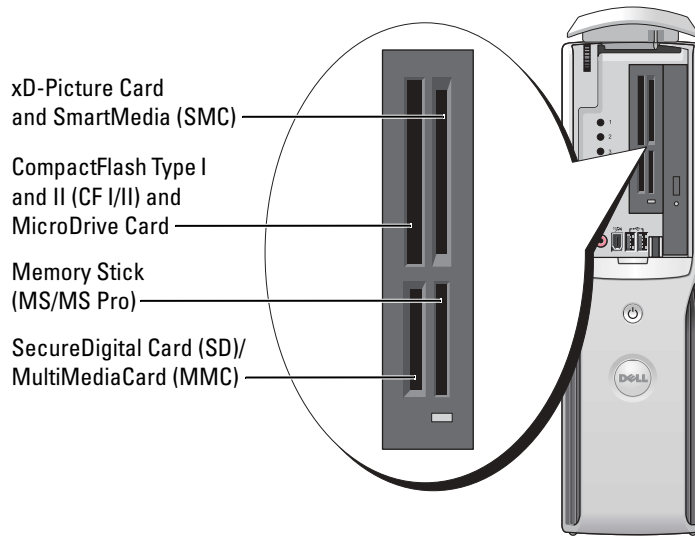

To use the media card reader:

- 1 Check the media or card to determine the proper orientation for insertion.
- 2 Slide the media or card into the appropriate slot until it is completely seated in the connector.

If you encounter resistance, do not force the media or card. Check the card orientation and try again.

Connecting a TV (Optional)

NOTE: To connect a TV to your computer, you must have a video card that has TV-out functionality, and purchase an S-video cable, which is available at most consumer electronics stores. An S-video cable is not included with your computer.

- 1 Follow the procedures in "Before You Begin" on page 53.
- 2 Connect one end of the S-video cable to the TV-OUT connector on the back of the computer.
- 3 Connect the other end of the S-video cable to the S-video input connector on your TV.

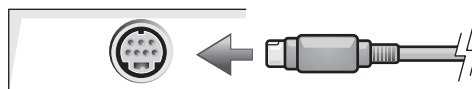

Changing the Display Settings

- 1 After you connect the TV, turn on the computer.
The Microsoft® Windows® desktop displays on the monitor.
- 2 Enable clone mode or extended desktop mode in the display settings.
 - In clone mode, the monitor and TV display the same image.
 - In extended desktop mode, you can drag objects from one screen to the other, effectively doubling the amount of viewable work space.

For information on changing the display settings for your graphics card, see the user's guide in the Help and Support Center (click the **Start** button, click **Help and Support**, click **User and system guides**, click **Device guides**, and then click the guide for your graphics card).

Setting Up a Home and Office Network

Connecting to a Network Adapter

 **NOTE:** Plug the network cable into the network adapter connector on the computer. Do not plug the network cable into the modem connector on the computer. Do not plug a network cable into a telephone wall jack.

- 1 Connect the network cable to the network adapter connector on the back of your computer. Insert the cable until it clicks into place, and then gently pull it to ensure that it is secure.
- 2 Connect the other end of the network cable to a network device.

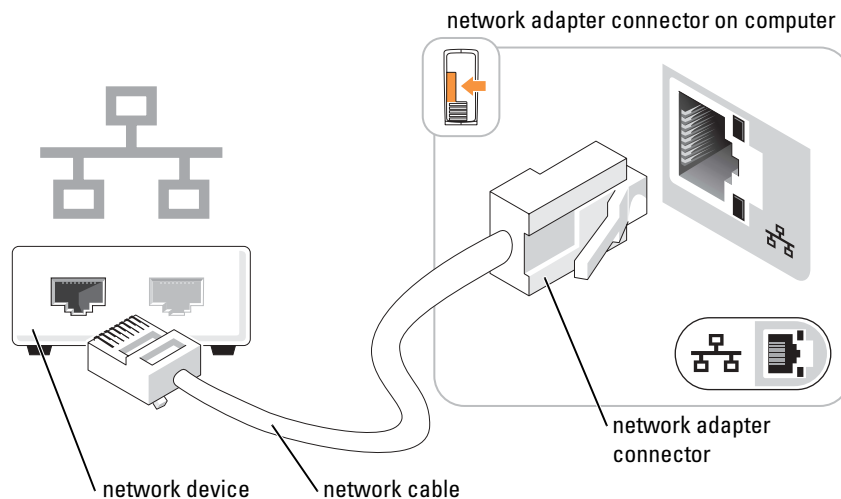

Network Setup Wizard

The Microsoft® Windows® XP operating system provides a Network Setup Wizard to guide you through the process of sharing files, printers, or an Internet connection between computers in a home or small office.

- 1 Click the **Start** button, point to **All Programs**→**Accessories**→**Communications**, and then click **Network Setup Wizard**.
- 2 On the welcome screen, click **Next**.
- 3 Click **Checklist for creating a network**.

 **NOTE:** Selecting the connection method **This computer connects directly to the Internet** enables the integrated firewall provided with Windows XP Service Pack 1 (SP1) or later operating systems.

- 4 Complete the checklist and required preparations.
- 5 Return to the Network Setup Wizard and follow the instructions on the screen.

Connecting to the Internet

 **NOTE:** ISPs and ISP offerings vary by country.

To connect to the Internet, you need a modem or network connection and an Internet service provider (ISP), such as AOL or MSN. Your ISP will offer one or more of the following Internet connection options:

- Dial-up connections that provide Internet access through a telephone line. Dial-up connections are considerably slower than DSL and cable modem connections.
- DSL connections that provide high-speed Internet access through your existing telephone line. With a DSL connection, you can access the Internet and use your telephone on the same line simultaneously.
- Cable modem connections that provide high-speed Internet access through your local cable TV line.

If you are using a dial-up connection, connect a telephone line to the modem connector on your computer and to the telephone wall jack before you set up your Internet connection. If you are using a DSL or cable modem connection, contact your ISP for setup instructions.

Setting Up Your Internet Connection

To set up an AOL or MSN connection:

- 1 Save and close any open files, and exit any open programs.
- 2 Double-click the **MSN Explorer** or **AOL** icon on the Microsoft® Windows® desktop.
- 3 Follow the instructions on the screen to complete the setup.

If you do not have an **MSN Explorer** or **AOL** icon on your desktop or if you want to set up an Internet connection with a different ISP:

- 1 Save and close any open files, and exit any open programs.
- 2 Click the **Start** button and click **Internet Explorer**.
The **New Connection Wizard** appears.
- 3 Click **Connect to the Internet**.
- 4 In the next window, click the appropriate option:
 - If you do not have an ISP and want to select one, click **Choose from a list of Internet service providers (ISPs)**.
 - If you have already obtained setup information from your ISP but you did not receive a setup CD, click **Set up my connection manually**.
 - If you have a CD, click **Use the CD I got from an ISP**.
- 5 Click **Next**.

If you selected **Set up my connection manually**, continue to step 6. Otherwise, follow the instructions on the screen to complete the setup.



NOTE: If you do not know which type of connection to select, contact your ISP.

- 6 Click the appropriate option under **How do you want to connect to the Internet?**, and then click **Next**.
- 7 Use the setup information provided by your ISP to complete the setup.

If you are having problems connecting to the Internet, see "E-Mail, Modem, and Internet Problems" on page 29. If you cannot connect to the Internet but have successfully connected in the past, the ISP might have a service outage. Contact your ISP to check the service status, or try connecting again later.

Playing a CD or DVD



NOTICE: Do not press down on the CD or DVD tray when you open or close it. Keep the tray closed when you are not using the drive.



NOTICE: Do not move the computer when you are playing CDs or DVDs.

- 1 Press the eject button on the front of the drive.
- 2 Place the disc, label side up in the center of the tray
- 3 Press the disc into the center of the tray until it clicks into place.











- 4 Press the eject button or gently push in the tray.







To format CDs for storing data, to create music CDs, or to copy CDs, see the CD software that came with your computer.

 **NOTE:** Ensure that you follow all copyright laws when you create CDs.

A CD player includes the following basic buttons:

	Play.
	Move backward within the current track.
	Pause.
	Move forward within the current track.
	Stop.
	Go to the previous track.
	Eject.
	Go to the next track.

A DVD player includes the following basic buttons:

	Stop.
	Play.
	Fast forward.
	Pause.
	Fast reverse.
	Go to the next title or chapter.
	Go to the previous title or chapter.

For more information on playing CDs or DVDs, click **Help** on the CD or DVD player (if available).

Adjusting the Volume

 **NOTE:** When the speakers are muted, you do not hear the CD or DVD playing.

- 1 Click the **Start** button, point to **All Programs** → **Accessories** → **Entertainment**, and then click **Volume Control**.
- 2 In the **Volume Control** window, click and drag the bar in the **Volume Control** column and slide it up or down to increase or decrease the volume.

For more information on volume control options, click **Help** in the **Volume Control** window.

Adjusting the Picture

If an error message notifies you that the current resolution and color depth are using too much memory and preventing DVD playback, adjust the display properties.

- 1 Click the **Start** button and click **Control Panel**.
- 2 Under **Pick a category**, click **Appearance and Themes**.
- 3 Under **Pick a task...**, click **Change the screen resolution**.
- 4 In the **Display Properties** window, click and drag the bar in **Screen resolution** to change the setting to 800 by 600 pixels.
- 5 Click the drop-down menu under **Color quality**, and then click **Medium (16 bit)**.
- 6 Click **OK**.

Copying CDs and DVDs

 **NOTE:** Ensure that you follow all copyright laws when you create CDs or DVDs.

This section applies only to computers that have a CD-R, DVD+RW, DVD+R, or DVD/CD-RW combo drive.

 **NOTE:** The types of CD or DVD drives offered by Dell may vary by country.

The following instructions show how to make an exact copy of a CD or DVD. You can also use Sonic RecordNow for other purposes, including creating CDs from audio files on your computer and creating MP3 CDs. For instructions, see the Sonic RecordNow documentation that came with your computer. Open Sonic RecordNow, click the question mark icon in the upper-right corner of the window, and then click the help or tutorial option.

How to Copy a CD or DVD

 **NOTE:** If you have a DVD/CD-RW combo drive and you experience recording problems, check for available software patches at the Sonic website at www.sonic.com.

Currently, five DVD-writable disc formats are available: DVD+R, DVD+RW, DVD-R, DVD-RW, and DVD-RAM. The DVD-writable drives installed in Dell™ computers can write to DVD+R and DVD+RW media, and can read DVD-R and DVD-RW media. However, DVD-writable drives do not write to and might not read DVD-RAM media. In addition, commercially available DVD players for home theater systems might not read all five formats.

 **NOTE:** Most commercial DVDs have copyright protection and cannot be copied using Sonic RecordNow.

- 1 Click the **Start** button, point to **All Programs**→ **Sonic**→ **RecordNow!**, and then click **RecordNow!**
- 2 Click either the audio tab or the data tab, depending on the kind of CD or DVD you want to copy.
- 3 Click **Exact Copy**.
- 4 To copy the CD or DVD:
 - *If you have one optical drive*, ensure that the settings are correct and click **Copy**. The computer reads your source CD or DVD disc and copies it to a temporary folder on your computer hard drive.
When prompted, insert a blank CD or DVD disc into the optical drive and click **OK**.
 - *If you have two optical drives*, select the drive into which you have inserted your source CD or DVD disc and click **Copy**. The computer copies the data on the CD or DVD to the blank CD or DVD.

After you finish copying the source CD or DVD, the CD or DVD that you created automatically ejects.

Using Blank CD-Rs, CD-RWs, DVD+R, and DVD+RW

Use blank CD-Rs to record music or permanently store data files. After creating a CD-R disc, you cannot write to that CD-R again (see the Sonic documentation for more information). Use blank CD-RWs to write to CD or to erase, rewrite, or update data on CDs.

Your DVD-writable drive can write to four different types of recording media—CD-Rs, CD-RWs (including high-speed CD-RWs), DVD+Rs, and DVD+RWs. Blank DVD+Rs can be used to permanently store large amounts of information. After you create a DVD+R, you may not be able to write to that disc again if the disc is "finalized" or "closed" during the final stage of the disc creation process. Use blank DVD+RWs if you plan to erase, rewrite, or update information on that disc later.

Helpful Tips

- Use Microsoft® Windows® Explorer to drag and drop files to a CD-R or CD-RW disc only after you start Sonic RecordNow and open a RecordNow project.
- You must use CD-R discs to burn music CDs that you want to play in regular stereos. CD-RWs do not play in most home or car stereos.

- You cannot create audio DVDs with Sonic RecordNow.
- Music MP3 files can be played only on MP3 players or on computers that have MP3 software installed.
- Do not burn a blank CD-R or CD-RW to its maximum capacity; for example, do not copy a 650-MB file to a 650-MB blank CD. The optical drive needs 1 or 2 MB of the blank CD to finalize the recording.
- Use a blank CD-RW to practice CD recording until you are familiar with CD recording techniques. If you make a mistake, you can erase the data on the CD-RWs and try again. You can also use blank CD-RWs to test music file projects before you record the project permanently to a blank CD-R.
- See the Sonic support website at support.sonic.com for additional information.

Power Management

The Microsoft® Windows® XP power management features can reduce the amount of electricity your computer uses when it is on and you are not using it. You can reduce power to just the monitor or the hard drive, or you can use standby mode or hibernate mode to reduce power to the entire computer. When the computer exits from a power conservation mode, the Windows desktop is restored to the state it was in before it entered the mode.



NOTE: Windows XP Professional includes security and networking features not available in Windows XP Home Edition. When a Windows XP Professional computer is connected to a network, different options related to security and networking appear in certain windows.

Standby Mode

Standby mode conserves power by turning off the display and the hard drive after a time-out. When the computer exits from standby mode, it returns to the operating state it was in before it entered standby mode.

To set standby mode to automatically activate after a defined period of inactivity:

- 1 Click the **Start** button and click **Control Panel**.
- 2 Under **Pick a category**, click **Performance and Maintenance**.
- 3 Under or pick a **Control Panel** icon, click **Power Options**.

To immediately activate standby mode without a period of inactivity, click the **Start** button, click **Turn Off Computer**, and then click **Stand by**.

To exit from standby mode, press a key on the keyboard or move the mouse.



NOTICE: If your computer loses power while in standby mode, it may lose data.

Hibernate Mode

Hibernate mode conserves power by copying system data to a reserved area on the hard drive and then completely turning off the computer. When the computer exits from hibernate mode, the desktop is restored to the state it was in before it entered hibernate mode.

To activate hibernate mode:

- 1 Click the **Start** button and click **Control Panel**.
- 2 Under **Pick a category**, click **Performance and Maintenance**.
- 3 Under or pick a **Control Panel icon**, click **Power Options**.
- 4 Define your hibernate settings on the **Power Schemes** tab, **Advanced** tab, and **Hibernate** tab.

To exit from hibernate mode, press the power button. The computer may take a short time to exit from hibernate mode. Pressing a key on the keyboard or moving the mouse does not bring the computer out of hibernation, because the keyboard and the mouse do not function when the computer is in hibernate mode.

Because hibernate mode requires a special file on your hard drive with enough disk space to store the contents of the computer memory, Dell creates an appropriately sized hibernate mode file before shipping the computer to you. If the computer's hard drive becomes corrupted, Windows XP recreates the hibernate file automatically.

Power Options Properties

Define your standby mode settings, hibernate mode settings, and other power settings in the **Power Options Properties** window. To access the **Power Options Properties** window:

- 1 Click the **Start** button and click **Control Panel**.
- 2 Under **Pick a category**, click **Performance and Maintenance**.
- 3 Under or pick a **Control Panel icon**, click **Power Options**.
- 4 Define your power settings on the **Power Schemes** tab, **Advanced** tab, and **Hibernate** tab.

Power Schemes Tab

Each standard power setting is called a scheme. If you want to select one of the standard Windows schemes installed on your computer, choose a scheme from the **Power schemes** drop-down menu. The settings for each scheme appear in the fields below the scheme name. Each scheme has different settings for starting standby mode or hibernate mode, turning off the monitor, and turning off the hard drive.

The **Power schemes** drop-down menu displays the following schemes:

- **Always On** (default) — If you want to use your computer with no power conservation.
- **Home/Office Desk** — If you use your computer as a home or office computer and you require minimal power conservation.
- **Portable/Laptop** — If your computer is a portable computer that you use for traveling.

- **Presentation** — If you want your computer to run without interruption (using no power conservation).
- **Minimal Power Management** — If you want your computer to run with minimal power conservation.
- **Max Battery** — If your computer is a portable computer and you run your computer from batteries for extended periods of time.

If you want to change the default settings for a scheme, click the drop-down menu in the **Turn off monitor**, **Turn off hard disks**, **System stand by**, or **System hibernates** field, and then select a time-out from the displayed list. Changing the time-out for a scheme field permanently changes the default settings for that scheme, unless you click **Save As** and enter a new name for the changed scheme.



NOTICE: If you set the hard drive (hard disk) to time-out before the monitor does, your computer may appear to be locked up. To recover, press any key on the keyboard or click the mouse. To avoid this problem, always set the monitor to time-out before the hard drive.

Advanced Tab

The **Advanced** tab allows you to:

- Place the power options icon  in the Windows taskbar for quick access.
- Set the computer to prompt you for your Windows password before the computer exits from standby mode or hibernate mode.
- Program the power button to activate standby mode, activate hibernate mode, or turn off the computer.

To program these functions, click an option from the corresponding drop-down menu and click **OK**.

Hibernate Tab

The **Hibernate** tab allows you to enable hibernate mode. If you want to use the hibernate settings you defined on the **Power Schemes** tab, click the **Enable hibernate support** check box on the **Hibernate** tab.

For more information on power management options:

- 1 Click the **Start** button and click **Help and Support**.
- 2 In the **Help and Support** window, click **Performance and maintenance**.
- 3 In the **Performance and maintenance** window, click **Conserving power on your computer**.

Hyper-Threading

Hyper-Threading is an Intel[®] technology that can enhance overall computer performance by allowing one physical processor to function as two logical processors, capable of performing certain tasks simultaneously. It is recommended that you use the Microsoft[®] Windows[®] XP Service Pack 1

(SP1) or later operating system because Windows XP is optimized to take advantage of Hyper-Threading technology. While many programs can benefit from Hyper-Threading, some programs have not been optimized for Hyper-Threading and may require an update from the software manufacturer. Contact the software manufacturer for updates and information about using Hyper-Threading with your software.

To determine if your computer is using Hyper-Threading technology:

- 1** Click the **Start** button, right-click **My Computer**, and then click **Properties**.
- 2** Click **Hardware** and click **Device Manager**.
- 3** In the **Device Manager** window, click the plus (+) sign next to **Processors**. If Hyper-Threading is enabled, the processor is listed twice.

You can enable or disable Hyper-Threading through system setup. For more information on accessing system setup, see page 98.

Solving Problems

Troubleshooting Tips

Follow these tips when you troubleshoot your computer:

- If you added or removed a part before the problem started, review the installation procedures and ensure that the part is correctly installed.
- If a peripheral device does not work, ensure that the device is properly connected.
- If an error message appears on the screen, write down the exact message. This message may help technical support personnel diagnose and fix the problem(s).
- If an error message occurs in a program, see the program's documentation.

Battery Problems



CAUTION: There is a danger of a new battery exploding if it is incorrectly installed. Replace the battery only with the same or equivalent type recommended by the manufacturer. Discard used batteries according to the manufacturer's instructions.



CAUTION: Before you begin any of the procedures in this section, follow the safety instructions located in the *Product Information Guide*.

REPLACE THE BATTERY — If you have to repeatedly reset time and date information after turning on the computer, or if an incorrect time or date displays during start-up, replace the battery (see page 89). If the battery still does not work properly, contact Dell (see page 108).

Drive Problems



CAUTION: Before you begin any of the procedures in this section, follow the safety instructions located in the *Product Information Guide*.

ENSURE THAT MICROSOFT® WINDOWS® RECOGNIZES THE DRIVE — Click the Start button and click My Computer. If the floppy, CD, or DVD drive, is not listed, perform a full scan with your antivirus software to check for and remove viruses. Viruses can sometimes prevent Windows from recognizing the drive.

TEST THE DRIVE —

- Insert another floppy disk, CD, or DVD to eliminate the possibility that the original one is defective.
- Insert a bootable floppy disk and restart the computer.

NOTE: This system supports an optional USB floppy drive.

CLEAN THE DRIVE OR DISK — See page 105.

CHECK THE CABLE CONNECTIONS

RUN THE HARDWARE TROUBLESHOOTER — See page 49.

RUN THE DELL DIAGNOSTICS — See page 46.

CD and DVD drive problems

 **NOTE:** High-speed CD or DVD drive vibration is normal and may cause noise, which does not indicate a defect in the drive or the CD or DVD.

 **NOTE:** Because of different regions worldwide and different disc formats, not all DVD titles work in all DVD drives.

ADJUST THE WINDOWS VOLUME CONTROL —

- Click the speaker icon in the lower-right corner of your screen.
- Ensure that the volume is turned up by clicking the sidebar and dragging it up.
- Ensure that the sound is not muted by clicking any boxes that are checked.

CHECK THE SPEAKERS AND SUBWOOFER — See "Sound and Speaker Problems" on page 39.

Problems writing to a CD/DVD-RW drive

CLOSE OTHER PROGRAMS — The CD/DVD-RW drive must receive a steady stream of data when writing. If the stream is interrupted, an error occurs. Try closing all programs before you write to the CD/DVD-RW.

TURN OFF STANDBY MODE IN WINDOWS BEFORE WRITING TO A CD/DVD-RW DISC — See page 23 or search for the keyword *standby* in Windows Help for information on power management modes.

Hard drive problems

RUN CHECK DISK —

- 1 Click the **Start** button and click **My Computer**.
- 2 Right-click **Local Disk C:**.
- 3 Click **Properties**.
- 4 Click the **Tools** tab.
- 5 Under **Error-checking**, click **Check Now**.
- 6 Click **Scan for and attempt recovery of bad sectors**.
- 7 Click **Start**.

E-Mail, Modem, and Internet Problems



CAUTION: Before you begin any of the procedures in this section, follow the safety instructions located in the *Product Information Guide*.



NOTE: Connect the modem to an analog telephone jack only. The modem does not operate while it is connected to a digital telephone network.

CHECK THE MICROSOFT OUTLOOK® EXPRESS SECURITY SETTINGS — If you cannot open your e-mail attachments:

- 1 In Outlook Express, click **Tools**, click **Options**, and then click **Security**.
- 2 Click **Do not allow attachments** to remove the checkmark.

CHECK THE TELEPHONE LINE CONNECTION —

CHECK THE TELEPHONE JACK —

CONNECT THE MODEM DIRECTLY TO THE TELEPHONE WALL JACK —

USE A DIFFERENT TELEPHONE LINE —

- Verify that the telephone line is connected to the jack on the modem. (The jack has either a green label or a connector-shaped icon next to it.)
- Ensure that you hear or feel a click when you insert the telephone line connector into the modem.
- Disconnect the telephone line from the modem and connect it to a telephone. Listen for a dial tone.
- If you have other telephone devices sharing the line, such as an answering machine, fax machine, surge protector, or line splitter, then bypass them and use the telephone to connect the modem directly to the telephone wall jack. If you are using a line that is 3 m (10 ft) or more in length, try a shorter one.

RUN THE MODEM HELPER DIAGNOSTICS — Click the **Start** button, point to **All Programs**, and then click **Modem Helper**. Follow the instructions on the screen to identify and resolve modem problems. (Modem Helper is not available on certain computers.)

VERIFY THAT THE MODEM IS COMMUNICATING WITH WINDOWS —

- 1 Click the **Start** button and click **Control Panel**.
 - 2 Click **Printers and Other Hardware**.
 - 3 Click **Phone and Modem Options**.
 - 4 Click the **Modems** tab.
 - 5 Click the COM port for your modem.
 - 6 Click **Properties**, click the **Diagnostics** tab, and then click **Query Modem** to verify that the modem is communicating with Windows.
- If all commands receive responses, the modem is operating properly.

ENSURE THAT YOU ARE CONNECTED TO THE INTERNET — Ensure that you have subscribed to an Internet provider. With the Outlook Express e-mail program open, click **File**. If **Work Offline** has a checkmark next to it, click the checkmark to remove it and connect to the Internet. For help, contact your Internet service provider.

Error Messages



CAUTION: Before you begin any of the procedures in this section, follow the safety instructions located in the *Product Information Guide*.

If the message is not listed, see the documentation for the operating system or the program that was running when the message appeared.

A FILENAME CANNOT CONTAIN ANY OF THE FOLLOWING CHARACTERS: \ / : * ? " < > | — Do not use these characters in filenames.

A REQUIRED .DLL FILE WAS NOT FOUND — The program that you are trying to open is missing an essential file. To remove and then reinstall the program:

- 1 Click the **Start** button, click **Control Panel**, and then click **Add or Remove Programs**.
- 2 Select the program you want to remove.
- 3 Click the **Change or Remove Program** icon.
- 4 See the program documentation for installation instructions.

drive letter : \ IS NOT ACCESSIBLE. THE DEVICE IS NOT READY — The drive cannot read the disk. Insert a disk into the drive and try again.

INSERT BOOTABLE MEDIA — Insert a bootable floppy disk or CD.

NOTE: This system supports an optional USB floppy drive.

NON-SYSTEM DISK ERROR — Remove the floppy disk from the drive and restart your computer.

NOTE: This system supports an optional USB floppy drive.

NOT ENOUGH MEMORY OR RESOURCES. CLOSE SOME PROGRAMS AND TRY AGAIN — Close all windows and open the program that you want to use. In some cases, you might have to restart your computer to restore computer resources. If so, run the program that you want to use first.

OPERATING SYSTEM NOT FOUND — Contact Dell (see page 108).

Media Card Reader Problems



CAUTION: Before you begin any of the procedures in this section, follow the safety instructions located in the *Product Information Guide*.

NO DRIVE LETTER IS ASSIGNED —

When Microsoft Windows XP detects the media card reader, the device is automatically assigned a drive letter as the next logical drive after all other physical drives in the system. If the next logical drive after the physical drives is mapped to a network drive, Windows XP does not automatically assign a drive letter to the media card reader.

To manually assign a drive for the media card reader:

- 1 Right-click **My Computer** and select **Manage**.
- 2 Select the **Disk Management** option.
- 3 Right-click the corresponding drive letter in the right pane that needs to be changed.
- 4 Select **Drive Letter and Paths**.
- 5 From the drop-down list, select the new drive letter assignment for the media card reader.
- 6 Click **OK** to confirm your selection.

NOTE: The media card reader appears as a mapped drive only when it is connected. Each of the four media card reader slots are mapped to a drive even if no media is installed. If you attempt to access the media card reader when no media is inserted, you are prompted to insert media.

IEEE 1394 Device Problems



CAUTION: Before you begin any of the procedures in this section, follow the safety instructions located in the *Product Information Guide*.

ENSURE THAT THE CABLE FOR THE IEEE 1394 DEVICE IS PROPERLY INSERTED INTO THE DEVICE AND INTO THE CONNECTOR ON THE COMPUTER

ENSURE THAT THE IEEE 1394 DEVICE IS RECOGNIZED BY WINDOWS —

- 1 Click the Start button and click Control Panel.
- 2 Click Printers and Other Hardware.
If your IEEE 1394 device is listed, Windows recognizes the device.

IF YOU HAVE PROBLEMS WITH A DELL IEEE 1394 DEVICE — Contact Dell (see page 108).

IF YOU HAVE PROBLEMS WITH A NON-DELL IEEE 1394 DEVICE — Contact the manufacturer of the IEEE 1394 device.

Keyboard Problems



CAUTION: Before you begin any of the procedures in this section, follow the safety instructions located in the *Product Information Guide*.

CHECK THE KEYBOARD CABLE —

- Ensure that the keyboard cable is firmly connected to the computer.
- Reconnect the keyboard cable as shown on the setup diagram for your computer.
- Check the cable connector for damaged or frayed cables.
- Remove keyboard extension cables and connect the keyboard directly to the computer.

TEST THE KEYBOARD — Connect a properly working keyboard to the computer, and try using the keyboard.

RUN THE HARDWARE TROUBLESHOOTER — See page 49.

Lockups and Software Problems



CAUTION: Before you begin any of the procedures in this section, follow the safety instructions located in the *Product Information Guide*.

The computer does not start up

CHECK THE DIAGNOSTIC LIGHTS — See page 43.

ENSURE THAT THE POWER CABLE IS FIRMLY CONNECTED TO THE COMPUTER AND TO THE ELECTRICAL OUTLET

The computer stops responding



NOTICE: You might lose data if you are unable to perform an operating system shutdown.

TURN THE COMPUTER OFF — If you are unable to get a response by pressing a key on your keyboard or moving your mouse, press and hold the power button for at least 8 to 10 seconds until the computer turns off. Then restart your computer.

A program stops responding

END THE PROGRAM —

- 1 Press <Ctrl><Shift><Esc> simultaneously.
- 2 Click **Applications**.
- 3 Click the program that is no longer responding.
- 4 Click **End Task**.

A program crashes repeatedly



NOTE: Software usually includes installation instructions in its documentation or on a floppy disk or CD.

CHECK THE SOFTWARE DOCUMENTATION — If necessary, uninstall and then reinstall the program.

A program is designed for an earlier Windows operating system

RUN THE PROGRAM COMPATIBILITY WIZARD —

The Program Compatibility Wizard configures a program so that it runs in an environment similar to non-Windows XP operating system environments.

- 1 Click the **Start** button, point to **All Programs**→**Accessories**, and then click **Program Compatibility Wizard**.
- 2 In the welcome screen, click **Next**.
- 3 Follow the instructions on the screen.

A solid blue screen appears

TURN THE COMPUTER OFF — If you are unable to get a response by pressing a key on your keyboard or moving your mouse, press and hold the power button for at least 8 to 10 seconds until the computer turns off. Then restart your computer.

Other software problems

CHECK THE SOFTWARE DOCUMENTATION OR CONTACT THE SOFTWARE MANUFACTURER FOR TROUBLESHOOTING INFORMATION —

- Ensure that the program is compatible with the operating system installed on your computer.
- Ensure that your computer meets the minimum hardware requirements needed to run the software. See the software documentation for information.
- Ensure that the program is installed and configured properly.
- Verify that the device drivers do not conflict with the program.
- If necessary, uninstall and then reinstall the program.

BACK UP YOUR FILES IMMEDIATELY

USE A VIRUS-SCANNING PROGRAM TO CHECK THE HARD DRIVE, FLOPPY DISKS, OR CDS

SAVE AND CLOSE ANY OPEN FILES OR PROGRAMS AND SHUT DOWN YOUR COMPUTER THROUGH THE START MENU

Memory Problems



CAUTION: Before you begin any of the procedures in this section, follow the safety instructions located in the *Product Information Guide*.

IF YOU RECEIVE AN INSUFFICIENT MEMORY MESSAGE —

- Save and close any open files and exit any open programs you are not using to see if that resolves the problem.
- See the software documentation for minimum memory requirements. If necessary, install additional memory (see page 64).
- Reseat the memory modules (see page 64) to ensure that your computer is successfully communicating with the memory.
- Run the Dell Diagnostics (see page 46).

IF YOU EXPERIENCE OTHER MEMORY PROBLEMS —

- Reseat the memory modules (see page 64) to ensure that your computer is successfully communicating with the memory.
- Ensure that you are following the memory installation guidelines (see page 63).
- Your computer supports DDR2 memory. For more information about the type of memory supported by your computer, see "Memory" on page 93.
- Run the Dell Diagnostics (see page 46).

Mouse Problems



CAUTION: Before you begin any of the procedures in this section, follow the safety instructions located in the *Product Information Guide*.

CLEAN THE MOUSE — See page 105.

CHECK THE MOUSE CABLE —

- 1 Check the cable connector for damaged or frayed cables.
- 2 Remove mouse extension cables, if used, and connect the mouse directly to the computer.
- 3 Reconnect the mouse cable as shown on the setup diagram for your computer.

RESTART THE COMPUTER —

- 1 Simultaneously press <Ctrl> <Esc> to display the **Start** menu.
- 2 Type **u**, press the keyboard arrow keys to highlight **Shut down** or **Turn Off**, and then press <Enter>.
- 3 After the computer turns off, reconnect the mouse cable as shown on the setup diagram for your computer.
- 4 Start the computer.

TEST THE MOUSE — Connect a properly working mouse to the computer, and try using the mouse.

CHECK THE MOUSE SETTINGS —

- 1 Click the **Start** button, click **Control Panel**, and then click **Printers and Other Hardware**.
- 2 Click **Mouse**.
- 3 Try adjusting the settings.

REINSTALL THE MOUSE DRIVER — See page 48.

RUN THE HARDWARE TROUBLESHOOTER — See page 49.

Network Problems

 **CAUTION:** Before you begin any of the procedures in this section, follow the safety instructions located in the *Product Information Guide*.

CHECK THE NETWORK CABLE CONNECTOR — Ensure that the network cable is firmly inserted into both the network connector on the back of the computer and the network jack.

CHECK THE NETWORK LIGHTS ON THE BACK OF THE COMPUTER — If the link integrity light is off, that indicates no network communication exists. Replace the network cable. For a description of network lights, see "Controls and Lights" on page 96.

RESTART THE COMPUTER AND LOG ON TO THE NETWORK AGAIN

CHECK YOUR NETWORK SETTINGS — Contact your network administrator or the person who set up your network to verify that your network settings are correct and that the network is functioning.

RUN THE HARDWARE TROUBLESHOOTER — See page 49.

Power Problems

 **CAUTION:** Before you begin any of the procedures in this section, follow the safety instructions located in the *Product Information Guide*.

IF THE POWER LIGHT IS GREEN AND THE COMPUTER IS NOT RESPONDING — See "Diagnostic Lights" on page 43.

IF THE POWER LIGHT IS BLINKING GREEN — The computer is in standby mode. Press a key on the keyboard, move the mouse, or press the power button to resume normal operation.

IF THE POWER LIGHT IS OFF — The computer is either turned off or is not receiving power.

- Reseat the power cable into both the power connector on the back of the computer and the electrical outlet.
- If the computer is plugged into a power strip, ensure that the power strip is plugged into an electrical outlet and that the power strip is turned on. Also bypass power protection devices, power strips, and power extension cables to verify that the computer turns on properly.
- Ensure that the electrical outlet is working by testing it with another device, such as a lamp.
- Ensure that the main power cable and front panel cable are securely connected to the system board (see page 62).

IF THE POWER LIGHT IS STEADY AMBER — A device might be malfunctioning or incorrectly installed.

- Ensure that the processor cable is securely connected to the system board (see page 62).
- Remove and then reinstall the memory modules (see page 64).
- Remove and then reinstall any cards (see page 66).
- Remove and then reinstall the graphics card, if applicable (see page 67).

IF THE POWER LIGHT IS BLINKING AMBER — The computer is receiving electrical power, but an internal power problem might exist.

- Ensure that the voltage selection switch is set to match the AC power at your location (if applicable).
- Ensure that the processor power cable is securely connected to the system board (see page 62).

ELIMINATE INTERFERENCE — Some possible causes of interference are:

- Power, keyboard, and mouse extension cables
- Too many devices on a power strip
- Multiple power strips connected to the same electrical outlet

Printer Problems



CAUTION: Before you begin any of the procedures in this section, follow the safety instructions located in the *Product Information Guide*.



NOTE: If you need technical assistance for your printer, contact the printer's manufacturer.

CHECK THE PRINTER DOCUMENTATION — See the printer documentation for setup and troubleshooting information.

ENSURE THAT THE PRINTER IS TURNED ON

CHECK THE PRINTER CABLE CONNECTIONS —

- See the printer documentation for cable connection information.
- Ensure that the printer cables are securely connected to the printer and the computer (see page 13).

TEST THE ELECTRICAL OUTLET — Ensure that the electrical outlet is working by testing it with another device, such as a lamp.

VERIFY THAT THE PRINTER IS RECOGNIZED BY WINDOWS —

- 1 Click the **Start** button, click **Control Panel**, and then click **Printers and Other Hardware**.
- 2 Click **View installed printers or fax printers**.
If the printer is listed, right-click the printer icon.
- 3 Click **Properties** and click the **Ports** tab. For a USB printer, ensure that the **Print to the following port(s):** setting is **USB**.

REINSTALL THE PRINTER DRIVER — See the printer documentation for instructions.

Scanner Problems



CAUTION: Before you begin any of the procedures in this section, follow the safety instructions located in the *Product Information Guide*.



NOTE: If you need technical assistance for your scanner, contact the scanner's manufacturer.

CHECK THE SCANNER DOCUMENTATION — See the scanner documentation for setup and troubleshooting information.

UNLOCK THE SCANNER — Ensure that your scanner is unlocked if it has a locking tab or button.

RESTART THE COMPUTER AND TRY THE SCANNER AGAIN**CHECK THE CABLE CONNECTIONS —**

- See the scanner documentation for cable connection information.
- Ensure that the scanner cables are securely connected to the scanner and the computer.

VERIFY THAT THE SCANNER IS RECOGNIZED BY MICROSOFT WINDOWS —

1 Click the Start button, click Control Panel, and then click Printers and Other Hardware.

2 Click Scanners and Cameras.

If your scanner is listed, Windows recognizes the scanner.

REINSTALL THE SCANNER DRIVER — See the scanner documentation for instructions.

Sound and Speaker Problems



CAUTION: Before you begin any of the procedures in this section, follow the safety instructions located in the *Product Information Guide*.

No sound from speakers



NOTE: The volume control in some MP3 players overrides the Windows volume setting. If you have been listening to MP3 songs, ensure that you did not turn the player volume down or off.

CHECK THE SPEAKER CABLE CONNECTIONS — Ensure that the speakers are connected as shown on the setup diagram supplied with the speakers. If you purchased a sound card, ensure that the speakers are connected to the card.

ENSURE THAT THE SUBWOOFER AND THE SPEAKERS ARE TURNED ON — See the setup diagram supplied with the speakers. If your speakers have volume controls, adjust the volume, bass, or treble to eliminate distortion.

ADJUST THE WINDOWS VOLUME CONTROL — Click or double-click the speaker icon in the lower-right corner of your screen. Ensure that the volume is turned up and that the sound is not muted.

DISCONNECT HEADPHONES FROM THE HEADPHONE CONNECTOR — Sound from the speakers is automatically disabled when headphones are connected to the computer's front-panel headphone connector.

TEST THE ELECTRICAL OUTLET — Ensure that the electrical outlet is working by testing it with another device, such as a lamp.

ELIMINATE POSSIBLE INTERFERENCE — Turn off nearby fans, fluorescent lights, or halogen lamps to check for interference.

RUN THE SPEAKER DIAGNOSTICS — SEE YOUR SPEAKER DOCUMENTATION FOR MORE INFORMATION.

REINSTALL THE SOUND DRIVER — See page 48.

RUN THE HARDWARE TROUBLESHOOTER — See page 49.

No sound from headphones

CHECK THE HEADPHONE CABLE CONNECTION — Ensure that the headphone cable is securely inserted into the headphone connector (see page 57).

ADJUST THE WINDOWS VOLUME CONTROL — Click or double-click the speaker icon in the lower-right corner of your screen. Ensure that the volume is turned up and that the sound is not muted.

Video and Monitor Problems



NOTE: See the monitor documentation for troubleshooting procedures.



CAUTION: Before you begin any of the procedures in this section, follow the safety instructions located in the *Product Information Guide*.

If the screen is blank

CHECK THE MONITOR CABLE CONNECTION —

- Ensure that the graphics cable is connected as shown on the setup diagram for your computer.
- If you are using a graphics extension cable and removing the cable solves the problem, the cable is defective.
- Swap the computer and monitor power cables to determine if the power cable is defective.
- Check the connector for bent or broken pins. (It is normal for monitor cable connectors to have missing pins.)

CHECK THE MONITOR POWER LIGHT — If the power light is off, firmly press the button to ensure that the monitor is turned on. If the power light is lit or blinking, the monitor has power. If the power light is blinking, press a key on the keyboard or move the mouse.

TEST THE ELECTRICAL OUTLET — Ensure that the electrical outlet is working by testing it with another device, such as a lamp.

CHECK THE DIAGNOSTIC LIGHTS — See page 43.

If the screen is difficult to read

CHECK THE MONITOR SETTINGS — See the monitor documentation for instructions on adjusting the contrast and brightness, demagnetizing (degaussing) the monitor, and running the monitor self-test.

MOVE THE SUBWOOFER AWAY FROM THE MONITOR — If your speaker system includes a subwoofer, ensure that the subwoofer is at least 60 cm (2 ft) away from the monitor.

MOVE THE MONITOR AWAY FROM EXTERNAL POWER SOURCES — Fans, fluorescent lights, halogen lamps, and other electrical devices can cause the screen image to appear "shaky." Turn off nearby devices to check for interference.

ROTATE THE MONITOR TO ELIMINATE SUNLIGHT GLARE AND POSSIBLE INTERFERENCE

ADJUST THE WINDOWS DISPLAY SETTINGS —

- 1** Click the **Start** button, click **Control Panel**, and then click **Appearance and Themes**.
- 2** Click **Display** and click the **Settings** tab.
- 3** Try different settings for **Screen resolution** and **Color quality**.

Troubleshooting Tools





Diagnostic Lights





CAUTION: Before you begin any of the procedures in this section, follow the safety instructions located in the *Product Information Guide*.

To help you troubleshoot a problem, your computer has four lights labeled "1," "2," "3," and "4" on the back panel (see page 57). When the computer starts normally, the lights flash. After the computer starts, all four lights display solid green. If the computer malfunctions, the color and sequence of the lights identify the problem.

Light Pattern	Problem Description	Suggested Resolution
① ② ③ ④	The computer is in a normal "off" condition or a possible pre-BIOS failure has occurred.	Plug the computer into a working electrical outlet and press the power button.
① ② ③ ④	A possible processor failure has occurred.	Contact Dell (see page 108).
① ② ③ ④	Memory modules are detected, but a memory failure has occurred.	<ul style="list-style-type: none"> • If you have two or more memory modules installed, remove the modules, reinstall one module (see page 64), and then restart the computer. If the computer starts normally, reinstall an additional module. Continue until you have identified a faulty module or reinstalled all modules without error. • If available, install properly working memory of the same type into your computer (see page 63). • If the problem persists, contact Dell (see page 108).

Light Pattern	Problem Description	Suggested Resolution
	A possible graphics card failure has occurred.	<ul style="list-style-type: none"> • If the computer has a graphics card, remove the card, reinstall it (see page 66), and then restart the computer. • If the problem still exists, install a graphics card that you know works and restart the computer. • If the problem persists or the computer has integrated graphics, contact Dell (see page 108).
	A possible floppy or hard drive failure has occurred.	Reseat all power and data cables and restart the computer.
	A possible USB failure has occurred.	Reinstall all USB devices, check cable connections, and then restart the computer.
	No memory modules are detected.	<ul style="list-style-type: none"> • If you have two or more memory modules installed, remove the modules, reinstall one module (see page 64), and then restart the computer. If the computer starts normally, reinstall an additional module. Continue until you have identified a faulty module or reinstalled all modules without error. • If available, install properly working memory of the same type into your computer (see page 63). • If the problem persists, contact Dell (see page 108).
	Memory modules are detected, but a memory configuration or compatibility error exists.	<ul style="list-style-type: none"> • Ensure that no special memory module/memory connector placement requirements exist (see page 63). • Verify that the memory modules that you are installing are compatible with your computer (see page 63). • If the problem persists, contact Dell (see page 108).

Light Pattern	Problem Description	Suggested Resolution
	<p>A possible expansion card failure has occurred.</p>	<ol style="list-style-type: none"> 1 Determine if a conflict exists by removing a card (not a graphics card) (see page 66) and restarting the computer. 2 If the problem persists, reinstall the card that you removed, remove a different card, and then restart the computer. 3 Repeat this process for each card. If the computer starts normally, troubleshoot the last card removed from the computer for resource conflicts (see page 49). 4 If the problem persists, contact Dell (see page 108).
	<p>Another failure has occurred.</p>	<ul style="list-style-type: none"> • Ensure that the cables are properly connected to the system board from the hard drive, CD drive, and DVD drive (see page 62). • If there is an error message on your screen identifying a problem with a device (such as the floppy drive or hard drive), check the device to make sure it is functioning properly. • The operating system is attempting to boot from a device (such as the floppy drive or hard drive); check system setup (see page 97) to make sure the boot sequence is correct for the devices installed on your computer. • If the problem persists, contact Dell (see page 108).
	<p>The computer is in a normal operating condition after POST.</p>	<p>None.</p>

Dell Diagnostics



CAUTION: Before you begin any of the procedures in this section, follow the safety instructions located in the *Product Information Guide*.

When to Use the Dell Diagnostics

If you experience a problem with your computer, perform the checks in "Solving Problems" on page 27 and run the Dell Diagnostics before you contact Dell for technical assistance.



NOTICE: The Dell Diagnostics works only on Dell™ computers.

- 1 Turn on (or restart) your computer.
- 2 When the DELL™ logo appears, press <F12> immediately.

If you wait too long and the operating system logo appears, continue to wait until you see the Microsoft® Windows® desktop. Then shut down your computer (see page 53) and try again.

- 3 When the boot device list appears, highlight **Boot to Utility Partition** and press <Enter>.
- 4 When the Dell Diagnostics **Main Menu** appears, select the test you want to run (see page 46).

Dell Diagnostics Main Menu

- 1 After the Dell Diagnostics loads and the **Main Menu** screen appears, click the button for the option you want.

Option	Function
Express Test	Performs a quick test of devices. This test typically takes 10 to 20 minutes and requires no interaction on your part. Run Express Test first to increase the possibility of tracing the problem quickly.
Extended Test	Performs a thorough check of devices. This test typically takes an hour or more and requires you to answer questions periodically.
Custom Test	Tests a specific device. You can customize the tests you want to run.
Symptom Tree	Lists the most common symptoms encountered and allows you to select a test based on the symptom of the problem you are having.

- 2 If a problem is encountered during a test, a message appears with an error code and a description of the problem. Write down the error code and problem description and follow the instructions on the screen.

If you cannot resolve the error condition, contact Dell (see page 108).

 **NOTE:** The Service Tag for your computer is located at the top of each test screen. If you contact Dell, technical support will ask for your Service Tag.

- 3 If you run a test from the **Custom Test** or **Symptom Tree** option, click the applicable tab described in the following table for more information.

Tab	Function
Results	Displays the results of the test and any error conditions encountered.
Errors	Displays error conditions encountered, error codes, and the problem description.
Help	Describes the test and may indicate requirements for running the test.
Configuration	Displays your hardware configuration for the selected device. The Dell Diagnostics obtains configuration information for all devices from system setup, memory, and various internal tests, and it displays the information in the device list in the left pane of the screen. The device list may not display the names of all the components installed on your computer or all devices attached to your computer.
Parameters	Allows you to customize the test by changing the test settings.

- 4 Close the test screen to return to the **Main Menu** screen. To exit the Dell Diagnostics and restart the computer, close the **Main Menu** screen.

Drivers

What Is a Driver?

A driver is a program that controls a device such as a printer, mouse, or keyboard. All devices require a driver program.

A driver acts like a translator between the device and any other programs that use the device. Each device has its own set of specialized commands that only its driver recognizes.

Dell ships your computer to you with required drivers already installed—no further installation or configuration is needed.

Many drivers, such as the keyboard driver, come with your Microsoft® Windows® operating system. You may need to install drivers if you:

- Upgrade your operating system.
 - Reinstall your operating system.
 - Connect or install a new device.
- #### Identifying Drivers

If you experience a problem with any device, identify whether the driver is the source of your problem and, if necessary, update the driver.

Windows XP

- 1 Click the **Start** button and click **Control Panel**.
- 2 Under **Pick a Category**, click **Performance and Maintenance**.
- 3 Click **System**.
- 4 In the **System Properties** window, click the **Hardware** tab.
- 5 Click **Device Manager**.
- 6 Scroll down the list to see if any device has an exclamation point (a yellow circle with a [!]) on the device icon.

If an exclamation point is next to the device name, you may need to reinstall the driver or install a new driver (see page 47).

Reinstalling Drivers



NOTICE: The Dell Support website at support.dell.com provides approved drivers for Dell™ computers. If you install drivers obtained from other sources, your computer might not work correctly.

Using Windows XP Device Driver Rollback

If a problem occurs on your computer after you install or update a driver, use Windows XP Device Driver Rollback to replace the driver with the previously installed version.

- 1 Click the **Start** button and click **Control Panel**.
- 2 Under **Pick a Category**, click **Performance and Maintenance**.
- 3 Click **System**.
- 4 In the **System Properties** window, click the **Hardware** tab.
- 5 Click **Device Manager**.
- 6 Right-click the device for which the new driver was installed and click **Properties**.
- 7 Click the **Drivers** tab.
- 8 Click **Roll Back Driver**.

If Device Driver Rollback does not resolve the problem, then use System Restore to return your computer to the operating state that existed before you installed the new driver.

Manually Reinstalling Drivers

- 1 After copying the driver files to your hard drive, click the **Start** button and right-click **My Computer**.
- 2 Click **Properties**.

- 3 Click the **Hardware** tab and click **Device Manager**.
- 4 Double-click the type of device for which you are installing the driver.
- 5 Double-click the name of the device for which you are installing the driver.
- 6 Click the **Driver** tab and click **Update Driver**.
- 7 Click **Install from a list or specific location (Advanced)** and click **Next**.
- 8 Click **Browse** and browse to the location to which you previously extracted the driver files.
- 9 When the name of the appropriate driver appears, click **Next**.
- 10 Click **Finish** and restart your computer.

Resolving Software and Hardware Incompatibilities

If a device is either not detected during the operating system setup or is detected but incorrectly configured, you can use the Hardware Troubleshooter to resolve the incompatibility.

To resolve incompatibilities using the Hardware Troubleshooter:

- 1 Click the **Start** button and click **Help and Support**.
- 2 Type `hardware troubleshooter` in the **Search** field and click the arrow to start the search.
- 3 Click **Hardware Troubleshooter** in the **Search Results** list.
- 4 In the **Hardware Troubleshooter** list, click **I need to resolve a hardware conflict on my computer**, and click **Next**.

Restoring Your Operating System

You can restore your operating system in the following ways:

- Microsoft Windows XP System Restore returns your computer to an earlier operating state without affecting data files.
- Dell PC Restore by Symantec restores your hard drive to the operating state it was in when you purchased the computer. Dell PC Restore permanently deletes all data on the hard drive and removes any applications installed after you received the computer.



NOTE: Dell PC Restore is available only on computers purchased in certain regions.

Using Microsoft Windows XP System Restore

The Microsoft Windows XP operating system provides System Restore to allow you to return your computer to an earlier operating state (without affecting data files) if changes to the hardware, software, or other system settings have left the computer in an undesirable operating state. See the Windows Help and Support Center for information on using System Restore. To access help, see page 11.



NOTICE: Make regular backups of your data files. System Restore does not monitor your data files or recover them.



NOTE: The procedures in this document were written for the Windows default view, so they may not work if you set your Dell™ computer to the Windows Classic view.

Creating a Restore Point

- 1 Click the **Start** button and click **Help and Support**.
- 2 Click **System Restore**.
- 3 Follow the instructions on the screen.

Restoring the Computer to an Earlier Operating State

If problems occur after you install a device driver, use Device Driver Rollback (see page 48) to resolve the problem. If that is unsuccessful, then use System Restore.



NOTICE: Before you restore the computer to an earlier operating state, save and close any open files and exit any open programs. Do not alter, open, or delete any files or programs until the system restoration is complete.

- 1 Click the **Start** button, point to **All Programs**→**Accessories**→**System Tools**, and then click **System Restore**.
- 2 Ensure that **Restore my computer to an earlier time** is selected and click **Next**.
- 3 Click a calendar date to which you want to restore your computer.

The **Select a Restore Point** screen provides a calendar that allows you to see and select restore points. All calendar dates with available restore points appear in boldface type.

- 4 Select a restore point and click **Next**.

If a calendar date has only one restore point, then that restore point is automatically selected. If two or more restore points are available, click the restore point that you prefer.

- 5 Click **Next**.

The **Restoration Complete** screen appears after System Restore finishes collecting data and then the computer restarts.

- 6 After the computer restarts, click **OK**.

To change the restore point, you can either repeat the steps using a different restore point, or you can undo the restoration.

Undoing the Last System Restore

-  **NOTICE:** Before you undo the last system restore, save and close all open files and exit any open programs. Do not alter, open, or delete any files or programs until the system restoration is complete.
- 1 Click the **Start** button, point to **All Programs**→**Accessories**→**System Tools**, and then click **System Restore**.
 - 2 Click **Undo my last restoration** and click **Next**.

Enabling System Restore

If you reinstall Windows XP with less than 200 MB of free hard-disk space available, System Restore is automatically disabled. To see if System Restore is enabled:

- 1 Click the **Start** button and click **Control Panel**.
- 2 Click **Performance and Maintenance**.
- 3 Click **System**.
- 4 Click the **System Restore** tab.

Ensure that **Turn off System Restore** is unchecked.

Using Dell PC Restore by Symantec

-  **NOTE:** Dell PC Restore is available only on computers purchased in certain regions.

Use Dell PC Restore by Symantec only as the last method to restore your operating system. PC Restore restores your hard drive to the operating state it was in when you purchased the computer. Any programs or files added since you received your computer—including data files—are permanently deleted from the hard drive. Data files include documents, spreadsheets, e-mail messages, digital photos, music files, and so on. If possible, back up all data before using PC Restore.

-  **NOTICE:** Using PC Restore permanently deletes all data on the hard drive and removes any applications or drivers installed after you received your computer. If possible, back up the data before using PC Restore.

To use PC Restore:

- 1 Turn on the computer.
During the boot process, a blue bar with www.dell.com appears at the top of the screen.
- 2 Immediately upon seeing the blue bar, press <Ctrl><F11>.
If you do not press <Ctrl><F11> in time, let the computer finish restarting, and then restart the computer again.

-  **NOTICE:** If you do not want to proceed with PC Restore, click **Reboot** in the following step.
- 3 On the next screen that appears, click **Restore**.

- 4 On the next screen, click **Confirm**.

The restore process takes approximately 6–10 minutes to complete.

- 5 When prompted, click **Finish** to reboot the computer.



NOTE: Do not manually shut down the computer. Click **Finish** and let the computer completely reboot.

- 6 When prompted, click **Yes**.

The computer restarts. Because the computer is restored to its original operating state, the screens that appear, such as the End User License Agreement, are the same ones that appeared the first time the computer was turned on.

- 7 Click **Next**.

The **System Restore** screen appears and the computer restarts.

- 8 After the computer restarts, click **OK**.

Removing and Installing Parts

Before You Begin

This chapter provides procedures for removing and installing the components in your computer. Unless otherwise noted, each procedure assumes that the following conditions exist:

- You have performed the steps in "Turning Off Your Computer" on page 53 and "Before Working Inside Your Computer" on page 53.
- You have read the safety information in your Dell™ *Product Information Guide*.
- A component can be replaced or—if purchased separately—installed by performing the removal procedure in reverse order.

Recommended Tools

The procedures in this document may require the following tools:

- Small flat-blade screwdriver
- Phillips screwdriver

Turning Off Your Computer

 **NOTICE:** To avoid losing data, save and close any open files and exit any open programs before you turn off your computer.

- 1 Shut down the operating system:
 - a Save and close any open files, exit any open programs, click the **Start** button, and then click **Turn Off Computer**.
 - b In the **Turn off computer** window, click **Turn off**.
The computer turns off after the operating system shutdown process finishes.
- 2 Ensure that the computer and any attached devices are turned off. If your computer and attached devices did not automatically turn off when you shut down your operating system, press and hold the power button for 4 seconds.

Before Working Inside Your Computer

Use the following safety guidelines to help protect your computer from potential damage and to help ensure your own personal safety.

 **CAUTION:** Before you begin any of the procedures in this section, follow the safety instructions in the *Product Information Guide*.

 **CAUTION:** Handle components and cards with care. Do not touch the components or contacts on a card. Hold a card by its edges or by its metal mounting bracket. Hold a component such as a processor by its edges, not by its pins.

 **NOTICE:** Only a certified service technician should perform repairs on your computer. Damage due to servicing that is not authorized by Dell is not covered by your warranty.

 **NOTICE:** When you disconnect a cable, pull on its connector or on its strain-relief loop, not on the cable itself. Some cables have a connector with locking tabs; if you are disconnecting this type of cable, press in on the locking tabs before you disconnect the cable. As you pull connectors apart, keep them evenly aligned to avoid bending any connector pins. Also, before you connect a cable, ensure that both connectors are correctly oriented and aligned.

 **NOTICE:** To avoid damaging the computer, perform the following steps before you begin working inside the computer.

1 Turn off your computer (see page 53).

 **NOTICE:** To disconnect a network cable, first unplug the cable from your computer and then unplug it from the network wall jack.

2 Disconnect any telephone or network cables from the computer.

3 Disconnect your computer and all attached devices from their electrical outlets, and then press the power button to ground the system board.



 **CAUTION:** To guard against electrical shock, always unplug your computer from the electrical outlet before opening the cover.

4 Remove the computer cover (see page 59).

 **NOTICE:** Before touching anything inside your computer, ground yourself by touching an unpainted metal surface, such as the metal at the back of the computer. While you work, periodically touch an unpainted metal surface to dissipate any static electricity that could harm internal components.

Front and Back View of the Computer

Front View

-  **NOTE:** The front-panel door does not close when you are using certain Flash Media or IEEE 1394, USB, or headphone connectors.
-  **NOTE:** The front-panel door is removable; if you remove it or accidentally knock it off its hinges, it snaps back in place. For instructions on how to reattach the door, see page 59.

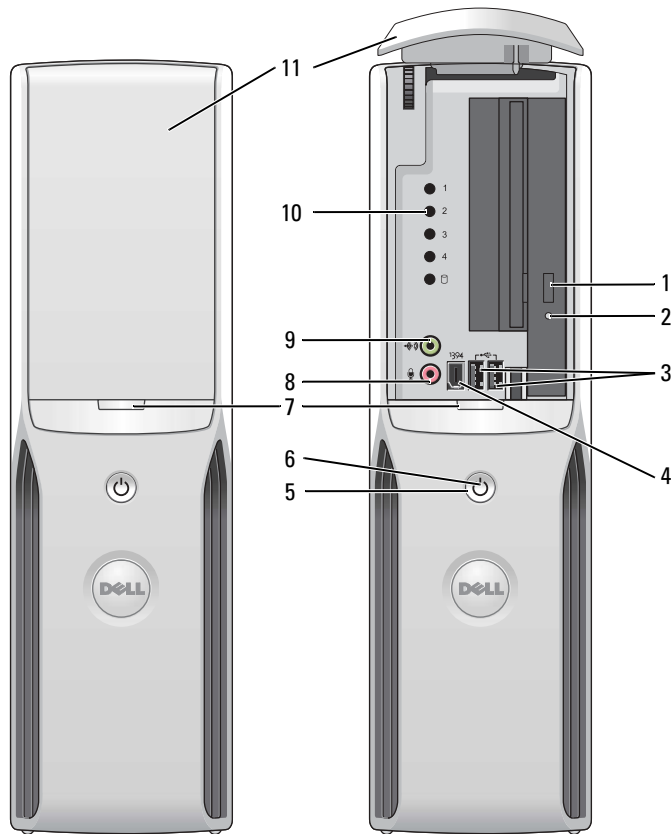

1	CD/DVD drive eject button	Press this button to eject a CD/DVD from the drive.
2	CD/DVD drive-activity light	The drive activity light is on when the computer reads data from the CD or DVD drive.
3	USB 2.0 connectors (2)	Use the front USB connectors for devices that you connect occasionally, such as joysticks or cameras (see "System Setup" on page 97 for more information on booting to a USB device). It is recommended that you use the back USB connectors for devices that typically remain connected, such as printers and keyboards.
4	IEEE 1394 connector	Attach high-speed serial multimedia devices, such as digital video cameras. It is recommended that you use the back IEEE 1394 connector for devices that typically remain connected, such as external hard drives and other storage devices.
5	power button	Press this button to turn on the computer.  NOTICE: To avoid losing data, do not use the power button to turn off the computer. Instead, perform an operating system shutdown.
6	power light	The power light illuminates and blinks or remains solid to indicate different states: <ul style="list-style-type: none"> • No light — The computer is turned off. • Steady green — The computer is in a normal operating state. • Blinking green — The computer is in a power-saving state. • Blinking or solid amber — See "Power Problems" on page 36.
7	front-panel door release button	Press this button to access the front-panel connectors.
8	microphone connector	Use the pink microphone connector to attach a personal computer microphone for voice or musical input into a sound or telephony program. On computers with a sound card, the microphone connector is on the card.
9	headphone connector	Use the green headphone connector to attach headphones and most kinds of speakers.
10	diagnostic lights	For more information on what each diagnostic light means, see "Diagnostic Lights" on page 43.
11	front-panel door	This panel covers the CD/DVD drive, the media card reader, and the optional floppy drive.

Back View

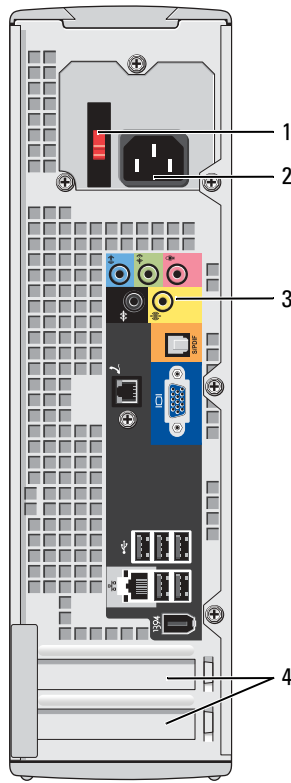

1	voltage selection switch (may not be available on certain computers)	See the safety instructions in the <i>Product Information Guide</i> for more information.
2	power connector	Insert the power cable.
3	back panel connectors	Plug serial, USB, and other devices into the appropriate connector.
4	card slots	Access connectors for any installed PCI and PCI Express cards.

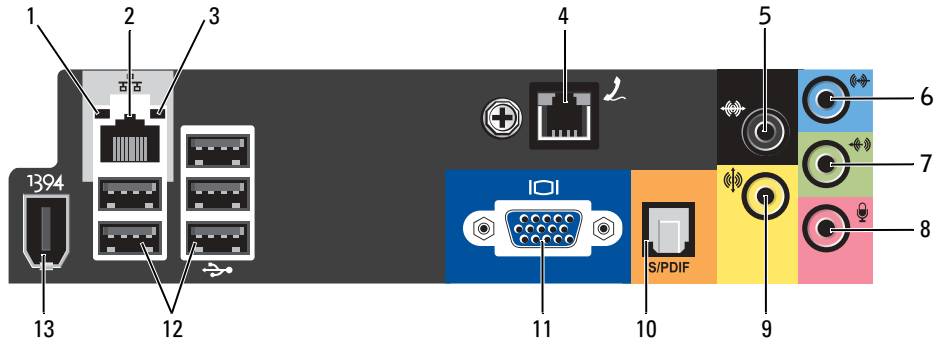

<p>1 link integrity light</p>	<ul style="list-style-type: none"> • Green — A good connection exists between a 10-Mbps network and the computer. • Orange — A good connection exists between a 100-Mbps network and the computer. • Off — The computer is not detecting a physical connection to the network.
<p>2 network adapter connector</p>	<p>To attach your computer to a network or broadband device, connect one end of a network cable to either a network jack or your network or broadband device. Connect the other end of the network cable to the network adapter connector on the back panel of your computer. A click indicates that the network cable has been securely attached.</p> <p>NOTE: Do not plug a telephone cable into the network connector.</p> <p>On computers with a network connector card, use the connector on the card.</p> <p>It is recommended that you use Category 5 wiring and connectors for your network. If you must use Category 3 wiring, force the network speed to 10 Mbps to ensure reliable operation.</p>
<p>3 network activity light</p>	<p>Flashes a yellow light when the computer is transmitting or receiving network data. A high volume of network traffic may make this light appear to be in a steady "on" state.</p>
<p>4 modem connector</p>	<p>Use the modem connector to connect your computer to the Internet.</p>
<p>5 surround sound connector</p>	<p>Use the black surround sound connector to attach multichannel-capable speakers.</p>
<p>6 line-in connector</p>	<p>Use the blue line-in connector to attach a record/playback device such as a cassette player, CD player, or VCR.</p> <p>On computers with a sound card, use the connector on the card.</p>

7	line-out connector	Use the green line-out connector to attach headphones and most speakers with integrated amplifiers. On computers with a sound card, use the connector on the card.
8	microphone/side surround sound connector	Use the pink and silver connector to attach a personal computer microphone for voice or musical input into a sound or telephony program. On computers with a sound card, the microphone connector is on the card.
9	center/LFE connector	LFE (Low Frequency Effects) Audio channel found in digital surround sound audio schemes that carries only low frequency information of 80 Hz and below. The LFE channel drives a subwoofer to provide extremely low bass extension. Systems not using subwoofers can shunt the LFE information to the main speakers in the surround sound set-up.
10	S/PDIF connector	This connector is used to transmit digital audio without going through an analog audio conversion process.
11	VGA connector	If your monitor has a VGA connector, plug it into the VGA connector on the computer.
12	USB 2.0 connectors (5)	Use the back USB connectors for devices that typically remain connected, such as printers and keyboards. It is recommended that you use the front USB connectors for devices that you connect occasionally, such as joysticks or cameras.
13	IEEE 1394 connector	Attach high-speed serial multimedia devices, such as digital video cameras.

Removing the Computer Cover

 **CAUTION:** Before you begin any of the procedures in this section, follow the safety instructions in the *Product Information Guide*.

- 1 Shut down the computer through the **Start** menu (see page 53).
- 2 Ensure that your computer and attached devices are turned off. If your computer and attached devices did not automatically turn off when you shut down your computer, turn them off now.

 **NOTICE:** To disconnect a network cable, first unplug the cable from your computer and then unplug it from the network wall jack.

- 3 Disconnect any telephone or telecommunication lines from the computer.
- 4 Disconnect your computer and all attached devices from their electrical outlets, and then press the power button to ground the system board.

 **CAUTION:** To guard against electrical shock, always unplug your computer from the electrical outlet before opening the cover.

 **NOTICE:** Ensure that sufficient space exists to support the removed cover—at least 30 cm (1 ft) of desk top space.

- ➔ **NOTICE:** Ensure that you are working on a level, protected surface to avoid scratching either the computer or the surface on which it is resting.
- 5 Lay your computer on its side with the computer cover facing up.
- 6 Pull back the cover latch release on the top panel.

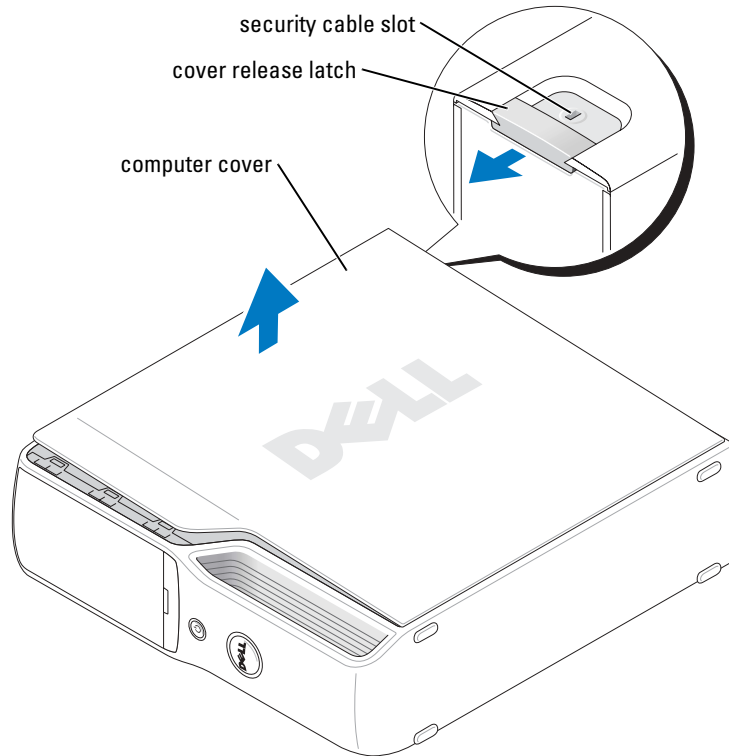

- 7 Locate the two hinge tabs on the bottom edge of the computer.
- 8 Grip the sides of the computer cover and pivot the cover up, using the bottom hinges as leverage points.
- 9 Release the cover from the hinge tabs and set it aside in a secure location.

Inside View of Your Computer

 **CAUTION:** Before you begin any of the procedures in this section, follow the safety instructions in the *Product Information Guide*.

 **CAUTION:** To guard against electrical shock, always unplug your computer from the electrical outlet before opening the cover.

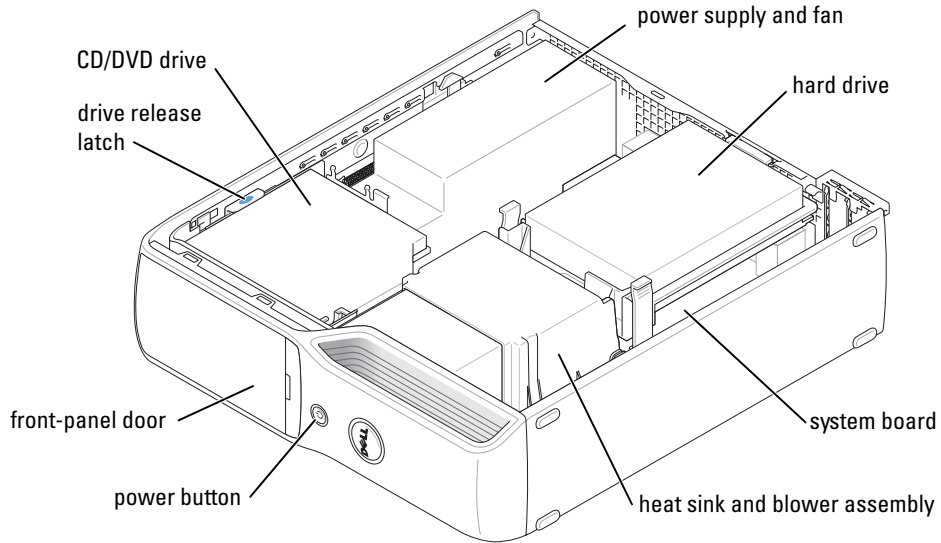

System Board Components

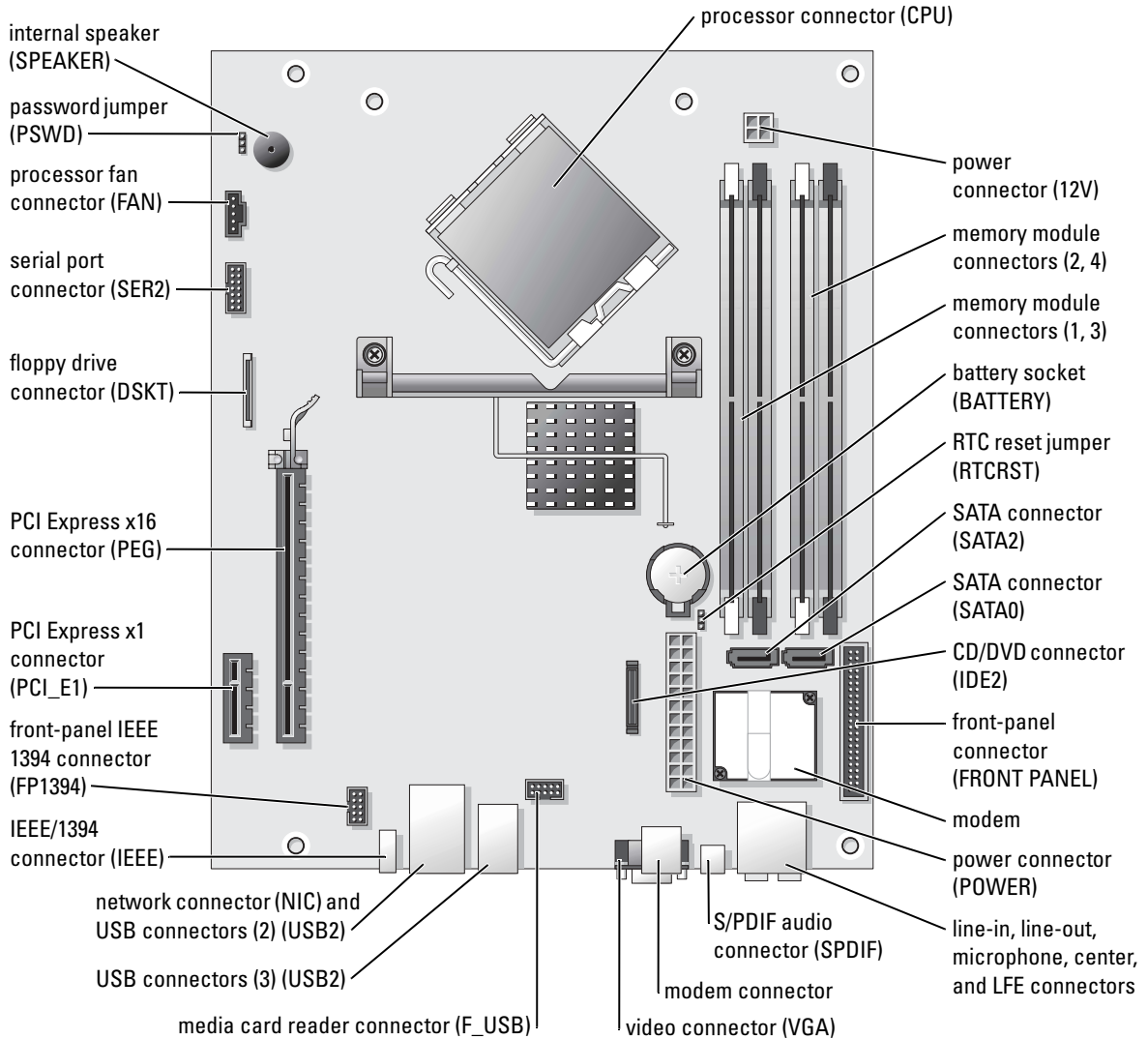

Memory

You can increase your computer memory by installing memory modules on the system board.

Your computer supports DDR2 memory.

 **NOTE:** Buffered memory is not supported on this computer.

DDR2 Memory Overview

DDR2 memory modules should be installed in *pairs of matched memory size, speed, and technology*. If the DDR2 memory modules are not installed in matched pairs, the computer will continue to operate, but with a slight reduction in performance. See the label on the module to determine the module's capacity.

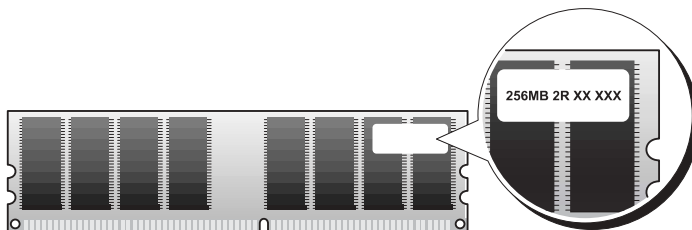

 **NOTE:** Always install DDR2 memory modules in the order indicated on the system board.

The recommended memory configurations are:

- A pair of matched memory modules installed in DIMM connectors 1 and 2 (white securing clips)
- or
- A pair of matched memory modules installed in DIMM connectors 1 and 2 and another matched pair installed in DIMM connectors 3 and 4 (black securing clips)

 **NOTICE:** Do not install ECC memory modules.

- If you install mixed pairs of DDR2 400-MHz (PC2-3200) and DDR2 533-MHz (PC2-4300) memory, the modules function at the speed of the slowest module installed.
- Be sure to install a single memory module in DIMM connector 1, the connector closest to the processor, before you install modules in the other connectors.

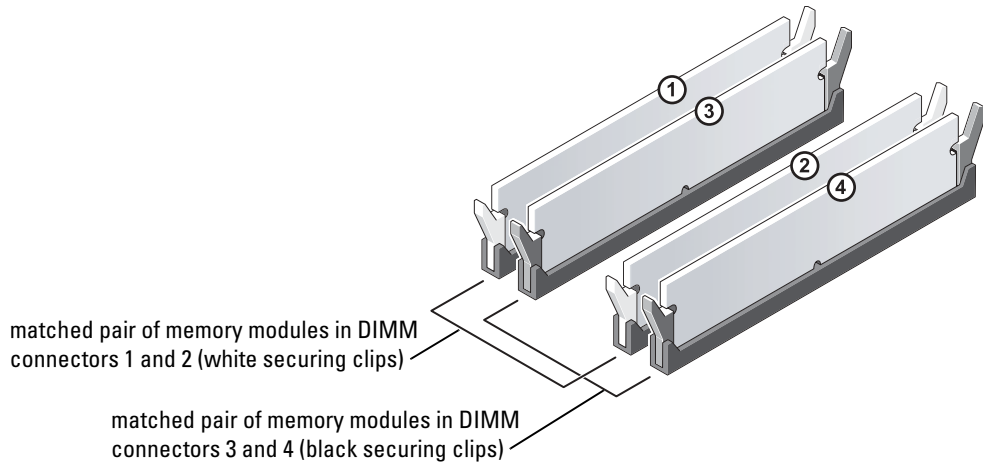

 **NOTE:** Memory purchased from Dell is covered under your computer warranty.

 **NOTICE:** If you remove your original memory modules from the computer during a memory upgrade, keep them separate from any new modules that you may have, even if you purchased the new modules from Dell. If possible, *do not* pair an original memory module with a new memory module. Otherwise, your computer may not start properly. You should install your original memory modules in pairs either in DIMM connectors 1 and 2 or DIMM connectors 3 and 4.

Addressing Memory With 4-GB Configurations

Your computer supports a maximum of 4 GB of memory when you use two 2-GB DIMMs. Current operating systems, such as Microsoft® Windows® XP, can only use a maximum of 4 GB of address space; however, the amount of memory available to the operating system is less than 4 GB. Certain components within the computer require address space in the 4-GB range. Any address space reserved for these components cannot be used by computer memory.

Installing Memory

 **CAUTION:** Before you begin any of the procedures in this section, follow the safety instructions located in the *Product Information Guide*.

 **NOTICE:** To prevent static damage to components inside your computer, discharge static electricity from your body before you touch any of your computer's electronic components. You can do so by touching an unpainted metal surface on the computer chassis.

- 1 Follow the procedures in "Before You Begin" on page 53.
- 2 Lay the computer on its side so that the system board is on the bottom of the inside of the computer.
- 3 Press out the securing clip at each end of the memory module connector.

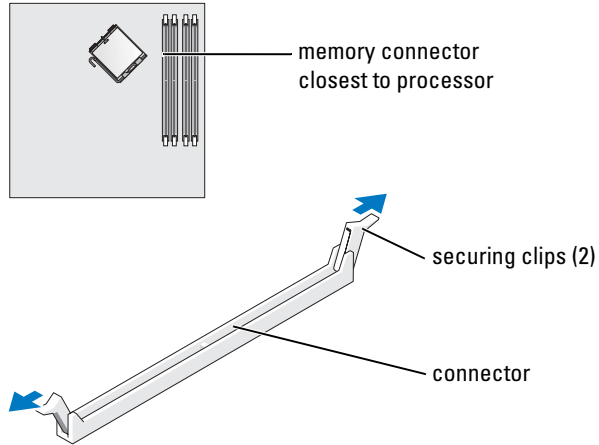

- 4 Align the notch on the bottom of the module with the crossbar in the connector.

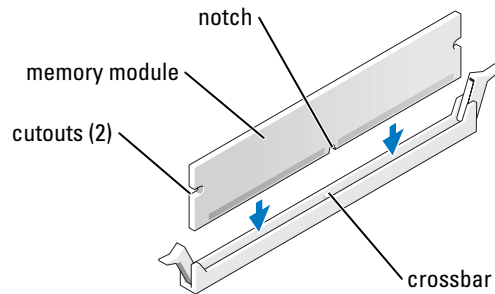

NOTICE: To avoid damage to the memory module, press the module straight down into the connector while you apply equal force to each end of the module.

- 5 Insert the module into the connector until the module snaps into position.

If you insert the module correctly, the securing clips snap into the cutouts at each end of the module.

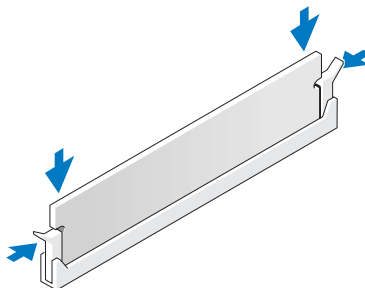

- 6 Replace the computer cover.
-  **NOTICE:** To connect a network cable, first plug the cable into the network device and then plug it into the computer.
- 7 Connect your computer and devices to electrical outlets, and turn them on.
- 8 Right-click the My Computer icon and click Properties.
- 9 Click the General tab.
- 10 To verify that the memory is installed correctly, check the amount of memory (RAM) listed.

Removing Memory



CAUTION: Before you begin any of the procedures in this section, follow the safety instructions located in the *Product Information Guide*.



NOTICE: To prevent static damage to components inside your computer, discharge static electricity from your body before you touch any of your computer's electronic components. You can do so by touching an unpainted metal surface on the computer chassis.

- 1 Follow the procedures in "Before You Begin" on page 53.
- 2 Press out the securing clip at each end of the memory module connector.
- 3 Grasp the module and pull up.

If the module is difficult to remove, gently ease the module back and forth to remove it from the connector.

Cards



CAUTION: Before you begin any of the procedures in this section, follow the safety instructions located in the *Product Information Guide*.



NOTICE: To prevent static damage to components inside your computer, discharge static electricity from your body before you touch any of your computer's electronic components. You can do so by touching an unpainted metal surface on the computer chassis.

Your Dell™ computer provides the following slots for PCI Express cards:

- One PCI Express x16 card slot
- One PCI Express x1 card slot



NOTE: The slots for the PCI Express x16 and PCI Express x1 cards are half-height slots.

PCI Express Cards

Your computer supports one PCI Express x16 card and one PCI Express x1 card.

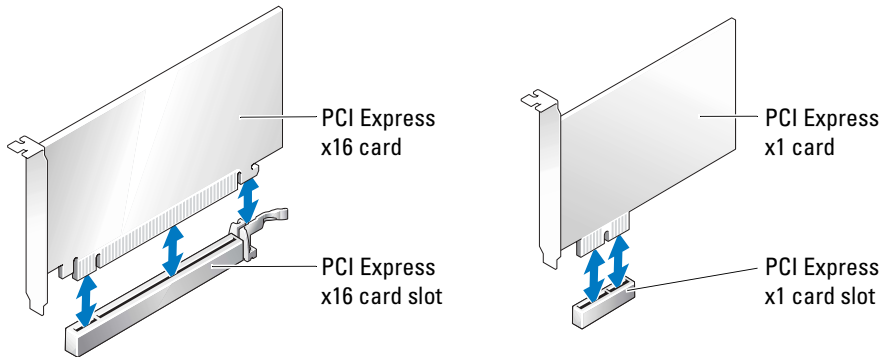

If you are installing or replacing a PCI Express card, follow the procedures in the next section. If you are removing but not replacing a card, see "Removing a PCI Express Card" on page 70.

If you are replacing a card, remove the current driver for the card from the operating system.

Installing a PCI Express Card

- 1 Follow the procedures in "Before You Begin" on page 53.
- 2 Gently push the release tab on the card retention door from the inside to pivot the door open. Because the door is attached, it will remain in the open position.
- 3 If you are installing a new card, remove the filler bracket to create a card-slot opening. Then continue with step 5.
- 4 If you are replacing a card that is already installed in the computer, remove the card.
If necessary, disconnect any cables connected to the card. Grasp the card by its top corners, and ease it out of its connector.
- 5 Prepare the card for installation.

See the documentation that came with the card for information on configuring the card, making internal connections, or otherwise customizing it for your computer.



CAUTION: Some network adapters automatically start the computer when they are connected to a network. To guard against electrical shock, be sure to unplug your computer from its electrical outlet before installing any cards.

- 6 Place the card in the connector and press down firmly. Ensure that the card is fully seated in the slot.

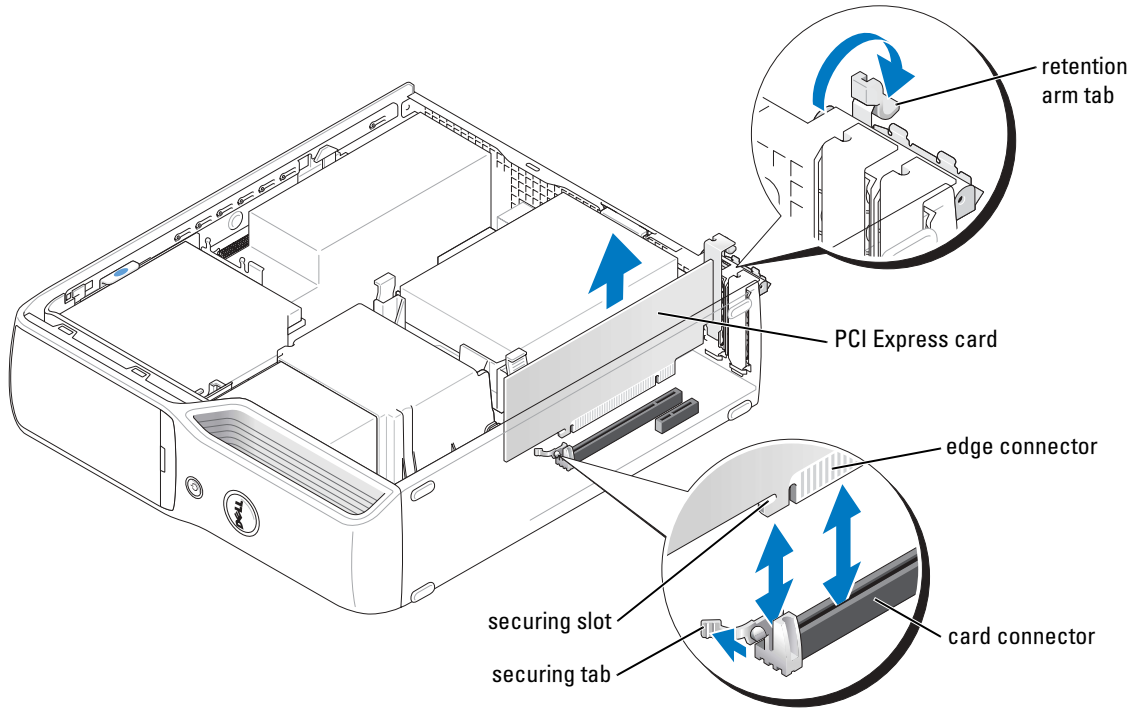

- 7 Prepare the card for installation.

See the documentation that came with the card for information on configuring the card, making internal connections, or otherwise customizing it for your computer.



CAUTION: Some network adapters automatically start the computer when they are connected to a network. To guard against electrical shock, be sure to unplug your computer from its electrical outlet before installing any cards.

- 8 If you are installing the card into the x16 card connector, position the card so the securing slot is aligned with the securing tab, and gently pull the securing tab.
- 9 Place the card in the connector and press down firmly. Ensure that the card is fully seated in the slot.

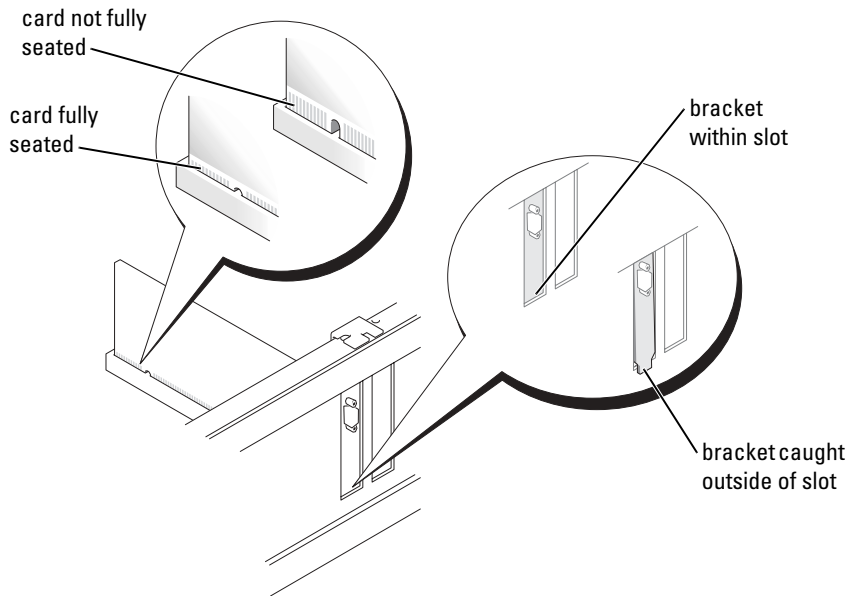

10 Before you close the card retention door, ensure that:

- The tops of all cards and filler brackets are flush with the alignment bar.
- The notch in the top of the card or filler bracket fits around the alignment guide.

- 11** Close the card retention door by snapping it into place to secure the card(s).

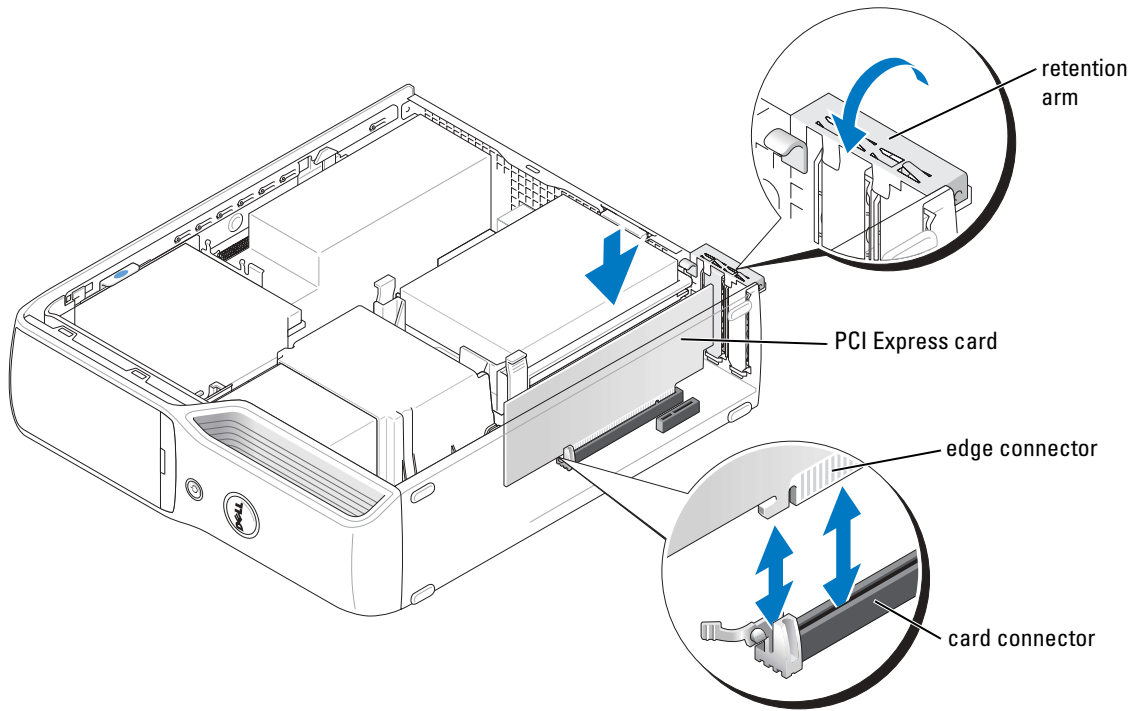

- NOTICE:** Do not route card cables over or behind the cards. Cables routed over the cards can prevent the computer cover from closing properly or cause damage to the equipment.
- 12** Connect any cables that should be attached to the card.
See the documentation that came with the card for information about the card's cable connections.
- NOTICE:** To connect a network cable, first plug the cable into the network device and then plug it into the computer.
- 13** Replace the computer cover, reconnect the computer and devices to electrical outlets, and then turn them on.
- 14** Install any drivers required for the card as described in the card documentation.

Removing a PCI Express Card

- 1 Follow the procedures in "Before You Begin" on page 53.
- 2 If necessary, disconnect any cables connected to the card.
- 3 Gently pull back the securing tab, grasp the card by its top corners, and then ease it out of its connector.

- 4 If you are removing the card permanently, install a filler bracket in the empty card-slot opening.

If you need a filler bracket, contact Dell (see page 108).

 **NOTE:** Installing filler brackets over empty card-slot openings is necessary to maintain FCC certification of the computer. The brackets also keep dust and dirt out of your computer.

- 5 Secure the card(s) in the computer.

 **NOTICE:** To connect a network cable, first plug the cable into the network device and then plug it into the computer.

- 6 Replace the computer cover, reconnect the computer and devices to electrical outlets, and then turn them on.

- 7 Remove the card's driver from the operating system.

- 8 Install any drivers required for the card as described in the card documentation.

Drives

Your computer supports a combination of these devices:

- One serial ATA drive
- One FlexBay drive (optional floppy drive or media card reader)
- One CD or DVD drive

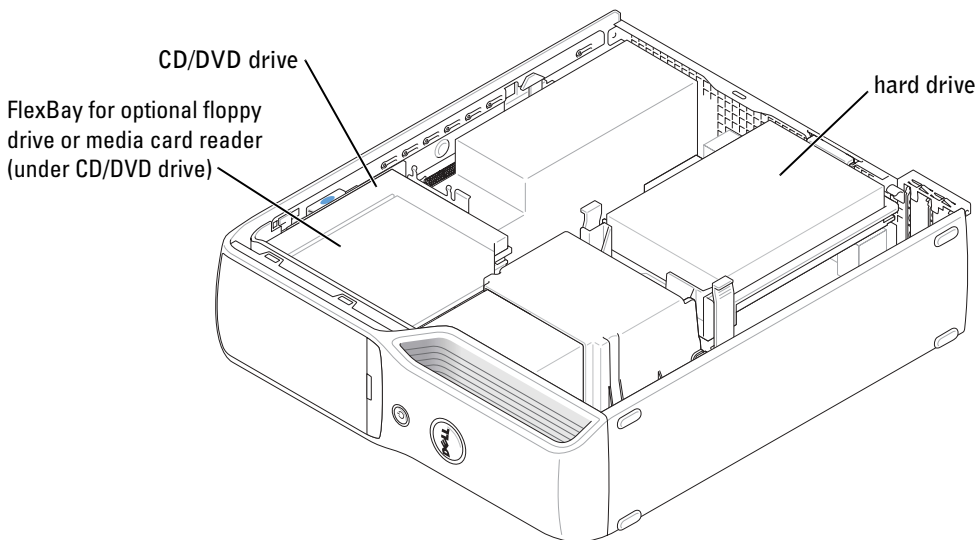

Connect CD/DVD drives to the connector labeled "IDE" on the system board. Serial ATA hard drives should be connected to the connectors labeled "SATA0" or "SATA2" on the system board.

Connecting Drive Cables

When you install a drive, you connect two cables—a DC power cable and a data cable—to the back of the drive and to the system board.

Drive Interface Connectors

Most interface connectors are keyed for correct insertion; that is, a notch or a missing pin on one connector matches a tab or a filled-in hole on the other connector. Serial ATA cables go to the pin-1 end of the connector. The pin-1 end of a connector on a board or a card is usually indicated by a silk-screened “1” printed directly on the board or card.

NOTICE: When you connect an IDE interface cable, do not place the colored stripe away from pin 1 of the connector. Reversing the cable prevents the drive from operating and could damage the controller, the drive, or both.

Serial ATA Connector

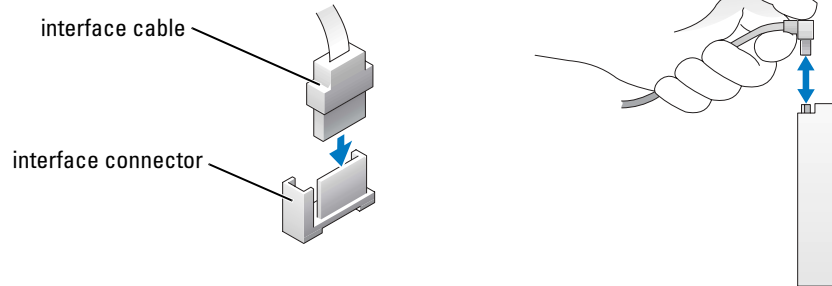

Power Cable Connector

To connect a drive using the power cable, locate the power input connector on the system board.

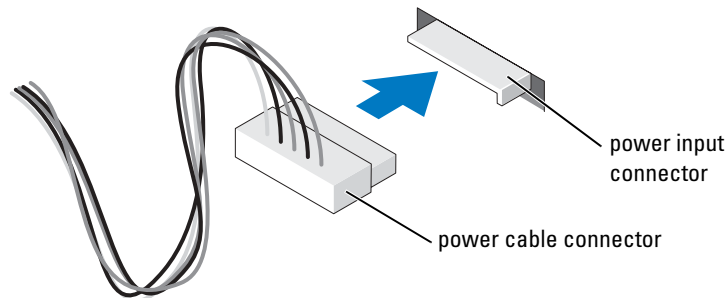

Connecting and Disconnecting Drive Cables

When removing an IDE drive data cable, grasp the colored pull-tab and pull until the connector detaches.

When connecting and disconnecting a serial ATA data cable, hold the cable by the black connector at each end.

Like IDE connectors, the serial ATA interface connectors are keyed for correct insertion; that is, a notch or a missing pin on one connector matches a tab or a filled-in hole on the other connector.

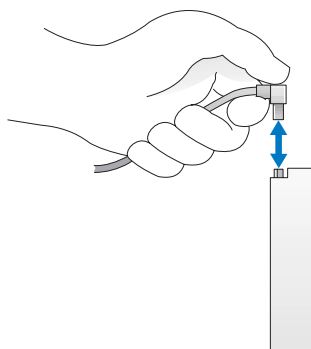

Hard Drive

⚠ CAUTION: Before you begin any of the procedures in this section, follow the safety instructions located in the *Product Information Guide*.

⚠ CAUTION: To guard against electrical shock, always unplug your computer from the electrical outlet before removing the cover.

🔄 NOTICE: To avoid damage to the drive, do not set it on a hard surface. Instead, set the drive on a surface, such as a foam pad, that will sufficiently cushion it.

🔄 NOTICE: If you are replacing a hard drive that contains data you want to keep, back up your files before you begin this procedure.

Check the documentation for the drive to verify that it is configured for your computer.

Removing a Hard Drive

- 1 Follow the procedures in "Before You Begin" on page 53."
- 2 Lay the computer on its side so that the system board is on the bottom of the inside of the computer.
- 3 Remove the computer cover (see page 59).

- 4 Press in on the blue tabs on each side of the drive and slide the drive up and out of the computer.

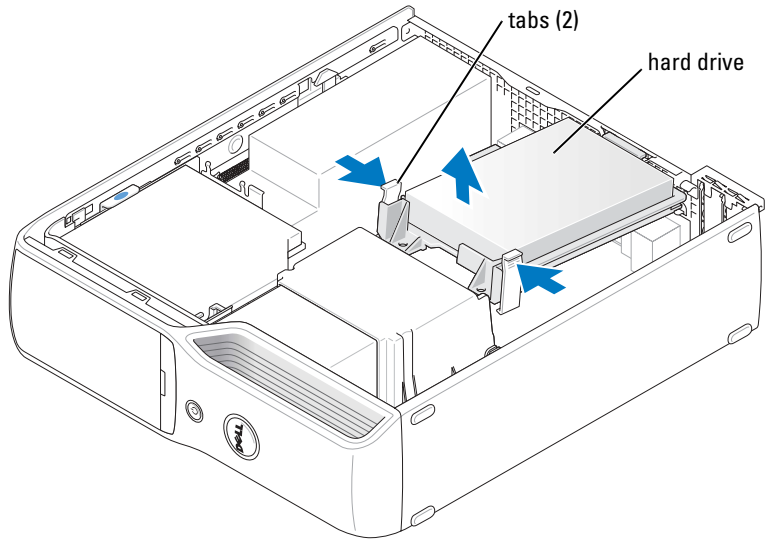

- 5 Disconnect the power and hard-drive cable from the drive.

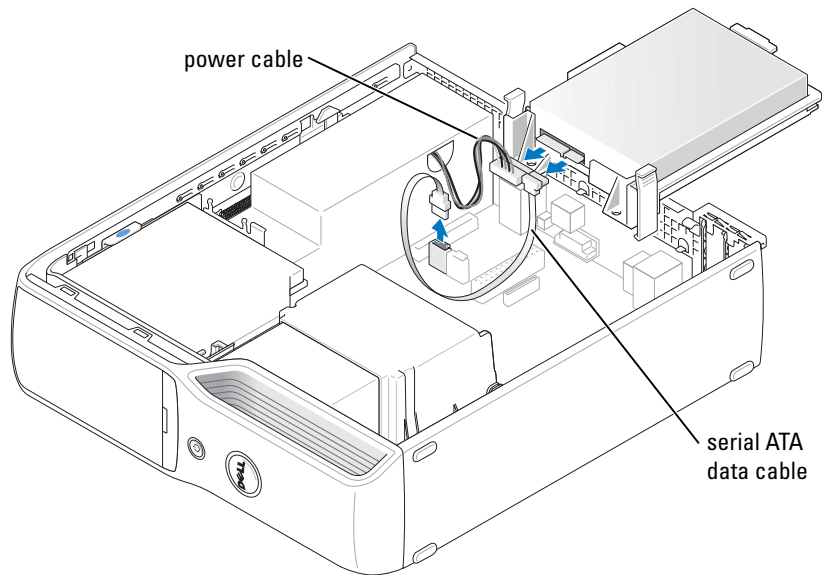

Installing a Hard Drive

- 1 Unpack the replacement hard drive, and prepare it for installation.
- 2 Check the documentation for the drive to verify that it is configured for your computer.

 **NOTE:** If your replacement hard drive does not have the plastic guide bracket attached, remove the bracket from the old drive by unsnapping it from the drive. Snap the bracket onto the new drive.

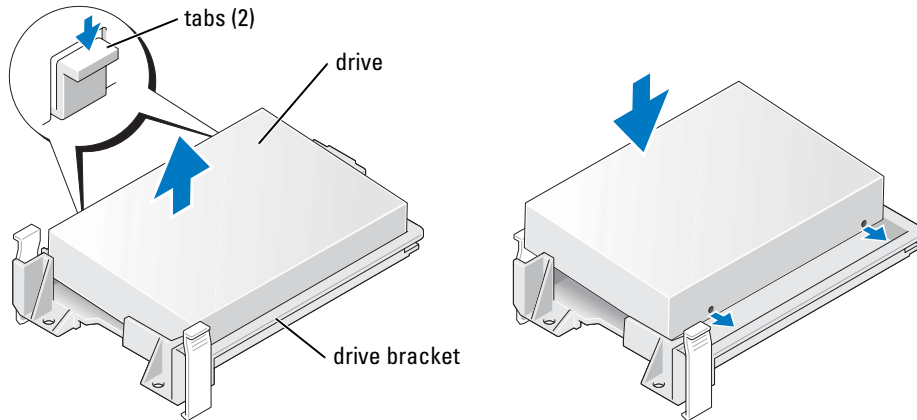

- 3 Connect the power and hard-drive cables to the drive.

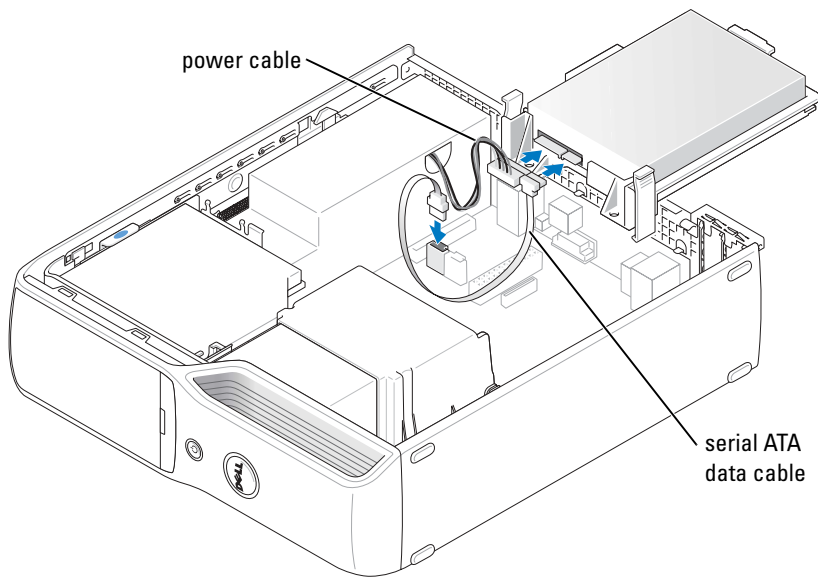

- 4 Check all connectors to be certain that they are properly cabled and firmly seated.

- 5 Gently slide the drive into place until you hear a click or feel the drive securely installed.

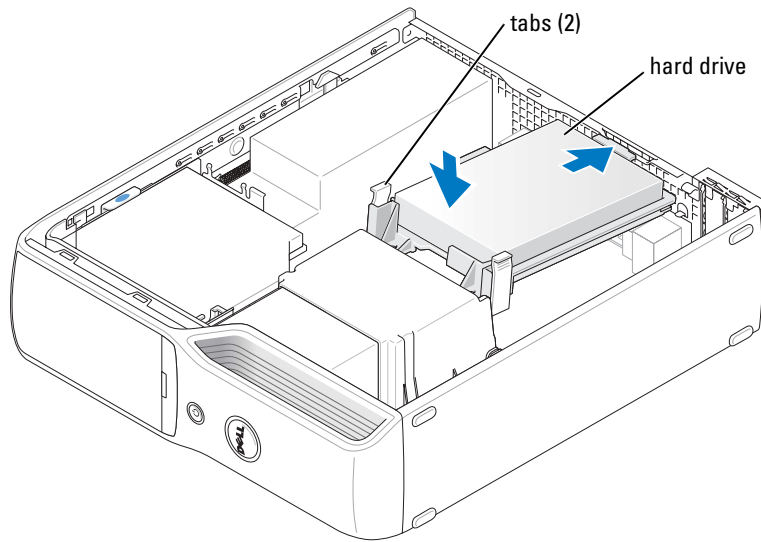

- 6 Replace the computer cover (page 91).

NOTICE: To connect a network cable, first plug the cable into the network wall jack and then plug it into the computer.

- 7 Connect your computer and devices to electrical outlets, and turn them on.

See the documentation that came with the drive for instructions on installing any software required for drive operation.

CD/DVD Drive



CAUTION: Before you begin any of the procedures in this section, follow the safety instructions in the *Product Information Guide*.



CAUTION: To guard against electrical shock, always unplug your computer from the electrical outlet before opening the cover.

Removing a CD/DVD Drive

- 1 Follow the procedures in "Before You Begin" on page 53.



NOTICE: Do not pull the drive out of the computer by the drive cables. Doing so may cause damage to cables and the cable connectors.

- 2 Lay the computer on its side so that the system board is on the bottom of the inside of the computer.
- 3 Remove the computer cover (see page 59).

- 4 Pull up on the drive release latch and slide the drive towards the back of the computer. Then, lift up to remove the drive from the computer.

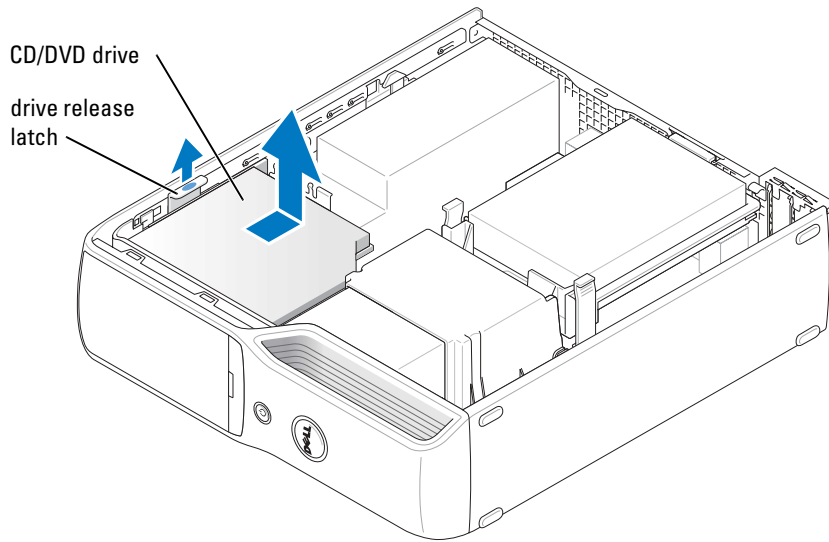

- 5 Disconnect the power and CD/DVD drive cables from the back of the drive.

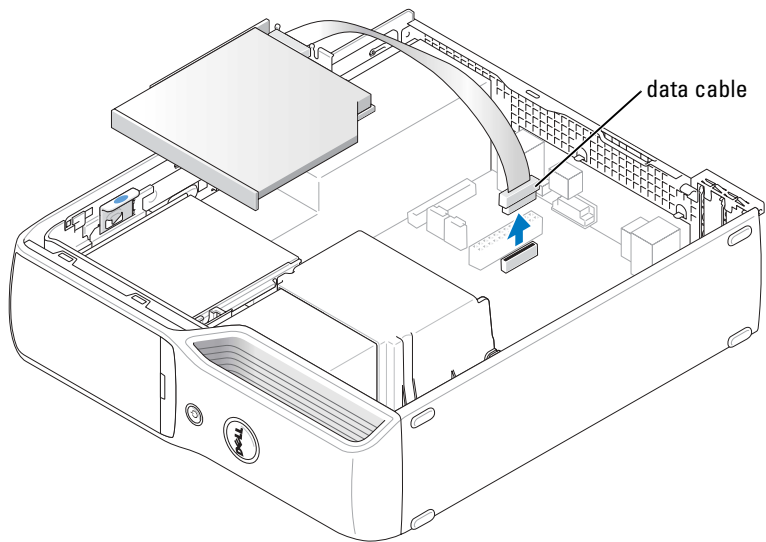

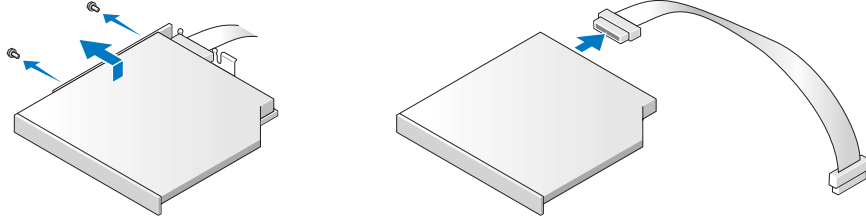

Installing a CD/DVD Drive

- 1 Unpack the drive and prepare it for installation.
Check the documentation that accompanied the drive to verify that the drive is configured for your computer. If you are installing an IDE drive, configure the drive for the cable select setting.
- 2 Connect the power and CD/DVD drive cables to the drive.

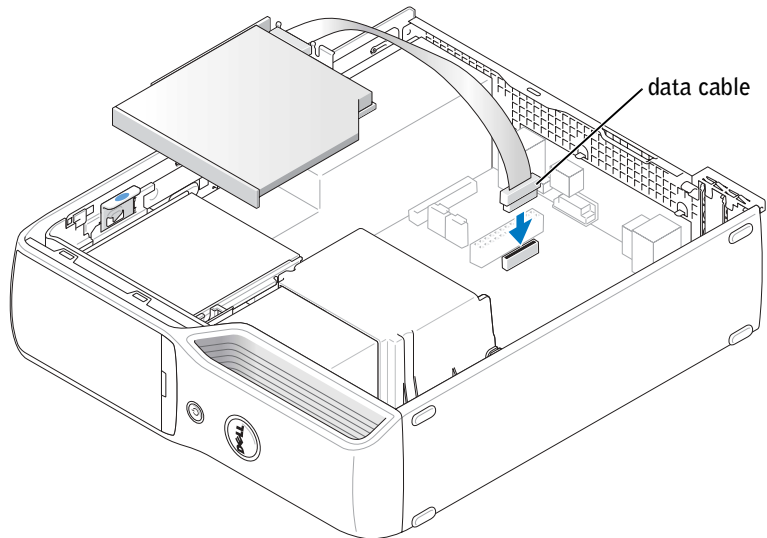
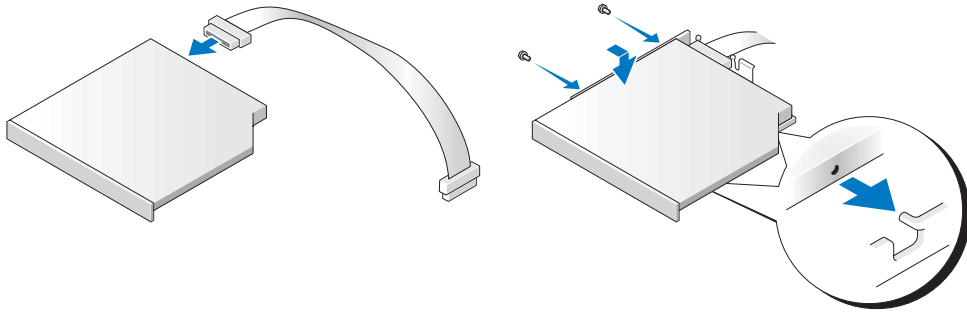

- 3 Gently slide the drive into place until you hear a click or feel the drive securely installed.

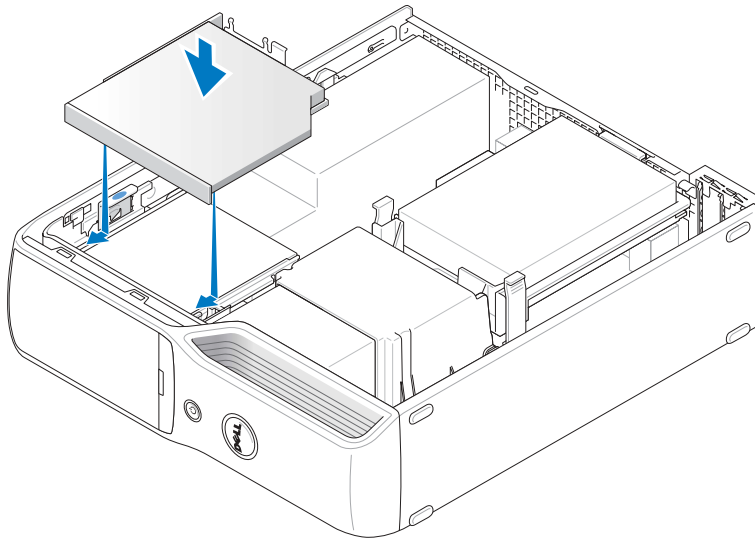

- 4 Check all cable connections, and fold cables out of the way to provide airflow for the fan and cooling vents.
- 5 Replace the computer cover.
- 6 Connect your computer and devices to their electrical outlets, and turn them on.
- 7 See the documentation that came with the drive for instructions on installing any software required for drive operation.
- 8 Enter system setup (see page 97) and select the appropriate **Drive** option.
Verify that your computer works correctly by running the Dell Diagnostics (see page 43).

Media Card Reader

For information on using the media card reader, see "Using a Media Card Reader (Optional)" on page 14.



CAUTION: Before you begin any of the procedures in this section, follow the safety instructions located in the *Product Information Guide*.



NOTICE: To prevent static damage to components inside your computer, discharge static electricity from your body before you touch any of your computer's electronic components. You can do so by touching an unpainted metal surface on the computer chassis.

Removing a Media Card Reader

- 1 Follow the procedures in "Before You Begin" on page 53."
- 2 Lay the computer on its side so that the system board is on the bottom of the inside of the computer.
- 3 Remove the computer cover (see page 59).
- 4 Remove the CD/DVD drive (see page 76).
- 5 Disconnect the data cable on the back of the media card reader from the front-panel connector on the system board.

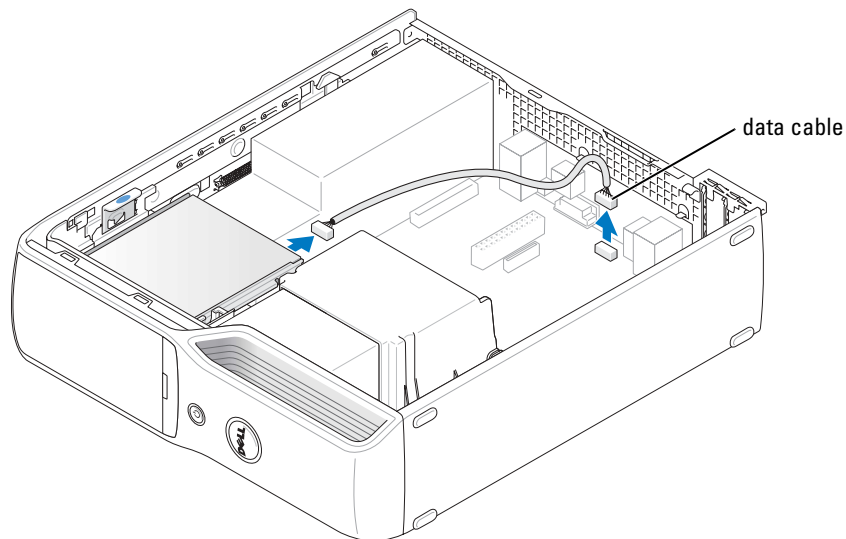

- 6 Pull up on the drive release latch and slide the media card reader towards the back of the computer. Then, lift up to remove the drive from the computer.

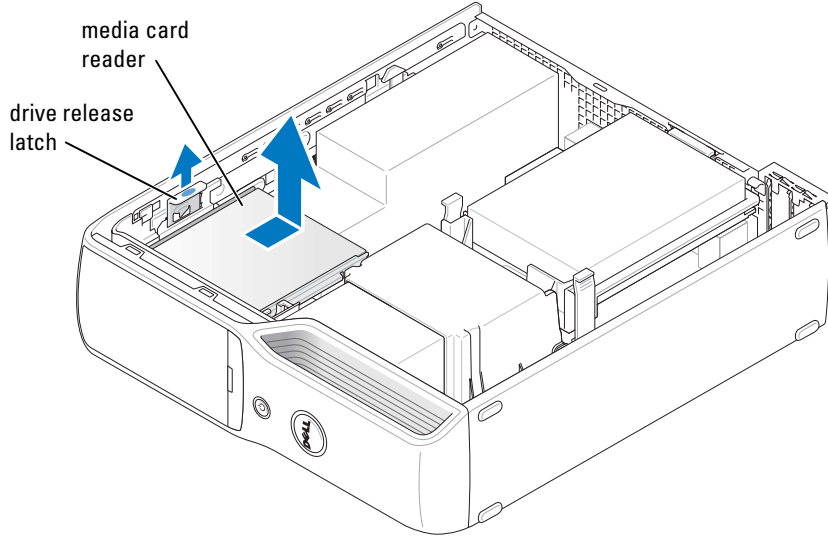

Installing a Media Card Reader

- 1 Follow the procedures in "Before You Begin" on page 53.
- 2 Lay the computer on its side so that the system board is on the bottom of the inside of the computer.
- 3 Remove the computer cover (see page 59).
- 4 Remove the media card reader from its packaging and ensure all the screws are included.

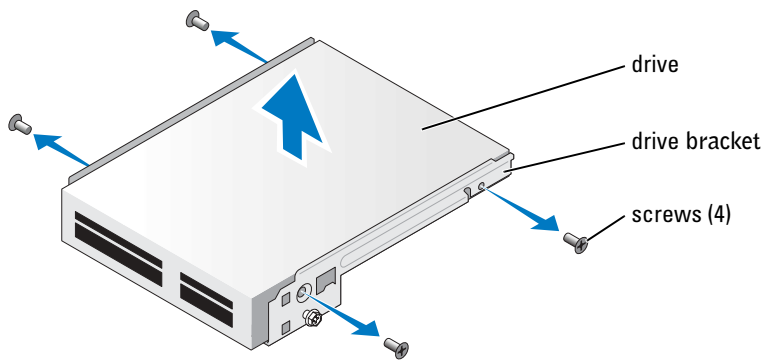

- 5 Gently slide the drive into place until you hear a click or feel the drive securely installed.

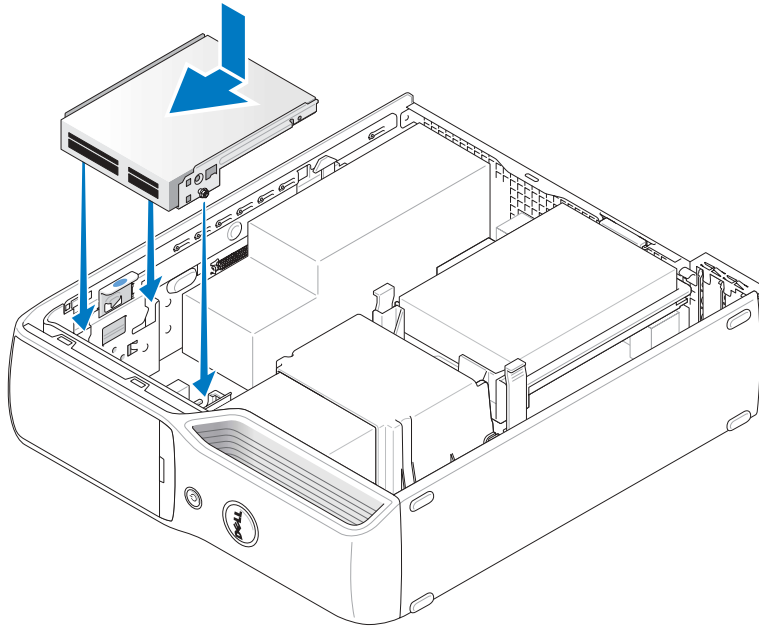

- 6 Reconnect the data cable on the back of the media card reader to the front-panel connector on the system board.

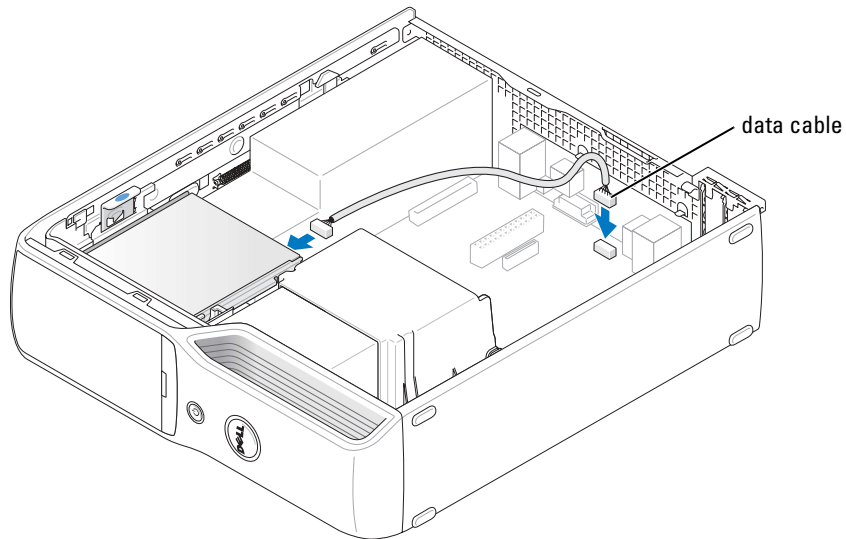

- 7 Replace the CD/DVD drive (see page 77).
- 8 Replace the computer cover (see page 91).
-  **NOTICE:** To connect a network cable, first plug the cable in to the network device and then plug it in to the computer.
- 9 Connect your computer and devices to their electrical outlets, and turn them on.
See the documentation that came with the drive for instructions on installing any software required for drive operation.
- 10 Enter system setup (see page 97) and select the appropriate **Drive** option.
- 11 Verify that your computer works correctly by running the Dell Diagnostics (see page 43).

Floppy Drive (Optional)



CAUTION: Before you begin any of the procedures in this section, follow the safety instructions located in the *Product Information Guide*.



CAUTION: To guard against electrical shock, always unplug your computer from the electrical outlet before removing the cover.

Removing a Floppy Drive

- 1 Follow the procedures in "Before You Begin" on page 53.
- 2 Lay the computer on its side so that the system board is on the bottom of the inside of the computer.
- 3 Remove the computer cover (see page 59).
- 4 Remove the CD/DVD drive (see page 76).
- 5 Pull up on the drive release latch and slide the floppy drive towards the back of the computer. Then, lift up to remove the drive from the computer.

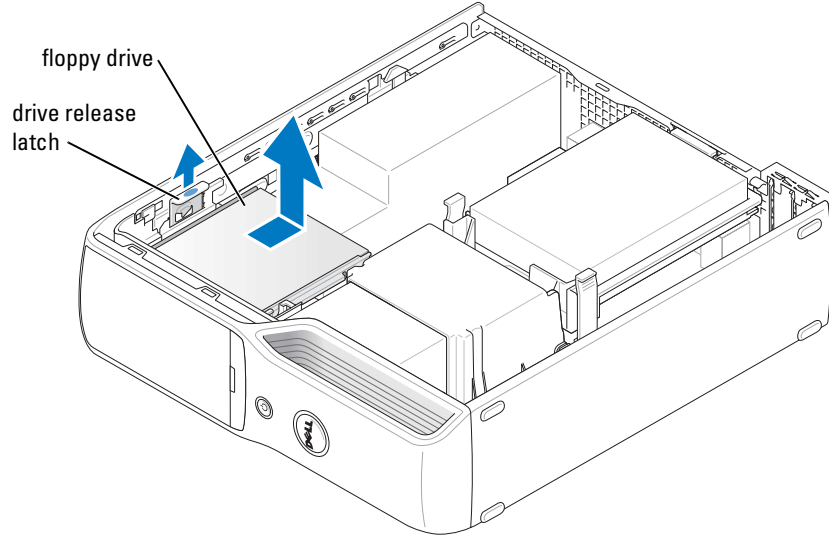

6 Disconnect the power and data cables from the back of the floppy drive.

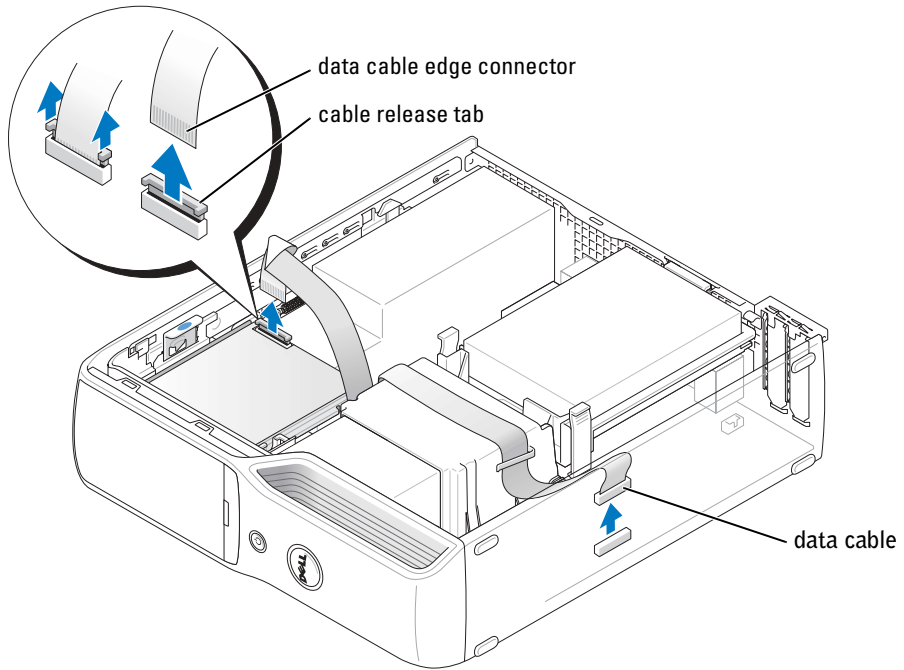

Installing a Floppy Drive

 **NOTE:** In the event the replacement or new floppy drive does not have the shoulder screws, use the screws located within the drive panel insert.

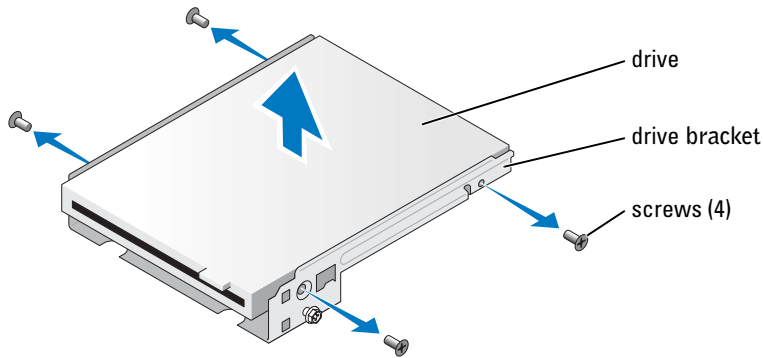

- 1 Follow the procedures in "Before You Begin" on page 53.
- 2 Lay the computer on its side so that the system board is on the bottom of the inside of the computer.
- 3 Remove the computer cover (see page 59).
- 4 Gently slide the drive into place until you hear a click or feel the drive securely installed.

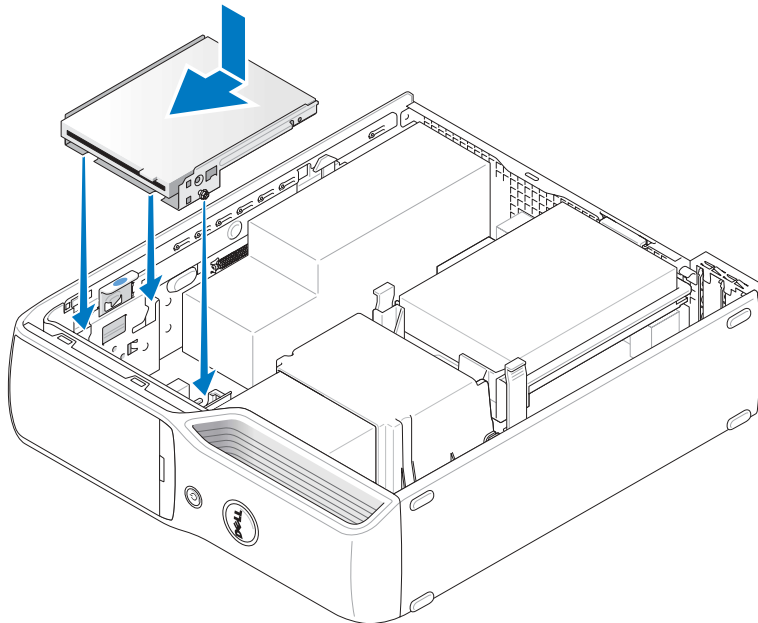

- 5 Attach the power and data cables to the floppy drive.

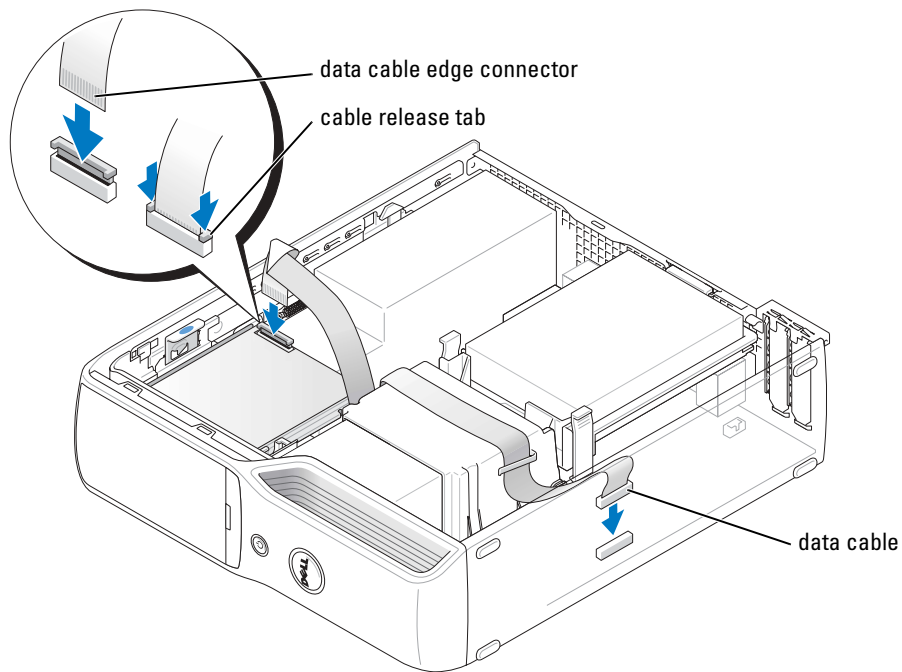

- 6 Check all cable connections, and fold cables out of the way to provide airflow for the fan and cooling vents.
- 7 Replace the CD/DVD drive (see page 77).
- 8 Replace the computer cover (see page 91).
- ➡ **NOTICE:** To connect a network cable, first plug the cable in to the network device and then plug it in to the computer.
- 9 Connect your computer and devices to their electrical outlets, and turn them on.
See the documentation that came with the drive for instructions on installing any software required for drive operation.
- 10 Enter system setup (see page 97) and select the appropriate **Diskette Drive** option.
- 11 Verify that your computer works correctly by running the Dell Diagnostics (see page 43).

Modem

 **CAUTION:** Before you begin any of the procedures in this section, follow the safety instructions in the *Product Information Guide*.

 **NOTICE:** Before you remove or install the modem, make sure to disconnect all telephone and network cables from your computer.

 **NOTICE:** To prevent static damage to components inside your computer, discharge static electricity from your body before you touch any of your computer's electronic components. You can do so by touching an unpainted metal surface on the computer chassis.

Replacing the Modem

- 1 Follow the procedures in "Before You Begin" on page 53.
- 2 Remove the computer cover (see page 59).

 **NOTE:** For easier access to the modem, it may be necessary to remove the power cable from the power supply.

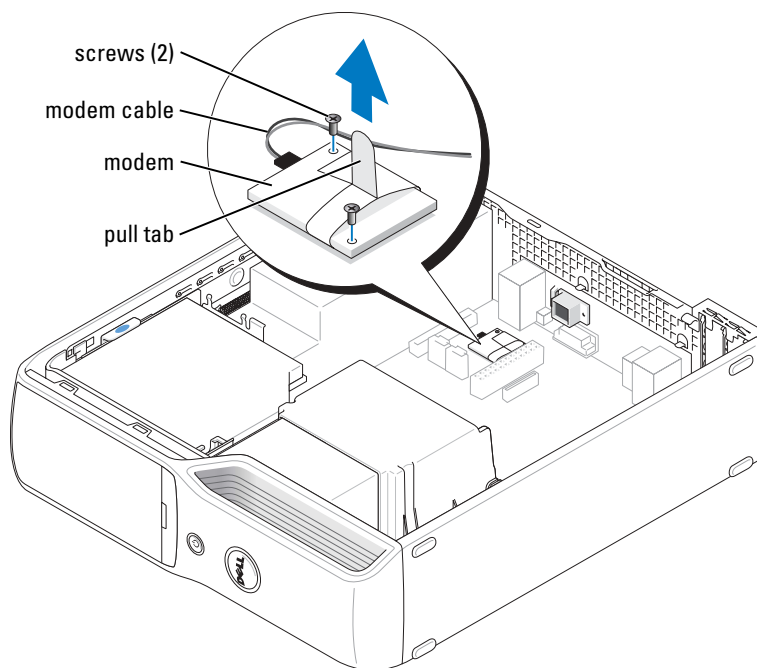

- 3 Remove the existing modem:
 - a Disconnect the modem cable from the modem.
 - b Use a small Phillips screwdriver to remove the two screws securing the modem to the system board, and set the screws aside.
 - c Pull straight up on the attached pull-tab to lift the modem out of its connector on the system board.



NOTICE: The connectors are keyed to ensure correct insertion. If you feel resistance, check the connectors and realign the card.

- 4 Install the new modem:
 - a Align the modem with the screw holes and press the modem into the connector on the system board.
 - b Use a Phillips screwdriver to replace and tighten the two screws that secure the modem to the system board.
 - c Connect the modem cable to the modem.
- 5 Replace the computer cover (see page 91).

Replacing the External Modem Connector

- 1 Follow the procedures in "Before You Begin" on page 53.
- 2 Remove the computer cover (see page 59).
- 3 Remove the modem cable from the modem.
- 4 Remove the external modem connector:
 - a Remove the screw that secures the external modem connector.
 - b Slide the external modem connector away from the slot that holds the modem connector in place.
 - c Lift the modem cable and connector from the computer.

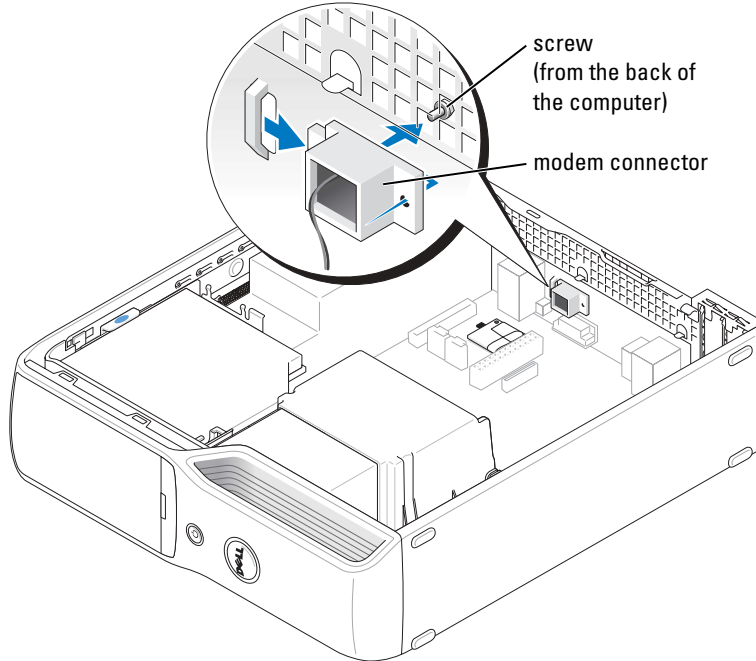

- 5 To install a new modem cable and external modem connector:
 - a Align the external connector with the slot on the back on the computer.
 - b Replace the screw that secures the external modem connector in place.
 - c Carefully route the cable wire and re-connect the modem cable to the modem.
- 6 Replace the computer cover (see page 91).

Battery



CAUTION: Before you begin any of the procedures in this section, follow the safety instructions located in the *Product Information Guide*.



NOTICE: To prevent static damage to components inside your computer, discharge static electricity from your body before you touch any of your computer's electronic components. You can do so by touching an unpainted metal surface on the computer chassis.

A coin-cell battery maintains computer configuration, date, and time information. The battery can last several years. If you have to repeatedly reset time and date information after turning on the computer, replace the battery.



CAUTION: A new battery can explode if it is incorrectly installed. Replace the battery only with the same or equivalent type recommended by the manufacturer. Discard used batteries according to the manufacturer's instructions.

Replacing the Battery

NOTE: For information regarding the type of coin-cell battery, see "Power" on page 96.

- 1 Record all the screens in system setup (see page 97) so that you can restore the correct settings in step 9.
- 2 Follow the procedures in "Before You Begin" on page 53.
- 3 Remove the computer cover (see page 59).
- 4 Locate the battery socket (see page 62).

NOTE: If you pry the battery out of its socket with a blunt object, be careful not to touch the system board with the object. Ensure that the object is inserted between the battery and the socket before you attempt to pry out the battery. Otherwise, you may damage the system board by prying off the socket or by breaking circuit traces on the system board.

- 5 Remove the system battery.
 - a Support the battery connector by pressing down firmly on the positive side of the connector.
 - b While supporting the battery connector, press the battery toward the positive side of the connector and pry it out of the securing tabs at the negative side of the connector.

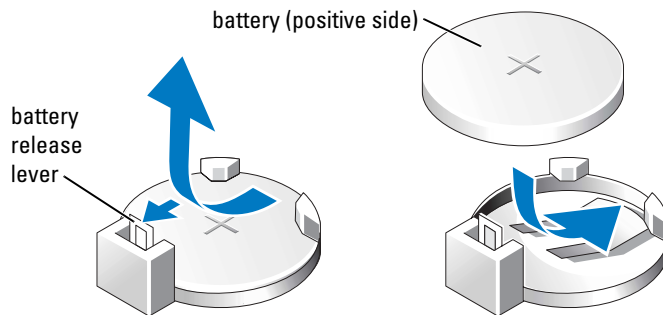

NOTE: To avoid damage to the battery connector, you must firmly support the connector while installing or removing a battery.

- 6 Install the new system battery.
 - a Support the battery connector by pressing down firmly on the positive side of the connector.
 - b Hold the battery with the "+" facing up, and slide it under the securing tabs at the positive side of the connector.
 - c Press the battery straight down into the connector until it snaps into place.
- 7 Replace the computer cover (see page 91).

- NOTICE:** To connect a network cable, first plug the cable into the network device and then plug it into the computer.
- 8 Connect your computer and devices to electrical outlets, and turn them on.
 - 9 Enter system setup (see page 97) and restore the settings you recorded in step 1.
 - 10 Properly dispose of the old battery. See the *Product Information Guide* for battery disposal information.

Replacing the Computer Cover

CAUTION: Before you begin any of the procedures in this section, follow the safety instructions located in the *Product Information Guide*.

- 1 Ensure that all cables are connected, and fold cables out of the way.
Gently pull the power cables toward you so that they do not get caught underneath the drives.
- 2 Ensure that no tools or extra parts are left inside the computer.
- 3 Install the cover:
 - a Align the bottom of the cover with the tabs located along the bottom of edge of the computer.
 - b Using the tabs as leverage, rotate the cover downward.

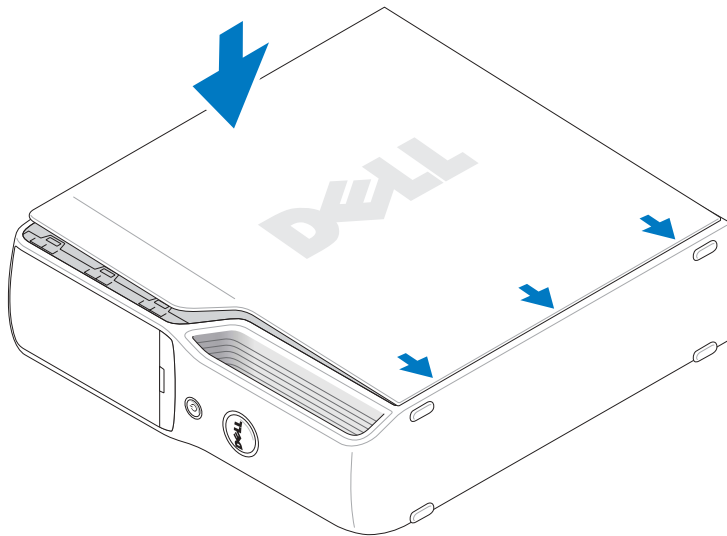

- c Snap the cover into place by pulling back on the cover release latch, and then releasing the latch when the cover is properly seated.

- d** Ensure that the cover is seated correctly before moving the computer to the upright position.
-  **NOTICE:** To connect a network cable, first plug the cable into the network device and then plug it into the computer.
- 4** Connect your computer and devices to electrical outlets, and turn them on.

Appendix

Specifications

Processor	
Processor types	Intel® Pentium® 4 5XX processors with Hyper-Threading technology Intel Celeron® D processors
Level 1 (L1) cache	16 KB
Level 2 (L2) cache	1 MB for Pentium 4 processors 256 KB for Celeron processors (depending on your computer configuration) pipelined-burst, eight-way set associative, write-back SRAM
Memory	
Type	400-MHz and 533-MHz DDR2 unbuffered SDRAM
Memory connectors	four
Memory capacities	256-MB, 512-MB, 1-GB, or 2-GB non-ECC
Minimum memory	256 MB
Maximum memory	4 GB NOTE: See "Addressing Memory With 4-GB Configurations" on page 64 to verify the amount of memory available to the operating system.
BIOS address	F0000h
Computer Information	
Chip set	Intel 945G Express chip set
DMA channels	eight
Interrupt levels	24
BIOS chip (NVRAM)	4 Mb
NIC	integrated network interface capable of 10/100-Mbps communication

Computer Information (continued)	
System clock	800-MHz data rate
Video	
Type	Intel integrated Graphics Media Accelerator (GMA) 950
Audio	
Type	Sigmatel STAC9220
Expansion Bus	
Bus type	PCI Express x1 and x16
Bus speed	PCI Express: x1 slot bidirectional speed: 500 MB/s x16 slot bidirectional speed: 8 GB/sec
PCI Express:	
connector	one x1
connector size	36 pins
connector data width (maximum)	one PCI Express lane
PCI Express:	
connector	one x16
connector size	164 pins
connector data width (maximum)	16 PCI Express lanes
Drives	
Externally accessible	one slimline 3.5-inch media bay one slimline 5.25-inch drive bay
Available devices	Serial ATA drive, USB memory devices, CD drive, DVD drive, DVD+RW drive, DVD/CD-RW combo drive, DVD+/-RW, and media card reader
Internally accessible	one bay for 1-inch high hard drive

Connectors

External connectors:

Serial	9-pin, 16550C-compatible connector
IEEE 1394	one 6-pin powered back-panel connector (not present on certain computers) one 6-pin powered front-panel connector (with optional media card reader)
Video	15-hole D-SUB connector
USB	two front-panel and five back-panel USB 2.0-compliant connectors
Headphone	front-panel miniature connector for line-out
Audio	five connectors for line-in, line-out, microphone, surround sound, and center/Low Frequency Effects (LFE) channel; S/PDIF back-panel connector (S/PDIF connector may not be present on certain computers)
Network adapter	RJ45 connector
Modem	RJ11 (MDC 1.5) connector

System board connectors:

IDE drive	one 40-pin connector
Serial ATA	one 7-pin connectors
Fan	one 5-pin connectors
PCI Express x1	36-pin connector
PCI Express x16	164-pin connector
USB	8-pin header for optional media card reader (3.5-inch bay device)
MDC	one 12-pin connector
Front-panel audio	one 10-pin header
Front panel	one 34-pin header
Power	one 2 x 10 connector
Processor power	one 2 x 2 connector
IEEE 1394	one 2 x 5 header for optional media card reader (3.5-inch bay device)

Controls and Lights

Power control	push button
Power light	green light — Blinking green in sleep state; solid green for power-on state. amber light — Blinking amber indicates a problem with an installed device; solid amber indicates an internal power problem (see "Power Problems" on page 36).
Hard-drive access light	green
Link integrity light (on integrated network adapter)	green light — A good connection exists between a 10-Mbps network and the computer. orange light — A good connection exists between a 100-Mbps network and the computer. off (no light) — The computer is not detecting a physical connection to the network.
Activity light (on integrated network adapter)	yellow blinking light
Diagnostic lights	four lights on the back panel (See "Diagnostic Lights" on page 43 for an explanation of the diagnostic light codes.)
Standby power light	AUX_PWR on the system board
Activity light (optional media card reader)	green blinking light

Power

DC power supply:	
Wattage	270 W
Heat dissipation	460.7 BTU/hr
Voltage (See the safety instructions in the <i>Product Information Guide</i> for important voltage setting information.)	fixed-voltage power supply — 110 V at 50/60 Hz manual selection and auto-sensing power supplies — 90 to 135 V at 50/60 Hz; 180 to 265 V at 50/60 Hz; 100 V at 50/60 Hz for Japanese computers
Backup battery	3-V CR2032 lithium coin cell

Physical

Height	31 cm (12.2 inches)
Width	9.1 cm (3.6 inches)
Depth	36.3 cm (14.3 inches)
Weight	7.4 kg (16.4 lb)

Environmental

Temperature:

Operating	10° to 35°C (50° to 95°F) NOTE: At 35°C (95°F), the maximum operating altitude is 914 m (3000 ft).
-----------	--

Storage	-40° to 65°C (-40° to 149°F)
---------	------------------------------

Relative humidity	20% to 80% (noncondensing)
-------------------	----------------------------

Maximum vibration:

Operating	0.25 G at 3 to 200 Hz at 0.5 octave/min
-----------	---

Storage	0.5 G at 3 to 200 Hz at 1 octave/min
---------	--------------------------------------

Maximum shock:

Operating	bottom half-sine pulse with a change in velocity of 50.8 cm/sec (20 inches/sec)
-----------	---

Storage	27-G faired square wave with a velocity change of 508 cm/sec (200 inches/sec)
---------	---

Altitude:

Operating	-15.2 to 3048 m (-50 to 10,000 ft)
-----------	------------------------------------

Storage	-15.2 to 10,668 m (-50 to 35,000 ft)
---------	--------------------------------------

System Setup

Overview

Use system setup as follows:

- To change the system configuration information after you add, change, or remove any hardware in your computer
- To set or change a user-selectable option such as the user password
- To read the current amount of memory or set the type of hard drive installed

Before you use system setup, it is recommended that you write down the system setup screen information for future reference.

 **NOTICE:** Unless you are an expert computer user, do not change the settings for this program. Certain changes can make your computer work incorrectly.

Entering System Setup

- 1 Turn on (or restart) your computer.
- 2 When the blue DELL™ logo appears, press <F2> immediately.

If you wait too long and the operating system logo appears, continue to wait until you see the Microsoft® Windows® desktop. Then shut down your computer (see page 53) and try again.

System Setup Screens

The system setup screen displays current or changeable configuration information for your computer. Information on the screen is divided into three areas: the options list, active options field, and key functions.

<p>Options List — This field appears on the left side of the system setup window. The field is a scrollable list containing features that define the configuration of your computer, including installed hardware, power conservation, and security features.</p>	<p>Option Field — This field contains information about each option. In this field you can view your current settings and make changes to your settings.</p> <p>Use the right- and left-arrow keys to highlight an option. Press <Enter> to make that selection active.</p>
<p>Scroll up and down the list with the up- and down-arrow keys. As an option is highlighted, the Option Field displays more information about that option and the option's current and available settings.</p> <p>Press <Enter> to expand or contract each of the main option fields.</p>	<p>Key Functions — This field appears below the Option Field and lists keys and their functions within the active system setup field.</p>

System Setup Options



NOTE: Depending on your computer, BIOS version, and installed devices, the items listed in this section may not appear, or may not appear exactly as listed.

System	
System Info	Lists system information such as the computer name, the BIOS version number and date, system tags, and other system-specific information.
CPU Info	Identifies whether the computer's processor supports Hyper-Threading and lists the processor bus speed, processor ID, clock speed, and L2 cache.
Memory Info	Indicates amount of installed memory, memory speed, channel mode (dual or single), and type of memory installed.
Date/Time	Displays current date and time settings.
Boot Sequence	The computer attempts to boot from the sequence of devices specified in this list. NOTE: If you insert a boot device and restart the computer, this option appears in the system setup menu. To boot from a USB memory device, select the USB device and move it so it becomes the first device in the list.
Drives	
Diskette Drive	Identifies and defines the floppy drive attached to the FLOPPY connector on the system board as Off , USB , Internal , or Read Only .
Drives 0 through 1	Identifies the drives attached to the SATA or PRI IDE connectors on the system board, and lists the capacity for hard drives.
SATA Operation	Identifies and defines the SATA modes. You can set the SATA controller to Normal or Combo mode.
Onboard Devices	
NIC Controller	You can set the NIC to On (default), Off , or On w/ PXE . When the On w/ PXE setting is active (available only for the future boot process), the computer prompts the user to press <Ctrl><Alt>. Pressing this key combination causes a menu to display that allows you to select a method for booting from a network server. If a boot routine is not available from the network server, the computer attempts to boot from the next device in the boot sequence list.
1394 Controller	Enables or disables the IEEE 1394 connections.
Card Reader	Enables or disables the optional media card reader.
Audio Controller	Enables or disables the onboard audio controller.
USB Controller	Set to On (default) so that USB devices will be detected and supported in the operating system. The No Boot option enables a USB controller, but it does not recognize a USB storage device.

Video	
Primary Video	This setting specifies which video controller is primary when two video controllers are present on the computer.
Video Memory Size	Use this option to select 8 MB (default) or 1 MB of system memory for an integrated video controller.
Performance	
HyperThreading	If your computer's processor supports Hyper-Threading, this option appears in the Options List .
SpeedStep	This field specifies whether Enhanced SpeedStep Technology will be enabled for all supported processor(s) in the computer.
HDD Acoustic Mode	<ul style="list-style-type: none"> • Bypass — Your computer does not test or change the current acoustics mode setting. • Quiet (default) — The hard drive operates at its most quiet setting. • Suggested — The hard drive operates at the level suggested by the drive manufacturer. • Performance — The hard drive operates at its maximum speed. <p>NOTE: Switching to performance mode may cause the drive to be noisier, but the drive's performance is not affected.</p> <p>NOTE: Changing the acoustics setting does not alter your hard drive image.</p>
Security	
This section displays available system security options.	
DEP (Execute Disable)	<ul style="list-style-type: none"> • Opt-In (default) — DEP is enabled by default on computers with NX-capable processors. Only Windows system binaries are covered by DEP with this option. Applications may enable DEP protection through creating an application compatibility shim and installing that shim with the application. • Opt-Out — DEP is enabled for all processes. Users can manually create exceptions for specific applications in System Properties, or IT Pros and ISVs can use the Application Compatibility Toolkit to opt-out. • Always On — Full DEP coverage with no exceptions. • Always Off — No user-mode DEP coverage. Drivers and the Windows core kernel binaries are covered by DEP, but no other binaries are included in the set of covered applications.
Unlock Setup	Use this option with Admin Password to unlock setup options. NOTE: This option appears only when the Admin Password option is enabled.
Admin Password	This option provides restricted access to the computer's system setup in the same way that access to the computer can be restricted with the System Password option. NOTE: To delete a password, enter the old password and press <Enter> two times.

System Password	Displays the current status of the system's password security feature and allows a new system password to be assigned and verified.
Password Status	This option locks the system password field with the setup password. When the field is locked, you can no longer disable password security by pressing <Ctrl><Enter> when the computer starts.
Power Management	
AC Recovery	Determines what happens when AC power is restored to the computer.
Auto Power On	Sets the computer to automatically turn on. Choices are every day or every Monday through Friday . The default setting is Off . This feature does not work if you turn off your computer using a power strip or surge protector.
Auto Power Time	Sets time to automatically turn on the computer. Time is kept in a 24-hour format (<i>hours:minutes</i>). Change the start-up time by pressing the right- or left-arrow key to increase or decrease the numbers, or type numbers in both the date and time fields. This feature does not work if you turn off your computer using a power strip or surge protector.
Low Power Mode	Use this mode to conserve power.
Suspend Mode	The options are S1 , a suspend state where the computer is running in a low-power mode, and S3 , a standby state where the power is reduced or turned off for most components, however, system memory remains active.
Maintenance	
Load Defaults	This setting restores the computer's factory-installed default settings.
Event Log	Displays the system event log.
POST Behavior	
Fastboot	When set to On (default), your computer starts more quickly because it skips certain configurations and tests.
Numlock Key	This option involves the rightmost bank of keys on your keyboard. When set to On (default), this option activates the numeric and mathematical features shown at the top of each key. When set to Off , this option activates the cursor-control functions labeled on the bottom of each key.
POST Hotkeys	This option allows you to specify the function keys to display on the screen when the computer starts.
Keyboard Errors	This option disables or enables keyboard error reporting when the computer starts.

Boot Sequence

This feature allows you to change the boot sequence for devices.



NOTICE: If you modify any boot sequence settings, save the new settings to avoid losing the changes.

Option Settings

- **Diskette Drive** — The computer attempts to boot from the floppy drive. If the floppy disk in the drive is not bootable, if no floppy disk is in the drive, or if there is no floppy drive installed in the computer, the computer generates an error message.
- **Hard Drive** — The computer attempts to boot from the primary hard drive. If no operating system is on the drive, the computer generates an error message.
- **CD Drive** — The computer attempts to boot from the CD drive. If no CD is in the drive, or if the CD has no operating system, the computer generates an error message.
- **USB Flash Device** — Insert the memory device into a USB port and restart the computer. When **F12 = Boot Menu** appears in the upper-right corner of the screen, press <F12>. The BIOS detects the device and adds the USB flash option to the boot menu.



NOTE: To boot to a USB device, the device must be bootable. To make sure that your device is bootable, check the device documentation.

Changing Boot Sequence for the Current Boot

You can use this feature, for example, to restart your computer to a USB device such as a floppy drive, or memory key.

- 1 If you are booting to a USB device, connect the USB device to a USB connector (see page 62).
- 2 Turn on (or restart) your computer.
- 3 When **F2 = Setup**, **F12 = Boot Menu** appears in the upper-right corner of the screen, press <F12>.

If you wait too long and the operating system logo appears, continue to wait until you see the Microsoft Windows desktop. Then shut down your computer (see page 53) and try again.

The **Boot Device Menu** appears, listing all available boot devices.

- 4 Select a device and press <Enter>.

For example, if you are booting to a USB memory key, highlight **USB Flash Device** and press <Enter>.



NOTE: To boot to a USB device, the device must be bootable. To make sure your device is bootable, check the device documentation.



NOTE: You can also change the boot sequence using the Boot Sequence options in the **System Setup Options** (see page 99).

Changing Boot Sequence for Future Boots

- 1 Enter system setup (see page 98).
- 2 Press the arrow keys to highlight the **Boot Sequence** menu option and press <Enter> to access the menu.

 **NOTE:** Write down your current boot sequence in case you want to restore it.

- 3 Press the up- and down-arrow keys to move through the list of devices.
- 4 Press the spacebar to enable or disable a device (enabled devices have a checkmark).
- 5 Press the <u> key or the <d> key to move a selected device up or down the list.

Clearing Forgotten Passwords

 **CAUTION:** Before you begin any of the procedures in this section, follow the safety instructions located in the *Product Information Guide*.

- 1 Follow the procedures in "Before You Begin" on page 53.

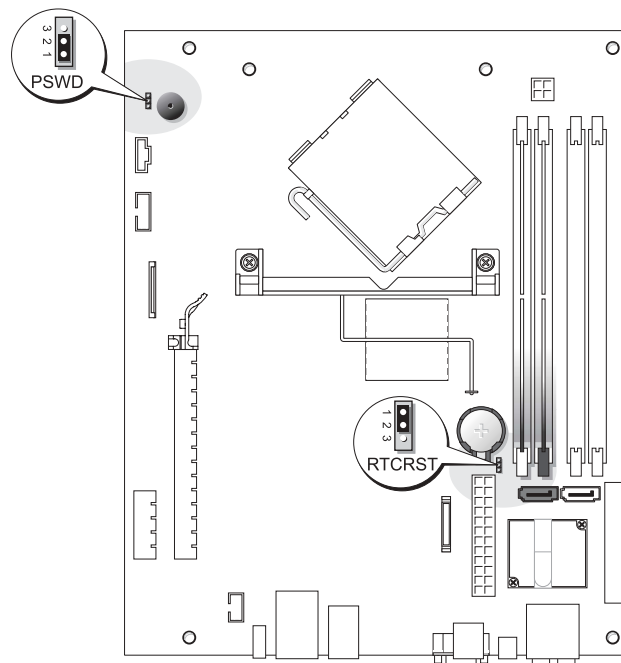

- 2 Locate the 3-pin password jumper (PSWD) on the system board, and attach the jumper plug to pins 1 and 2 to clear the password.

 **NOTE:** When you receive your computer, the jumper plug is attached to pins 2 and 3.

- 3 Replace the computer cover (see page 91).
- 4 Connect your computer and monitor to electrical outlets, and turn them on.
- 5 After the Microsoft® Windows® desktop appears on your computer, shut down the computer (see page 53).
- 6 Turn off the monitor and disconnect it from the electrical outlet.
- 7 Disconnect the computer power cable from the electrical outlet, and press the power button to ground the system board.
- 8 Remove the computer cover (see page 59).
- 9 Locate the 3-pin password jumper (PSWD) on the system board (see page 103) and attach the jumper to pins 2 and 3 to re-enable the password feature.
- 10 Replace the computer cover (see page 91).
-  **NOTICE:** To connect a network cable, first plug the cable into the network device and then plug it into the computer.
- 11 Connect your computer and devices to electrical outlets, and turn them on.

Clearing CMOS Settings

 **CAUTION:** Before you begin any of the procedures in this section, follow the safety instructions located in the *Product Information Guide*.

- 1 Follow the procedures in "Before You Begin" on page 53.
- 2 Reset the current CMOS settings:
 - a Locate the 3-pin CMOS jumper (RTCRST) on the system board (see page 103).
 - b Remove the jumper plug from pins 1 and 2.
 - c Place the jumper plug on pins 2 and 3 and wait approximately 5 seconds.
 - d Replace the jumper plug on pins 1 and 2.
- 3 Replace the computer cover (see page 91).
-  **NOTICE:** To connect a network cable, first plug the cable into the network wall jack and then plug it into the computer.
- 4 Connect your computer and devices to electrical outlets, and turn them on.

Cleaning Your Computer

 **CAUTION:** Before you begin any of the procedures in this section, follow the safety instructions located in the *Product Information Guide*.

Computer, Keyboard, and Monitor

 **CAUTION:** Before you clean your computer, disconnect the computer from the electrical outlet. Clean your computer with a soft cloth dampened with water. Do not use liquid or aerosol cleaners, which may contain flammable substances.

- Use a vacuum cleaner with a brush attachment to gently remove dust from the slots and holes on your computer and from between the keys on the keyboard.

 **NOTICE:** Do not wipe the display screen with any soap or alcohol solution. Doing so may damage the antiglare coating.

- To clean your monitor screen, lightly dampen a soft, clean cloth with water. If possible, use a special screen-cleaning tissue or solution suitable for the monitor's antistatic coating.
- Wipe the keyboard, computer, and plastic part of the monitor with a soft cleaning cloth moistened with a solution of three parts water and one part dishwashing detergent.
Do not soak the cloth or let water drip inside your computer or keyboard.

Mouse

If your screen cursor skips or moves abnormally, clean the mouse. To clean a non-optical mouse:

- 1 Turn the retainer ring on the underside of your mouse counterclockwise, and then remove the ball.
- 2 Wipe the ball with a clean, lint-free cloth.
- 3 Blow carefully into the ball cage to dislodge dust and lint.
- 4 If the rollers inside the ball cage are dirty, clean the rollers with a cotton swab moistened lightly with isopropyl alcohol.
- 5 Recenter the rollers in their channels if they are misaligned. Ensure that fluff from the swab is not left on the rollers.
- 6 Replace the ball and retainer ring, and turn the retainer ring clockwise until it clicks into place.

CDs and DVDs

- ➡ **NOTICE:** Always use compressed air to clean the lens in the CD/DVD drive, and follow the instructions that come with the compressed air. Never touch the lens in the drive.

If you notice problems, such as skipping, with the playback quality of your CDs or DVDs, try cleaning the discs.

- 1 Hold the disc by its outer edge. You can also touch the inside edge of the center hole.

- ➡ **NOTICE:** To prevent damaging the surface, do not wipe in a circular motion around the disc.

- 2 With a soft, lint-free cloth, gently wipe the bottom of the disc (the unlabeled side) in a straight line from the center to the outer edge of the disc.

For stubborn dirt, try using water or a diluted solution of water and mild soap. You can also purchase commercial products that clean discs and provide some protection from dust, fingerprints, and scratches. Cleaning products for CDs are safe to use on DVDs.

Dell Technical Support Policy (U.S. Only)

Technician-assisted technical support requires the cooperation and participation of the customer in the troubleshooting process and provides for restoration of the operating system, software programs, and hardware drivers to the original default configuration as shipped from Dell, as well as the verification of appropriate functionality of the computer and all Dell-installed hardware. In addition to this technician-assisted technical support, online technical support is available at support.dell.com. Additional technical support options may be available for purchase.

Dell provides limited technical support for the computer and any "Dell-installed" software and peripherals¹. Support for third-party software and peripherals is provided by the original manufacturer, including those purchased and/or installed through Dell Software and Peripherals, Readyware, and Custom Factory Integration².

¹ Repair services are provided pursuant to the terms and conditions of your limited warranty and any optional support service contract purchased with the computer.

² All Dell-standard components included in a Custom Factory Integration (CFI) project are covered by the standard Dell limited warranty for your computer. However, Dell also extends a parts replacement program to cover all nonstandard, third-party hardware components integrated through CFI for the duration of the computer's service contract.

Definition of "Dell-Installed" Software and Peripherals

Dell-installed software includes the operating system and some of the software programs that are installed on the computer during the manufacturing process (Microsoft® Office, Norton Antivirus, and so on).

Dell-installed peripherals include any internal expansion cards, or Dell-branded module bay or PC Card accessories. In addition, any Dell-branded monitors, keyboards, mice, speakers, microphones for telephonic modems, docking stations/port replicators, networking products, and all associated cabling are included.

Definition of "Third-Party" Software and Peripherals

Third-party software and peripherals include any peripheral, accessory, or software program sold by Dell not under the Dell brand (printers, scanners, cameras, games, and so on). Support for all third-party software and peripherals is provided by the original manufacturer of the product.

FCC Notices (U.S. Only)

Most Dell computer systems are classified by the Federal Communications Commission (FCC) as Class B digital devices. To determine which classification applies to your computer system, examine all FCC registration labels located on the bottom, side, or back panel of your computer, on card-mounting brackets, and on the cards themselves. If any one of the labels carries a Class A rating, your entire system is considered to be a Class A digital device. If *all* labels carry an FCC Class B rating as distinguished by either an FCC ID number or the FCC logo, (**FCC**), your system is considered to be a Class B digital device.

Once you have determined your system's FCC classification, read the appropriate FCC notice. Note that FCC regulations provide that changes or modifications not expressly approved by Dell could void your authority to operate this equipment.

This device complies with Part 15 of the FCC Rules. Operation is subject to the following two conditions:

- This device may not cause harmful interference.
- This device must accept any interference received, including interference that may cause undesired operation.

Class A

This equipment has been tested and found to comply with the limits for a Class A digital device pursuant to Part 15 of the FCC Rules. These limits are designed to provide reasonable protection against harmful interference when the equipment is operated in a commercial environment. This equipment generates, uses, and can radiate radio frequency energy and, if not installed and used in accordance with the manufacturer's instruction manual, may cause harmful interference with radio communications. Operation of this equipment in a residential area is likely to cause harmful interference, in which case you will be required to correct the interference at your own expense.

Class B

This equipment has been tested and found to comply with the limits for a Class B digital device pursuant to Part 15 of the FCC Rules. These limits are designed to provide reasonable protection against harmful interference in a residential installation. This equipment generates, uses, and can radiate radio frequency energy and, if not installed and used in accordance with the manufacturer's instruction manual, may cause interference with radio communications. However, there is no guarantee that interference will not occur in a particular installation. If this equipment does cause

harmful interference to radio or television reception, which can be determined by turning the equipment off and on, you are encouraged to try to correct the interference by one or more of the following measures:

- Reorient or relocate the receiving antenna.
- Increase the separation between the equipment and the receiver.
- Connect the equipment into an outlet on a circuit different from that to which the receiver is connected.
- Consult the dealer or an experienced radio/television technician for help.

FCC Identification Information

The following information is provided on the device or devices covered in this document in compliance with FCC regulations:

- Model number: DHP

Company name:

Dell Inc.
One Dell Way
Round Rock, Texas 78682 USA
512-338-4400

Contacting Dell

To contact Dell electronically, you can access the following websites:

- www.dell.com
- support.dell.com (technical support)
- premiersupport.dell.com (technical support for educational, government, healthcare, and medium/large business customers, including Premier, Platinum, and Gold customers)

For specific web addresses for your country, find the appropriate country section in the table below.

NOTE: Toll-free numbers are for use within the country for which they are listed.

When you need to contact Dell, use the electronic addresses, telephone numbers, and codes provided in the following table. If you need assistance in determining which codes to use, contact a local or an international operator.

Country (City) International Access Code Country Code City Code	Department Name or Service Area, Website and E-Mail Address	Area Codes, Local Numbers, and Toll-Free Numbers
Anguilla	General Support	toll-free: 800-335-0031
Antigua and Barbuda	General Support	1-800-805-5924
Argentina (Buenos Aires)	Website: www.dell.com.ar	
International Access Code: 00	E-mail: us_latin_services@dell.com	
Country Code: 54	E-mail for desktop and portable computers: la-techsupport@dell.com	
City Code: 11	E-mail for servers and EMC: la_enterprise@dell.com	
	Customer Care	toll-free: 0-800-444-0730
	Tech Support	toll-free: 0-800-444-0733
	Tech Support Services	toll-free: 0-800-444-0724
	Sales	0-810-444-3355
Aruba	General Support	toll-free: 800-1578
Australia (Sydney)	E-mail (Australia): au_tech_support@dell.com	
International Access Code: 0011	E-mail (New Zealand): nz_tech_support@dell.com	
Country Code: 61	Home and Small Business	1-300-65-55-33
City Code: 2	Government and Business	toll-free: 1-800-633-559
	Preferred Accounts Division (PAD)	toll-free: 1-800-060-889
	For servers and storage	toll-free: 1-800-505-095
	For desktop and portable computers	toll-free: 1-800-733-314
	Customer Care	toll-free: 1-800-819-339
	Corporate Sales	toll-free: 1-800-808-385
	Transaction Sales	toll-free: 1-800-808-312
	Fax	toll-free: 1-800-818-341

Country (City) International Access Code Country Code City Code	Department Name or Service Area, Website and E-Mail Address	Area Codes, Local Numbers, and Toll-Free Numbers
Austria (Vienna)	Website: support.euro.dell.com	
International Access Code: 900	E-mail: tech_support_central_europe@dell.com	
Country Code: 43	Home/Small Business Sales	0820 240 530 00
City Code: 1	Home/Small Business Fax	0820 240 530 49
	Home/Small Business Customer Care	0820 240 530 14
	Preferred Accounts/Corporate Customer Care	0820 240 530 16
	Home/Small Business Technical Support	0820 240 530 14
	Preferred Accounts/Corporate Technical Support	0660 8779
	Switchboard	0820 240 530 00
Bahamas	General Support	toll-free: 1-866-278-6818
Barbados	General Support	1-800-534-3066
Belgium (Brussels)	Website: support.euro.dell.com	
International Access Code: 00	E-mail for French Speaking Customers: support.euro.dell.com/be/fr/emaildell/	
Country Code: 32	Technical Support	02 481 92 88
City Code: 2	Technical Support Fax	02 481 92 95
	Customer Care	02 713 15 .65
	Corporate Sales	02 481 91 00
	Fax	02 481 92 99
	Switchboard	02 481 91 00
Bermuda	General Support	1-800-342-0671
Bolivia	General Support	toll-free: 800-10-0238
Brazil	Website: www.dell.com/br	
International Access Code: 00	Customer Support, Technical Support	0800 90 3355
Country Code: 55	Technical Support Fax	51 481 5470
City Code: 51	Customer Care Fax	51 481 5480
	Sales	0800 90 3390
British Virgin Islands	General Support	toll-free: 1-866-278-6820
Brunei	Customer Technical Support (Penang, Malaysia)	604 633 4966
Country Code: 673	Customer Service (Penang, Malaysia)	604 633 4949
	Transaction Sales (Penang, Malaysia)	604 633 4955

Country (City) International Access Code Country Code City Code	Department Name or Service Area, Website and E-Mail Address	Area Codes, Local Numbers, and Toll-Free Numbers
Canada (North York, Ontario) International Access Code: 011	Online Order Status: www.dell.ca/ostatus AutoTech (automated technical support) Customer Care (Home Sales/Small Business) Customer Care (med./large business, government) Technical Support (Home Sales/Small Business) Technical Support (med./large bus., government) Sales (Home Sales/Small Business) Sales (med./large bus., government) Spare Parts Sales & Extended Service Sales	toll-free: 1-800-247-9362 toll-free: 1-800-847-4096 toll-free: 1-800-326-9463 toll-free: 1-800-847-4096 toll-free: 1-800-387-5757 toll-free: 1-800-387-5752 toll-free: 1-800-387-5755 1 866 440 3355
Cayman Islands	General Support	1-800-805-7541
Chile (Santiago) Country Code: 56 City Code: 2	Sales, Customer Support, and Technical Support	toll-free: 1230-020-4823

Country (City) International Access Code Country Code City Code	Department Name or Service Area, Website and E-Mail Address	Area Codes, Local Numbers, and Toll-Free Numbers
China (Xiamen)	Technical Support website: support.dell.com.cn	
Country Code: 86	Technical Support E-mail: cn_support@dell.com	
City Code: 592	Technical Support Fax	818 1350
	Technical Support (Dimension™ and Inspiron™)	toll-free: 800 858 2969
	Technical Support (OptiPlex™, Latitude™, and Dell Precision™)	toll-free: 800 858 0950
	Technical Support (servers and storage)	toll-free: 800 858 0960
	Technical Support (projectors, PDAs, printers, switches, routers, and so on)	toll-free: 800 858 2920
	Customer Advocacy	toll-free: 800 858 2060
	Customer Advocacy Fax	592 818 1308
	Home and Small Business	toll-free: 800 858 2222
	Preferred Accounts Division	toll-free: 800 858 2557
	Large Corporate Accounts GCP	toll-free: 800 858 2055
	Large Corporate Accounts Key Accounts	toll-free: 800 858 2628
	Large Corporate Accounts North	toll-free: 800 858 2999
	Large Corporate Accounts North Government and Education	toll-free: 800 858 2955
	Large Corporate Accounts East	toll-free: 800 858 2020
	Large Corporate Accounts East Government and Education	toll-free: 800 858 2669
	Large Corporate Accounts Queue Team	toll-free: 800 858 2572
	Large Corporate Accounts South	toll-free: 800 858 2355
	Large Corporate Accounts West	toll-free: 800 858 2811
	Large Corporate Accounts Spare Parts	toll-free: 800 858 2621
Colombia	General Support	980-9-15-3978
Costa Rica	General Support	0800-012-0435

Country (City) International Access Code Country Code City Code	Department Name or Service Area, Website and E-Mail Address	Area Codes, Local Numbers, and Toll-Free Numbers
Czech Republic (Prague)	Website: support.euro.dell.com	
International Access Code: 00	E-mail: czech_dell@dell.com	
Country Code: 420	Technical Support	02 2186 27 27
City Code: 2	Technical Support Fax	02 2186 27 28
	Customer Care	02 2186 27 11
	Customer Care Fax	02 2186 27 14
	Switchboard	02 2186 27 11
Denmark (Copenhagen)	Website: support.euro.dell.com	
International Access Code: 00	E-mail Support (portable computers): den_nbk_support@dell.com	
Country Code: 45	E-mail Support (desktop computers): den_support@dell.com	
	E-mail Support (servers): Nordic_server_support@dell.com	
	Technical Support	7023 0182
	Customer Care (Relational)	7023 0184
	Home/Small Business Customer Care	3287 5505
	Switchboard (Relational)	3287 1200
	Switchboard Fax (Relational)	3287 1201
	Switchboard (Home/Small Business)	3287 5000
	Switchboard Fax (Home/Small Business)	3287 5001
Dominica	General Support	toll-free: 1-866-278-6821
Dominican Republic	General Support	1-800-148-0530
Ecuador	General Support	toll-free: 999-119
El Salvador	General Support	01-899-753-0777

Country (City) International Access Code Country Code City Code	Department Name or Service Area, Website and E-Mail Address	Area Codes, Local Numbers, and Toll-Free Numbers
Finland (Helsinki)	Website: support.euro.dell.com	
International Access Code: 990	E-mail: fin_support@dell.com	
Country Code: 358	E-mail Support (servers):	
City Code: 9	Nordic_support@dell.com	
	Technical Support	09 253 313 60
	Technical Support Fax	09 253 313 81
	Relational Customer Care	09 253 313 38
	Home/Small Business Customer Care	09 693 791 94
	Fax	09 253 313 99
	Switchboard	09 253 313 00
France (Paris) (Montpellier)	Website: support.euro.dell.com	
International Access Code: 00	E-mail: support.euro.dell.com/fr/fr/emaildell/	
Country Code: 33	Home and Small Business	
City Codes: (1) (4)	Technical Support	0825 387 270
	Customer Care	0825 823 833
	Switchboard	0825 004 700
	Switchboard (calls from outside of France)	04 99 75 40 00
	Sales	0825 004 700
	Fax	0825 004 701
	Fax (calls from outside of France)	04 99 75 40 01
	Corporate	
	Technical Support	0825 004 719
	Customer Care	0825 338 339
	Switchboard	01 55 94 71 00
	Sales	01 55 94 71 00
	Fax	01 55 94 71 01

Country (City) International Access Code Country Code City Code	Department Name or Service Area, Website and E-Mail Address	Area Codes, Local Numbers, and Toll-Free Numbers
Germany (Langen) International Access Code: 00 Country Code: 49 City Code: 6103	Website: support.euro.dell.com E-mail: tech_support_central_europe@dell.com Technical Support Home/Small Business Customer Care Global Segment Customer Care Preferred Accounts Customer Care Large Accounts Customer Care Public Accounts Customer Care Switchboard	06103 766-7200 0180-5-224400 06103 766-9570 06103 766-9420 06103 766-9560 06103 766-9555 06103 766-7000
Greece International Access Code: 00 Country Code: 30	Website: support.euro.dell.com E-mail: support.euro.dell.com/gr/en/emaildell/ Technical Support Gold Service Technical Support Switchboard Gold Service Switchboard Sales Fax	00800-44 14 95 18 00800-44 14 00 83 2108129810 2108129811 2108129800 2108129812
Grenada	General Support	toll-free: 1-866-540-3355
Guatemala	General Support	1-800-999-0136
Guyana	General Support	toll-free: 1-877-270-4609
Hong Kong International Access Code: 001 Country Code: 852	Website: support.ap.dell.com E-mail: apsupport@dell.com Technical Support (Dimension™ and Inspiron™) Technical Support (OptiPlex™, Latitude™, and Dell Precision™) Technical Support (PowerApp™, PowerEdge™, PowerConnect™, and PowerVault™) Gold Queue EEC Hotline Customer Advocacy Large Corporate Accounts Global Customer Programs Medium Business Division	2969 3188 2969 3191 2969 3196 2969 3187 3416 0910 3416 0907 3416 0908 3416 0912

Country (City) International Access Code Country Code City Code	Department Name or Service Area, Website and E-Mail Address	Area Codes, Local Numbers, and Toll-Free Numbers
	Home and Small Business Division	2969 3155
India	Technical Support	1600 33 8045
	Sales	1600 33 8044
Ireland (Cherrywood)	Website: support.euro.dell.com	
International Access Code: 16	E-mail: dell_direct_support@dell.com	
Country Code: 353	Technical Support	1850 543 543
City Code: 1	U.K. Technical Support (dial within U.K. only)	0870 908 0800
	Home User Customer Care	01 204 4014
	Small Business Customer Care	01 204 4014
	U.K. Customer Care (dial within U.K. only)	0870 906 0010
	Corporate Customer Care	1850 200 982
	Corporate Customer Care (dial within U.K. only)	0870 907 4499
	Ireland Sales	01 204 4444
	U.K. Sales (dial within U.K. only)	0870 907 4000
	Fax/Sales Fax	01 204 0103
	Switchboard	01 204 4444
Italy (Milan)	Website: support.euro.dell.com	
International Access Code: 00	E-mail: support.euro.dell.com/it/it/emaildell/	
Country Code: 39	Home and Small Business	
City Code: 02	Technical Support	02 577 826 90
	Customer Care	02 696 821 14
	Fax	02 696 821 13
	Switchboard	02 696 821 12
	Corporate	
	Technical Support	02 577 826 90
	Customer Care	02 577 825 55
	Fax	02 575 035 30
	Switchboard	02 577 821
Jamaica	General Support (dial from within Jamaica only)	1-800-682-3639

Country (City) International Access Code Country Code City Code	Department Name or Service Area, Website and E-Mail Address	Area Codes, Local Numbers, and Toll-Free Numbers
Japan (Kawasaki)	Website: support.jp.dell.com	
International Access Code: 001	Technical Support (servers)	toll-free: 0120-198-498
Country Code: 81	Technical Support outside of Japan (servers)	81-44-556-4162
City Code: 44	Technical Support (Dimension™ and Inspiron™)	toll-free: 0120-198-226
	Technical Support outside of Japan (Dimension and Inspiron)	81-44-520-1435
	Technical Support (Dell Precision™, OptiPlex™, and Latitude™)	toll-free:0120-198-433
	Technical Support outside of Japan (Dell Precision, OptiPlex, and Latitude)	81-44-556-3894
	Technical Support (PDAs, projectors, printers, routers)	toll-free: 0120-981-690
	Technical Support outside of Japan (PDAs, projectors, printers, routers)	81-44-556-3468
	Faxbox Service	044-556-3490
	24-Hour Automated Order Service	044-556-3801
	Customer Care	044-556-4240
	Business Sales Division (up to 400 employees)	044-556-1465
	Preferred Accounts Division Sales (over 400 employees)	044-556-3433
	Large Corporate Accounts Sales (over 3500 employees)	044-556-3430
	Public Sales (government agencies, educational institutions, and medical institutions)	044-556-1469
	Global Segment Japan	044-556-3469
	Individual User	044-556-1760
	Switchboard	044-556-4300
Korea (Seoul)	Technical Support	toll-free: 080-200-3800
International Access Code: 001	Sales	toll-free: 080-200-3600
Country Code: 82	Customer Service (Seoul, Korea)	toll-free: 080-200-3800
City Code: 2	Customer Service (Penang, Malaysia)	604 633 4949
	Fax	2194-6202
	Switchboard	2194-6000

Country (City) International Access Code Country Code City Code	Department Name or Service Area, Website and E-Mail Address	Area Codes, Local Numbers, and Toll-Free Numbers
Latin America	Customer Technical Support (Austin, Texas, U.S.A.)	512 728-4093
	Customer Service (Austin, Texas, U.S.A.)	512 728-3619
	Fax (Technical Support and Customer Service) (Austin, Texas, U.S.A.)	512 728-3883
	Sales (Austin, Texas, U.S.A.)	512 728-4397
	SalesFax (Austin, Texas, U.S.A.)	512 728-4600 or 512 728-3772
Luxembourg	Website: support.euro.dell.com	
International Access Code: 00	E-mail: tech_be@dell.com	
Country Code: 352	Technical Support (Brussels, Belgium)	3420808075
	Home/Small Business Sales (Brussels, Belgium)	toll-free: 080016884
	Corporate Sales (Brussels, Belgium)	02 481 91 00
	Customer Care (Brussels, Belgium)	02 481 91 19
	Fax (Brussels, Belgium)	02 481 92 99
	Switchboard (Brussels, Belgium)	02 481 91 00
Macao	Technical Support	toll-free: 0800 582
Country Code: 853	Customer Service (Penang, Malaysia)	604 633 4949
	Transaction Sales	toll-free: 0800 581
Malaysia (Penang)	Technical Support (Dell Precision, OptiPlex, and Latitude)	toll-free: 1 800 88 0193
International Access Code: 00		
Country Code: 60	Technical Support (Dimension and Inspiron)	toll-free: 1 800 88 1306
City Code: 4	Technical Support (PowerEdge and PowerVault)	toll-free: 1800 88 1386
	Customer Service	04 633 4949
	Transaction Sales	toll-free: 1 800 888 202
	Corporate Sales	toll-free: 1 800 888 213

Country (City) International Access Code Country Code City Code	Department Name or Service Area, Website and E-Mail Address	Area Codes, Local Numbers, and Toll-Free Numbers
Mexico	Customer Technical Support	001-877-384-8979
International Access Code: 00		or 001-877-269-3383
Country Code: 52	Sales	50-81-8800
		or 01-800-888-3355
	Customer Service	001-877-384-8979
		or 001-877-269-3383
	Main	50-81-8800
		or 01-800-888-3355
Montserrat	General Support	toll-free: 1-866-278-6822
Netherlands Antilles	General Support	001-800-882-1519
Netherlands (Amsterdam)	Website: support.euro.dell.com	
International Access Code: 00	Technical Support	020 674 45 00
Country Code: 31	Technical Support Fax	020 674 47 66
City Code: 20	Home/Small Business Customer Care	020 674 42 00
	Relational Customer Care	020 674 4325
	Home/Small Business Sales	020 674 55 00
	Relational Sales	020 674 50 00
	Home/Small Business Sales Fax	020 674 47 75
	Relational Sales Fax	020 674 47 50
	Switchboard	020 674 50 00
	Switchboard Fax	020 674 47 50
New Zealand	E-mail (New Zealand): nz_tech_support@dell.com	
International Access Code: 00	E-mail (Australia): au_tech_support@dell.com	
Country Code: 64	Technical Support (for desktop and portable computers)	0800 443 563
	Technical Support (for servers and storage)	0800 505 098
	Home and Small Business	0800 446 255
	Government and Business	0800 444 617
	Sales	0800 441 567
	Fax	0800 441 566
Nicaragua	General Support	001-800-220-1006

Country (City) International Access Code Country Code City Code	Department Name or Service Area, Website and E-Mail Address	Area Codes, Local Numbers, and Toll-Free Numbers
Norway (Lysaker) International Access Code: 00 Country Code: 47	Website: support.euro.dell.com E-mail Support (portable computers): nor_nbk_support@dell.com E-mail Support (desktop computers): nor_support@dell.com E-mail Support (servers): nordic_server_support@dell.com	Technical Support 671 16882 Relational Customer Care 671 17514 Home/Small Business Customer Care 23162298 Switchboard 671 16800 Fax Switchboard 671 16865
Panama	General Support	001-800-507-0962
Peru	General Support	0800-50-669
Poland (Warsaw) International Access Code: 011 Country Code: 48 City Code: 22	Website: support.euro.dell.com E-mail: pl_support_tech@dell.com Customer Service Phone Customer Care Sales Customer Service Fax Reception Desk Fax Switchboard	57 95 700 57 95 999 57 95 999 57 95 806 57 95 998 57 95 999
Portugal International Access Code: 00 Country Code: 351	Website: support.euro.dell.com E-mail: support.euro.dell.com/pt/en/emailldell/ Technical Support Customer Care Sales Fax	707200149 800 300 413 800 300 410 or 800 300 411 or 800 300 412 or 21 422 07 10 21 424 01 12
Puerto Rico	General Support	1-800-805-7545
St. Kitts and Nevis	General Support	toll-free: 1-877-441-4731

Country (City) International Access Code Country Code City Code	Department Name or Service Area, Website and E-Mail Address	Area Codes, Local Numbers, and Toll-Free Numbers
St. Lucia	General Support	1-800-882-1521
St. Vincent and the Grenadines	General Support	toll-free: 1-877-270-4609
Singapore (Singapore)	Technical Support (Dimension and Inspiron)	toll-free: 1800 394 7430
International Access Code: 005 Country Code: 65	Technical Support (Optiplex, Latitude, and Precision)	toll-free: 1800 394 7488
	Technical Support (PowerEdge and PowerVault)	toll-free: 1800 394 7478
	Customer Service (Penang, Malaysia)	604 633 4949
	Transaction Sales	toll-free: 800 6011 054
	Corporate Sales	toll-free: 800 6011 053
South Africa (Johannesburg)	Website: support.euro.dell.com	
International Access Code: 09/091	E-mail: dell_za_support@dell.com	
Country Code: 27	Gold Queue	011 709 7713
City Code: 11	Technical Support	011 709 7710
	Customer Care	011 709 7707
	Sales	011 709 7700
	Fax	011 706 0495
	Switchboard	011 709 7700
Southeast Asian and Pacific Countries	Customer Technical Support, Customer Service, and Sales (Penang, Malaysia)	604 633 4810
Spain (Madrid)	Website: support.euro.dell.com	
International Access Code: 00	E-mail: support.euro.dell.com/es/es/emaildell/	
Country Code: 34	Home and Small Business	
City Code: 91	Technical Support	902 100 130
	Customer Care	902 118 540
	Sales	902 118 541
	Switchboard	902 118 541
	Fax	902 118 539
	Corporate	
	Technical Support	902 100 130
	Customer Care	902 115 236
	Switchboard	91 722 92 00
	Fax	91 722 95 83

Country (City) International Access Code Country Code City Code	Department Name or Service Area, Website and E-Mail Address	Area Codes, Local Numbers, and Toll-Free Numbers
Sweden (Upplands Vasby) International Access Code: 00 Country Code: 46 City Code: 8	Website: support.euro.dell.com E-mail: swe_support@dell.com E-mail Support for Latitude and Inspiron: Swe-nbk_kats@dell.com E-mail Support for OptiPlex: Swe_kats@dell.com E-mail Support for Servers: Nordic_server_support@dell.com Technical Support Relational Customer Care Home/Small Business Customer Care Employee Purchase Program (EPP) Support Technical Support Fax Sales	 08 590 05 199 08 590 05 642 08 587 70 527 20 140 14 44 08 590 05 594 08 590 05 185
Switzerland (Geneva) International Access Code: 00 Country Code: 41 City Code: 22	Website: support.euro.dell.com E-mail: Tech_support_central_Europe@dell.com E-mail for French-speaking HSB and Corporate Customers: support.euro.dell.com/ch/fr/emaildell/ Technical Support (Home and Small Business) Technical Support (Corporate) Customer Care (Home and Small Business) Customer Care (Corporate) Fax Switchboard	 0844 811 411 0844 822 844 0848 802 202 0848 821 721 022 799 01 90 022 799 01 01
Taiwan International Access Code: 002 Country Code: 886	Technical Support (portable and desktop computers) Technical Support (servers and storage) Corporate Sales	toll-free: 00801 86 1011 toll-free: 00801 60 1256 toll-free: 00801 651 227
Thailand International Access Code: 001 Country Code: 66	Technical Support (Optiplex, Latitude, and Precision) Technical Support (PowerEdge and PowerVault) Customer Service (Penang, Malaysia) Sales	toll-free: 1800 0060 07 toll-free: 1800 0600 09 604 633 4949 toll-free: 0880 060 09

Country (City) International Access Code Country Code City Code	Department Name or Service Area, Website and E-Mail Address	Area Codes, Local Numbers, and Toll-Free Numbers
Trinidad/Tobago	General Support	1-800-805-8035
Turks and Caicos Islands	General Support	toll-free: 1-866-540-3355
U.K. (Bracknell)	Website: support.euro.dell.com	
International Access Code: 00 Country Code: 44 City Code: 1344	Customer Care website: support.euro.dell.com/uk/en/ECare/Form/Home.asp E-mail: dell_direct_support@dell.com	
	Technical Support (Corporate/Preferred Accounts/PAD [1000+ employees])	0870 908 0500
	Technical Support (direct/PAD and general)	0870 908 0800
	Global Accounts Customer Care	01344 373 186
	Home and Small Business Customer Care	0870 906 0010
	Corporate Customer Care	01344 373 185
	Preferred Accounts (500–5000 employees) Customer Care	0870 906 0010
	Central Government Customer Care	01344 373 193
	Local Government & Education Customer Care	01344 373 199
	Health Customer Care	01344 373 194
	Home and Small Business Sales	0870 907 4000
	Corporate/Public Sector Sales	01344 860 456
	Home and Small Business Fax	0870 907 4006
Uruguay	General Support	toll-free: 000-413-598-2521

Country (City) International Access Code Country Code City Code	Department Name or Service Area, Website and E-Mail Address	Area Codes, Local Numbers, and Toll-Free Numbers
U.S.A. (Austin, Texas)	Automated Order-Status Service	toll-free: 1-800-433-9014
International Access Code: 011 Country Code: 1	AutoTech (portable and desktop computers)	toll-free: 1-800-247-9362
	Consumer (Home and Home Office)	
	Technical Support	toll-free: 1-800-624-9896
	Customer Service	toll-free: 1-800-624-9897
	DellNet™ Service and Support	toll-free: 1-877-Dellnet (1-877-335-5638)
	Employee Purchase Program (EPP) Customers	toll-free: 1-800-695-8133
	Financial Services website: www.dellfinancialservices.com	
	Financial Services (lease/loans)	toll-free: 1-877-577-3355
	Financial Services (Dell Preferred Accounts [DPA])	toll-free: 1-800-283-2210
	Business	
	Customer Service and Technical Support	toll-free: 1-800-822-8965
	Employee Purchase Program (EPP) Customers	toll-free: 1-800-695-8133
	Printers and Projectors Technical Support	toll-free: 1-877-459-7298
	Public (government, education, and healthcare)	
	Customer Service and Technical Support	toll-free: 1-800-456-3355
	Employee Purchase Program (EPP) Customers	toll-free: 1-800-234-1490
	Dell Sales	toll-free: 1-800-289-3355 or toll-free: 1-800-879-3355
	Dell Outlet Store (Dell refurbished computers)	toll-free: 1-888-798-7561
	Software and Peripherals Sales	toll-free: 1-800-671-3355
	Spare Parts Sales	toll-free: 1-800-357-3355
	Extended Service and Warranty Sales	toll-free: 1-800-247-4618
	Fax	toll-free: 1-800-727-8320
	Dell Services for the Deaf, Hard-of-Hearing, or Speech-Impaired	toll-free: 1-877-DELLTY (1-877-335-5889)
U.S. Virgin Islands	General Support	1-877-673-3355
Venezuela	General Support	8001-3605

Index

A

audio. See *sound*

B

battery

- problems, 27
- replacing, 89

BIOS, 97

boot sequence, 102

- changing, 102-103
- option settings, 102

booting

- to a USB device, 102

C

cards

- installing, 67
- PCI Express, 67
- removing, 70
- slots, 66
- types supported, 66

CD/DVD drive

- problems, 28

CD/DVD-RW drive

- problems, 28

CDs

- copying, 21
- playing, 18

Check Disk, 29

CMOS settings

- clearing, 104

computer

- cleaning, 105
- crashes, 32-33
- internal parts, 61
- restore to previous operating state, 49-50
- stops responding, 32-33

copying CDs and DVDs, 21

cover

- closing, 91
- opening, 59

D

Dell

- contacting, 107-108
- Dell Diagnostics, 46
- support policy, 106
- support site, 10

Dell Premier Support

- website, 10

diagnostic lights, 43

diagnostics

- Dell, 46
- lights, 43

display. See *monitor*

documentation

- End User License Agreement, 9
- ergonomics, 9
- online, 10
- Product Information Guide, 9
- regulatory, 9
- safety, 9
- Setup Diagram, 9
- warranty, 9

drivers

- about, 47
- identifying, 47

drives

- hard drive, 73
- installing floppy, 85
- installing hard drive, 75
- problems, 27
- removing floppy, 83
- removing hard drive, 73
- serial ATA, 73

DVD drive

- problems, 28

DVDs

- copying, 21
- playing, 18

E

e-mail

- problems, 29

End User License Agreement, 9
ergonomics information, 9
error messages
 diagnostic lights, 43

F

floppy drive
 installing, 85
 removing, 83

H

hard drive
 installing, 75
 problems, 29
 removing, 73
hardware
 Dell Diagnostics, 46
Hardware Troubleshooter, 49
Help and Support Center, 11
hibernate mode, 24-25
Hyper-Threading, 25

I

IEEE 1394
 problems, 31
installing parts
 before you begin, 53
 recommended tools, 53
 turning off your computer, 53

Internet
 connection, about, 17
 connection, options, 17
 connection, setting up, 17
 problems, 29

K

keyboard
 problems, 32

L

labels
 Microsoft Windows, 10
 Service Tag, 10
lights
 back of computer, 43
 diagnostic, 43

M

media card reader
 installing, 81
 problems, 31
 removing, 80
 using, 14
memory
 4-GB configurations, 64
 DDR2 overview, 63
 installation guidelines, 63
 installing, 64
 problems, 34
 removing, 66
 type supported, 63

messages
 error, 30
Microsoft Windows label, 10
modem
 adding, 87
 problems, 29
monitor
 blank, 40
 clone mode, 16
 connect TV, 15
 display settings, 16
 extended desktop mode, 16
 hard to read, 41
 problems, 40
motherboard. See *system board*
mouse
 problems, 35

N

network
 Network Setup Wizard, 17
 problems, 36
 setting up, 16
Network Setup Wizard, 17

O

operating system
 restoring, 49-50

P

- password
 - clearing, 103
 - jumper, 103
- PC Restore, 49-50
- PCI Express cards
 - installing, 67
 - removing, 70
- playing
 - CDs, 18
 - DVDs, 18
- power
 - conserving, 23
 - hibernate mode, 24-25
 - managing, 23
 - options, 24
 - options, advanced, 25
 - options, hibernate, 25
 - options, schemes, 24
 - problems, 36
 - standby mode, 23
- power light
 - conditions, 36
- printer
 - cable, 13
 - connecting, 13
 - problems, 37
 - setting up, 13
 - USB, 14
- problems
 - battery, 27
 - blue screen, 33
 - CD drive, 28
 - CD/DVD-RW drive, 28
 - computer crashes, 32-33

- problems (*continued*)
 - computer stops
 - responding, 32-33
 - Dell Diagnostics, 46
 - diagnostic lights, 43
 - drives, 27
 - DVD drive, 28
 - e-mail, 29
 - error messages, 30
 - general, 32
 - hard drive, 29
 - IEEE 1394, 31
 - Internet, 29
 - keyboard, 32
 - media card reader, 31
 - memory, 34
 - modem, 29
 - monitor is blank, 40
 - monitor is hard to read, 41
 - mouse, 35
 - network, 36
 - power, 36
 - power light conditions, 36
 - printer, 37
 - program crashes, 33
 - program stops responding, 33
 - programs and Windows
 - compatibility, 33
 - restore to previous operating state, 49-50
 - scanner, 38
 - screen is blank, 40
 - screen is hard to read, 41
 - software, 33-34
 - sound and speakers, 39
 - technical support policy, 106
 - troubleshooting tips, 27
 - video and monitor, 40
 - volume adjusting, 39

Product Information Guide, 9

Program Compatibility Wizard, 33

R

regulatory information, 9

restoring

- Windows XP, 49-50

S

safety instructions, 9

SATA. See *serial ATA*

scanner

- problems, 38

screen. See *monitor*

serial ATA, 73

Service Tag, 10

settings

- system setup, 97

Setup Diagram, 9

software

- Hyper-Threading, 25
- problems, 33-34

sound

- problems, 39
- volume, 39

speaker

- problems, 39
- volume, 39

specifications

- audio, 94
- computer information, 93

specifications (*continued*)

- connectors, 95
 - controls and lights, 96
 - drives, 94
 - environmental, 97
 - expansion bus, 94
 - memory, 93
 - physical, 97
 - power, 96
 - processor, 93
 - technical, 93
 - video, 94
- standby mode, 23
- support
- contacting Dell, 107-108
 - policy, 106
- system board, 62
- System Restore, 49-50
- system setup
- entering, 98
 - options, 99
 - screens, 98

T

- technical support
- policy, 106
- troubleshooting
- Dell Diagnostics, 46
 - diagnostic lights, 43
 - Hardware Troubleshooter, 49
 - Help and Support Center, 11
 - restore to previous operating state, 49-50
 - tips, 27

TV

- connect to computer, 15

U

USB

- booting to devices, 102

V

video

- problems, 40

volume

- adjusting, 39

W

- warranty information, 9

Windows XP

- Device Driver Rollback, 48
- Hardware Troubleshooter, 49
- Help and Support Center, 11
- Hyper-Threading, 25
- Network Setup Wizard, 17
- Program Compatibility Wizard, 33
- restoring, 49-50
- scanner, 39
- System Restore, 49-50

wizards

- Network Setup Wizard, 17
- Program Compatibility Wizard, 33