

COMPAQ

Maintenance and Service Guide

Compaq Presario V2600 Notebook PC

Document Part Number: 408525-001

March 2006

This guide is a troubleshooting reference used for maintaining and servicing the computer. It provides comprehensive information on identifying computer features, components, and spare parts; troubleshooting computer problems; and performing computer disassembly procedures.

© Copyright 2006 Hewlett-Packard Development Company, L.P.

Microsoft and Windows are U.S. registered trademarks of Microsoft Corporation. Intel is a trademark or registered trademark of Intel Corporation or its subsidiaries in the United States and other countries. Bluetooth is a trademark owned by its proprietor and used by Hewlett-Packard Company under license. SD Logo is a trademark of its proprietor.

The information contained herein is subject to change without notice. The only warranties for HP products and services are set forth in the express warranty statements accompanying such products and services. Nothing herein should be construed as constituting an additional warranty. HP shall not be liable for technical or editorial errors or omissions contained herein.

Maintenance and Service Guide
Compaq Presario V2600 Notebook PC
First Edition: March 2006
Document Part Number: 408525-001

Contents

1 Product Description

1.1 Features	1-2
1.2 Resetting the Computer.	1-4
1.3 Power Management.	1-5
1.4 External Components	1-6
1.5 Design Overview.	1-20

2 Troubleshooting

2.1 Computer Setup.	2-1
Accessing Computer Setup.	2-2
Computer Setup Defaults	2-2
Selecting from the File Menu	2-3
Selecting from the Security Menu	2-4
Selecting from the Tools Menu.	2-5
Selecting from the Advanced Menu	2-6
2.2 Troubleshooting Flowcharts	2-7

3 Illustrated Parts Catalog

3.1 Serial Number Location	3-1
3.2 Computer Major Components	3-2
3.3 Display Assembly Components	3-12
3.4 Mass Storage Devices	3-14
3.5 Plastics Kit	3-16
3.6 Miscellaneous	3-17
3.7 Sequential Part Number Listing	3-19

4 Removal and Replacement Preliminaries

4.1 Tools Required	4-1
4.2 Service Considerations	4-1
Plastic Parts	4-2
Cables and Connectors	4-2
4.3 Preventing Damage to Removable Drives	4-3
4.4 Preventing Electrostatic Damage	4-4
4.5 Packaging and Transporting Precautions	4-5
4.6 Workstation Precautions	4-6
4.7 Grounding Equipment and Methods	4-7

5 Removal and Replacement Procedures

5.1	Serial Number	5-2
5.2	Disassembly Sequence Chart	5-3
5.3	Preparing the Computer for Disassembly	5-4
5.4	Hard Drive	5-6
5.5	Computer Feet	5-10
5.6	Memory Module	5-10
5.7	Mini Card Module	5-13
5.8	Optical Drive	5-17
5.9	Switch Cover	5-20
5.10	Keyboard	5-23
5.11	Display Assembly	5-26
5.12	Base Enclosure	5-37
5.13	USB/S-Video Board	5-40
5.14	Bluetooth Module	5-42
5.15	Speaker Assembly	5-44
5.16	RTC Battery	5-46
5.17	Fan/Heat Sink Assembly	5-48
5.18	Processor	5-50
5.19	System Board	5-52
5.20	LED Board	5-58
5.21	ExpressCard Assembly	5-60

6 Specifications

A Connector Pin Assignments

B Power Cord Set Requirements

C Screw Listing

D Display Component Recycling

Index

1

Product Description

The Compaq Presario V2600 Notebook PC offers advanced modularity, Intel® Core Duo and Core Solo processors, and extensive multimedia support.



Compaq Presario V2600 Notebook PC

1.1 Features

- The following processors are available, varying by computer model:
 - ❑ Intel Core Duo T2500 (2.00-GHz)
 - ❑ Intel Core Duo T2400 (1.83-GHz)
 - ❑ Intel Core Duo T2300 (1.66-GHz)
 - ❑ Intel Core Solo T1300 (1.66-GHz)
- 14.0-inch WXGA (1280 × 768) TFT display with over 16.7 million colors, varying by computer model
- 100-, 80-, 60-, or 40-GB high-capacity hard drive, varying by computer model
- 256-MB DDR synchronous DRAM (SDRAM) at 533 MHz, expandable to 2.0 GB on models with Intel Core Duo processors and 1.0 GB on models with Intel Core Solo processors
- Microsoft® Windows® XP Home Edition or Windows XP Professional, or Free DOS, varying by computer model
- Full-size Windows keyboard with embedded numeric keypad
- TouchPad pointing device with on/off button and dedicated two-way scroll region
- Integrated 10/100 BASE-T Ethernet local area network (LAN) network interface card (NIC) with RJ-45 jack
- Integrated high-speed 56K modem with RJ-11 jack
- Integrated wireless support for Mini Card IEEE 802.11b and 802.11b/g WLAN device

- Support for ExpressCards
- External 65-watt AC adapter with 3-wire power cord
- 6-cell or 12-cell Li-Ion battery pack
- Stereo speakers with volume up and down buttons
- Support for the following optical drives:
 - ❑ 8X Max DVD+RW/R and CD-RW Combo Drive
 - ❑ 4X Max DVD+RW/R and CD-RW Combo Drive
 - ❑ 8X Max DVD-ROM Drive
 - ❑ 24X Max DVD/CD-RW Combo Drive
- Connectors:
 - ❑ External monitor
 - ❑ Universal Serial Bus (USB) v. 2.0
 - ❑ RJ-11 (modem)
 - ❑ RJ-45 (network)
 - ❑ Audio-out (headphone)
 - ❑ Audio-in (microphone)
 - ❑ Power
 - ❑ IEEE 1394 digital (select models only)
 - ❑ S-Video-out (select models only)
 - ❑ Parallel
 - ❑ Serial
 - ❑ Docking (select models only)
 - ❑ Memory Reader (select models only)

1.2 Resetting the Computer

If the computer you are servicing has an unknown password, follow these steps to clear the password. These steps also clear CMOS:

1. Prepare the computer for disassembly (refer to [Section 5.3, “Preparing the Computer for Disassembly,”](#) for more information).
2. Remove the real-time clock (RTC) battery (refer to [Section 5.16, “RTC Battery,”](#) for more information).
3. Wait approximately 5 minutes.
4. Replace the RTC battery and reassemble the computer.
5. Connect AC power to the computer. Do not reinsert any battery packs at this time.
6. Turn on the computer.

All passwords and all CMOS settings have been cleared.

1.3 Power Management

The computer comes with power management features that extend battery operating time and conserve power. The computer supports the following power management features:

- Standby
- Hibernation
- Setting customization by the user
- Hotkeys for setting the level of performance
- Battery calibration
- Lid switch standby/resume
- Power/standby button
- Advanced Configuration and Power Management (ACPM) compliance

1.4 External Components

The external components on the front of the computer are shown below and described in Table 1-1.



Front Components

Table 1-1
Front Components

Item	Component	Function
1	Speakers (2)	Produce stereo sound.
2	Wireless light (select models only)	On: An integrated wireless device is hardware enabled.
3	Power light	<ul style="list-style-type: none"> ■ On: Computer is turned on. ■ Blinking: Computer is in standby. ■ Off: Computer is off.
4	Drive light	On or blinking: The internal hard drive or an optical drive is being accessed.
5	Battery light	<ul style="list-style-type: none"> ■ Amber: The battery pack is charging. ■ Green: The battery pack is fully charged. ■ Off: The battery pack is discharging or not inserted.
6	Display release button	Opens the computer.
7	Audio-in (microphone) jack	Connects an optional monaural (single sound channel) microphone.
8	Audio-out (headphone) jack	Connect optional headphones or powered stereo speakers. Also connect the audio function of an audio/video device such as a television or VCR.

The external components on the right side of the computer are shown below and described in Table 1-2.



Right-Side Components

Table 1-2
Right-Side Components

Item	Component	Function
1	USB connectors (2)	Connect an optional USB device.
2	Memory Reader (select models only)	In Windows, supports digital cards.
3	1394 port (select models only)	Connects an optional 1394 device such as a scanner, digital camera, or digital camcorder.
4	Memory Reader light (select models only)	On: A digital card is being accessed.
5	Optical drive	Supports an optical disc.
6	S-Video-out jack (select models only)	Connects an optional S-Video device, such as a television, VCR, camcorder, projector, or video capture card.

The external components on the rear and left side of the computer are shown below and described in Table 1-3.



Rear and Left-Side Components

Table 1-3
Rear and Left-Side Components

Item	Component	Function
1	Exhaust vent	Provide airflow to cool internal components.  To prevent overheating, do not obstruct vents. Use the computer only on a flat, hard surface. Do not allow a hard surface, such as a printer, or a soft surface, such as pillows, thick rugs or clothing, to block airflow.
2	Power connector	Connects an AC adapter cable.
3	External monitor port	Connects an optional VGA external monitor or projector.
4	Expansion port 2	Connects the computer to an optional expansion product or docking device.
5	RJ-45 (network) jack	Connects an optional network cable.
6	RJ-11 (modem) jack	Connects the modem cable.
7	USB connector	Connects an optional USB device.
8	ExpressCard slot	Supports an optional ExpressCard device.
9	Security cable slot	Attaches an optional security cable to the computer.

The computer keyboard components on the computer are shown below and described in Table 1-4.

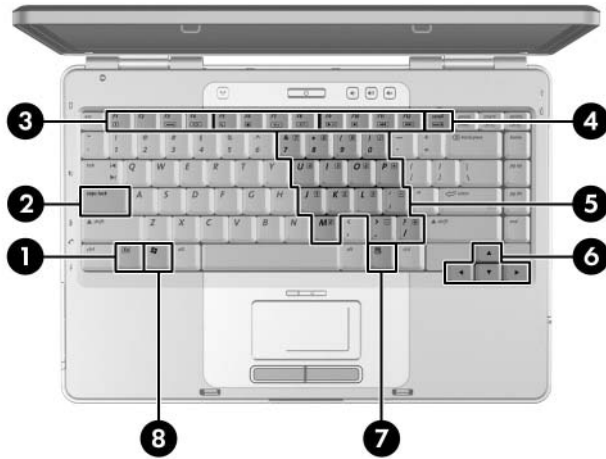

Keyboard Components

Table 1-4
Keyboard Components

Item	Component	Function
1	fn key	Combines with other keys to perform system tasks. For example, pressing fn+f7 decreases screen brightness.
2	caps lock key	Enables caps lock and turns on the caps lock light.
3	f1 to f12 keys (12)	Perform system and application tasks. When combined with the fn key, several keys and buttons perform additional tasks as hotkeys.
4	num lock key	Enables numeric lock, turns on the embedded numeric keypad, and turns on the num lock light.
5	Keypad keys (15)	In Windows, can be used like the keys on an external numeric keypad.
6	Arrows keys	Move the cursor around the screen.
7	Windows applications key	In Windows, displays a shortcut menu for items beneath the pointer.
8	Windows logo key	In Windows, displays the Windows Start menu.

The computer top components on the computer are shown below and described in Table 1-5.



Top Components, Part 1

Table 1-5
Top Components, Part 1

Item	Component	Function
1	Caps lock light	On: Caps lock is on.
2	Display switch	If the computer is closed while on, turns off the display.

Table 1-5
Top Components, Part 1 (Continued)

Item	Component	Function
3	Wireless button	Enables/disables an internal wireless device.
	Wireless light	On: an integrated wireless device is hardware enabled.
4	Power button	When the computer is <ul style="list-style-type: none"> ■ Off, press to turn on the computer. ■ On, briefly press to initiate Hibernation. ■ In Standby, briefly press to resume from Standby. ■ In Hibernation, briefly press to restore from Hibernation.
	Power light	<ul style="list-style-type: none"> ■ On: Computer is turned on. ■ Blinking: Computer is in standby. ■ Off: Computer is off.
5	Volume down button	Decreases system volume.
6	Volume up button	Increases system volume.
7	Volume mute button	Mutes or restores volume.
	Mute light	On: Volume is muted.
8	Num lock light	On: Num lock or the internal keypad is on.

The computer top components on the computer are shown below and described in Table 1-6.



Top Components, Part 2

Table 1-6
Top Components, Part 2

Item	Component	Function
1	TouchPad horizontal scrolling region	Scrolls toward left side or right side.
2	TouchPad	Moves the pointer.
3	TouchPad light	On: TouchPad is enabled.
4	TouchPad on/off button	Enables/disables the TouchPad.
5	TouchPad vertical scroll region	Scrolls upward or downward.
6	Left and right TouchPad buttons	Function like the left and right buttons on an external mouse.

The external components on the bottom of the computer are shown below and described in Table 1-7.

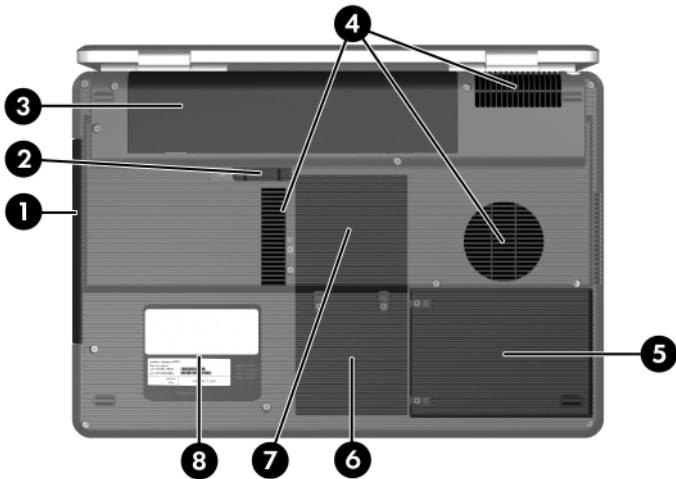

Bottom Components

Table 1-7
Bottom Components

Item	Component	Function
1	Optical drive	Supports an optical disc.
2	Battery pack release latch	Releases a battery pack from the battery bay.
3	Battery pack	Holds a battery pack.

Table 1-7
Bottom Components (Continued)

Item	Component	Function
4	Exhaust vents (4)	<p>Provide airflow to cool internal components.</p> <p>△ To prevent overheating, do not obstruct vents. Use the computer only on a flat, hard surface. Do not allow a hard surface, such as a printer, or a soft surface, such as pillows, thick rugs or clothing, to block airflow.</p>
5	Hard drive bay	Holds the internal hard drive.
6	Mini Card compartment	<p>Holds an optional wireless LAN device.</p> <p>△ To prevent an unresponsive system and the display of a warning message, install only a Mini Card device authorized for use in your computer by the governmental agency that regulates wireless devices in your country. If you install a device and then receive a warning message, remove the device to restore computer functionality. Then contact Customer Care.</p>
7	Memory module compartment	Contains 2 memory slots that support replaceable memory modules. The number of preinstalled memory modules varies by computer model.
8	Label areas (2)	Contain the computer serial number and other applicable regulatory labels.

1.5 Design Overview

This section presents a design overview of key parts and features of the computer. Refer to [Chapter 3, “Illustrated Parts Catalog,”](#) to identify replacement parts, and [Chapter 5, “Removal and Replacement Procedures,”](#) for disassembly steps.

The system board provides the following device connections:

- Memory module
- Mini Card modules
- Hard drive
- Display
- Keyboard and TouchPad
- Audio
- Intel Core Duo and Core Solo processors
- Fan
- ExpressCard



CAUTION: To properly ventilate the computer, allow at least a 7.6-cm (3-inch) clearance on the left and right sides of the computer.

The computer uses an electric fan for ventilation. The fan is controlled by a temperature sensor and is designed to be turned on automatically when high temperature conditions exist. These conditions are affected by high external temperatures, system power consumption, power management/battery conservation configurations, battery fast charging, and software. Exhaust air is displaced through the ventilation grill located on the left side of the computer.

Troubleshooting



WARNING: Only authorized technicians trained by HP should repair this equipment. All troubleshooting and repair procedures are detailed to allow only subassembly-/module-level repair. Because of the complexity of the individual boards and subassemblies, do not attempt to make repairs at the component level or modifications to any printed wiring board. Improper repairs can create a safety hazard. Any indication of component replacement or printed wiring board modification may void any warranty or exchange allowances.

2.1 Computer Setup

Computer Setup is a preinstalled, ROM-based utility that can be used even when the operating system is not working or will not load. If the operating system is working, the computer restarts the operating system after you exit Computer Setup.



Pointing devices are not supported in Computer Setup; you must use the keyboard to navigate and make selections.

The menu tables later in this chapter provide an overview of Computer Setup options.

Accessing Computer Setup

The information and settings in Computer Setup are accessed from the File, Security, Tools, and Advanced menus.

1. Open Computer Setup by turning on or restarting the computer. Press **f10** while the F10 = Based Setup message is displayed in the lower-left corner of the screen.
 - To change the language, press **f2**.
 - To view navigation information, press **f1**.
 - To return to the Computer Setup menu, press **esc**.
2. Select the **File, Security, Tools, or Advanced** menu.
3. To exit Computer Setup, choose one of the following:
 - To exit without saving any changes, use the arrow keys to select **File > Ignore changes and exit**, and then follow the instructions on the screen.
 - To exit and save all the settings you have entered, use the arrow keys to select **File > Save changes and exit**, and then follow the instructions on the screen.

Your preferences are set when you exit Computer Setup and go into effect when the computer restarts.

Computer Setup Defaults

To restore all settings in Computer Setup to the values that were set at the factory:

1. Open Computer Setup by turning on or restarting the computer. Press **f10** while the F10 = Based Setup message is displayed in the lower-left corner of the screen.
 - To change the language, press **f2**.
 - To view navigation information, press **f1**.
2. Use the arrow keys to select **File > Restore defaults**.
3. Select the **Restore Defaults** check box.

4. To confirm the restoration, press **f10**.
5. Select **File > Save changes and exit**, and then follow the instructions on the screen.

When the computer restarts, the factory settings are restored, and any identification information you have entered is saved.



Selecting from the File Menu

Table 2-1
File Menu

Select	To Do This
System Information	<ul style="list-style-type: none"> ■ View identification information about the computer and any battery packs in the system. ■ View specification information about the processor, memory and cache size, video revision, keyboard controller version, and system ROM.
Save to floppy	Save system configuration settings to a diskette.
Restore to floppy	Restore system configuration settings from a diskette.
Restore defaults	Replace configuration settings in Computer Setup with factory default settings. (Identification information is retained.)
Ignore changes and exit	Cancel changes entered during the current session. Then exit and restart the computer.
Save changes and exit	Save changes entered during the current session. Then exit and restart the computer. The changes you save are to into effect when the computer restarts.

Selecting from the Security Menu

Table 2-2
Security Menu

Select	To Do This
Administrator password	Enter, change, or delete an HP Administrator password.
Power-on password	Enter, change, or delete a power-on password.
Password options	<ul style="list-style-type: none"> ■ Enable/Disable stringent security. ■ Enable/Disable required password on restart.
DriveLock passwords	<p>Enable/disable DriveLock; change a DriveLock user or master password.</p> <p> DriveLock Settings are accessible only when you enter Computer Setup by turning on (not restarting) the computer.</p>
Smart Card Security	<p>Enable/disable power-on support for smart cards.</p> <p> This feature is supported by select smart card readers only.</p>
Embedded Security	<ul style="list-style-type: none"> ■ Enable/Disable the embedded security chip. ■ Restore embedded security chip to factory settings. ■ Enable/Disable power-on authentication support. ■ Enable/Disable automatic DriveLock. ■ Reset power-on authentication credential <p> Embedded Security settings are accessible only if the computer is equipped with an embedded security chip.</p>
Device security	<p>Enable/Disable devices in the system.</p> <p>Enable NIC for inclusion in MultiBoot.</p>
System IDs	Enter user-defined identification values.

Selecting from the Tools Menu

Table 2-3
Tools Menu

Select	To Do This
HDD Self Test options	Run a quick or comprehensive self-test on any hard drive in the system.
Battery Information	View information about any battery packs in the computer.
Memory Check	<ul style="list-style-type: none"> <li data-bbox="426 594 902 646">■ Run a self-test on memory modules in the computer. <li data-bbox="426 659 902 711">■ View information about memory modules installed in the computer.

Selecting from the Advanced Menu

Table 2-4
Advanced Menu

Select	To Do This
Language (or press f2)	Change the Computer Setup language.
Boot options	<ul style="list-style-type: none"> ■ Enable/Disable MultiBoot, which sets a startup sequence that can include most bootable devices and media in the system. ■ Set the boot order.
Device options	<ul style="list-style-type: none"> ■ Swap the functions of the fn key and left ctrl key. ■ Enable/Disable multiple pointing devices at startup. (To set the computer to support only a single, usually nonstandard, pointing device at startup, select Disable.) ■ Enable/Disable USB legacy support for a USB keyboard, mouse, and hub. When USB legacy support is enabled <ul style="list-style-type: none"> <input type="checkbox"/> A USB keyboard, mouse, and hub work even when a Windows operating system is not loaded. <input type="checkbox"/> The computer starts from a bootable hard drive, diskette drive diskette, or CD, CD-RW, or DVD inserted into a drive connected by a USB connector to the computer or to an optional docking device. ■ Select a parallel port mode: EPP (Enhanced Parallel Port), standard, bidirectional, or ECP (Enhanced Capabilities Port). ■ Enable/Disable all settings in the SpeedStep window. (When Disable is selected, the computer runs in Battery Optimized mode.)

2.2 Troubleshooting Flowcharts

Table 2-5
Troubleshooting Flowcharts Overview

Flowchart	Description
2.1	"Flowchart 2.1—Initial Troubleshooting"
2.2	"Flowchart 2.2—No Power, Part 1"
2.3	"Flowchart 2.3—No Power, Part 2"
2.4	"Flowchart 2.4—No Power, Part 3"
2.5	"Flowchart 2.5—No Power, Part 4"
2.6	"Flowchart 2.6—No Video, Part 1"
2.7	"Flowchart 2.7—No Video, Part 2"
2.8	"Flowchart 2.8—Nonfunctioning Docking Device (if applicable)"
2.9	"Flowchart 2.9—No Operating System (OS) Loading"
2.10	"Flowchart 2.10—No OS Loading, Hard Drive, Part 1"
2.11	"Flowchart 2.11—No OS Loading, Hard Drive, Part 2"
2.12	"Flowchart 2.12—No OS Loading, Hard Drive, Part 3"
2.13	"Flowchart 2.13—No OS Loading, Diskette Drive"

Table 2-5
Troubleshooting Flowcharts Overview (*Continued*)

Flowchart	Description
2.14	"Flowchart 2.14—No OS Loading, Optical Drive"
2.15	"Flowchart 2.15—No Audio, Part 1"
2.16	"Flowchart 2.16—No Audio, Part 2"
2.17	"Flowchart 2.17—Nonfunctioning Device"
2.18	"Flowchart 2.18—Nonfunctioning Keyboard"
2.19	"Flowchart 2.19—Nonfunctioning Pointing Device"
2.20	"Flowchart 2.20—No Network/Modem Connection"

Flowchart 2.1 – Initial Troubleshooting

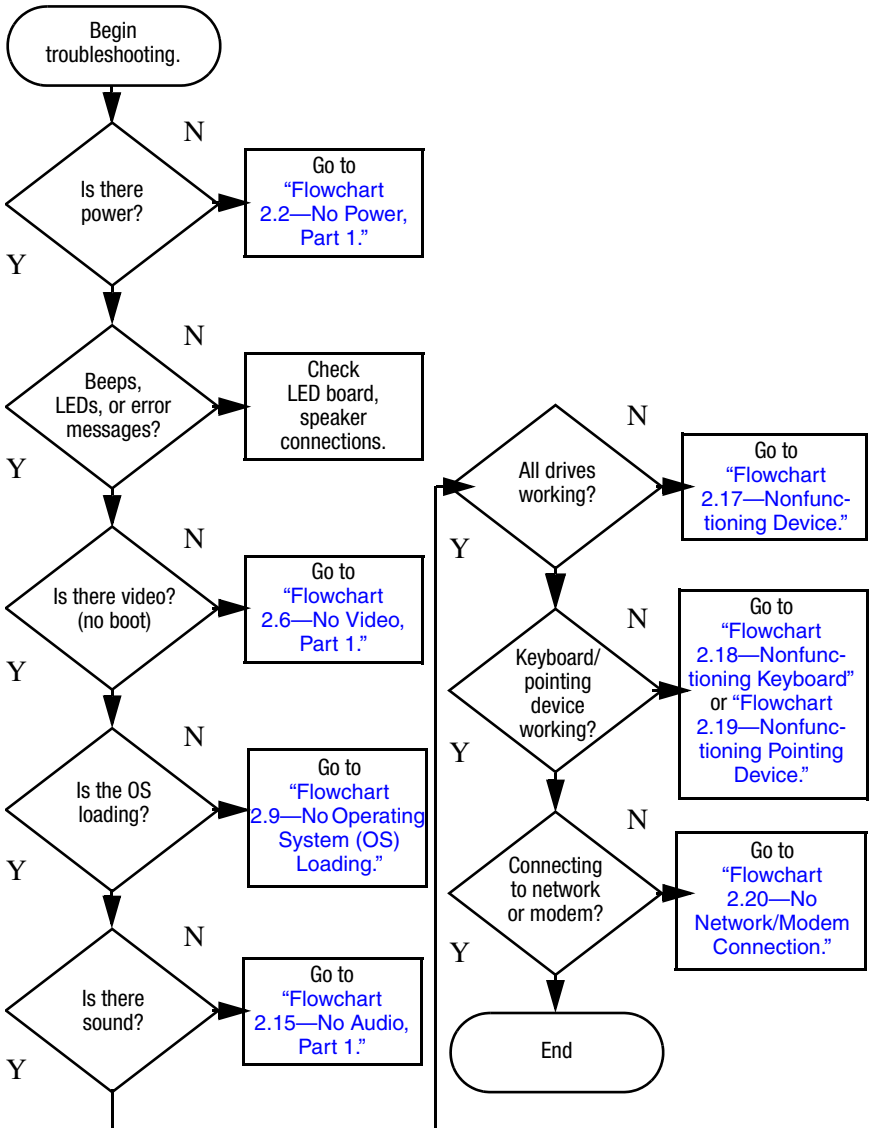

Flowchart 2.2—No Power, Part 1

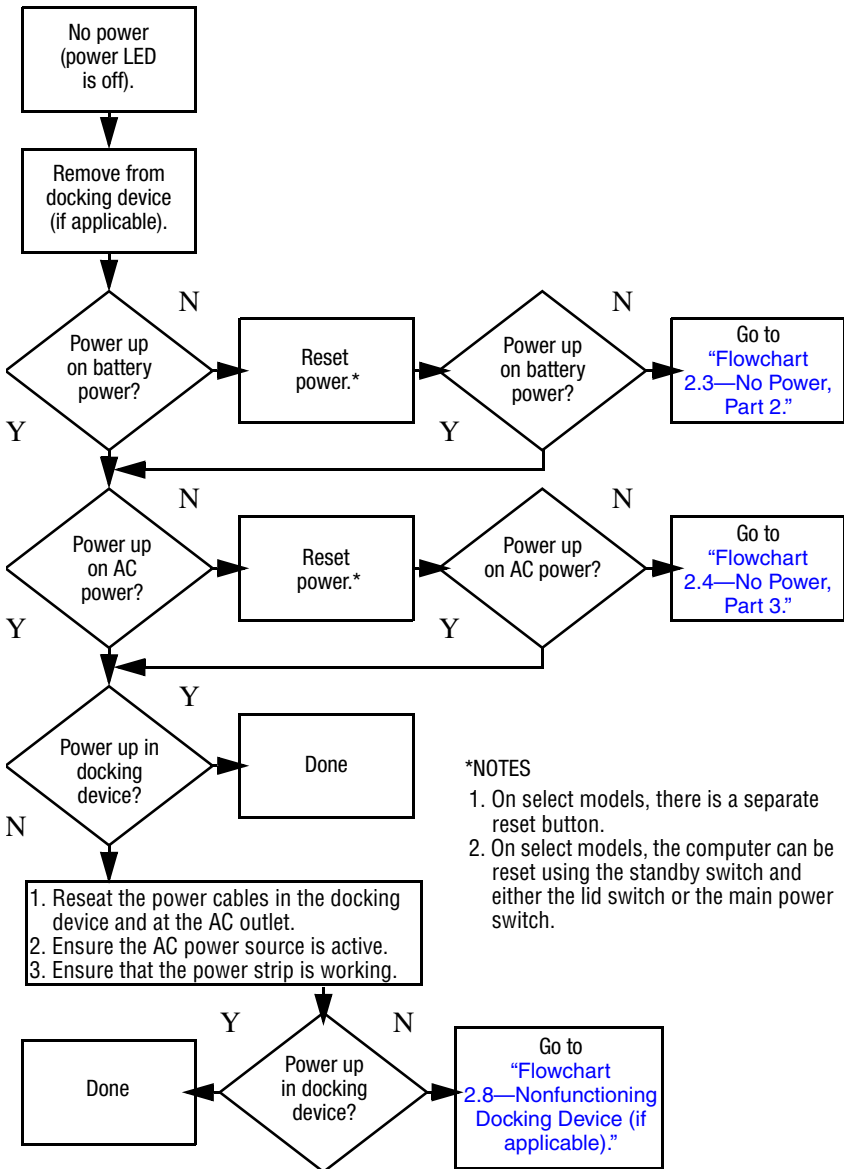

Flowchart 2.3—No Power, Part 2

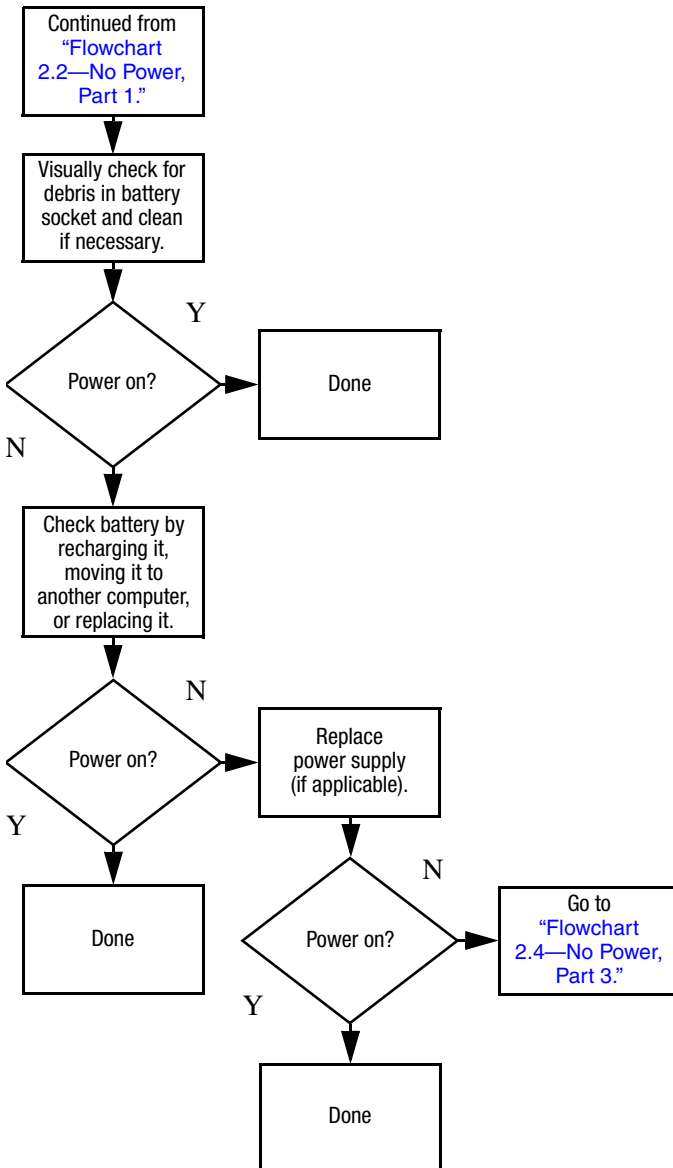

Flowchart 2.4—No Power, Part 3

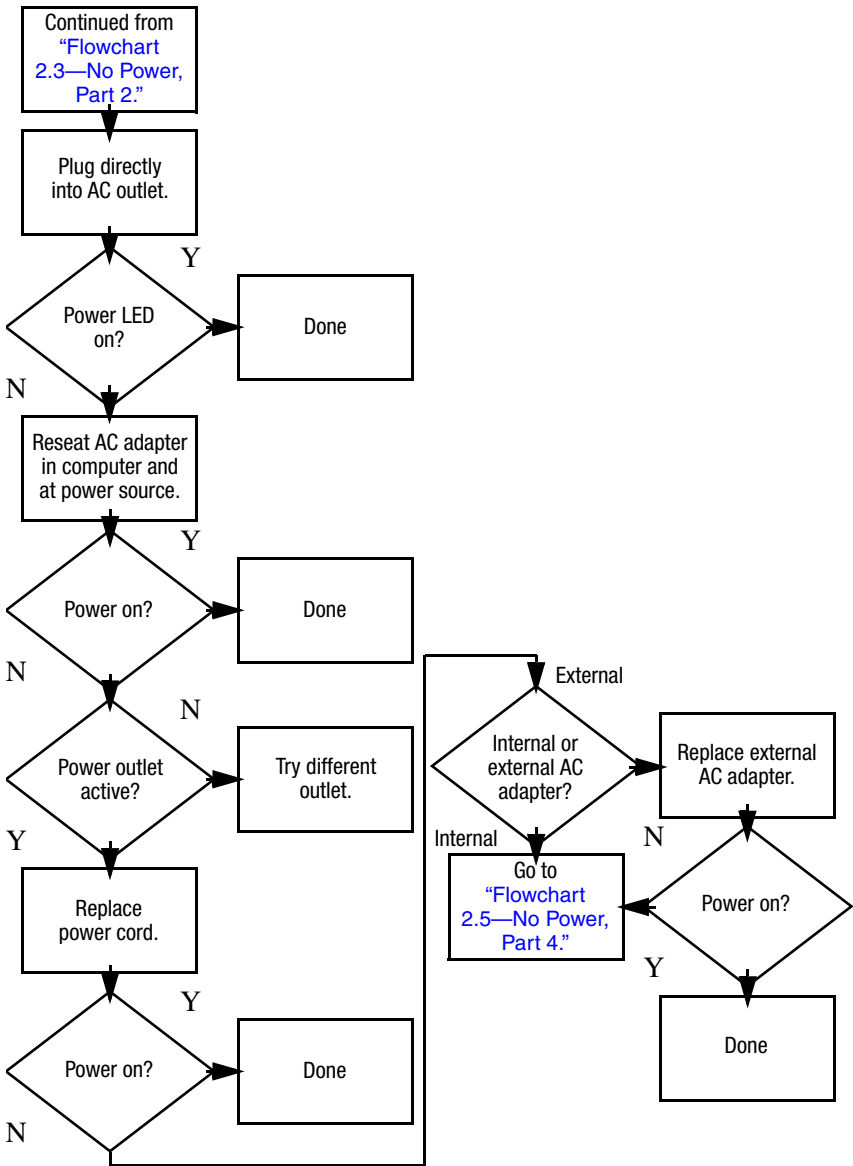

Flowchart 2.5—No Power, Part 4

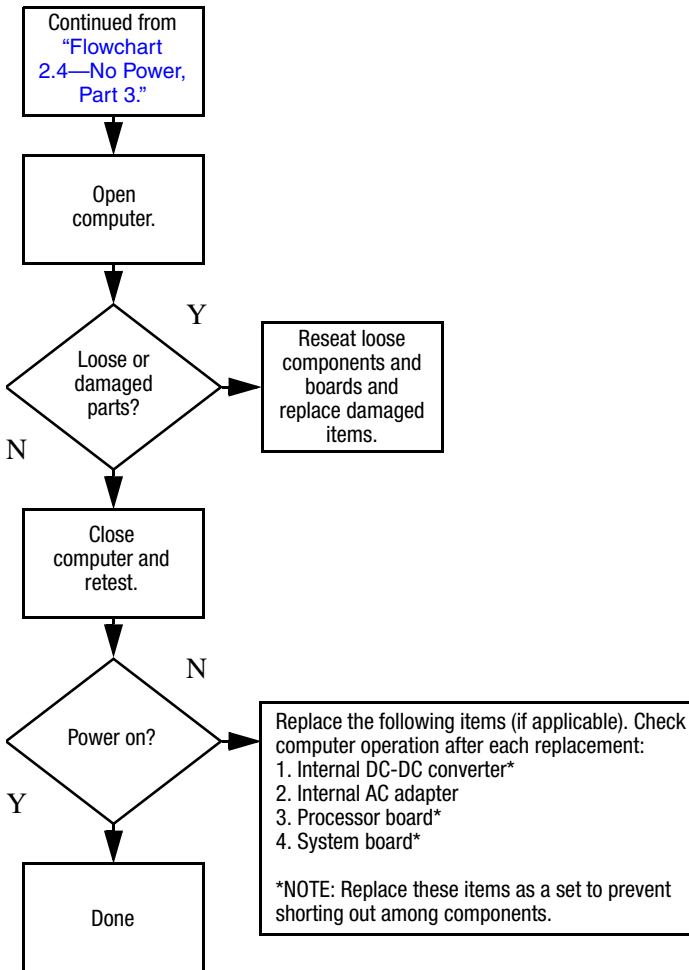

Flowchart 2.6—No Video, Part 1

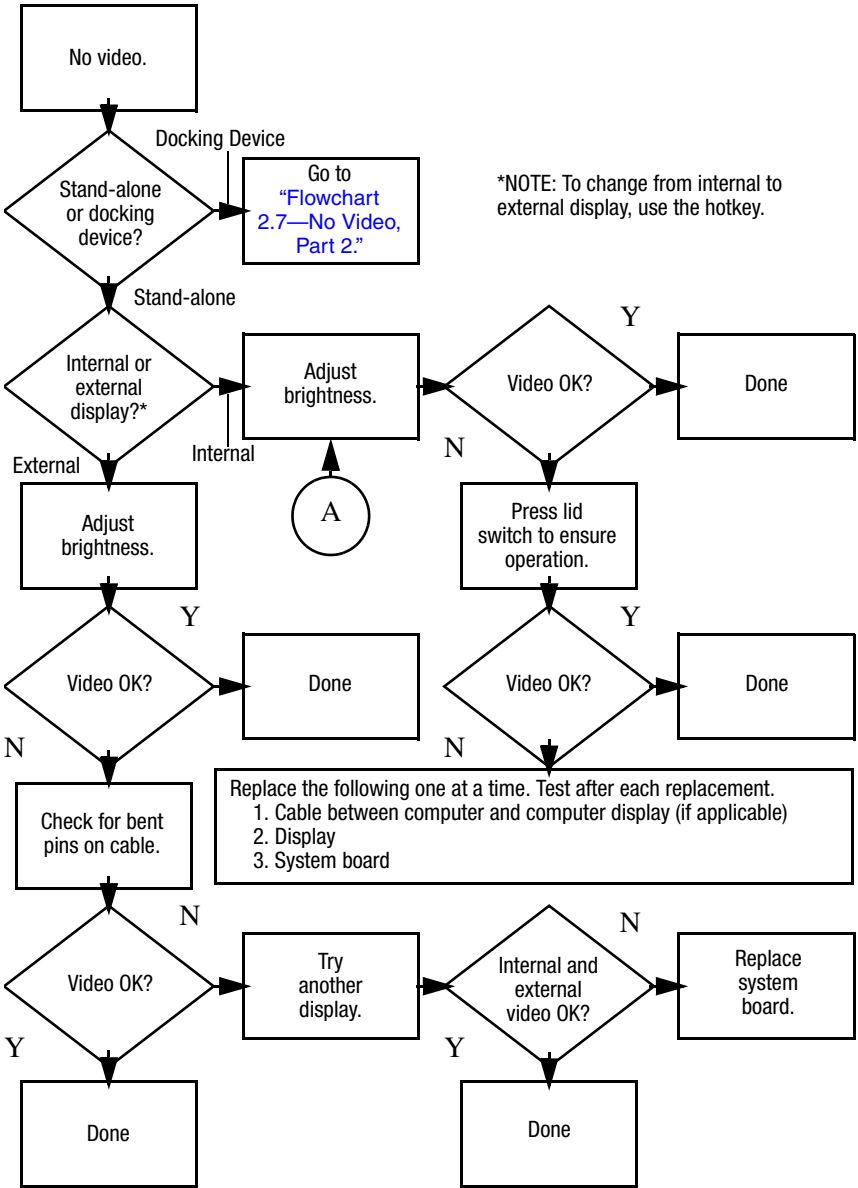

Flowchart 2.7—No Video, Part 2

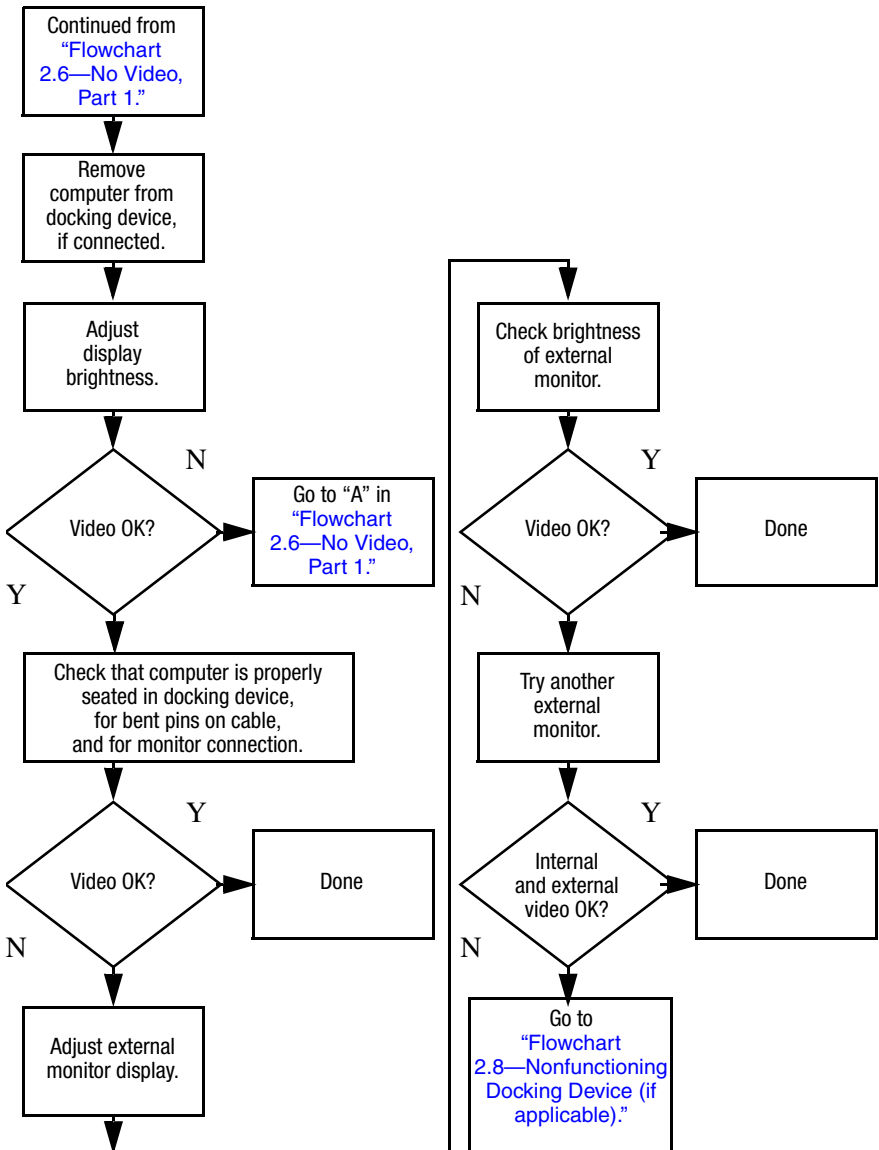

Flowchart 2.8—Nonfunctioning Docking Device (if applicable)

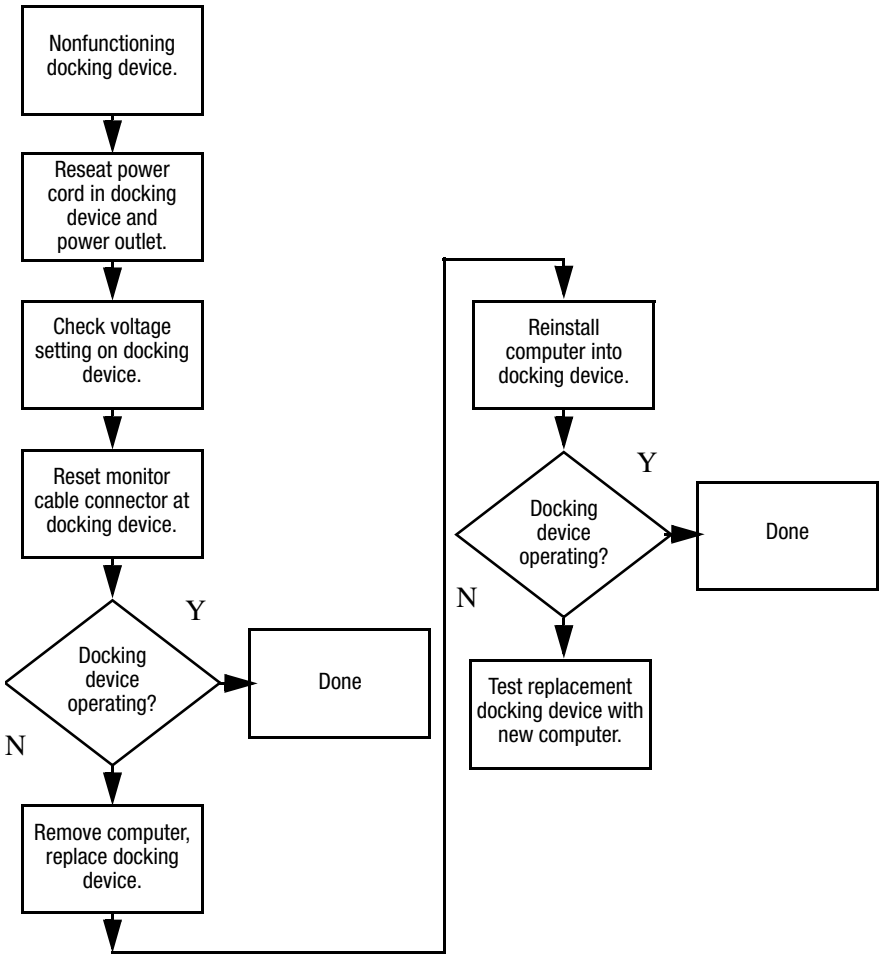

Flowchart 2.9—No Operating System (OS) Loading

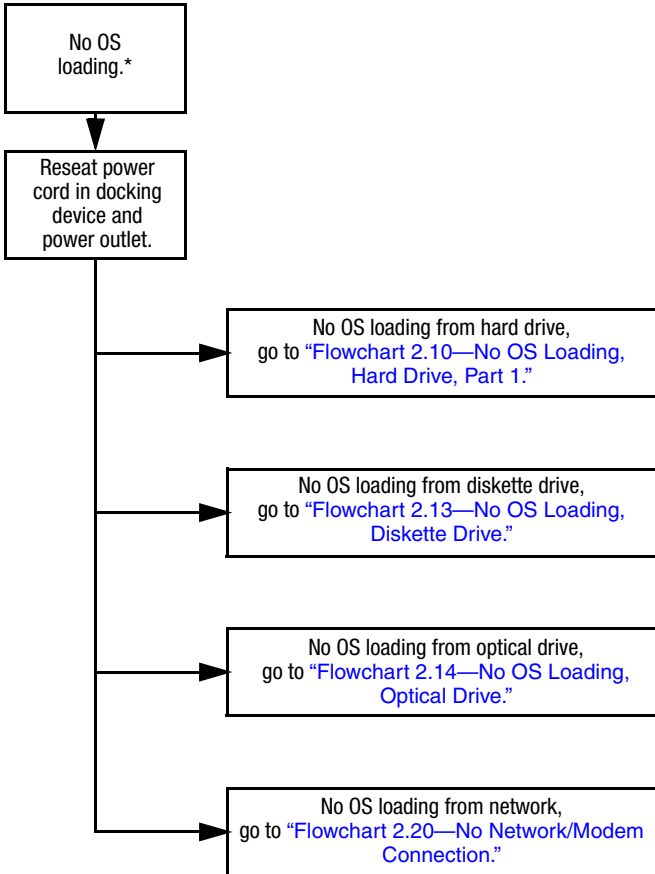

*NOTE: Before beginning troubleshooting, always check cable connections, cable ends, and drives for bent or damaged pins.

Flowchart 2.10—No OS Loading, Hard Drive, Part 1

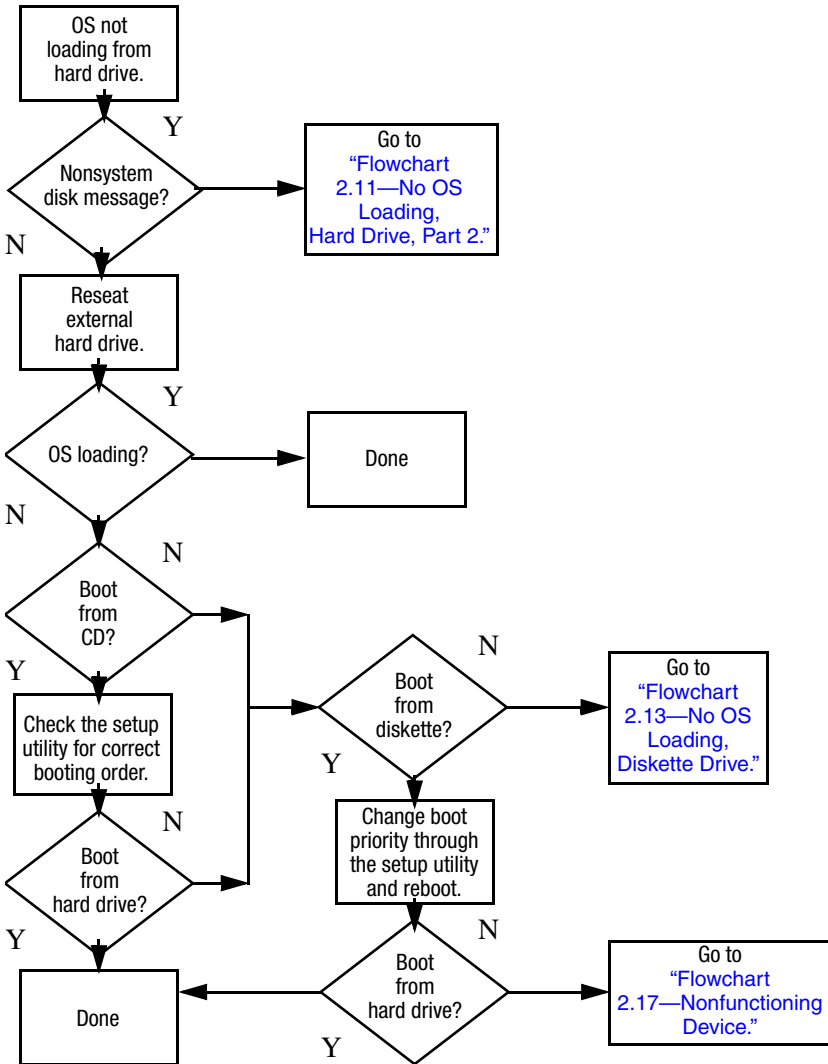

Flowchart 2.11 – No OS Loading, Hard Drive, Part 2

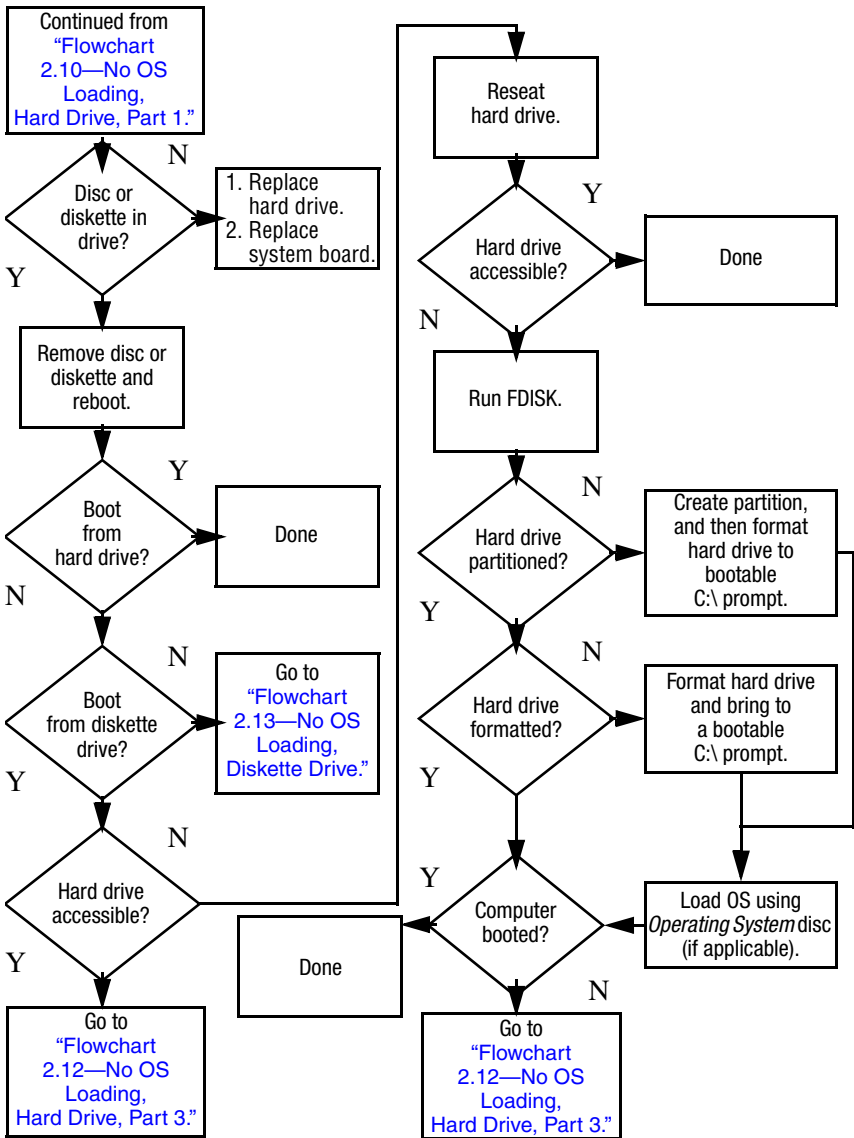

Flowchart 2.12—No OS Loading, Hard Drive, Part 3

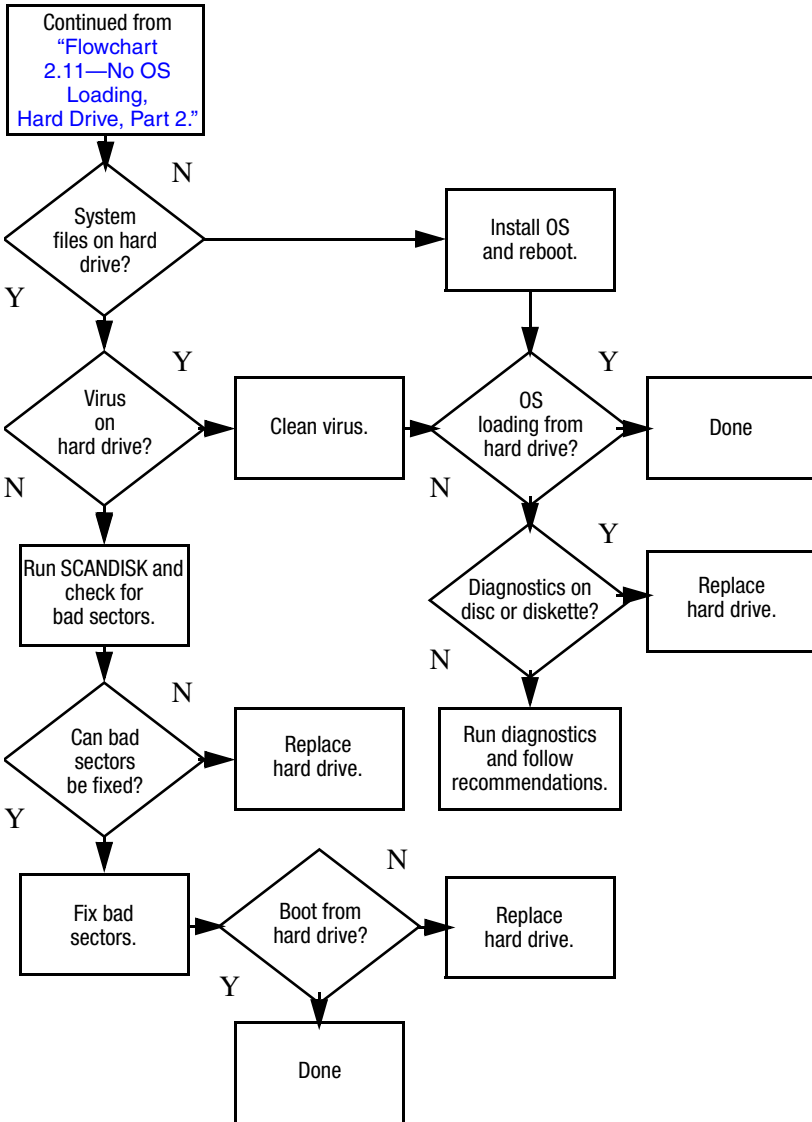

Flowchart 2.13—No OS Loading, Diskette Drive

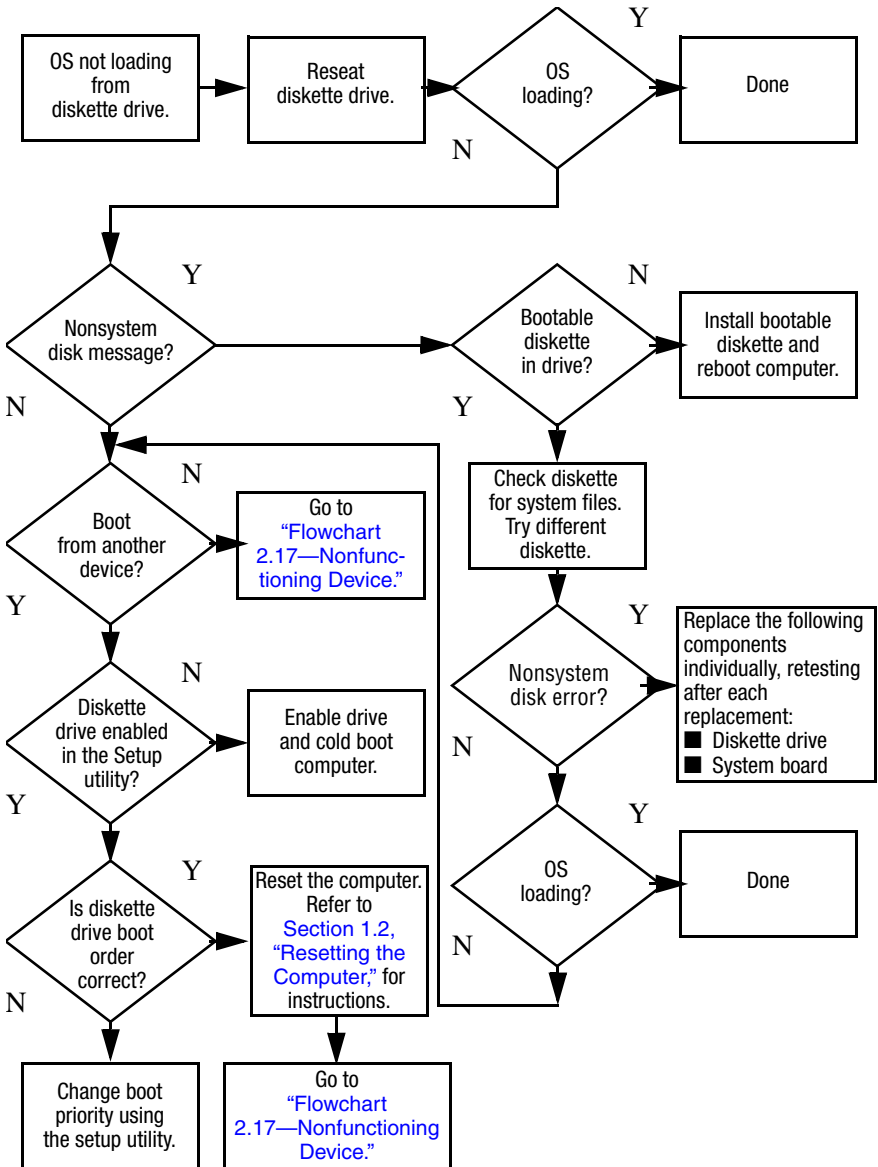

Flowchart 2.14—No OS Loading, Optical Drive

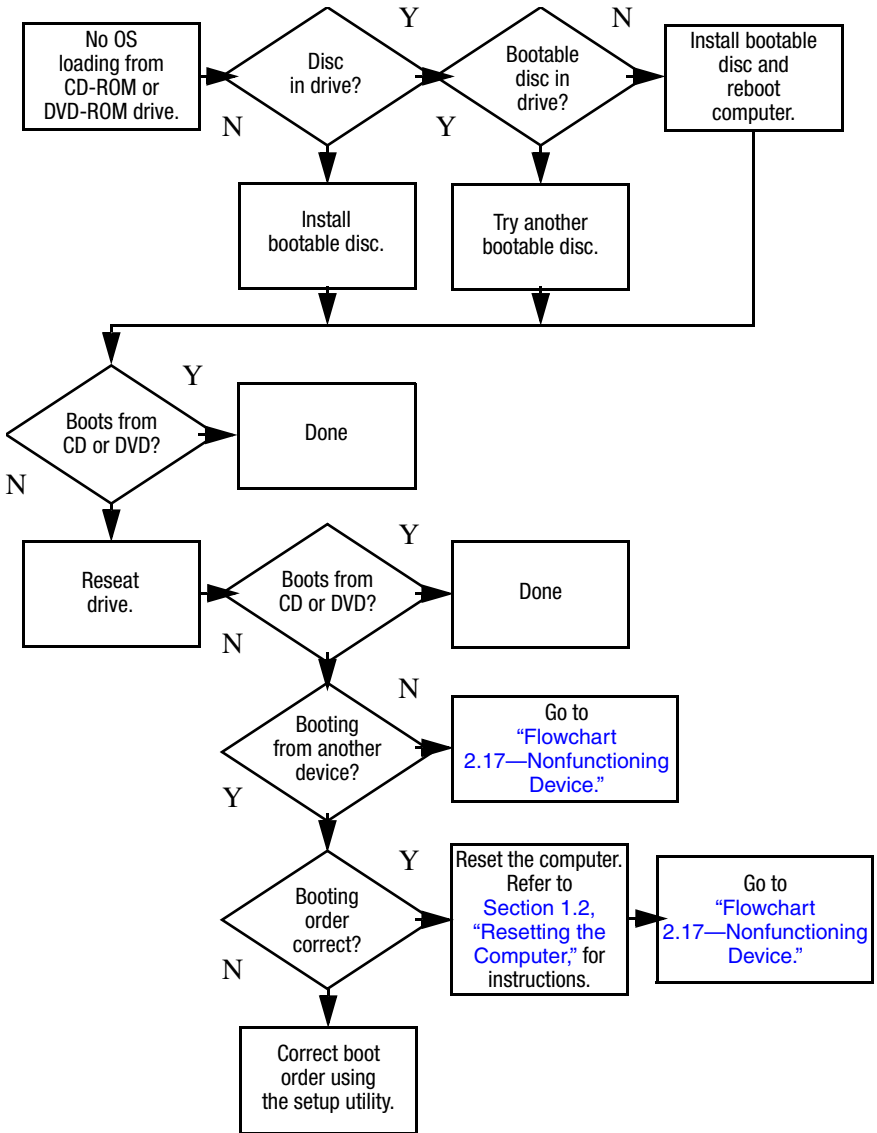

Flowchart 2.15—No Audio, Part 1

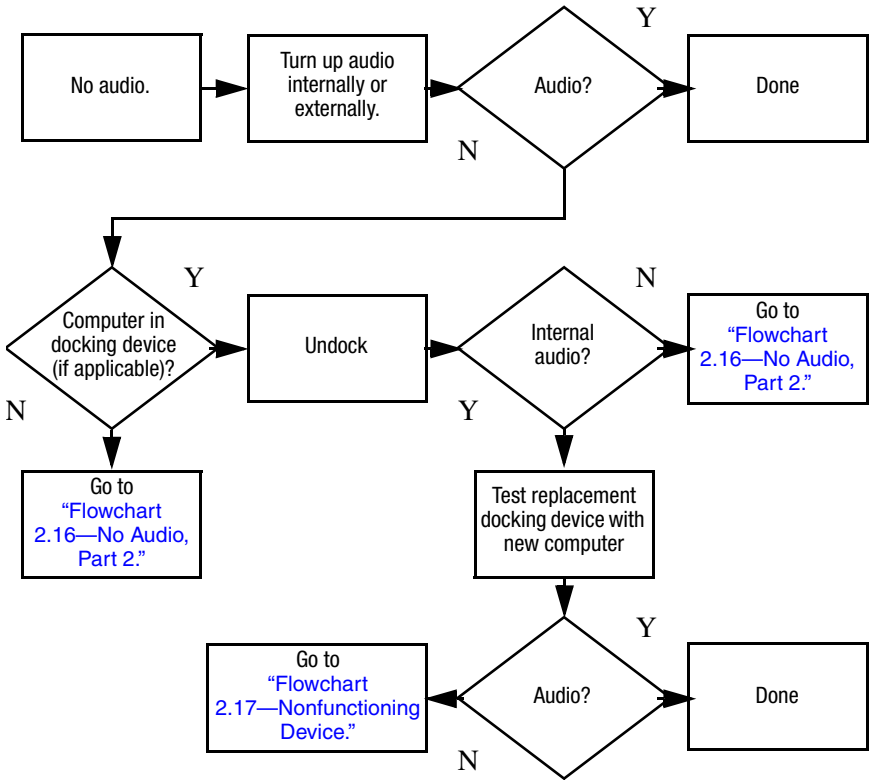

Flowchart 2.16—No Audio, Part 2

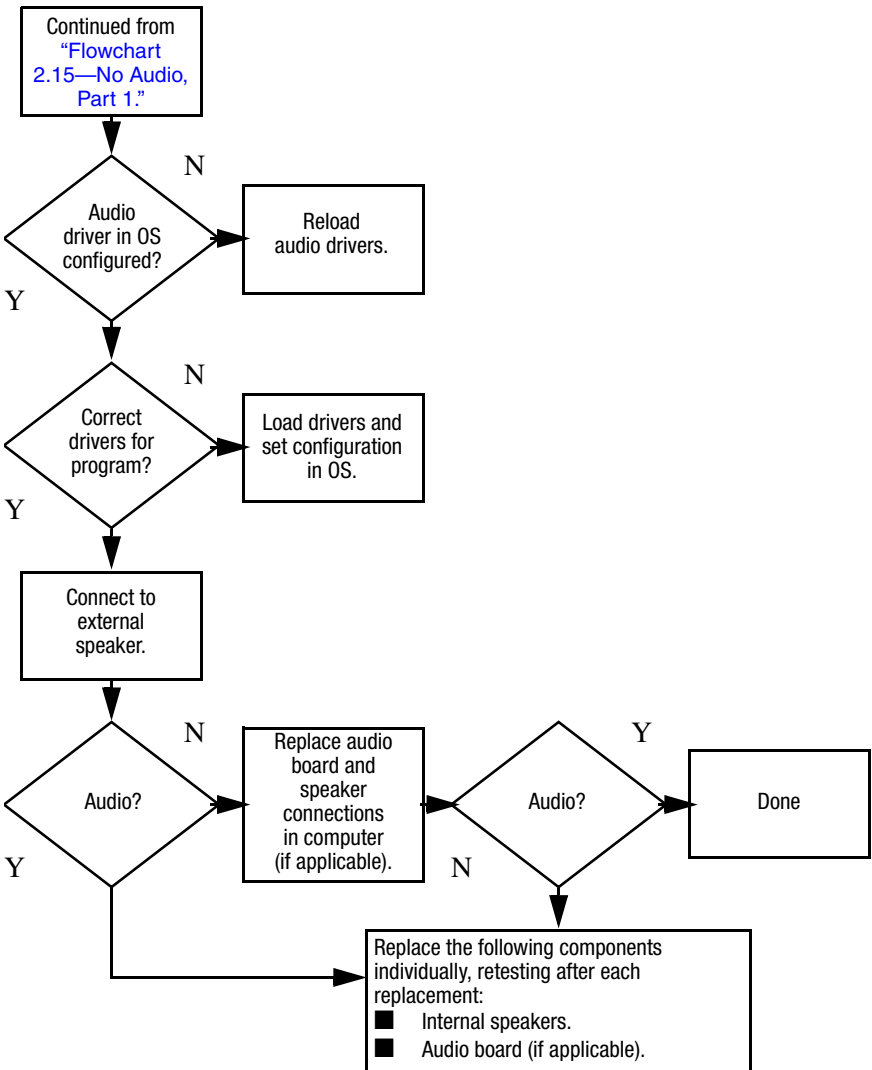

Flowchart 2.17—Nonfunctioning Device

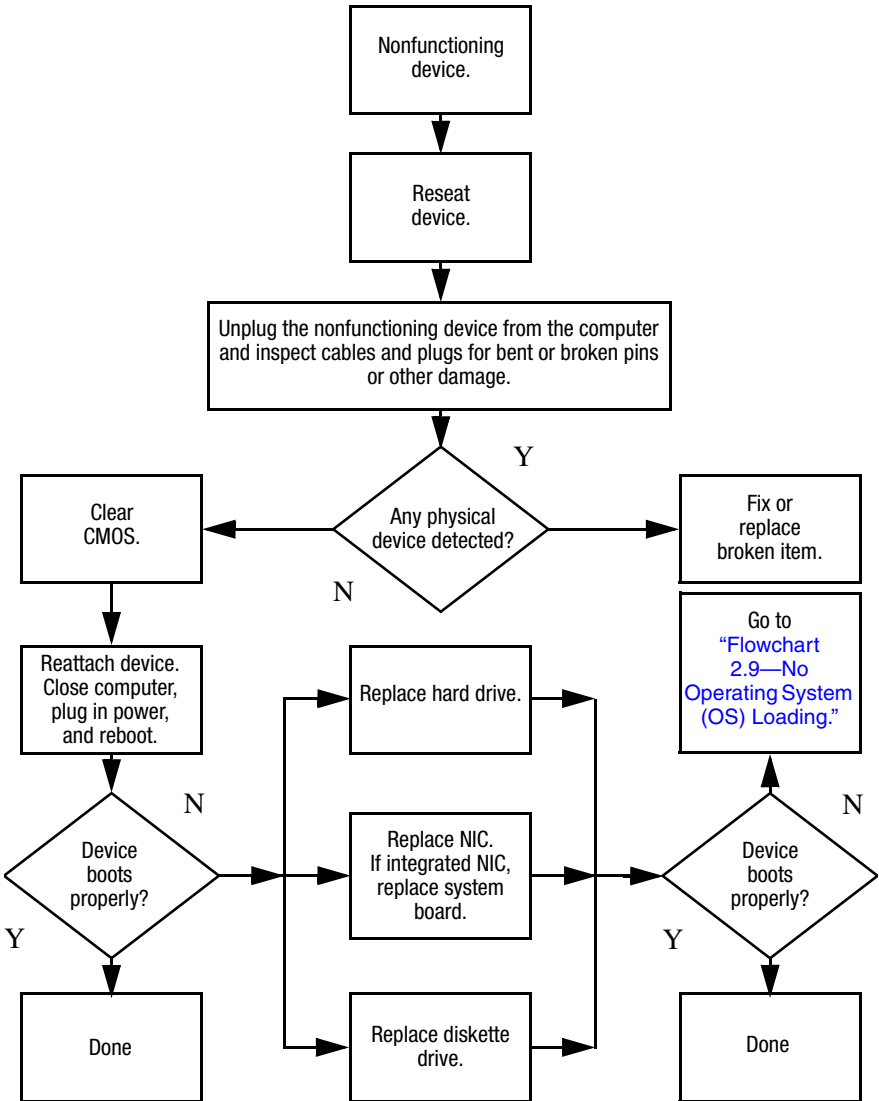

Flowchart 2.18—Nonfunctioning Keyboard

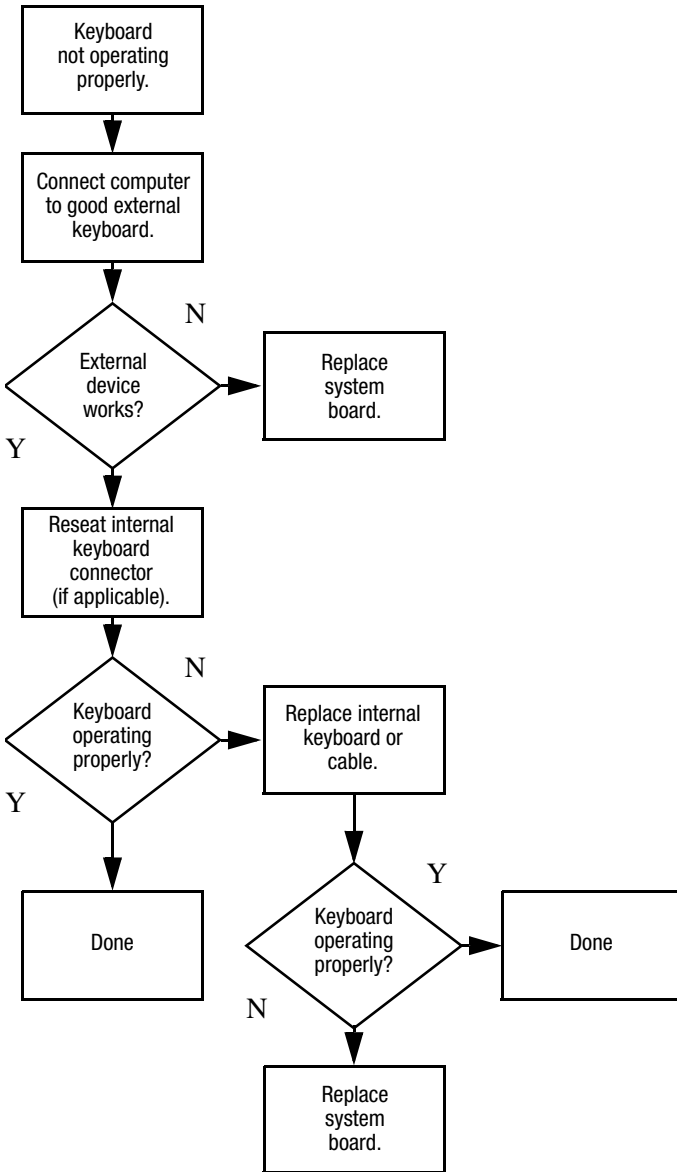

Flowchart 2.19—Nonfunctioning Pointing Device

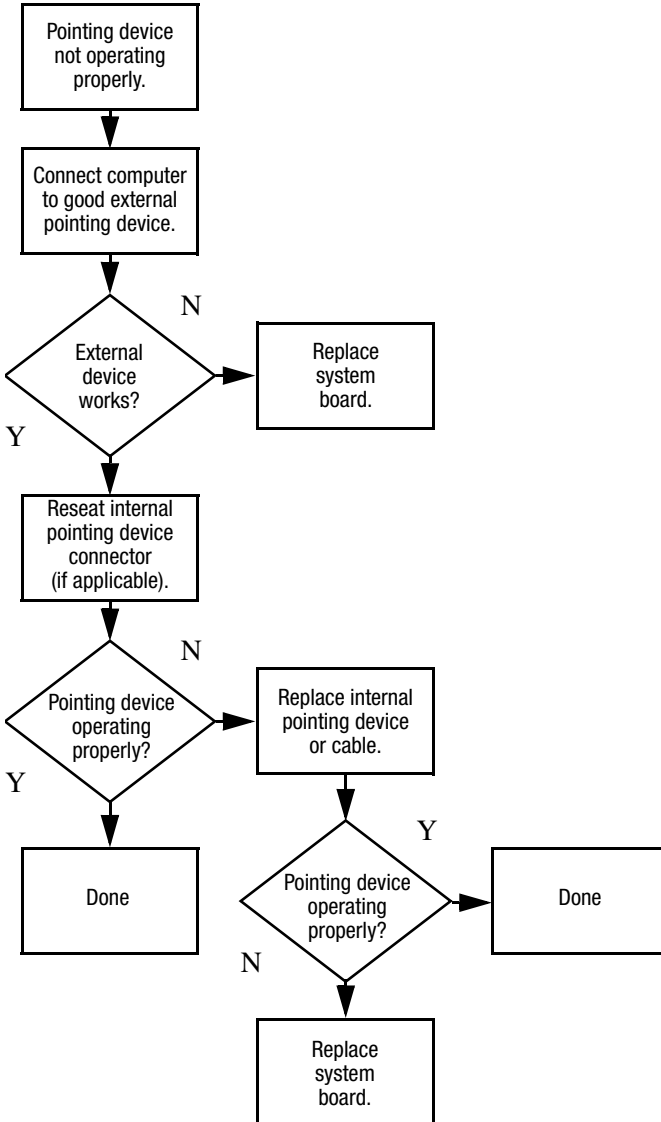

Flowchart 2.20—No Network/Modem Connection

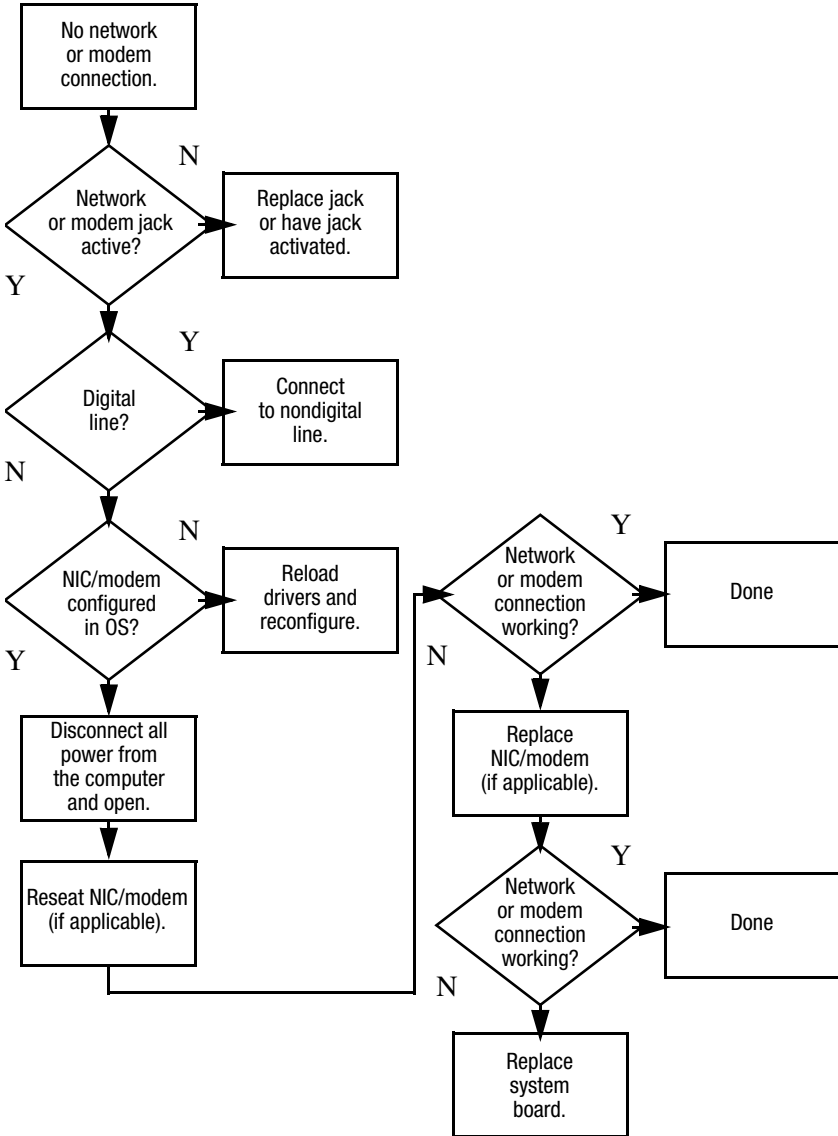

Illustrated Parts Catalog

This chapter provides an illustrated parts breakdown and a reference for spare part numbers and option part numbers.

3.1 Serial Number Location

When ordering parts or requesting information, provide the computer serial number and model number located on the bottom of the computer.



Serial Number Location

3.2 Computer Major Components

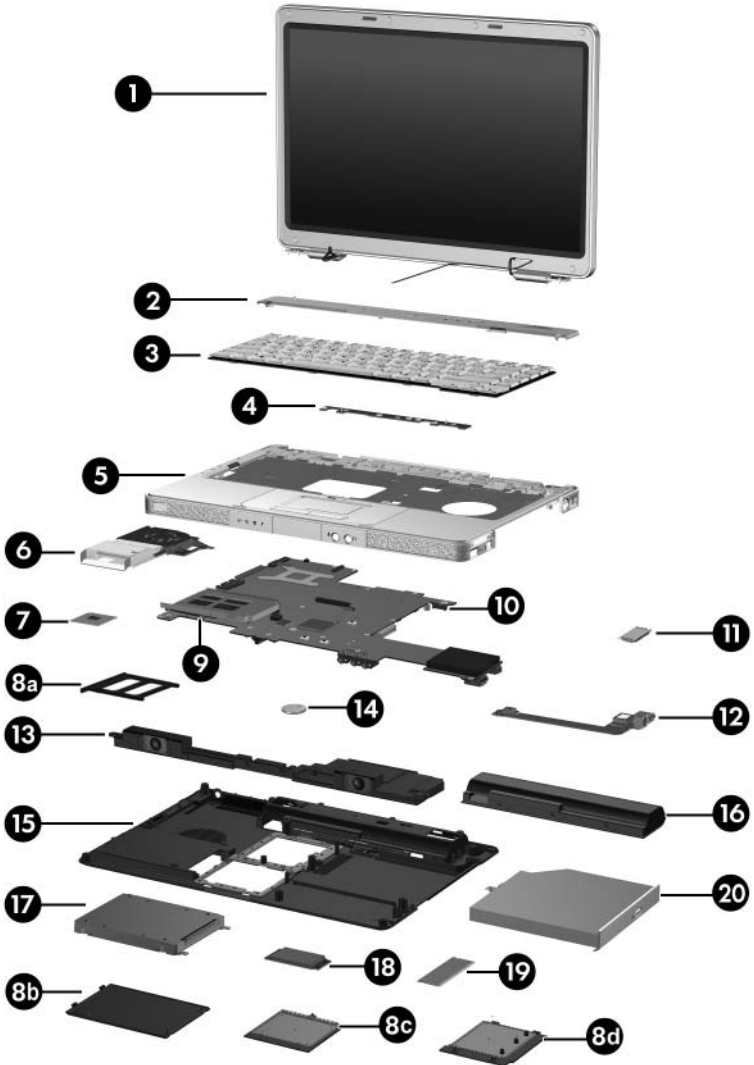

Computer Major Components

Table 3-1
Spare Parts: Computer Major Components

Item	Description	Spare Part Number		
1	Display assemblies (include wireless antenna transceivers and cables)			
	14.0-inch, WXGA, SVA with BrightView	412339-001		
	14.0-inch, WXGA	412337-001		
	 Refer to Section 3.3, "Display Assembly Components," for display assembly internal component spare part number information.			
2	Switch covers (include wireless button and light)			
	For use on models with wireless capability	394371-001		
	For use on models without wireless capability	394372-001		
3	Keyboards			
	French Canada	394277-121	Asia Pacific, Australia, Canada, Hong Kong, the People's Republic of China, and the United States	394277-001
	International	394277-B31		
	Korea	394277-AD1		
	Latin America	394277-161		
	Taiwan	394277-AB1		
	Thailand	394277-281		
4	LED board (includes cable, not illustrated)		412400-001	
5	Top covers (include TouchPad)			
	For use on full-featured computer models		412379-001	
	For use on defeatured computer models		412380-001	
6	Fan/heat sink assembly (includes thermal pad)		412397-001	

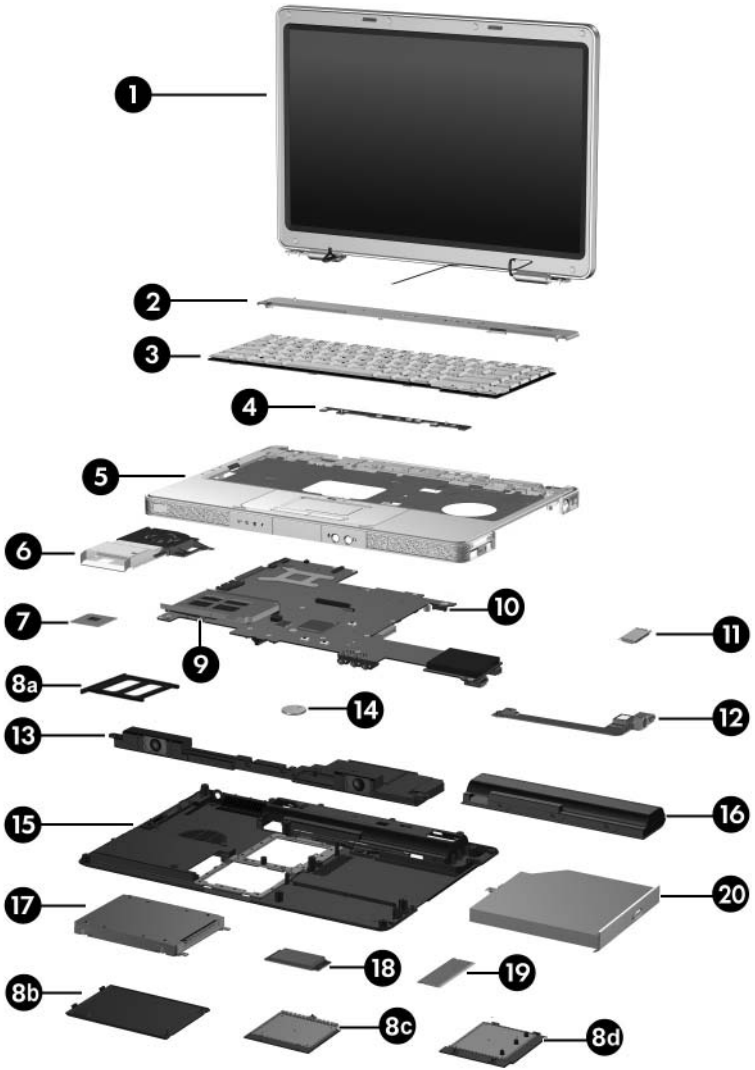

Computer Major Components

Table 3-1**Spare Parts: Computer Major Components (Continued)**

Item	Description	Spare Part Number
7	Processors (include thermal pad)	
	Intel Core Duo T2500 (2.00-GHz)	412333-001
	Intel Core Duo T2400 (1.83-GHz)	412334-001
	Intel Core Duo T2300 (1.66-GHz)	412335-001
	Intel Core Solo T1300 (1.66-GHz)	412332-001
	Plastics Kit	412385-001
	Includes:	
8a	ExpressCard slot bezel	
8b	Hard drive cover (includes two captive screws)	
8c	Mini Card compartment cover (includes 2 captive screws)	
8d	Memory module compartment cover (includes 2 captive screws)	
	Computer feet (not illustrated)	
9	ExpressCard assembly	412331-001
10	945GM System board	412240-001
11	Bluetooth® module (includes Bluetooth module cable)	412766-001
12	USB/S-Video board	412398-001
13	Speaker assembly	394373-001
14	RTC battery	412390-001
15	Base enclosure	412383-001
	Rubber Feet Kit (includes computer feet)	412579-001
16	Battery packs	
	12-cell, 8.8-AHr	396600-001
	6-cell, 4.0-AHr	396601-001

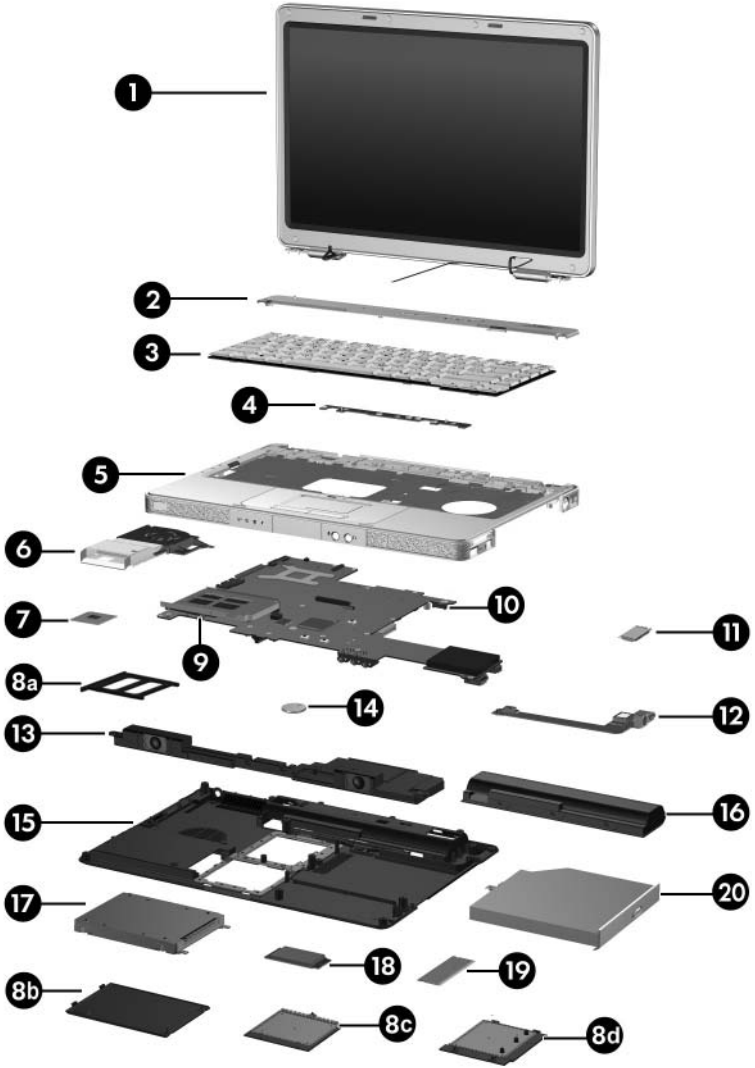

Computer Major Components

Table 3-1

Spare Parts: Computer Major Components (Continued)

Item	Description	Spare Part Number																								
17	Hard drives (include frame and connector)																									
	5400-rpm, 100-GB	412367-001																								
	5400-rpm, 80-GB	412366-001																								
	5400-rpm, 60-GB	412365-001																								
	5400-rpm, 40-GB	412364-001																								
18	Mini Card modules																									
	802.11a/b/g WLAN module for use in the countries listed below. These countries are categorized as most of the world (MOW 1).	407674-001																								
	<table border="0"> <tr> <td data-bbox="201 748 317 802">Antigua & Barbuda</td> <td data-bbox="376 748 463 802">Canada Chile</td> <td data-bbox="546 748 636 802">Panama India</td> <td data-bbox="791 748 932 802">Paraguay Saudi Arabia</td> </tr> <tr> <td data-bbox="201 807 306 834">Argentina</td> <td data-bbox="376 807 493 860">Dominican Republic</td> <td data-bbox="546 807 653 834">Indonesia</td> <td data-bbox="791 807 868 834">Taiwan</td> </tr> <tr> <td data-bbox="201 839 295 867">Australia</td> <td></td> <td data-bbox="546 839 642 867">Malaysia</td> <td data-bbox="791 839 910 867">The United States</td> </tr> <tr> <td data-bbox="201 872 302 899">Bahamas</td> <td data-bbox="376 872 440 899">Guam</td> <td data-bbox="546 872 621 899">Mexico</td> <td data-bbox="791 872 884 899">Vietnam</td> </tr> <tr> <td data-bbox="201 904 306 932">Barbados</td> <td data-bbox="376 904 493 932">Guatemala</td> <td data-bbox="546 904 689 932">New Zealand</td> <td></td> </tr> <tr> <td data-bbox="201 937 270 964">Brunei</td> <td data-bbox="376 937 497 964">Hong Kong</td> <td></td> <td></td> </tr> </table>	Antigua & Barbuda	Canada Chile	Panama India	Paraguay Saudi Arabia	Argentina	Dominican Republic	Indonesia	Taiwan	Australia		Malaysia	The United States	Bahamas	Guam	Mexico	Vietnam	Barbados	Guatemala	New Zealand		Brunei	Hong Kong			
Antigua & Barbuda	Canada Chile	Panama India	Paraguay Saudi Arabia																							
Argentina	Dominican Republic	Indonesia	Taiwan																							
Australia		Malaysia	The United States																							
Bahamas	Guam	Mexico	Vietnam																							
Barbados	Guatemala	New Zealand																								
Brunei	Hong Kong																									

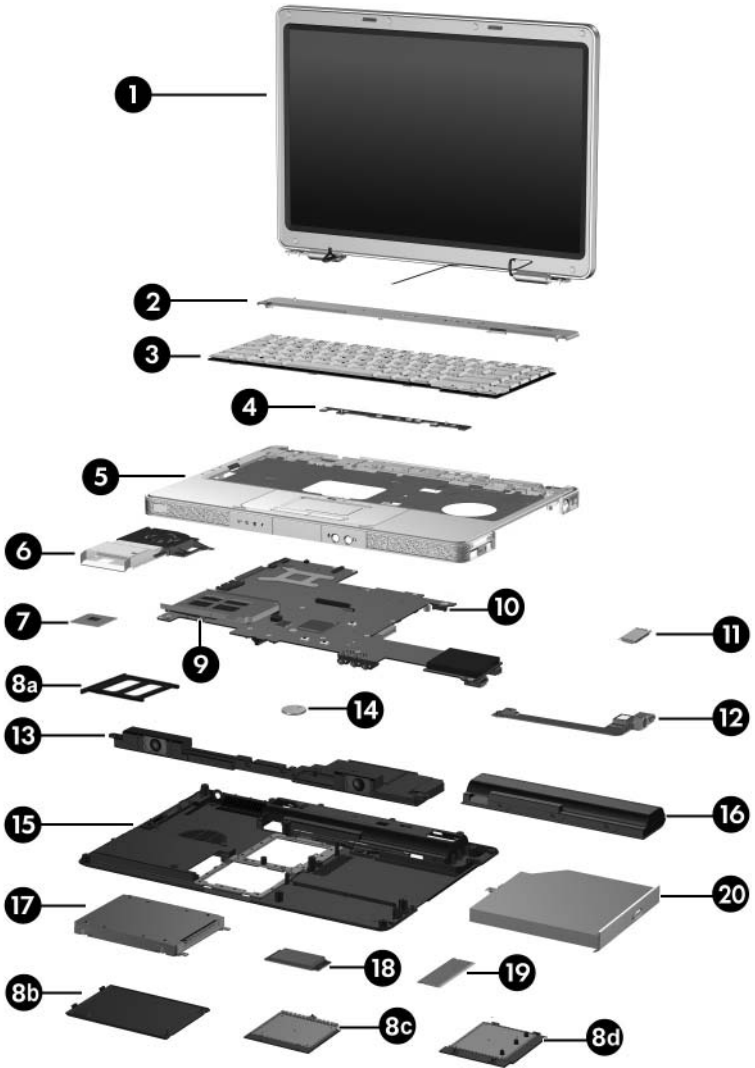

Computer Major Components

Table 3-1**Spare Parts: Computer Major Components (Continued)**

Item	Description	Spare Part Number		
18	Mini Card modules (Continued)			
	802.11a/b/g WLAN module for use in the countries listed below. These countries are categorized as most of the world (MOW 2).	407674-002		
	Aruba	Egypt	The Philippines	The Netherlands
	Austria	El Salvador	Poland	
	Azerbaijan	Estonia	Portugal	Norway
	Bahrain	Finland	Romania	Oman
	Belgium	France	Russia	Slovenia
	Bermuda	Georgia	Serbia and Montenegro	South Africa
	Bulgaria	Germany		Spain
	Cayman Islands	Greece	Singapore	Sri Lanka
	Columbia	Hungary	Slovakia	Sweden
	Croatia	Iceland	Liechtenstein	Switzerland
	Cyprus	Ireland	Lithuania	Turkey
	The Czech Republic	Italy	Luxembourg	The United Kingdom
	Denmark	Latvia	Malta	
		Lebanon	Monaco	Uzbekistan
	802.11a/b/g WLAN module for use in the countries listed below. These countries are categorized as the rest of the world (ROW).			407674-003
	China	Honduras	Qatar	Uruguay
	Ecuador	Pakistan	South Korea	Venezuela
	Haiti	Peru		
	802.11b/g WLAN module HS MOW			407159-001
	802.11b/g WLAN module HS ROW			407159-002
	802.11b/g WLAN module GL			407674-004

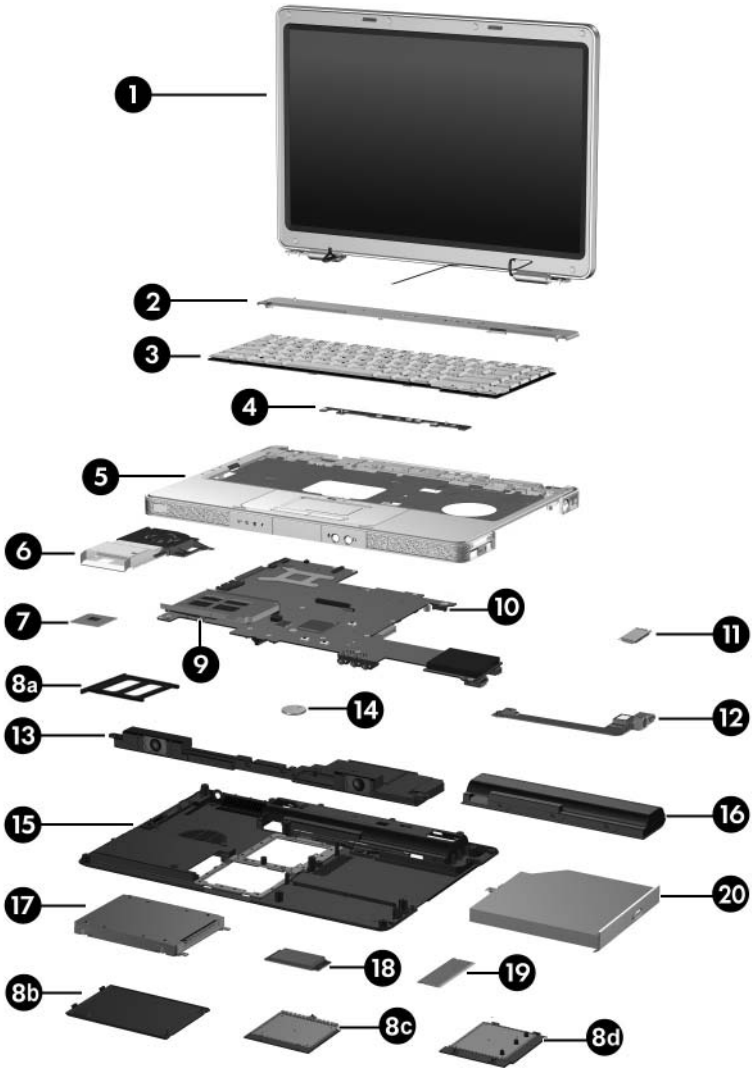

Computer Major Components

Table 3-1**Spare Parts: Computer Major Components (Continued)**

Item	Description	Spare Part Number
19	Memory modules, 1-DIMM, DDR2	
	PC2-4200, 533-MHz 1024 MB	412360-001
	512 MB	412359-001
	256 MB	412358-001
	Secure Digital (SD) Memory Card (not illustrated)	
	512-MB	407316-001
	256-MB	403573-001
20	Optical drives (include bezel)	
	24X Max DVD/CD-RW Combo Drive	412369-001
	8X Max DVD±RW/R and CD-RW Double-Layer Combo Drive	412371-001
	8X Max DVD±RW/R and CD-RW Double-Layer Combo Drive with LightScribe	394362-001
	8X Max DVD±RW/R and CD-RW Double-Layer Combo Drive with LightScribe and "HLDS"	417370-001

3.3 Display Assembly Components

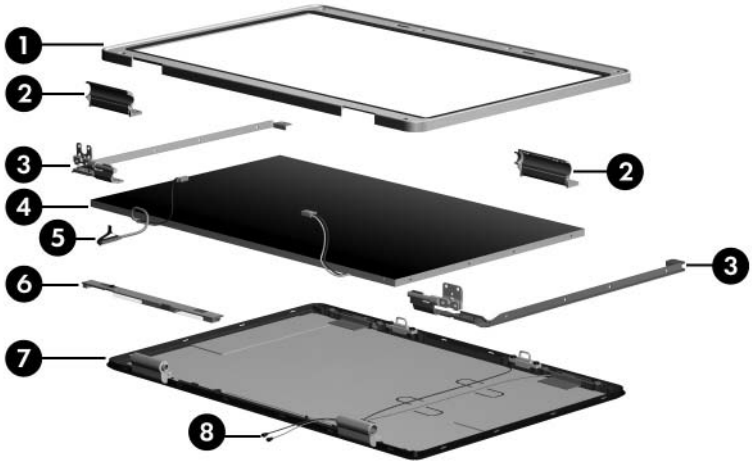

Display Assembly Components

Table 3-2
Display Assembly Components
Spare Part Number Information

Item	Description	Spare Part Number
1	Display bezel	412344-001
2	Display hinge covers	412357-001
3	Display hinges	412356-001
4	Display panels	
	14.0-inch, WXGA, SVA with BrightView	412341-001
	14.0-inch, WXGA	412340-001
5	Display cable	412354-001
6	Display inverter	412346-001
7	Display enclosure (includes wireless antenna transceivers and cables and microphone and cable)	412351-001
	Display Screw Kit (not illustrated)	417713-001
	Rubber Feet Kit (includes display bezel rubber screw covers, not illustrated)	412579-001

3.4 Mass Storage Devices

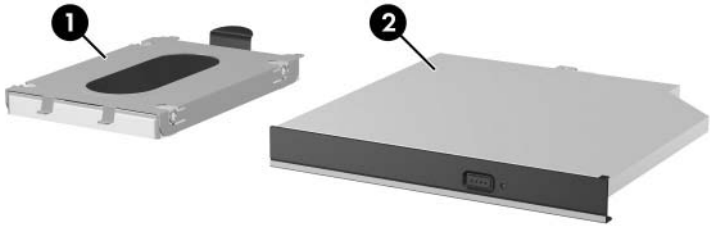

Mass Storage Devices

Table 3-3
Mass Storage Devices
Spare Part Number Information

Item	Description	Spare Part Number
1	Hard drives (include frame and connector)	
	5400-rpm	
	100-GB	412367-001
	80-GB	412366-001
	60-GB	412365-001
	40-GB	412364-001
2	Optical drives	
	24X Max DVD/CD-RW Combo Drive	412369-001
	8X Max DVD±RW/R and CD-RW Double-Layer Combo Drive	412371-001
	8X Max DVD±RW/R and CD-RW Double-Layer Combo Drive with LightScribe	394362-001
	8X Max DVD±RW/R and CD-RW Double-Layer Combo Drive with LightScribe and "HLDS"	417370-001
	USB digital drive (not illustrated)	364727-001

3.5 Plastics Kit



Plastics Kit Contents

Table 3-4
Plastics Kit
Spare Part Number Information

Item	Description	Spare Part Number
	Plastics Kit	412385-001
	Includes:	
1	ExpressCard slot bezel	
2	Hard drive cover	
3	Mini Card compartment cover	
4	Memory module compartment cover	

3.6 Miscellaneous

Table 3-5
Spare Parts: Miscellaneous (not illustrated)

Description	Spare Part Number
Logo Kit	394370-001
HP backpack	405527-001
Wired headset with volume control	371693-001
USB travel mouse	309674-001
HP xc2000 Notebook All-in-One Media Cable	404577-001
HP 65W AC Adapter	402018-001
Screw Kit (includes the following screws; refer to Appendix C, "Screw Listing," for more information on screw specifications and usage)	412387-001
<ul style="list-style-type: none"> ■ Phillips PM2.5×4.0 screw ■ Phillips PM2.5×7.0 round head screw ■ Phillips PM2.5×7.0 screw ■ Phillips PM2.5×5.0 screw 	<ul style="list-style-type: none"> ■ Phillips PM2.5×4.0 screw ■ Phillips PM2.0×3.0 screw ■ Phillips PM1.5×2.0 screw

Table 3-5

Spare Parts: Miscellaneous (not illustrated) (Continued)

Description	Spare Part Number
Power cords	
For use in:	
Australia and New Zealand	394279-011
Belgium, Europe, Finland, France, Germany, Greece, the Netherlands, Norway, Portugal, Spain, and Sweden	394279-021
Brazil	394279-201
Canada, French Canada, Latin America, Thailand, and the United States	394279-001
Denmark	394279-081
Hong Kong and the United Kingdom	394279-031
India	394279-D61
Israel	394279-BB1
Italy	394279-061
Korea	394279-AD1
People's Republic of China	394279-AA1
Switzerland	394279-111
Taiwan	394279-AB1

3.7 Sequential Part Number Listing

Table 3-6

Spare Parts: Sequential Part Number Listing

Spare Part Number	Description
309674-001	USB travel mouse
364727-001	USB digital drive (not illustrated)
371693-001	Wired headset with volume control
394277-001	Keyboard for use in the Asia Pacific, Australia, Canada, Hong Kong, the People's Republic of China, and the United States
394277-121	Keyboard for use in the French Canada
394277-161	Keyboard for use in Latin America
394277-281	Keyboard for use in Thailand
394277-AB1	Keyboard for use in Taiwan
394277-AD1	Keyboard for use in Korea
394277-B31	Keyboard for international use
394279-001	Power cord for use in Canada, French Canada, Latin America, Thailand, and the United States
394279-011	Power cord for use in Australia and New Zealand
394279-021	Power cord for use in Belgium, Europe, Finland, France, Germany, Greece, the Netherlands, Norway, Portugal, Spain, and Sweden
394279-031	Power cord for use in Hong Kong and the United Kingdom
394279-061	Power cord for use in Italy
394279-081	Power cord for use in Denmark
394279-111	Power cord for use in Switzerland
394279-201	Power cord for use in Brazil

Table 3-6

Spare Parts: Sequential Part Number Listing (*Continued*)

Spare Part Number	Description
394279-AA1	Power cord for use in the People's Republic of China
394279-AB1	Power cord for use in Taiwan
394279-AD1	Power cord for use in Korea
394279-BB1	Power cord for use in Israel
394279-D61	Power cord for use in India
394362-001	8X Max DVD±RW/R and CD-RW Double-Layer Combo Drive with LightScribe
394370-001	Logo Kit
394371-001	Switch cover for use on models with wireless capability (includes wireless button and light)
394372-001	Switch cover for use on models without wireless capability (includes wireless button and light)
394373-001	Speaker assembly
396600-001	12-cell, 8.8-AHr battery pack
396601-001	6-cell, 4.0-AHr battery pack
402018-001	HP 65W AC Adapter
403573-001	256-MB SD Memory Card
404577-001	HP xc2000 Notebook All-in-One Media Cable
405527-001	HP backpack
407159-001	802.11b/g WLAN Mini Card module HS MOW
407159-002	802.11b/g WLAN Mini Card module HS ROW
407313-001	HP Mobile Remote Control
407316-001	512-MB SD Memory Card

Table 3-6

Spare Parts: Sequential Part Number Listing (Continued)

Spare Part Number	Description		
407674-001	802.11a/b/g WLAN Mini Card module for use in the MOW 1 countries listed below.		
Antigua & Barbuda	Canada	Hong Kong	New Zealand
Argentina	Chile	Panama	Paraguay
Australia	Dominican Republic	India	Saudi Arabia
Bahamas	Guam	Indonesia	Taiwan
Barbados	Guatemala	Malaysia	The United States
Brunei		Mexico	Vietnam
407674-002	802.11a/b/g WLAN Mini Card module for use in the MOW 2 countries listed below.		
Aruba	Denmark	Lebanon	Monaco
Austria	Egypt	The Philippines	The Netherlands
Azerbaijan	El Salvador	Poland	Norway
Bahrain	Estonia	Portugal	Oman
Belgium	Finland	Romania	Slovenia
Bermuda	France	Russia	South Africa
Bulgaria	Georgia	Serbia and Montenegro	Spain
Cayman Islands	Germany	Singapore	Sri Lanka
Columbia	Greece	Slovakia	Sweden
Croatia	Hungary	Slovenia	Switzerland
Cyprus	Iceland	Liechtenstein	Turkey
The Czech Republic	Ireland	Lithuania	The United Kingdom
	Italy	Luxembourg	
	Latvia	Malta	Uzbekistan
407674-003	802.11a/b/g WLAN Mini Card module for use in the ROW countries listed below.		
China	Honduras	Qatar	Uruguay
Ecuador	Pakistan	South Korea	Venezuela
Haiti	Peru		

Table 3-6

Spare Parts: Sequential Part Number Listing (*Continued*)

Spare Part Number	Description
407674-004	802.11b/g WLAN Mini Card module GL
412240-001	945GM system board
412331-001	ExpressCard assembly
412332-001	Intel Core Solo T1300 (1.66-GHz) processor (includes thermal pad)
412333-001	Intel Core Duo T2500 (2.00-GHz) processor (includes thermal pad)
412334-001	Intel Core Duo T2400 (1.83-GHz) processor (includes thermal pad)
412335-001	Intel Core Duo T2300 (1.66-GHz) processor (includes thermal pad)
412337-001	14.0-inch, WXGA display assembly (includes wireless transceivers and cables)
412339-001	14.0-inch, WXGA, SVA with BrightView display assembly (includes wireless antenna transceivers and cables)
412340-001	14.0-inch, WXGA display panel
412341-001	14.0-inch, WXGA, SVA display panel with BrightView
412344-001	Display bezel
412346-001	Display inverter
412348-001	USB camera cable
412351-001	Display enclosure
412354-001	Display cable
412356-001	Display hinges
412357-001	Display hinge covers

Table 3-6**Spare Parts: Sequential Part Number Listing (Continued)**

Spare Part Number	Description
412358-001	1-DIMM, DDR2, PC2-4200, 533-MHz, 256-MB memory module
412359-001	1-DIMM, DDR2, PC2-4200, 533-MHz, 512-MB memory module
412360-001	1-DIMM, DDR2, PC2-4200, 533-MHz, 1024-MB memory module
412364-001	5400-rpm, 40-GB hard drive (includes frame and connector)
412365-001	5400-rpm, 60-GB hard drive (includes frame and connector)
412366-001	5400-rpm, 80-GB hard drive (includes frame and connector)
412367-001	5400-rpm, 100-GB hard drive (includes frame and connector)
412369-001	24X Max DVD/CD-RW Combo Drive
412371-001	8X Max DVD±RW/R and CD-RW Double-Layer Combo Drive
412379-001	Top cover for use with full-featured computer models (includes TouchPad)
412380-001	Top cover for use with defeatured computer models (includes TouchPad)
412383-001	Base enclosure
412385-001	Plastics Kit
412387-001	Screw Kit
412390-001	RTC battery

Table 3-6

Spare Parts: Sequential Part Number Listing (*Continued*)

Spare Part Number	Description
412397-001	Fan/heat sink assembly (includes thermal pad)
412398-001	USB/S-Video board
412400-001	LED board (includes cable)
412579-001	Rubber Feet Kit (includes computer feet used on base enclosure and display bezel rubber screw covers)
412766-001	Bluetooth module (includes Bluetooth module cable)
417370-001	8X Max DVD±RW/R and CD-RW Double-Layer Combo Drive with LightScribe and "HLDS"
417713-001	Display Screw Kit

Removal and Replacement Preliminaries

This chapter provides essential information for proper and safe removal and replacement service.

4.1 Tools Required

You will need the following tools to complete the removal and replacement procedures:

- Magnetic screwdriver
- Phillips P0 and P1 screwdrivers
- Flat-bladed screwdriver
- Tool kit—includes connector removal tool, loopback plugs, and case utility tool

4.2 Service Considerations

The following sections include some of the considerations that you should keep in mind during disassembly and assembly procedures.



As you remove each subassembly from the computer, place the subassembly (and all accompanying screws) away from the work area to prevent damage.

Plastic Parts

Using excessive force during disassembly and reassembly can damage plastic parts. Use care when handling the plastic parts. Apply pressure only at the points designated in the maintenance instructions.

Cables and Connectors



CAUTION: When servicing the computer, ensure that cables are placed in their proper locations during the reassembly process. Improper cable placement can damage the computer.

Cables must be handled with extreme care to avoid damage. Apply only the tension required to unseat or seat the cables during removal and insertion. Handle cables by the connector whenever possible. In all cases, avoid bending, twisting, or tearing cables. Ensure that cables are routed in such a way that they cannot be caught or snagged by parts being removed or replaced. Handle flex cables with extreme care; these cables tear easily.

4.3 Preventing Damage to Removable Drives

Removable drives are fragile components that must be handled with care. To prevent damage to the computer, damage to a removable drive, or loss of information, observe the following precautions:

- Before removing or inserting a hard drive, shut down the computer. If you are unsure whether the computer is off or in Hibernation, turn the computer on, and then shut it down through the operating system.
- Before removing a diskette drive or optical drive, ensure that a diskette or disc is not in the drive and ensure that the optical drive tray is closed.
- Before handling a drive, ensure that you are discharged of static electricity. While handling a drive, avoid touching the connector.
- Handle drives on surfaces covered with at least one inch of shock-proof foam.
- Avoid dropping drives from any height onto any surface.
- After removing a hard drive, CD-ROM drive, or a diskette drive, place it in a static-proof bag.
- Avoid exposing a hard drive to products that have magnetic fields, such as monitors or speakers.
- Avoid exposing a drive to temperature extremes or liquids.
- If a drive must be mailed, place the drive in a bubble pack mailer or other suitable form of protective packaging and label the package, "FRAGILE: Handle With Care."

4.4 Preventing Electrostatic Damage

Many electronic components are sensitive to electrostatic discharge (ESD). Circuitry design and structure determine the degree of sensitivity. Networks built into many integrated circuits provide some protection, but in many cases, the discharge contains enough power to alter device parameters or melt silicon junctions.

A sudden discharge of static electricity from a finger or other conductor can destroy static-sensitive devices or microcircuitry. Often the spark is neither felt nor heard, but damage occurs.

An electronic device exposed to electrostatic discharge might not be affected at all and can work perfectly throughout a normal cycle. Or the device might function normally for a while, then degrade in the internal layers, reducing its life expectancy.

4.5 Packaging and Transporting Precautions

Use the following grounding precautions when packaging and transporting equipment:

- To avoid hand contact, transport products in static-safe containers, such as tubes, bags, or boxes.
- Protect all electrostatic-sensitive parts and assemblies with conductive or approved containers or packaging.
- Keep electrostatic-sensitive parts in their containers until the parts arrive at static-free workstations.
- Place items on a grounded surface before removing items from their containers.
- Always be properly grounded when touching a sensitive component or assembly.
- Store reusable electrostatic-sensitive parts from assemblies in protective packaging or nonconductive foam.
- Use transporters and conveyors made of antistatic belts and roller bushings. Ensure that mechanized equipment used for moving materials is wired to ground and that proper materials are selected to avoid static charging. When grounding is not possible, use an ionizer to dissipate electric charges.

4.6 Workstation Precautions

Use the following grounding precautions at workstations:

- Cover the workstation with approved static-shielding material (refer to [Table 4-2, “Static-Shielding Materials”](#)).
- Use a wrist strap connected to a properly grounded work surface and use properly grounded tools and equipment.
- Use conductive field service tools, such as cutters, screwdrivers, and vacuums.
- When using fixtures that must directly contact dissipative surfaces, only use fixtures made of static-safe materials.
- Keep the work area free of nonconductive materials, such as ordinary plastic assembly aids and Styrofoam.
- Handle electrostatic-sensitive components, parts, and assemblies by the case or PCM laminate. Handle these items only at static-free workstations.
- Avoid contact with pins, leads, or circuitry.
- Turn off power and input signals before inserting or removing connectors or test equipment.

4.7 Grounding Equipment and Methods

Grounding equipment must include either a wrist strap or a foot strap at a grounded workstation.

- When seated, wear a wrist strap connected to a grounded system. Wrist straps are flexible straps with a minimum of one megohm $\pm 10\%$ resistance in the ground cords. To provide proper ground, wear a strap snugly against the skin at all times. On grounded mats with banana-plug connectors, use alligator clips to connect a wrist strap.
- When standing, use foot straps and a grounded floor mat. Foot straps (heel, toe, or boot straps) can be used at standing workstations and are compatible with most types of shoes or boots. On conductive floors or dissipative floor mats, use foot straps on both feet with a minimum of one megohm resistance between the operator and ground. To be effective, the conductive strips must be worn in contact with the skin.

Other grounding equipment recommended for use in preventing electrostatic damage includes:

- Antistatic tape
- Antistatic smocks, aprons, and sleeve protectors
- Conductive bins and other assembly or soldering aids
- Nonconductive foam
- Conductive tabletop workstations with ground cords of one megohm resistance
- Static-dissipative tables or floor mats with hard ties to the ground
- Field service kits
- Static awareness labels
- Material-handling packages
- Nonconductive plastic bags, tubes, or boxes
- Metal tote boxes
- Electrostatic voltage levels and protective materials

Table 4-1 shows how humidity affects the electrostatic voltage levels generated by different activities.

Table 4-1
Typical Electrostatic Voltage Levels

Event	Relative Humidity		
	10%	40%	55%
Walking across carpet	35,000 V	15,000 V	7,500 V
Walking across vinyl floor	12,000 V	5,000 V	3,000 V
Motions of bench worker	6,000 V	800 V	400 V
Removing DIPS from plastic tube	2,000 V	700 V	400 V
Removing DIPS from vinyl tray	11,500 V	4,000 V	2,000 V
Removing DIPS from Styrofoam	14,500 V	5,000 V	3,500 V
Removing bubble pack from PCB	26,500 V	20,000 V	7,000 V
Packing PCBs in foam-lined box	21,000 V	11,000 V	5,000 V



A product can be degraded by as little as 700 V.

Table 4-2 lists the shielding protection provided by antistatic bags and floor mats.

Table 4-2
Static-Shielding Materials

Material	Use	Voltage Protection Level
Antistatic plastic	Bags	1,500 V
Carbon-loaded plastic	Floor mats	7,500 V
Metallized laminate	Floor mats	5,000 V

5

Removal and Replacement Procedures

This chapter provides removal and replacement procedures.

There are as many as 84 screws, in 8 different sizes, that must be removed, replaced, or loosened, when servicing the computer. Make special note of each screw size and location during removal and replacement.

Refer to [Appendix C, “Screw Listing,”](#) for detailed information on screw sizes, locations, and usage.

5.1 Serial Number

Report the computer serial number to HP when requesting information or ordering spare parts. The serial number is located on the bottom of the computer.



Serial Number Location

5.2 Disassembly Sequence Chart

Use the chart below to determine the section number to be referenced when removing computer components.

Disassembly Sequence Chart

Section	Description	# of Screws Removed
5.3	Preparing the Computer for Disassembly	
	Battery pack	0
5.4	Hard Drive	2 loosened to remove the hard drive cover 4 removed to disassemble the hard drive
5.5	Computer Feet	0
5.6	Memory Module	2 loosened to remove the memory module compartment cover
5.7	Mini Card Module	1 loosened to remove the Mini Card module compartment cover 2 removed to remove the Mini Card module
	 To prevent an unresponsive system and the display of a warning message, install only a Mini Card device authorized for use in your computer by the governmental agency that regulates wireless devices in your country. If you install a device and then receive a warning message, remove the device to restore computer functionality. Then contact Customer Care.	
5.8	Optical Drive	1 to remove the optical drive 2 to remove the optical drive bracket
5.9	Switch Cover	2
5.10	Keyboard	4

Disassembly Sequence Chart (*Continued*)

Section	Description	# of Screws Removed
5.11	Display Assembly	4
	Display bezel	6
	Display release hooks	4
	Display inverter	1
	Display hinge covers	4
	Display panel	2
	Display hinges	4
	Wireless antenna transceivers	4
5.12	Base Enclosure	18
5.13	USB/S-Video Board	2
5.14	Bluetooth Module	2
5.15	Speaker Assembly	0
5.16	RTC Battery	0
5.17	Fan/Heat Sink Assembly	4 loosened
5.18	Processor	1 loosened
5.19	System Board	3
5.20	LED Board	2
5.21	ExpressCard Assembly	2

5.3 Preparing the Computer for Disassembly

Before you begin any removal or installation procedures:

1. Shut down the computer. If you are unsure whether the computer is off or in Hibernation, turn the computer on, and then shut it down through the operating system.
2. Disconnect all external devices connected to the computer.
3. Disconnect the power cord.

Battery Pack Spare Part Number Information

12-cell, 8.8-AHr	396600-001
6-cell, 4.0-AHr	396601-001

4. Remove the battery pack by following these steps:
 - a. Turn the computer upside down with the front panel toward you.
 - b. Slide and hold the battery release latch **1** to the left. (The front edge of the battery pack disengages from the computer.)
 - c. Lift the front edge of the battery pack **2** up and swing it back.
 - d. Remove the battery pack.

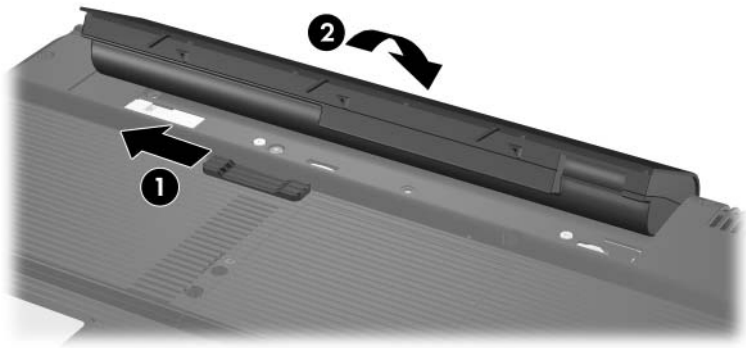

Removing the Battery Pack

Reverse the above procedure to install the battery pack.

5.4 Hard Drive

Hard Drive Spare Part Number Information

Frame and connector included.

5400-rpm, 100-GB	412367-001
5400-rpm, 80-GB	412366-001
5400-rpm, 60-GB	412365-001
5400-rpm, 40-GB	412364-001

1. Prepare the computer for disassembly (refer to [Section 5.3](#)).

2. Loosen the two black Phillips PM2.0x5.0 screws ❶ that secure the hard drive cover to the computer.
3. Lift the left side of the cover ❷ and swing it to the right.
4. Remove the hard drive cover.



The hard drive cover is included in the Plastics Kit, spare part number 412385-001.

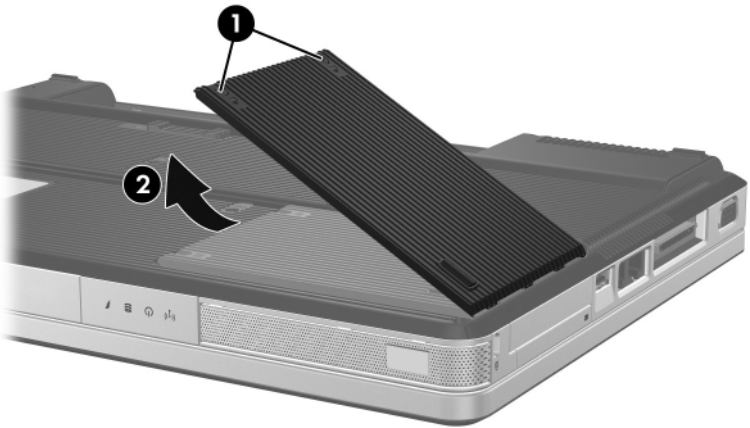

Removing the Hard Drive Cover

5. Use the mylar tab ❶ to lift the hard drive ❷ until it disconnects from the computer.
6. Remove the hard drive from the hard drive bay.

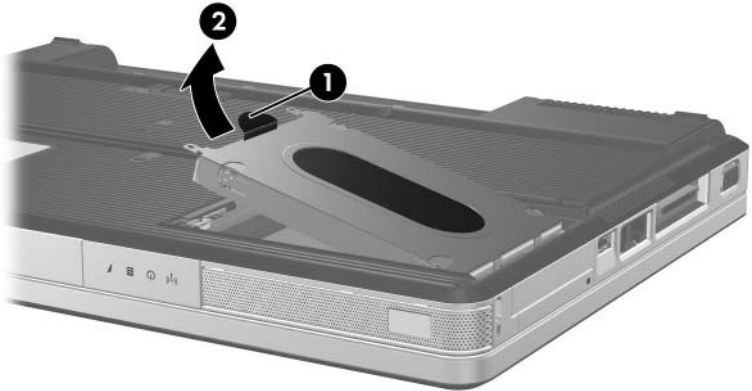

Removing the Hard Drive

7. Remove the four Phillips PM2.5×4.0 screws ❶ that secure the hard drive frame to the hard drive.
8. Lift the frame ❷ straight up to remove it from the hard drive.
9. Slide the hard drive connector ❸ off the hard drive.

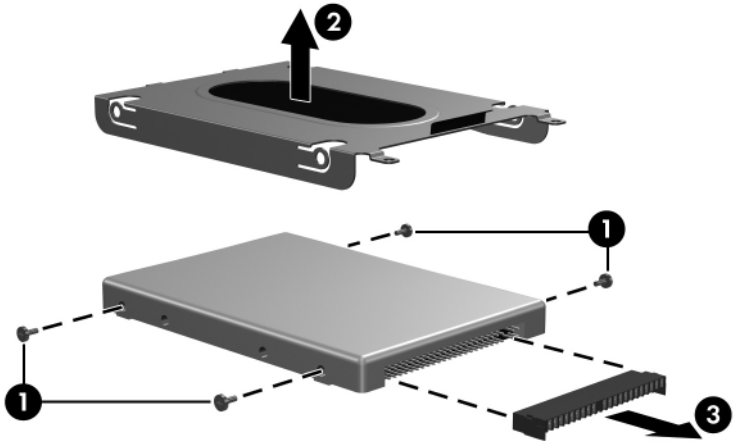

Removing the Hard Drive Frame and Connector

Reverse the above procedure to install and reassemble the hard drive.

5.5 Computer Feet

The computer feet are adhesive-backed rubber pads. The feet are included in the Rubber Feet Kit, spare part number 412579-001.

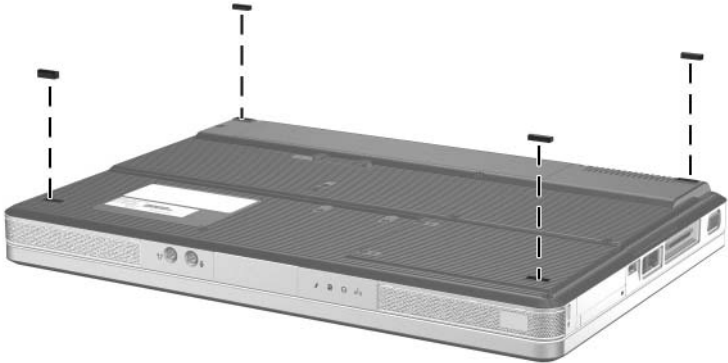

Replacing the Computer Feet

5.6 Memory Module

Memory Module Spare Part Number Information

PC2-4200, 533-MHz

1024 MB 412360-001

512 MB 412359-001

256 MB 412358-001

1. Prepare the computer for disassembly (refer to [Section 5.3](#)).
2. Loosen the two black Phillips PM2.0×5.0 screws ❶ that secure the memory module compartment cover to the computer.
3. Lift the front edge of the memory module compartment cover ❷ up and swing it back.
4. Remove the memory module compartment cover.



The memory module compartment cover is included in the Plastics Kit, spare part number 412385-001.

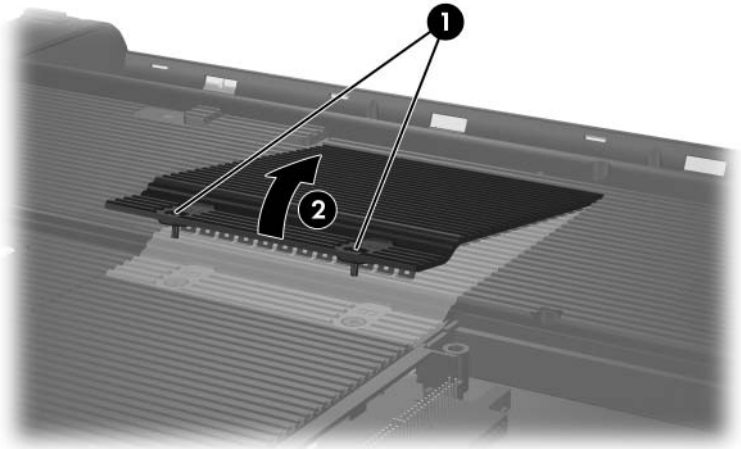

Removing the Memory Module Compartment Cover

5. Spread the retaining tabs **1** on each side of the memory module socket to release the memory module. (The edge of the memory module opposite the memory module socket rises away from the computer.)
6. Slide the module **2** away from the socket at an angle.



Memory modules are designed with a notch **3** to prevent incorrect installation into the memory module socket.

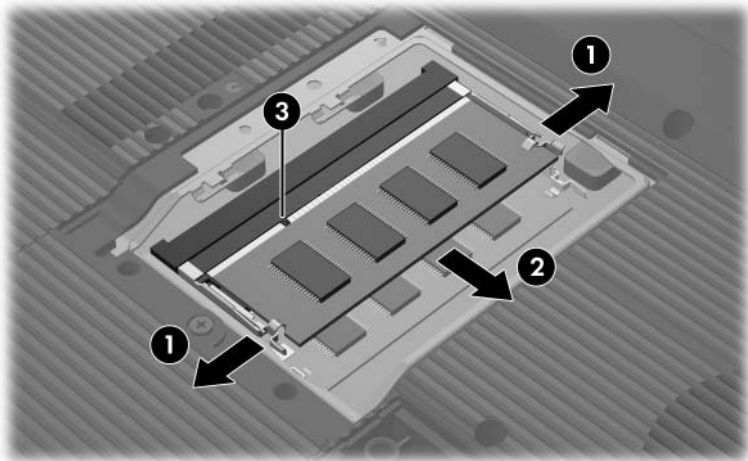

Removing the Memory Module

Reverse the above procedure to install a memory module.

5.7 Mini Card Module

Mini Card Module

Spare Part Number Information

802.11a/b/g WLAN module for use in the MOW 1 countries listed below.			407674-001
Antigua & Barbuda	Chile	Panama	Paraguay
Argentina	Dominican Republic	India	Saudi Arabia
Australia		Indonesia	Taiwan
Bahamas	Guam	Malaysia	The United States
Barbados	Guatemala	Mexico	Vietnam
Brunei	Hong Kong	New Zealand	
Canada			
802.11a/b/g WLAN module for use in the MOW 2 countries listed below.			407674-002
Aruba	El Salvador	Poland	Norway
Austria	Estonia	Portugal	Oman
Azerbaijan	Finland	Romania	Slovenia
Bahrain	France	Russia	South Africa
Belgium	Georgia	Serbia and Montenegro	Spain
Bermuda	Germany	Singapore	Sri Lanka
Bulgaria	Greece	Slovakia	Sweden
Cayman Islands	Hungary	Liechtenstein	Switzerland
Columbia	Iceland	Lithuania	Turkey
Croatia	Ireland	Luxembourg	The United Kingdom
Cyprus	Italy	Malta	Uzbekistan
The Czech Republic	Latvia	Monaco	
Denmark	Lebanon	The Netherlands	
Egypt	The Phillipines		

Mini Card Module

Spare Part Number Information (*Continued*)

802.11a/b/g WLAN module for use in the ROW countries listed below. 407674-003

China	Honduras	Qatar	Uruguay
Ecuador	Pakistan	South Korea	Venezuela
Haiti	Peru		

802.11b/g WLAN module HS MOW 407159-001

802.11b/g WLAN module HS ROW 407159-002

802.11b/g WLAN module GL 407674-004

1. Prepare the computer for disassembly ([Section 5.3](#)).

2. Loosen the black Phillips PM2.0×5.0 screw ❶ that secures the Mini Card compartment cover to the computer.
3. Lift the rear edge of the Mini Card compartment cover ❷ up, and then swing it forward.
4. Remove the Mini Card compartment cover.



The Mini Card compartment cover is included in the Plastics Kit, spare part number 412385-001.



Removing the Mini Card Compartment Cover

5. Make note of which wireless antenna cable is attached to which antenna clip on the Mini Card module before disconnecting the cables, then disconnect the cables ❶ from the module.
6. Remove the two black Phillips PM2.0×5.0 screws ❷ that secure the Mini Card module to the system board. (The edge of the module opposite the Mini Card socket rises away from the computer).
7. Remove the Mini Card module ❸ by pulling the module away from the socket at an angle.



Mini Card modules are designed with a notch ❹ to prevent incorrect installation into the Mini Card module socket.

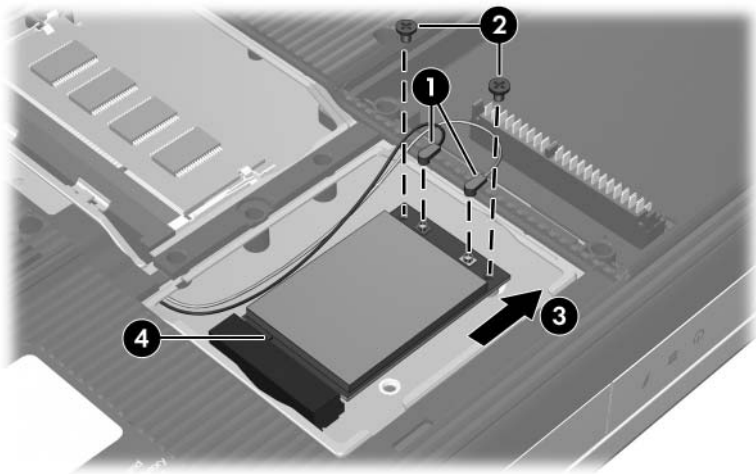

Removing a Mini Card Module

Reverse the above procedure to install a Mini Card module.

5.8 Optical Drive

Optical Drive Spare Part Number Information

24X Max DVD/CD-RW Combo Drive	412369-001
8X Max DVD±RW/R and CD-RW Double-Layer Combo Drive	412371-001
8X Max DVD±RW/R and CD-RW Double-Layer Combo Drive with LightScribe	394362-001
8X Max DVD±RW/R and CD-RW Double-Layer Combo Drive with LightScribe and "HLDS"	417370-001

1. Prepare the computer for disassembly ([Section 5.3](#)).

2. Remove the Phillips PM2.0×8.5 screw **1** that secures the optical drive to the computer.
3. Insert a thin tool, such as a paper clip, into the media tray release hole **2**. (The optical drive media tray releases from the optical drive.)
4. Use the media tray frame to slide the optical drive **3** to the left.
5. Remove the optical drive.

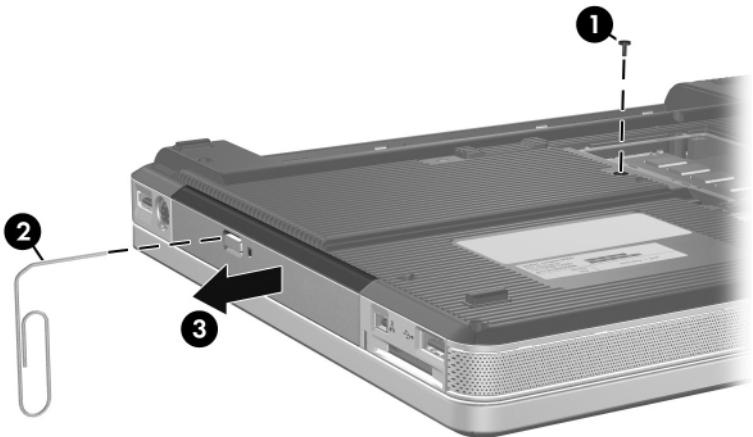

Removing the Optical Drive

6. Remove the two Phillips PM2.0×2.0 screws **1** that secure the optical drive bracket to the optical drive.
7. Remove the optical drive bracket **2**.

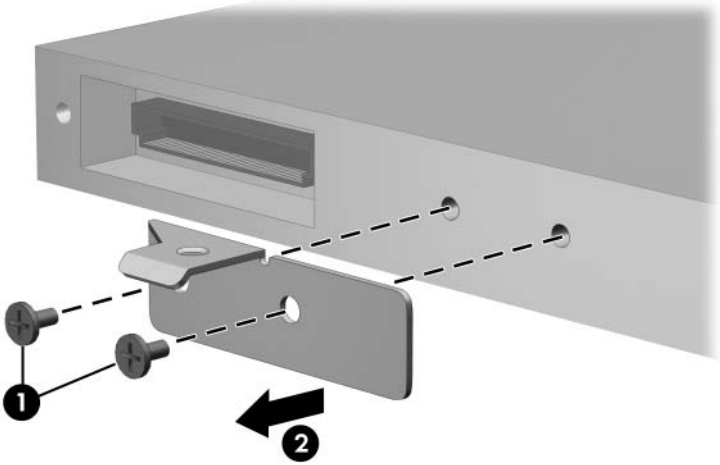

Removing the Optical Drive Bracket

Reverse the above procedure to reassemble and install the optical drive.

5.9 Switch Cover

Switch Cover Spare Part Number Information

For use on models with wireless capability	394371-001
For use on models without wireless capability	394372-001

1. Prepare the computer for disassembly ([Section 5.3](#)).

2. Position the computer with the rear panel toward you.
3. Remove the two silver Phillips PM2.0×5.0 screws that secure the switch cover to the computer.

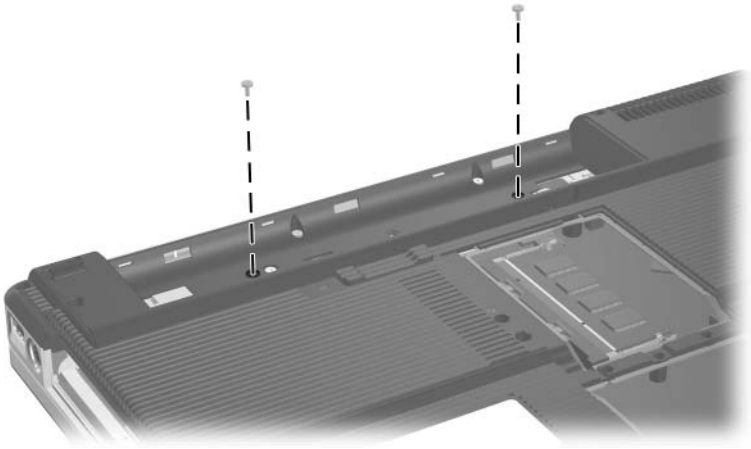

Removing the Switch Cover Screws

4. Turn the computer display side up with the front panel toward you.
5. Open the computer as far as possible.
6. Insert a flat-bladed screwdriver into the slots located behind the **f1**, **f5**, **f11**, and **insert** keys ❶ and lift up on the front edge of the switch cover ❷ until it disengages from the computer.
7. Remove the switch cover.

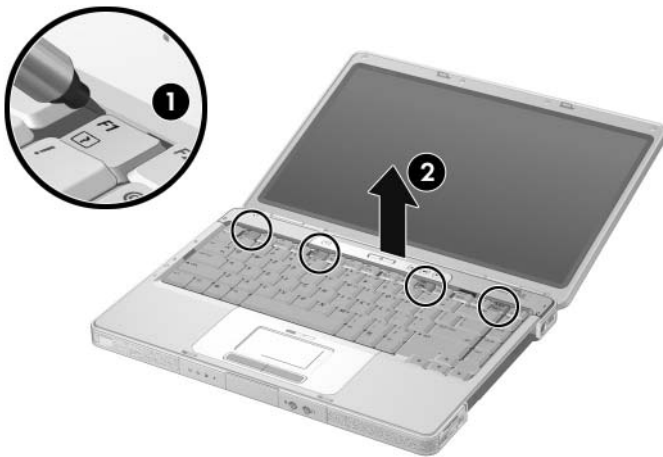

Removing the Switch Cover

Reverse the above procedure to install the switch cover.

5.10 Keyboard

Keyboard Spare Part Number Information

French Canada	394277-121	Asia Pacific, Australia,	394277-001
International	394277-B31	Canada,	
Korea	394277-AD1	Hong Kong,	
Latin America	394277-161	the People's Republic	
Taiwan	394277-AB1	of China, and the	
Thailand	394277-281	United States	

1. Prepare the computer for disassembly ([Section 5.3](#)).
2. Remove the optical drive ([Section 5.8](#)).
3. Remove the switch cover ([Section 5.9](#)).
4. Close the computer.
5. Turn the computer upside down with the front toward you.

6. Remove the four Phillips PM2.0×3.0 screws ❶ that secure the keyboard to the computer.
7. Swing the rear edge of the keyboard ❷ up and forward until it rests on the palm rest.

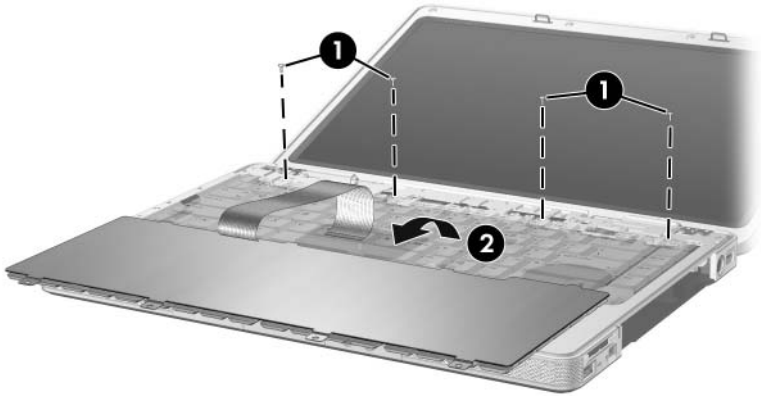

Releasing the Keyboard

8. Release the ZIF connector **1** to which the keyboard cable is connected and disconnect the keyboard cable **2** from the system board.



Disconnecting the Keyboard Cable

9. Remove the keyboard.
- Reverse the above procedure to install the keyboard.

5.11 Display Assembly

Display Assembly Spare Part Number Information

14.0-inch, WXGA, SVA with Brightview	412339-001
14.0-inch, WXGA	412337-001

1. Prepare the computer for disassembly ([Section 5.3](#)).
2. Remove the memory module compartment cover ([Section 5.6](#)).
3. Remove the Mini Card compartment cover and disconnect the wireless antenna cables from the Mini Card ([Section 5.7](#)).
4. Remove the wireless antenna cables from the Mini Card and memory module compartments.
5. Remove the switch cover ([Section 5.9](#)).
6. Remove the keyboard ([Section 5.10](#)).
7. Turn the computer display side up with the front panel toward you.
8. Open the display as far as possible.

9. Disconnect the display cable ❶ from the system board.
10. Remove the tape ❷ that secures the wireless antenna cables to the top cover.
11. Remove the cables from the clips ❸ in the top cover.

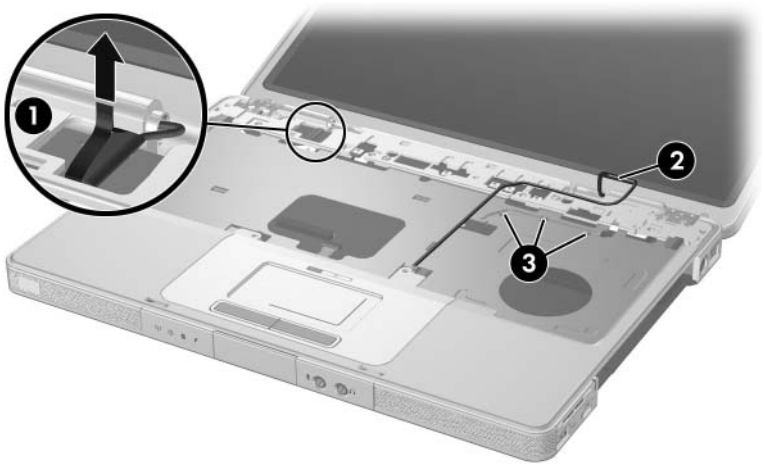

Disconnecting the Display Cable and Removing the Wireless Antenna Cables



CAUTION: Support the display assembly when removing the following screws. Failure to support the display assembly can result in damage to the display assembly and other computer components.

12. Remove the four black Phillips PM2.0x5.0 screws ❶ that secure the display assembly to the computer.
13. Remove the display assembly ❷.

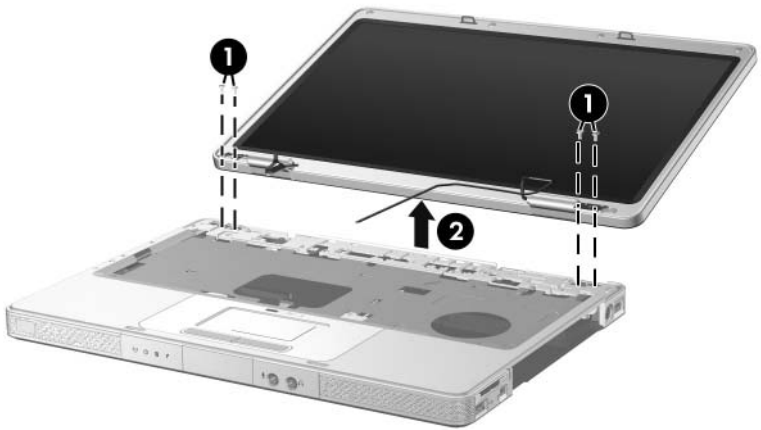

Removing the Display Assembly

14. Remove the six rubber screw covers ❶ and the six Phillips PM2.5×6.0 screws ❷ that secure the display bezel to the display assembly.



The rubber screw covers are included in the Rubber Feet Kit, spare part number 412579-001.

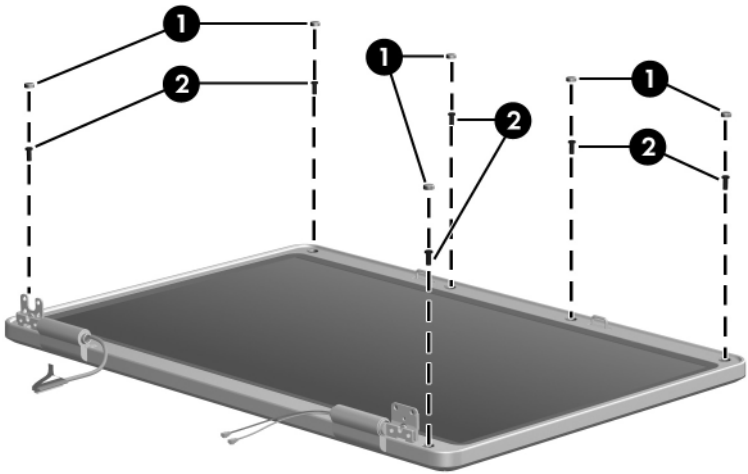

Removing the Display Bezel Screws

Display Assembly Components

Spare Part Number Information

Description	Spare Part Number
Display bezel	412344-001
Display enclosure (includes wireless antenna transceivers and cables and microphone and cable)	412351-001

- Flex the insides edges of the left and right sides **1** and the top and bottom sides **2** of the display bezel until the bezel disengages from the display enclosure.
- Remove the display bezel **3**.

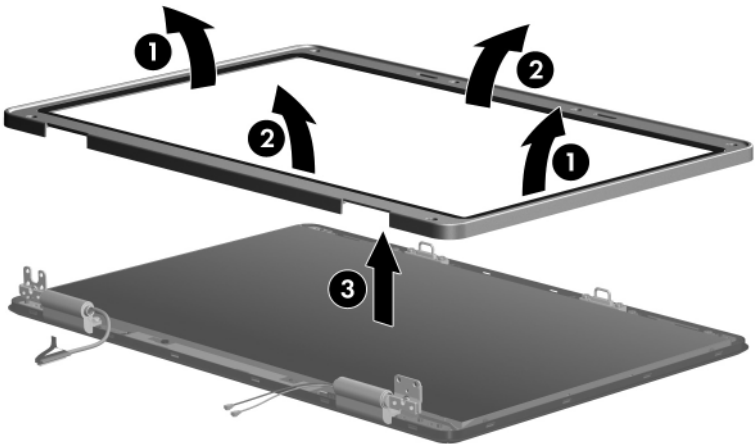

Removing the Display Bezel



The display release hooks are available in the Display Hinge Kit, spare part number 412356-001.

17. If it is necessary to replace the display release hooks, remove the two Phillips PM2.5×6.0 screws ❶ that secure each hook to the display enclosure.
18. Remove the display release hooks ❷.

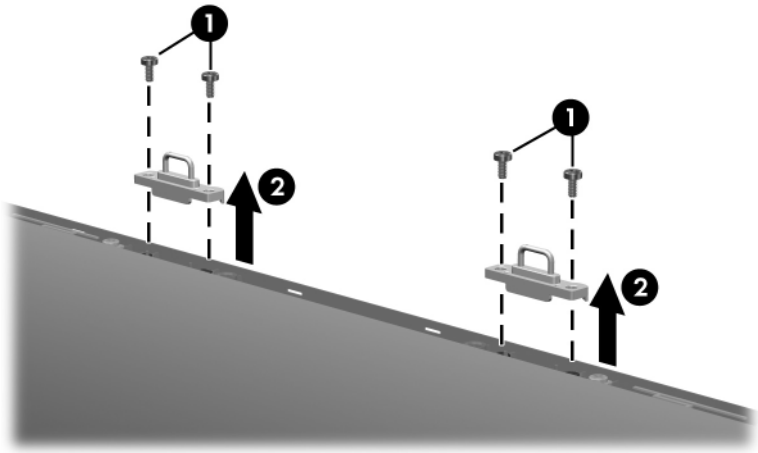

Removing the Display Release Hooks

Display Assembly Components

Spare Part Number Information

Description	Spare Part Number
Display inverter	412346-001

19. Remove the Phillips PM2.0x3.0 screw **1** that secures the display inverter to the display enclosure.
20. Lift the inverter **2** out of the enclosure as far as the display cable and backlight cables will allow.
21. Disconnect the display **3** and backlight cables **4** from the inverter.
22. Remove the display inverter.

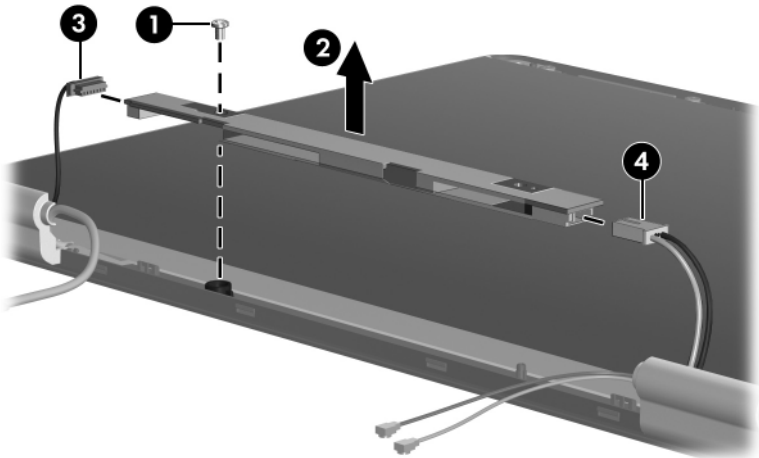

Removing the Display Inverter

Display Assembly Components

Spare Part Number Information

Description	Spare Part Number
Display hinge covers	412357-001

23. If it is necessary to replace the display hinge covers, remove the two Phillips PM2.5×6.0 screws **1** that secure each cover to the display enclosure.
24. Remove the display hinge covers **2**.

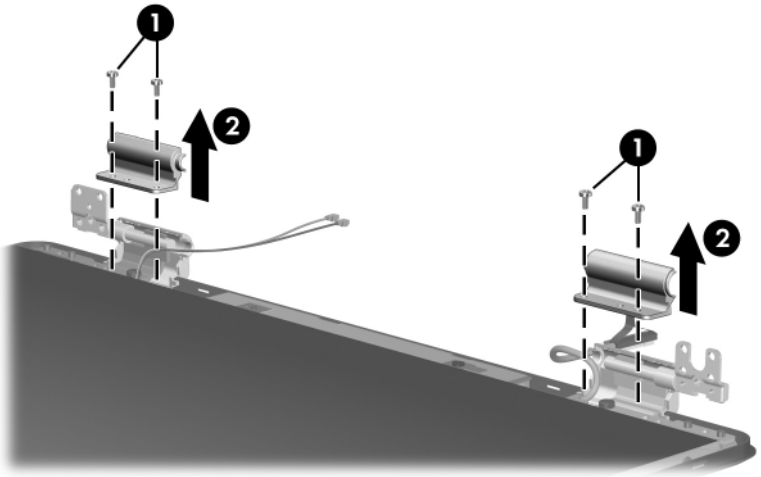

Removing the Display Hinge Covers

Display Assembly Components

Spare Part Number Information

Description	Spare Part Number
Display panels	
14.0-inch, WXGA, SVA with BrightView	412341-001
14.0-inch, WXGA	412340-001

25. Remove the two Phillips PM2.5×6.0 screws ❶ that secure the display panel to the display enclosure.
26. Remove the display panel ❷ from the display enclosure.

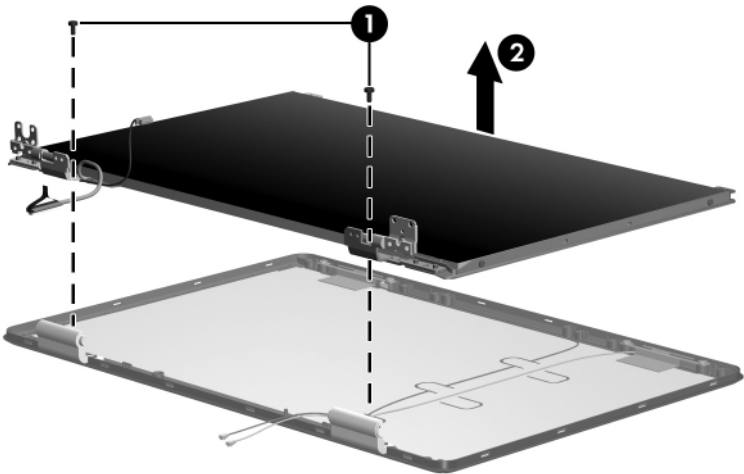

Removing the Display Panel

Display Assembly Components

Spare Part Number Information

Description	Spare Part Number
Display Hinge Kit, includes: Display hinges Display release hooks	412356-001

27. If it is necessary to replace the display hinges, remove the two Phillips PM2.0×3.0 screws ❶ that secure each hinge to the display panel.
28. Remove the display hinges ❷.

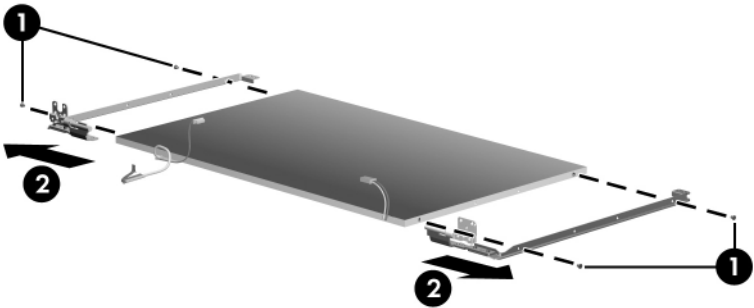

Removing the Display Hinges



The wireless antenna transceivers and cables are included with the display enclosure, spare part number 412351-001.

29. If it is necessary to replace the wireless transceivers and cables, remove the two Phillips PM2.0×3.0 screws **1** that secure the left and right transceivers to the display enclosure.
30. Release the retention tabs **2** built in to the display enclosure lining that secure the wireless antenna cables to the display enclosure.
31. Detach the wireless antenna transceivers **3** from the display enclosure.
32. Remove the wireless antenna transceivers and cables **4**.

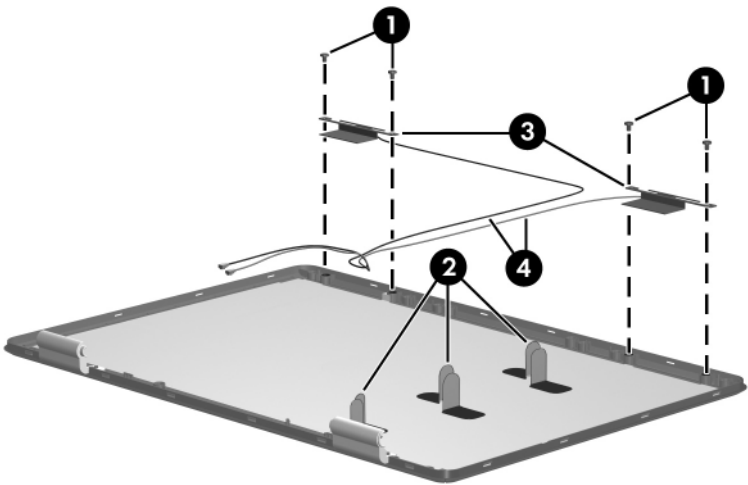

Removing the Wireless Antenna Transceivers and Cables

Reverse the above procedure to reassemble and install the display assembly

5.12 Base Enclosure

Base Enclosure Spare Part Number Information

Base enclosure	412383-001
----------------	------------

1. Prepare the computer for disassembly ([Section 5.3](#)) and remove the following components:
 - ❑ Hard drive ([Section 5.4](#))
 - ❑ Optical drive ([Section 5.8](#))
 - ❑ Switch cover ([Section 5.9](#))
 - ❑ Keyboard ([Section 5.10](#))
 - ❑ Display assembly ([Section 5.11](#))

2. Remove the fifteen Phillips PM2.0×8.5 screws that secure the base enclosure to the computer.

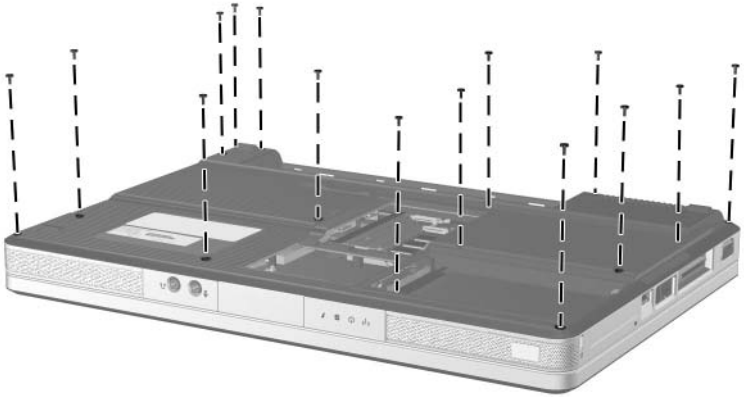

Removing the Base Enclosure Screws

3. Remove the three silver Phillips PM2.0×5.0 screws that secure the base enclosure to the computer.
4. Lift the base enclosure straight up and remove it.

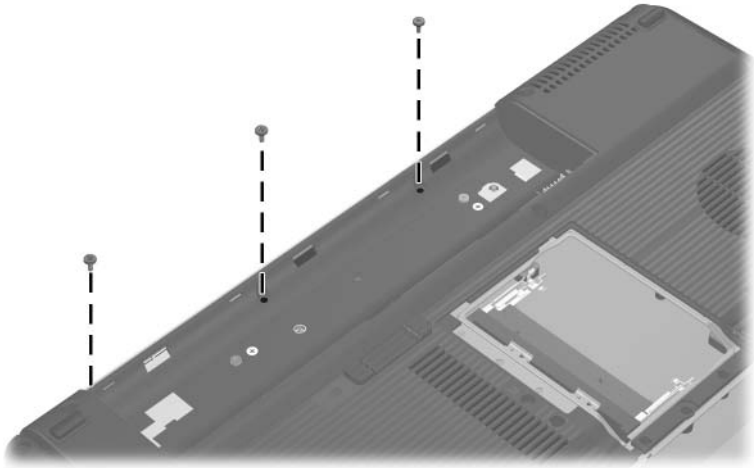

Removing the Base Enclosure

Reverse the above procedure to install the base enclosure.

5.13 USB/S-Video Board

USB/S-Video Board

Spare Part Number Information

USB/S-Video Board

412398-001

1. Prepare the computer for disassembly ([Section 5.3](#)) and remove the following components:
 - ❑ Optical drive ([Section 5.8](#))
 - ❑ Switch cover ([Section 5.9](#))
 - ❑ Keyboard ([Section 5.10](#))
 - ❑ Display assembly ([Section 5.11](#))
 - ❑ Base enclosure ([Section 5.12](#))

2. Remove the two silver Phillips PM2.0×5.0 screws ❶ that secure the USB/S-Video board to the top cover.
3. Lift up on the right side of the board ❷ to disconnect it from the system board.
4. Remove the USB/S-Video board.

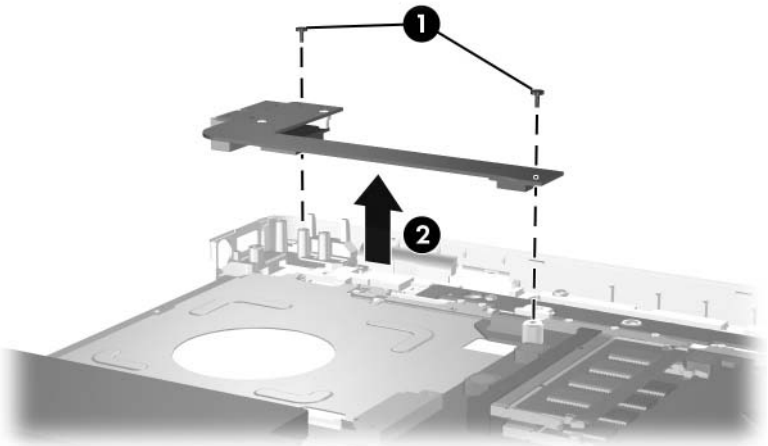

Removing the USB/S-Video Board

Reverse the above procedure to install the USB/S-Video board.

5.14 Bluetooth Module

Bluetooth Module Spare Part Number Information

Bluetooth module

412766-001

1. Prepare the computer for disassembly ([Section 5.3](#)) and remove the following components:
 - ❑ Optical drive ([Section 5.8](#))
 - ❑ Switch cover ([Section 5.9](#))
 - ❑ Keyboard ([Section 5.10](#))
 - ❑ Display assembly ([Section 5.11](#))
 - ❑ Base enclosure ([Section 5.12](#))
 - ❑ USB/S-Video board ([Section 5.13](#))

2. Turn the USB/S-Video board upside down with the USB port facing you.
3. Remove the two PM1.5×3.5 screws ❶ that secure the Bluetooth module to the USB/S-Video board.
4. Disconnect the Bluetooth module cable ❷ from the USB/S-Video board.
5. Remove the Bluetooth module ❸.

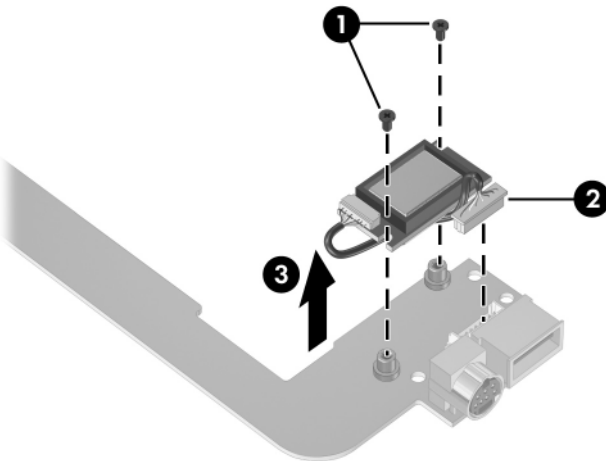

Removing the Bluetooth Module

Reverse the above procedure to install the Bluetooth module.

5.15 Speaker Assembly

Speaker Assembly Spare Part Number Information

Speaker assembly

394373-001

1. Prepare the computer for disassembly ([Section 5.3](#)) and remove the following components:
 - ❑ Optical drive ([Section 5.8](#))
 - ❑ Switch cover ([Section 5.9](#))
 - ❑ Keyboard ([Section 5.10](#))
 - ❑ Display assembly ([Section 5.11](#))
 - ❑ Base enclosure ([Section 5.12](#))

2. Disconnect the speaker cable ❶ from the system board.
3. Lift the speaker ❷ straight up to remove it from the top cover.

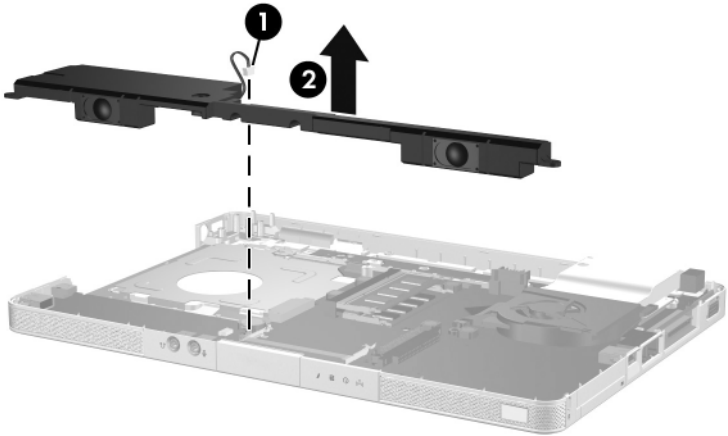

Removing the Speaker Assembly

Reverse the above procedure to install the speaker assembly.

5.16 RTC Battery

RTC Battery Spare Part Number Information

RTC battery

412390-001

1. Prepare the computer for disassembly ([Section 5.3](#)) and remove the following components:
 - ❑ Optical drive ([Section 5.8](#))
 - ❑ Switch cover ([Section 5.9](#))
 - ❑ Keyboard ([Section 5.10](#))
 - ❑ Display assembly ([Section 5.11](#))
 - ❑ Base enclosure ([Section 5.12](#))

2. Remove the RTC battery from the socket on the system board.

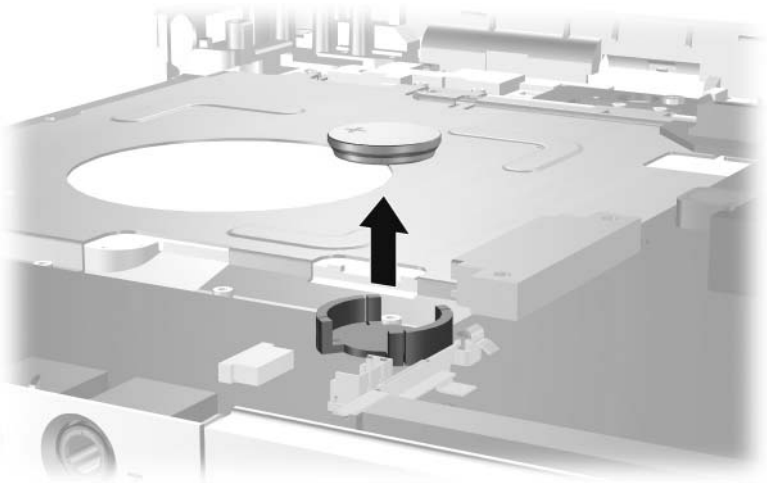

Removing the RTC Battery

Reverse the above procedure to install the RTC battery. Be sure that the RTC battery is installed with the “+” sign facing up.

5.17 Fan/Heat Sink Assembly

Fan/Heat Sink Assembly Spare Part Number Information

Fan/heat sink assembly (includes thermal pad)	412397-001
---	------------

1. Prepare the computer for disassembly ([Section 5.3](#)) and remove the following components:
 - ❑ Optical drive ([Section 5.8](#))
 - ❑ Switch cover ([Section 5.9](#))
 - ❑ Keyboard ([Section 5.10](#))
 - ❑ Display assembly ([Section 5.11](#))
 - ❑ Base enclosure ([Section 5.12](#))
2. Turn the computer upside down with the front toward you.

3. Disconnect the fan cable **1** from the system board.
4. Loosen the four Phillips PM2.5×5.0 screws **2** that secure the fan/heat sink assembly to the top cover.
5. Remove the fan/heat sink assembly **3**.

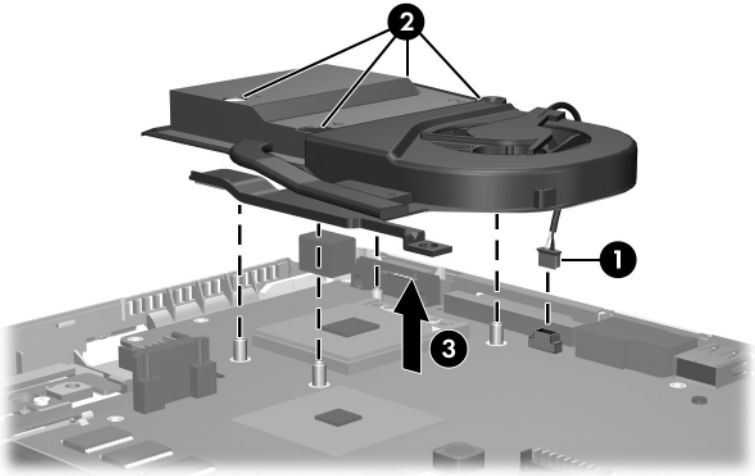

Removing the Fan/Heat Sink Assembly

Reverse the above procedure to install the fan/heat sink assembly.

5.18 Processor

Processor Spare Part Number Information

Intel Core Duo T2500 (2.00-GHz)	412333-001
Intel Core Duo T2400 (1.83-GHz)	412334-001
Intel Core Duo T2300 (1.66-GHz)	412335-001
Intel Core Solo T1300 (1.66-GHz)	412332-001

1. Prepare the computer for disassembly ([Section 5.3](#)) and remove the following components:
 - ❑ Optical drive ([Section 5.8](#))
 - ❑ Switch cover ([Section 5.9](#))
 - ❑ Keyboard ([Section 5.10](#))
 - ❑ Display assembly ([Section 5.11](#))
 - ❑ Base enclosure ([Section 5.12](#))
 - ❑ Fan/heat sink assembly([Section 5.17](#))

2. Turn the processor locking screw **1** one-half turn counterclockwise until you feel a click.
3. Lift the processor **2** straight up and remove it.



The gold triangle **3** on the processor should be aligned in the front right corner when you install the processor.

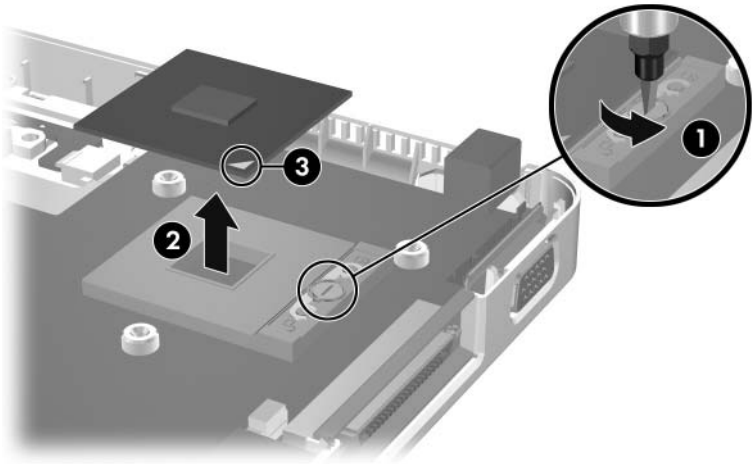

Removing the Processor

Reverse the above procedure to install a processor.

5.19 System Board

System Board Spare Part Number Information

945GM

412240-001



When replacing the system board, ensure that the following components are removed from the defective system board and installed on the replacement system board:

- Memory modules ([Section 5.6](#))
 - Mini Card module ([Section 5.7](#))
 - RTC battery ([Section 5.16](#))
 - Fan/heat sink assembly ([Section 5.17](#))
 - Processor ([Section 5.18](#))
-

1. Prepare the computer for disassembly ([Section 5.3](#)) and remove the following components:
 - ❑ Hard drive ([Section 5.4](#))
 - ❑ Optical drive ([Section 5.8](#))
 - ❑ Switch cover ([Section 5.9](#))
 - ❑ Keyboard ([Section 5.10](#))
 - ❑ Display assembly ([Section 5.11](#))
 - ❑ Base enclosure ([Section 5.12](#))
 - ❑ USB/S-Video board ([Section 5.13](#))
 - ❑ Speaker assembly ([Section 5.15](#))
2. Turn the top cover right side up with the front toward you.
3. Release the ZIF connector ❶ to which the TouchPad cable is connected and disconnect the cable ❷ from the system board.

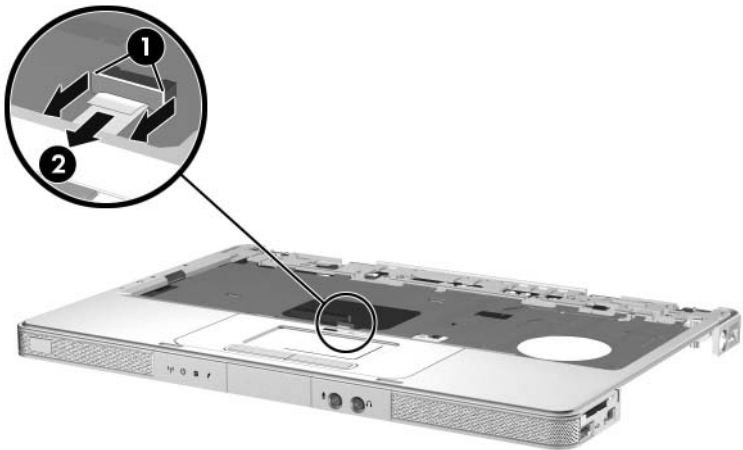

Disconnecting the TouchPad Cable

4. Turn the top cover upside down with the front toward you.
5. Release the ZIF connector **1** to which the LED board cable is connected and disconnect the cable **2** from the system board.
6. Remove the three silver Phillips PM2.0×5.0 screws **3** that secure the system board to the top cover.

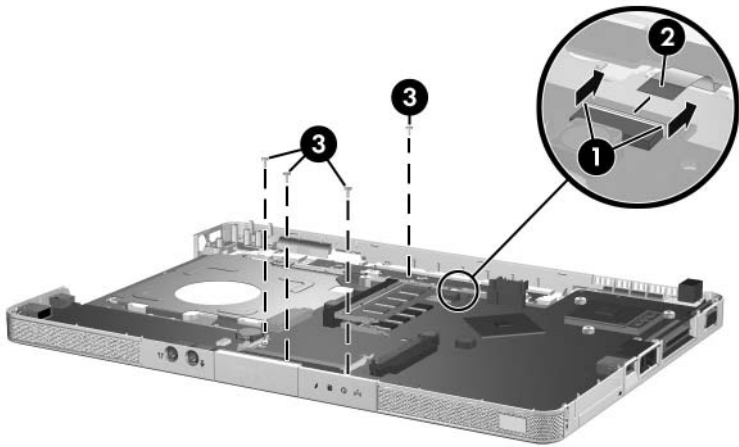

Disconnecting the LED Board Cable and Removing the System Board Screws

7. Flex and hold the left side of the top cover ❶.
8. Lift the left side of the system board ❷ until the USB ❸ and 1394 connectors ❹ clear the top cover.

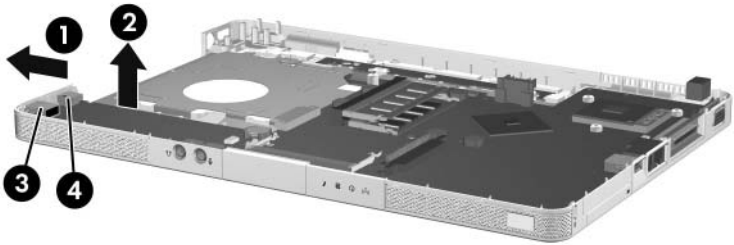

Releasing the System Board, Part 1

9. Flex and hold the front edge of the top cover **1**.
10. Lift the system board **2** until the audio connectors **3** clear the top cover.

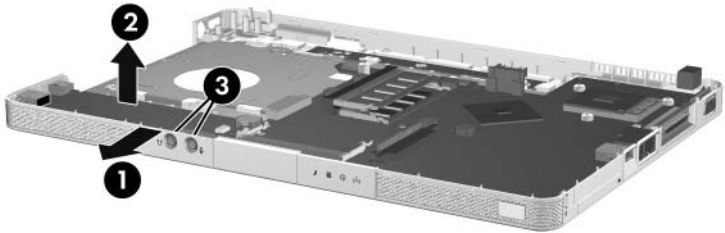

Releasing the System Board, Part 2

11. Slide the system board to the left at an angle and remove it from the top cover.

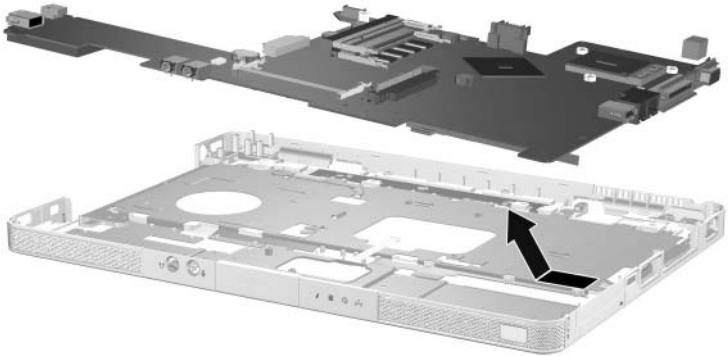

Removing the System Board

Reverse the above procedure to install the system board.

5.20 LED Board

LED Board Spare Part Number Information

LED board

412400-001

1. Prepare the computer for disassembly ([Section 5.3](#)) and remove the following components:
 - ❑ Optical drive ([Section 5.8](#))
 - ❑ Switch cover ([Section 5.9](#))
 - ❑ Keyboard ([Section 5.10](#))
 - ❑ Display assembly ([Section 5.11](#))
 - ❑ Base enclosure ([Section 5.12](#))
 - ❑ USB/S-Video board ([Section 5.13](#))
 - ❑ Speaker assembly ([Section 5.15](#))
 - ❑ System board ([Section 5.19](#))

2. Turn the computer upside down with the front panel toward you.

3. Release the ZIF connector ❶ to which the LED board cable is connected and disconnect the cable ❷ from the system board.
4. Remove the two Phillips PM2.0×3.0 screws ❸ that secure the LED board to the top cover.

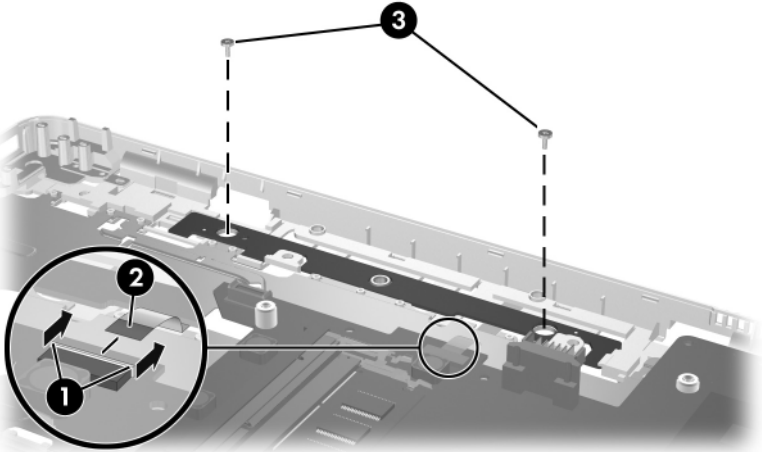

Removing the LED Board Screws

5. Remove the LED board.
- Reverse the above procedure to install the LED board.

5.21 ExpressCard Assembly

ExpressCard Assembly Spare Part Number Information

ExpressCard assembly

412331-001

1. Prepare the computer for disassembly ([Section 5.3](#)) and remove the following components:
 - ❑ Optical drive ([Section 5.8](#))
 - ❑ Switch cover ([Section 5.9](#))
 - ❑ Keyboard ([Section 5.10](#))
 - ❑ Display assembly ([Section 5.11](#))
 - ❑ Base enclosure ([Section 5.12](#))
 - ❑ USB/S-Video board ([Section 5.13](#))
 - ❑ Speaker assembly ([Section 5.15](#))
 - ❑ System board ([Section 5.19](#))
2. Turn the computer upside down with the ExpressCard eject button toward you.

3. Remove the two Phillips PM2.0×2.0 screws that secure the ExpressCard assembly to the system board.

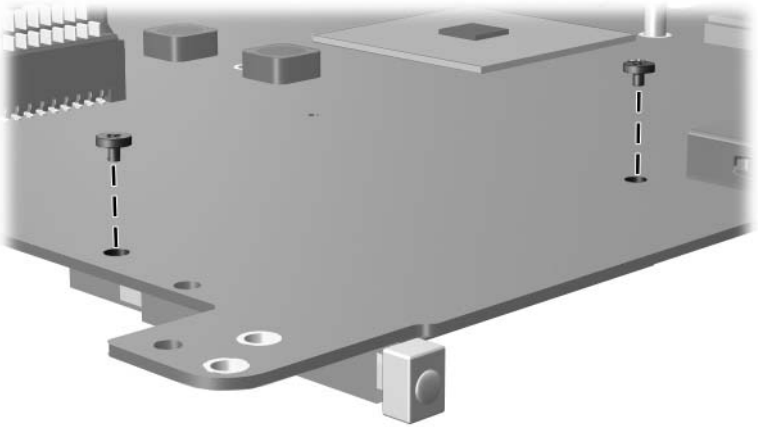

Removing the ExpressCard Assembly Screws

4. Turn the system board right side up with the ExpressCard eject button toward you.
5. Lift the back of the ExpressCard assembly to disconnect it from the system board.

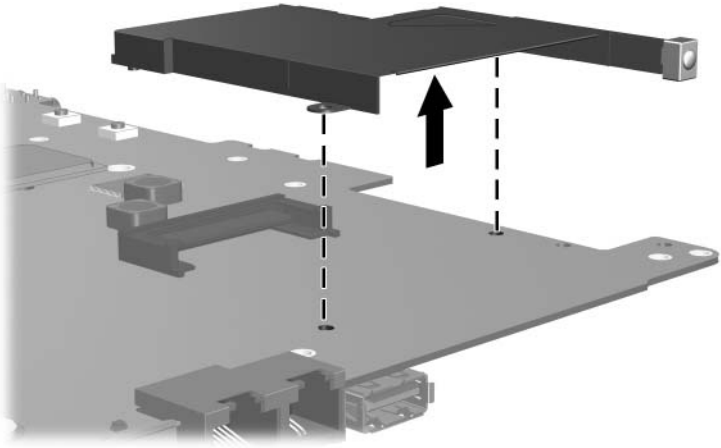

Removing the ExpressCard Assembly

Reverse the above procedure to install the ExpressCard assembly.

6

Specifications

This chapter provides physical and performance specifications.

Table 6-1
Computer

Dimensions		
Height (varies from front to back)	3.29 cm to 3.89 cm	1.30 in to 1.53 in
Width	23.06 cm	9.08 in
Depth	33.40 cm	13.15 in
Weight (varies by configuration)	2.39 kg	5.26 lb
Stand-alone power requirements		
Operating voltage	18.5 V dc to 19.0 V dc	
Operating current	3.5 A or 4.74 A	
Peak operating power	65 W	
Temperature		
Operating*	10°C to 35°C	50°F to 95°F
Nonoperating	-20°C to 60°C	-4°F to 140°F
Relative humidity (noncondensing)		
Operating	10% to 90%	
Nonoperating	5% to 95%, 38.7°C (101.6°F) maximum wet bulb temperature	
Maximum altitude (unpressurized)		
Operating (14.7 to 10.1 psia)	-15 m to 3,048 m	-50 ft to 10,000 ft
Nonoperating (14.7 to 4.4 psia)	-15 m to 12,192 m	-50 ft to 40,000 ft

Table 6-1
Computer (Continued)

Shock

Operating	125 g, 2 ms, half-sine
Nonoperating	200 g, 2 ms, half-sine

Random Vibration

Operating	0.75 g zero-to-peak, 10 Hz to 500 Hz, 0.25 oct/min sweep rate
Nonoperating	1.50 g zero-to-peak, 10 Hz to 500 Hz, 0.5 oct/min sweep rate



Applicable product safety standards specify thermal limits for plastic surfaces. The computer operates well within this range of temperatures.

Table 6-2
14.0-inch, WXGA, SVA Display

Dimensions		
Height	27.94 cm	11.0 in
Width	20.83 cm	8.2 in
Diagonal	35.56 cm	14.0 in
Number of colors	Up to 16.8 million	
Contrast ratio	250:1	
Brightness	180 nits typical	
Pixel resolution		
Pitch	0.279 × 0.279 mm	
Format	1280 × 768	
Configuration	RGB vertical stripe	
Backlight	Edge lit	
Character display	80 × 25	
Total power consumption	4 W	
Viewing angle	+/-40° horizontal, +20/-40° vertical typical	

Table 6-3
Hard Drives

	80-GB	60-GB	60-GB	40-GB
Dimensions				
Height	9.5 mm	9.5 mm	9.5 mm	9.5 mm
Width	70 mm	70 mm	70 mm	70 mm
Weight	99 g	102 g	99 g	99 g
Interface type	ATA-5	ATA-5	ATA-5	ATA-5
Transfer rate				
Synchronous (maximum)	100 MB/sec	100 MB/sec	100 MB/sec	100 MB/sec
Security	ATA security	ATA security	ATA security	ATA security
Seek times (typical read, including setting)				
Single track	3 ms	3 ms	3 ms	3 ms
Average	13 ms	13 ms	13 ms	13 ms
Maximum	24 ms	24 ms	24 ms	24 ms
Logical blocks [†]	156,301,488	117,210,240	117,210,240	78,140,160
Disk rotational speed	5400 rpm	5400 rpm	4200 rpm	4200 rpm
Operating temperature	5°C to 55°C (41°F to 131°F)			



Certain restrictions and exclusions apply. Consult Customer Care for details.

*1 GB = 1 billion bytes when referring to hard drive storage capacity. Accessible capacity is less.

[†]Actual drive specifications may differ slightly.

Table 6-4
Primary 6-cell, Li-Ion Battery Pack

Dimensions

Height	2.00 cm	0.79 in
Width	9.40 cm	3.70 in
Depth	13.40 cm	5.28 in
Weight	0.34 kg	0.75 lb

Energy

Voltage	11.1 V
Amp-hour capacity	4.4 Ah
Watt-hour capacity	48 Wh

Temperature

Operating	5°C to 45°C	41°F to 113°F
Nonoperating	0°C to 60°C	32°F to 140°F

Table 6-5
DVD/CD-RW Combo Drive

Applicable disc	Read:	Write:
	DVD-R, DVD-RW, DVD-ROM (DVD-5, DVD-9, DVD-10, DVD-18), CD-ROM (Mode 1 and 2) CD Digital Audio CD-XA ready (Mode 2, Form 1 and 2) CD-I ready (Mode 2, Form 1 and 2) CD-R, CD-RW Photo CD (single and multisession) CD-Bridge	CD-R and CD-RW
Center hole diameter	1.5 cm (0.59 in)	
Disc diameter		
Standard disc	12 cm (4.72 in)	
Mini disc	8 cm (3.15 in)	

Table 6-5
DVD/CD-RW Combo Drive (Continued)

Disc thickness	1.2 mm (0.047 in)	
Track pitch	0.74 μ m	
Access time	CD media	DVD media
Random	< 110 ms	< 130 ms
Full stroke	< 210 ms	< 225 ms
Audio output level	Line-out, 0.7 V rms	
Cache buffer	2 MB	
Data transfer rate		
CD-R (24X)	3600 KB/s (150 KB/s at 1X CD rate)	
CD-RW (10X)	1500 KB/s (150 KB/s at 1X CD rate)	
CD-ROM (24X)	3600 KB/s (150 KB/s at 1X CD rate)	
DVD (8X)	10,800 KB/s (1352 KB/s at 1X DVD rate)	
Multiword DMA mode 2	16.6 MB/s	
Startup time	< 15 seconds	
Stop time	< 6 seconds	

Table 6-6
DVD±RW/R and
CD-RW Double-Layer Combo Drive

Applicable disc	Read:	Write:
	DVD-R, DVD-RW, DVD-ROM (DVD-5, DVD-9, DVD-10, DVD-18), CD-ROM (Mode 1 and 2) CD Digital Audio CD-XA ready (Mode 2, Form 1 and 2) CD-I ready (Mode 2, Form 1 and 2) CD-R, CD-RW Photo CD (single and multisession) CD-Bridge	CD-R and CD-RW DVD-R and DVD-RW
Center hole diameter	1.5 cm (0.59 in)	
Disc diameter		
Standard disc	12 cm (4.72 in)	
Mini disc	8 cm (3.15 in)	

Table 6-6
DVD±RW/R and
CD-RW Double-Layer Combo Drive (Continued)

Disc thickness	1.2 mm (0.047 in)	
Track pitch	0.74 μm	
Access time	CD media	DVD media
Random	< 175 ms	< 230 ms
Full stroke	< 285 ms	< 335 ms
Audio output level	Audio-out, 0.7 Vrms	
Cache buffer	2 MB	
Data transfer rate		
CD-R (16X)	2,400 KB/s (150 KB/s at 1X CD rate)	
CD-RW (8X)	1,200 KB/s (150 KB/s at 1X CD rate)	
CD-ROM (24X)	3,600 KB/s (150 KB/s at 1X CD rate)	
DVD (8X)	10,800 KB/s (1,352 KB/s at 1X DVD rate)	
DVD-R (4X)	5,400 KB/s (1,352 KB/s at 1X DVD rate)	
DVD-RW (2X)	2,700 KB/s (1,352 KB/s at 1X DVD rate)	
Multiword DMA mode 2	16.6 MB/s	
Startup time	< 15 seconds	
Stop time	< 6 seconds	

Table 6-7
System DMA

Hardware DMA	System Function
DMA0	Not applicable
DMA1	Not applicable
DMA2	Not applicable
DMA3	Not applicable
DMA4	Direct memory access controller
DMA5	Available for ExpressCard
DMA6	Not assigned
DMA7	Not assigned

Table 6-8
System Interrupts

Hardware IRQ	System Function
IRQ0	System timer
IRQ1	Quick Launch buttons
IRQ2	Cascaded
IRQ3	USB2 Enhanced Host Controller—24CD
IRQ4	COM1
IRQ5*	Conexant AC—Link Audio SMBus Controller—24C3 Data Fax Modem with SmartCP
IRQ6	Diskette drive
IRQ7*	Parallel port
IRQ8	System CMOS/real-time clock
IRQ9*	Microsoft ACPI-compliant system
IRQ10*	USB UHCI controller—24C2 GM/GME Graphic Controller Realtek RTL8139 Family PCI fast Ethernet Controller
IRQ11	USB EHCI controller—24CD USB UHCI controller—24C4 USB UHCI controller—24C7 Pro/Wireless 2200BG TI OHCI 1394 host controller TI PCI1410 CardBus controller

*Default configuration



ExpressCard may assert IRQ3, IRQ4, IRQ5, IRQ7, or IRQ20.

Table 6-8
System Interrupts (Continued)

Hardware IRQ	System Function
IRQ12	Synaptics PS/2 port pointing device
IRQ13	Numeric data processor
IRQ14	Primary IDE channel
IRQ15	Secondary IDE channel
IRQ17	Conexant AC -Link Audio
IRQ17	Soft V90 Data Fax Modem with SmartCP
IRQ17	ATi Mobility Radeon Xpress 200 Series
IRQ19	Standard Enhanced PCI to USB Host Controller
IRQ19	Standard OpenHCD USB Host Controller
IRQ19	Standard OpenHCD USB Host Controller
IRQ20	TI 6411 PC1xx21/x515 Cardbus Controller
IRQ20	TI OHCI Compliant IEEE 1394 Host Controller
IRQ21	TI Integrated PC1xx21 FlashMedia Controller
IRQ21	Broadcom 802.11b/g WLAN
IRQ21	Microsoft ACPI-compliant system
IRQ22	Realtek RTL8100CL Family PCI fast Ethernet Controller
IRQ23	SDA Standard Compliant SD Host Controller

*Default configuration



ExpressCard may assert IRQ3, IRQ4, IRQ5, IRQ7, or IRQ20.

Table 6-9
System I/O Addresses

I/O Address (hex)	System Function (shipping configuration)
0x00000000-0x00000CF7	PCI bus
0x00000000-0x00000CF7	Direct memory access controller
0x00000020-0x00000021	Programmable interrupt controller
0x0000002E-0x0000002F	System board resources
0x00000040-0x00000043	System timer
0x00000060-0x00000060	Quick Launch Buttons
0x00000061-0x00000061	System speaker
0x00000062-0x00000062	Microsoft ACPI-Compliant Embedded Controller
0x00000064-0x00000064	Quick Launch Buttons
0x00000066-0x00000066	Microsoft ACPI-Compliant Embedded Controller
0x00000070-0x00000071	System CMOS/real time clock
0x00000072-0x00000073	System board resources
0x00000080-0x0000008F	Direct memory access controller
0x00000092-0x00000092	System board resources
0x000000A0-0x000000A1	Programmable interrupt controller
0x000000B0-0x000000B1	System board resources
0x000000C0-0x000000DF	Direct memory access controller
0x000000F0-0x000000FE	Numeric data processor
0x00000170-0x00000177	Secondary IDE Channel

Table 6-9
System I/O Addresses (Continued)

I/O Address (hex)	System Function (shipping configuration)
0x000001F0-0x000001F7	Primary IDE Channel
0x00000220-0x0000022F	System board resources
0x00000274-0x00000277	ISAPNP Read Data Port
0x00000279-0x00000279	ISAPNP Read Data Port
0x00000280-0x00000293	System board resources
0x00000376-0x00000376	Secondary IDE Channel
0x000003B0-0x000003BB	PCI standard PCI-to-PCI bridge
0x000003B0-0x000003BB	ATI MOBILITY RADEON Xpress 200 Series
0x000003C0-0x000003DF	PCI standard PCI-to-PCI bridge
0x000003C0-0x000003DF	ATI MOBILITY RADEON Xpress 200 Series
0x000003F6-0x000003F6	Primary IDE Channel
0x0000040B-0x0000040B	System board resources
0x000004D0-0x000004D1	System board resources
0x000004D6-0x000004D6	System board resources
0x00000530-0x00000537	System board resources
0x00000870-0x0000087F	System board resources
0x00000A79-0x00000A79	ISAPNP Read Data Port
0x00000C00-0x00000C01	System board resources
0x00000C14-0x00000C14	System board resources
0x00000C50-0x00000C52	System board resources
0x00000C6C-0x00000C6C	System board resources

Table 6-9
System I/O Addresses (Continued)

I/O Address (hex)	System Function (shipping configuration)
0x00000C6F-0x00000C6F	System board resources
0x00000CD4-0x00000CD5	System board resources
0x00000CD6-0x00000CD7	System board resources
0x00000CD8-0x00000CDF	System board resources
0x00000D00-0x0000FFFF	PCI bus
0x00000F40-0x00000F47	System board resources
0x00001080-0x00001080	System board resources
0x00008000-0x0000805F	System board resources
0x00008100-0x000081FF	System board resources
0x00008400-0x0000840F	ATI SMBus
0x00008410-0x0000841F	Standard Dual Channel PCI IDE Controller
0x00009000-0x00009FFF	PCI standard PCI-to-PCI bridge
0x00009000-0x00009FFF	ATI MOBILITY RADEON Xpress 200 Series
0x0000A000-0x0000A0FF	Realtek RTL8139/810x Family Fast Ethernet NIC
0x0000F000-0x0000FFFF	PCI standard PCI-to-PCI bridge
0x0000FD00-0x0000FDFF	Texas Instruments PCIE/x21/x515 Cardbus Controller
0x0000FE00-0x0000FEFF	Texas Instruments PCIE/x21/x515 Cardbus Controller

Table 6-10
System Memory Map

Memory Map Address (hex)	System Function (shipping configuration)
0xD4100000-0xD41FFFFFF	PCI standard PCI-to-PCI bridge
0xD4100000-0xD41FFFFFF	ATI MOBILITY RADEON Xpress 200 Series
0xD8000000-0xDBFFFFFFF	PCI standard PCI-to-PCI bridge
0xD8000000-0xDBFFFFFFF	ATI MOBILITY RADEON Xpress 200 Series
0xFAC00000-0xFEBFFFFFF	PCI standard PCI-to-PCI bridge
0xF6C00000-0xFABFFFFFF	PCI standard PCI-to-PCI bridge
0xD4000000-0xD400FFF	Standard OpenHCD USB Host Controller
0xD4001000-0xD4001FFF	Standard OpenHCD USB Host Controller
0xD4002000-0xD4002FFF	Standard Enhanced PCI to USB Host Controller
0xD4003000-0xD40033FF	ATI SMBus
0xFFFF80000-0xFFFFFFFF	System board
0xE0000000-0xE03FFFFFF	System board
0xE0000000-0xE03FFFFFF	System board resources
0x0000-0x0FFF	System board

Table 6-10
System Memory Map (Continued)

Memory Map Address (hex)	System Function (shipping configuration)
0xD4208000-0xD42087FF	Texas Instruments OHCI Compliant IEEE 1394 Host Controller
0xD4200000-0xD4203FFF	Texas Instruments OHCI Compliant IEEE 1394 Host Controller
0xD4204000-0xD4205FFF	Broadcom 802.11b/g WLAN
0xFFE00000-0xFFE00000	Texas Instruments PCIxx21/x515 Cardbus Controller
0xFFE00000-0xFFE00000	Texas Instruments PCIxx21/x515 Cardbus Controller
0xF2C00000-0xF6BFFFFF	Texas Instruments PCIxx21/x515 Cardbus Controller
0xD4206000-0xD4207FFF	Texas Instruments PCIxx21 Integrated FlashMedia Controller
0xD4209000-0xD42090FF	SDA Standard Compliant SD Host Controller
0xD4208C00-0xD4208CFF	SDA Standard Compliant SD Host Controller
0xD4208800-0xD42088FF	SDA Standard Compliant SD Host Controller

Table 6-10
System Memory Map (Continued)

Memory Map Address (hex)	System Function (shipping configuration)
0xD4209400-0xD42094FF	Realtek RTL8139/810x Family Fast Ethernet NIC
0xD4003400-0xD40034FF	Conexant AC-Link Audio
0xD4003800-0xD40038FF	SoftV90 Data Fax Modem with SmartCP
0xFEC00000-0xFEC00FFF	System board resources
0xFEE00000-0xFEE00FFF	System board resources
0xA0000-0xBFFFF	PCI bus
0xA0000-0xBFFFF	PCI standard PCI-to-PCI bridge
0xA0000-0xBFFFF	ATI MOBILITY RADEON Xpress 200 Series
0xD6000-0xD7FFF	PCI bus
0xDC000-0xDDFFF	PCI bus
0xDD000-0xDDFFF	Texas Instruments PCIxx21/x515 Cardbus Controller
0xE0000-0xFFFFF	System board
0x40000000-0xFFFFFFFF	PCI bus

A

Connector Pin Assignments

Table A-1
Universal Serial Bus

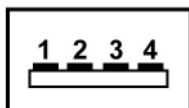

Pin	Signal	Pin	Signal
1	+5 VDC	3	Data +
2	Data -	4	Ground

Table A-2
RJ-45 (Network)

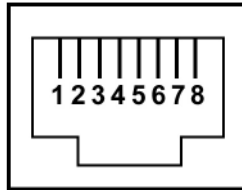

Pin	Signal	Pin	Signal
1	Transmit +	5	Unused
2	Transmit –	6	Receive –
3	Receive +	7	Unused
4	Unused	8	Unused

Table A-3
S-Video-Out



Pin	Signal	Pin	Signal
1	TV-Ground	5	TV-CD
2	TV-CVBS	6	TV-Ground
3	TV-Ground	7	TV-YD
4	TV-Ground		

Table A-4
External Monitor

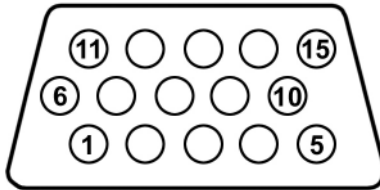

Pin	Signal	Pin	Signal
1	Red analog	9	+5 VDC
2	Green analog	10	Ground
3	Blue analog	11	Monitor detect
4	Not connected	12	DDC 2B data
5	Ground	13	Horizontal sync
6	Ground analog	14	Vertical sync
7	Ground analog	15	DDC 2B clock
8	Ground analog		

Table A-5
RJ-11 (Modem)

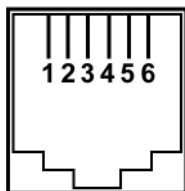

Pin	Signal	Pin	Signal
1	Unused	4	Unused
2	Tip	5	Unused
3	Ring	6	Unused

Table A-6
Audio-In (Microphone)

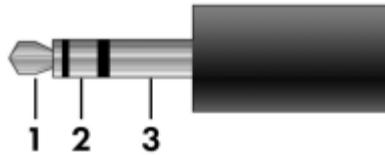

Pin	Signal	Pin	Signal
1	Audio signal in	3	Ground
2	Audio signal in		

Table A-7
Audio-Out (Headphone)

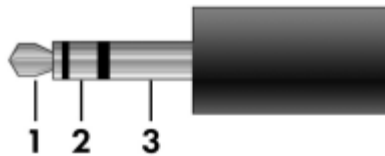

Pin	Signal	Pin	Signal
1	Audio out, left channel	3	Ground
2	Audio out, right channel		

Power Cord Set Requirements

3-Conductor Power Cord Set

The wide range input feature of the computer permits it to operate from any line voltage from 100 to 120 or 220 to 240 volts AC.

The power cord set included with the computer meets the requirements for use in the country where the equipment is purchased.

Power cord sets for use in other countries must meet the requirements of the country where the computer is used.

General Requirements

The requirements listed below are applicable to all countries.

- The length of the power cord set must be at least 1.5 m (5.0 ft) and a maximum of 2.0 m (6.5 ft).
- All power cord sets must be approved by an acceptable accredited agency responsible for evaluation in the country where the power cord set will be used.
- The power cord sets must have a minimum current capacity of 10 amps and a nominal voltage rating of 125 or 250 V AC, as required by each country's power system.
- The appliance coupler must meet the mechanical configuration of an EN 60 320/IEC 320 Standard Sheet C13 connector for mating with the appliance inlet on the back of the computer.

Country-Specific Requirements

3-Conductor Power Cord Set Requirements

Country/Region	Accredited Agency	Applicable Note Number
Australia	EANSW	1
Austria	OVE	1
Belgium	CEBC	1
Canada	CSA	2
Denmark	DEMKO	1
Finland	FIMKO	1
France	UTE	1
Germany	VDE	1
Italy	IMQ	1
Japan	METI	3

Notes:

1. The flexible cord must be <HAR> Type HO5VV-F, 3-conductor, 1.0 mm² conductor size. Power cord set fittings (appliance coupler and wall plug) must bear the certification mark of the agency responsible for evaluation in the country where it will be used.
2. The flexible cord must be Type SPT-3 or equivalent, No. 18 AWG, 3-conductor. The wall plug must be a two-pole grounding type with a NEMA 5-15P (15 A, 125 V) or NEMA 6-15P (15 A, 250 V) configuration.
3. The appliance coupler, flexible cord, and wall plug must bear a “T” mark and registration number in accordance with the Japanese Dentori Law. The flexible cord must be Type VCT or VCTF, 3-conductor, 1.00 mm² conductor size. The wall plug must be a two-pole grounding type with a Japanese Industrial Standard C8303 (7 A, 125 V) configuration.

3-Conductor Power Cord Set Requirements (*Continued*)

Country/Region	Accredited Agency	Applicable Note Number
Korea	EK	4
The Netherlands	KEMA	1
Norway	NEMKO	1
People's Republic of China	CCC	5
Sweden	SEMKO	1
Switzerland	SEV	1
Taiwan	BSMI	4
United Kingdom	BSI	1
United States	UL	2

Notes:

1. The flexible cord must be <HAR> Type HO5VV-F, 3-conductor, 1.0 mm² conductor size. Power cord set fittings (appliance coupler and wall plug) must bear the certification mark of the agency responsible for evaluation in the country where it will be used.
 2. The flexible cord must be Type SPT-3 or equivalent, No. 18 AWG, 3-conductor. The wall plug must be a two-pole grounding type with a NEMA 5-15P (15 A, 125 V) or NEMA 6-15P (15 A, 250 V) configuration.
 3. The appliance coupler, flexible cord, and wall plug must bear a "T" mark and registration number in accordance with the Japanese Dentori Law. The flexible cord must be Type VCT or VCTF, 3-conductor, 1.00 mm² conductor size. The wall plug must be a two-pole grounding type with a Japanese Industrial Standard C8303 (7 A, 125 V) configuration.
 4. The flexible cord must be Type RVV, 3-conductor, 0.75 mm² conductor size. Power cord set fittings (appliance coupler and wall plug) must bear the certification mark of the agency responsible for evaluation in the country where it will be used.
 5. The flexible cord must be Type VCTF, 3-conductor, 0.75 mm² conductor size. Power cord set fittings (appliance coupler and wall plug) must bear the certification mark of the agency responsible for evaluation in the country where it will be used.
-

Screw Listing

This appendix provides specification and reference information for the screws used in the computer. All screws listed in this appendix are available in the Screw Kit, spare part number 412387-001, and the Display Screw Kit, spare part number 417713-001.

Table C-1
Black Phillips PM2.0x5.0 Screw

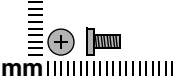
	Color	Qty.	Length	Thread	Head Width
mm	Black	11	5.0 mm	2.0 mm	4.0 mm

Where used:

- ① Two screws that secure the hard drive cover to the computer (screws are captured on the cover by C clips; documented in [Section 5.3](#))
- ② Two screws that secure the memory module compartment cover to the computer (screws are captured on the cover by C clips; documented in [Section 5.6](#))
- ③ One screw that secures the Mini Card compartment cover to the computer (screw is captured on the cover by a C clip; documented in [Section 5.7](#))

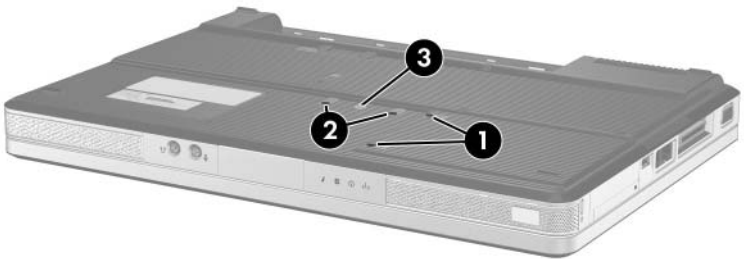

Black Phillips PM2.0x5.0 Screw Locations

Table C-1
Black Phillips PM2.0×5.0 Screw (Continued)

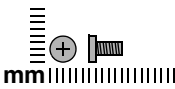
	Color	Qty.	Length	Thread	Head Width
	Black	11	5.0 mm	2.0 mm	4.0 mm

Where used:

2 screws that secure the Mini Card module to the computer (documented in [Section 5.7](#))

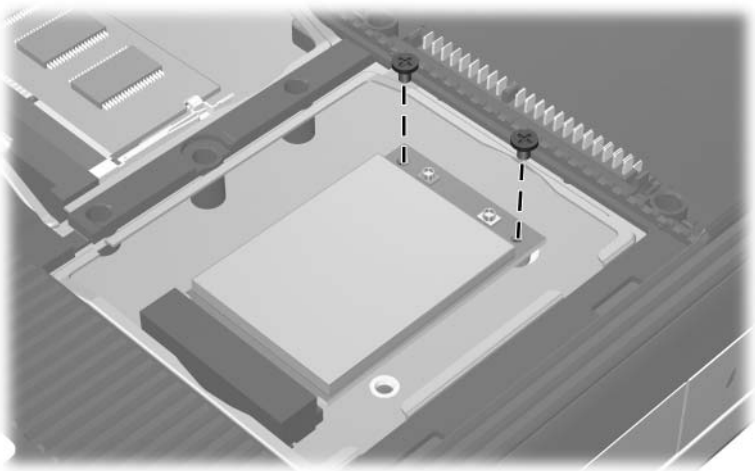

Black Phillips PM2.0×5.0 Screw Locations

Table C-1
Black Phillips PM2.0×5.0 Screw (Continued)

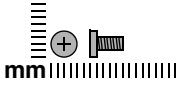

Color	Qty.	Length	Thread	Head Width
Black	11	5.0 mm	2.0 mm	4.0 mm

Where used:

4 screws that secure the display assembly to the computer (documented in [Section 5.11](#))



Black Phillips PM2.0×5.0 Screw Locations

Table C-2
Phillips PM2.5×4.0 Screw

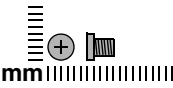
	Color	Qty.	Length	Thread	Head Width
	Silver	4	4.0 mm	2.5 mm	4.0 mm

Where used:

4 screws that secure the hard drive frame to the hard drive (documented in [Section 5.3](#))



Phillips PM2.5×4.0 Screw Locations

Table C-3
Phillips PM2.0x8.5 Screw

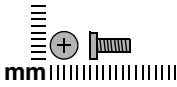

Color	Qty.	Length	Thread	Head Width
Black	16	8.5 mm	2.0 mm	4.0 mm

Where used:

One screw that secures the optical drive to the computer (documented in [Section 5.8](#))



Phillips PM2.0x8.5 Screw Location

Table C-3
Phillips PM2.0×8.5 Screw (Continued)

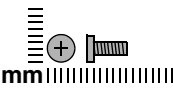
	Color	Qty.	Length	Thread	Head Width
	Black	16	8.5 mm	2.0 mm	4.0 mm

Where used:

15 screws that secure the base enclosure to the computer (documented in [Section 5.12](#))

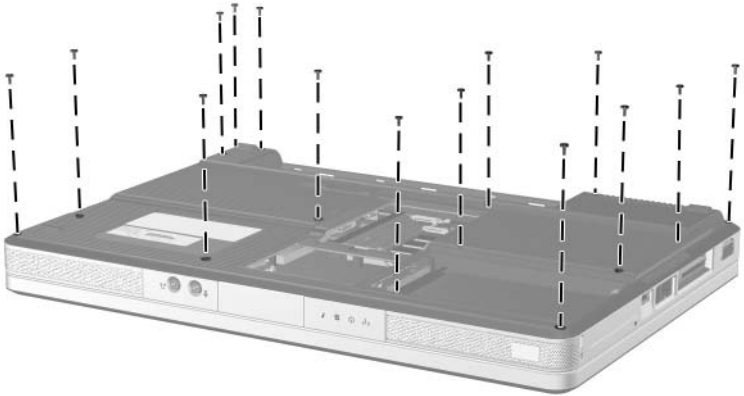

Phillips PM2.0×8.5 Screw Locations

Table C-4
Silver Phillips PM2.0x5.0 Screw

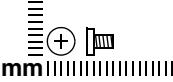
	Color	Qty.	Length	Thread	Head Width
mm	Silver	14	5.0 mm	2.0 mm	4.0 mm

Where used:

2 screws that secure the switch cover to the computer (documented in [Section 5.9](#))

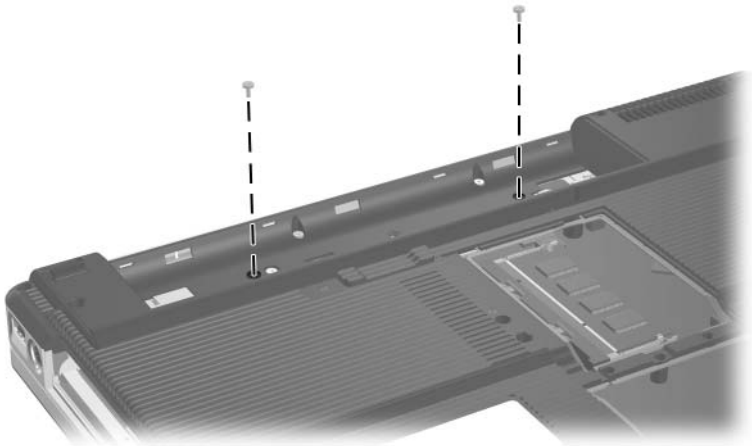

Silver Phillips PM2.0x5.0 Screw Locations

Table C-4

Silver Phillips PM2.0×5.0 Screw (*Continued*)

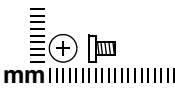
	Color	Qty.	Length	Thread	Head Width
	Silver	14	5.0 mm	2.0 mm	4.0 mm

Where used:

3 screws that secure the base enclosure to the computer (documented in [Section 5.12](#))

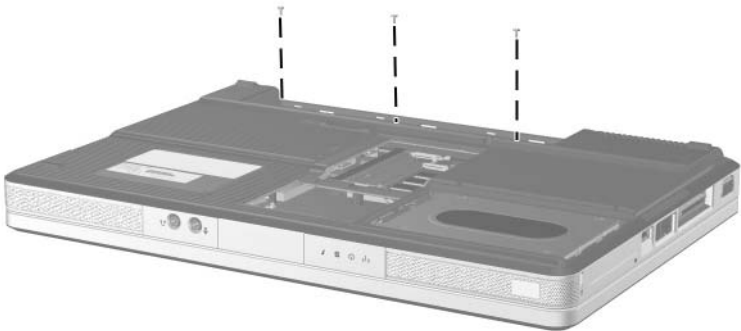

Silver Phillips PM2.0×5.0 Screw Locations

Table C-4

Silver Phillips PM2.0×5.0 Screw (Continued)

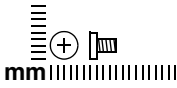

Color	Qty.	Length	Thread	Head Width
Silver	14	5.0 mm	2.0 mm	4.0 mm

Where used:

2 screws that secure the USB/S-Video board to the computer (documented in [Section 5.13](#))

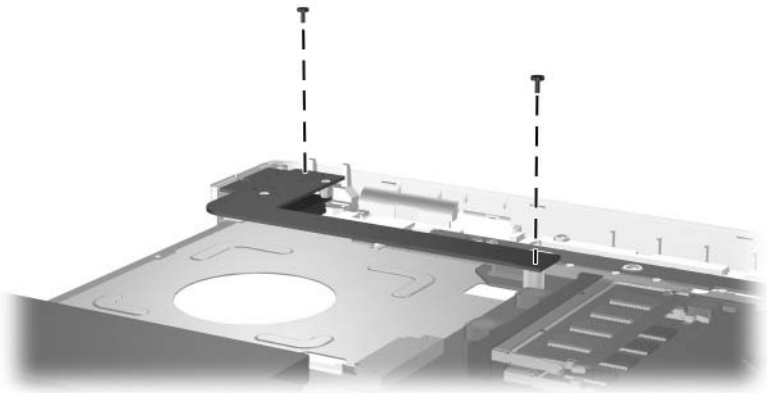

Silver Phillips PM2.0×5.0 Screw Locations

Table C-4

Silver Phillips PM2.0×5.0 Screw (*Continued*)

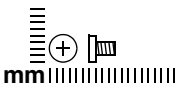
	Color	Qty.	Length	Thread	Head Width
	Silver	14	5.0 mm	2.0 mm	4.0 mm

Where used:

4 screws that secure the fan/heat sink assembly to the computer (documented in [Section 5.17](#))

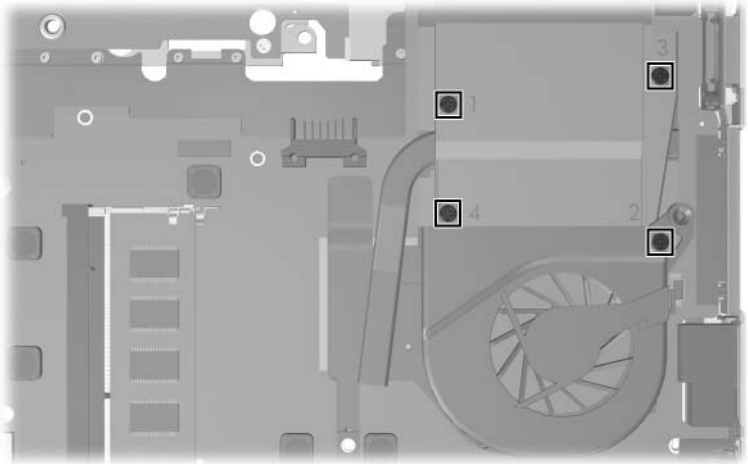

Silver Phillips PM2.0×5.0 Screw Locations

Table C-4
Silver Phillips PM2.0x5.0 Screw (Continued)

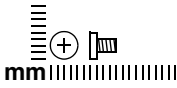

Color	Qty.	Length	Thread	Head Width
Silver	14	5.0 mm	2.0 mm	4.0 mm

Where used:

3 screws that secure the system board to the computer (documented in [Section 5.19](#))

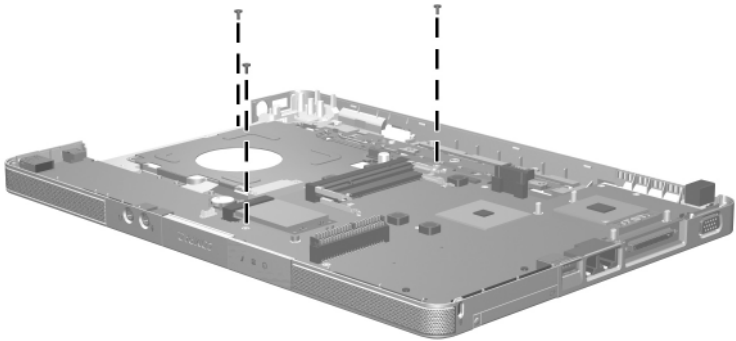

Silver Phillips PM2.0x5.0 Screw Locations

Table C-5
Phillips PM2.0×3.0 Screw

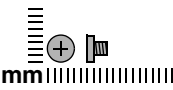
	Color	Qty.	Length	Thread	Head Width
	Black	15	3.0 mm	2.0 mm	4.0 mm

Where used:

4 screws that secure the keyboard to the computer (documented in [Section 5.10](#))



Phillips PM2.0×3.0 Screw Locations

Table C-5
Phillips PM2.0x3.0 Screw (Continued)

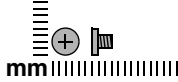
	Color	Qty.	Length	Thread	Head Width
	Black	15	3.0 mm	2.0 mm	4.0 mm

Where used:

One screw that secures the display inverter to the display assembly (documented in [Section 5.11](#))

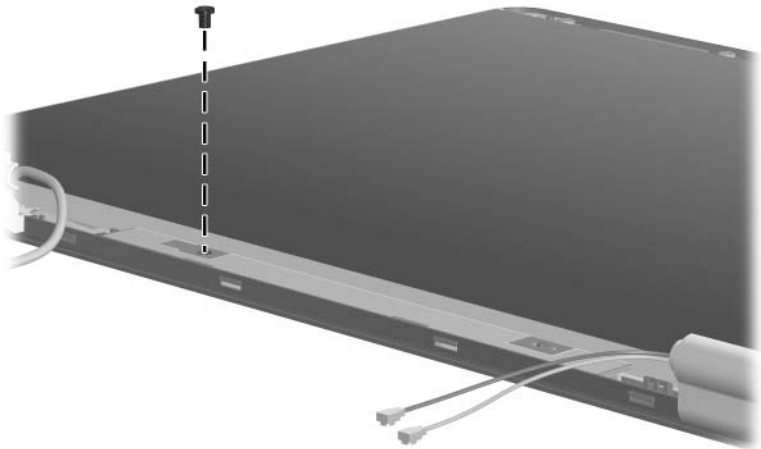

Phillips PM2.0x3.0 Screw Location

Table C-5
Phillips PM2.0x3.0 Screw (Continued)

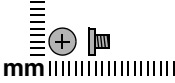
	Color	Qty.	Length	Thread	Head Width
mm	Black	15	3.0 mm	2.0 mm	4.0 mm

Where used:

4 screws that secure the display hinges to the display assembly (documented in [Section 5.11](#))



Phillips PM2.0x3.0 Screw Locations

Table C-5
Phillips PM2.0x3.0 Screw (Continued)

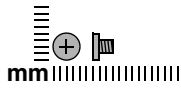
 mm	Color	Qty.	Length	Thread	Head Width
	Black	15	3.0 mm	2.0 mm	4.0 mm

Where used:

4 screws that secure the wireless antenna transceivers to the display enclosure (documented in [Section 5.20](#))

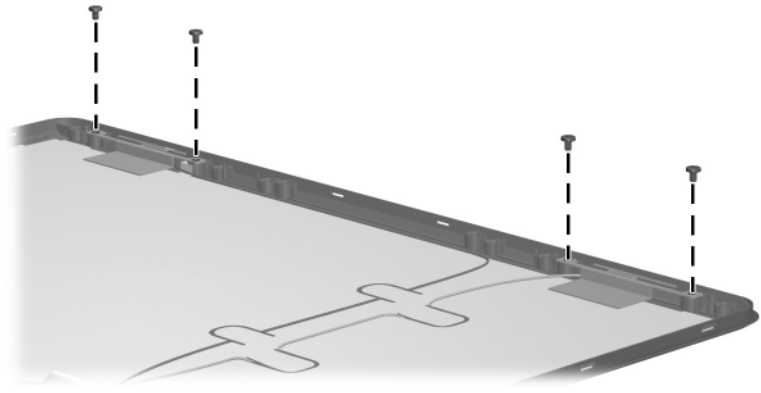

Phillips PM2.0x3.0 Screw Locations

Table C-5
Phillips PM2.0x3.0 Screw (Continued)

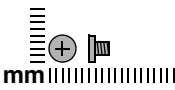
	Color	Qty.	Length	Thread	Head Width
	Black	15	3.0 mm	2.0 mm	4.0 mm

Where used:

2 screws that secure the LED board to the computer (documented in [Section 5.20](#))

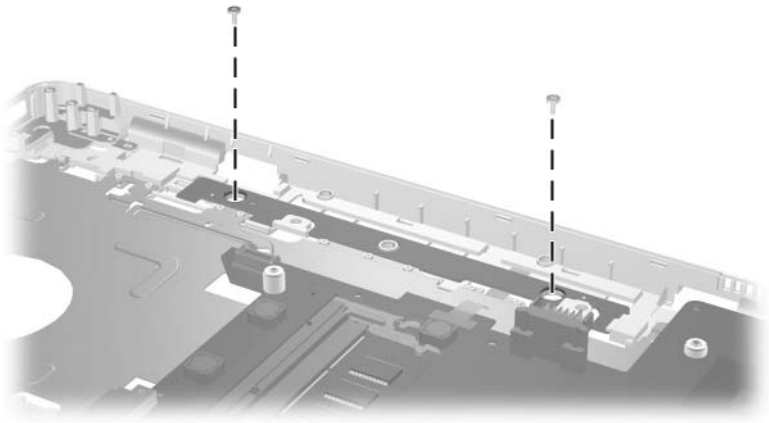

Phillips PM2.0x3.0 Screw Locations

Table C-6
Phillips PM1.5x3.5 Screw

 mm	Color	Qty.	Length	Thread	Head Width
	Silver	2	3.5 mm	1.5 mm	3.0 mm

Where used:

2 screws that secure the Bluetooth board to the USB/S-Video board (documented in [Section 5.14](#))

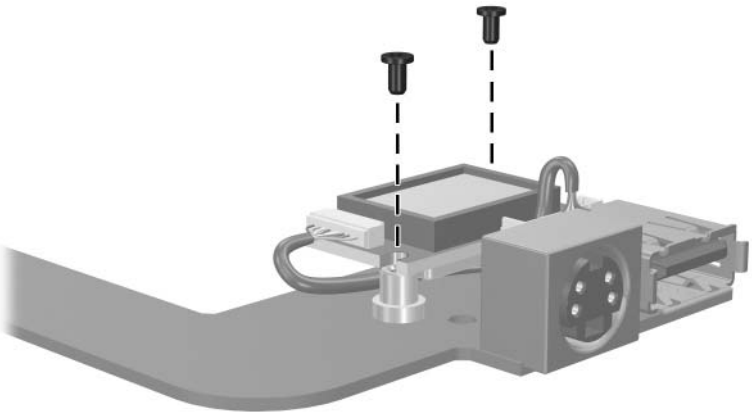

Phillips PM1.5x3.5 Screw Locations

Table C-7
Phillips PM2.0×2.0 Screw

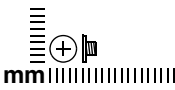
	Color	Qty.	Length	Thread	Head Width
mm	Silver	4	2.0 mm	2.0 mm	3.0 mm

Where used:

2 screws that secure the optical drive bracket to the optical drive (documented in [Section 5.8](#))

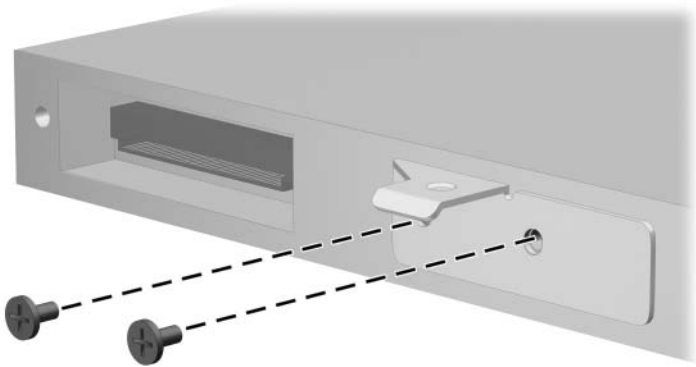

Phillips PM2.0×2.0 Screw Locations

Table C-7
Phillips PM2.0x2.0 Screw (Continued)

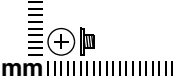
	Color	Qty.	Length	Thread	Head Width
	Silver	4	2.0 mm	2.0 mm	3.0 mm

Where used:

2 screws that secure the ExpressCard assembly to the system board (documented in [Section 5.21](#))

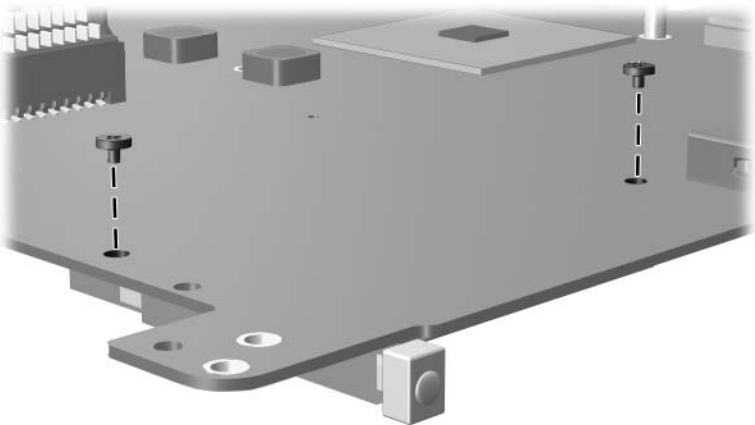

Phillips PM2.0x2.0 Screw Locations

Table C-8
Phillips PM2.5×6.0 Screw

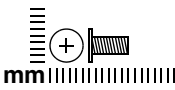
	Color	Qty.	Length	Thread	Head Width
	Silver	16	6.0 mm	2.5 mm	5.0 mm

Where used:

6 screws that secure the display bezel to the display assembly (documented in [Section 5.11](#))

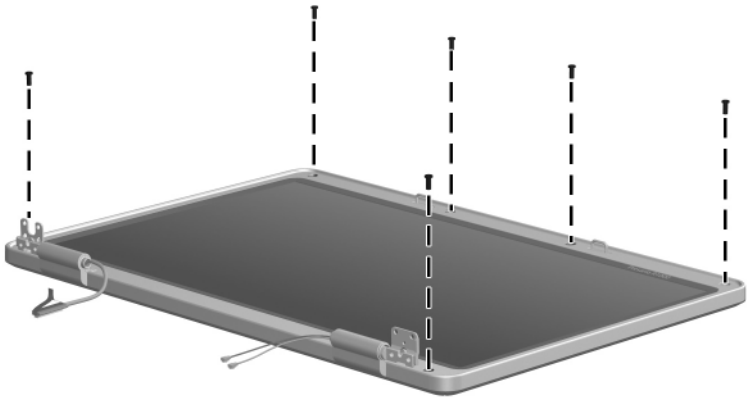

Phillips PM2.5×6.0 Screw Locations

Table C-8
Phillips PM2.5x6.0 Screw (Continued)

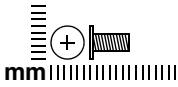

Color	Qty.	Length	Thread	Head Width
Silver	16	6.0 mm	2.5 mm	5.0 mm

Where used:

4 screws that secure the display release hooks to the display enclosure (documented in [Section 5.11](#))

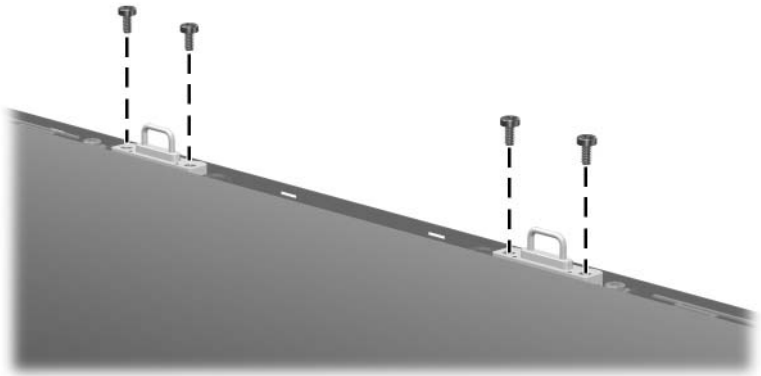

Phillips PM2.5x6.0 Screw Locations

Table C-8
Phillips PM2.5×6.0 Screw (Continued)

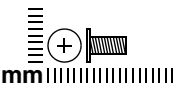
	Color	Qty.	Length	Thread	Head Width
	Silver	16	6.0 mm	2.5 mm	5.0 mm

Where used:

4 screws that secure the display hinge covers to the display enclosure (documented in [Section 5.11](#))

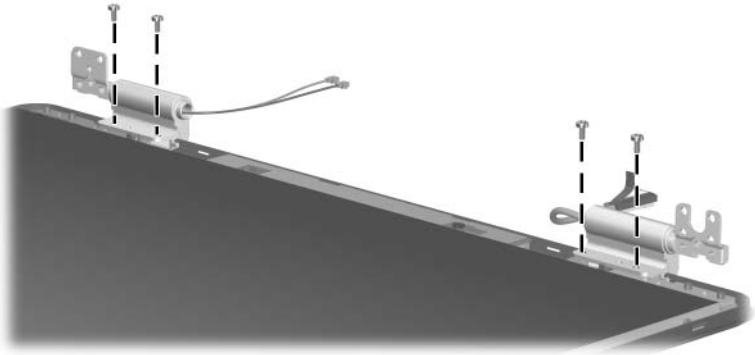

Phillips PM2.5×6.0 Screw Locations

Table C-8
Phillips PM2.5x6.0 Screw (Continued)

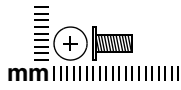
	Color	Qty.	Length	Thread	Head Width
	Silver	16	6.0 mm	2.5 mm	5.0 mm

Where used:

2 screws that secure the display panel to the display enclosure (documented in [Section 5.11](#))

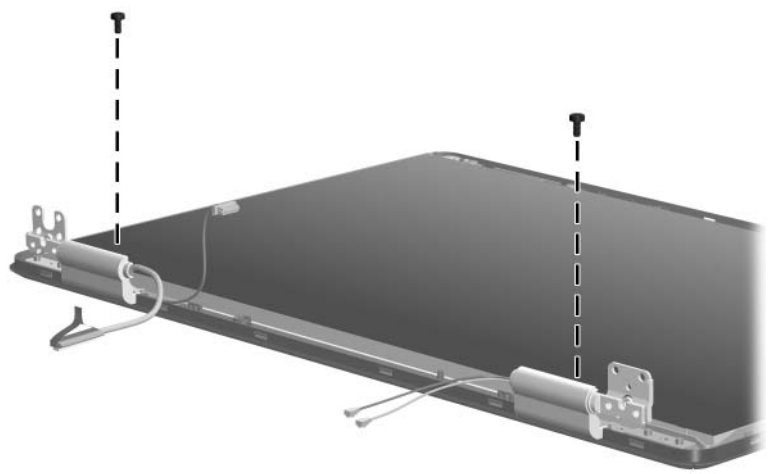

Phillips PM2.5x6.0 Screw Locations

Display Component Recycling



WARNING: The backlight contains mercury. Caution should be exercised when removing and handling the backlight to avoid damaging this component and causing exposure to the mercury.



CAUTION: The procedures in this appendix can result in damage to display components. The only components intended for recycling purposes are the liquid crystal display (LCD) panel and the backlight. Careful handling should be exercised when removing these components.



Materials Disposal

This HP product contains mercury in the display assembly backlight and may require special handling at end-of-life.

Disposal of mercury may be regulated because of environmental considerations. For disposal or recycling information, contact your local authorities or visit the Electronic Industries Alliance (EIA) at <http://www.eiae.org>.

This appendix provides disassembly instructions for the display assembly. The display assembly must be disassembled to gain access to the backlight ❶ and the LCD panel ❷.



Disassembly procedures differ from one display assembly to another. The procedures provided in this appendix are general disassembly instructions. Specific details, such as screw sizes, quantities, and locations, and component shapes and sizes, can vary from one computer model to another.

Refer to [Section 5.11, “Display Assembly,”](#) for display assembly disassembly steps.

Perform the following steps to disassemble the display assembly:

1. Remove all screw covers **1** and screws **2** that secure the display bezel to the display assembly.

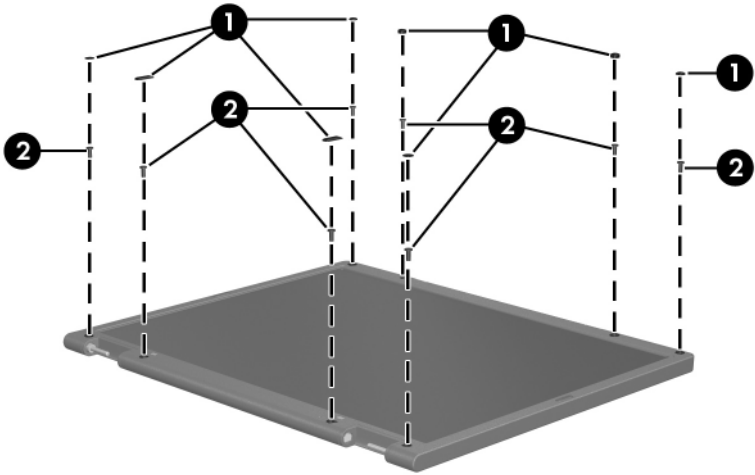

Removing the Display Bezel Screw Covers and Screws

-
2. Lift up and out on the left and right inside edges ❶ and the top and bottom inside edges ❷ of the display bezel until the bezel disengages from the display assembly.
3. Remove the display bezel ❸.

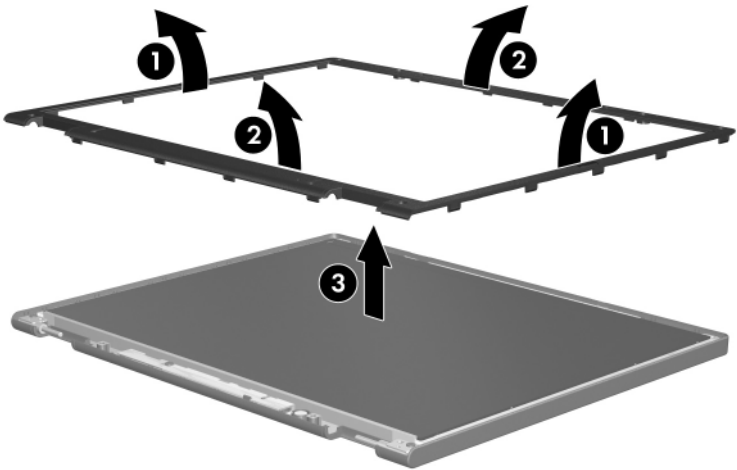

Removing the Display Bezel

4. Disconnect all LCD panel cables ❶ from the display inverter board and remove the inverter board ❷.

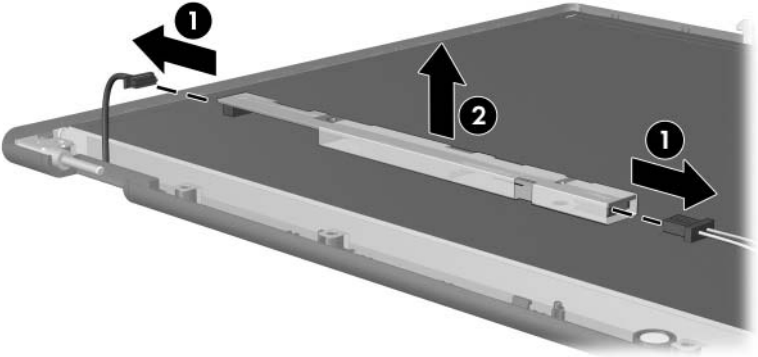

Removing the Display Inverter Board

5. Remove all screws ❶ that secure the LCD panel to the display enclosure.
6. Remove the LCD panel ❷ from the display enclosure.

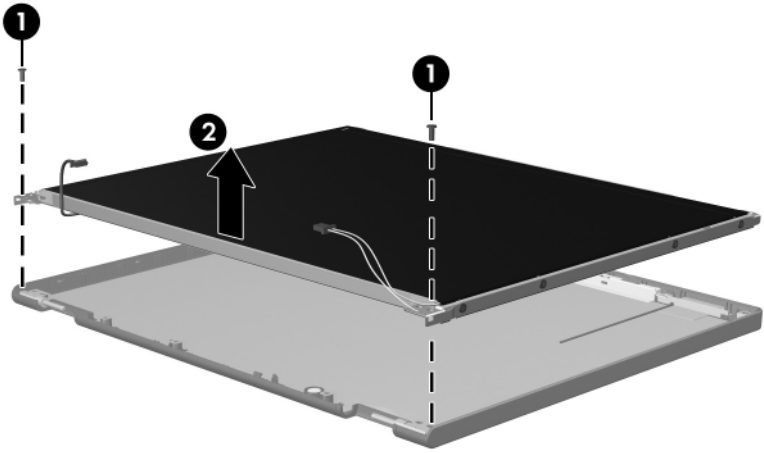

Removing the LCD Panel

7. Turn the LCD panel upside down.
8. Remove all screws that secure the LCD panel frame to the LCD panel.

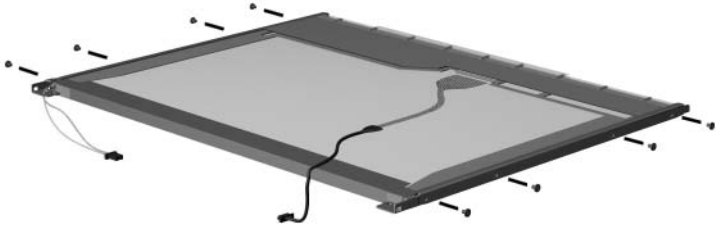

Removing the LCD Panel Frame Screws

9. Use a sharp-edged tool to cut the tape ❶ that secures the side of the LCD panel to the LCD panel frame.
10. Remove the LCD panel frame ❷ from the display panel.

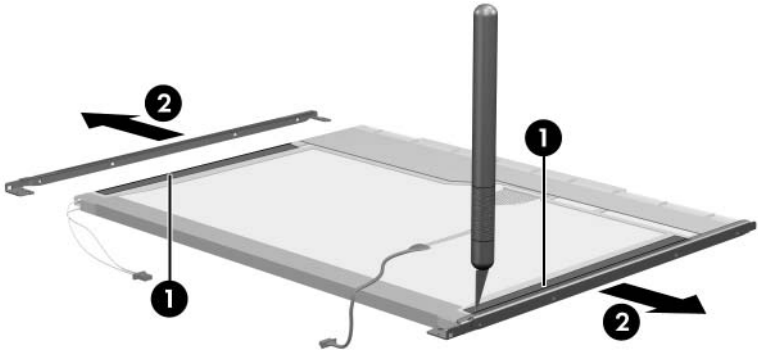

Removing the LCD Panel Frame

11. Remove the screws ❶ that secure the backlight cover to the LCD panel.
12. Lift the top edge of the backlight cover ❷ and swing it forward.
13. Remove the backlight cover.

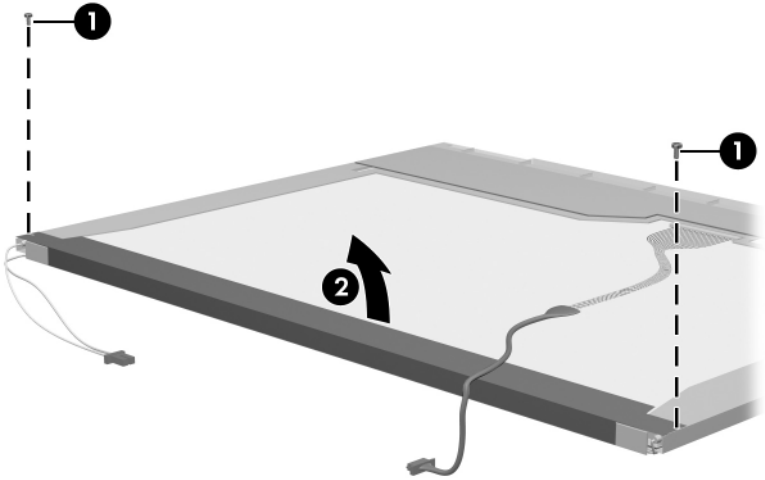

Removing the Backlight Cover

14. Turn the LCD panel right-side up.
15. Remove the backlight cables **1** from the clip **2** in the LCD panel.

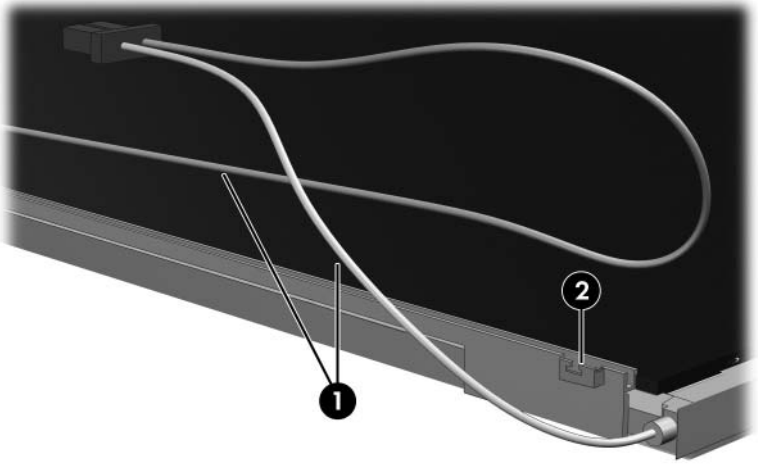

Releasing the Backlight Cables

16. Turn the LCD panel upside down.
17. Remove the backlight frame from the LCD panel.

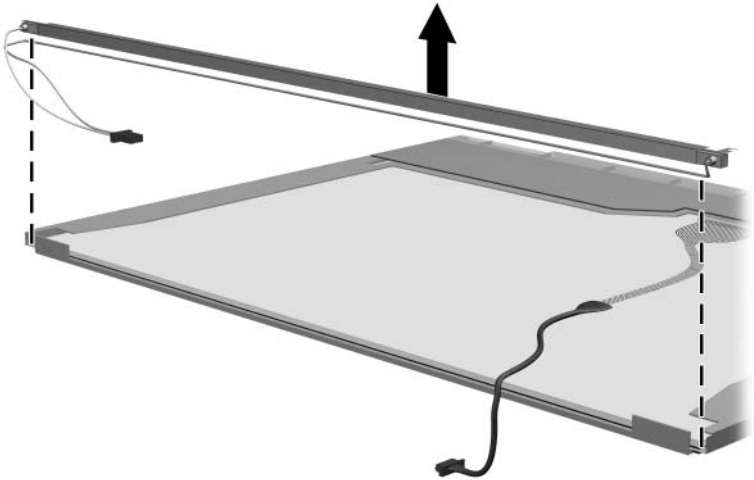

Removing the Backlight Frame



WARNING: The backlight contains mercury. Caution should be exercised when removing and handling the backlight to avoid damaging this component and causing exposure to the mercury.

18. Slide the backlight out of the backlight frame.

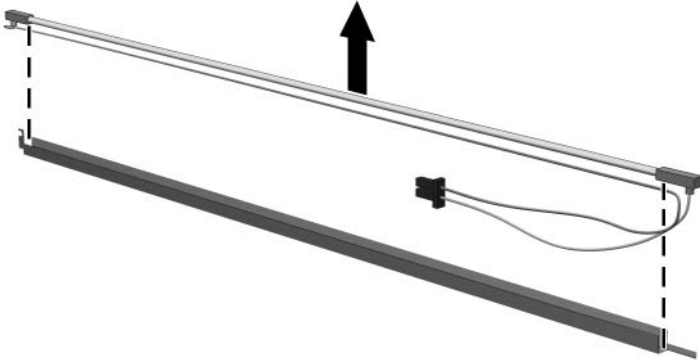

Removing the Backlight

19. Disconnect the display cable ❶ from the LCD panel.
20. Remove the screws ❷ that secure the LCD panel to the LCD rear panel.
21. Release the LCD panel ❸ from the LCD rear panel.
22. Release the tape ❹ that secures the LCD panel to the LCD rear panel.

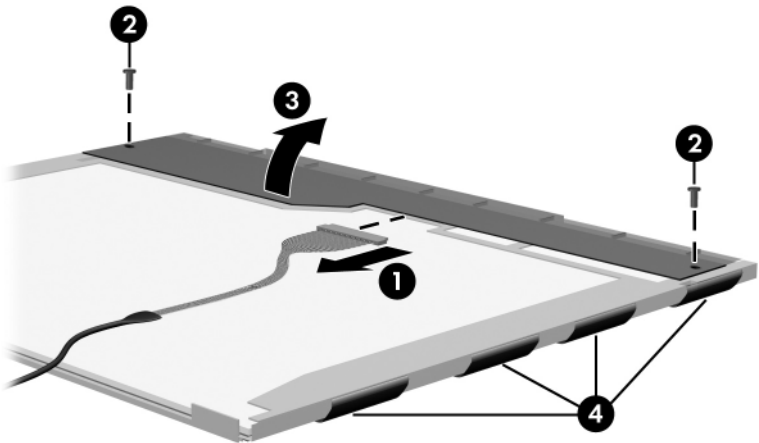

Releasing the LCD Panel

23. Remove the LCD panel.

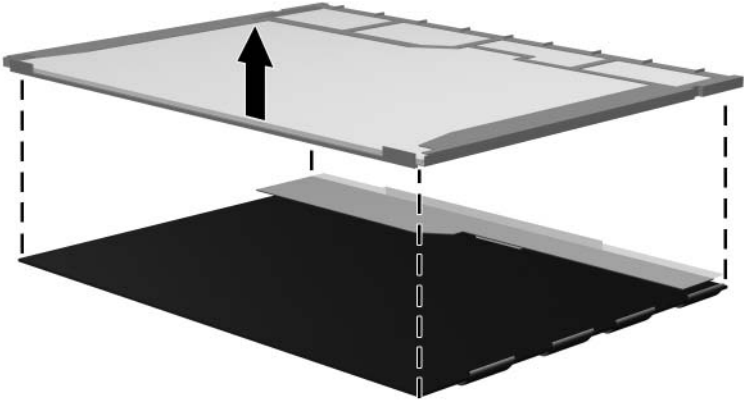

Removing the LCD Panel

24. Recycle the backlight and LCD panel.

Index

1394 port 1–9

A

AC adapter, spare part number
3–17, 3–20

arrow keys 1–13

audio troubleshooting 2–23

audio-in (microphone) jack
location 1–7

pin assignments A–6

audio-out (headphone) jack
location 1–7

pin assignments A–6

B

base enclosure

removal 5–37

spare part number 3–5,
3–23, 5–37

battery light 1–7

battery pack

location 1–18

removal 5–5

spare part numbers 3–5,
3–20

specifications 6–5

battery pack release latch 1–18

Bluetooth module

removal 5–42

spare part number 3–5,
3–24, 5–42

bottom components 1–18

C

cables, service considerations
4–2

caps lock key 1–13

caps lock light 1–14

CMOS clearing 1–4

components

bottom 1–18

front 1–6

keyboard 1–12

left-side 1–10

rear 1–10

right-side 1–8

top 1–14, 1–16

computer feet

illustrated 3–16

locations 5–10

Computer Setup

Advanced Menu 2–6

defaults 2–2

File Menu 2–3

overview 2–1

- Security Menu 2–4
- Tools Menu 2–5
- computer specifications 6–1
- connector pin assignments
 - external monitor A–4
 - headphone A–6
 - microphone A–6
 - monitor A–4
 - RJ-11 (modem) A–5
 - RJ-45 (network) A–2
 - S-Video-out A–3
 - Universal Serial Bus (USB) A–1
- connectors, service
 - considerations 4–2
- D**
- design overview 1–20
- disassembly sequence chart 5–3
- diskette drive, OS loading problems 2–21
- display assembly
 - removal 5–26
 - spare part numbers 3–3, 3–22, 5–26
 - specifications 6–3
- display bezel
 - removal 5–30
 - spare part number 3–22, 5–30
- display cable, spare part number 3–22
- display enclosure, spare part number 3–22, 5–30
- display hinge
 - removal 5–35
 - spare part number 3–22
- display hinge cover
 - removal 5–33
 - spare part number 3–22, 5–33
- Display Hinge Kit, spare part number 5–31, 5–35
- display inverter
 - removal 5–32
 - spare part number 3–22, 5–32
- display panel
 - removal 5–34
 - spare part numbers 3–22, 5–34
- display release button 1–7
- display release hooks, removal 5–31
- Display Screw Kit, spare part number 3–24
- display switch 1–14
- docking device,
 - troubleshooting 2–16
- drive light 1–7
- drives, preventing damage 4–3
- DVD/CD-RW Combo Drive
 - OS loading problems 2–22
 - precautions 4–3
 - spare part number 3–11, 3–15, 3–23, 5–17
 - specifications 6–6

- DVD±RW/R and CD-RW
 - Double-Layer Combo Drive
 - OS loading problems 2–22
 - precautions 4–3
 - spare part number 3–11, 3–15, 3–20, 3–23, 3–24, 5–17
 - specifications 6–8
- E**
 - electrostatic discharge 4–4, 4–8
 - exhaust vents 1–11, 1–19
 - expansion port 2 1–11
 - ExpressCard assembly
 - spare part number 3–5, 3–22
 - ExpressCard slot 1–11
 - ExpressCard slot bezel, illustrated 3–16
 - external monitor port
 - location 1–11
 - pin assignments A–4
- F**
 - f1** to **f12** keys 1–13
 - fan/heat sink assembly
 - removal 5–48
 - spare part number 3–3, 3–24, 5–48
 - features 1–2
 - feet
 - locations 5–10
 - flowcharts, troubleshooting
 - no audio 2–23, 2–24
 - no network/modem connection 2–28
 - no OS loading 2–17
 - no OS loading from diskette drive 2–21
 - no OS loading from hard drive 2–18, 2–19, 2–20
 - no OS loading from optical drive 2–22
 - no power 2–10, 2–12, 2–13
 - no video 2–14, 2–15
 - nonfunctioning device 2–25
 - nonfunctioning docking device 2–16
 - nonfunctioning keyboard 2–26
 - nonfunctioning pointing device 2–27
- fn** key 1–13
- front components 1–6
- G**
 - grounding equipment and methods 4–7
- H**
 - hard drive
 - OS loading problems 2–18
 - precautions 4–3
 - removal 5–6
 - spare part numbers 3–7, 3–15, 3–23, 5–6
 - specifications 6–4
 - hard drive bay 1–19
 - hard drive cover
 - illustrated 3–16
 - removal 5–7

- headphone jack
 - location 1–7
 - pin assignments A–6
- headset, spare part number 3–17, 3–19
- HP backpack, spare part number 3–17, 3–20
- HP Mobile Remote Control, spare part number 3–20
- HP xc2000 Notebook
 - All-in-One Media Cable, spare part number 3–17, 3–20

I

- I/O address specifications 6–13
- interrupt specifications 6–11

K

- keyboard
 - removal 5–23
 - spare part numbers 3–3, 3–19, 5–23
 - troubleshooting 2–26
- keyboard components 1–12
- keypad keys 1–13

L

- label area 1–19
- LED board
 - removal 5–58
 - spare part number 3–3, 3–24, 5–58
- left-side components 1–10
- Logo Kit, spare part number 3–17, 3–20

M

- mass storage devices, spare part numbers 3–14
- memory module
 - removal 5–10
 - spare part numbers 3–11, 3–23, 5–10
- memory module compartment cover
 - illustrated 3–16
 - removal 5–11
- Memory Reader 1–9
- Memory Reader light 1–9
- microphone jack
 - location 1–7
 - pin assignments A–6
- Mini Card compartment 1–19
- Mini Card compartment cover
 - illustrated 3–16
 - removal 5–15
- Mini Card module
 - removal 5–13
 - spare part numbers 3–7, 3–9, 3–20, 3–21, 3–22, 5–13
- modem jack
 - location 1–11
 - pin assignments A–5
- modem, troubleshooting 2–28
- monitor port
 - location 1–11
 - pin assignments A–4
- mouse, spare part number 3–17, 3–19

N

- network jack
 - location 1–11
 - pin assignments A–2
- network, troubleshooting 2–28
- nonfunctioning device,
 - troubleshooting 2–16, 2–25

- num lock** key 1–13
- num lock light 1–15

O

- optical drive
 - location 1–9, 1–18
 - OS loading problems 2–22
 - precautions 4–3
 - removal 5–17
 - spare part numbers 3–11, 3–15, 5–17

P

- packing precautions 4–5
- password clearing 1–4
- plastic parts 4–2
- Plastics Kit
 - contents 3–16
 - spare part number 3–5, 3–16, 3–23
- pointing device,
 - troubleshooting 2–27
- power button 1–15
- power connector 1–11
- power cord
 - set requirements B–2
 - spare part numbers 3–18, 3–19, 3–20
- power light 1–7, 1–15

- power management features 1–5
- power, troubleshooting 2–10
- processor
 - removal 5–50
 - spare part numbers 3–5, 3–22, 5–50

R

- rear components 1–10
 - removal
 - preliminaries 4–1
 - procedures 5–1
 - replacement
 - preliminaries 4–1
 - procedures 5–1
 - right-side components 1–8
 - RJ-11 (modem) jack
 - location 1–11
 - pin assignments A–5
 - RJ-45 (network) jack
 - location 1–11
 - pin assignments A–2
 - RTC battery
 - removal 5–46
 - spare part number 3–5, 3–23, 5–46
 - Rubber Feet Kit, spare part number 3–5, 3–24
- S**
- Screw Kit, spare part number 3–17, 3–23
 - screw listing C–1
 - SD Memory Card, spare part number 3–11, 3–20

- security cable slot 1–11
- serial number 3–1, 5–2
- service considerations 4–1
- speaker assembly
 - removal 5–44
 - spare part number 3–5, 3–20, 5–44
- speakers 1–7
- specifications
 - battery pack 6–5
 - computer 6–1
 - display 6–3
 - DVD/CD-RW Combo Drive 6–6
 - DVD±RW/R and CD-RW Double-Layer Combo Drive 6–8
 - hard drive 6–4
 - I/O addresses 6–13
 - interrupts 6–11
 - system DMA 6–10
- static shielding materials 4–8
- S-Video-out jack
 - location 1–9
 - pin assignments A–3
- switch cover
 - removal 5–20
 - spare part numbers 3–3, 3–20, 5–20
- system board
 - removal 5–52
 - spare part number 3–5, 3–22, 5–52
- system DMA 6–10

T

- tools required 4–1
- top components 1–14, 1–16
- top cover, spare part number 3–23
- top cover, spare part numbers 3–3
- TouchPad 1–17
- TouchPad buttons 1–17
- TouchPad horizontal scrolling region 1–17
- TouchPad light 1–17
- TouchPad on/off button 1–17
- TouchPad vertical scroll region 1–17
- transporting precautions 4–5
- troubleshooting
 - audio 2–23
 - Computer Setup 2–2
 - docking device 2–16
 - flowcharts 2–7
 - keyboard 2–26
 - modem 2–28
 - network 2–28
 - nonfunctioning device 2–16, 2–25
 - OS loading 2–17
 - overview 2–1
 - pointing device 2–27
 - power 2–10
 - video 2–14

U

- Universal Serial Bus (USB)
 - connector
 - location 1–9, 1–11
 - pin assignments A–1
 - unknown password 1–4
- USB camera cable, spare part
 - number 3–22
- USB digital drive, spare part
 - number 3–15, 3–19
- USB travel mouse, spare part
 - number 3–17, 3–19
- USB/S-Video board
 - removal 5–40
 - spare part number 3–5,
3–24, 5–40

V

- video troubleshooting 2–14
- volume buttons 1–15

W

- Windows applications key
 - 1–13
- Windows logo key 1–13
- wireless antenna cable
 - removal 5–36
- wireless button 1–15
- wireless button light 1–7
- wireless light 1–15
- workstation precautions 4–6