

# ZANUSSI

## BUILT-IN OVEN

### ZBF 669

INSTRUCTION BOOKLET

Please read this instruction booklet before using the appliance

GB

# Important Safety Information



You **MUST** read these warnings carefully before installing or using the oven. If you need assistance, contact our Customer Care Department on 08705 727727

## Installation

- This oven must be installed by qualified personnel to the relevant British Standards.
- This oven is heavy. Take care when moving it.
- Remove all packaging, both inside and outside the oven, before using the oven.
- Do not attempt to modify the oven in any way.

## Child Safety

- This oven is designed to be operated by adults. Do not allow children to play near or with the oven.
- The oven gets hot when it is in use. Children should be kept away until it has cooled.

## During Use

- This oven is intended for domestic cooking only. It is not designed for commercial or industrial purposes.
- Never line any part of the oven with aluminium foil.
- Do not allow heatproof cooking material, e.g. roasting bags, to come into contact with oven elements.
- Never place plastic or any other material which may melt in or on the oven.
- Do not place sealed cans or aerosols inside the oven. They may explode if they are heated.
- Do not hang towels, dishcloths or clothes from the oven or its handle.
- Do not use this oven if it is in contact with water and never operate it with wet hands.
- Take great care when heating fats and oils as they will ignite if they become too hot.
- Always use oven gloves to remove and replace food in the oven.
- Ensure that all control knobs are in the OFF position when not in use.
- Do not leave cookware containing foodstuffs, e.g. fat or oil in or on the oven in case it is inadvertently switched ON.
- When using other electrical appliances, ensure the cable does not come into contact with the hot surfaces of the oven.

## Maintenance and Cleaning

- Only clean this oven in accordance with the instructions.
- The oven should be kept clean at all times. A build-up of fats or other foodstuffs could result in a fire, especially in the grill pan.
- Always allow the oven to cool down and switch off the electrical supply before carrying out any cleaning or maintenance work.

## Service

- This oven should only be repaired or serviced by an authorised Service Engineer and only genuine approved spare parts should be used.

## Environmental Information

- After installation, please dispose of the packaging with due regard to safety and the environment.
- When disposing of an old appliance, make it unusable, by cutting off the cable. Remove any door catches, to prevent small children being trapped inside.

**Keep this instruction book for future reference and ensure it is passed on to any new owner.**

# Contents

## For the User

Important Safety Information	2
Description of the Oven	4
Controls	5
Electronic programmer	6
Before the First Use	8
Using the Oven	8
Hints and Tips	9
Using the Conventional Oven	10
The Fan Oven	12
Grilling	14
Defrosting	15
Cleaning the Oven	16
Replacing the Oven Light	17
Cleaning the hinged grill	17
Service and Spare Parts	18
Something not working	18
Customer Care	19
Guarantee Conditions	19

## For the Installer

Installation	20
Electrical Connection	20
Building In	21

### Oven Door Protection Device

(stainless steel models only)

All our appliances comply with the European safety standards. Nevertheless, in order to ensure the highest safety level, and avoid little children to be exposed to the heat when the appliance is operated, it is possible to fit a special protection device to the oven door. This device can be purchased in our Service Force Centres, specifying the relevant code ( 357828401/4) and the Product No. shown on the rating plate.

## Guide to use the instructions

The following symbols will be found in the text to guide you throughout the Instructions:

 Safety Instructions

 Step by step instructions for an operation

 Hints and Tips

 Environmental information

 This appliance complies with the following **E.E.C. Directives:**  
\*73/23 - 90/683 (Low Voltage Directive);  
\*93/68 (General Directives);  
\*89/336 (Electromagnetical Compatibility Directive) and subsequent modifications.

# Description of the Oven

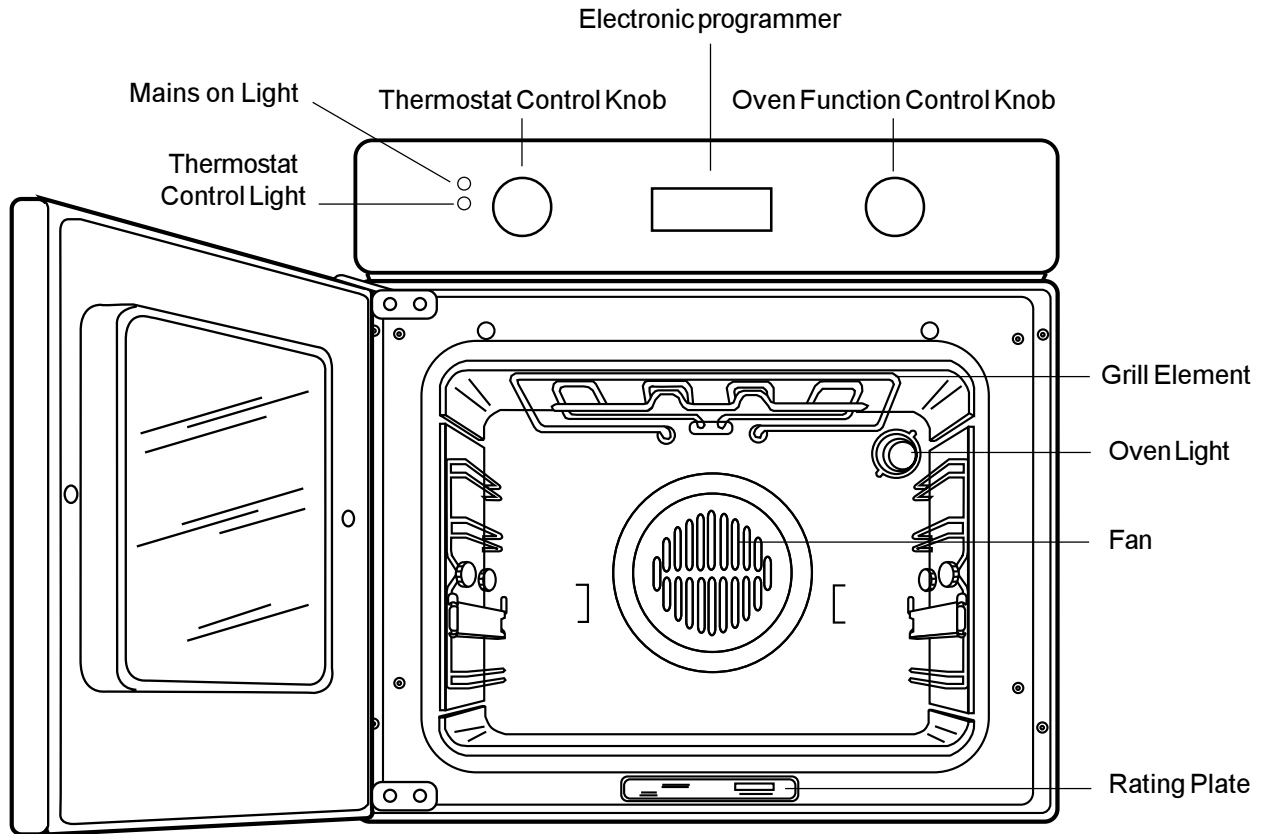



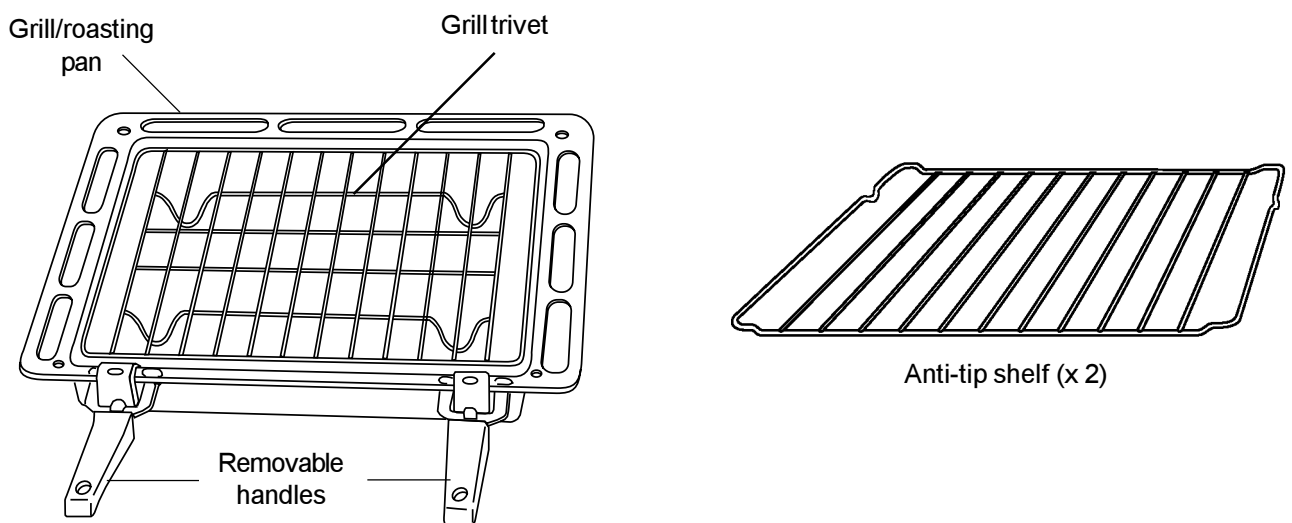



## Oven accessories



# Controls

## Oven Function Control Knob

-  Conventional cooking - The heat comes from both the top and bottom element, ensuring even heating inside the oven
-  Bottom heating element - The heat comes from the bottom of the oven only
-  Fan cooking - This allows you to roast or roast and bake simultaneously using any shelf, without flavour transference
-  Inner grill element only - Can be used for grilling small quantities
-  Full Grill - The full grill element will be on
-  Defrost Setting - This setting is intended to assist in thawing of frozen food.

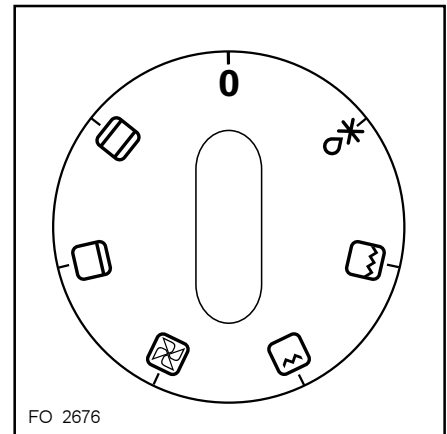

## Mains on Light

The mains on light will come on when the oven function control knob is set.

## Thermostat Control Knob (°C)

Turn the thermostat control knob clockwise to select temperatures between 50°C and 250°C (MAX).

## Thermostat Control Light

The thermostat control light will come on when the thermostat control knob is turned. The light will remain on until the correct temperature is reached. It will then cycle on and off to show the temperature is being maintained.

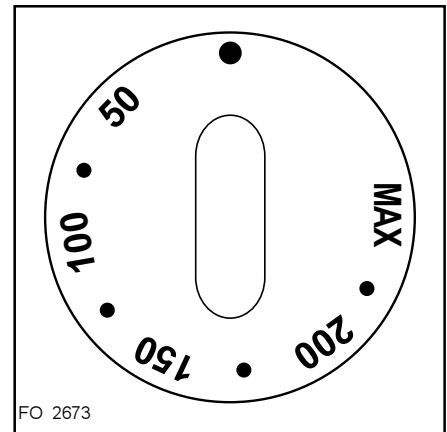

## The Safety Thermostat

This oven is provided with a safety thermostat. In case of malfunctioning of the main thermostat, and consequent over-heating, the safety device will stop the power supply to the appliance. If this happens, call your local Service Force Centre. Under no circumstances should you attempt to repair the appliance yourself.

# Electronic programmer

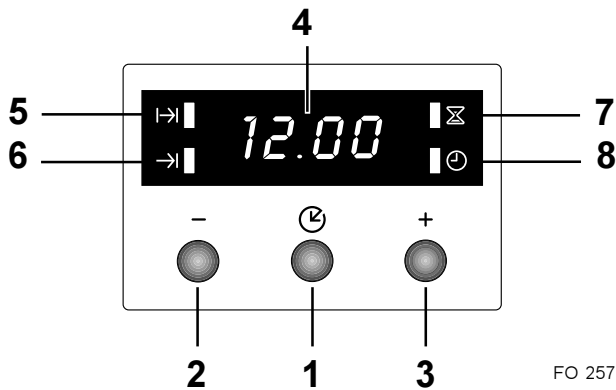

FO 2571

1. Push button for selecting a function
2. Decreasing control button “-”
3. Increasing control button “+”
4. Display
5. “Cooking Duration” pilot lamp
6. “End of cooking” pilot lamp
7. “Minute minder” pilot lamp
8. “Time of day” pilot lamp

**i** The oven will work only if the time of day has been set. However, the oven can also be operated without any programme.

## Setting the time of day

When the power supply is switched on, or after a power failure, the “Time of day” pilot lamp will flash on the display.

**To set the correct time of day:**

1. Press button “+” or “-”.
2. After the setting is carried out, wait for 5 seconds: the “Time of day” pilot lamp will go out and the display will show the set time. The appliance is ready for use.

**To reset the correct time of day:**

1. Press button repeatedly to select the “Time of day” function. The relevant pilot lamp will start flashing. Then proceed as described above. The time of day can only be reset if no automatic function (cook duration or end of cooking ) has been set.

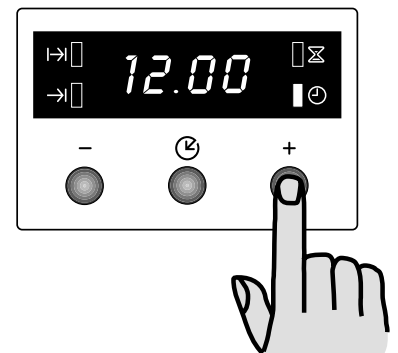

## “Cooking Duration” function

This function allows the oven to automatically switch off at the end of a programmed cooking duration time. Place food in the oven, select a cooking function and adjust the cooking temperature. Press button repeatedly to select the “Cooking Duration” function. The relevant pilot lamp will start flashing. Then, proceed as follows:

**To set the duration time:**

1. Press button “+” or “-”.
2. After the setting is carried out, wait for 5 seconds: the “Cooking Duration” pilot lamp will come on and the display will revert to the time of day.
3. When cooking time is over, the oven will be switched off automatically and an acoustic alarm will be heard, while the pilot lamp will start flashing. Turn the oven function and the thermostat control knob to zero.

To switch off the acoustic alarm, press any button.

**NOTE:** turning the acoustic alarm off will reset the oven to manual, and if the oven function and the thermostat knobs are not set to zero the oven will start to heat again.

**To cancel the duration time:**

1. Press button repeatedly to select the “Cooking Duration” function. The relevant pilot lamp will flash and the display will show the remaining cooking time.
2. Press button “-” until the display shows “0:00”. After 5 seconds the pilot lamp will go out and the display will revert to the time of day.

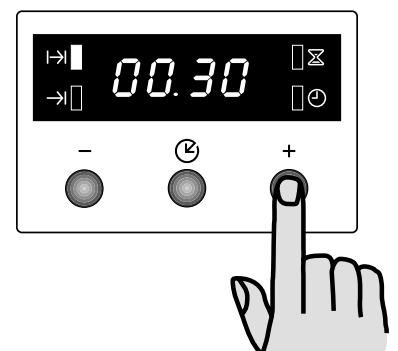
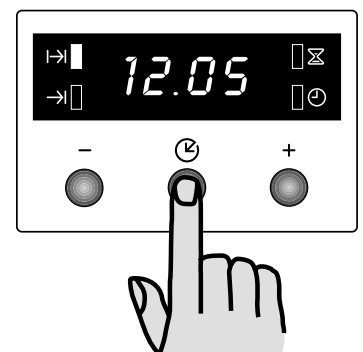

## “End of cooking” function →|

Thanks to this function, you can set the oven to switch off automatically when a programmed end of cooking time is over. Place food in the oven, select a cooking function and adjust the cooking temperature. Press button  repeatedly to select the “End of cooking” function. The relevant pilot lamp →| will start flashing. Then, proceed as follows:

### To set the End of cooking time:

1. Press button “+” or “-”.
2. After the setting is carried out, wait for 5 seconds: the “End of cooking” pilot lamp →| will come on and the display will revert to the time of day.
3. When cooking time is over, the oven will be switched off automatically and an acoustic alarm will be heard, while the pilot lamp will start flashing. Turn the oven function and the thermostat control knob to zero.

To switch off the acoustic alarm, press any button. **NOTE:** turning the acoustic alarm off will reset the oven to manual, and if the oven function and the thermostat knobs are not set to zero the oven will start to heat again.

### To cancel the End of cooking time:

1. Press button  repeatedly to select the “End of cooking” function. The relevant pilot lamp →| will flash and the display will show the programmed End of cooking time.
2. Press button “-” until the display shows the current time of day. The programmer will beep and the pilot lamp will go out.

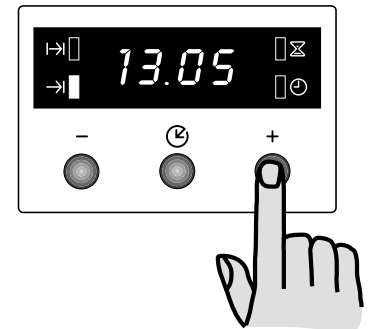
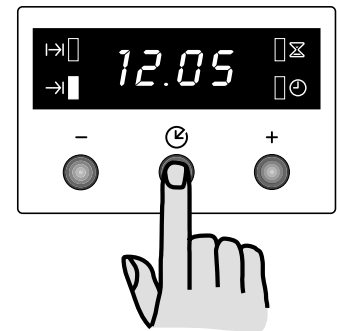

## “Cooking duration” |→| and “End of cooking time” →| combined

The functions “Cooking duration” and “End of cooking time” can be used simultaneously to set the oven to switch on and off automatically at a later time.

1. With the “Cooking duration” function |→| (carry out the cooking duration setting as described in the relevant chapter) set the duration time. Then, press button : the display will show the programmed setting.
2. With the “End of cooking time” function →| (carry out the End of cooking setting as described in the relevant chapter) set the end of cooking time. The relevant pilot lamps will come on and the display will show the time of day. The oven will switch on and off according to the set programmes.

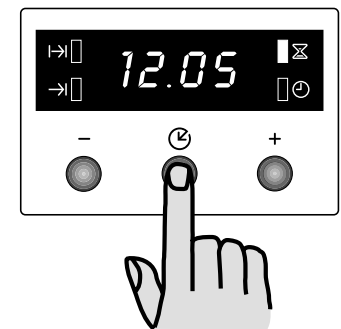

## “Minute minder” function ⌘

The minute minder alarm will sound at the end of a timed period, but THE OVEN WILL REMAIN ON, if it is in use.

### To set the minute minder:

1. Press button  repeatedly to select the “Minute minder” function. The relevant pilot lamp ⌘ will start flashing.
2. Then, press button “+” or “-” (maximum: 2 hours, 30 minutes).
3. After the setting is carried out, wait for 5 seconds: the “Minute minder” pilot lamp ⌘ will come on.
4. At the end of the timed period, the pilot lamp will start flashing and an acoustic alarm will be heard. To switch off the acoustic alarm, press any button.

### To cancel the minute minder:

1. Press button  repeatedly to select the “Minute minder” function. The relevant pilot lamp ⌘ will flash and the display will show the remaining time.
2. Press button “-” until the display shows “0:00”. After 5 seconds the pilot lamp will go out and the display will revert to the time of day.

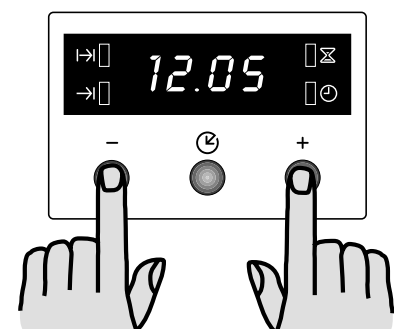
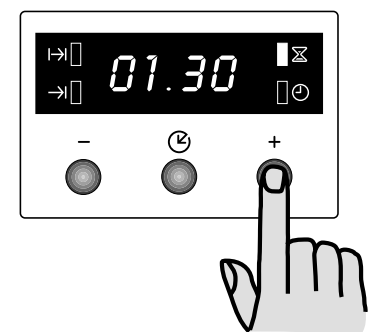

## How to switch off the display

1. Press two or three programmer push buttons simultaneously and keep them pressed for about 5 seconds. The display will switch off.
2. To switch on the display, press any button.

**The display can be switched off only if no other functions have been set.**



# Before the First Use

 Remove **all packaging**, both inside and outside the oven, before using the oven.

Before first use, the oven should be heated without food. During this time, an unpleasant odour may be emitted. This is quite normal.

 **The oven will work only if the time of day has been set.**

1. Set the time of day with the electronic programmer (see chapter "Electronic Programmer").
2. Switch the oven function control knob to conventional cooking .
3. Set the thermostat control knob to MAX.
4. Open a window for ventilation.
5. Allow the oven to run empty for approximately 45 minutes.

This procedure should be repeated with the grill  function and the fan cooking  function for approximately 5-10 minutes.

## Using the Oven

 **Always cook with the oven door closed.** Stand clear when opening the oven door.

 The oven has four shelf levels, counted from the bottom, as shown in the diagram. Your oven is supplied with two anti-tip shelves.

It is important that these shelves are correctly positioned as shown in the diagram.

Shelf level 2 is fitted with telescopic shelf supports.

**Do not place cookware directly on the oven base.**

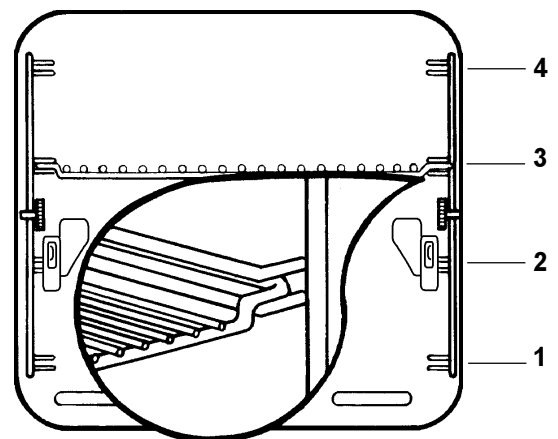

### The cooling fan

The cooling fan operates during cooking. Air is expelled through vents between the oven door and the control panel, as shown in the diagram.

The cooling fan may run on after the oven is switched off to keep the controls cool. This is quite normal.

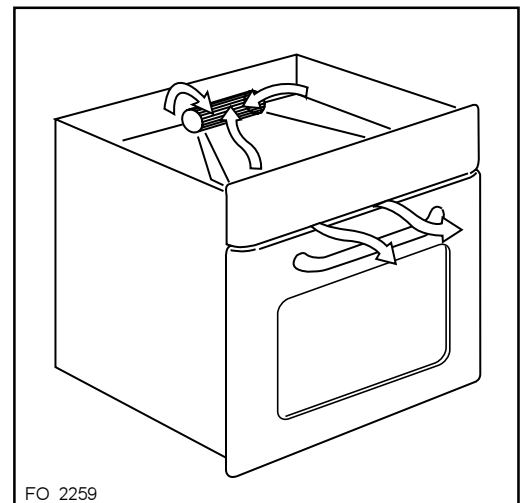

FO 2259



## Telescopic shelf supports

 Shelf level 2 is fitted with telescopic shelf supports.

1. Pull the right and left hand telescopic shelf supports completely out, as shown in the diagram.
2. Place the shelf or the grill pan on the telescopic shelf supports, as shown in the diagram, then gently push them all inside the oven.



*Do not attempt to close the oven door if the telescopic shelf supports are not completely inside the oven. This could damage the door enamel and glass.*

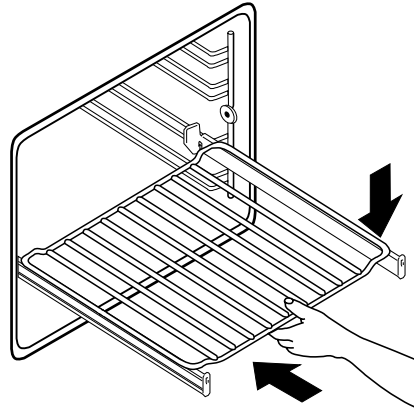
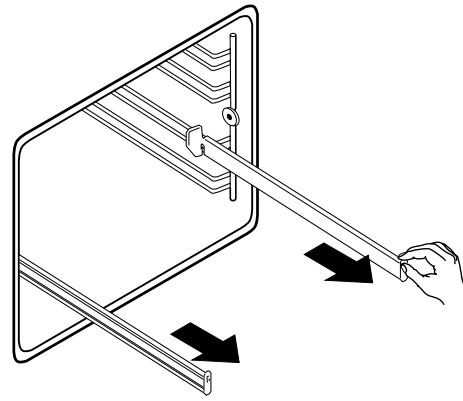

## Hints and Tips

### Condensation and steam

When food is heated it produces steam in the same way as a boiling kettle. The oven vents allow some of this steam to escape. However, **always stand back from the oven when opening the oven door** to allow any build up of steam or heat to release.

If the steam comes into contact with a cool surface on the outside of the oven, e.g. a trim, it will condense and produce water droplets. This is quite normal and is not a fault with the oven.

To prevent discolouration, regularly wipe away condensation and also soilage from surfaces.

### Cookware

- Use any oven proof cookware which will withstand temperatures of 250°C.
- Baking trays, oven dishes, etc. should not be placed directly against the grid covering the fan at the back of the oven, or placed on the oven base.
- Do not use baking trays larger than 30 cm x 35 cm (12 in x 14 in) as they will restrict the circulation of heat and may affect performance.

### The effects of dishes on cooking results

Dishes and tins vary in their thickness, conductivity, colour, etc. which affects the way they transmit heat to the food inside them.

- A** Aluminium, earthenware, oven glassware and bright shiny utensils reduce cooking and base browning.
- B** Enamelled cast iron, anodized aluminium, aluminium with non-stick interior and coloured exterior and dark, heavy utensils increase cooking and base browning.

# Using the Conventional Oven

When using this setting, heat comes from both the top and bottom elements. This allows you to cook on a single level and is particularly suitable for dishes which require extra base browning such as pizzas, quiches and flans. Gratins, lasagnes and hotpots which require extra top browning also cook well in the conventional oven. This form of cooking gives you the opportunity to cook without the fan in operation.

## How to Use the Conventional Oven

1. Turn the oven function control knob to the required cooking function (.
2. Turn the thermostat control to the required temperature.

### THINGS TO NOTE

- The oven light will come on when the oven function control knob is set.
- The thermostat control light will remain on until the correct temperature is reached. It will then cycle on and off to show that temperature is being maintained.

## Bottom oven element only

This function is particularly useful when blind-baking pastry or cooking pizza. It may also be used to finish off quiches or flans to ensure the base pastry is cooked through.

## The Cooling Fan

- The cooling fan will operate continually during cooking. It may run on after the oven is switched off to keep the controls cool. This is quite normal.

### NOTE

The action of the cooling fan will depend on how long the oven has been used and at what temperature. It may not switch in at all at lower temperature settings nor run on where the oven has only been used for a short time.

## Hints and Tips

- The middle shelf position allows for the best heat distribution. To increase base browning simply lower the shelf position. To increase top browning, raise the shelf position.
- The material and finish of the baking trays and dishes used will affect base browning. Enamelware, dark, heavy or non-stick utensils increase base browning, while oven glassware, shiny aluminium or polished steel trays reflect the heat away and give less base browning.
- Always place dishes centrally on the shelf to ensure even browning.
- Stand dishes on suitably sized baking trays to prevent spillage onto the base of the oven and make cleaning easier.
- **Do not** place dishes, tins or baking trays directly on the oven base as it becomes very hot and damage will occur.
- For faster preheating use the fan oven function to preheat the oven until the oven indicator neon goes out, then switch the selector to the conventional oven setting.
- Single level cooking gives best results. If you require more than one level cooking use the fan oven function.

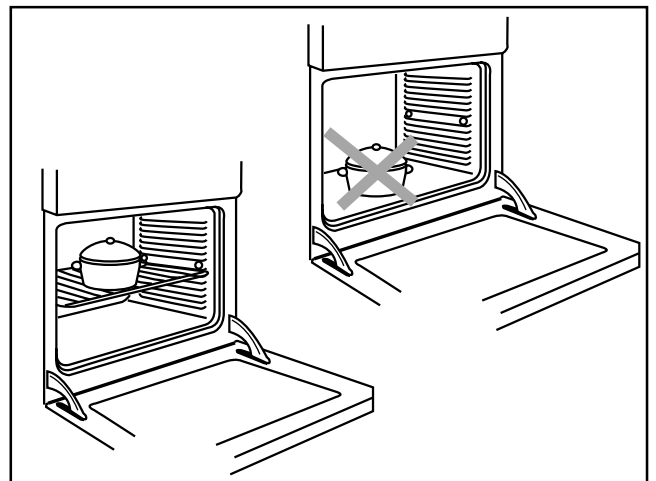

## Cooking Chart - Conventional Oven

Food	Temperature (°C)	Shelf Positions	Cooking Time (mins)
Biscuits	170-200	2	25-30
Bread, buns, yeast, doughs	200-230	2	35-45
Casseroles	140-170	1 - 2	90-180
Cakes - small, Queen Victoria sponge	170-190	1 - 2	18-25
Cakes - madeira, rich fruit	130-180	2	90-150
Choux pastry, eclairs	200-230	2	30-35
Fish	200-230	2	20-40
Fruit pies, plate tarts, crumbles	180-210	2	50-65
Meringues	90-100	2	90-150
Milk puddings	140-160	2	90-150
Pate, terrine (in baine-marie)	160-180	1 - 2	60-90
Pizzas	200-230	1 - 2	25-30
Puff pastry, sausage rolls, vol-au-vents	230-250	2	15-25
Quiches, flans	170-200	1 - 2	50-60
Scones	230-250	2	8-12
Souffle	200-230	2	35-45
Stuffed vegetables	230-250	2	35-45
Roast meat & poultry	180-200	2	see meat + poultry roasting chart
Yorkshire pudding	200-230	2	40-50
Keep food warm, heat dishes	90-100	2	

**NOTE:** Shelf positions are counted from bottom of the oven. These charts are intended as a guide only and should be adjusted according to taste.

## Meat and Poultry Roasting Chart (Conventional Oven + Fan Oven)

Meat	Cooking Time
Beef	20-35 mins per 1/2kg (lb) + <b>20-35 mins</b>
Beef, boned	25-35 mins per 1/2kg (lb) + <b>25-35 mins</b>
Mutton and Lamb	25-35 mins per 1/2kg (lb) + <b>25-35 mins</b>
Pork and Veal	30-40 mins per 1/2kg (lb) + <b>30-40 mins</b>
Ham	30-40 mins per 1/2kg (lb) + <b>30-40 mins</b>
Chicken	15-20 mins per 1/2kg (lb) + <b>20 mins</b>
Turkey and Goose	15-20 mins per 1/2kg (lb) up to 3.5kg (7lb) + <b>15 mins per 1/2kg</b> over 3.5kg (7lb)
Duck	25-35 mins per 1/2kg (lb) + <b>20 mins</b>

When roasting, ensure the meat is cooked thoroughly, use a meat thermometer if preferred to check the centre temperature has reached the required temperature (see table below).

MEAT	TEMPERATURES
Beef	Rare - 60°C Medium - 70°C Well Done - 80°C
Pork	Well Done - 80°C
Lamb	Medium - 70°C Well Done - 80°C

# The Fan Oven

The air inside the oven is heated by the element around the fan situated behind the back panel. The fan circulates hot air to maintain an even temperature inside the oven.

**The advantage of cooking with this function is energy saving through:**

- **Faster Preheating**

As the fan oven quickly reaches temperature, it is not usually necessary to preheat the oven although you may find that you need to allow an extra 5-7 minutes on cooking times. For recipes which require higher temperatures, best results are achieved if the oven is preheated first, e.g. bread, pastries, scones, souffles, etc.

- **Lower Temperatures**

Fan oven cooking generally requires lower temperatures than conventional cooking. Follow the temperatures recommended in the cooking chart. Remember to reduce temperatures by about 20-25°C for your own recipes which use conventional cooking.

- **Even Heating for Baking**

The fan oven has uniform heating on all runner positions. This means that batches of the same food can be cooked in the oven at the same time. However, the top shelf may brown slightly quicker than the lower one. This is quite usual. There is no mixing of flavours between dishes.

## How to use the Fan Oven

1. Turn the oven function control knob to .
2. Turn the thermostat control to the required temperature.

## Things to note

- The oven light will come on when the oven function control knob is set.
- The oven fan will operate continually during cooking.
- The thermostat control light will remain on until the correct temperature is reached. It will then cycle on and off to show the temperature is being maintained.

## The cooling fan

During cooking the cooling fan will operate continually. It may run on after the oven is switched off to keep the controls cool. This is quite normal.

### NOTE

The action of the cooling fan will depend on how long the oven has been used and at what temperature. It may not switch in at all at lower temperature settings nor run on where the oven has only been used for a short time.

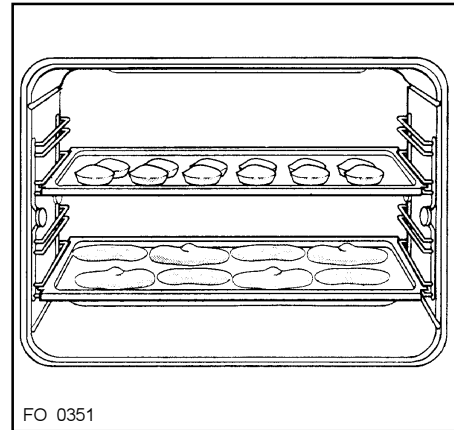

## Hints and Tips

- Runner positions are not critical, but make sure the shelves are evenly spaced.
- When cooking more than one dish in the fan oven, place dishes centrally on the shelves rather than several dishes on one shelf.
- When the oven is full, you may need to allow slightly longer cooking time.
- When the oven is full of the same food, e.g. equal trays of small cakes or equal size victoria sandwich cakes, then they will be cooked in the same time and removed from the oven together. When different sizes of trays or types of food, e.g. biscuits and cakes are cooked, they will not necessarily be ready together.
- The fan oven can be used to heat foods through without thawing first, e.g. fruit tarts, mince pies, sausage rolls, and other small pastry items. Use a temperature of 190-200°C and allow 20-40 minutes (depending on the quantity of food in the oven).
- The use of too high temperatures can cause uneven browning. Check with the recommendations for oven temperatures given in the cooking charts, but be prepared to adjust the temperature, if necessary. Remember to reduce temperatures by about 20-25°C for your own conventional recipes.
- When roasting do use the trivet in the meat tin. Fat and meat juices will drain into the meat tin below and can be used to make gravy. The trivet also prevents splashes of fat from soiling the oven interior.
- The meat tin **should not** be placed on a heated hotplate as this may cause the enamel to crack.

# Cooking Chart - Fan Oven

This chart is intended as a guide only. It may be necessary to increase or decrease the temperature to suit your individual requirements. Only experience will enable you to determine the correct setting for your personal requirements.

Food	Shelf Position	Cooking Temp (°C)	
Biscuits	Shelf positions are not critical but ensure that oven shelves are evenly spaced when more than one is used.	180-190	
Bread		210-220	
Casseroles		130-140	
Cakes: Small and queen		160-170	
Sponges		160-170	
Madeira		140-150	
Rich Fruit		130-140	
Christmas		130-140	
Meringues		90-100	
Fish		170-190	
Fruit Pies and Crumbles		190-200	
Milk Puddings		130-140	
Pastry: Choux		}	190-200
Shortcrust			
Flaky			
Puff			
Plate Tarts	180		
Quiches/Flans	170-180		
Scones	210-220		
Roasting: Meat & Poultry	160-180		

When roasting, ensure the meat is cooked thoroughly, use a meat thermometer if preferred to check the centre temperature has reached the required temperature (see page 10).

# Grilling



**Grilling must be carried out with the oven door closed.**

**The grill pan handles must be removed from the pan during grilling.** Always use oven gloves to remove and replace the grill pan handles.

Ensure that you **support** the grill pan when removing it from the oven.



## How to Use the Grill

1. Turn the oven control function knob on .
2. Turn the thermostat control knob on the required temperature.
3. Adjust the grid and grill pan runner position to allow for different thicknesses of food. Position the food close to the element for faster cooking and further away for more gentle cooking.

Preheat the grill on a full setting for a few minutes before sealing steaks or toasting. Adjust the heat setting and the shelf as necessary, during cooking.

During cooking, the cooling fan and the thermostat control light will operate in the same way as described for the fan oven function.



## Hints and Tips

- Most foods should be placed on the grid in the grill pan to allow maximum circulation of air to lift the food out of the fats and juices. Food such as fish, liver and kidneys may be placed directly on the grill pan, if preferred
- Food should be thoroughly dried before grilling to minimise splashing. Brush lean meats and fish lightly with a little oil or melted butter to keep them moist during cooking.
- Accompaniments such as tomatoes and mushrooms may be placed underneath the grid when grilling meats
- When toasting bread, we suggest that the top runner position is used.
- The food should be turned over during cooking, as required.

**The grill element is controlled by the thermostat. During cooking, the grill cycles on and off to prevent overheating.**



## How to Use the Inner Grill

### Element

The inner grill provides quick direct heat to the central area of the grill pan. By using the inner grill element for cooking small quantities, it can help to save energy.

1. Turn the oven control function knob on .
2. Turn the thermostat control knob on the required temperature.
3. Adjust the grid and grill pan runner position to allow for different thicknesses of food and follow the instructions for grilling.

## Cooking chart

Cooking time depends on the thickness of the meat and not on its weight.

Type of food	Mins per side
Bacon rashers	2 - 5
Chicken joints	15 - 20
Gammon rashers	5 - 8
Lamb chops	6 - 12
Pork chops	10 - 15
Sausages (turning as required)	10 - 12
Steaks (average thickness)	Rare 3 - 6
	Medium 6 - 10
	Well done 8 - 12
Toast	1 - 1½

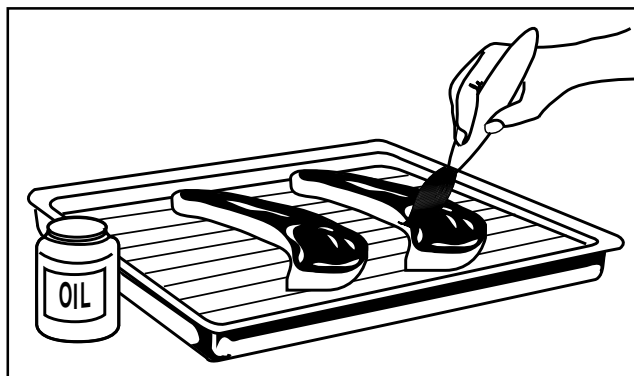

# Defrosting

The oven fan operates without heat and circulates the air, at room temperature, inside the oven. This increases the speed of defrosting. However, please note that the temperature of the kitchen will influence the speed of defrosting.

This function is particularly suitable for delicate food which could be damaged by heat, e.g. cream filled gateaux, iced cakes, pastries, bread and other yeast products.

## How to Use Defrosting

1. Turn the oven function control knob to .
2. Ensure the thermostat control knob is in the OFF position.

## Hints and Tips

- Cover food with a lid, aluminium foil or plastic film to prevent drying out during defrosting.
- ALWAYS COOK THOROUGHLY IMMEDIATELY AFTER THAWING.
- Frozen food should be placed in a single layer when ever possible and turned over half way through the defrosting process.
- Only joints of meat and poultry up to 2 kg. (4 lb.) are suitable for defrosting in this way.

Refer to the following table for approximate defrosting times.

Food	Defrosting time (Mins)	Standing time (Mins)	Notes
Chicken 1000 g.	100-140	20-30	Place the chicken on an inverted saucer on a large plate. Defrost open and turn at half time or defrost covered with foil. Remove giblets as soon as possible.
Meat 1000 g.	100-140	20-30	Defrost open and turn at half time or cover with foil
Meat 500 g.	90-120	20-30	As above
Trout 150 g.	23-35	10-15	Defrost open
Strawberries 300 g.	30-40	10-20	Defrost open
Butter 250 g.	30-40	10-15	Defrost open
Cream 2 x 200 g.	80-100	10-15	Defrost open (cream is easy to whip even if parts of it are still slightly frozen)
Cake 1400 g.	60	60	Defrost open

The times quoted in the chart should be used as a guide only, as the speed of defrosting will depend on the kitchen temperature. For example, the colder the ambient temperature, the longer the defrosting time.

# Cleaning the Oven



Before cleaning always allow the cooling fan to cool the oven down before switching off at the electricity supply.

*This appliance cannot be cleaned with steam or with a steam cleaning machine.*

*The oven should be kept clean at all times. A build-up of fats or other foodstuffs could result in a fire, especially in the grill pan.*

## Cleaning materials

Before using any cleaning materials on your oven, check that they are suitable and that their use is recommended by the manufacturer.

Cleaners that contain bleach **should NOT** be used as they may dull the surface finishes. Harsh abrasives should also be avoided.

## External cleaning

Regularly wipe over the control panel, oven door and door seal using a soft cloth well wrung out in warm water to which a little washing up liquid has been added.



*To prevent damaging or weakening the door glass panels avoid the use of the following:*

- Household detergent and bleaches
- Impregnated pads unsuitable for non-stick saucepans
- Brillo/Ajax pads or steel wool pads
- Chemical oven pads or aerosols
- Rust removers
- Bath/Sink stain removers

Clean the outer and inner door glass using warm soapy water. Should the inner door glass become heavily soiled it is recommended that a cleaning product such as Hob Brite, or Bar Keepers Friend is used.



**DO NOT** clean the oven door while the glass panels are warm. If this precaution is not observed the glass panel may shatter.

*If the door glass panel becomes chipped or has deep scratches, the glass will be weakened and must be replaced to prevent the possibility of the panel shattering. Contact your local Service Centre who will be pleased to advise further.*

## Oven Cavity

The enamelled oven cavity is best cleaned whilst the oven is still warm.

Wipe the oven over with a soft cloth soaked in warm soapy water after each use. From time to time it will be necessary to do a more thorough cleaning, using a proprietary oven cleaner.

If the soilage has become set, after the oven has cooled down, the following process will help to soften the splatters to help make cleaning easier.

1. Place the grill/ meat pan on the oven shelf positioned in the lowest runner.
2. Add a few drops of washing-up liquid to the pan and fill to about 12 mm. with boiling water from the kettle.
3. Close the oven door, turn the oven function knob on fan oven  and set the thermostat knob on 50°C.
4. After 15 minutes, turn off the thermostat and allow the fan oven to continue without heat for a further 5 minutes, when the temperature of the water will have cooled down.
5. Carefully remove the pan of water from the oven and use normal oven cleaners to clean away soil residues.
6. Leave a little of the soapy water to soak into any burned on spillage on the floor of the oven for a longer time if necessary.

## Oven Shelves and Shelf Supports

To clean the oven shelves and the shelf supports, soak in warm soapy water and remove stubborn marks with a well wetted soap impregnated pad. Rinse well and dry with a soft cloth.

The shelf supports can be removed for easy cleaning (see diagram). Please, ensure the retaining nuts are secure when refitting the shelf support.

 When cleaning the shelf supports, take care not to remove the lubricating grease behind the telescopic runners. This is meant to ensure their good operation.

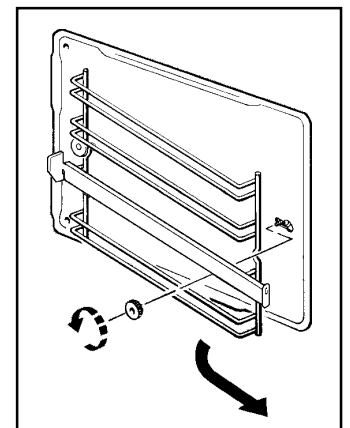





# Cleaning the hinged grill

This model has been fitted with a hinged grill element to enable you to clean the roof of the oven easily.

 **Before proceeding ensure the oven is cool and is disconnected from the electricity supply.**

-  1) Undo the screws which hold the grill in place (see diagram). When doing this operation for the first time, we recommend using a screwdriver.
- 2) Then gently pull the grill downward to allow access to the oven roof (see diagram).
- 3) Clean the oven roof with a suitable cleaner and wipe dry before replacing the hinged grill element.
- 4) Gently push up the grill element into place and firmly screw into place the holding nuts.

 **Ensure the grill holding nuts are firmly in place to avoid the grill falling down when in use.**

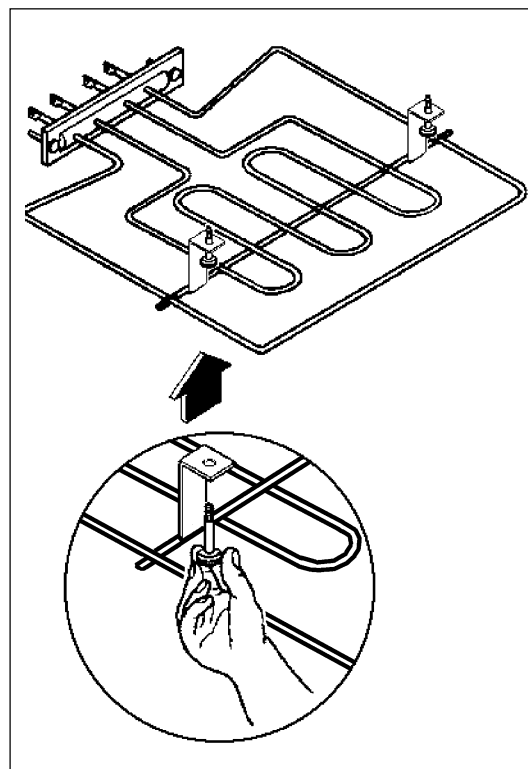

# Replacing the Oven Light

 **Disconnect the appliance.**

If the oven bulb needs replacing, it must comply with the following specifications:

- Electric power: 15W,
- Electric rate: 230-240 V (50 Hz),
- Resistant to temperatures of 300°C,
- Connection type: E14.

These bulbs are available from your local Service Force Centre.

To replace the faulty bulb:

-  1. Ensure the oven is disconnected from the electrical supply.
2. Turn the glass cover anticlockwise.
3. Remove the faulty bulb and replace with the new one.
4. Refit the glass cover.
5. Reconnect to the electrical supply.

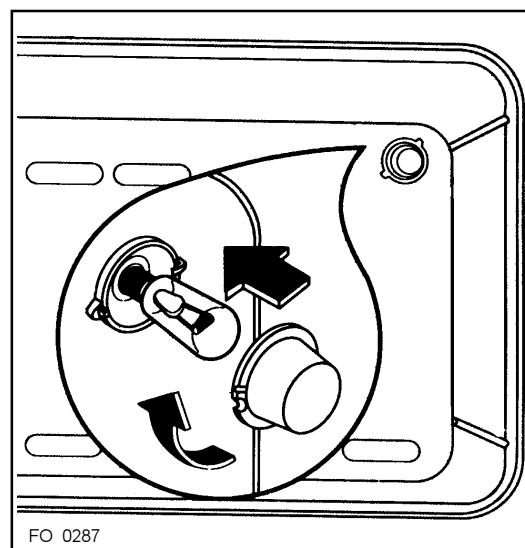

# Something not working...

If the oven is not working correctly, please carry out the following checks, before contacting your local Service Centre. **IMPORTANT:** If you call out an engineer to a fault listed below, or to repair a fault caused by incorrect use or installation, a charge will be made even if the appliance is under guarantee.

SYMPTOM	SOLUTION
<ul style="list-style-type: none"> <li>■ The oven does not come on</li> </ul>	<ul style="list-style-type: none"> <li>◆ Check the oven is in manual operation and that both a cooking function and temperature have been selected.</li> <li>◆ Check the oven is wired in properly, and the socket switch or the switch from the mains supply to the oven are ON.</li> </ul>
<ul style="list-style-type: none"> <li>■ The oven temperature light does not come on</li> </ul>	<ul style="list-style-type: none"> <li>◆ Select a temperature with the thermostat control knob</li> <li>◆ Select a function with the oven function control knob.</li> </ul>
<ul style="list-style-type: none"> <li>■ The oven light does not come on</li> </ul>	<ul style="list-style-type: none"> <li>◆ Select a function with the oven function control knob</li> <li>◆ Check the light bulb, and replace it if necessary (see "Replacing the Oven Light")</li> </ul>
<ul style="list-style-type: none"> <li>■ It takes too long to finish the dishes, or they are cooked too fast.</li> </ul>	<ul style="list-style-type: none"> <li>◆ The temperature may need adjusting</li> <li>◆ Refer to the contents of this booklet, especially to the chapter "Using the Oven".</li> </ul>
<ul style="list-style-type: none"> <li>■ Steam and condensation settle on the food and the oven cavity.</li> </ul>	<ul style="list-style-type: none"> <li>◆ Leave dishes inside the oven no longer than 15-20 minutes after the cooking is completed.</li> </ul>
<ul style="list-style-type: none"> <li>■ The electronic programmer does not work</li> </ul>	<ul style="list-style-type: none"> <li>◆ Check the instructions for the programmer.</li> </ul>
<ul style="list-style-type: none"> <li>■ The oven fan is noisy</li> </ul>	<ul style="list-style-type: none"> <li>◆ Check that shelves and bakeware are not vibrating in contact with the oven back panel.</li> </ul>

## Service and Spare Parts



In the event of your appliance requiring service, or if you wish to purchase spare parts, please contact your local Service Force Centre by telephoning:

**0870 5 929929**

Your telephone call will be automatically routed to the Service Force Centre covering your post code area.

For the address of your local Service Force Centre and further information about Service Force, please visit the website at [www.serviceforce.co.uk](http://www.serviceforce.co.uk)

Before calling out an engineer, please ensure you have read the details under the heading "Something Not Working."

When you contact the Service Force Centre you will need to give the following details:

1. Your name, address and post code
2. Your telephone number
3. Clear and concise details of the fault
4. The model and serial number of the appliance (found on the rating plate)
5. The purchase date

**Please note that a valid purchase receipt or guarantee documentation is required for in-guarantee service calls.**

# Customer Care Department

For general enquiries concerning your Zanussi appliance or for further information on Zanussi products, please contact our Customer Care Department by letter or telephone at the address below or visit our website at [www.zanussi.co.uk](http://www.zanussi.co.uk)

## Customer Care Department

Zanussi  
55-77 High Street  
Slough  
Berkshire  
SL1 1DZ  
08705 727727 (\*)

\* calls to this number may be recorded for training purposes.

# Guarantee Conditions

## Zanussi Guarantee conditions

We, Zanussi, undertake that if, within 24 months of the date of the purchase, this Zanussi appliance or any part thereof is proved to be defective by any reason only of faulty workmanship or materials, we will, at our option, repair or replace the same FREE OF ANY CHARGE for labour, materials or carriage on condition that:

- \* The appliance has been correctly installed and used only on the gas and electricity supply stated on the rating plate.
- \* The appliance has been used for normal domestic purpose only, and in accordance with the manufacturer's instructions.
- \* The appliance has not been serviced, maintained, repaired, taken apart or tampered with by any person not authorised by us.
- \* All service work under this guarantee must be undertaken by a Zanussi Service Centre.
- \* Any appliance or defective part replaced shall become the Company's property.
- \* This guarantee is in addition to your statutory and other legal rights.

Home visits are made between **8.30am and 5.30pm** Monday to Friday. Visits may be available outside these hours, in which case a **premium** will be charged.

## Exclusions

**This guarantee does not cover:**

- \* Damage or calls resulting from transportation, improper use or neglect, the replacement of any light bulbs or removable parts of glass or plastic.
- \* Costs incurred for calls to put right an appliance which is improperly installed or calls to appliance outside the United Kingdom.

- \* Appliances found to be in use within a commercial or similar environment, plus those which are the subject to rental agreements.
- \* Products of Zanussi manufacture which are not marketed by Zanussi.

## European Guarantee

If you should move to another country within Europe then your guarantee moves with you to your new home subject to the following qualifications:

- \* The guarantee starts from the date you first purchased your product.
- \* The guarantee is for the same period and to the same extent for labour and parts as exist in the new country of use for this brand or range of products.
- \* This guarantee relates to you and cannot be transferred to another user.
- \* Your new home is within the European Community (EC) or European Free Trade Area.
- \* The product is installed and used in accordance with our instructions and is only used domestically, i.e. a normal household
- \* The product is installed taking into account regulations in your new country.

Before you move, please contact your nearest Customer Care centre, listed below, to give them details of your new home. They will then ensure that the local Service Organisation is aware of your move and able to look after you and your appliances.

France	Senlis	+33 (0) 3 44 62 29 29
Germany	Nürnberg	+49 (0) 800 234 7378
Italy	Pordenone	+39 (0) 0434 39 4700
Sweden	Stockholm	+46 (0) 8 672 53 90
UK	Slough	+44 (0) 1753 219897

# Installation



The oven must be installed according to the instructions supplied.



This oven must be installed by **qualified personnel** to the relevant British Standards.

## Technical Data

### Dimensions of recess

Height	580 mm.
Width	560-570 mm.
Depth	550 mm.

### Dimensions of the oven cavity

Height	325 mm.
Width	420 mm.
Depth	390 mm.
Oven capacity	53 litres

## Heating elements rating

Oven elements	1,880 W
Top element	835 W
Bottom element	1,045 W
Convection element	2,088 W
Inner Grill element	1,830 W
Double Grill element	2,660 W
Oven Light	15 W
Cooling Fan	25 W
Convection Fan	30 W
Total Rating	2,700 W
Supply voltage (50 Hz)	230-240 V

# Electrical Connection

The oven is designed to be connected to 230-240V (50Hz) electricity supply.

The oven has an easily accessible terminal block which is marked as follows:

Letter L	-	Live terminal
Letter N	-	Neutral terminal
or E	-	Earth terminal



**THIS OVEN MUST BE EARTHED**

The cable used to connect the oven to the electrical supply must comply to the specifications given below.

### For Uk use only

Connection via	Min. size Cable/flex	Cable / flex type	Fuse
<ul style="list-style-type: none"> <li>13 A socket outlet</li> <li>13 A spur box</li> </ul>	2.5 mm <sup>2</sup>	3 core butyl insulated	13 A min.
<ul style="list-style-type: none"> <li>Cooker Control Circuit</li> </ul>	2.5 mm <sup>2</sup>	PVC/PVC twin and earth	15 A min. 20 A max.

### For Europe use only

Min. size Cable/flex	Cable / flex type	Fuse
1.5 mm <sup>2</sup>	H07 RN-F, H05 RN-F, H05 RR-F, H05 VV-F, H05 V2V2-F (T90), H05 BB-F	13 A

It is necessary that you install a double pole switch between the oven and the electricity supply (mains), with a minimum gap of 3mm between the switch contacts and of a type suitable for the required load in compliance with the current rules.

The switch must not break the yellow and green earth cable at any point.

### Important

After installation and connecting, the cable must be placed so that it cannot at any point reach a temperature of more than 50°C above the ambient temperature.

Before the oven is connected, check that the main fuse and the domestic installation can support the load; and that the power supply is properly earthed.

**The manufacturer disclaims any responsibility should these safety measures not be carried out.**

# Building In

Please ensure that when the oven is installed it is easily accessible for the engineer in the event of a breakdown.

## Building In

The surround or cabinet into which the oven will be built must comply with these specifications:

- the dimensions must be as shown in the relevant diagrams;
- the materials must withstand a temperature increase of at least 60°C above ambient;
- proper arrangements must be made of a continuous supply of air to the oven to prevent the oven overheating.

Dimensions of the oven and recess required are given in the relevant diagrams.

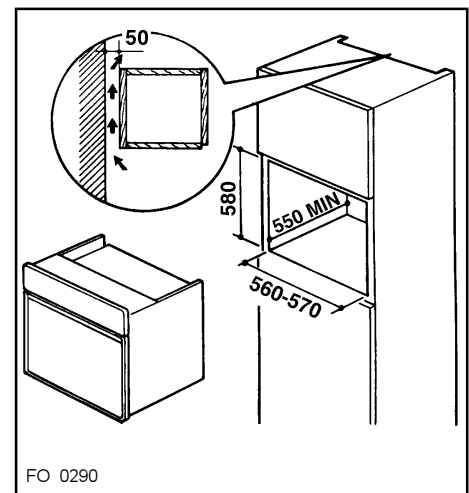
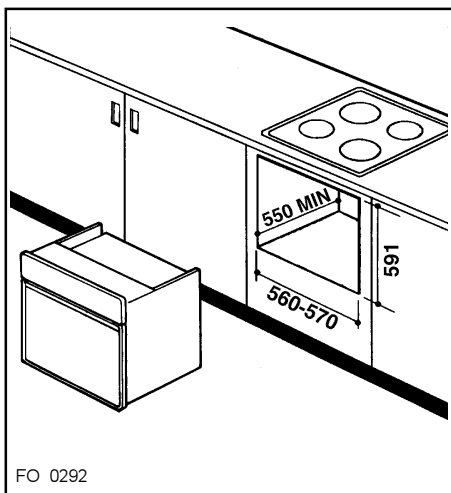
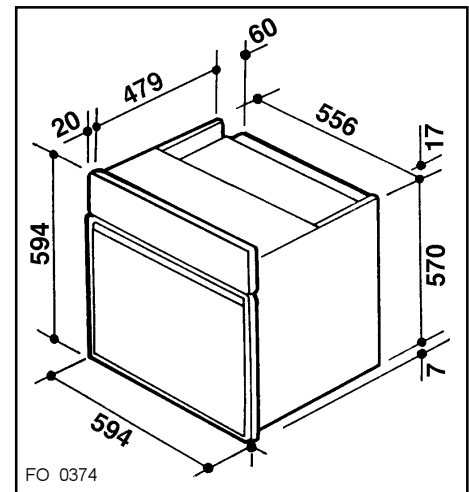

## Securing the Oven to the Cabinet

**i** The oven door can be fitted on the right or on the left.

- 1) Fit the appliance into the cabinet recess, open the oven door and unscrew the two upper screws of the door hinge.
- 2) Slightly slide forward the door in order to disengage it from the upper hinge.
- 3) Lift the oven door to disengage it from the lower hinge slipping of the pivot.
- 4) Secure the oven to the kitchen cabinet with four wood screws which fit the holes provided in the oven frame. Reassemble the oven door carrying out the above procedure in reverse.

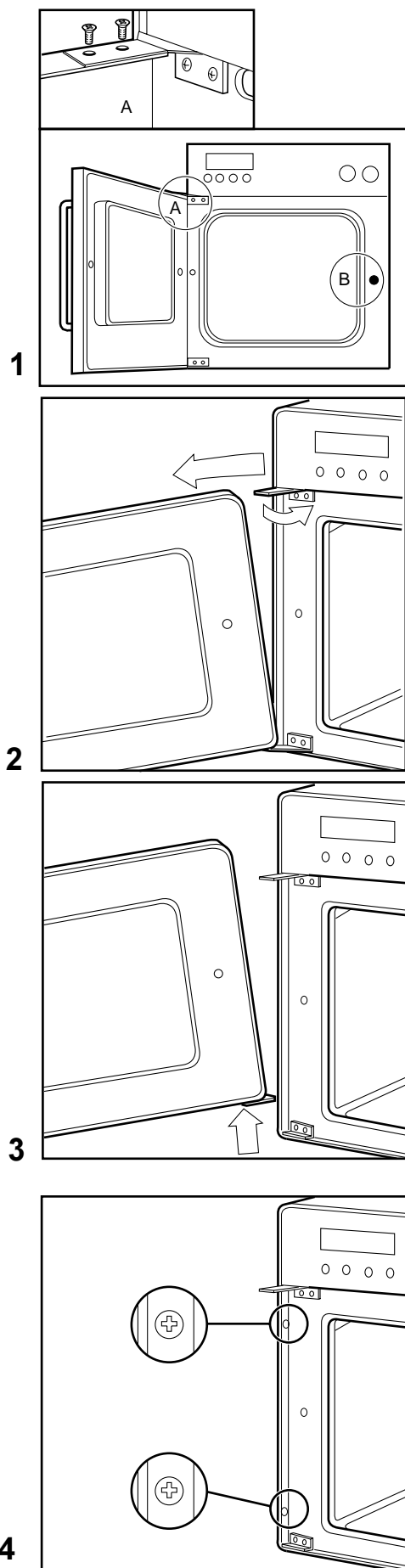



## CUSTOMER CARE

### Zanussi

55-77 High Street  
Slough  
Berkshire, SL1 1DZ  
Tel: 08705 727727

© Electrolux Household Appliances Limited 2002

 **From the Electrolux Group.** *The world's No.1 choice.*

*The Electrolux Group is the world's largest producer of powered appliances for kitchen, cleaning and outdoor use. More than 55 million Electrolux Group products (such as refrigerators, cookers, washing machines, vacuum cleaners, chain saws and lawn mowers) are sold each year to a value of approx. USD 14 billion in more than 150 countries around the world.*