

ZANUSSI

BUILT-IN OVEN

ZBF 569

INSTRUCTION BOOKLET

Please read this instruction booklet before using the appliance

GB

Important Safety Information



You **MUST** read these warnings carefully before installing or using the hob. If you need assistance, contact our Customer Care Department on 08705 727727

Installation

- This oven must be installed by qualified personnel to the relevant British Standards.
- This oven is heavy. Take care when moving it.
- Remove all packaging, both inside and outside the oven, before using the oven.
- Do not attempt to modify the oven in any way.

Child Safety

- This oven is designed to be operated by adults. Do not allow children to play near or with the oven.
- The oven gets hot when it is in use. Children should be kept away until it has cooled.

During Use

- This oven is intended for domestic cooking only. It is not designed for commercial or industrial purposes.
- Appliances become very hot with use, and retain their heat for long periods after use. Care should be taken to avoid touching heating elements inside the oven.
- **Always stand back from the oven when opening the oven door during cooking or at the end of it to allow any build up of steam or heat to release.**
- Never line any part of the oven with aluminium foil.
- Do not allow heatproof cooking material, e.g. roasting bags, to come into contact with oven elements.
- Never place plastic or any other material which may melt in or on the oven.
- Do not place sealed cans or aerosols inside the oven. They may explode if they are heated.
- Do not hang towels, dishcloths or clothes from the oven or its handle.
- Do not use this oven if it is in contact with water and never operate it with wet hands.
- Take great care when heating fats and oils as they will ignite if they become too hot.
- Always use oven gloves to remove and replace food in the oven.
- Ensure that all control knobs are in the OFF position when not in use.
- Do not leave cookware containing foodstuffs, e.g. fat or oil in or on the oven in case it is inadvertently switched ON.

- When using other electrical appliances, ensure the cable does not come into contact with the hot surfaces of the oven.

Maintenance and Cleaning

- Only clean this oven in accordance with the instructions.
- The oven should be kept clean at all times. A build-up of fats or other foodstuffs could result in a fire, especially in the grill pan.
- Never use steam or high pressure steam cleaners to clean the appliance.
- Always allow the oven to cool down and switch off the electrical supply before carrying out any cleaning or maintenance work.

Service

- This oven should only be repaired or serviced by an authorised Service Engineer and only genuine approved spare parts should be used.

Environmental Information

- After installation, please dispose of the packaging with due regard to safety and the environment.
- When disposing of an old appliance, make it unusable, by cutting off the cable. Remove any door catches, to prevent small children being trapped inside.



The symbol  on the product or on its packaging indicates that this product may not be treated as household waste. Instead it shall be handed over to the applicable collection point for the recycling of electrical and electronic equipment. By ensuring this product is disposed of correctly, you will help prevent potential negative consequences for the environment and human health, which could otherwise be caused by inappropriate waste handling of this product.

For more detailed information about recycling of this product, please contact your local city office, your household waste disposal service or the shop where you purchased the product.

Keep this instruction book for future reference and ensure it is passed on to any new owner.

Contents

For the User

Important Safety Information	2
Description of the Oven	4
Controls	5
Before the First Use	7
Electronic Programmer	8
Using the Oven	10
Hints and Tips	10
The Fan Oven	11
Cooking Chart - Fan Oven	12
Grilling	13
Defrosting	14
Cleaning the Oven	15
Care of Catalytic Liners	18
Something not Working	18
Service and Spare Parts	19
Customer Care Department	19
Guarantee Conditions	

For the Installer

Installation	21
Technical Data	21
Electrical Connection	21
Building In	22

Guide to use the instructions

The following symbols will be found in the text to guide you throughout the Instructions:



Safety Instructions



Step by step instructions for an operation



Hints and Tips



Environmental information



This appliance complies with the following **E.E.C. Directives:**

***73/23 - 90/683** (Low Voltage Directive);

***93/68** (General Directives);

***89/336** (Electromagnetic Compatibility Directive) and subsequent modifications.

Description of the Oven

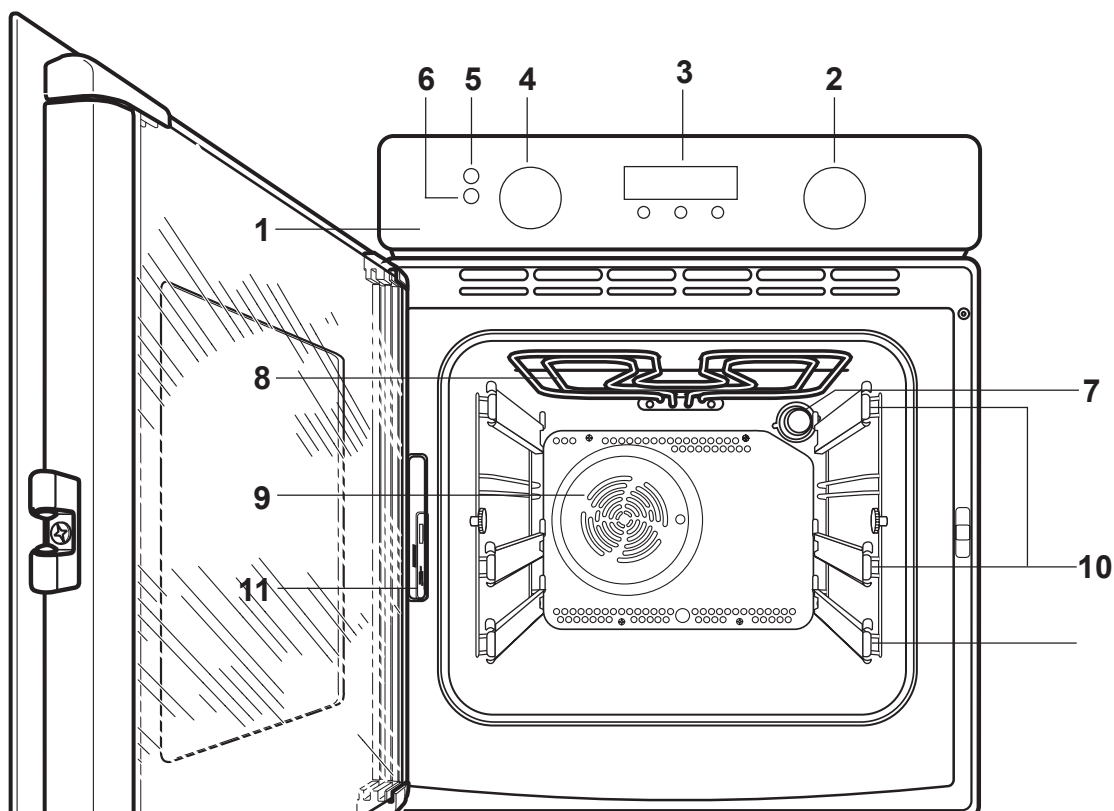





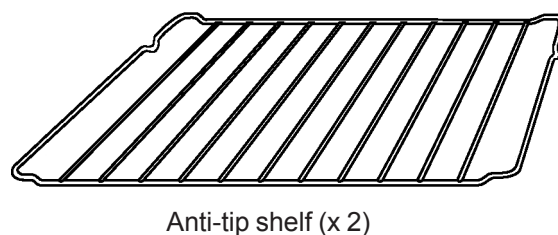
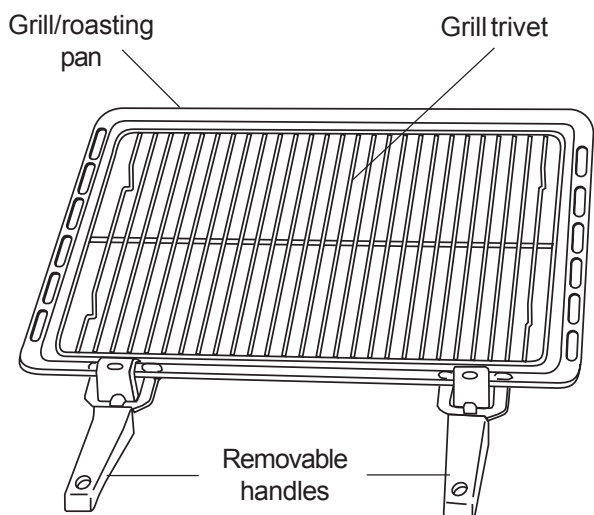

- | | |
|-------------------------------|-------------------------------|
| 1. Control panel | 7. Oven Light |
| 2. Oven Control Function Knob | 8. Grill |
| 3. Electronic Programmer | 9. Oven Fan |
| 4. Thermostat Control Knob | 10. Telescopic shelf supports |
| 5. Mains on Light | 11. Rating Plate |
| 6. Thermostat Control Light | |

Oven accessories



Controls

Oven Function Control Knob

- 0** The oven is off
-  **Oven light** - The oven light will be on without any cooking function
-  **Inner grill element only** - Can be used for grilling small quantities
-  **Full Grill** - The full grill element will be on. Recommended for large quantities.
-  **Thermal Grilling** - This function offers an alternative method of cooking food items, normally associated with conventional grilling. The grill element and the oven fan operate together, circulating hot air around the food. **When using the thermal grill cooking function, select a maximum temperature of 200°C.**
-  **Fan cooking** - This allows you to roast or roast and bake simultaneously using any shelf, without flavour transference
-  **Defrost Setting** - This setting is intended to assist in thawing of frozen food.

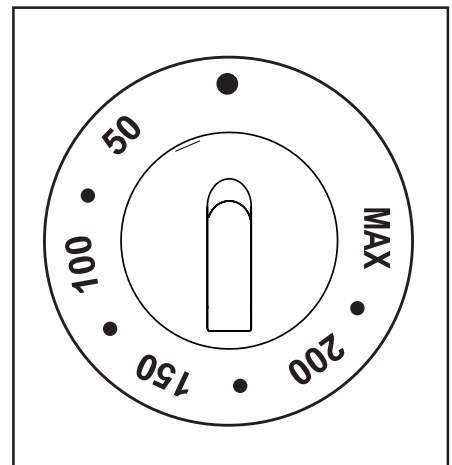
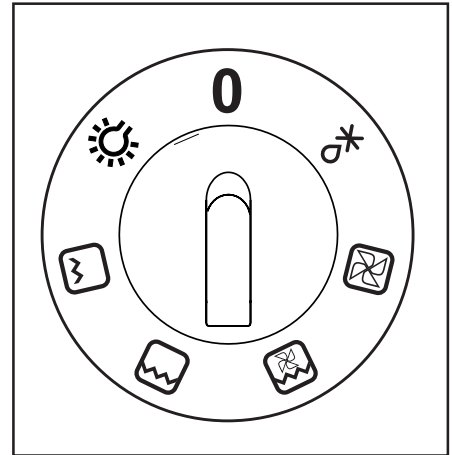

Thermostat Control Knob (°C)

Turn the thermostat control knob clockwise to select temperatures between 50°C and 230°C (MAX).

Thermostat Control Light

The thermostat control light will come on when the thermostat control knob is turned. The light will remain on until the correct temperature is reached. It will then cycle on and off to show the temperature is being maintained.

Mains on Light

The mains on light will come on when the oven function control knob is set.

The Safety Thermostat

This oven is provided with a safety thermostat. In case of malfunctioning of the main thermostat, and consequential over-heating, the safety device will stop the power supply to the appliance. If this happens, call your local Service Force Centre. Under no circumstances should you attempt to repair the appliance yourself.

The cooling fan

The cooling fan operates during cooking. Air is expelled through vents between the oven door and the control panel, as shown in the diagram.

The cooling fan may run on after the oven is switched off to keep the controls cool. This is quite normal.

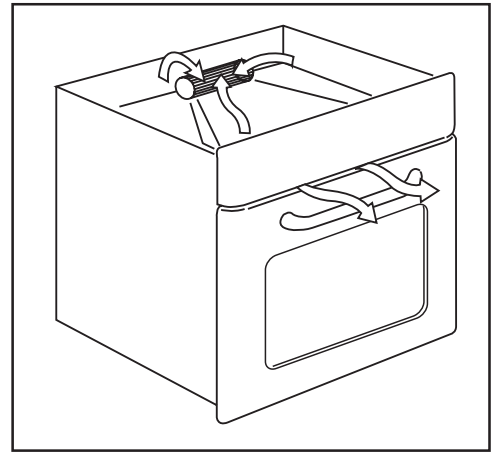

Shelf supports

The oven has four shelf levels. The shelf positions are counted from the bottom of the oven as shown in the diagram.

Shelf levels 1, 2 and 4 are fitted with telescopic shelf supports, to allow an easier operation when inserting or removing the shelves.

Pull the right and left hand telescopic shelf supports completely out, as shown in figure 4.

Place the shelf or the grill pan on the telescopic shelf supports, then gently push them all inside the oven (see diagram).

Do not attempt to close the oven door if the telescopic shelf supports are not completely inside the oven. This could damage the door enamel and glass.

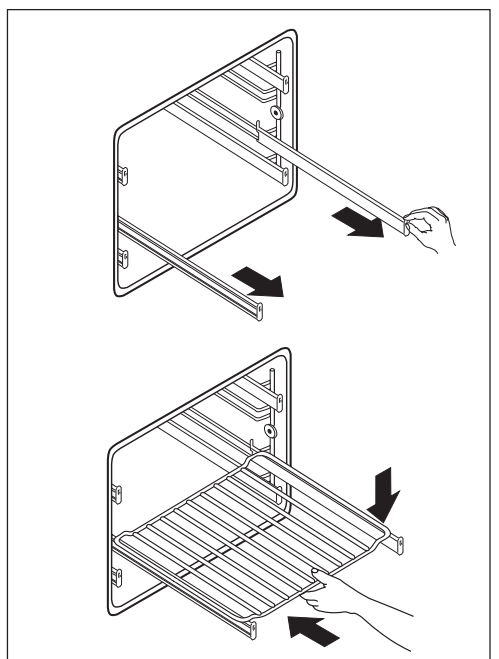
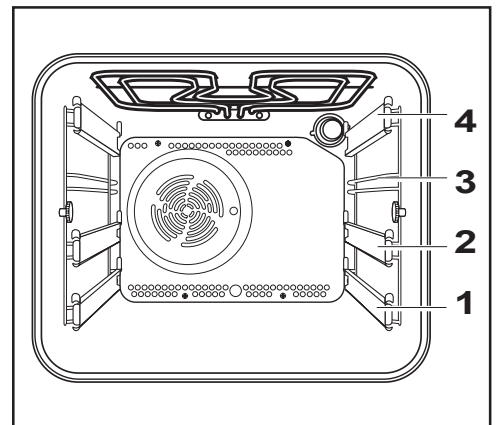

Before the First Use



Remove **all packaging**, both inside and outside the oven, before using the oven.

Before first use, the oven should be heated without food. During this time, an unpleasant odour may be emitted. This is quite normal. Ensure the room is well ventilated.



The oven will work only if the time of day has been set (please read the relevant instructions).



1. Set the time of day with the electronic programmer (see chapter "Electronic Programmer").
2. Switch the oven function control knob to fan cooking .
3. Set the thermostat control knob to MAX.
4. Open a window for ventilation.
5. Allow the oven to run empty for approximately 45 minutes.

This procedure should be repeated with the full grill  function for approximately 5-10 minutes.



To open the oven door, always catch the handle in its central part.

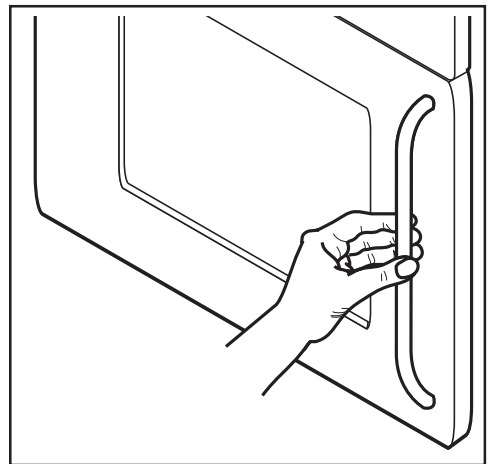

Electronic Programmer

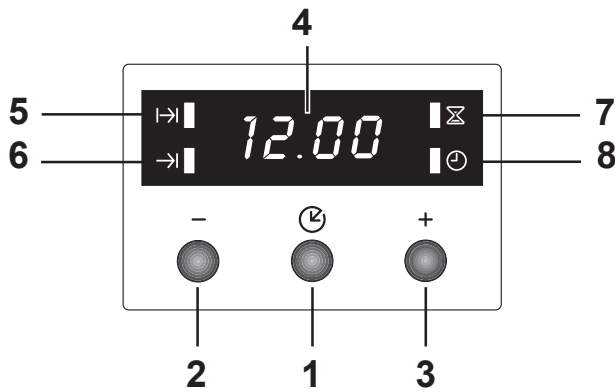

1. Push button for selecting a function ⌚
2. Decreasing control button “-”
3. Increasing control button “+”
4. Display
5. “Cooking Duration” pilot lamp I->I
6. “End of cooking” pilot lamp ->I
7. “Minute minder” pilot lamp Σ
8. “Time of day” pilot lamp ⌚

i The oven will only work if the time of day has been set. However, the oven can also be operated without any programme.

Setting the time of day ⌚

When the power supply is switched on, or after a power failure, the “Time of day” pilot lamp ⌚ will flash on the display.

To set the correct time of day:

1. Press button “+” or “-”.
2. After the setting is carried out, wait for 5 seconds: the “Time of day” pilot lamp ⌚ will go out and the display will show the set time. The appliance is ready for use.

To reset the correct time of day:

1. Press button ⌚ repeatedly to select the “Time of day” function. The relevant pilot lamp will start flashing. Then proceed as described above. The time of day can only be reset if no automatic function (cook duration I->I or end of cooking ->I) has been set.

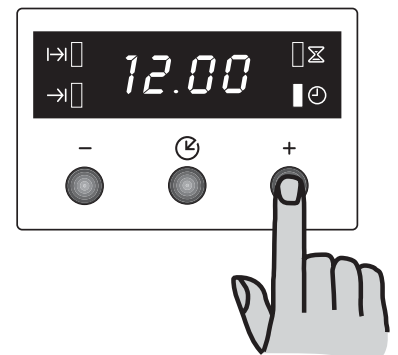

“Cooking Duration” function I->I

This function allows the oven to automatically switch off at the end of a programmed cooking duration time. Place food in the oven, select a cooking function and adjust the cooking temperature. Press button ⌚ repeatedly to select the “Cooking Duration” function. The relevant pilot lamp I->I will start flashing. Then, proceed as follows:

To set the duration time:

1. Press button “+” or “-”.
2. After the setting is carried out, wait for 5 seconds: the “Cooking Duration” pilot lamp I->I will come on and the display will revert to the time of day.
3. When cooking time is over, the oven will be switched off automatically and an acoustic alarm will be heard, while the pilot lamp will start flashing. Turn the oven function and the thermostat control knob to zero.

To switch off the acoustic alarm, press any button.

NOTE: turning the acoustic alarm off will reset the oven to manual, and if the oven function and the thermostat knobs are not set to zero the oven will start to heat again.

To cancel the duration time:

1. Press button ⌚ repeatedly to select the “Cooking Duration” function. The relevant pilot lamp I->I will flash and the display will show the remaining cooking time.
2. Press button “-” until the display shows “0:00”. After 5 seconds the pilot lamp will go out and the display will revert to the time of day.

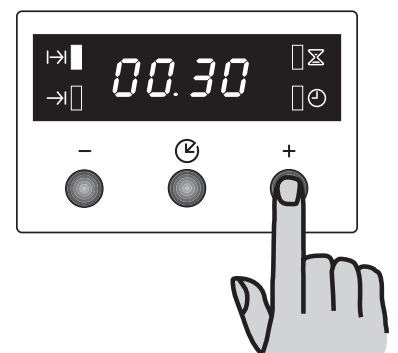
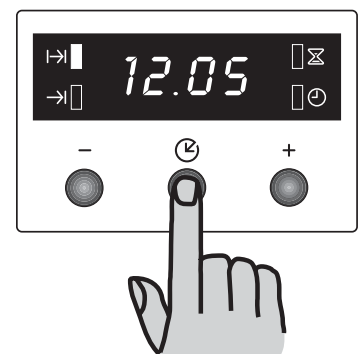

“End of cooking” function →|

With this function, you can set the oven to switch off automatically when a programmed end of cooking time is over. Place food in the oven, select a cooking function and adjust the cooking temperature. Press button  repeatedly to select the “End of cooking” function. The relevant pilot lamp →| will start flashing. Then, proceed as follows:

To set the End of cooking time:

1. Press button “+” or “-”.
2. After the setting is carried out, wait for 5 seconds: the “End of cooking” pilot lamp →| will come on and the display will revert to the time of day.
3. When cooking time is over, the oven will be switched off automatically and an acoustic alarm will be heard, and the pilot lamp will start flashing. Turn the oven function and the thermostat control knob to zero.

To switch off the acoustic alarm, press any button. **NOTE:** turning the acoustic alarm off will reset the oven to manual, and if the oven function and the thermostat knobs are not set to zero the oven will start to heat again.

To cancel the End of cooking time:

1. Press button  repeatedly to select the “End of cooking” function. The relevant pilot lamp →| will flash and the display will show the programmed End of cooking time.
2. Press button “-” until the display shows the current time of day. The programmer will beep and the pilot lamp will go out.

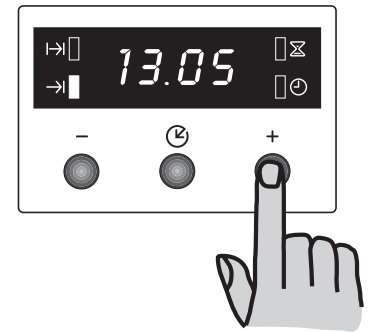
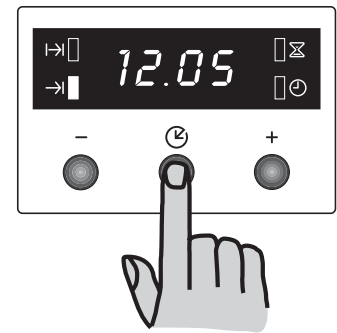

“Cooking duration” |→| and “End of cooking time” →| combined

The functions “Cooking duration” and “End of cooking time” can be used simultaneously to set the oven to switch on and off automatically at a later time.

1. With the “Cooking duration” function |→| (carry out the cooking duration setting as described in the relevant chapter) set the duration time. Then, press button : the display will show the programmed setting.
2. With the “End of cooking time” function →| (carry out the End of cooking setting as described in the relevant chapter) set the end of cooking time. The relevant pilot lamps will come on and the display will show the time of day. The oven will switch on and off according to the set programmes.

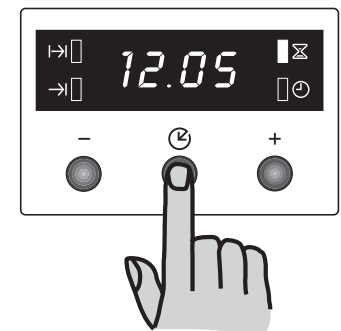

“Minute minder” function ⌚

The minute minder alarm will sound at the end of a timed period, but THE OVEN WILL REMAIN ON, if it is in use.

To set the minute minder:

1. Press button  repeatedly to select the “Minute minder” function. The relevant pilot lamp ⌚ will start flashing.
2. Then, press button “+” or “-” (maximum: 2 hours, 30 minutes).
3. After the setting is carried out, wait for 5 seconds: the “Minute minder” pilot lamp ⌚ will come on.
4. At the end of the timed period, the pilot lamp will start flashing and an acoustic alarm will be heard. To switch off the acoustic alarm, press any button.

To cancel the minute minder:

1. Press button  repeatedly to select the “Minute minder” function. The relevant pilot lamp ⌚ will flash and the display will show the remaining time.
2. Press button “-” until the display shows “0:00”. After 5 seconds the pilot lamp will go out and the display will revert to the time of day.

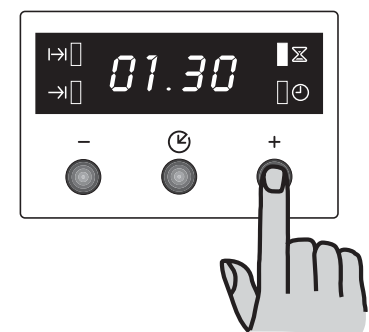

How to switch off the display

1. Press two or three programmer push buttons simultaneously and keep them pressed for about 5 seconds. The display will switch off.
2. To switch on the display, press any button.

The display can be switched off only if no other functions have been set.

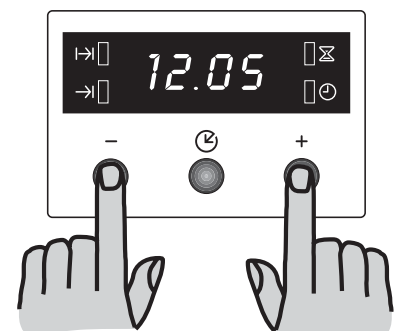

Using the Oven



Always cook with the oven door closed.

*Stand clear when opening the drop down oven door. **Do not** allow it to fall open - support the door using the door handle, until it is fully open.*



The oven has four shelf levels, and is supplied with two shelves. The shelf positions are counted from the bottom of the oven.

It is important that these shelves are correctly positioned as shown in the diagram.

Do not place cookware directly on the oven base.



Attention! - Do not place objects on the oven base and do not cover any part of the oven with aluminium foil while cooking, as this could cause a heat build-up which would affect the baking results and damage the oven enamel. Always place pans, heat-resisting pans and aluminium trays on the shelf which has been inserted in the shelf runners.

Hints and Tips

Condensation and Steam

The oven is supplied with an exclusive system which produces a natural circulation of air and the constant recycling of steam. This system makes it possible to cook in a steamy environment and keep the dishes soft inside and crusty outside. Moreover, the cooking time and energy consumption are reduced to a minimum. During cooking steam may be produced which can be released when opening the oven door. This is absolutely normal.



However, always stand back from the oven when opening the oven door during cooking or at the end of it to allow any build up of steam or heat to release.



When food is heated, it produces steam in the same way as a boiling kettle does. When steam comes in contact of the oven door glass, it will condense and produce water droplets. To reduce condensation, ensure the oven is well heated before placing food in the oven cavity. A short oven pre-heating (about 10 minutes) will then be necessary before anycooking. We recommend you to wipe away condensation after each use of the appliance.

Cookware

- Use any oven proof cookware which will withstand temperatures of 230°C.
- Baking trays, oven dishes, etc. should not be placed directly against the grid covering the fan at the back of the oven, or placed on the oven base.
- Do not use baking trays larger than 30 cm x 35 cm (12 in x 14 in) as they will restrict the circulation of heat and may affect performance.

The effects of dishes on cooking results

Dishes and tins vary in their thickness, conductivity, colour, etc. which affects the way they transmit heat to the food inside them.

- A** Aluminium, earthenware, oven glassware and bright shiny utensils reduce cooking and base browning.
- B** Enamelled cast iron, anodized aluminium, aluminium with non-stick interior and coloured exterior and dark, heavy utensils increase cooking and base browning.

The Fan Oven

The air inside the oven is heated by the element around the fan situated behind the back panel. The fan circulates hot air to maintain an even temperature inside the oven.

The advantage of cooking with this function is energy saving through:

- **Faster Preheating**

As the fan oven quickly reaches temperature, it is not usually necessary to preheat the oven although you may find that you need to allow an extra 5-7 minutes on cooking times. For recipes which require higher temperatures, best results are achieved if the oven is preheated first, e.g. bread, pastries, scones, souffles, etc.

- **Lower Temperatures**

Fan oven cooking generally requires lower temperatures than conventional cooking.

Follow the temperatures recommended in the cooking chart. Remember to reduce temperatures by about 20-25°C for your own recipes which use conventional cooking.

- **Even Heating for Baking**

The fan oven has uniform heating on all shelf positions. This means that batches of the same food can be cooked in the oven at the same time. However, the top shelf may brown slightly quicker than the lower one. This is quite usual. There is no mixing of flavours between dishes.

How to use the Fan Oven

1. Turn the oven function control knob to .
2. Turn the thermostat control to the required temperature.

Things to note

- The oven light will come on when the oven function control knob is set.
- The oven fan will operate continually during cooking.
- The thermostat control light will remain on until the correct temperature is reached. It will then cycle on and off to show the temperature is being maintained.

The cooling fan

During cooking the cooling fan will operate continually. It may run on after the oven is switched off to keep the controls cool. This is quite normal.

NOTE

The action of the cooling fan will depend on how long the oven has been used and at what temperature. It may not switch in at all at lower temperature settings nor run on where the oven has only been used for a short time.

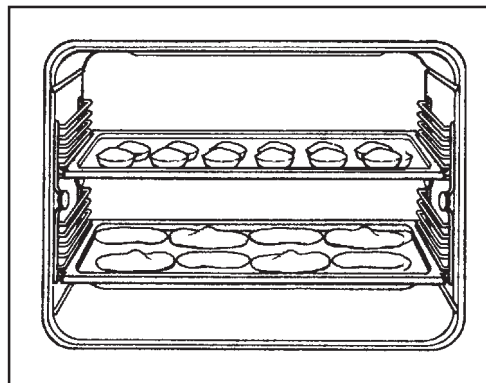



Hints and Tips

- Shelf positions are not critical, but make sure the shelves are evenly spaced.
- When cooking more than one dish in the fan oven, place dishes centrally on the shelves rather than several dishes on one shelf.
- When the oven is full, you may need to allow slightly longer cooking time.
- When the oven is full of the same food, e.g. equal trays of small cakes or equal size victoria sandwich cakes, then they will be cooked in the same time and removed from the oven together. When different sizes of trays or types of food, e.g. biscuits and cakes are cooked, they will not necessarily be ready together.
- The fan oven can be used to heat foods through without thawing first, e.g. fruit tarts, mince pies, sausage rolls, and other small pastry items. Use a temperature of 190-200°C and allow 20-40 minutes (depending on the quantity of food in the oven).
- The use of too high temperatures can cause uneven browning. Check with the recommendations for oven temperatures given in the cooking charts, but be prepared to adjust the temperature, if necessary. Remember to reduce temperatures by about 20-25°C for your own conventional recipes.
- When roasting do use the trivet in the meat tin. Fat and meat juices will drain into the meat tin below and can be used to make gravy. The trivet also prevents splashes of fat from soiling the oven interior.
- The meat tin **should not** be placed on a heated hotplate as this may cause the enamel to crack.

Cooking Chart- Fan Oven

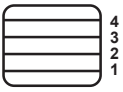
i Cooking times in the tables do not include pre-heating. We recommend to pre-heat the oven for about 10 minutes before cooking.

Weight (gr.)	TYPE OF DISH	Level 	cooking temperature (°C)	Cooking time  minutes	NOTES
	CAKES				
	Whisked recipes	2 (1 and 3)*	160	45 ~ 60	In cake mould
	Shortbread dough	2 (1 and 3)*	160	20 ~ 30	In cake mould
	Butter-milk cheese cake	2	150	60 ~ 80	In cake mould
	Apple cake	2 (1 and 3)*	170	40 ~ 60	In cake mould
	Strudel	2	150	60 ~ 80	
	Jam-tart	2 (1 and 3)*	160	30 ~ 40	
	Fruit cake	1	160	45 ~ 60	In bread tin
	Sponge cake	2 (1 and 3)*	160	30 ~ 40	In cake mould
	Christmas cake	1	160	40 ~ 60	In cake mould
	Plum cake	1	160	50 ~ 60	In bread pan
	Small cakes	2 (1 and 3)*	160	25 ~ 35	In baking tray
	Biscuits	2 (1 and 3)*	150	20 ~ 30	In baking tray
	Meringues	2 (1 and 3)*	100	90 ~ 120	In baking tray
	Buns	2 (1 and 3)*	180	12 ~ 20	In baking tray
	Pastry: Choux	2 (1 and 3)*	190	15 ~ 25	In baking tray
	BREAD AND PIZZA				
1000	White bread	2	180	40 ~ 60	1-2 pieces
500	Rye bread	1	180	30 ~ 45	In bread tin
500	Bread rolls	2 (1 and 3)*	175	20 ~ 35	6-8 rolls
250	Pizza	2 (1 and 3)*	190	15 ~ 30	on baking tray
	FLANS				
	Pasta flan	2 (1 and 3)*	175	40 ~ 50	in mould
	Vegetable flan	2 (1 and 3)*	175	45 ~ 60	in mould
	Quiches	2 (1 and 3)*	180	35 ~ 45	in mould
	Lasagne	2	160	45 ~ 60	in mould
	Cannelloni	2	175	40 ~ 55	in mould
	MEAT				
1000	Beef	2	175	50 ~ 70	On grid
1200	Pork	2	175	100 ~ 130	On grid
1000	Veal	2	175	90 ~ 120	On grid
1500	English roast beef				
1500	rare	2	200	50 ~ 60	On grid
1500	medium	2	200	60 ~ 70	On grid
1500	well done	2	200	70 ~ 80	On grid
2000	Shoulder of pork	2	170	120 ~ 150	With rind
1200	Shin of pork	2	160	100 ~ 120	2 pieces
1200	Lamb	2	175	110 ~ 130	Leg
1000	Chicken	2	175	60 ~ 80	Whole
4000	Turkey	2	160	210 ~ 240	Whole
1500	Duck	2	160	120 ~ 150	Whole
3000	Goose	2	160	150 ~ 200	Whole
1200	Rabbit	2	175	60 ~ 80	Cut in pieces
1500	Hare	2	175	150 ~ 200	Cut in pieces
800	Pheasant	2	175	90 ~ 120	Whole
	Meat loaf	2	160	40 ~ 60	in bread pan
	FISH				
1200	Trout/Sea bream	2 (1 and 3)*	175	30 ~ 40	3-4 fishes
1500	Tuna fish/Salmon	2 (1 and 3)*	175	25 ~ 35	4-6 fillets

This chart is intended as a guide only. It may be necessary to increase or decrease the temperature to suit your individual requirements. Only experience will enable you to determine the correct setting for your personal requirements.

(*) If you need to cook more than one dish at the same time, we recommend you to place them on the levels quoted between brackets. Shelf positions are counted from bottom of the oven.

If you wish to cook more than one dish at the same time, we suggest that you change the cooking levels of your dishes during the last 5-10 minutes in order to obtain a more uniform colour of your dishes.

Grilling



Grilling must be carried out with the oven door closed.

The grill pan handles must be removed from the pan during grilling. Always use oven gloves to remove and replace the grill pan handles.

Ensure that you **support** the grill pan when removing it from the oven.

How to Use the Full Grill

1. Set the oven control function knob to .
2. Set the thermostat control knob to the required temperature.
3. Adjust the grid and grill pan runner position to allow for different thicknesses of food. Position the food close to the element for faster cooking and further away for more gentle cooking.

Preheat the grill on a full setting for a few minutes before sealing steaks or toasting. Adjust the heat setting and the shelf as necessary, during cooking.

During cooking, the cooling fan and the thermostat control light will operate in the same way as described for the fan oven function.

How to Use the Inner Grill Element

The inner grill provides quick direct heat to the central area of the grill pan. By using the inner grill element for cooking small quantities, it can help to save energy.

1. Set the oven control function knob to .
2. Set the thermostat control knob to the required temperature.
3. Adjust the grid and grill pan runner position to allow for different thicknesses of food and follow the instructions for grilling.

Hints and Tips

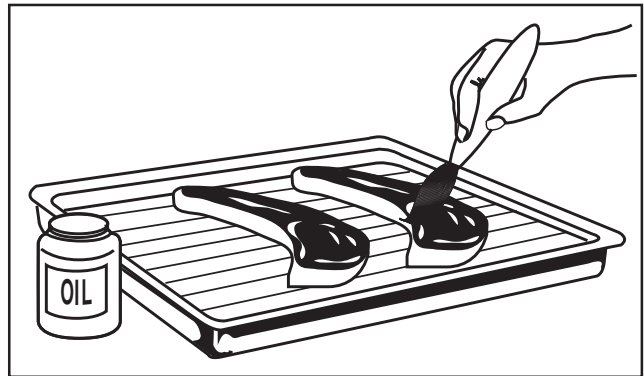

- Most foods should be placed on the grid in the grill pan to allow maximum circulation of air and to lift the food out of the fats and juices. Food such as fish, liver and kidneys may be placed directly on the grill pan, if preferred.
- Food should be thoroughly dried before grilling to minimise splashing. Brush lean meats and fish lightly with a little oil or melted butter to keep them moist during cooking.
- Accompaniments such as tomatoes and mushrooms may be placed underneath the grid when grilling meats
- When toasting bread, we suggest that the top runner position is used.
- The food should be turned over during cooking, as required.

The grill element is controlled by the thermostat. During cooking, the grill cycles on and off to prevent overheating.



Cooking chart - Grilling -

 Cooking times in the tables do not include pre-heating. We recommend to pre-heat the oven for about 10 minutes before cooking.

TYPE OF DISH	Quantity		Level 	Temperature °C	Cooking time (minutes) 	
	Pieces	Weight			Upper side	Lower side
Fillet steaks	4	800	3	250	12 ~ 15	12 ~ 14
Beef-steaks	4	600	3	250	10 ~ 12	6 ~ 8
Sausages	8	—	3	250	12 ~ 15	10 ~ 12
Pork chops	4	600	3	250	12 ~ 16	12 ~ 14
Chicken (cut in two)	2	1000	3	250	30 ~ 35	25 ~ 30
Kebabs	4	—	3	250	10 ~ 15	10 ~ 12
Chicken (breast)	4	400	3	250	12 ~ 15	12 ~ 14
Hamburger	6	600	3	250	10 ~ 15	8 ~ 10
Fish (fillets)	4	400	3	250	12 ~ 14	10 ~ 12
Sandwiches	4 - 6	—	3	250	3 ~ 7	—
Toast	4 - 6	—	3	250	2 ~ 4	2 ~ 3

The chart is intended as a guide only and should be adjusted according to taste. Cooking time depends on the thickness of the meat and not on its weight.

How to Use the Thermal Grill

Thermal grilling offers an alternative method of cooking food items normally associated with conventional grilling. The grill element and the oven fan operate alternately, circulating hot air around the food. The need to check and turn the food is reduced. Thermal grilling helps to minimize cooking smells in the kitchen.

With the exception of toast and rare steaks, you can thermally grill all the foods you would normally cook under a conventional grill. Cooking is more gentle, therefore food generally takes a little longer to cook with thermal grilling compared with conventional grilling. One of the advantages is that larger quantities can be cooked at the same time.

1. Turn the oven control function knob on .
2. Turn the thermostat control knob on the required temperature. **Select a maximum temperature of 200°C**
3. Adjust the grid and grill pan runner position to allow for different thicknesses of food and follow the instructions for grilling.

Cooking chart - Thermal grilling

 Cooking times in the tables do not include pre-heating. We recommend to pre-heat the oven for about 10 minutes before cooking.

When using the thermal grill cooking function, select a maximum temperature of 200°C.

TYPE OF DISH	Quantity (gr.)	Level 	Temperature °C	Time in minutes	
				lower side	upper side
Rolled joints (turkey)	1000	3	200	30 ~ 40	20 ~ 30
Chicken (cut in two)	1000	3	200	25 ~ 30	20 ~ 30
Chicken legs	—	3	200	15 ~ 20	15 ~ 18
Quail	500	2	200	25 ~ 30	20 ~ 25
Vegetable gratin	—	3	200	20 ~ 25	—
St. Jacques shells	—	3	200	15 ~ 20	—
Mackerel	—	3	200	15 ~ 20	10 ~ 15
Fish slices	800	3	200	12 ~ 15	8 ~ 10

Defrosting

The oven fan operates without heat and circulates the air, at room temperature, inside the oven. This increases the speed of defrosting. However, please note that the temperature of the kitchen will influence the speed of defrosting.

This function is particularly suitable for delicate food which could be damaged by heat, e.g. cream filled gateaux, iced cakes, pastries, bread and other yeast products.

How to Use Defrosting

1. Turn the oven function control knob to .
2. Ensure the thermostat control knob is in the **OFF** position.

Hints and Tips

Prepare foods in the same way as for conventional grilling. Brush lean meats and fish lightly with a little oil or butter to keep them moist during cooking.

Hints and Tips

- Cover food with a lid, aluminium foil or plastic film to prevent drying out during defrosting.
- **ALWAYS COOK THOROUGHLY IMMEDIATELY AFTER THAWING.**
- Frozen food should be placed in a single layer when ever possible and turned over half way through the defrosting process.
- Only joints of meat and poultry up to 2 kg. (4 lb.) are suitable for defrosting in this way.

Cleaning and Maintenance



Before any cleaning switch the oven off and let it cool down. Never use steam or steam machines to clean the appliance.

Important! Before carrying out maintenance and cleaning operations, make sure that your oven is disconnected from the mains power supply.

The oven should be kept clean at all times. A build-up of fats or other foodstuffs could result in a fire, especially in the grill pan.

Cleaning materials

Before using any cleaning materials on your oven, check that they are suitable and that their use is recommended by the manufacturer.

Cleaners that contain bleach should NOT be used as they may dull the surface finishes. Harsh abrasives should also be avoided.

External cleaning

Regularly wipe over the control panel, oven door and door seal using a soft cloth well wrung out in warm water to which a little liquid detergent has been added.

To prevent damaging or weakening the door glass panels avoid the use of the following:

- Household detergent and bleaches
- Impregnated pads unsuitable for non-stick saucepans
- Brillo/Ajax pads or steel wool pads
- Chemical oven pads or aerosols
- Rustremovers
- Bath/Sink stain removers

Clean the outer and inner door glass using warm soapy water. Should the inner door glass become heavily soiled it is recommended that a cleaning product such as Hob Brite is used. Do not use paint scrapers to remove soilage.



DO NOT clean the oven door while the glass panels are warm. If this precaution is not observed the glass panel may shatter.

If the door glass panel becomes chipped or has deep scratches, the glass will be weakened and must be replaced to prevent the possibility of the panel shattering. Contact your local Service Force Centre who will be pleased to advise further.

Oven Cavity

The enamelled base of the oven cavity is best cleaned whilst the oven is still warm.

Wipe the oven over with a soft cloth soaked in warm soapy water after each use. From time to time it will be necessary to do a more thorough cleaning, using a proprietary oven cleaner.



DO NOT attempt to clean catalytic liners.

Oven Shelves and Shelf Supports

To clean the oven shelves, soak in warm soapy water and remove stubborn marks with a well wetted soap impregnated pad. Rinse well and dry with a soft cloth. The shelf supports can be removed for easy cleaning.

Proceed as follows:

- 1) remove the front screw while keeping the shelf support in position with the other hand (see diagram 1);
- 2) disengage the rear hook and take off the shelf support (see diagram 2);
- 1) once the cleaning is carried out, refit the shelf supports following the procedure in reverse.

Please, ensure the retaining nuts are secure when refitting the shelf support.

When cleaning the shelf supports, take care not to remove the lubricating grease behind the telescopic runners. This is meant to ensure their good operation.

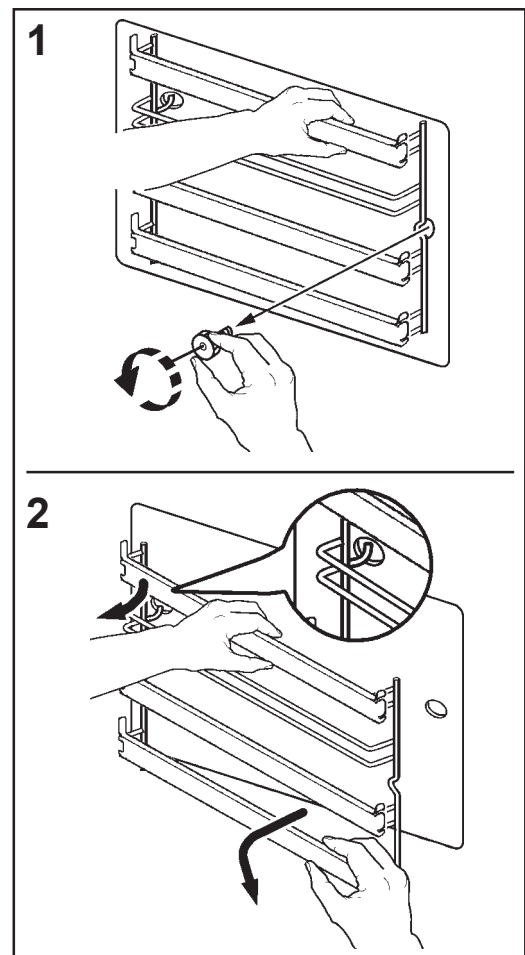

Cleaning the oven door

The following instructions are relevant to the oven door as it is supplied by the Manufacturer.

i If the oven door has been reversed, please note that the references to the right and left side have to be switched.

Figure 1. With the right hand, hold the aluminium slotted bar "A" while pulling off the inner glass support "B" with the left hand. Push the support towards the right to release it and then lift it up.

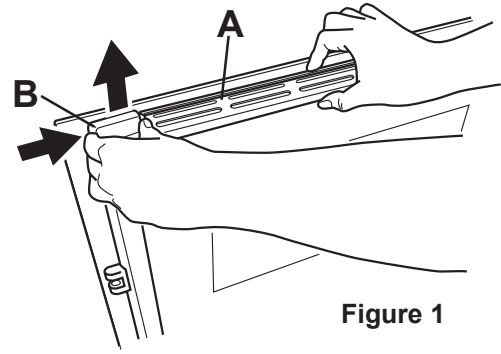

Figure 1

Figure 2. Remove the aluminium slotted bar "A" from support "C".

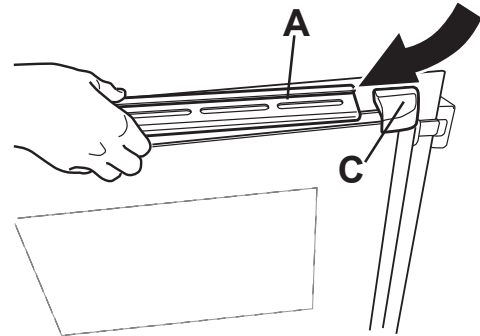

Figure 2

Figure 3. Hold firmly the inner glass "D" with the left hand and pull the support "C" off from its original position.

! Make sure that glass "D" is firmly held to prevent it from falling down.

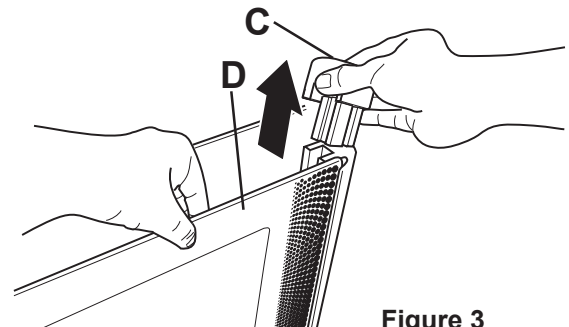

Figure 3

Figure 4. Hold tightly the inner glass "D" with both hands and remove it from its original position by sliding it up.

After removing the inner glass, clean the oven door and the glasses.

We recommend to clean the oven door using only a wet sponge and dry it up after cleaning with a soft cloth. Never use steel wool, acids or abrasive products as they can damage the oven surface.

After cleaning, place the inner glass "D" back in its original position.

i To correctly mount the inner glass "D" (with stripes along the sides) the surface marked with stripes has to face the oven door in a way that, when touching the surface on sight, the light roughness of the silk-screen printing is not perceptible.

After placing the inner glass back, insert support "C" in its position and, then:

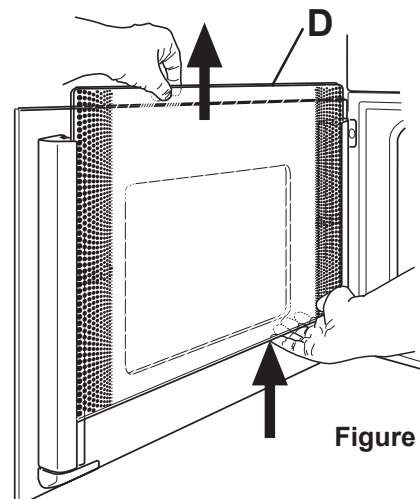

Figure 4

Figure 5. Place the right end of the aluminium bar “A” in the proper slot located in support “C”.

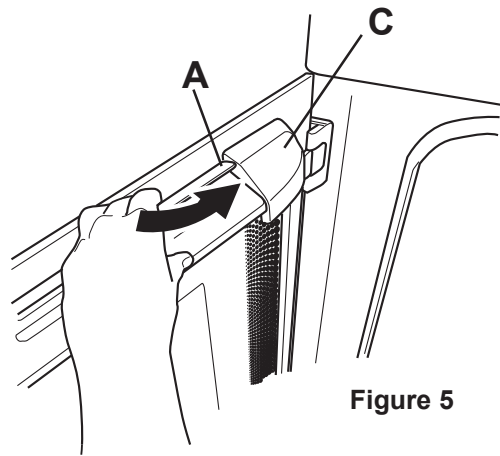

Figure 5

Figure 6. Place the left end of the aluminium bar “A” in the proper slot located in support “B”. Now, insert support “B” in its original position and make sure the assembly is well fixed and stable.

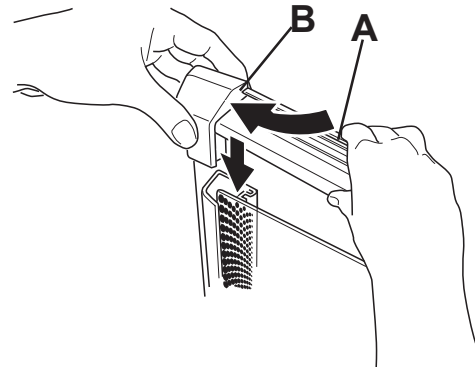

Figure 6

Models in stainless steel or aluminium:

We recommend to clean the oven door using only a wet sponge and dry it up after cleaning with a soft cloth. Never use steel wool, acids or abrasive products as they can damage the oven surface. Clean the oven control panel following the same precautions.



If necessary, it is possible to reverse the oven door. This operation should be carried out by authorized personnel ONLY.

Customers are recommended not to carry out this operation themselves.



This will be a chargeable visit.

Replacing the Oven Light

If the oven bulb needs replacing, it must comply with the following specifications:

- Electric power: 15 W/25 W,
- Electric rate: 230 V (50 Hz),
- Resistant to temperatures of 300°C,
- Connection type: E14.

These bulbs are available from your local Service Force Centre.

 To replace the faulty bulb 

1. Ensure the oven is disconnected from the electrical supply.
2. Turn the glass cover anticlockwise.
3. Remove the faulty bulb and replace with the new one.
4. Refit the glass cover.
5. Reconnect to the electrical supply.

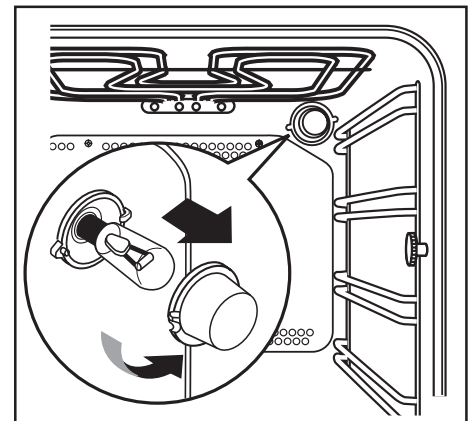

Care of Catalytic Liners

Catalytic liners destroy splashes of food and fats when the oven temperature is raised to around 220°C.

To aid this process it is a good idea to run the oven for an hour or two per week, without food, to ensure continued good performance from the Catalytic liners.

i Hints and Tips

- Manual cleaning of the Catalytic liner is not recommended. Damage will occur if soap impregnated steel wool pads, aerosol cleaners and any other abrasives are used.
- Slight discolouration and polishing of the Catalytic surface may occur in time. This does not affect the Catalytic properties in any way.
- Follow the recommendations in “Cooking to reduce soilage”.

Cooking to reduce soilage

Cook at the recommended temperatures. Higher temperatures during roasting will increase soilage. Try

cooking to lower temperatures for an increased length of time, you will save energy and often the joint is more tender. Use minimal, if any, extra oil or fat when roasting meat; potatoes only require brushing with fat before cooking. Extra fat in the oven during roasting will increase splashing and soilage. It is NOT necessary to add water to the meat tin when roasting. The water and the fat juices from the joint create excessive splattering during cooking, even at normal temperatures, as well as causing condensation. Covering joints during cooking will also prevent splashing onto the interior surfaces; removing the covering for the last 20-30 minutes will allow extra browning, if required. Some large joints and turkeys especially benefit by this method of cooking, allowing the joint to cook through before the outside is overbrowned.

Do use the roasting tin. During roasting, the fat from the joint will be contained beneath the trivet and therefore prevent it from splattering onto the 'Catalytic' liner.

Something not working

If the oven is not working correctly, please carry out the following checks, before contacting your local Service Centre. **IMPORTANT:** If you call out an engineer to a fault listed below, or to repair a fault caused by incorrect use or installation, a charge will be made even if the appliance is under guarantee.

SYMPTOM	SOLUTION
<ul style="list-style-type: none"> ■ The oven does not come on 	<ul style="list-style-type: none"> ◆ Check that the current time of day has been set on the programmer (see chapter "Setting the time of day") ◆ Check that both a cooking function and temperature have been selected. ◆ Check the oven is wired in properly, and the socket switch or the switch from the mains supply to the oven are ON.
<ul style="list-style-type: none"> ■ The oven temperature light does not come on 	<ul style="list-style-type: none"> ◆ Select a temperature with the thermostat control knob ◆ Select a function with the oven function control knob.
<ul style="list-style-type: none"> ■ The oven light does not come on 	<ul style="list-style-type: none"> ◆ Select a function with the oven function control knob ◆ Check the light bulb, and replace it if necessary (see "Replacing the Oven Light")
<ul style="list-style-type: none"> ■ It takes too long to finish the dishes, or they are cooked too fast. 	<ul style="list-style-type: none"> ◆ The temperature may need adjusting ◆ Refer to the contents of this booklet, especially to the chapter "Using the Oven".
<ul style="list-style-type: none"> ■ Steam and condensation settle on the food and the oven cavity. 	<ul style="list-style-type: none"> ◆ Leave dishes inside the oven no longer than 15-20 minutes after the cooking is completed.
<ul style="list-style-type: none"> ■ The electronic programmer does not work 	<ul style="list-style-type: none"> ◆ Check the instructions for the timer.
<ul style="list-style-type: none"> ■ The oven fan is noisy 	<ul style="list-style-type: none"> ◆ Check that shelves and bakeware are not vibrating in contact with the oven back panel.

Service and Spare Parts

SERVICE FORCE

In the event of your appliance requiring service, or if you wish to purchase spare parts, please contact your local Zanussi Service Force Centre by telephoning:

0870 5 929929

Your telephone call will be automatically routed to the Service Force Centre covering your post code area.

For the address of your local Service Force Centre and further information about Service Force, please visit the website at www.serviceforce.co.uk

Before calling out an engineer, please ensure you have read the details under the heading "Something Not Working."

When you contact the Service Force Centre you will need to give the following details:

1. Your name, address and post code
2. Your telephone number
3. Clear and concise details of the fault
4. The model and serial number of the appliance (found on the rating plate)
5. The purchase date

Customer Care Department

For general enquiries concerning your Zanussi appliance or for further information on Zanussi products, please contact our Customer Care Department by letter or telephone at the address below or visit our website at www.zanussi.co.uk

Customer Care Department

Zanussi
55-77 High Street
Slough
Berkshire
SL1 1DZ
08705 727727 (*)

* calls to this number may be recorded for training purposes.

For Customer Service in the Republic of Ireland please contact us at the address below:

ZANUSSI
Electrolux Group (Ire) Ltd.
Long Mile Road
Dublin 12
Republic of Ireland

Tel: + 353 (0) 1 4090751
e-mail: service.eid@electrolux.ie

Guarantee Conditions

Zanussi Guarantee conditions

We, Zanussi, undertake that if, within 24 months of the date of the purchase, this Zanussi appliance or any part thereof is proved to be defective by any reason only of faulty workmanship or materials, we will, at our option, repair or replace the same **FREE OF ANY CHARGE** for labour, materials or carriage on condition that:

- * The appliance has been correctly installed and used only on the gas and electricity supply stated on the rating plate.
- * The appliance has been used for normal domestic purpose only, and in accordance with the manufacturer's instructions.
- * The appliance has not been serviced, maintained, repaired, taken apart or tampered with by any person not authorised by us.
- * All service work under this guarantee must be undertaken by a Zanussi Service Centre.
- * Any appliance or defective part replaced shall become the Company's property.
- * This guarantee is in addition to your statutory and other legal rights.

Home visits are made between **8.30am and 5.30pm** Monday to Friday. Visits may be available outside these hours, in which case a **premium** will be charged.

Exclusions

This guarantee does not cover:

- * Damage or calls resulting from transportation, improper use or neglect, the replacement of any light bulbs or removable parts of glass or plastic.
- * Costs incurred for calls to put right an appliance which is improperly installed or calls to appliance outside the United Kingdom.
- * Appliances found to be in use within a commercial or similar environment, plus those which are the subject to rental agreements.
- * Products of Zanussi manufacture which are not marketed by Zanussi.

European Guarantee

If you should move to another country within Europe then your guarantee moves with you to your new home subject to the following qualifications:

- * The guarantee starts from the date you first purchased your product.
- * The guarantee is for the same period and to the same extent for labour and parts as exist in the new country of use for this brand or range of products.
- * This guarantee relates to you and cannot be transferred to another user.
- * Your new home is within the European Community (EC) or European Free Trade Area.
- * The product is installed and used in accordance with our instructions and is only used domestically, i.e. a normal household
- * The product is installed taking into account regulations in your new country.

Before you move, please contact your nearest Customer Care centre, listed below, to give them details of your new home. They will then ensure that the local Service Organisation is aware of your move and able to look after you and your appliances.

France	Senlis	+33 (0)3 44 62 29 99
Germany	Nürnberg	+49 (0)911 323 2600
Italy	Pordenone	+39 (0)1678 47053
Sweden	Stockholm	+46 (0)8 738 79 50
UK	Slough	+44 (0)1753 219897

Installation

 *The oven must be installed according to the instructions supplied.*

 *This oven must be installed by **qualified personnel** to the relevant British Standards.*

Technical Data

Dimensions of recess

Height	undertop: 593 mm; in column	580 mm
Width		560 mm
Depth		550 mm

Dimensions of the oven cavity

Height		335 mm
Width		395 mm
Depth		400 mm
Oven capacity		53 litres

Heating elements rating

Inner Grill element	1,650 W
Full Grill element	2,450 W
Thermal Grilling	2,480 W
Convection element	2,000 W
Oven Light	25 W
Cooling Fan	25 W
Convection Fan	25 W
Total Rating	2,500 W
Supply voltage (50 Hz)	230 V

Electrical Connection

The oven is designed to be connected to 230 V (50 Hz) electricity supply.

The oven has an easily accessible terminal block which is marked as follows:

- Letter L - Live terminal
- Letter N - Neutral terminal
-  or E - Earth terminal

 **THIS OVEN MUST BE EARTHED**

The cable used to connect the oven to the electrical supply must comply to the specifications given below.

For Uk use only

Connection via	Min. size Cable/flex	Cable / flex type	Fuse
<ul style="list-style-type: none"> • 13 A socket outlet • 13 A spur box 	2.5 mm ²	3 core butyl insulated	13 A min.
<ul style="list-style-type: none"> • Cooker Control Circuit 	2.5 mm ²	PVC/PVC twin and earth	15 A min. 20 A max.

For Europe use only

Min. size Cable/flex	Cable / flex type	Fuse
1.5 mm ²	H07 RN-F, H05 RN-F, H05 RR-F, H05 VV-F, H05 V2V2-F (T90), H05 BB-F	13 A

It is necessary that you install a double pole switch between the oven and the electricity supply (mains), with a minimum gap of 3mm between the switch contacts and of a type suitable for the required load in compliance with the current rules.

The switch must not break the yellow and green earth cable at any point.

Important

After installation and connecting, the cable must be placed so that it cannot at any point reach a temperature of more than 50 °C above the ambient temperature.

Before the oven is connected, check that the main fuse and the domestic installation can support the load; and that the power supply is properly earthed.

The manufacturer disclaims any responsibility should these safety measures not be carried out.

Building In

Please ensure that when the oven is installed it is easily accessible for the engineer in the event of a breakdown.

Building In

The surround or cabinet into which the oven will be built must comply with these specifications:

- the dimensions must be as shown in the relevant diagrams;
- the materials must withstand a temperature increase of at least 60 °C above ambient;
- proper arrangements must be made of a continuous supply of air to the oven to prevent the oven overheating.

Dimensions of the oven and recess required are given in the relevant diagrams.

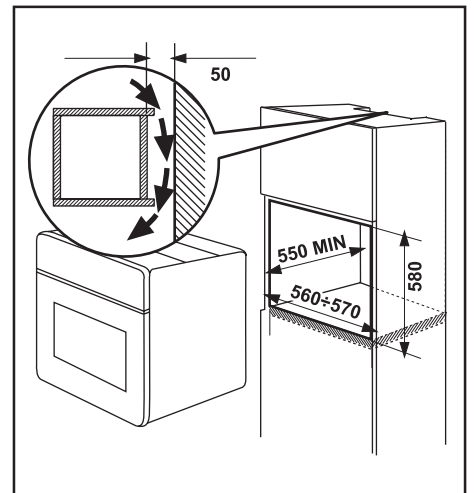
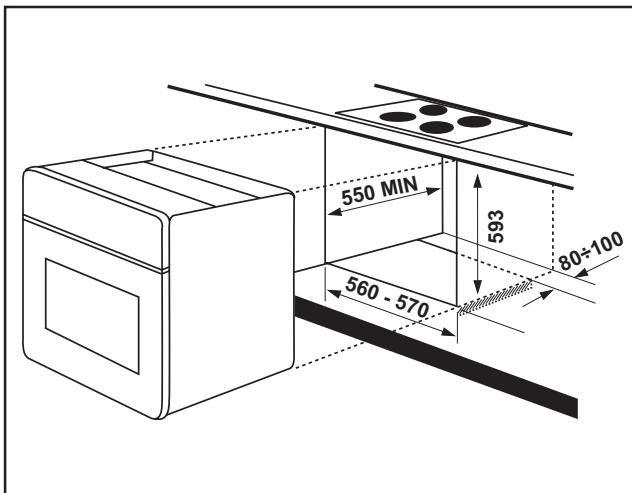
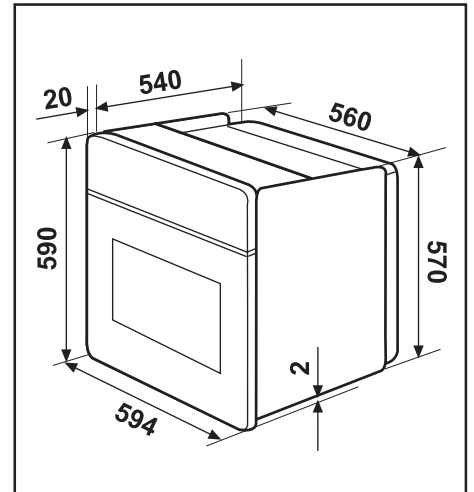

Securing The Oven To The Cabinet

1. Fit the oven into the cabinet recess,
2. Open the oven door,
3. Secure the oven to the kitchen cabinet with four wood screws, which fit the holes provided in the oven frame.

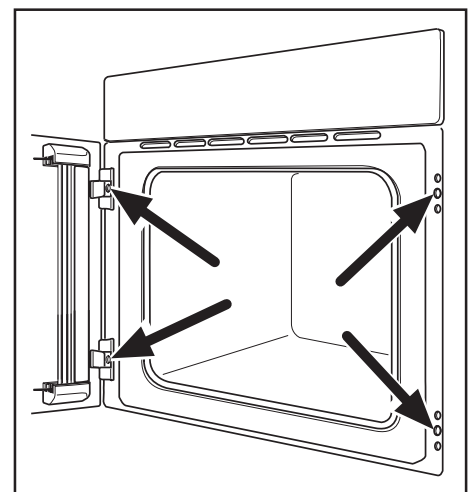

-	ES	DA	DE	EL	EN	FR	IT	NL	PT	SV	FI	
1	Fabricante	Mærke	Hersteller	Προμηθευτής	Manufacturer	Fabricant	Costruttore	Fabrikant	Fabricante	Leverantör	Tavarantoimittaja	ZANUSSI
2	Modelo	Model	Modell	Μοντέλο	Model	Modèle	Modello	Model	Modelo	Modell	Malli	ZBF 569
3	Clase de eficiencia energética	Relativt energiforbrug	Energieeffizienzklasse	Τύξη ενεργειακής απόδοσης	Energy efficiency class	Classement selon son efficacité énergétique	Classe di efficienza energetica	Energie-efficiëntieklasse	Classe de eficiência energética	Energieeffektivitetsklass	Energiatohokkuusluokka	
4	- Calentamiento convencional	- Traditionel opvarmning	- Konventionelle Beheizung	- Συμβατική	- Conventional	- Classique	- Convezione naturale	- Conventioneel	- Conveccional	- Konventionell värmning	- Ylä-alalämpö	
5	- Convección forzada	- Varmluft	- Um/Heißluft	- Με κυκλοφορία θερμού αέρα	- Forced air convection	- Convection forcée	- Convezione forzata	- Geforceerde luchtconvectorie	- Conveccão forçada de ar	- Värmning med varmluft	- Kiertolima	
	Consumo de energía Función de calentamiento:	Energiforbrug Opvarmningsfunktion:	Energieverbrauch Beheizung:	Κατανάλωση ενέργειας Λειτουργία θέρμανσης	Energy consumption Heating function:	Consommation d'énergie Fonction chauffage:	Consumo di energia Funzione di riscaldamento:	Energieverbruik luchtconvectorie-functie:	Consumo de energia Função de aquecimento:	Energiförbrukning Värmningsfunktion:	Energiankulutus Kuunnennustapa:	
6	- Calentamiento convencional	- Traditionel opvarmning	- Konventionelle Beheizung	- Συμβατική	- Conventional	- Classique	- Convezione naturale	- Conventioneel	- Conveccional	- Konventionell värmning	- Ylä-alalämpö	0,79 kWh
7	- Convección forzada	- Varmluft	- Um/Heißluft	- Με κυκλοφορία θερμού αέρα	- Forced air convection	- Convection forcée	- Convezione forzata	- Geforceerde luchtconvectorie	- Conveccão forçada de ar	- Värmning med varmluft	- Kiertolima	0,78 kWh
8	- Vapor	- Dampf	- Dampf	- Ατμός	- Steam	- Vapeur	- Vapore	- Stoom	- Vapor	- Ånga	- Höyry	
9	Volumen neto (litros)	Nettovolumen (liter)	Nettovolumen (Liter)	Ωφέλιμος όγκος (λίτρα)	Usable volume (litres)	Volume utile (litres)	Volume utile (litri)	Netto volume (liter)	Volume útil Litros	Användbar volym (liter)	Käyttötilavuus (litraa)	53
	Tipo: ● Pequeño ● Medio ● Grande	Type: - Lille - Mellemstort - Stort	Typ: - Klein - Mittel - Groß	Τύπος: - Μικρός - Μέσσιος - Μεγάλος	Size: - Small - Medium - Large	Type: - Faible volume - Volume moyen - Grand volume	Tipo: - Piccolo - Medio - Grande	Type: - Middelgroot - Groot	Tipo - pequeno - medio - grande	Storlek: - Liten - Medelstor - Stor	Koko: - Pieni - Kesikokoinen - Suuri	
	Tiempo de cocción con carga normal:	Tilberedningstid ved standardbelastning:	Kochzeit bei Standardbelastung:	Χρόνος για ψησίσιμο τυποποιημένου φορτίου:	Time to cook standard load:	Temps de cuisson en charge normale:	Tempo necessario per cottura carico normale:	Bereidings-tijd bij standaardbelasting:	Tempo de cozedura da carga-padrão:	Tillagningstid för en standardlast:	Paistaaika vakiokuormalla:	
10	- Calentamiento convencional	- Traditionel opvarmning	- Konventionelle Beheizung	- Συμβατική	- Conventional	- Classique	- Convezione naturale	- Conventioneel	- Conveccional	- Konventionell värmning	- Ylä-alalämpö	43 min.
11	- Convección forzada	- Varmluft	- Um/Heißluft	- Με κυκλοφορία θερμού αέρα	- Forced air convection	- Convection forcée	- Convezione forzata	- Geforceerde luchtconvectorie	- Conveccão forçada de ar	- Värmning med varmluft	- Kiertolima	41 min.
12	Superficie de la placa de cocción de mayor tamaño	Arealet af den største bageplade	Größe des größten Backblechs	Η μεγαλύτερη επιφάνεια ψησίματος εκροσζόεινη	The area of the largest baking sheet	Aire de la surface de la plus grande plaque pour pâtisserie	Superficie del piano di cottura più grande	Oppervlakte van de grootste bakplaat	Área da superfície da maior placa de pastelaria	Ytan för den största bakplåten	Suurimman leivinpellin ala	1130 cm ²
13	Ruido [dB (A) re 1 pW]	Lydeffekt-niveau dB (A) (Støj)	Geräusch (dB (A) re 1 pW)	Ξόρυβος [dB (A) ανά 1 pW]	Noise (dB (A) re 1 pW)	Bruit [dB (A) re 1 pW]	Rumore [dB (A) re 1 pW]	Getuidsniveau dB (A) re 1 pW	Nível de ruído dB (A) re 1 pW	Bullernivå dB (A)	Ääni (dB (A) re 1 pW)	
	<ul style="list-style-type: none"> ● Más eficiente ● Levit forbrug ● Niedriger Verbrauch ● Πιο αποδοτικό ● More efficient ● Économie 	<ul style="list-style-type: none"> ● Bassi consumi ● Lavt forbrug ● Effizient ● Mais efficace ● Låg förbrukning ● Vähän kuluttava 	<ul style="list-style-type: none"> ● Geringer Verbrauch ● Effizient ● Plus économique ● Menos consumo ● Menos eficiente ● Hög förbrukning ● Pajon kuluttava 	<ul style="list-style-type: none"> ● Menos eficiente ● Høj forbrug ● Hoher Verbrauch ● Αποδοτικό ● Less efficient ● Peu économe 	<ul style="list-style-type: none"> ● Alti consumi ● Inefficient ● Menos eficiente ● Hög förbrukning ● Pajon kuluttava 	<ul style="list-style-type: none"> ● 12 l ≤ Volumen neto/Nettovolumen/Ωφέλιμος όγκος/Usable volume/Volume utile/ Netto volume/Volume útil/Användbar volym/Käyttötilavuus < 35 l ● 35 l ≤ Volumen neto/Nettovolumen/Ωφέλιμος όγκος/Usable volume/Volume utile/ Netto volume/Volume útil/Användbar volym/Käyttötilavuus < 65 l ● 65 l ≤ Volumen neto/Nettovolumen/Ωφέλιμος όγκος/Usable volume/Volume utile/ Netto volume/Volume útil/Användbar volym/Käyttötilavuus 	2002/40/EC					

CUSTOMER CARE

Zanussi

55-77 High Street
Slough
Berkshire, SL1 1DZ
Tel: 08705 727727

© Electrolux plc 2003

 **From the Electrolux Group. The world's No.1 choice.**

The Electrolux Group is the world's largest producer of powered appliances for kitchen, cleaning and outdoor use. More than 55 million Electrolux Group products (such as refrigerators, cookers, washing machines, vacuum cleaners, chain saws and lawn mowers) are sold each year to a value of approx. USD 14 billion in more than 150 countries around the world.