

ZANUSSI

**Instructions
for the use and care
of FM 15
built-in double oven**

It is most important that this instruction book should be retained with the appliance for future reference. Should the appliance be sold or transferred to another owner, or should you move house and leave the appliance, always ensure that the book is supplied with the appliance in order that the new owner can be acquainted with the functioning of the appliance and the relevant warnings.

Warnings – Built-in ovens

THESE WARNINGS ARE PROVIDED IN THE INTEREST OF SAFETY. YOU MUST READ THEM CAREFULLY BEFORE INSTALLING OR USING THE APPLIANCE.

- **This appliance is designed to be operated by adults. Children should not be allowed to tamper with the controls or play with the product.**
- **Any installation work must be undertaken by a qualified electrician or competent person.**
- **It is dangerous to alter the specifications or modify the product in any way.**
- **This appliance should be serviced by an authorised Zanussi Network Service Centre, and only genuine Zanussi spare parts should be used.**
- **Cookers can become very hot with use, and retain their heat for a long period of time after use: Children should be supervised at all times and should not be allowed to touch the hot surfaces or be in the vicinity when in use or until the appliance has cooled after use.**
- **Always ensure that the control knobs are in the «off» position when not in use.**
- **For hygiene and safety reasons, this appliance should be kept clean at all times. A build-up of fats or foodstuffs could result in a fire.**
- **This appliance has been designed for cooking edible foodstuffs only, and must not be used for any other purposes.**
- **Never line any part of the oven with aluminium foil.**
- **Easy clean liners should never be cleaned with any other than soapy water (see cleaning instructions).**
- **Before any maintenance or cleaning work is carried out on the appliance, always turn off the isolator switch at the cooker point, and allow to cool.**
- **Ensure that the anti-tip oven shelves are put in place in the correct way (see instructions).**
- **Under no circumstances should you attempt to repair the appliance yourself. Repairs carried out by inexperienced persons may cause injury or more serious malfunctioning. Refer to your local Zanussi Service Centre. Always insist on genuine Zanussi spare parts.**

Contents

Building-in	page 3
Connecting to electricity	page 5
Use and Care	page 6
Using the upper oven	page 8
Using the lower oven	page 11
Using the grill	page 11
Cleaning	page 13
What happens if something goes wrong	page 15

Important: the installation of the oven and connecting it to electricity must always be done by competent installers and to standards and regulations currently in force.

Building-in

It is important that the dimensions and materials of the surround or cabinet into which the oven will be built are correct and that proper arrangements are made for a continuous supply of air to the oven so it does not overheat.

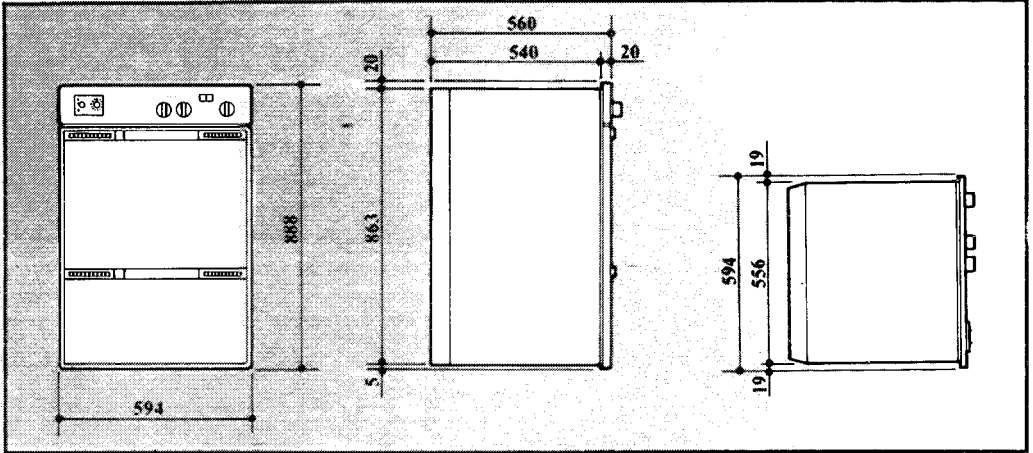

Fig. 1

Dimensions of the recess for building into a kitchen unit (mm).

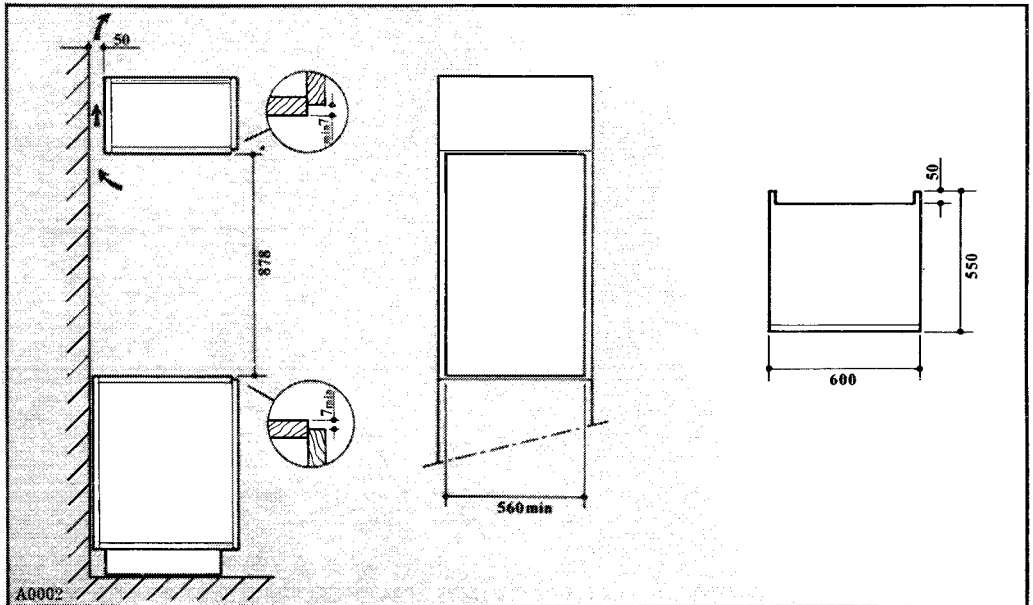

Fig. 2

Important

To ensure an efficient ventilation, it is necessary to leave the vents provided at the bottom of the oven clear.

Securing the oven to the cabinet

Fit the appliance into the cabinet recess. Open the oven door and secure the oven to the kitchen cabinet with six wood screws which fit exactly the holes provided in the oven frame (Fig. 3).

Cooling fan

The cooling fan is designed to cool the oven housing and the components of the oven itself.

The fan switches on automatically when either of the oven control knobs are turned on.

Cool air is drawn in through the vents at the bottom of the oven to cool the oven and housing by absorbing the residual heat. This warm air is then blown out through the venting grille incorporated in the upper oven door handle mechanism.

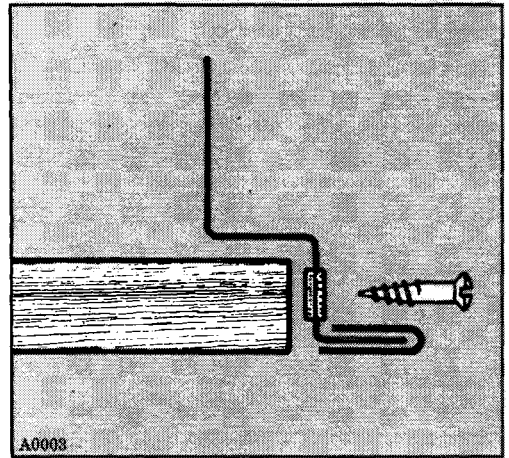

Fig. 3

Connecting to electricity

The oven is designed to be connected to 240V - 50 Hz electricity supply.

The upper oven has a heating element rated at 2500W.

The lower oven ratings are as follows:

Lower element	1000 W
Upper element	1000 W
Grill element	2000 W

The oven has an easily accessible terminal block which is marked as follows:

Letter L	Live terminal
Letter N	Neutral terminal
	Earth

The cable used must be of the three core type with a min. cross section of 2.5 mm². In order to connect it to the oven it is necessary to remove the hatch at the back of the oven to reach the terminal block.

For direct connection to the mains supply a two pole switch with a minimum rating of 19 A and a minimum distance of 3 mm between its contacts must be fitted between the supply and the appliance.

This switch must not break the yellow/green earth cable at any point.

The appliance must be earthed.

Important

After installation and connecting, the cable must be placed so that it cannot at any point reach a temperature more than 50°C above the ambient temperature.

Before the appliance is connected check that:

the main fuse and the domestic installation can support the load;
the power supply is properly earthed;

the double pole switch used to connect the appliance to the supply is easily accessible after installation.

The manufacturers disclaim any responsibility should these safety instructions not be carried out.

This appliance meets the requirements laid down in EEC Directive No 82/499 dated 7-6-82 relating to the suppression of radio and TV interference.

Use and care

When the appliance is first installed

Once the appliance is installed the protective materials which were put on in the factory must be removed.

The plastic film covering some external parts can be removed by wiping with a cloth dipped in methylated spirit.

Other protective materials will burn off if the controls of the ovens are turned to MAX and then it is allowed to run empty for 30 minutes.

This will also remove any unpleasant smells.

The FM 15 consists of two ovens.

The upper oven is evenly heated throughout. A fan in the back wall distributes heated air round the food during cooking so that everything cooks in the same time regardless of where it is placed in the oven or how much is being cooked.

Foods of different types, provided they require the same cooking temperature, can be cooked together and there is no possibility of any flavours or smells being transmitted from one food to another.

This is the Zanussi cuisinair system.

Cooking can be manual or automatic (with or without the programmer).

The programmer includes a digital clock, a minute minder and controls by which the upper oven can be set to come on and go off unattended.

The lower oven is a conventional one and contains a grill.

The grill control provides a variety of heat settings.

The dials above each control knob show when the oven is switched on, whilst the indicator lights shown the behaviour of the thermostat during cooking.

A light comes on inside the oven when it is switched on and remains on until the oven goes off.

The internal dimensions are:

	Top oven	Bottom oven
Height	320 mm	185 mm
Width	420 mm	420 mm
Depth	390 mm	400 mm
Capacity	53,0 litres	31 litres

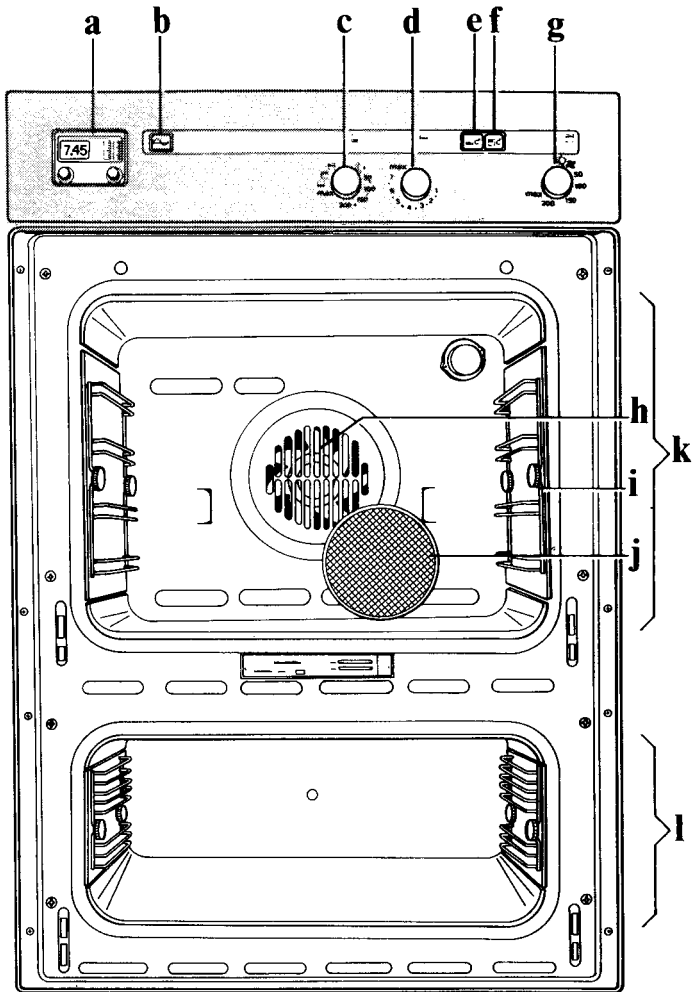

- | | |
|--------------------------------|---------------------------|
| a Electric programmer | g Upper oven control knob |
| b ON/OFF light | h Fan |
| c Lower oven control knob | i Removable shelf runners |
| d Grill control knob | j Removable grease filter |
| e Lower oven temperature light | k Upper oven |
| f Upper oven temperature light | l Lower oven |

Fig. 4

Using the upper oven

As soon as the oven is switched on the fan starts and runs until the oven control is switched off again (Fig. 5).

The food should be put into the oven before switching on, even when cooking manually - the speed of heating up is so fast that there is no need to preheat.

The oven shelves can be fully filled. Most normal types and materials of cooking utensils can be used.

During cooking the door should be opened as little as possible to avoid heat loss and so excessive electricity consumption.

Cooking manually

When cooking manually ensure that the programmer is not in operation accidentally.

If this is not the case and you do not want to use the automatic programmer, return the control to the manual position. Arrange the food in the oven, shut the door and turn the oven control (Fig. 5) to the required temperature setting.

When the control reaches ⌘ the oven temperature light will come on, also an internal oven light.

This setting is NOT a cooking position but is intended for rapid thawing of frozen food.

Positions from 50°C to MAX are cooking positions and give a full range of temperatures.

The oven temperature light will come on until the oven has reached the correct temperature; after that it will come on and off showing how the temperature is being maintained.

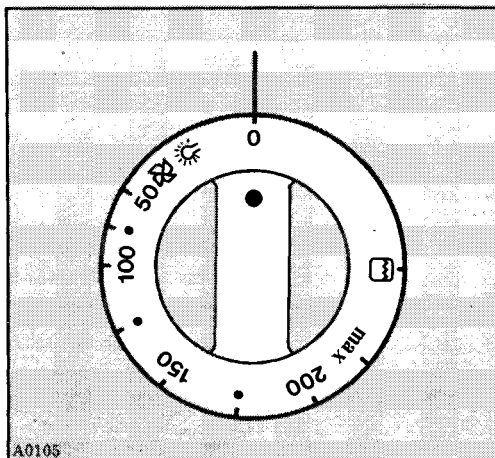

A0105

Fig. 5

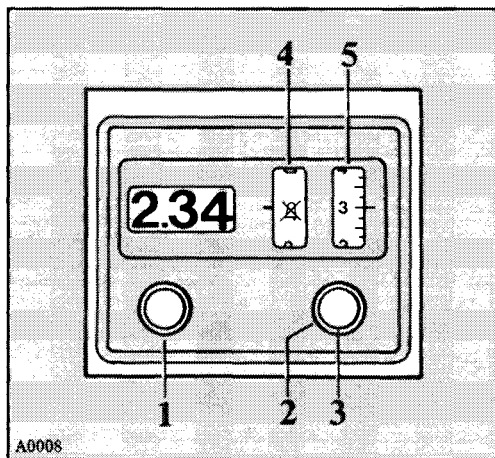

A0008

Fig. 6

Cooking automatically

The upper oven cooks automatically when the programmer is set to switch it on and off at the times given without the need for anyone to be in attendance. Most foods cook well automatically but preference should be given to those which will not be affected by the waiting period before the oven comes on.

The digital electric programmer

The electric programmer has the purpose of turning on the cooker automatically at the preset time and to turn it off automatically when the cooking time is up.

Furthermore, it also features an electric clock, showing the hour of the day and a minute minder with electric bell.

Operation of the electric programmer

Fig. 6 shows the controls of the electric programmer.

By means of knobs 1, 2 and 3, all necessary adjustments can be carried out i.e.:

Knob 1

By turning this knob clockwise, you can reset the digital clock to the correct time (for instance upon installation or following a power failure, or when the clock is fast or slow, etc.).

Knob 2

By turning it clockwise, this knob will set the following controls on dial 4 (Fig. 6):

the required cooking time (up to 210 mins.);

the «crossed bell»  symbol to interrupt the sound signal;

the «open hand»  symbol permits manual operation of the oven.

Knob 3

By pressing it in and turning it either clockwise or anticlockwise, this knob allows you to set on dial 5 (Fig. 6) the cooking start time.

When resetting the clock make sure that the time shown by dial 5 coincides with the time shown by the clock itself.

Attention

The cooking of dishes with the oven preset for «manual operation» is possible only **if the time of the day shown by the electric clock is synchronized with the time shown on dial «5».**

Therefore, when the oven is started for the first time, during time corrections due to the clock being fast or slow, or whenever a fully automatic cooking process is interrupted, it will be necessary to check and - if need be - restore such synchronization.

The programmable electric clock is synchronized when it is possible to turn on the oven inner light.

Manual operation of the upper oven

The oven may also be operated manually, i.e. with the programming device not actuated. In this case, turn knob 2 of the programming device clockwise until the «open hand»  symbol coincides with the index of dial 4.

Semiautomatic operation of the upper oven

This oven makes it possible to either finish or start cooking automatically, both in the oven itself and with the grill.

1st instance:

manual cooking start
- programmed, i.e.
automatic
cooking stop.

Place the food to be cooked into the oven;

Turn knob 2 clockwise, and set on dial 4 the number of minutes corresponding to the required cooking end;

Turn the oven knob to the required temperature setting.

2nd instance:

programmed, i.e.
automatic cooking
start - manual
cooking stop.

Place the food to be cooked into the oven.

Press in and turn knob 3 clockwise setting on dial 5 the required cooking start time;

Turn knob 2 clockwise, setting on dial 4 the maximum time allowed by the programmer (210 mins.);

Turn the oven knob to the required temperature setting.

Important

To stop the automatic cooking, turn knob 2 clockwise, setting on dial 4 the symbol «0» to switch off the oven; then turn the same knob 2 to the «crossed bell»  symbol to stop the sound signal.

If the cooking stop time is to be set manually, turn knob 2 clockwise until the «open hand»  symbol is centered on dial 4.

Totally automatic operation of the upper oven

Place the food to be cooked in the oven;

Turn knob 2 clockwise and set on dial 4 the required cooking duration;

Press in and turn clockwise knob 3, setting on dial 5 the cooking start time;

Turn the oven control knob to the desired temperature level.

When the cooking time is up, symbol «0» will coincide with the index of dial 4.

This indicated that the oven is disconnected from the electric supply, and at this point a sound signal will indicate that the cooking is over.

To stop the sound signal, turn knob 2 clockwise until the «crossed bell»  symbol coincides with the index of dial 4.

Example of programmer setting for automatic operation of the oven

Cooking stop time: 19.00 hours

Cooking duration: 2 hours

Place the food to be cooked into the oven;

Turn knob 2 clockwise, setting on dial 4 the required cooking duration, (i.e. «2 HOURS»);

Press in and turn knob 3 clockwise, setting on dial 5 the cooking start time, i.e.: 5 p.m. (corresponding to 17.00 hours);

Turn the oven control knob to the required temperature setting.

After carrying out the above settings, the oven will operate automatically from 17.00 hours to 19.00 hours.

Minute minder

The programmer will act as a minute minder only if no automatic cooking is programmed and the oven is not turned on.

To operate the minute minder, turn knob 2 clockwise and set on dial 4 the required cooking time.

The maximum allowed cooking duration is 210 mins.

To stop the sound signal, turn knob 2 clockwise until the «crossed bell»

 symbol coincides with the index of dial 4.

Programmed cookings

Programmed cookings do not differ from normal cookings.

The programmer controls the cooking time selected while you are absent or are doing something else.

Therefore, for totally automatic cooking, foods not requiring particular care should be preferred.

The programming of a cooking time exceeding the 12-day hours (i.g. 20.00 hours have to be understood as 8.00 hours and so on).



Therefore, it is possible to programme the cookings 12 hours in advance.

Using the lower oven

Preheat the oven, arrange the food in the oven, shut the door and turn the oven control (Fig. 7) to the required temperature setting. When the control reaches  the oven temperature light will come on, also the internal oven light which will remain on during the whole cooking time.

Position from 50°C to MAX are cooking positions and give a full range of temperatures.

The oven temperature light will come on until the oven has reached the correct temperature, after which it will go on and off showing how the temperature is being maintained.

When the oven control reaches  the bottom element comes on and a max. temperature of 240°C can be obtained. When the oven control reaches , the top element comes on and a max. temperature of 300°C can be obtained. These settings are particularly useful for finishing food either only on the top or the bottom.

During cooking, the door should be opened as little as possible to avoid heat loss and so excessive electricity consumption.

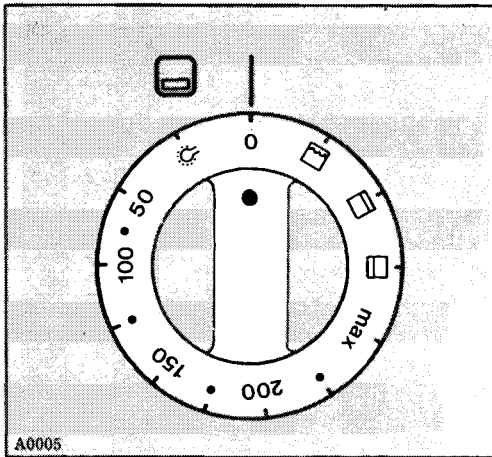

Fig. 7

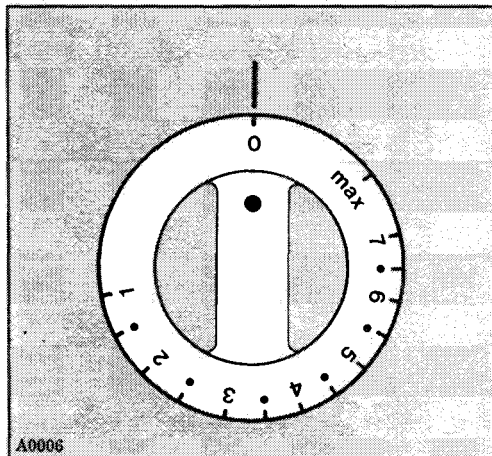

Fig. 8

Using the grill

The grill is located in the lower oven. As with the ovens, the grill control can be set to a number of different heats (Fig. 8).

At MAX the element stays on continuously to give the highest degree of heat.

Foods to be grilled are placed on the wire grid in the grill pan which can be curved either upwards or downwards to give the required distance from the element.

The pan is then placed in the required runner position.

Important

Because the grill element is in the top of the lower oven, the door must be left ajar when grilling.

This means that the escaping heat from the grill could overheat the upper oven door and the control panel, so to prevent this happening it is essential that the heat deflector provided to protect the rest of the appliance is in place before the grill is switched on.

The deflector is put in place as shown in Fig. 9.

To use the grill

Open the door and put the heat deflector in position.

Turn the oven control (see Fig. 7) to  and then set the grill control to the heat setting required.

When grilling is over remove the heat deflector and shut the door.

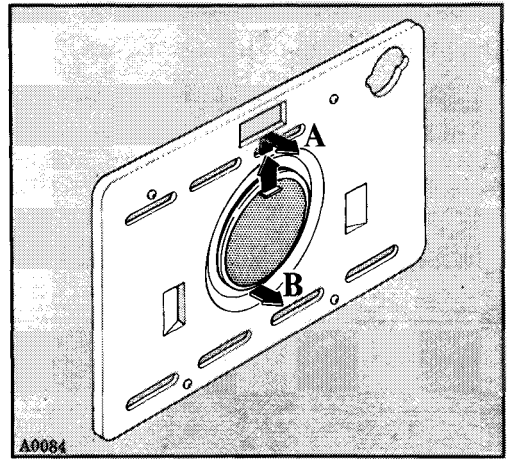

A0084

Fig. 10

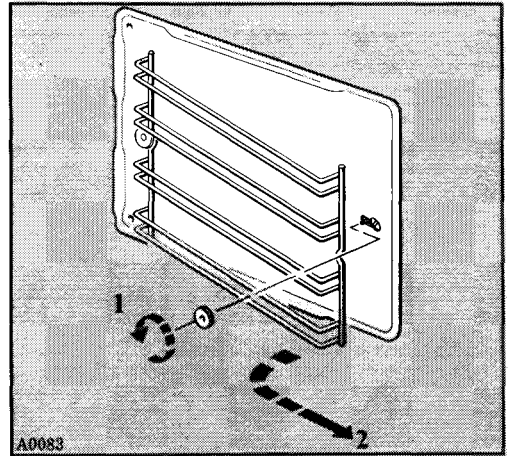

A0083

Fig. 11

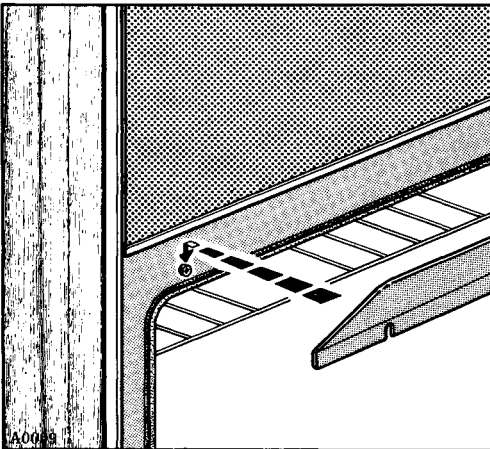

A0089

Fig. 9

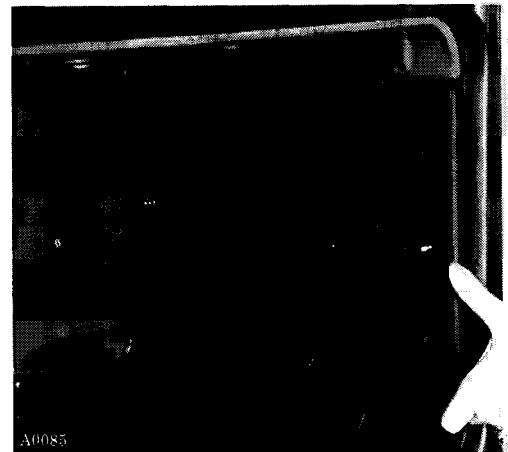

A0085

Fig. 12

Maintenance and cleaning

Important

The electricity supply must be switched off before undertaking any maintenance operation.

The oven will have a longer life if it is frequently cleaned thoroughly, paying special attention to the following:

The cleaning should not be carried out when the oven is still warm;

The enamelled parts should be cleaned with lukewarm water and soap without using abrasive scourers which may damage them;

The parts in stainless steel after their cleaning, are to be dried with chamois leather.

Never use abrasive scourers or steel wool, muriatic acid or other abrasive cleaners which may scratch the finish. The enamelled and glass parts should not be cleaned while they are still warm.

Grease filter (upper oven)

This filter protects the fan from fat splashes; it should always be cleaned after roasting has taken place.

As it is stainless steel you can safely wash it in a dishwasher.

Removing the grease filter (Fig. 10)

To remove the filter, proceed as follows:

filter type A: pull up the protruding tongue and then pull the filter outwards, removing it from the rear panel;

filter type B: insert a finger into the special groove of the filter, press down and then pull the filter outwards, removing it from the rear panel.

Removing and cleaning the oven panels (Supplied on request)

If you wish to remove lateral and upper panels proceed as follows:

Remove the upper panel; unscrew the fixing ring nuts of the side runners (Fig. 11);

Remove the runners and the panels (Fig. 12).

If necessary, you can also remove the back panel, but in this case you have also to disconnect the electricity supply.

Unscrew the panel fixing screws by means of a screwdriver (Fig. 13).

In order to protect the upper oven the appliance features an enamelled panel, suitably shaped, to contain possible liquid overflowings.

To make thorough cleaning of this panel easier, you can extract it from the bottom by pulling it up.

If you use an oven spray cleaner, be careful not to spray it on the oven fan and on the thermostat feeler.

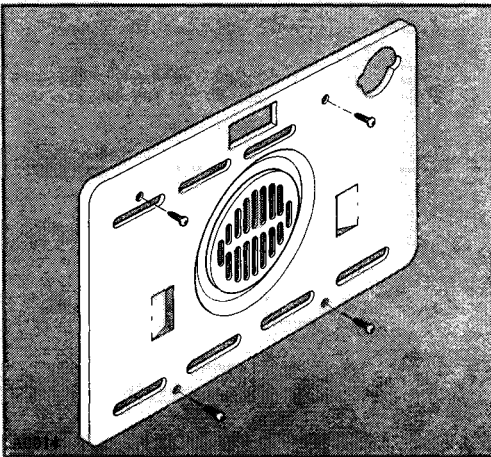

Fig. 13

Cleaning the lower oven

The oven interior is made of a strong vitreous enamel and therefore can be cleaned with any normal caustic oven cleaner.

Remove, by pulling out, the infrared grill (Fig. 14) and put the safety plug into the grill plug (Fig. 15).

Remove the side runners as described for the upper oven.

Important

Please take care to follow the oven cleaner manufacturer's instructions precisely.

Care must be taken to ensure that the oven cleaner does not come into contact with the aluminium and painted surfaces of the appliance.

Replacing appliance components

Prior to undertaking any maintenance work or replacing the oven lamp or grill heating element, be sure to disconnect the appliance from the electric supply.

1. Control Knobs

These can be removed by pulling them out.

2. Oven lamp replacement

Unscrew glasscap (Fig. 16) and replace burnt-out with one that resists to high temperatures (300°C).

Electric bulb: 15W, 240V-50Hz, 300°C, E14.

Removing the oven door

(Fig. 17/A - 17/B)

To thoroughly clean the oven you should remove the door by proceeding as follows:

1. With the aid of a coin, turn the oven door stops (catches) 45° to the right. See drawing A.

2. Raise the door to the limit stop and pull it out in a forward direction. See drawing B. Grasp the door on the two sides - don't pull it by the handle!

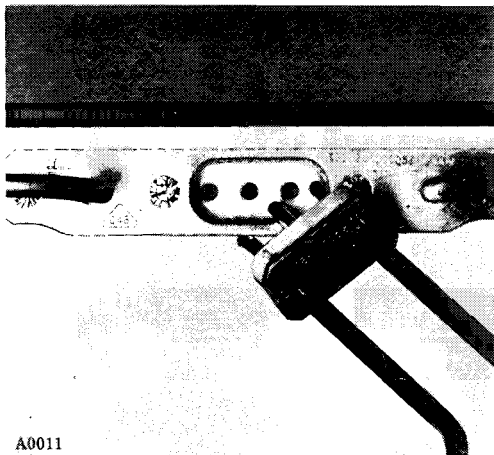

A0011

Fig. 14

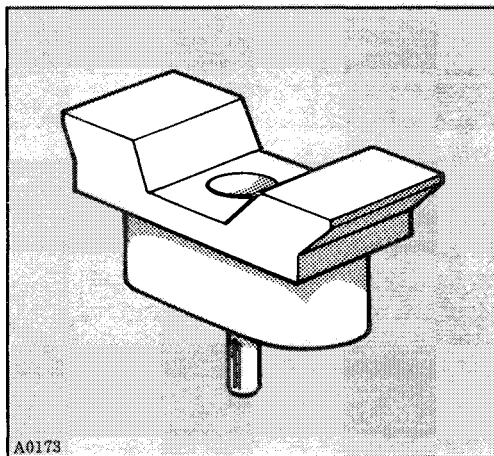

A0173

Fig. 15



A0128

Fig. 16

To re-install the door:

- . Insert the door into the oven with its two brackets.
- . Open the oven door and return the door stops (catches) to their original position.

What happens if something goes wrong

Important

If the ovens do not come on when cooking manually, first check that the fault is with both ovens - it may be that if it is the upper one only that is affected there is probably a simple answer - the programmer is set to automatic - to set it to manual turn the control knob to the required position. If this is not the answer then:

check that the appliance is connected correctly;

check that the switch from the supply to the appliance is ON;

replace the fuse in the socket, where present, with another of the appropriate rating;

check that the fuse in the fuse box is intact.

If after all these checks the appliance still does not work, call your local Zanussi Network service centre listed in the telephone directory.

It helps to jot down the address and telephone number in the space below.

Power cuts

Should the electricity supply fail for any reason remember to reset the programmer clock to the right time when the power is resumed.

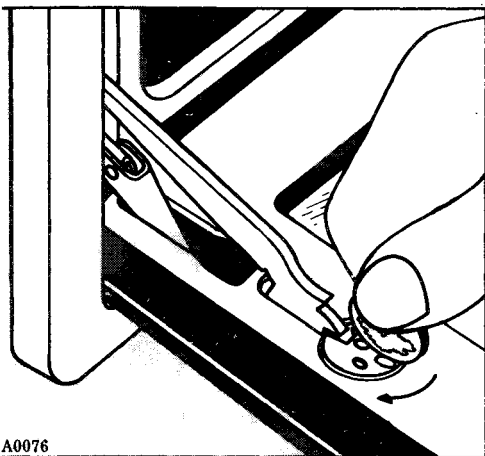

A0076

Fig. 17/A

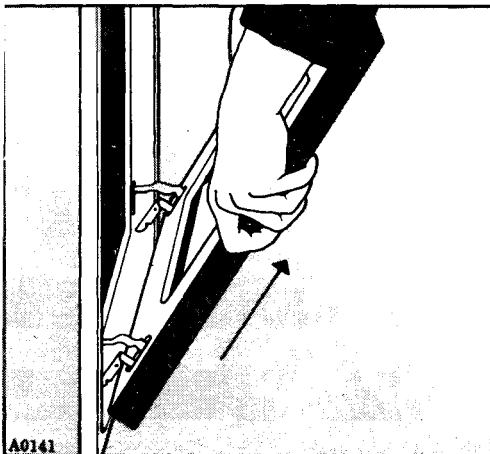

A0141

Fig. 17/B



ZANUSSI STANDARD GUARANTEE CONDITIONS

This guarantee is in addition to your statutory and other legal rights which will not be excluded or in any way diminished by the return of the guarantee card.

We, Zanussi Limited, undertake that if, within twelve months (24 months for TV sets) of the date of the purchase, this ZANUSSI appliance or any part thereof is proved to be defective by reason only of faulty workmanship or materials, we will, at our option, repair or replace the same **FREE OF ANY CHARGE** for labour, materials or carriage on condition that:

—The appliance has been correctly installed and used only on the electricity supply stated on the rating plate.

—The appliance has been used for normal domestic purposes only, and in accordance with the manufacturer's operating and maintenance instructions.

—The appliance has not been serviced, maintained, repaired, taken apart or tampered with by any person not authorised by us.

—The appliance is still in the possession of the original purchaser.

All service work under this guarantee must be undertaken by a Zanussi Network Service Centre (or the Zanussi Authorised TV Service Dealer).

Any appliance or defective part replaced shall become our property.

Exclusions

This guarantee does not cover:

—Damage or calls resulting from transportation, improper use or neglect, the replacement of any light bulbs or removable parts of glass or plastic.

—Costs incurred for calls to put right machines improperly installed or calls to machines outside the UK and the Republic of Ireland.

—Appliances found to be in use within a commercial environment, plus those which are the subject of rental agreements.

—Television receivers - routine adjustment, or poor reception resulting from a source outside of the receiver.



ZANUSSI 5 YEAR COVER CONDITIONS

For a once-only payment you can extend your Standard Guarantee to 5 years. All the conditions and exclusions of the Standard Guarantee apply.

Notes

1. Products supplied as "seconds", refurbished, damaged or shop-soiled are not eligible for Zanussi 5 year cover.
2. The issue of a cover does NOT by virtue of our having done so, nullify the exclusions.
3. The Engineer will need to check the details of your Cover card and may make a charge for his services if it is not presented to him at the time of his call.
4. The date of purchase, or the date of initial payment (deposit) of the appliance will be deemed the date of commencement of cover.
5. Covers issued are not refundable or transferable.

ZANUSSI
The appliance of science