

DR SERIES FORCED DRAFT 15# & 150#
STEAM BOILER (DR250-DR850) REVERSE CONSTRUCTION

EFFECTIVE DATE: 12/9/03
REPLACES: 10/29/03

NOTES:

1. ALL DIMENSIONS ARE IN INCHES THOSE IN PARENTHESES ARE CENTIMETERS.
2. LOCATION DIMENSIONS ARE ALL $\pm 1/2"$.
3. GAS TRAIN, CONTROL AND BURNER CONFIGURATION WILL VARY DEPENDING ON JOB SPECIFICATIONS & CONDITIONS.
4. DIMENSIONS ARE SUBJECT TO CHANGE WITHOUT NOTICE. CONSULT FACTORY FOR CERTIFIED DIMENSIONS.
5. ALL FLANGES ARE 150# UNLESS OTHERWISE NOTED, FLANGES TO STRADDLE CENTER LINE.

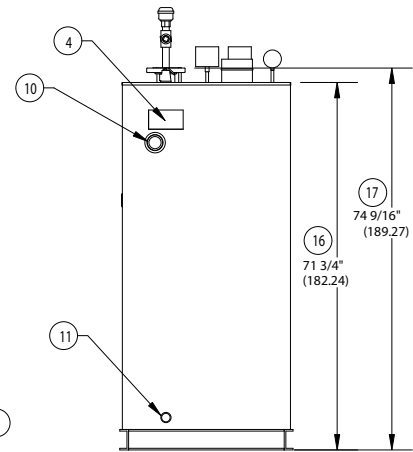
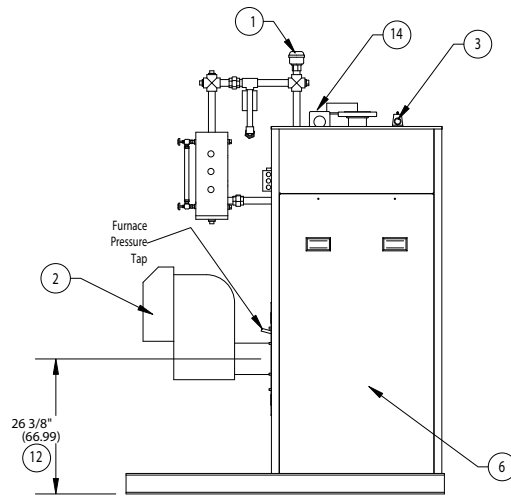
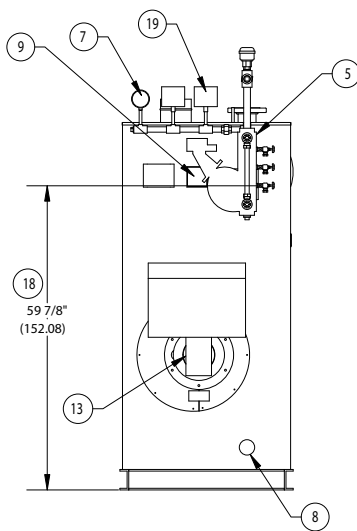
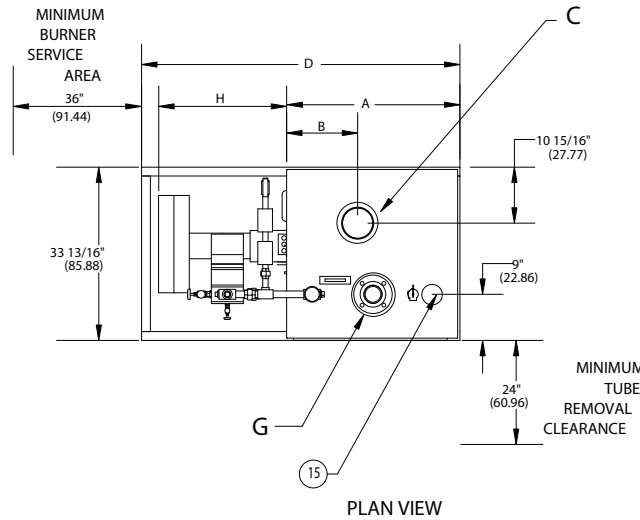

1. PROBE TYPE AUX. L.W.C.O.
2. FORCED DRAFT BURNER
3. RELIEF VALVE
4. ASME NAMEPLATE
5. LWCO/PUMP CONTROL - 157

6. JACKET ACCESS PANELS
7. PRESSURE GAUGE
8. CLNOUT./INSP. OPNG.-1 1/2"NPT
9. ELEC. ENCLOSURE -
10. CLNOUT./INSP. OPNG. - 2" NPT

11. DRAIN/ BLOWDOWN - 1" NPT
12. BURNER CENTER LINE
13. OIL PUMP LOCATION
14. LIFTING LUG
15. FEED CONNECTION 2" NPT

16. HEIGHT OVER JACKET
17. HEIGHT OVER SUPPLY
18. MINIMUM SAFE WATER LEVEL
19. PRESSURE CONTROLS

BOILER MODEL	DR250	DR350	DR450	DR650	DR850
A-LENGTH OVER JACKET	33 3/4" (85.72)	33 3/4" (85.72)	33 3/4" (85.72)	45 1/16" (114.45)	45 1/16" (114.45)
B-FLUE LOCATION	13 3/4" (34.92)	13 3/4" (34.92)	13 3/4" (34.92)	13 3/4" (34.92)	13 3/4" (34.92)
C-FLUE DIAMETER	6" (15.24)	6" (15.24)	6" (15.24)	8" (20.32)	8" (20.32)
D-LENGTH OVER BASE	62 1/8" (157.79)	62 1/8" (157.79)	62 1/8" (157.79)	73 1/2" (186.69)	73 1/2" (186.69)
G-SUPPLY NOZZLE SIZE	3" (7.62)	3" (7.62)	3" (7.62)	4" (10.16)	4" (10.16)
H-BURNER EXTENSION	CONSULT FACTORY FOR BURNER EXTENSION				



BRYAN BOILERS

783 NORTH CHILI AVE
PERU, INDIANA 46970

ORDER NO.:

ORDER REV. NO.:

FORM NO: 2178

**DR SERIES FORCED DRAFT
STEAM BOILERS REVERSE CONSTRUCTION**

BOILER MODEL		DR250	DR350	DR450	DR650	DR850
INPUT	MBH	250	350	450	650	850
	(KW)	73.2	102.5	131.8	190.4	249.0
OUTPUT	MBH	200	280	360	520	680
	(KW)	58.6	82.0	105.5	152.4	199.2
BOILER HORSEPOWER	HP	6	8	10	15	20
	(KW)	58.6	82.0	98.0	147.0	196.0
TUBE DIAMETER	INCHES	1.00	1.00	1.00	1.00	1.00
	(CM)	2.54	2.54	2.54	2.54	2.54
NUMBER OF TUBES		18	18	18	29	29
PRESSURE VESSEL						
VOLUME	GAL	31	31	31	45	45
	(L)	117.3	117.3	117.3	170.3	170.3
HEATING SURFACE	SQ FT	66	66	66	103	103
	(SQ M)	6.1	6.1	6.1	9.6	9.6
STEAM OUTPUT*						
	LBS/HR	206	288	371	536	701
	(KG/HR)	93.4	130.6	168.3	243.1	318.0
OPERATING WEIGHT	LBS	1,408	1,408	1,408	2,025	2,025
	(KG)	638.9	638.9	638.9	918.6	918.6
SHIPPING WEIGHT	LBS	1,150	1,150	1,150	1,650	1,650
	(KG)	521.6	521.6	521.6	748.4	748.4
RELIEF VALVE TYPICAL - 15 PSIG (103.4 KPA)						
QUANTITY		A v a i l a b l e	(1) 13-213-08	(1) 13-213-08	(1) 13-213-08	(1) 13-213-08
SIZE	INCHES		1-1/4 x 1-1/4	1-1/4 x 1-1/4	1-1/4 x 1-1/4	1-1/4 x 1-1/4
	(CM)		3.175 x 3.175	3.175 x 3.175	3.175 x 3.175	3.175 x 3.175
CAPACITY-TOTAL	MBH		1,200	1,200	1,200	1,200
	(KW)	351.6	351.6	351.6	351.6	
RELIEF VALVE TYPICAL - 150 PSIG (1034.0 KPA)						
QUANTITY		(1) 6021DC01	(1) 6021DC01	(1) 6021DC01	(1) 6021DC01	(1) 6021DC01
SIZE	INCHES	1/2 x 3/4	1/2 x 3/4	1/2 x 3/4	1/2 x 3/4	1/2 x 3/4
	(CM)	1.27x1.905	1.27x1.905	1.27x1.905	1.27x1.905	1.27x1.905
CAPACITY-TOTAL	MBH	925	925	925	925	925
	(KW)	271.0	271.0	271.0	271.0	271.0

* Output based on nominal 80% of input. Actual combustion efficiencies will be higher and fuel dependent.