



# SERVICE AND PARTS MANUAL

## SIGNATURE SERIES

MODEL		MODEL		MODEL	
OVEN STD IGNIT	ML-044905	VSB36IR	ML-044936	VIR35M	ML-044961
STD OVEN	ML-044906		ML-044937	VIR36FM	ML-044962
CONVOVEN	ML-044907	VRBS48	ML-044938	VCB25M	ML-044963
VCB25S	ML-044908	VRBS60	ML-044939	VCB36M	ML-044964
VCB36S	ML-044909	VRBS72	ML-044940	VCB47M	ML-044965
VCB47S	ML-044910	VRBS96	ML-044941	VCB36	ML-044966
VGf18	ML-044911	VRBR36	ML-044942	VCB36C	ML-044967
VS12T	ML-044912	VRBR48	ML-044943		ML-044968
VS12F	ML-044913	VRBR60	ML-044944		ML-044969
VS18T	ML-044914	VRBR72	ML-044945	VO236	ML-044970
VS18F	ML-044915	VRBR96	ML-044946		ML-044971
VS24T	ML-044916	VIR36	ML-044947		ML-044972
VS24F	ML-044917	VIR36C	ML-044948		ML-044973
VS36T	ML-044918	VIR36S	ML-044949		ML-044974
VS36F	ML-044919	VIR36F	ML-044950		ML-044975
VS12S	ML-044920	VIR36FC	ML-044951		ML-044976
VS18S	ML-044921	VIR36FS	ML-044952		ML-044977
VS24S	ML-044922	VRB36	ML-044953		ML-044978
VS36S	ML-044923	VRB36C	ML-044954		ML-044979
VS12M	ML-044924	VRB36S	ML-044955	VCM24R	ML-135124
VS18M	ML-044925	VRB36F	ML-044956	VCM36R	ML-135126
VS24M	ML-044926	VRB36FC	ML-044957	VCM48R	ML-135127
VS36M	ML-044927	VRB36FS	ML-044958	VCM60R	ML-135128
VFM18	ML-044928	VRB36M	ML-044959	VCM72R	ML-135129
VSB36R	ML-044935	VRB36FM	ML-044960	VCM84R	ML-135130

### IMPORTANT FOR YOUR SAFETY

**THIS MANUAL IS PREPARED FOR THE USE OF TRAINED VULCAN SERVICE TECHNICIANS AND SHOULD NOT BE USED BY THOSE NOT PROPERLY QUALIFIED. IF YOU HAVE ATTENDED A VULCAN SERVICE SCHOOL FOR THIS PRODUCT, YOU MAY BE QUALIFIED TO PERFORM ALL PROCEDURES DESCRIBED IN THIS MANUAL.**

**THIS MANUAL IS NOT INTENDED TO BE ALL ENCOMPASSING. IF YOU HAVE NOT ATTENDED A VULCAN SERVICE SCHOOL FOR THIS PRODUCT, YOU SHOULD READ, IN ITS ENTIRETY, THE REPAIR PROCEDURE YOU WISH TO PERFORM TO DETERMINE IF YOU HAVE THE NECESSARY TOOLS, INSTRUMENTS AND SKILLS REQUIRED TO PERFORM THE PROCEDURE. PROCEDURES FOR WHICH YOU DO NOT HAVE THE NECESSARY TOOLS, INSTRUMENTS AND SKILLS SHOULD BE PERFORMED BY A TRAINED VULCAN SERVICE TECHNICIAN.**

**REPRODUCTION OR OTHER USE OF THIS MANUAL, WITHOUT THE EXPRESS WRITTEN CONSENT OF VULCAN-HART COMPANY IS PROHIBITED.**



# TABLE OF CONTENTS

INTRODUCTION .....	4
Service Notes .....	4
Product Features and Descriptions .....	4
UNCRATING/SETUP .....	6
INSTALLATION REQUIREMENTS .....	6
GAS CONNECTIONS .....	7
GAS PRESSURE REQUIREMENTS .....	7
GAS PRESSURE CHECK PROCEDURES .....	8
Steps .....	8
VENTILATION REQUIREMENTS .....	9
PILOT ADJUSTMENTS .....	10
BURNER ADJUSTMENTS .....	10
BATTERY INSTALLATION .....	12
THERMOSTATS .....	15
CALIBRATION OF THERMOSTATS .....	16
Standard Oven with FDTO Thermostat .....	16
Snorkel Oven and/or Electric Ignition Oven with KX Thermostat .....	17
Griddles with BJWA Thermostat .....	18
OVEN ELECTRIC IGNITION SYSTEMS .....	20
Spark System .....	20
BRASS VALVES .....	24
DOORS, DOOR SEAL, HINGES AND COUNTERWEIGHTS .....	25
Door Removal/Counterweight Replacement .....	25
CLEANING PROCEDURES .....	27
Cleaning Tips .....	28
SCHEDULED MAINTENANCE .....	29
Recommended Service Frequency .....	29
Inspection Items .....	29
TROUBLESHOOTING .....	30
PARTS .....	35

## INTRODUCTION

### Service Notes

The information in this manual is not intended to be all inclusive, rather it is a guide to the applications, specifications and requirements of the Vulcan-Hart appliance.

Vulcan-Hart appliances are not any different in concept, components or application than many other appliances.

Vulcan-Hart appliances are designed to provide years of high performance. It is imperative that the installation requirements, operating guidelines and maintenance procedures be followed to ensure long life and maximum performance.

If the installation and/or appliance has not met the requirements outlined in this manual, please notify the Vulcan-Hart Company, the end user and all other parties involved.

### Product Features and Descriptions

The Signature Series Range line is an extra heavy-duty product, commonly referred to as hotel and/or institutional cooking equipment.

The gas line is a 1 1/4" front manifold, battery-type appliance. Chassis come in a variety of widths: 12", 18", 24" and 36".

Top configurations available:

- Open burners in 12" and 18" sections
- Cast-iron hot tops in 12" and 18" sections
- Manual and thermostat griddles in 12" increments
- Graduated hot top (French top)

Standard and convection ovens are available on 36" chassis only.

On the 12", 18" and 24" chassis, the base of the oven is called a skeleton which is an open storage compartment.

The third configuration is a modular unit. It has a top section without a base and is mounted to an angle iron base with 1 1/4" pipe legs.

**OPEN BURNERS** - The standard burner comes rated at 30,000 BTU/hr with a four slot, lift-off burner cap. There are four other types of burner caps available. The no-slot types are used for large diameter cookware. There are 8-, 12- and 16-slot caps for direct centered heat used in sauté applications.

**HOT TOPS** - Full hot tops are rated at 35,000 BTU/hr and are available in 12" and 18" widths. Half hot tops (rear only) are rated at 17,500 BTU/hr and are also available in 12" and 18" widths.

**GRADUATED HOT TOPS** - (French Top) This configuration is rated at a total of 50,000 BTU/hr. The large burner is rated at 25,000 BTU/hr. The medium burner is rated at 14,000 BTU/hr and the small burner is rated at 11,000 BTU/hr.

**GRIDDLES** - Rated at 30,000 BTU/hr per burner. Manual control is standard. BJWA modulating thermostats are available. Griddles are in 12" increments with one manual valve or thermostat per 12" section.

**STANDARD OVEN** - Rated at 40,000 BTU/hr. The interior dimension is 27" wide x 28 1/2" deep x 14 1/2" high and is supplied with one oven rack. The rack guides have four positions. The door is counterbalanced. The thermostat is a modulating FDTO type with a temperature range of 250°F to 500°F degrees.

## Product Features and Descriptions (Cont.)

**SNORKEL CONVECTION OVEN** - Rated at 30,000 BTU/hr. The interior dimension is 26 1/4" wide x 23" deep and 14" high. The oven cavity is fully porcelainized. The door is also counterbalanced. Three oven racks are supplied and the rack guides have four positions. The thermostat is a "snap action" KX type with a temperature range of 200°F to 500°F degrees. There is a 1/4 HP fan motor that requires 115 Volt minimum 15 amp service.

**LEGS/CASTERS** - Standard units are supplied with four 6" legs. For curb installation, leveling bolts are available. Casters are available with 3" or 5" diameter wheels. Legs, casters or curb bolts are all 5/8" x 11 stems.

**BACK RISERS** - The standard unit is equipped with a 6" stainless steel stub riser. Also available are single and double-deck risers with or without shelves and reenforced high shelves capable of mounting a Cheesemelter or Salamander broiler. Another option is 48", 60" and 72" back risers in the same configurations capable of spanning more than one unit. These wider back risers are special order only. All back risers are attached to the units via a 2" x 4" female receiver on the top rear of the chassis and all high shelves/stub risers are interchangeable.

**EXTERIOR FINISHES** - The standard finish is black powder coat paint. All chassis's are powder coated prior to assembly. The most common exterior finish is stainless steel on the front. Stainless steel sides are available as an option. Cast-iron open burners and grates are painted with a light coat of water based enamel. The water-based enamel is intended to protect the raw cast iron during transit and storage only. Cast iron hot tops and steel griddle plates are coated with a USDA-approved oil that must be removed prior to operation.

**SPREADERS** - These are non-functional items that are designed to offer a work surface between appliances and/or a place to locate a pressure regulator in a battery line up. The standard spreader comes with the continuous gas manifold, back riser and a top surface only. A front apron is available.

**GAS CONNECTIONS** - The standard unit is supplied with a 1 1/4" front manifold with a male union fitting on the left side of the appliance, and the female union fitting is on the right side of the appliance. As an option, a rear gas tailpipe connection is available in either 1 1/4" or 3/4". Also this rear gas connection can be used to interconnect a cheese melter or salamander broiler that is mounted to the re-enforced high shelf. Manifold caps and cover plates are available for stand-alone units or battery end units.

**MISCELLANEOUS and SPECIALS** - There are many other configurations available in the Signature line including models for back-to-back island installations. Special wide and/or long bull noses to span up to 108" in length and 8 3/4" in width. Additionally, back risers can be special ordered to span up to 72" in width.

Whenever dealing with any unit or configuration that seems unfamiliar, always secure the serial numbers and relay that information to the factory for the specifics of the appliance.

Also available in the Signature line are double-stacked standard ovens, fryers, pasta cookers, single and double-deck top-fired broilers and refrigerated bases. Only Vulcan-Hart Cheesemelters and Salamander broilers can be mounted to the Signature line.

## UNCRATING/SETUP

All Vulcan-Hart appliances are inspected and tested for function before leaving the factory. The transportation company assumes responsibility for safe delivery of the shipment. Should an appliance arrive with apparent and/or hidden damage, see the freight damage section of this manual.

- Uncrate the appliance; carefully remove all tie-down straps and packing material.
- Locate and identify any and all loose pieces such as oven racks, rack guides, casters, legs, pressure regulator, back shelves and owner's manual.
- Locate the rating plate and check the specifications (gas type/electrical). If they do not match the utility connections, do not proceed with the installation. Contact the dealer and/or Vulcan-Hart Customer Service.
- Note the model and serial number of the appliances and retain for future reference.
- Place the appliance in the proximity of its final location, install legs/casters and then inspect gas connection points for obstructions and/or debris.
- Place the unit in its final location. Using a carpenter's level, on the oven bottom or a solid portion of the chassis, check the appliance to ensure it is level from side to side and front to back. Using the bullet foot, level as necessary.
- For multiple unit installations (battery installations) see the battery installation section of this manual.
- Casters are non-leveling. If the floor is more than  $\frac{1}{8}$ " out of level, it is recommended that casters not be used.

## INSTALLATION REQUIREMENTS

The installation must allow for adequate clearances for service and operation with a minimum of 36" in front of the appliance.

Models with 30,000 BTU burners must maintain 20" on the left and right sides as well as 2" in the rear to combustible materials. The older models with 20,000 BTU burners require 6" on the left and right sides as well as 2" in the rear to combustible materials. For non-combustible locations the clearances, are 0" left, right and rear.

Snorkel convection oven models require additional clearances in the rear for the fan motor to be able to cool itself, with a minimum of 2". When snorkel ovens are mounted on curbs and/or without legs, there must be at least 6" of airspace behind the appliance.

There must be an adequate supply of fresh air, based on BTU consumption and exhaust volume to ensure proper combustion as well as maximum performance.

The appliance or line up must be installed so the flow of combusted air/flue gasses are not obstructed or disturbed in any way. Make up air, fans or drafts directed at the rear of the appliance will obstruct, inhibit or disturb the flow of flue gasses. This will affect the oven and/or griddle performance, cause poor combustion and can damage the operating components, which will void the appliance warranty. Do not place wall mounted objects over the appliance.

Wall-mounted objects, appliances or shelves above the appliance will block the natural path of the flue gasses, which can slow or stop the appliance from fluing. This will cause problems and damage to operating components, which will void the appliance warranty.

Make up air, fans or drafts directed at the top or front of the appliance will cause problems with open burners, such as delayed ignition and poor performance.

## Installation Requirements (Cont.)

All appliances must be vented to the outside. Depending on local codes, the specifics may vary. Check with local authorities. Fluing occurs because heat rises vertically, which has no force behind it. Any obstruction or disturbance will negatively affect the appliances ability to flue itself. Make up or fresh air should be present low and in the front of the appliance.

Gas connector hoses shall be commercial grade and have the capability of supplying at least 10% more fuel than the maximum BTU consumption of the appliance or line up. Furthermore, gas connector hoses shall be no smaller than  $\frac{3}{4}$ " inside diameter.

When units are mounted on casters, the gas connector hose must comply with the current standard for movable gas appliances. Furthermore, the installation must provide for a restraining cable/chain device to limit the movement of the appliance or line up.

## GAS CONNECTIONS

**CAUTION:** ON ALL GAS SUPPLY CONNECTIONS ANY PIPE JOINT COMPOUND USED MUST BE RESISTANT TO THE PROPERTIES OF PROPANE (LP) GAS.

Before making any gas connections, be sure to check for obstructions or debris in the manifold pipe and union fitting. Once the appliance has been connected and the air has been purged from the system all the fittings and connections must be tested for leaks using a soap solution, or an appropriate gas leak-sensing instrument.

**WARNING:** DO NOT USE AN OPEN FLAME TO CHECK FOR GAS LEAKS.

If a gas leak is detected and cannot be stopped, shut off gas supply to the appliance or line up and contact your local gas provider or an Authorized Servicer.

## GAS PRESSURE REQUIREMENTS

Natural gas pressure should be 5" Water Column (W.C.) plus or minus  $\frac{1}{2}$ " W.C.

Propane (LP) gas pressure should be 10" W.C. plus or minus  $\frac{1}{2}$ " W.C.

On units that have infra-red burners such as Salamanders and Cheesemelters, the gas pressure variables are slightly different, plus  $\frac{1}{2}$ " W.C. minus .2" W.C. Example: on natural gas, 4.8" to 5.5" W.C., on propane (LP) 9.8" to 10.5" W.C.

All gas appliances must have a gas pressure regulator installed. In order for the pressure regulator to perform properly, the supply pressure must be greater than the operating pressure. For example, most cities supply 7" to 9" W.C. of natural gas pressure to a building.

Propane (LP) systems should supply 11" to 12" W.C. The appropriate pressure regulator will provide the correct pressure to the unit or line up.

Sometimes even though the gas pressure is correct, the appliance may not be able to function properly because the gas supply piping may be too small and is not able to supply the volume of gas required. It is recommended that the piping be able to supply a minimum of 10% more fuel than the maximum BTU consumption of the appliance or line up.

Because of the size of the Signature manifold ( $1\frac{1}{4}$ ") when a  $1\frac{1}{4}$ " pressure regulator is used, up to three appliances may be connected to one pressure regulator. For example, a battery line up of six units must be connected to two gas pressure regulators. A single appliance can be connected to a  $\frac{3}{4}$ " gas pressure regulator.

## GAS PRESSURE CHECK PROCEDURES

### Steps

1. Connect the manometer to the main gas manifold pipe of the appliance, or in a battery the center unit of the line up. If the pressure reading is taken at the oven burner or anywhere other than the main gas manifold pipe, the pressure drop can be 1" W.C. or greater and the test is invalid.
2. Fire up one burner and take a reading.
3. Fire up all the burners on the appliance and take a reading.
4. Fire up all the gas appliances on that supply line and take a reading.
5. At no time should the pressure drop more than  $\frac{1}{2}$ " W.C.

If the pressure is set at the recommended setting and the pressure drop is slightly under, or  $\frac{1}{2}$ " W.C., the regulator can be adjusted up to the maximum, for example, a 5.5" W.C. for natural and 10.5" W.C. for propane (LP). However, if the pressure drop is greater than  $\frac{1}{2}$ " W.C., it is likely a lack of volume due to too small of a supply line. Check with the gas provider for the proper size gas line.



## VENTILATION REQUIREMENTS

Depending on local codes, ventilation requirements may vary. A basic formula is as follows: 100 to 150 CFM (cubic feet per minute) per square foot of floor space that the appliance or line up occupies. For example, one standard six burner unit, which measures 36" wide by 38" deep, equals approximately 9 square feet of floor space, therefore 900 to 1,350 CFM of exhaust is required.

Units with charbroilers may require more CFM exhaust; check with local authorities.

The hood should extend a minimum of 6" over all exposed sides of an appliance or line up. Seldom can the units be without rear clearance, so figure 4" in the rear.

For every cubic foot of gas that is burned, 11 cubic feet of by-products are produced. These by-products must be vented to the outside.

Ventilation systems need to be properly balanced to ensure that all the by-products are exhausted. There must be an adequate supply of fresh air for proper combustion and still a very slight negative pressure in the kitchen.

Sometimes a hood system will be operating perfectly as per its manufacturer's specifications, however there is still a problem with the gas-cooking appliance. The hood system may not be compatible with the gas appliance under it. In these instances, the service contractor for the hood system and the appliance Servicer will have to work together to attempt to correct the problem. If it is determined that the hood system is not compatible with the appliances under it, it is imperative that this information be communicated to the end user, the dealer and all parties involved, especially the Vulcan-Hart Company.

If the fresh air system (make up air) is such that ovens and griddles are experiencing fluing problems, there will be component failures due to excessive heat. If the open burners are fluttering or blowing around due to make up air being directed at the top or front of the unit delayed, no ignition will occur, and the appliance's performance will be severely affected. If it is determined that any of these conditions exist, the appliance warranty will be voided.

Some cities allow the use of a direct vent system in lieu of a motor-driven exhaust system to vent a bake oven. Check with local authorities.

To increase appliance performance and minimize energy consumption of the ventilation system:

- Add side panels on canopy hoods.
- Avoid make up air diffusers close to hood or re direct air away from top and/or rear of appliance.
- Add multi-or variable-speed exhaust and make up air fan controls.

## PILOT ADJUSTMENTS

After all connections/fittings have been checked for gas leaks and no leaks are found, the pilots can be lit. Locate each pilot and the corresponding pilot adjustment valve. Light the pilots and adjust them up or down as necessary. The flame should be only high enough to ignite the corresponding burner within 3 or 4 seconds maximum.

Mushroom head-type pilots are used on open burners, griddles and hot tops. The flame should be only about the size of a dime. This type of pilot will burn yellow; that is the reason they should be as small as possible and still be able to ignite the burner, within 3 or 4 seconds, maximum (Diagram #2).

Orifice pilots with thermocouples or flame switches are used on ovens. The flame should be large enough to completely engulf the tip of the thermocouple/sensor and make the tip of the thermocouple/sensor glow red-hot. Orifice pilot flames should be sharp, well-defined, two-tone blue when burning natural gas. However, when burning propane (LP) there may be a tiny yellow tip to the flame. This yellow tip should be no more than 10% of the total flame size (Diagram #1).

All gas burners should ignite within 3 to 4 seconds, maximum. All burners are tested at the factory prior to shipment. However, fine tuning adjustments may be necessary to accomplish 3 to 4-second ignition at the installation site.

Most gas burners have an air shutter. There are two types of air shutters, the cap or disk type (Diagram #3) and the sleeve type (Diagram #4). The cap or disk type is used on burners with cast iron venturis. The sleeve type is used on tubular steel burners and/or burners with tubular steel venturis. All burners are tested and the air shutters are set at the factory prior to shipment. However the factory cannot make the fine tuning adjustments that may be necessary at the actual installation.

**DIAGRAM #1**

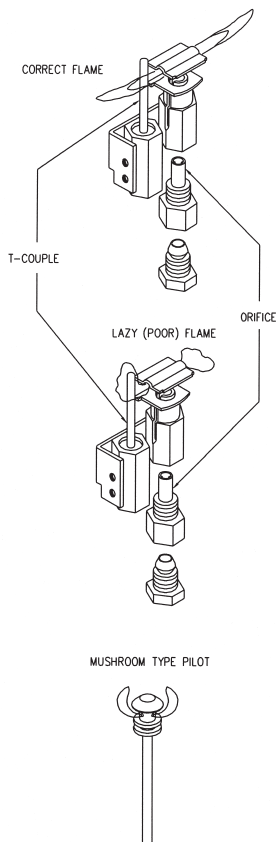

**DIAGRAM #2**



**DIAGRAM #3**



**DIAGRAM #4**

## BURNER ADJUSTMENTS

When using natural gas, the air shutter will be approximately 50% open. On propane (LP) the air shutter will be approximately 90% open.

If the flame is soft, lazy or yellow, there is not enough primary air and the air shutter needs to be opened up. In the event this does not solve the situation, check the burner for obstructions and clear as necessary. If the flame is lifting off the burner, there is too much primary air and the air shutter needs to be closed down (Diagram #5).

If grates, hot tops or oven bottoms have been removed, be sure to recheck flame adjustments with these items in place as the flame characteristics may change and additional adjustments may be necessary. Always recheck burner flames after the grates, hot tops and oven bottoms are in their proper place.

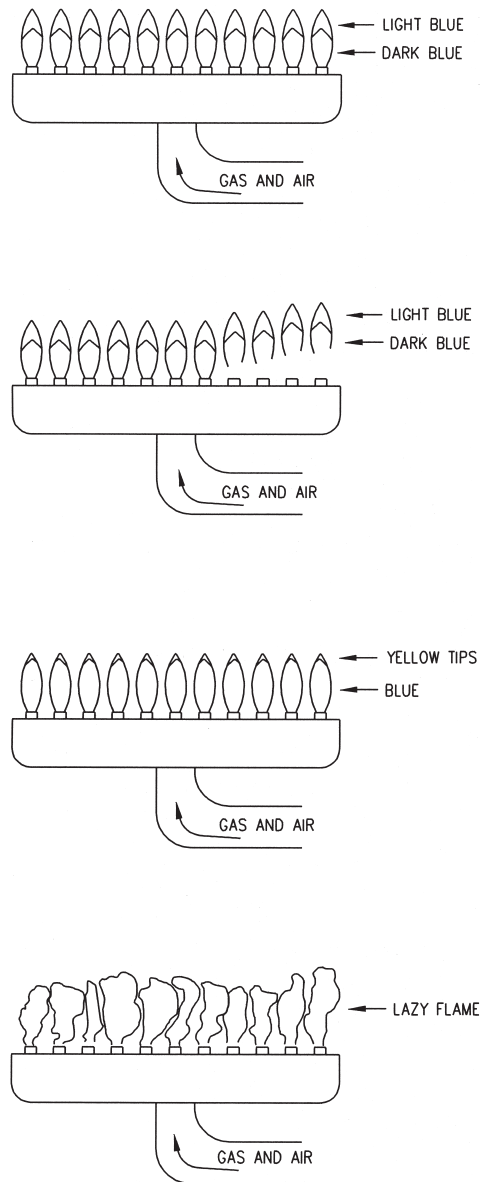

**DIAGRAM #5**

## BATTERY INSTALLATION

1. Remove grates, hot tops, knobs, front manifold cover and bull nose (Diagram #6).
2. Slide open burners and/or hot tops off the orifice/valve, but do not remove them from burner box. It is not necessary to remove griddle burners unless the griddle plate is already off the unit. Be careful that the weight of the griddle burner or burners does not cause the manifold pipe to rotate when the manifold mounting clamps are loosened.
3. Loosen manifold mounting clamps enough that the manifold pipe is free to move (Diagram #7).
4. Slide units together and level with bullet feet, as necessary, so that the manifold pipes mate up. If the pipes do not mate up, the units are not level. Do not use the manifold mounting clamps to compensate for anything other than very minor adjustments ( $\frac{1}{8}$ " or less). Units on casters will not level up if floor is not level. Casters must be installed wrench tight.
3. Engage the union nut with the opposing male union fitting and hand-tighten as much as possible until units are mated up (Diagram #7).
4. Locate mounting holes in the riser and top frame, then bolt the units together using the appropriate length  $\frac{1}{4}$ " bolts (Diagram #8 on page 14).
5. When all the units in the battery are connected, use a backup wrench on the manifold pipe to begin tightening the unions.

**CAUTION:** DO NOT ALLOW THE MAIN MANIFOLD PIPE TO ROTATE, AS THIS WILL DAMAGE THE PILOT LINES AND/OR VALVES AND MAY CAUSE GAS LEAKS.

6. Once all the units are bolted together and the unions are tight make sure all the valves are in the original level position. Retighten the manifold pipe mounting clamps.
7. Reinstall and bolt bull noses together (Diagram #6).
8. Reinstall any burners that were removed. Reattach the pilots that were removed. Check that burners and/or pilot lines and fittings are in their original position and have not been damaged.
9. Install pressure regulators as needed. No more than three units are to be connected to any one,  $1\frac{1}{4}$ " gas pressure regulator.
10. Connect battery to gas supply. Purge the air from the system. Check for leaks using a soap solution.

**WARNING:** DO NOT USE AN OPEN FLAME TO CHECK FOR GAS LEAKS.

11. Check and adjust gas pressure if necessary (see gas pressure adjustment and gas pressure check sections of this manual).
12. Thoroughly check all units for packing material, protective coatings and manuals before lighting any pilots.
13. Begin lighting and adjusting pilot flames (see pilot adjustment section of this manual).
14. Check and adjust all burners as necessary (see burner adjustment section of this manual). All burners should light within 3 or 4 seconds, maximum. It may be necessary to remove grates, hot tops, oven bottoms and possibly the griddle plate to make the necessary adjustments.
15. At this point if no problems are noted the battery is ready to be started up. If any problems are noted they must be corrected before the battery can be put into operation. AN AUTHORIZED SERVICER MUST MAKE ALL REPAIRS to ensure the factory warranty is not compromised.

# DIAGRAM #6

## STEP A

REMOVE ROLL FRONT AND MANIFOLD COVER

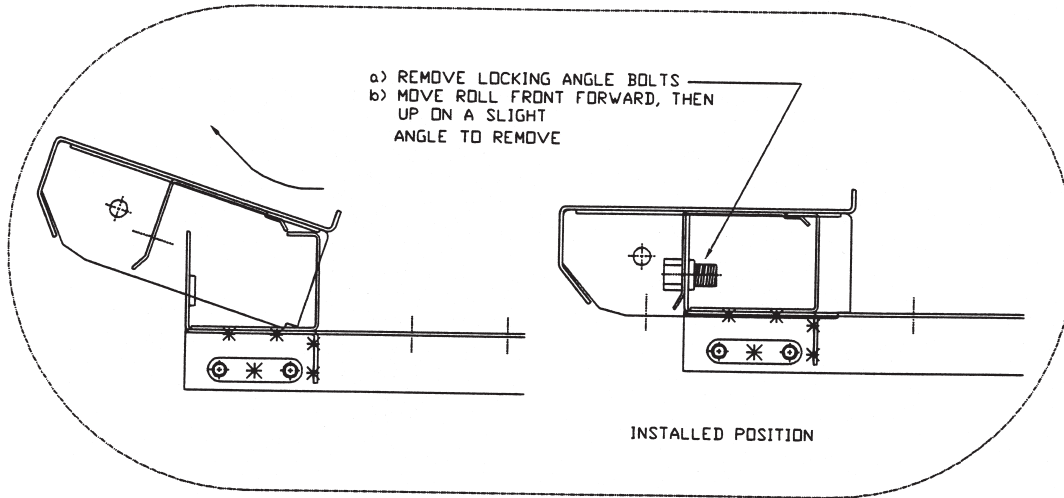

## STEP B

LOOSEN MANIFOLD MOUNTING BRKTS  
START UNION AND TIGHTEN  
(DO NOT ALLOW MANIFOLD PIPE TO TURN)  
SECURE MOUNTING BRKTS.  
TEST FOR GAS LEAKS  
(SEE OPERATING INSTRUCTIONS)  
REINSTALL MANIFOLD COVERS

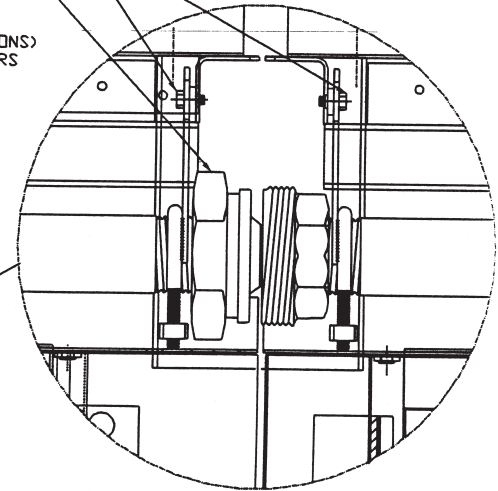

## STEP C

PLACE ROLL FRONT IN ITS INSTALLED POSITION  
BOLT ROLL FRONTS TOGETHER USING THE FOLLOWING:

- ONE 1/4-20 X 3/4" BOLT #30101
- ONE 1/4-20 NUT #30505
- TWO FLAT WASHERS #30307
- ONE SPLIT WASHER #30311

IN THE FOLLOWING SEQUENCE:

- BOLT
- FLAT WASHER
- CHASSIS
- FLAT WASHER
- SPLIT WASHER
- NUT
- REINSTALL LOCKING ANGLE BOLTS  
(SEE STEP A)

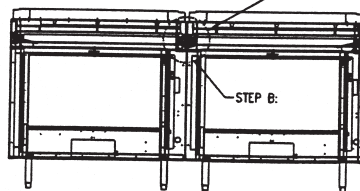

FRONT VIEW

# DIAGRAM #7

STEP D

CLAMP CHASSIS TOGETHER AT THE REAR

INSTALL (AS SHOWN):

ONE 1/4-20 x 3" BOLT,

PART #30120

ONE 1/4-20 NUT,

PART #30505

TWO WASHERS,

PART #30307

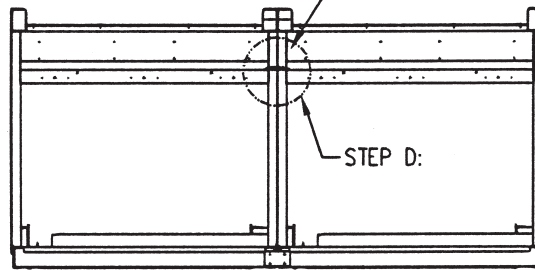
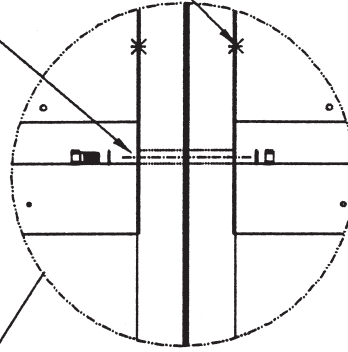

TOP VIEW

STEP E

BOLT RISERS TOGETHER

USING THE FOLLOWING:

ONE 1/4-20 x 3/4" BOLT #30101

ONE 1/4-20 NUT #30505

TWO FLAT WASHERS #30307

ONE SPLIT WASHER #30311

IN THE SAME SEQUENCE AS STEP C:

STEP F

IF SHELF IS PROVIDED,  
FOLLOW STEP E TO BOLT  
THE SHELVES TOGETHER  
THEN REMOVE THE CLAMP  
AT THE REAR OF THE UNIT

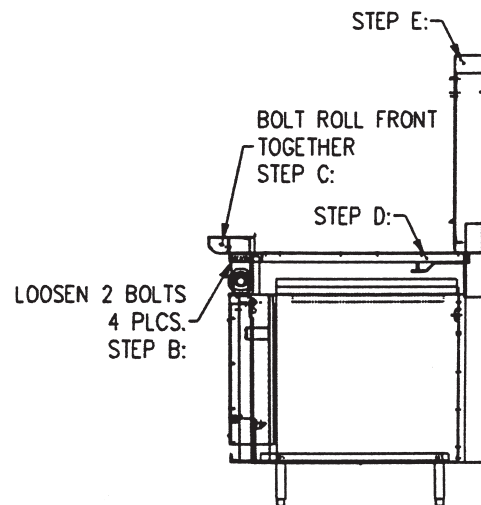

SIDE VIEW

**DIAGRAM #8**

## THERMOSTATS

The standard oven uses an FDTO-type, modulating thermostat. When first turned on, the flame comes on full speed, approximately 1 1/4" to 1 1/2" tall. As the temperature approaches the set point, the flame slowly reduces in size. When the temperature is achieved, the flame should be in bypass, approximately 1/8" tall. The bypass flame will keep the oven temperature constant unless the door is opened and heat is lost.

When the oven needs to recover heat loss, the thermostat will allow the flame to slowly increase in size until the temperature is again at the set point. Usually the thermostat does not require calibration, however it may need to have the bypass flame set at the time of installation. The temperature accuracy of this thermostat is 25°F. For calibration and/or bypass adjustment, see thermostat calibration section of this manual.

Snorkel and electric ignition ovens use a KX-type snap action thermostat. When first turned on, the flame comes on full speed. When it achieves the set temperature, it shuts off. When 10°F to 15°F is lost, the thermostat will come on full speed to recover the heat loss. Due to the fact the thermostat shuts completely off and the oven is constantly venting heat off through the flue, the thermostat will cycle on and off throughout the cooking process. The temperature accuracy of the KX thermostat is 15°F to 20°F. If calibration is required, see the calibration section of this manual.

The thermostat used on griddles is a BJWA modulation type. When first turned on the flame comes on full speed, approximately 3/4" to 1" tall. As the temperature approaches the set point, the flame is slowly reducing in size. When the temperature is achieved, the flame should be in bypass. Bypass flame for griddles should only be big enough to keep the burner lit all the way around, with little blue dots of flame.

This type of thermostat by design will allow the temperature to creep if the griddle is left idling, with no product on the griddle, for a minimum of 50°F an hour. Therefore it is imperative that the bypass flame be correct. If the bypass flame is not correct, the temperature will creep to 100°F to 200°F an hour. Temperature accuracy of the BJWA thermostat is 25°F. For calibration/bypass adjustments see the calibration section of this manual.

**NOTE:** Calibrations and/or bypass adjustments require a good working knowledge of the components and system as well as specific test instruments and should only be performed by authorized service personnel. When checking calibrations on the BJWA griddle thermostat, it is necessary to begin the procedure when the griddle is cold. Attempting to calibrate the BJWA griddle thermostat from other than a cold start is extremely difficult, as well as time consuming, and can cause the temperature to be incorrect at a later time.

## CALIBRATION OF THERMOSTATS

Field recalibration is very seldom necessary on new appliances, however older thermostats may require calibration. Recalibration should only be considered when cooking results definitely indicate the thermostat is not maintaining the set temperature. Before attempting recalibration, the temperature should be checked with a temperature test instrument or a reliable thermometer.

### Standard Oven with FDTO Thermostat

1. Place the test instrument sensor or thermometer in the center of the oven cavity and close the door.
2. Turn oven on, set the thermostat dial to 300 degrees and allow the oven to cycle several times (at least 20 minutes).
3. Turn the thermostat dial back to the lowest temperature setting. Check the bypass flame; it should be  $\frac{1}{8}$ " tall. Adjust bypass as necessary (Diagram #9).
4. Turn thermostat dial back to 325°F and allow 5 minutes for temperature to stabilize. If temperature is more than 20°F different from the dial setting, calibrate as follows.
  - A. Remove dial and loosen the calibration plate screws until the calibration plate moves freely. Gently attach dial and turn until the dial setting matches the actual oven temperature (Diagram #9).
  - B. Hold calibration plate. Gently remove dial and tighten calibration plate mounting screws. Apply adhesive material to calibration screws
  - C. Replace dial and increase temperature 50°F. Allow 10 minutes and recheck the temperature.
  - D. If temperature is still more than 20°F different from the dial setting, the thermostat may need to be replaced.

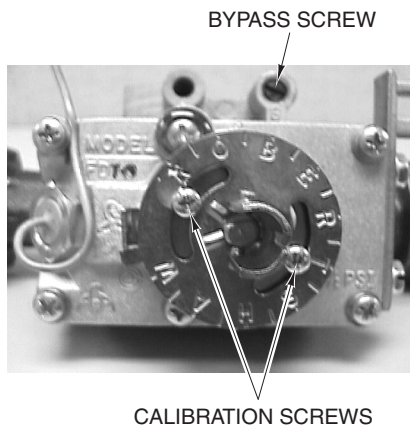

**DIAGRAM #9**

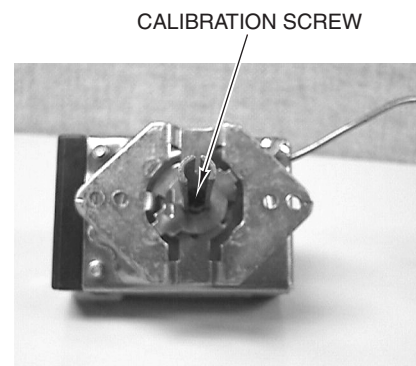

**DIAGRAM #10**



## Snorkel Oven and/or Electric Ignition Oven with KX Thermostat

1. Place the instrument sensor or thermometer in the center of the oven cavity and close the door.
2. Turn fan switch on. Set temperature dial to 300°F. Allow oven to cycle at least five times (approximately 15 minutes). If the temperature is more than 15°F different from the dial setting, calibrate as follows.
  - A. Pull the dial straight off. Turn the calibration screw (Diagram #10) clockwise to decrease temperature or counterclockwise to increase temperature ( $\frac{1}{4}$  turn equals approximately 35°F).
  - B. Replace dial and increase temperature 50°F. Allow oven to cycle at least three times and recheck the temperature.
  - C. If the temperature is more than 15°F different from the dial setting, the thermostat may need to be replaced.

## Griddles with BJWA Thermostat

Before attempting recalibration on the BJWA thermostat, a temperatures check must be done from a cold start, before the griddle has been idling and the temperature has had a chance to creep up. All temperature readings and/or calibrations must be performed from a cold start. Thermostats can be rendered inoperative by improper calibration and/or adjustments.

- Clean the griddle plate and make sure there is no carbon buildup on the cooking surface. Carbon buildup will cause a false temperature reading.
- Remove the temperature dials and manifold cover. Locate sensor probes. Temperature readings can only be taken directly over the sensor probes. The sensor probes will be located as follows. Approximately 6" from the left side splash, then 12" spacing and the last sensor probe will be approximately 6" from the right side splash (Diagram #11).
- Once the left to-right locations is identified, measure 12" from the front of the cooking surface. That is where the temperature readings will be taken.
- Pull off all the thermostat dials. Using a screwdriver from the back of the dial, push out the center chrome cap of the dial. Replace dial on the thermostat.
- Turn the dial to 300°F. The flame should be approximately  $\frac{3}{4}$ " to 1" tall. Allow about 15 minutes for plate to heat up.
- Turn the dial to the lowest temperature setting (150°F). Check the bypass flame; it should be only big enough to keep the burner lit all the way around (little blue dots of flame). Adjust as necessary (Diagram # 12).
- Take note of the size of the bypass flame, as it will be necessary to recognize when the thermostat is in bypass throughout the calibration process.
- Turn the dial up enough for the flame to come on at least  $\frac{1}{4}$ " tall. When the flame is in bypass, again take a temperature reading in the area previously identified as the probe location. If the temperature is more than 25°F different from the dial setting, calibrate as follows.
- With the dial in place, use a small screwdriver through the opening in the front of the dial locate and depress calibration screw, Do not turn the calibration screw. Rotate the dial to match the actual temperature on the griddle plate. Release the calibration screw.
- Turn the dial to increase the temperature 50°F. Watch flame and as soon as the flame is again in full bypass, take a temperature reading. If the temperature is more than 25°F different than the dial setting, the thermostat may need to be replaced.
- Once the thermostat is determined in calibration, that thermostat should be turned off so as not to cause false readings on the other zones.
- Repeat the process for each thermostat zone.
- Once all the thermostats are calibrated, reassemble the dials and reinstall the manifold cover and the thermostat dials.

**NOTE:** Although the BJWA thermostat is a very simple and basic thermostat, it is somewhat difficult to calibrate due to the fact that once the bypass is set, it must be recognized as in full bypass at the time the temperature reading is taken. Additionally, if the temperature reading is not taken as soon as the thermostat is in full bypass, the temperature will begin creeping up and a true temperature reading will not be possible.

In the event a thermostat has to be replaced, use extreme care when handling and installing the sensor probe. Do not kink or severely bend the probe. Do not allow direct flame to come in contact with the probe or the capillary line. Any excess capillary line should be gently coiled up in an area that is away from direct flame and/or working or cleaning areas. Warranty does not cover thermostats that have been rendered inoperative by improper adjustments and/or calibrations or by work being performed by unqualified personnel.

# DIAGRAM #11

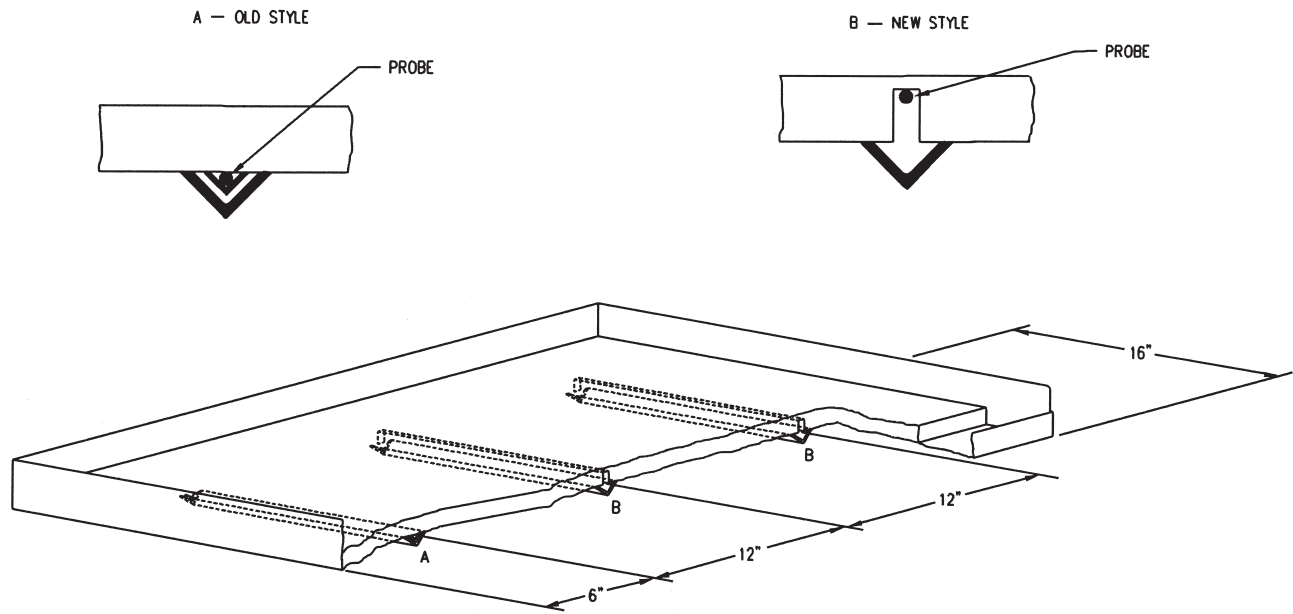

# DIAGRAM #12

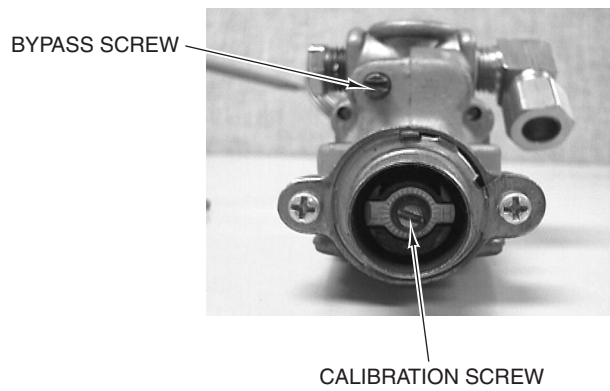

## OVEN ELECTRIC IGNITION SYSTEMS

### Spark System

The spark system has had two different spark modules used. Until late 1993 a white Robert shaw SM2 module was used. This spark module was not polarity sensitive. Early 1994 the units have a blue technical components 0+1 spark module. The technical components spark module is polarity sensitive. When changing from Robert shaw to technical components, the polarity must be checked with a meter prior to connecting the module.

**NOTE:** Do not rely on the original wire hookups as the polarity may not be correct and the technical components module will not stop sparking (See wiring diagram #13).

Both of these spark modules sense the presence of pilot flame and stop sparking automatically by sensing the change in resistance when the spark has to travel through the pilot flame. Therefore it is imperative that the high voltage lead wire not have any nicks, cuts or splices. Also, where the high voltage lead wire connects to the spark module, the connector must be clean and tight. A poor ground will cause either module to not stop sparking.

# DIAGRAM #13

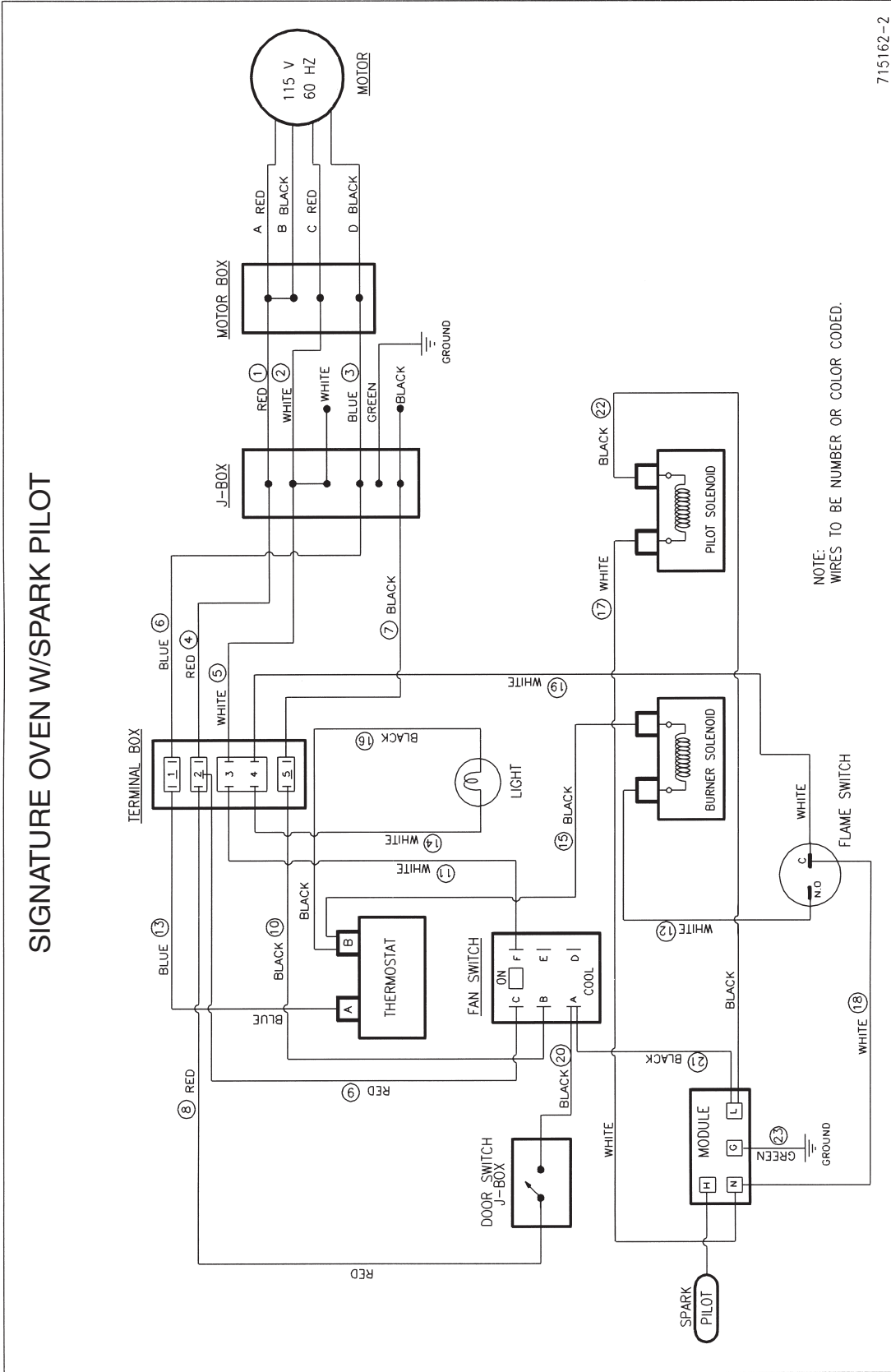

# DIAGRAM #14

## SIGNATURE CONVECTION OVEN W/ELECTRIC IGNITION

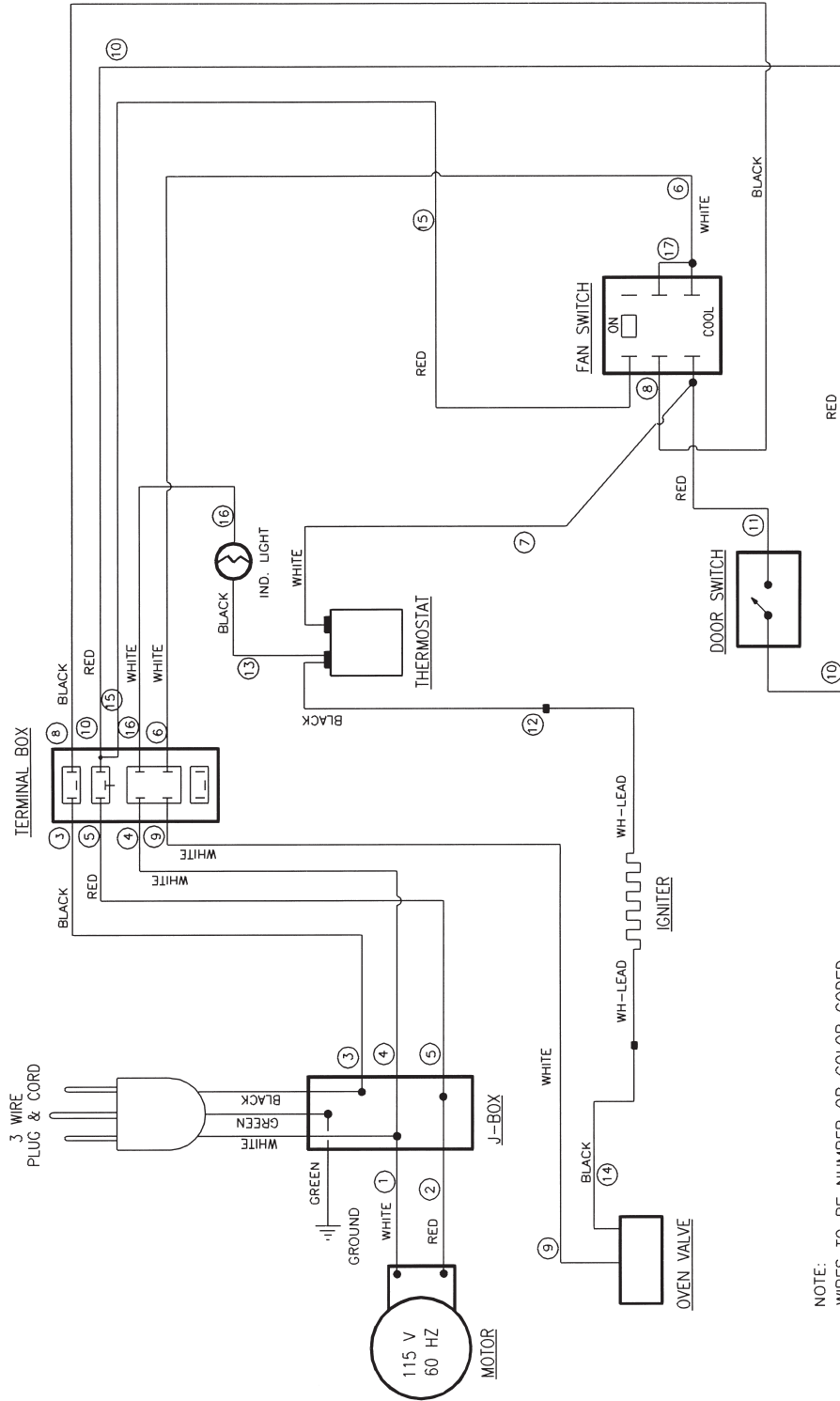

NOTE:  
WIRES TO BE NUMBER OR COLOR CODED.

715157

**DIAGRAM #15**

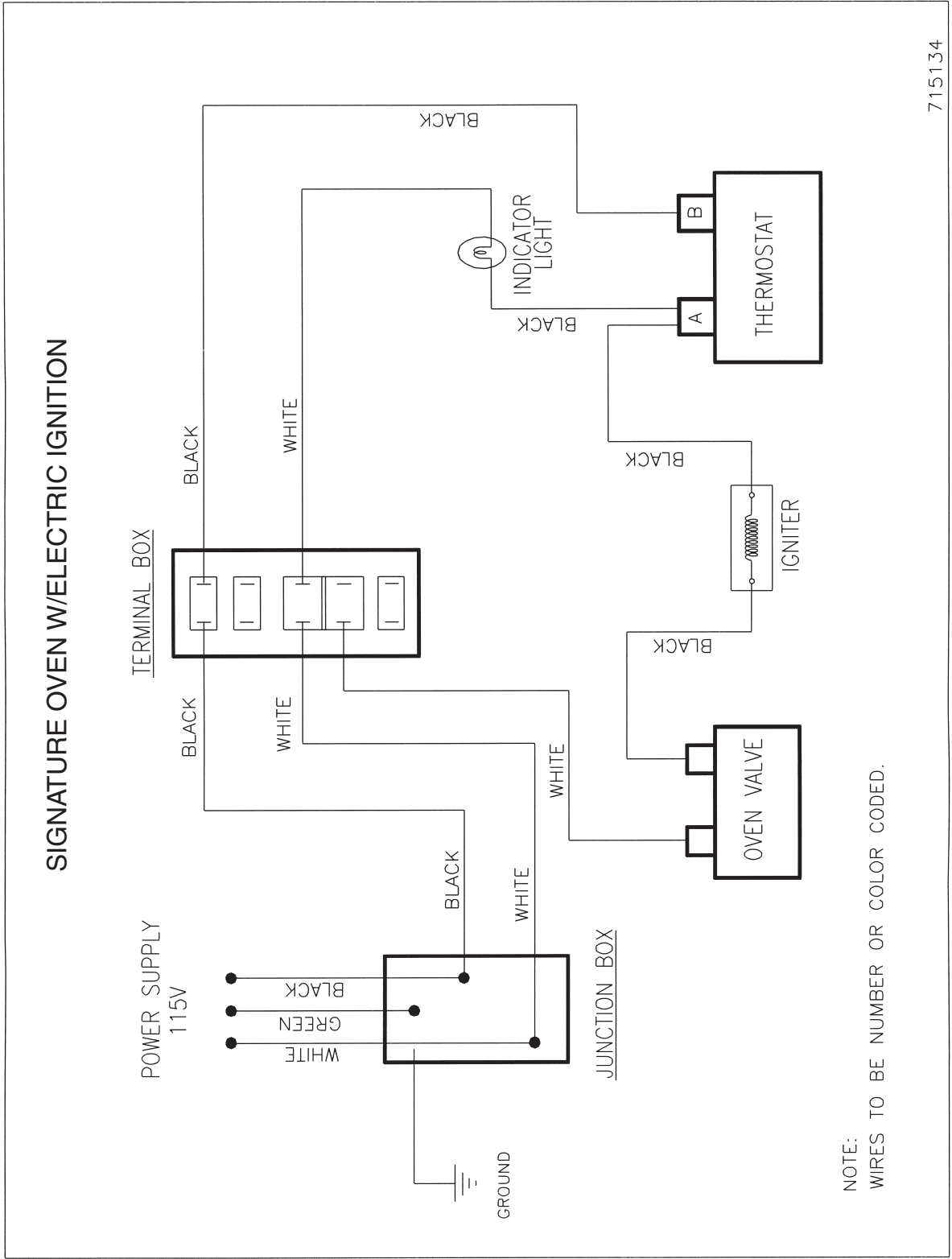

## BRASS VALVES

To service the new style valve, the two screws must be removed. Carefully remove the stem and spring. Using long nose pliers, pull the plug out. Clean the plug and core with a soft cloth. Inspect the plug and core. Look for scoring. If either piece is scored, the valve must be replaced. If there is no scoring, apply a thin coat of graphite-based gas valve grease to the plug.

Reinstall the plug into the core and rotate the plug in the core to distribute grease in the core. Remove plug; reapply another thin coat of grease to the plug. Reinstall plug into core (be sure that plug is in the off position when the stem is installed, with the flat side on the bottom). Reinstall the spring, washer and stem. Reinstall the collar with the screws (Diagram #16).

**NOTE:** The new-style valve has a spring that can be easily lost. It is a spring that is approximately half the size of a ballpoint pen spring. In addition to the spring there is a washer, a metal collar and two small screws. All pieces must be reassembled onto the valve.

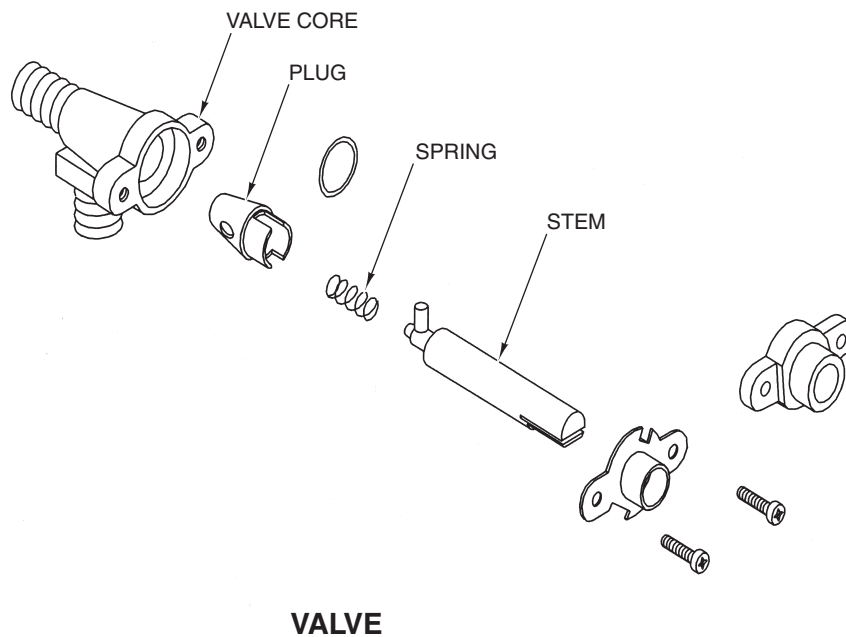

**DIAGRAM #16**



## DOORS, DOOR SEALS, HINGES AND COUNTERWEIGHTS

### Door Removal/Counterweight Replacement

- Using a flat blade screwdriver, remove two screws on each side of the door (Diagram #17).
- With door part-way open, pull the door straight up.
- Remove E clip and pull out door hinge pin (Diagram #18).
- Counterweight is removed through the oven cavity (Diagram #19).

**DIAGRAM #17**

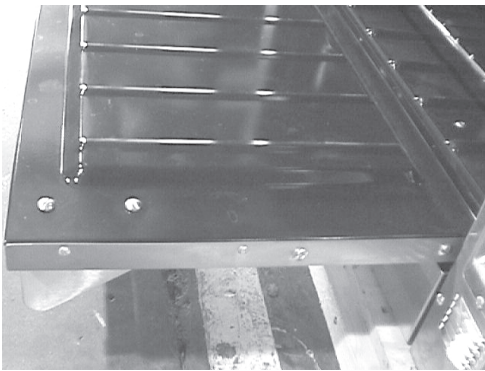

**DIAGRAM #18**

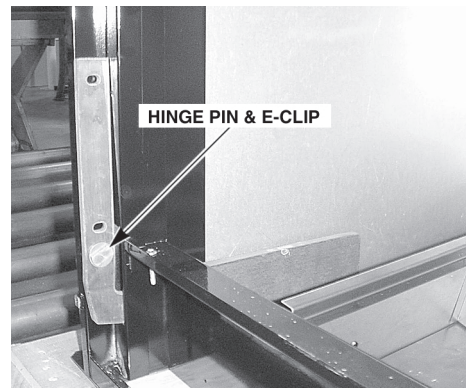

**DIAGRAM #19**



BURNER	BTU	ORIFICE, NAT	ORIFICE, LP
OPEN TOP MODEL	30,000	# 43	# 53
OPEN TOP (old style)	20,000	# 47	# 54
FRY TOP/GRIDDLE	30,000	# 41	# 52
FULL HOT TOP	35,000	# 37	# 50
HALF HOT TOP	17,500	# 49	# 55
STANDARD OVEN	40,000	# 35	# 48
OVEN PILOT (standard)		p/n 720426	p/n 715007
CONVECTION OVEN	30,000	# 41	# 52
OVEN PILOT (electric ignition)		p/n 720041	p/n 712363
FRENCH TOP OUTER (large)	25,000	# 43	# 53
FRENCH TOP CENTER (medium)	14,000	# 52	# 59
FRENCH TOP INNER (small)	11,000	# 53	# 62
SALAMANDER CI (each)	11,000	# 53	# 61
SALAMANDER IR	30,000	# 41	# 52
PILOT FOR IR BURNER		p/n 711339N	p/n 711339
CHARBROILER (each)	14,500	# 50	# 56
CHEESEMELTER 15" BURNER	18,000	# 55	# 48
CHEESEMELTER 26" BURNER	30,000	# 43	# 53
PILOT FOR MODEL		p/n 720426	p/n 715007
CHEESE MELTER OLD STYLE		# 57	# 70
PILOT	6,000	p/n 711376	p/n 712316

**\*All sizes are rated for sea level**

## CLEANING PROCEDURES

Housekeeping/cleaning is a vital part of appliance maintenance. Individual procedures will vary from operation to operation. When properly cleaned and well-maintained, Vulcan-Hart appliances will provide many years of reliable performance. The information provided is intended to provide general information about the materials which Vulcan-Hart uses in its equipment.

**PAINTED SURFACES** - Use a soft cloth with mild detergent and warm water. Wipe off spills as they may occur with a soft cloth and warm water. Do not use abrasives or harsh chemicals on painted surfaces.

**STAINLESS STEEL SURFACES** - Stainless steel is resistant to most cleaners, so detergent or degreasers can be used. Be sure to read the instructions on the product before using it on your appliance. A petroleum-based stainless cleaner/polish may be used on exterior areas that are not near a cooking surface. Abrasive cleansers and/or cleaning pads will scratch the surface..

**CAST IRON GRATES** - The grates can be cleaned by using a wire brush or a steel wool pad. Also, the grates can be cleaned in a dishwasher, however rust may occur. To help retard rust after water is used, a light coat of cooking oil can be applied to the grate. If oil is applied, the grates will smoke when the burners are used; therefore the oil must be "burned off" before using the burner to cook product.

**CAST IRON HOT TOPS** - The top surface of the cast iron hot top can be cleaned by using a steel wool pad or an abrasive scrubber. Occasionally the bottom side of the hot top should be inspected for carbon and/or soot and cleaned as necessary with a wire brush.

**STANDARD OVEN INTERIOR** - The standard oven has a porcelain coating on the bottom (floor) of the cavity as well as the inner liner of the door. These surfaces can be cleaned with a commercial degreaser or oven cleaner. The side walls, ceiling and back wall of the oven cavity is made of aluminized steel, which can be cleaned with a noncaustic cleaner. The use of caustic cleaner will damage the aluminized steel; a detergent-based cleaner is recommended.

**SNORKEL CONVECTION OVEN** - The entire oven cavity is coated with porcelain and can be cleaned with a commercial degreaser or oven cleaner. The fan cover and blower wheel is made of aluminized steel. Caustic cleaners will damage the aluminized material and should not be used on these parts. Use of water on or near the fan should be minimized.

**OVEN RACKS and GUIDES** - The racks are chrome plated and can be cleaned in a dishwasher. A steel wool soap pad can be used in conjunction with a commercial de-greaser or oven cleaner.

**GRIDDLE PLATES** - Allow the plate to cool to approximately 250°F. Apply a small amount of water on the griddle plate (amount that can be controlled with a spatula). At 250°F the water will boil and loosen the cooking debris, use the spatula to scrape off the stubborn debris. Use a clean towel to wipe up the debris. Use abrasive (griddle stone, griddle screen or a product called Scotch Brick) with oil or water. Use the abrasive to remove the carbon buildup. Wipe the plate with a cloth. Apply a small amount of cooking oil. Spread the oil evenly over the surface.

## Cleaning Tips

The main purpose in cleaning a griddle plate is to remove the cooking debris and prevent carbon buildup. Product will stick to a new griddle plate due to the fact that steel is porous. After a griddle has been used, the pores of the steel will fill with carbon and the plate will be almost nonstick due to the fact that carbon has filled the pores of the steel plate. However, excessive carbon buildup will decrease the performance of the griddle and there will be taste transfer to the food product. Occasionally (once or twice a year) it is recommended that a commercial grill cleaner be used.

Whenever a cleaning product is used, the product instructions must be read, understood and followed. Be extremely careful when using any and all caustic cleaners, as they do pose a safety hazard to the user as well as a potential hazard to any food product that may come in contact with the product itself or the residue. Make sure to thoroughly wash the unit with fresh, clean water before cooking again.

Be advised that after a cleaner is used on the plate, product will likely stick until the pours are again filled with carbon. After a grill cleaner has been used, product sticking can be reduced by heating the griddle plate to approximately 300°F, rubbing beef fat on the plate and allowing the grease from the fat to lightly burn into the plate.

Constant use of griddle cleaners will cause a grease-bubbling effect around the perimeter of the griddle plate. This occurs because the splashes are welded to the bottom surface of the griddle plate and there is a slight gap on the cooking surface in which grease will accumulate. Normally this grease will solidify and become carbon; and the carbon will fill the gap. The cleaner will break down the carbon barrier that has been formed, and new grease and/or water residue will bubble up. Therefore this situation can be avoided by allowing the grease to solidify and create a carbon barrier.

## SCHEDULED MAINTENANCE

In order to provide maximum performance and proper operation, and to ensure the safety of the operator, all equipment must be serviced at least once a year by an authorized servicer. If for any reason an appliance has not been in use or has been in storage for any time, it is imperative that the unit be inspected by an Authorized Servicer prior to reinstallation and/or operation.

### Recommended Service Frequency

- 10 to 12 hours of operation per day, 7 days a week, every 30 to 60 days.
- 8 to 12 hours of operation per day, 5 days a week, every 90 days.
- 4 to 6 hours of operation per day, 5 days a week, every 120 days.
- Limited daily usage, every 180 days.

### Inspection Items

- Check for the slightest odor of gas. If detected, locate and correct as necessary.
- Check for valves that are hard to turn or that are seized up.
- Verify that all burners light in 2 or 3 seconds.
- Check that all burner ports are clean.
- Check that burners burn sharp, clean and blue, not yellow. Propane (LP) may have a small yellow tip.
- All pilots are lit and set to the proper height (see pilot adjustment section).
- Look for grease, debris and/or carbon buildup.
- Check all moving parts for ease of movement and/or wear.
- Verify that thermostats are functioning and temperatures are correct.
- Inspect and verify that all panels, covers, racks and rack guides are intact and properly installed and are not binding or falling out.

If any of these items are found to be incorrect, malfunctioning or in need of attention, immediately contact an Authorized Servicer to repair or correct the problem.

## TROUBLESHOOTING

### Problem

### Probable Cause

Oven will not hold temperature.

- Thermostat out of calibration.
- Bypass flame too high or too low.
- Oven door not closing properly.

Oven slow to heat.

- Low gas pressure.
- Wrong orifice.
- Vent in pressure regulator blocked.
- Oven door not closing properly.

Oven will not recover.

- Bypass flame too low. Low gas pressure.
- Vent in pressure regulator blocked.
- Oven door not closing properly.

Product (in oven) not cooking evenly.

- Wrong orifice.
- Unit not level.
- Burner deflector or oven bottom warped.
- Door not closing properly.
- Product placement improper.
- Gas pressure fluctuating.

Product (in oven) dried out.

- Temperature too high or too low.
- Thermostat out of calibration.
- Too long of a baking time.

Griddle will not hold temperature.

- Thermostat out of calibration.
- Bypass flame too high.
- Vent in pressure regulator blocked.
- Gas pressure fluctuating.
- Wrong dial on thermostat.

## TROUBLESHOOTING

### Problem

Griddle will not heat evenly.

### Probable Cause

- Unit not level.
- Wrong orifice.
- Flue obstructed.
- Gas-to-air ratio incorrect.
- Burner ports obstructed.

Product sticking to griddle.

- Temperature too high.
- Griddle not reseasoned after cleaning.
- Excessive carbon buildup on griddle.

Burner valves hard to turn.

- Valve lubricant dissipated.
- Valve core/plug scored.
- Dirt/debris in valve.
- Valve stem or knob rubbing on front panel.

Top burner will not light.

- Wrong orifice.
- Gas-to-air ratio incorrect.
- Incorrect gas pressure.
- Vent in pressure regulator blocked.
- Pilot burner positioned incorrectly.
- Burner ports obstructed.
- Obstruction in venturi.
- Make-up air/drafts directed toward burner.
- Water or grease in burner.
- Pilot flame too big or too small.

## TROUBLESHOOTING

### Problem

Oven burner will not light.

### Probable Cause

- Pilot flame too low or not lit.
- Pilot burner not positioned properly.
- Wrong burner orifice.
- Gas pressure incorrect.
- Vent in pressure regulator blocked.
- Gas-to-air ratio incorrect.
- Draft or air movement around oven burner.
- Oven burner obstructed.
- Oven burner baffle out of position.
- Oven burner not on orifice correctly.

Oven pilot outage.

- Pilot orifice obstructed.
- Low gas pressure.
- Insufficient gas volume.
- Vent in pressure regulator blocked.
- Oven flue obstructed or disturbed by draft.
- Poor pilot flame. Pilot burner deteriorated.
- Draft or breeze near floor.
- Burner box cover missing.
- Excessive door slamming.
- Thermocouple MV output low.
- Failed safety valve.

Griddle will not recover.

- Thermostat swing beyond specification.
- Thermostat out of calibration.
- Wrong orifice. Low gas pressure.
- Thermostat sensor not in correct position.
- Gas-to-air ratio on burner incorrect.
- Bypass flame too low to keep burner lit.
- Product volume beyond griddle capacity.
- Product placement incorrect.



## TROUBLESHOOTING

### Problem

Gas odor.

### Probable Cause

- One or more pilots not lit.
- Quick disconnect fitting not properly engaged.
- A burner is not on the orifice fitting properly.
- Poor combustion on one or more burners.
- A burner is not completely lighting.
- Loose and/or broken gas line or fitting.
- Leak in gas connector hose.
- Pressure regulator ruptured.

Oven pilot will not light (standard oven).

- Air not purged from gas lines.
- Red button not depressed long enough.
- Pilot orifice clogged.
- Incorrect pilot orifice.
- Excessive air movement in pilot area.
- Failed safety valve.
- Failed thermocouple.

Oven pilot will not light (with spark ignition).

- Failed spark module.
- Broken or deteriorated spark wire.
- Door seal missing.
- Snorkel tube loose or missing.

## TROUBLESHOOTING

### Problem

Charbroiler will not heat evenly.

### Probable Cause

- Valves turned on too high.
- Incorrect orifice.
- Orifice obstructed.
- Gas pressure too high.
- Radiants warped.
- Burners deteriorated.
- Gas pressure fluctuating.
- Grates obstructed with cooking/product debris.

Repeated component failure.

- Improper use of appliance.
- Fluing problem.
- Poor housekeeping.
- Water damage.
- Not properly installed.
- Make-up air/draft problem.
- Insufficient exhaust.
- Repairs made using incorrect/non-OEM parts.
- Gas pressure too high.
- Power surge.
- Poor electrical ground.

## TROUBLESHOOTING

### Problem

Stainless steel turning blue.

### Probable Cause

- Direct flame hitting panel.
- Temperature hitting over 500°F.

Stainless steel turning brown.

- Product spill-over not removed and burning.
- Grease-laden air being cooked on surface.

Paint peeling or flaking.

- Surface being hit by direct flame.
- Exposed to harsh cleaner/chemical.
- Exposed to grease and/or acidic juices.

Griddle plate turning blue.

- Temperature hitting over 500°F.
- Thermostat out of calibration.
- Failed thermostat.

Griddle plate turning black.

- Too high of a cooking temperature.
- Product residue burning on plate.
- Temperature hitting over 500°F.
- Thermostat out of calibration.
- Failed thermostat.

# PARTS

## Standard Burners

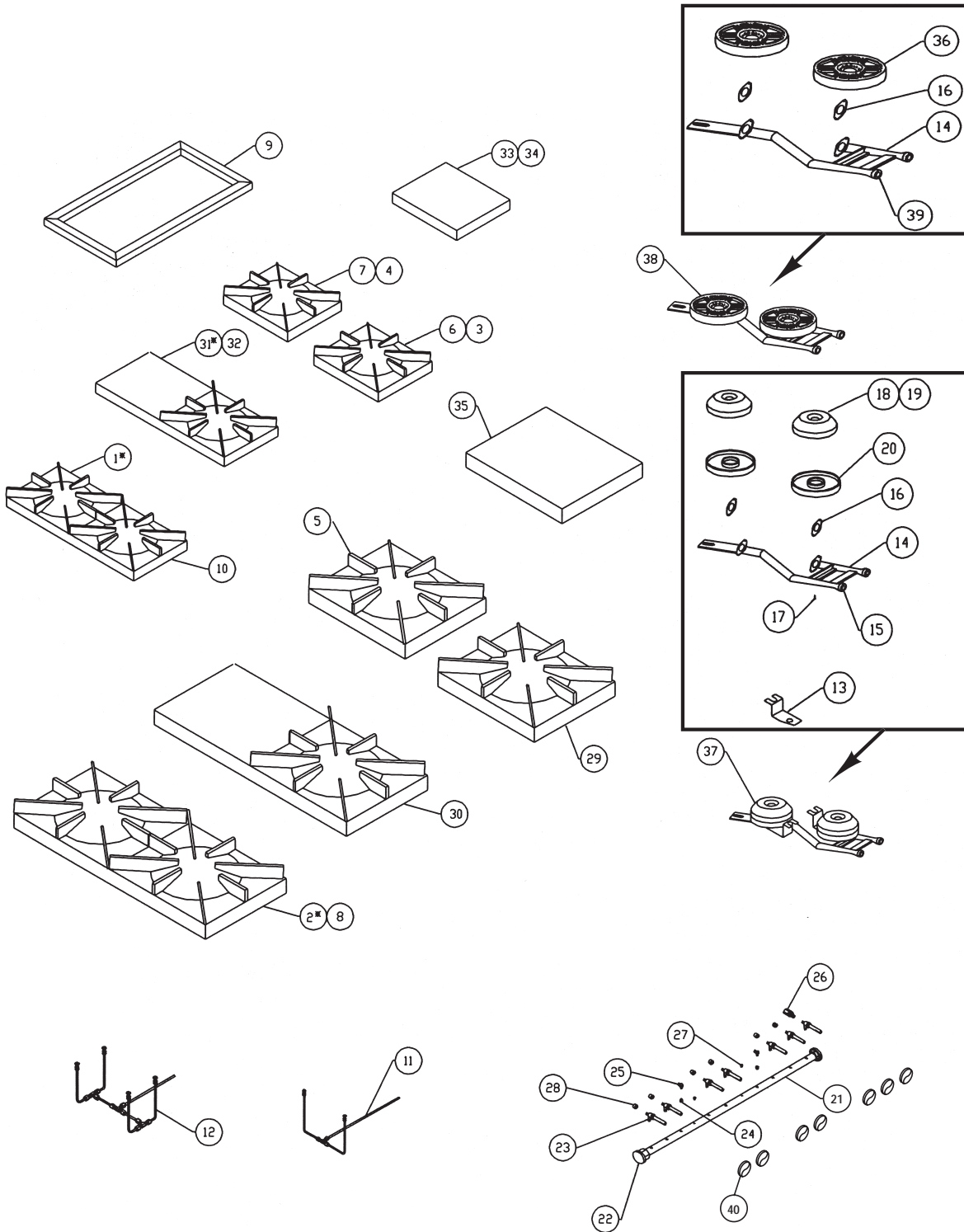

**NOTE:** For standard parts informatin on Signature Series, Cheesemelters, Charbroilers, Infrared Broilers and Fryers, reference supplement parts manual F-31210.

## Standard Burner Parts

ITEM	P/N	DESCRIPTION
* 1	715507	OPEN TOP GRATE (12" X 27")
* 2	715511	OPEN TOP GRATE (18" X 27")
3	720671	FRONT OPEN TOP 12"
4	720672	REAR OPEN TOP 12"
5	720675	REAR OPEN TOP 18"
6	715536	FRONT GRATE STEP UP UNIT (12 3/8" X 11 7/8")
7	715534	REAR GRATE STEP UP UNIT (14 3/8" X 11 7/8")
8	720566	18" OPEN TOP
9	762330A	STEP UP FRAME 36"
10	720567	12" OPEN TOP
11	762971A	PILOT TUBE ASSY (DOUBLE BURNER)
12	762972A	PILOT TUBE ASSY (4 BURNERS)
13	762346	PILOT TUBE BRACKET
14	719708	VENTURI (CAST IRON)
15	719241	AIR SHUTTER
16	714910	GASKET
17	730028	MOUNTING SCREW
18	715200-1	BURNER CAP
19	715200-2	BURNER CAP SLOTTED
20	715201-1	BURNER BASE PLATE
21	722326	MANIFOLD PIPE
22	715008	UNION 1 1/4"
23	715080	1/4 NPT TOP BURNER VALVE
24	719063	1/4" TO 1/8" REDUCING BUSHING
25	719187	1/8 NPT X 3/16CC PILOT VALVE
26	715121	STRAIGHT CONNECTOR
27	719200	1/8 NPT IRON PIPE PLUG
28	719951	ORIFICE
29	720674	FRONT OPEN TOP 18"
30	720568	18" HALF HOT TOP
* 31	715508	HALF HOT TOP/HALF OPEN TOP GRATE (12" X 27")
32	720565	12" HALF HOT TOP
33	762318	HALF HOT TOP STEP UP UNIT (USE ON REAR ONLY)
34	720673	REAR HALF HOT TOP 12"
35	720676	REAR HALF HOT TOP 18"
36	719706	OPEN TOP BURNER, HEAD ONLY
37	762970A	BURNER ASSY
38	706582A	OPEN TOP BURNER ASSY (FOR SERVICE ONLY)
39	719329	AIR SHUTTER
40	426745-1	KNOB CONTROL

# Hot Tops/Fry Tops

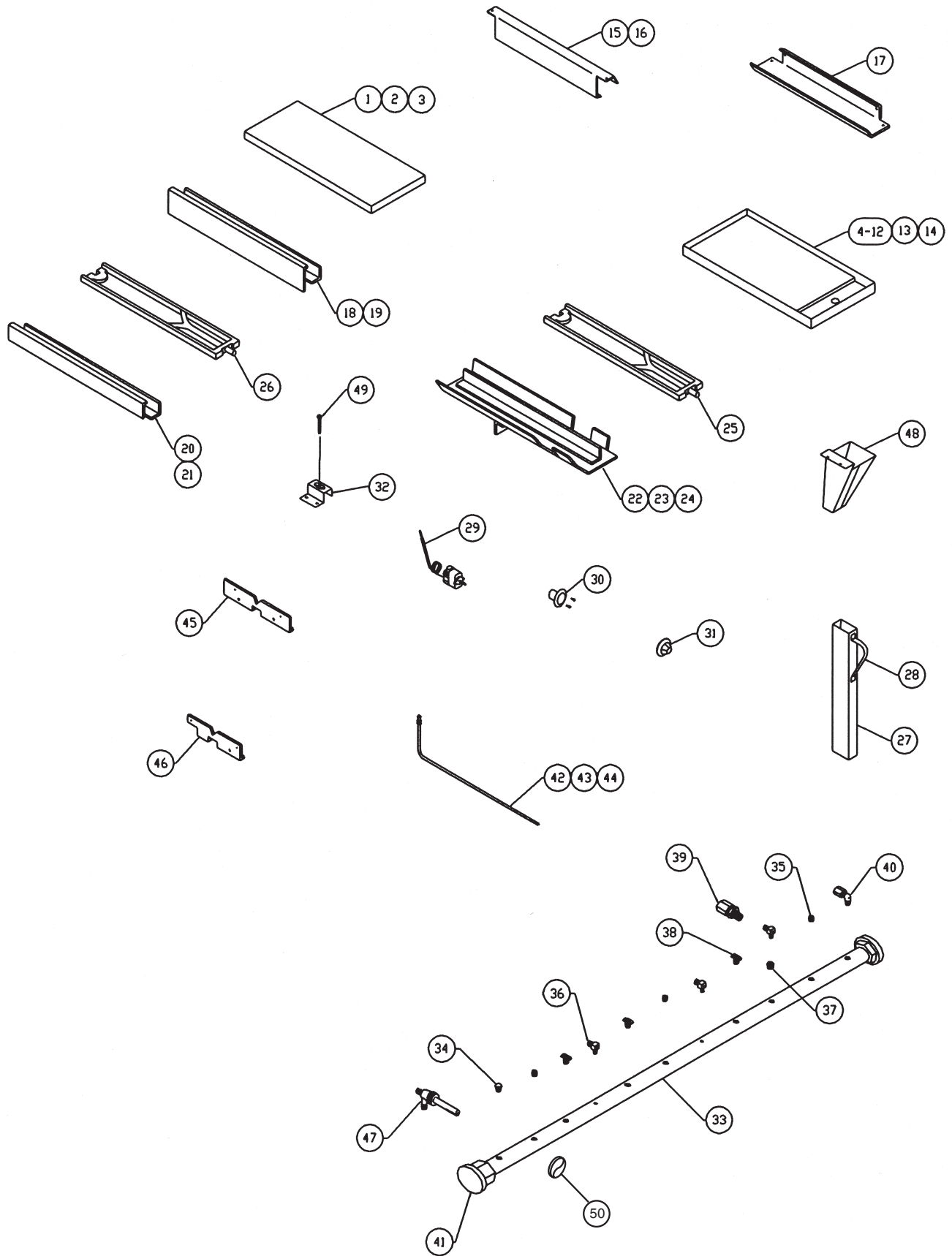

## Hot Tops/Fry Tops Parts

ITEM	P/N	DESCRIPTION
1	715038	HOT TOP PLATE (12" X 27")
2	720604	18" HALF HOT TOP
3	720605	12" FULL HOT TOP
4	707880A	12" FRY TOP 3/4" THK LH DRAIN
5	707881A	24" FRY TOP 3/4" THK LH DRAIN
6	707888A	24" FRY TOP 1" THK LH DRAIN
7	707882A	36" FRY TOP 3/4" THK LH DRAIN
8	707889A	36" FRY TOP 1" THK LH DRAIN
9	707883A	48" FRY TOP 3/4" THK (SPECIFY DRAIN LOC.)
10	707890A	48" FRY TOP 1" THK (SPECIFY DRAIN LOC.)
11	707891A	60" FRY TOP 1" THK (SPECIFY DRAIN LOC.)
12	707892A	72" FRY TOP 1" THK (SPECIFY DRAIN LOC.)
13	767164A	18" FRY TOP 1" THK LH DRAIN
14	767165A	18" FRY TOP T.G. 1" THK LH DRAIN
15	706081	RH END PLATE FT
16	706080	LH END PLATE FT
17	767169	RH & LH END PLATE 18" FT
18	706078	SEPARATION PLATE BETWEEN O.B. & FT OR HT (12" HP)
19	767180	SEPARATION PLATE BETWEEN O.B. & FT OR HT (18" HP)
20	706079	END PLATE HT
21	767179	END PLATE 18" HT
22	707870A	AERATION PLATE CTR HT-FT
23	707871A	AERATION PLATE CTR -TG GRILL
24	767170A	AERATION PLATE CTR 18" HT
25	707893A	FRY TOP BURNER ASSY, CAST IRON
26	707894A	HOT TOP BURNER ASSY, CAST IRON
27	707877A	GREASE CAN, RANGE UNIT
28	706084	HANDLE FOR GREASE CAN
29	719362	GRIDDLE THERMOSTAT
30	715075	GRIDDLE THERMOSTAT BEZEL
31	715074	GRIDDLE THERMOSTAT DIAL
32	705032A	GRIDDLE ADJ. BRACKET
33	715001	MANIFOLD PIPE
34	719371	1/4 NPT STEEL PIPE HEX PLUG
35	719364	1/4 STEEL PLUG (COUNTERSINK)
36	719193	1/8 NPT X 3/16 ADJ. PILOT VALVE
37	719063	1/4" X 1/8" REDUCING BUSHING
38	715084	1/4 NPT FLANGE NIPPLE
39	719141	1/8 NPT X 3/16cc STRAIGHT CONNECTOR
40	719158	1/4 NPT X 7/16cc 90° ELBOW
41	715008	UNION 1 1/4"
42	706771B	FRY TOP BURNER PILOT ASSY W/VALVE
43	706771A	PILOT STEM & TIP ONLY 8"
44	706770A	PILOT STEM & TIP ONLY 7"
45	706065	BAFFLE, FRONT - CENTER
46	706066	BAFFLE, FRONT - LEFT OR RIGHT
47	715080	1/4 NPT TOP BURNER VALVE
48	763011A	GREASE CHUTE
49	730117	LEVELING BOLT
50	426745-1	KNOB CONTROL

# French Top

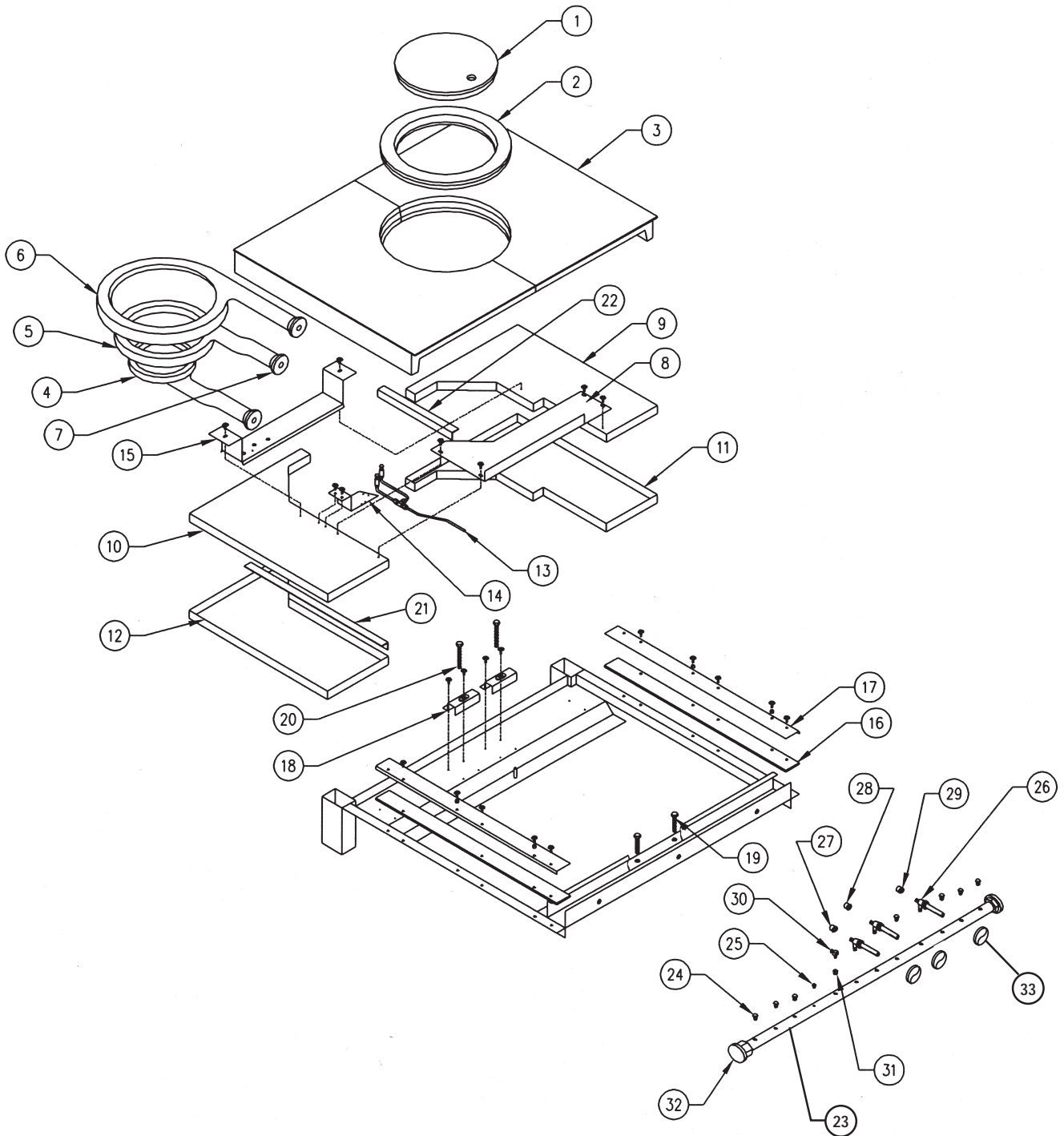



French Top Parts

ITEM	P/N	DESCRIPTION
1	715210	TOP CENTER CASTING
2	715211	TOP RING CASTING
3	715212	TOP RADIAL FINNED CASTING
4	715213	CENTER FRENCHTOP BURNER
5	715214	MIDDLE FRENCHTOP BURNER
6	715215	OUTER FRENCHTOP BURNER
7	719329	AIR SHUTTER
8	764907	CENTER HEAT PANEL
9	764908	TOP INSULATION PANEL - R/H
10	764909	TOP INSULATION PANEL - L/H
11	764910	BOTTOM INSULATION PANEL - R/H
12	764911	BOTTOM INSULATION PANEL - L/H
13	764923A	PILOT TUBE ASSEMBLY
14	787223	DUAL PILOT BRACKET
15	764916	BURNER SUPPORT BRACKET
16	764919	GRATE SUPPORT
17	764920	GRATE SUPPORT COVER
18	705032A	LEVELING BRACKET W/A
19		FRONT LEVELING BOLTS
20	730117	REAR LEVELING BOLTS
21		L/H BURNER SUPPORT REINFORCEMENT
22		R/H BURNER SUPPORT REINFORCEMENT
23	715216	MANIFOLD PIPE
24	719371	1/4" PLUG
25	719370	1/8" PLUG
26	715080	1/4 NPT VALVE
27	719951-53	ORIFICE
28	719951-52	ORIFICE
29	719951-43	ORIFICE
30	719193	SINGLE PILOT VALVE
31	719063	1/4 TO 1/8 REDUCING BUSHING
32	715008	1 1/4" UNION
33	426745-1	KNOB CONTROL

# Standard Oven

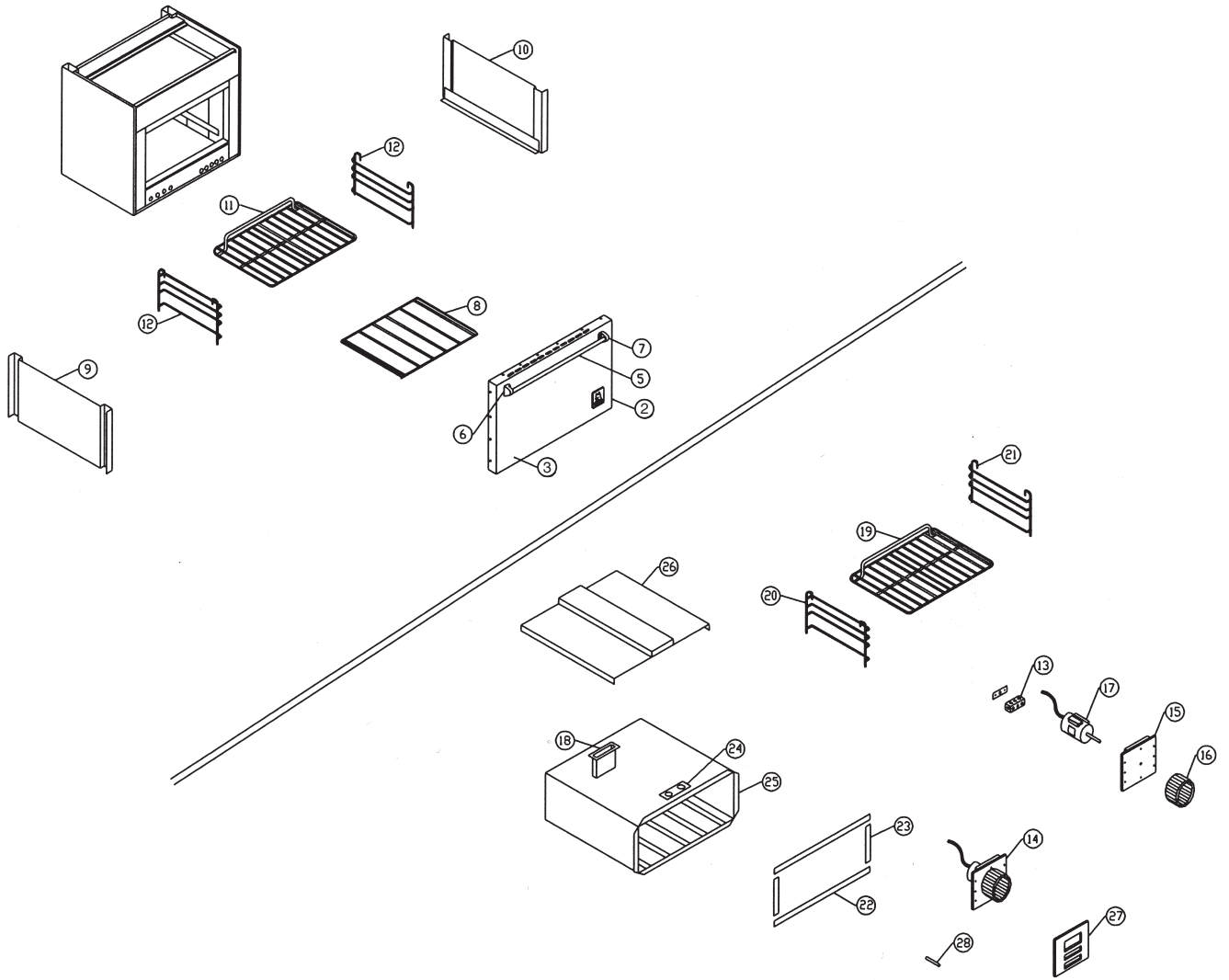

# Convection Oven

Oven Parts

ITEM	P/N	DESCRIPTION
2	788278A	OVEN DOOR COMPLETE, STAINLESS
3	788276	DOOR PANEL
5	715504	DOOR HANDLE
6	719621	DOOR HANDLE BRACKET, LEFT
7	719622	DOOR HANDLE BRACKET, RIGHT
8	707859	OVEN BOTTOM, PORCELAIN
9	707854A	OVEN SIDE LINER L
10	707855A	OVEN SIDE LINER R
11	715060	OVEN RACK
12	715026	OVEN RACK GUIDE ASSY, FITS L OR R
13	715123	TERMINAL BLOCK
14	751316A	MOTOR & FAN ASSY (115V)
15	751655A	MOTOR MOUNTING PLATE ASSY
16	715106	FAN BLOWER WHEEL ONLY (8" X 2-1/2")
17	715107	MOTOR ONLY (115V)
18	751341A	SNORKLER TUBE
19	718341	OVEN RACK (26-1/8" X 21")
20	715119-03	OVEN RACK GUIDE, LEFT
21	715118-03	OVEN RACK GUIDE, RIGHT
22	751442	HORIZONTAL DOOR SEAL
23	751443	VERTICAL DOOR SEAL
24	751355-A2	VENT TUBE ASSY
25	751641A	TANK ASSY
26	751369A	FLUE DUCT ASSY
27	751351A	FAN COVER FRONT SHIELD
28	715138	SLEEVE/SPACER

**Control System • Convection Oven**

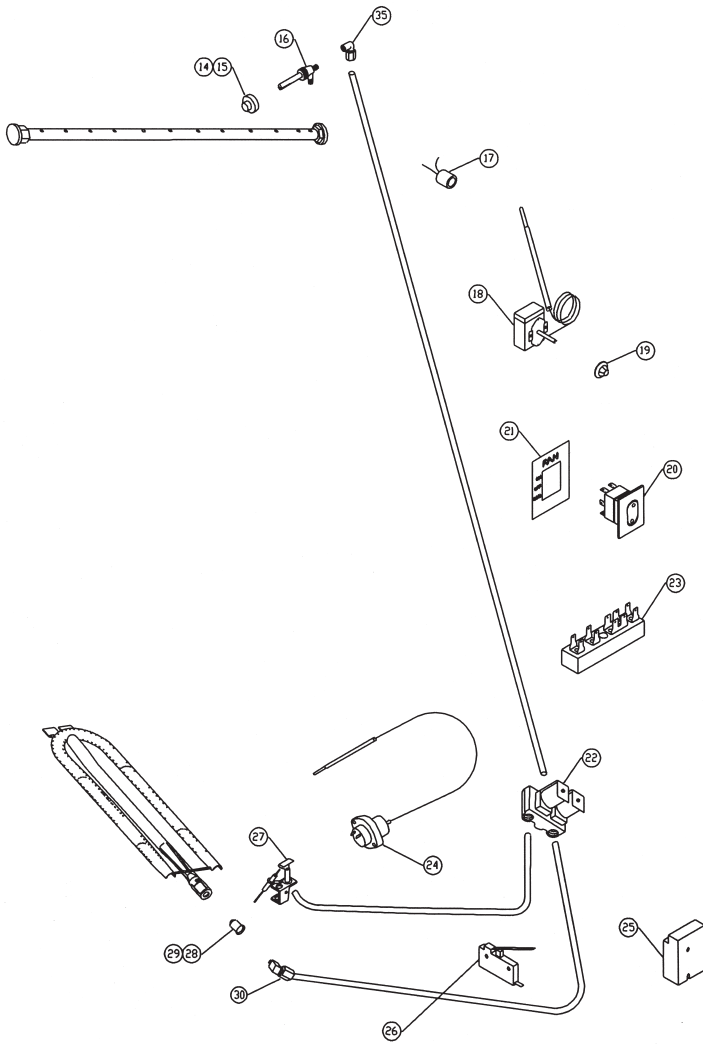

**Control System • Standard Oven**

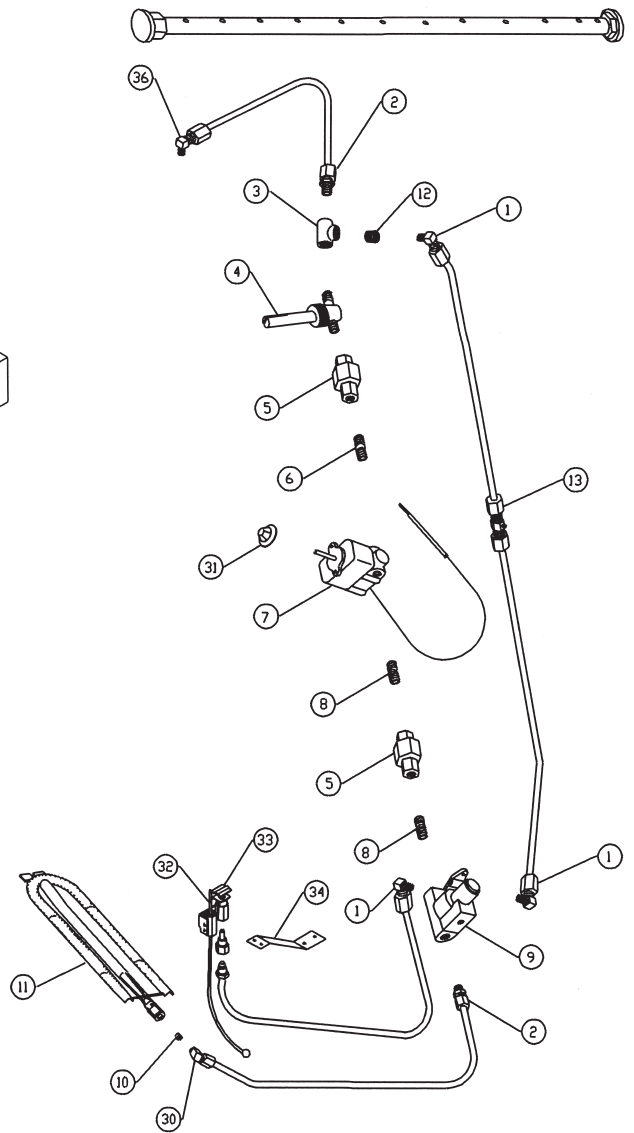

## Control System Parts List

ITEM	P/N	DESCRIPTION
1	719156	1/8 X 1/4cc BRASS ELBOW
2	719377	3/8 NPT X 3/8 STR BRASS CONNECTOR
3	719037	3/8 X 3/8 X 3/8 TEE
4	719971	SHUT OFF VALVE
5	719032	3/8 UNION
6	719055	3/8 X 1-1/4 NIPPLE
7	715048	FDT0 OVEN THERMOSTAT
8	719074	3/8 CLOSE NIPPLE
9	720719	BASO SAFETY VALVE
10	719951-35	ORIFICE
11	719737	OVEN BURNER
12	719066	3/8 X 1/8 REDUCING COUPLING
13	707648A	PILOT VALVE ASSY
14	719251	KNOB FOR OVEN VALVE, BLACK "S" TYPE
15	719258	KNOB FOR OVEN VALVE, RED
16	715080	ON-OFF VALVE FOR OVEN
17	720017	TEMPERATURE INDICATOR LIGHT, RED
18	719202	OVEN THERMOSTAT
19	719361	DIAL FOR OVEN THERMOSTAT
20	715112	FAN SWITCH, 3 POSITION ROCKER
21	715127	LABEL FOR FAN SWITCH
22	713656	DUAL SOLENOID
23	715123	TERMINAL BLOCK
24	714321	FLAME SWITCH
25	720385	SPARK MODULE, SINGLE (BLUE)
26	715122	DOOR SWITCH
27	714392	SPARK PILOT
28	720041	PILOT ORIFICE, NATURAL
29	712363	PILOT ORIFICE, LP
30	719385	ORIFICE ELBOW FOR OVEN BURNER
31	715059	OVEN THERMOSTAT DIAL (KNOB)
32	715005	OVEN SAFETY THERMOCOUPLE
33	715004	OVEN PILOT (NATURAL GAS)
34	706088	MOUNTING BRACKET FOR PILOT
35	719393	ELBOW 3/8 X 3/8cc
36	719376	BRASS ELBOW

# Body Parts/Shelves Risers

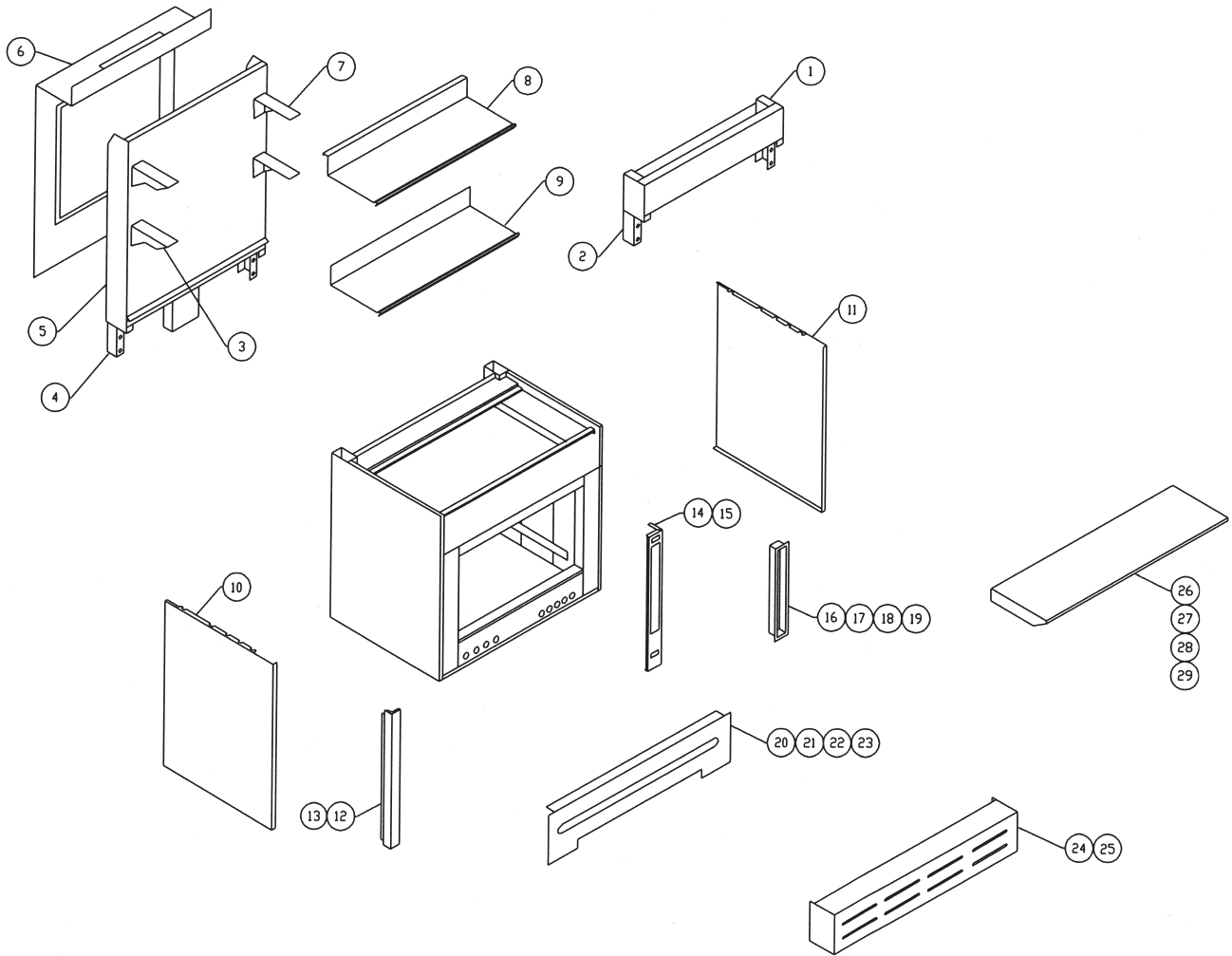

**Body Parts/Shelves Risers Parts List**

ITEM	P/N	DESCRIPTION
1	707969A	36" STUBBY - CR
	707974A	36" STUBBY - S/S
2	700385A	SUPER STRUCTURE STUB
3	715089	SHELF BRACKET L-PLATED
4	707964A	SUPER STRUCTURE
5	706237SST	DOUBLE DECK HI-SHELF FRONT
	706237CRS	DOUBLE DECK HI-SHELF FRONT
6	706252	BACK PANEL DOUBLE DECK
7	715090	SHELF BRACKET R-PLATED
8	706289	TOP SHELF S/S 36"
9	706304	LOWER SHELF S/S 36"
10	763698	RIGHT SIDE STAINLESS PLANT ON
11	763699	LEFT SIDE STAINLESS PLANT ON
12	706391	LEFT OVEN POST COVER, PAINTED
13	706393	LEFT OVEN POST COVER, STAINLESS
14	706114	OVEN CONTROL PANEL, PAINTED
15	706115	OVEN CONTROL PANEL, STAINLESS
16	706116	OVEN CONTROL PANEL INSERT, PAINTED
17	751607	OVEN CONTROL PANEL INSERT, PAINTED - KF
18	706117	OVEN CONTROL PANEL INSERT, STAINLESS
19	751608	OVEN CONTROL PANEL INSERT, STAINLESS - KFS
20	706129	MANIFOLD COVER 36" S/S
21	706361	MANIFOLD COVER 24" S/S
22	706359	MANIFOLD COVER 18" S/S
23	706357	MANIFOLD COVER 12" S/S
24	706163	BURNER BOX PANEL (KICK PLATE), PAINTED
25	706164	BURNER BOX PANEL (KICK PLATE), STAINLESS
26	788382A1	ROLL FRONT/BULL NOSE 12"
27	788382A2	ROLL FRONT/BULL NOSE 18"
28	788382A3	ROLL FRONT/BULL NOSE 24"
29	788382A	ROLL FRONT/BULL NOSE 36"

Riser Kit Without Shelf P/N 788266A

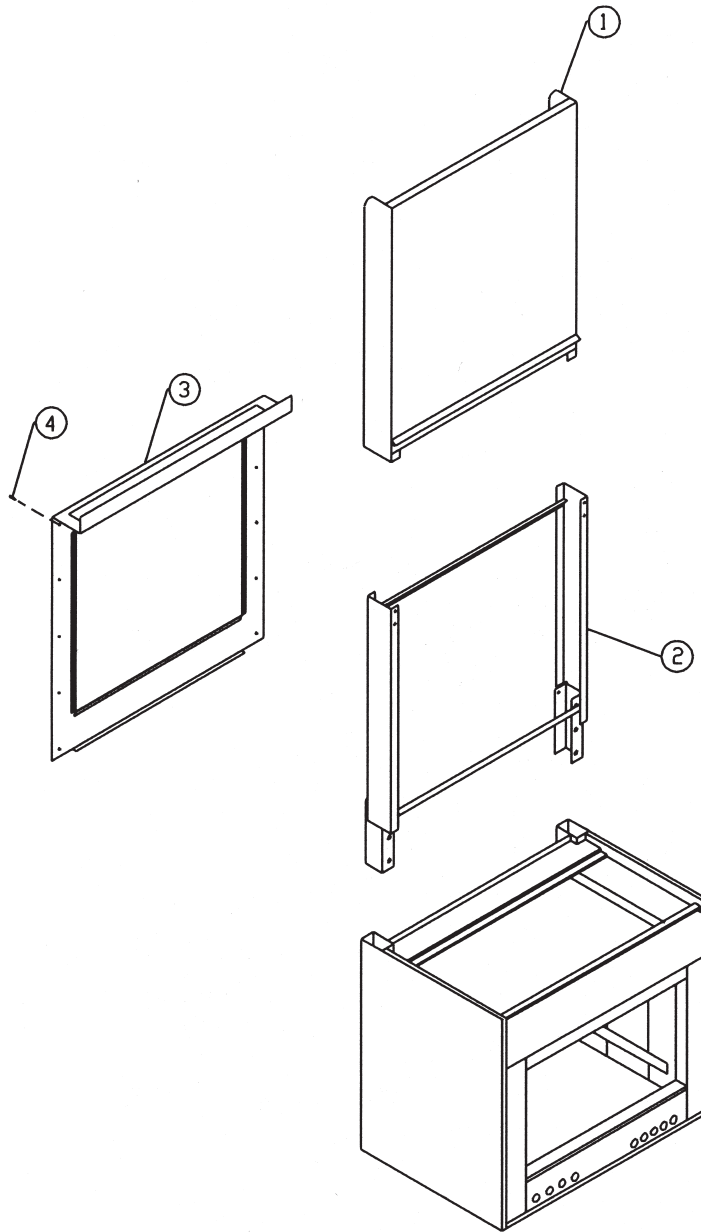

ITEM	QTY	P/N	DESCRIPTION
1	1	767548A	SINGLE DECK RISER PANEL, SST
2	1	707960A	SUPERSTRUCTURE SINGLE DECK ASSY
3	1	707514A	BACK PANEL SINGLE DECK ASSY
4	14	730228	SCREW, 10-24 X 1/2 PHIL

PCN 11267



Riser Kit With Single Shelf P/N 788365A

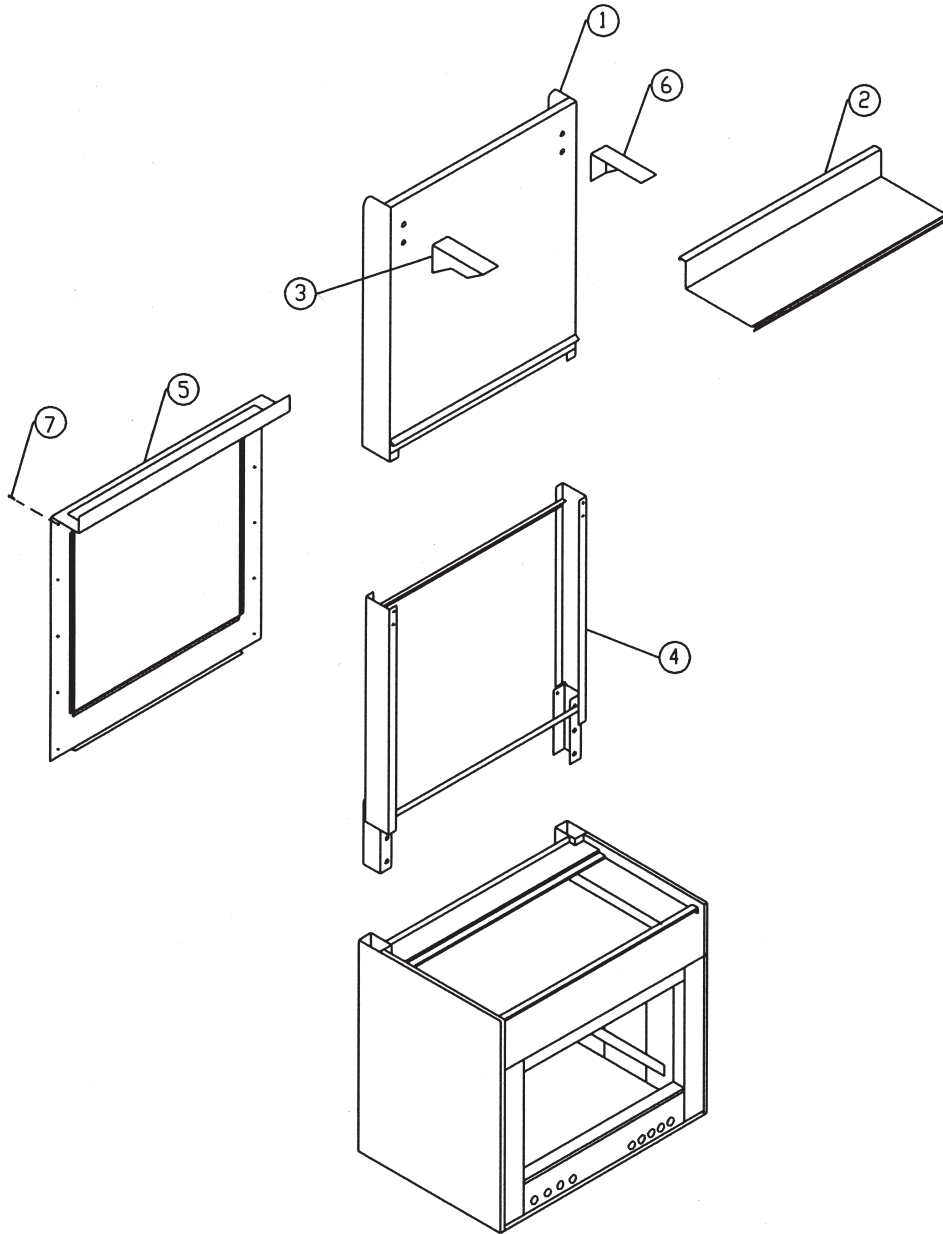

ITEM	QTY	P/N	DESCRIPTION
1	1	767547A	SINGLE DECK HI SHELF PANEL, SST
2	1	706289	TOP SHELF S/S 36"
3	1	715089	SHELF BRACKET L-PLATED
4	1	707960A	SUPERSTRUCTURE SINGLE DECK ASSY
5	1	707514A	BACK PANEL SINGLE DECK ASSY
6	1	715090	SHELF BRACKET R-PLATED
7	14	730228	SCREW, 10-24 X 1/2 PHIL

PCN 11267

Double Deck Riser Kit Without Shelves P/N 788368A

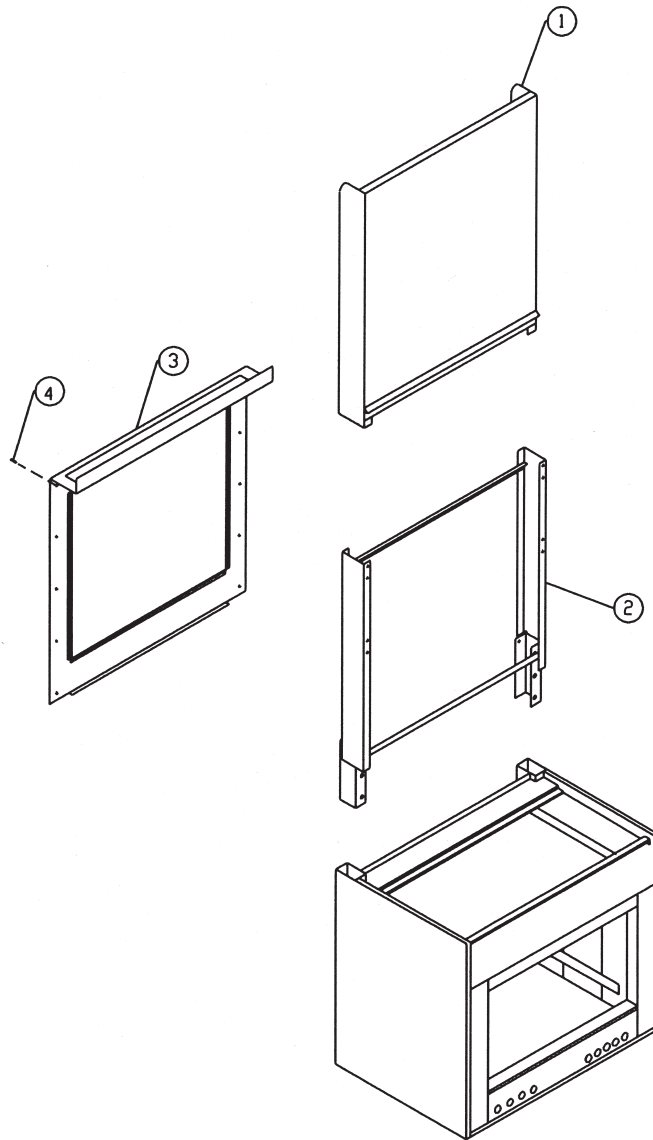

ITEM	QTY	P/N	DESCRIPTION
1	1	767580A	DOUBLE DECK RISER PANEL, SST
2	1	707964A	SUPERSTRUCTURE DOUBLE DECK ASSY
3	1	707519A	BACK PANEL DOUBLE DECK ASSY
4	16	730228	SCREW, 10-24 X 1/2 PHIL

PCN 11267

Double Deck Riser Kit With Shelves P/N 788368A

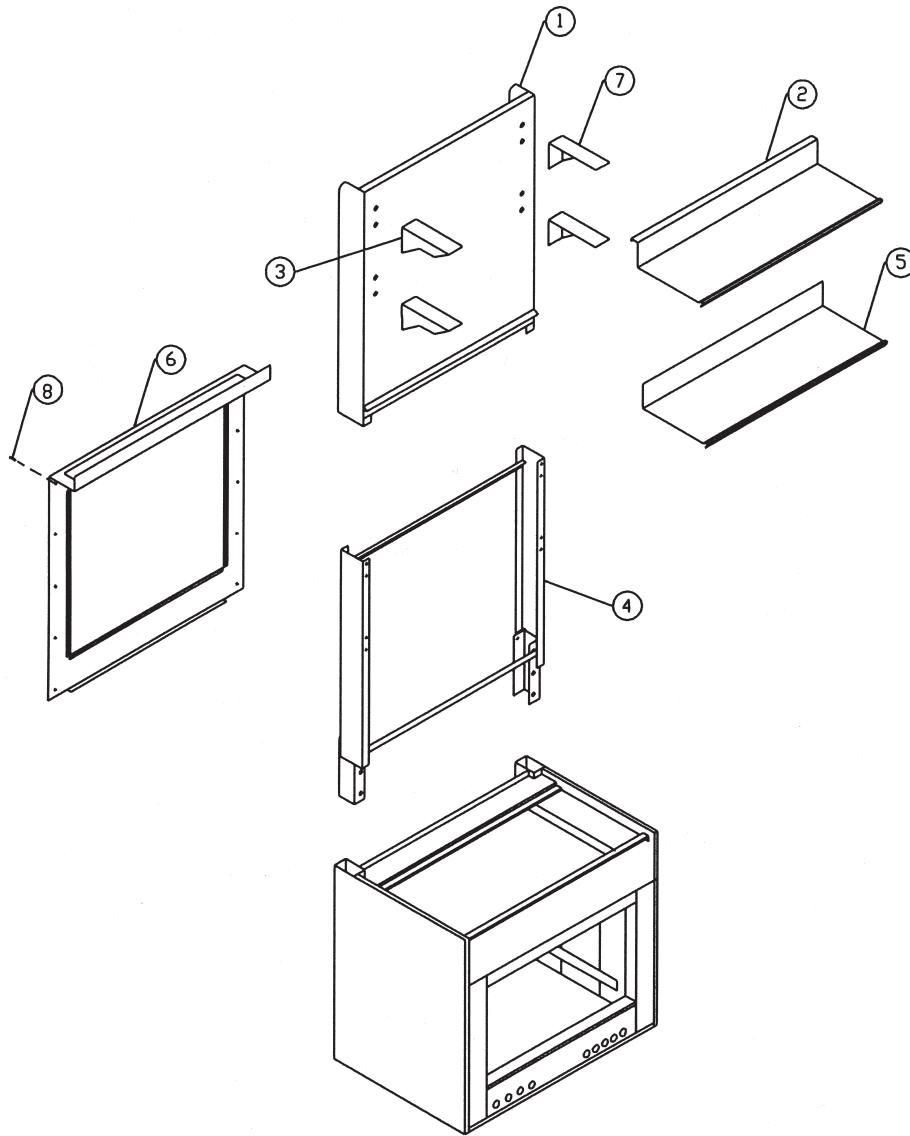

ITEM	QTY	P/N	DESCRIPTION
1	1	767579A	DOUBLE DECK HI-SHELF PANEL, SST
2	1	706289	TOP SHELF S/S 36"
3	2	715089	SHELF BRACKET L-PLATED
4	1	707964A	SUPERSTRUCTURE DOUBLE DECK ASSY
5	1	706304	LOWER SHELF S/S 36"
6	1	707519A	BACK PANEL DOUBLE DECK ASSY
7	2	715090	SHELF BRACKET R-PLATED
8	16	730228	SCREW, 10-24 X 1/2 PHIL

PCN 11267

# NOTES