



**Designer Select Built-In Electric  
27"/30"W. Single/Double Oven**

**Standard Features & Accessories**

**All Designer Select ovens include**

- Overall capacity (each oven)
  - 27"W. models—4.2 cu. ft.
    - 22-5/16"W. x 16-1/2"H. x 19-1/2"D.
  - 30"W. models—4.7 cu. ft.
    - 25-5/16"W. x 16-1/2"H. x 19-1/2"D.
- AHAM\* standard capacity (each oven)
  - 27"W. models—3.6 cu. ft.
    - 22-5/16"W. x 16-1/2"H. x 16-13/16"D.
  - 30"W. models—4.1 cu. ft.
    - 25-5/16"W. x 16-1/2"H. x 16-13/16"D.
- **Exclusive**—largest, self-cleaning convection oven(s) available
- **Exclusive**—patent-pending Vari-Speed Dual Flow™ convection system; 8-1/2" diameter two-speed fan (largest in the industry) works bi-directionally for optimal airflow
- **Exclusive**—Rapid Ready™ system provides super-fast preheating
- 10-pass broiler with heat reflector directs heat directly into food for quicker results
- Concealed 10-pass dual bake element makes the oven cavity easy to clean while providing precise temperature control
- Commercial-type performance
- Ergonomically designed handle for superior feel
  - Durable stainless-steel control knobs
    - Soft-touch, slip-proof rubber grips for easy handling
- Digital clock
  - 100-minute timer
  - Timed Bake feature
    - Set oven to begin cooking up to 24 hours
    - Shuts off when cooking time is complete
- Self-clean setting with indicator light
- High-density insulation contains heat for maximum energy savings, even during high-temperature self-cleaning
- Three heavy-duty, porcelain-coated racks/six rack positions (per oven)
- Includes heavy-duty broiler pan and tray for better broiling performance
- Halogen lighting
- High-performance cooking modes
  - Convection (convection features in top oven only on double ovens)
    - TruConvec™ Convection Cooking

(Viking's exclusive air circulation system uses only a convection element in the rear of the oven with fan-forced air—no direct heat from the top or bottom)

- Convection roast
- Convection bake
- Convection broil
- Convection dehydrate
- Convection defrost
- Conventional
  - Bake
  - Three-level broil
    - High
    - Medium
    - Low

**Designer Select model numbers**

- DESO127—27"W. single oven
- DEDO127—27"W. double oven
- DESO130—30"W. single oven
- DEDO130—30"W. double oven

\*The AHAM Standard for measuring oven capacity subtracts the door plug and convection baffle dimension from the total oven volume.

**Model Options**



**DESO127/130  
Designer Select  
Single Oven**



**DEDO127/130  
Designer Select  
Double Oven**

**FINISH DETAILS FOR SELECT MODELS**

- Stainless Steel (SS), Black (BK), and White (WH)
  - Finish designates door(s) and control panel(s). Stainless steel handles(s), knobs, and buttons, with black knob grips.
- White (WH)
  - Finish designates door(s) and control panel(s). Stainless steel handles(s), knobs, and buttons, with gray knob grips.
- Brass Trim Option (BR)—handle(s), knobs, and buttons. Brass components have a durable protective coating for maintenance-free normal use.

**ORDERING INSTRUCTIONS**

First specify model number, and then color code (DESO127SS). If ordering optional brass trim, specify code at end (DESO127SSBR).



## Designer Premiere Built-In Electric 27"/30"W. Single/Double Oven

### Standard Features & Accessories

#### All Designer Premiere ovens include

- Overall capacity (each oven)
  - 27"W. models—4.2 cu. ft.
    - 22-5/16"W. x 16-1/2"H. x 19-1/2"D.
  - 30"W. models—4.7 cu. ft.
    - 25-5/16"W. x 16-1/2"H. x 19-1/2"D.
- AHAM\* standard capacity (each oven)
  - 27"W. models—3.6 cu. ft.
    - 22-5/16"W. x 16-1/2"H. x 16-13/16"D.
  - 30"W. models—4.1 cu. ft.
    - 25-5/16"W. x 16-1/2"H. x 16-13/16"D.
- **Exclusive** TimePiece™—this precision instrument, which has won multiple prestigious design awards, marks time in both digital and analog modes, helping you observe baking/broiling times for juicy roasts, perfect soufflés, and warm loaves of bread.
- **Exclusive**—largest, self-cleaning convection oven(s) available
- **Exclusive**—patent-pending Vari-Speed Dual Flow™ convection system; 8-1/2" diameter two-speed fan (largest in the industry) works bi-directionally for optimal airflow
- **Exclusive**—Rapid Ready™ system provides super-fast preheating
- Extra-large Gourmet-Glo™ glass enclosed infrared broiler provides superior broiling performance and maximum coverage. Intense heat from this restaurant-quality broiler sears meats and fish, locking in savory juices.
- Concealed 10-pass dual bake element makes the oven cavity easy to clean while providing precise temperature control
- Commercial-type performance
- Large, easy-to-read knobs and bezels
- Ergonomically designed handle for superior feel
- Durable stainless-steel control knobs
  - Soft-touch, slip-proof rubber grips for easy handling
- Digital clock
  - 100-minute timer
  - Timed Bake feature
    - Set oven to begin cooking up to 24 hours
    - Shuts off when cooking time is complete
- Self-clean setting with indicator light
- High-density insulation contains heat for maximum energy savings, even during high-temperature self-cleaning
- Three heavy-duty, porcelain-coated racks/six rack positions (per oven)
- Includes heavy-duty broiler pan and tray for better broiling performance
- Three strategically located halogen oven lights
- High-performance cooking modes
  - Convection (convection features in both upper and lower oven of double ovens)
    - TruConvec™ Convection Cooking (Viking's exclusive air circulation system uses only a convection element in the rear of the oven with fan-forced air—no direct heat from the top or bottom)
  - Convection roast
  - Convection bake
  - Convection broil
  - Convection dehydrate
  - Convection defrost
- Conventional
  - Bake
  - Three-level broil
    - High
    - Medium
    - Low
- ProFlow™ Convection Baffle system—engineered to optimize even heat circulation
- Meat probe offers perfect baking/roasting of fine meats (upper oven in double ovens)
  - Timer sounds and oven shuts off when desired temp is reached
- Includes one TruGlide™ full-extension rack (in each oven cavity of double ovens), which allows easy access (additional racks available for purchase—see **Installation Notes & Accessories**)

#### Designer Premiere model numbers

- DESO527—27"W. single oven
- DEDO527—27"W. double oven
- DESO530—30"W. single oven
- DEDO530—30"W. double oven

\*The Association of Home Appliance Manufacturers (AHAM) standard for measuring oven capacity subtracts the door plug and convection baffle dimension from the total oven volume.

### Model Options



**DESO527/530**  
Designer Premiere  
Single Oven



**DEDO527/530**  
Designer Premiere  
Double Oven

#### FINISH DETAILS FOR PREMIERE MODELS

- Stainless Steel (SS), Black (BK), White (WH), Metallic Silver (MS), Graphite Gray (GG), Stone Gray (SG), Taupe (TP), Biscuit (BT), Cotton White (CW), Oyster Gray (OG), Golden Mist (GM), Lemonade (LE), Sage (SA), Mint Julep (MJ), Sea Glass (SE), Iridescent Blue (IB), Viking Blue (VB), Pumpkin (PM),
- Racing Red (RR), Apple Red (AR), Burgundy (BU), Plum (PL), Chocolate (CH), and Cobalt Blue (CB).
  - Finish designates door(s) and control panel(s). Stainless steel handles(s), knobs, and buttons, with black knob grips.
- White (WH)
  - Finish designates door(s) and control panel(s). Stainless steel handles(s), knobs, and buttons, with gray knob grips.
- Brass Trim Option (BR)—handle(s), knobs, and buttons. Brass components have a durable protective coating for maintenance-free normal use.

#### ORDERING INSTRUCTIONS

First specify model number, and then color code (DESO127SS). If ordering optional brass trim, specify code at end (DESO127SSBR).



**Designer Select & Premiere Built-In Electric  
27"/30"W. Single/Double Oven**

★ Please see  
Installation Notes  
and Accessories for  
important installation  
information, including  
oven racks.



Star-K Kosher  
certification for use  
on the Jewish  
Sabbath or Jewish  
holidays

**Dimensions & Specifications**

**PRODUCT DIMENSIONS & DOOR SWING**



**DESO127/130  
Designer Select  
Single Oven**

**DEDO127/130  
Designer Select  
Double Oven**

**DESO527/530  
Designer Premiere  
Single Oven**

**DEDO527/530  
Designer Premiere  
Double Oven**

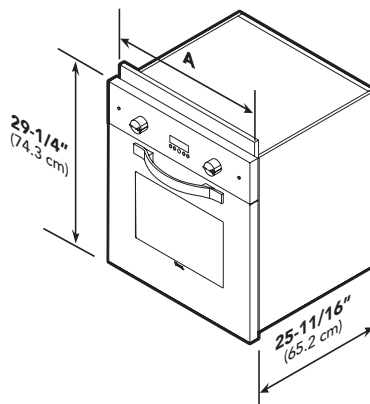

**DESO**

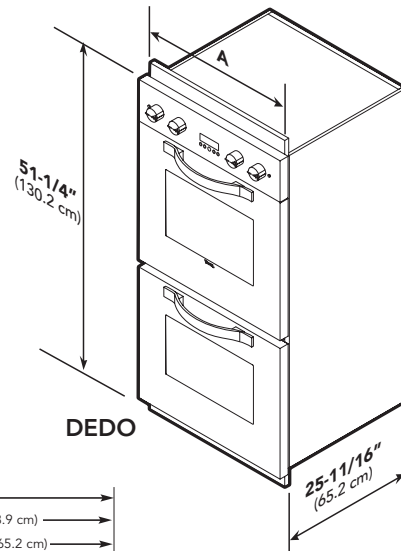

**DEDO**

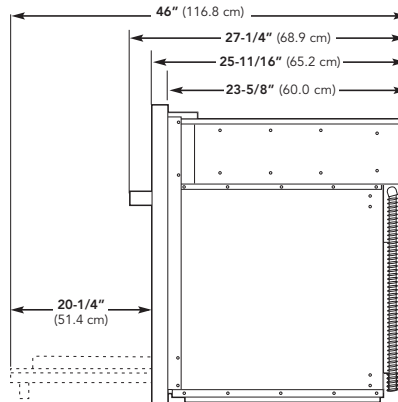

**DESO/DEDO**

	<b>DESO127/527</b>	<b>DEDO127/527</b>	<b>DESO130/530</b>	<b>DEDO130/530</b>
Overall width (A)	26-1/2" (67.3 cm)	26-1/2" (67.3 cm)	29-1/2" (74.9 cm)	29-1/2" (74.9 cm)
Overall height (from bottom)	29-1/4" (74.3 cm)	51-1/4" (130.2 cm)	29-1/4" (74.3 cm)	51-1/4" (130.2 cm)
Overall depth (from rear)				
To edge of door		<b>25-11/16" (65.2 cm)</b>		
With door open		<b>46" (116.8 cm)</b>		
Interior (each oven)				
Width	22-5/16" (56.7 cm)	22-5/16" (56.7 cm)	25-5/16" (64.3 cm)	25-5/16" (64.6 cm)
Height			<b>16-1/2" (41.9 cm)</b>	
Depth			<b>16-13/16" (42.7 cm)</b>	
Approx. ship weight	258 lbs. (117.6 kg)/ 273 lbs. (123.8 kg)	384 lbs. (174.2 kg)/ 409 lbs. (185.5 kg)	278 lbs. (126.1 kg)/ 293 lbs. (132.9 kg)	424 lbs. (192.3kg)/ 449 lbs. (203.7 kg)



**Designer Select & Premiere Built-In Electric  
27"/30"W. Single/Double Oven**

**Installation Requirements**

**UTILITY  
REQUIREMENTS**



**GAS**

- Not applicable



**ELECTRICAL**

- Five-foot flexible steel conduit included. Equipped with No.10 ground wire in unit. Fuse separately.
  - o Four-wire with ground
  - o 240 – 208/120 V/60 Hz
  - o 30 amp electrical connection for singles
  - o 50-amp electrical connection for doubles
- Max. amp usage—(240V/208V)
  - o Single—24.0/20.8
  - o Double—40.0/34.7



**PLUMBING**

Not applicable

**ACCESS REQUIREMENTS**

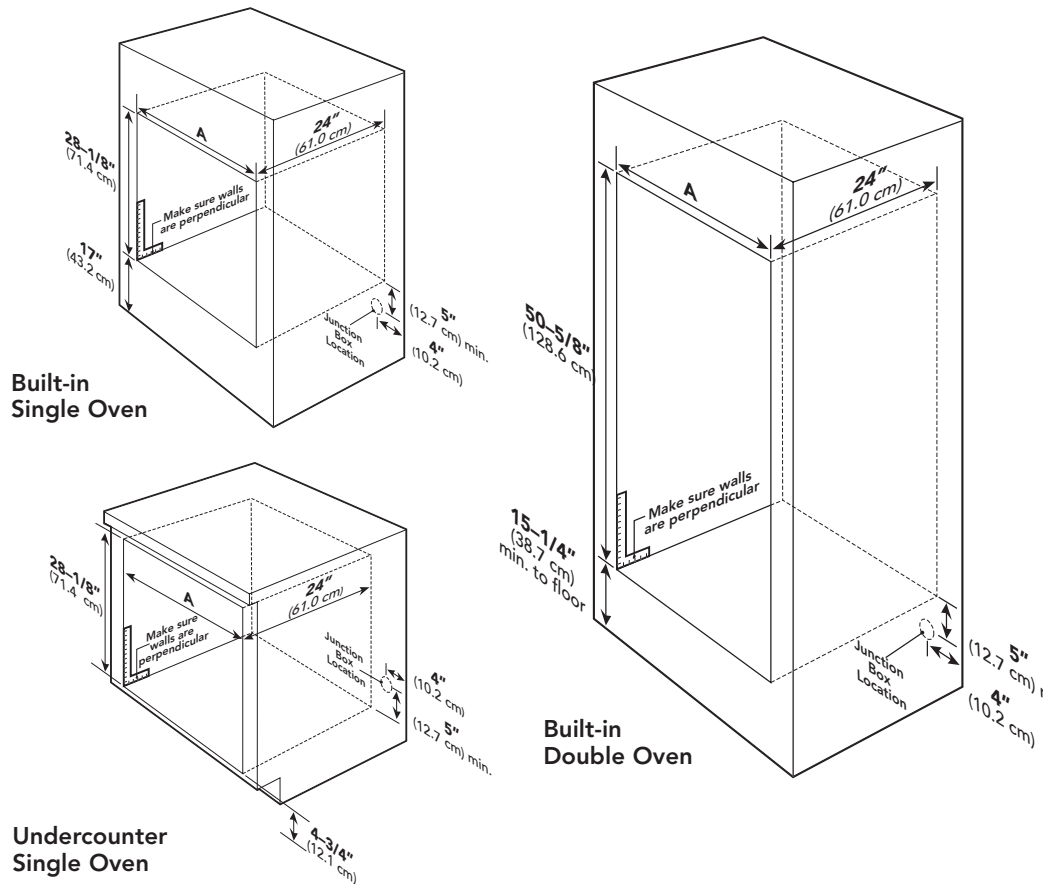

	<b>DESO127/527</b>	<b>DEDO127/527</b>	<b>DESO130/530</b>	<b>DEDO130/530</b>
Cutout width (A)	<b>25-1/2" (64.8 cm)</b>	<b>25-1/2" (64.8 cm)</b>	<b>28-1/2" (72.4 cm)</b>	<b>28-1/2" (72.4 cm)</b>
Cutout height (from bottom)	28-1/8" (71.4 cm)	50-5/8" (128.6 cm)	28-1/8" (71.4 cm)	50-5/8" (128.6 cm)
Cutout depth	<b>24" (61.0 cm)</b>			



**Designer Select & Premiere Built-In Electric  
27"/30"W. Single/Double Oven**

**✪ Installation Notes & Accessories**

**TruGlide™ Full Extension Oven Racks**

- For Professional and Designer Premiere/Select models
- Heavy-duty chrome-plated racks match regular racks shipped with ovens
- Fits securely on rack supports and fully extends, making it easier to load and unload oven
- Can be used in any of the six oven rack positions
- Single rack

Model	Description	Approx. ship wt. lbs. (kg)
TESO27	TruGlide™ rack (27"W.)	13 (5.9)
TESO30	TruGlide™ rack (30"W.)	15 (6.8)

**Hearth Stone**

- Hard-fired ceramic baking stone
- Absorbs heat and sends it back into food during cooking
- Can be used in all Viking Select and Premiere ovens

Model	Description	Approx. ship wt. lbs. (kg)
OHS18	17-5/8"W. x 13"D. hearth stone	13 (5.9)

**V-rack & Drip Pan**

- No stick V-rack can be used for cooking roasts, hams, ribs, etc.
- Drip pan catches drippings from items cooked in V-rack to generate flavor and prevent flare-ups

Model	Description	Approx. ship wt. lbs. (kg)
CVD	V-rack and drip pan	4 (1.8)

**Broiler Pan & Tray**

- For use with all Viking built-in and range ovens
- Heavy-duty porcelainized construction
- Tray allows drippings to fall through to broiler pan
- Tray is removable for easy cleaning

Model	Description	Approx. ship wt. lbs. (kg)
BPT	Broiler pan and tray	5.5 (2.5)

**Broiler Pan Rack**

- For use with Viking broiler pans
- Provides better broiling and roasting options in convection modes

Model	Description	Approx. ship wt. lbs. (kg)
BPR	Broiler pan rack	1 (0.45)

**Compliance Information**



**WARRANTY INFORMATION\***

- One-year full warranty—complete product
- Five-year limited warranty—all oven elements
- Ten-year limited warranty—porcelain oven(s) and porcelain inner door panel
- Ninety-day limited warranty—cosmetic parts such as glass, painted, and decorative items

\* For complete warranty see *Use & Care Guide*. Warranty valid on Viking products shipped within the United States and Canada.