



OPERATING AND INSTALLATION INSTRUCTIONS

MODEL NO.
E 750

IMPORTANT SAFETY INFORMATION

These warnings are provided in the interests of your safety. Ensure that you understand them all before installing or using the cooker. Your safety is of paramount importance. If you are unsure about any of the meanings of these warnings contact the Customer Care Department. The address is on the back page of this book.

INSTALLATION

- The cooker must be installed according to the instructions supplied. Any electrical installation work must be undertaken by a qualified electrician/competent person.
- This cooker is heavy and care must be taken when moving it. Do not try to move the cooker by pulling the door handles.
- All packaging, both inside and outside the cooker must be removed before the cooker is used.
- It is dangerous to alter the specifications or modify the cooker in any way. After installation please dispose of the packaging with due regard for safety and the environment.

CHILD SAFETY

- This cooker is designed to be operated by adults. Young children must not be allowed to tamper with the controls or play near or with the cooker.
- The cooker and accessible parts especially around the grill area become hot when the cooker is in use. Keep children away until it has cooled.

DURING USE

- Do not use this cooker if it is in contact with water. Never operate it with wet hands.
- Take great care when heating fats and oils as they will ignite if they become too hot.
- This cooker has been designed for cooking edible foodstuffs only, and must not be used for any other purposes.
- Never place plastic or any other material which may melt in or on the oven.
- Do not leave the grill pan handle in position when grilling and ensure oven gloves are used to remove and replace the handle, as it will become hot.
- Always use oven gloves to remove and place food in the oven.
- Ensure that all vents are left unobstructed to ensure ventilation of the oven cavity.
- Never line any part of the cooker with aluminium foil. Do not allow heatproof cooking material, e.g. roasting bags to come into contact with oven elements because they may catch fire.
- Always stand back from the cooker when opening the oven door to allow any build up of steam or heat to release.

- Stand clear when opening the drop down oven doors. Support the doors using the handles until fully open.
- Do not place sealed cans or aerosols inside the oven. They may explode if they are heated.
- Ensure that all control knobs are in the OFF position when not in use.
- Do not stand on the cooker or on the open oven doors.
- Do not hang towels, dishcloths or clothes from the cooker or its handles. They are a safety hazard.

CLEANING AND MAINTENANCE

- The cooker is heavy and care must be taken when moving it.
- This cooker should be kept clean at all times. A build-up of fats or other foodstuffs could result in a fire, especially in the grill pan.
- Do not leave cookware containing foodstuffs, e.g. fat or oil in the cooker in case it is inadvertently switched on.
- Always allow the cooling fan to cool the cooker down before switching off at the wall prior to carrying out any cleaning / maintenance work.
- Only clean this cooker in accordance with the instructions given in this book.

SERVICE

- Repairs should not be carried out by inexperienced persons as this may cause injury or serious malfunction. This cooker should be serviced by an authorised Service Engineer and only genuine approved spare parts should be used. Details of servicing and repair arrangements are supplied on page 44 of this book.

AT THE END OF THE COOKERS LIFE

- When the time comes to dispose of your cooker please contact your local Council Authority. They can arrange to dispose of the cooker in a safe and controlled manner. The number will be in the telephone book.



Please read this instruction book carefully before use and retain for future reference.

CONTENTS

FOR THE USER

Important Safety Information	2	The Main Fan Oven	29
Description of the cooker	5	Uses of The Fan Oven	29
Getting to Know Your Oven	6	How To Use the Fan Oven	29
The Cooling Fan for the Controls	7	Things to Note	29
Control Panel Indicator Neons	7	To Fit the Fan Oven Shelves	30
Before Using The Cooker	8	Hints and Tips	30
Rating Plate	8	Fan Oven Cooking Chart	31
When First Switching On	8	Roasting Chart	32
The Fan Selector Button	8	Defrosting in the Main Fan Oven	33
Condensation and Steam	8	Uses of Defrost Feature	33
Cookware	9	How to Defrost	33
The Trivet	9	Things to Note	33
Grill and Oven Furniture	10	Hints and Tips	33
The Electronic Timer	11	Care and Cleaning	35
The Dual Grill	15	Cleaning Materials	35
Uses of the Grill	15	Cleaning the Outside of the Cooker	35
How To Use the Dual Grill	15	Cleaning the Outer and Inner Door	36
Things To Note	15	Glass Panels	36
The Grill Pan and Handle	16	Cleaning Inside the Ovens	37
Hints and Tips	16	To Remove the Wirework Runners	38
Grilling Chart	18	Cleaning the Shelves, Wirework Runners and Oven Furniture	38
The Fan Assisted Convenience Oven	19	Care of Stayclean Surfaces	38
Uses of the Fan Assisted Oven	19	The Oven Cleaning Cycle	39
How To Use the Fan Assisted Oven	19	Things to Note	39
Things To Note	19	Hints and Tips	39
To Fit the Oven Shelves	19	Replacing the Oven Light Bulb	40
Hints and Tips	20	If Something Doesn't Work	41
The Conventional Convenience Oven	21	Guarantee Conditions	43
Uses of the Conventional Oven	21	Service and Spare Parts	44
How To Use the Conventional Oven	21	Customer Service Centres	45
Things to Note	21		
To Fit the Oven Shelf	21		
Hints and Tips	22		
Convenience Oven Cooking Chart	23		
Thermal Grilling in the Convenience Oven	24		
Uses of Thermal Grilling	24		
How To Thermal Grill	24		
Things to Note	25		
Hints and Tips	25		
Thermal Grilling Chart	26		
To Cool and Defrost in the Convenience Oven	27		
Uses of Cooling and Defrost	27		
How to Cool / Defrost	27		
Things to Note	27		
Hints and Tips	27		

Please read the whole instruction book before using the cooker. To help you the following symbols will be found in the text.

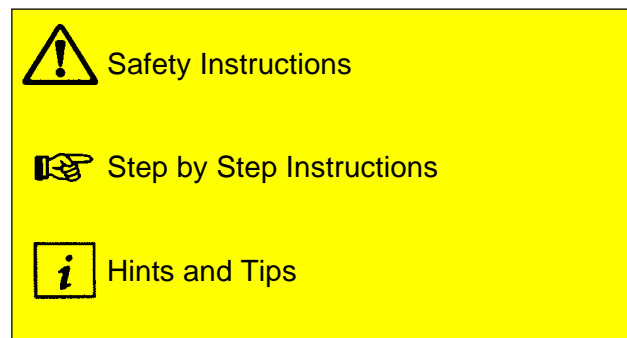

FOR THE INSTALLER

Technical Details	47
Things You Need to Know	48
Warnings	48
Choice of Electrical Connection	48
Things to Note	49
Preparing Cabinet for Fitting Oven	50
How to Finish Unpacking	51
Making the Electrical Connections	52
To Remove Cover of Mains Terminal	52
Connecting to the Mains Terminal	53
Checking Electrical Connections	54
Connecting to a Hob or Cooker Point	54

DESCRIPTION OF THE COOKER

Built in electric double oven



WARNING: THIS COOKER MUST BE EARTHED

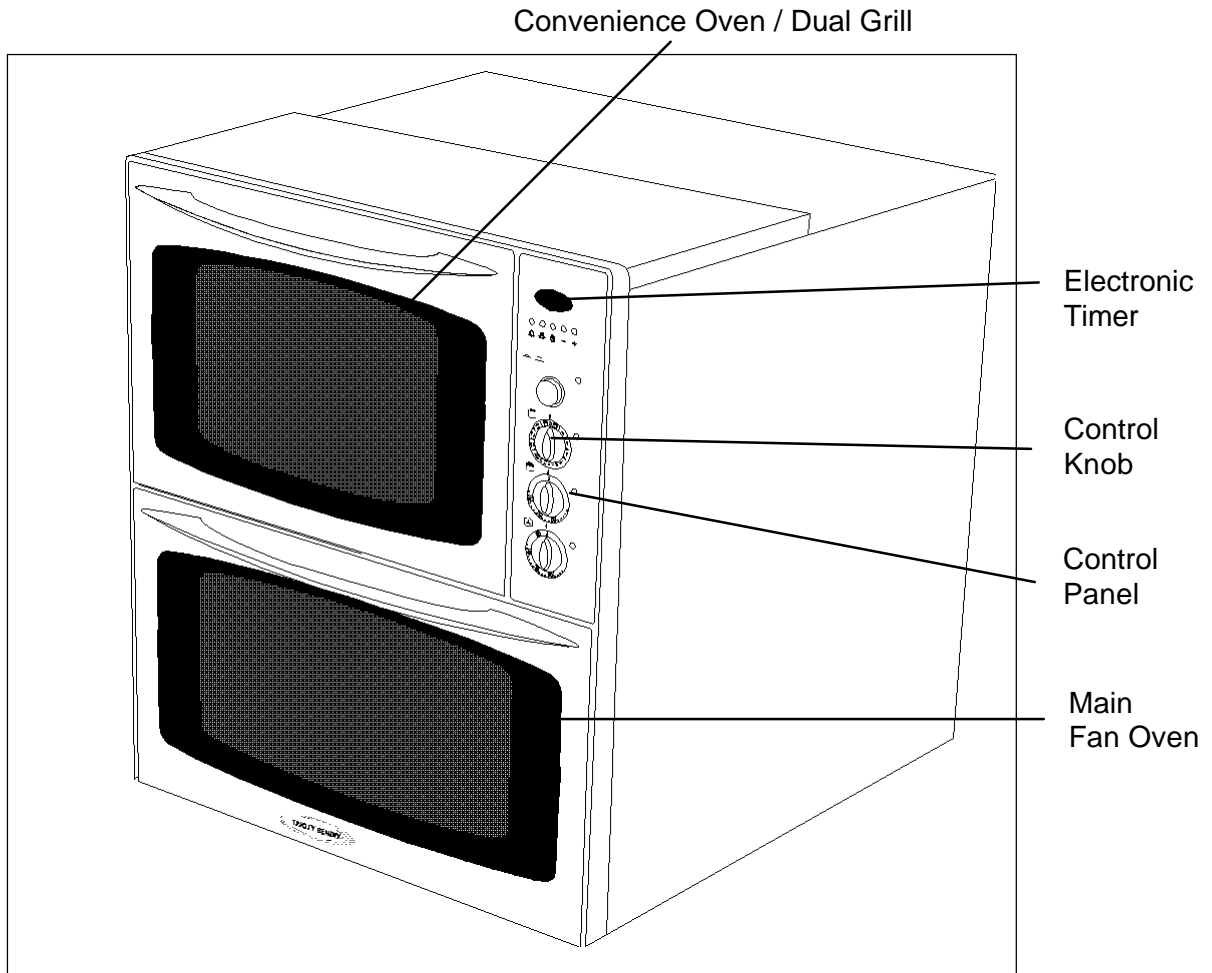

Your built in cooker comprises of an oven with conventional and fan assisted option and dual grill in the top compartment. The top oven is convenient and economical for mid-week use because of its size. The main fan oven is the larger of the two ovens. It is particularly suitable for cooking larger quantities of food.

The main fan oven can be automatically controlled by the electronic timer.

GETTING TO KNOW YOUR OVEN

The Control Panel

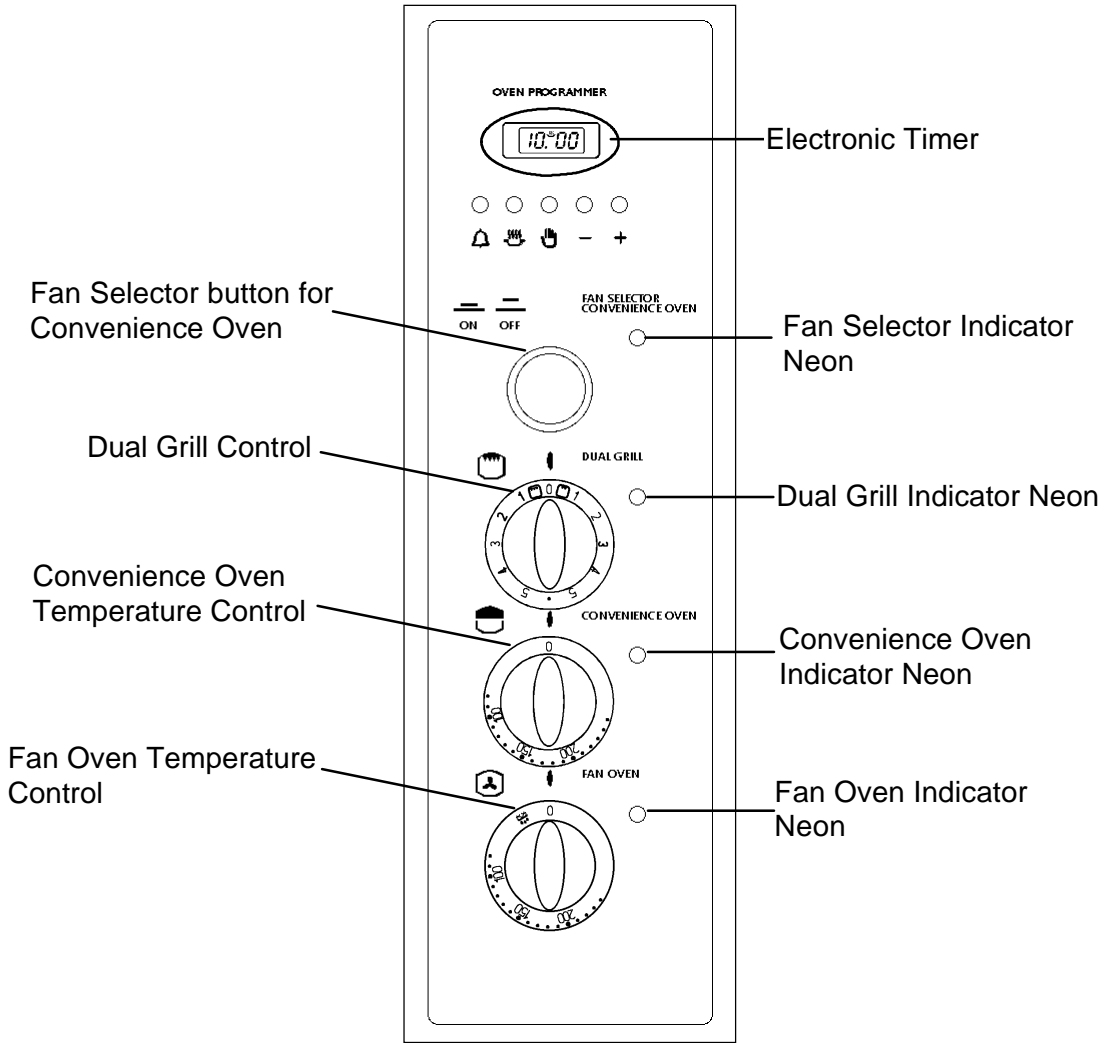

THE COOLING FAN FOR THE CONTROLS

Your cooker has a cooling fan fitted behind the controls to prevent them from overheating.

The cooling fan will come on immediately with the grill or when thermal grill is selected and after a short time when either of the ovens are in use.

The cooling fan may cycle on and off when the cooker is in use. This is quite normal.

The cooling fan may run on after the ovens or grill are switched off for a period of time to cool the cooker down. It may continue to switch on and off until the cooker is cool.



Always allow the cooling fan to cool the cooker down before switching off at the wall prior to carrying out any cleaning or maintenance work.

NOTE

The action of the cooling fan will depend on how long the ovens or grill have been used and at what temperature. It may not switch in at all at lower temperature settings nor run on where the grill or oven has only been used for a short time.

CONTROL PANEL INDICATOR NEONS

These lights indicate whether the ovens or grill are switched on. When the grill or ovens are switched on the neon illuminates. In the case of the ovens, the neons also indicate when the set temperature has been reached. They will cycle on and off during use to show that the temperature is being maintained.

The grill neon does not cycle on and off when the grill is in use.

The Fan oven neon does not operate with the Defrost function.

The Fan Selector neon operates when the Fan Selector button is set. It does not cycle on and off when in use.

The Selector neon will illuminate with all Convenience oven functions, except the conventional oven.

If the neons do not operate as the instructions indicate the controls have been incorrectly set. Return all controls to zero and re-set following the instructions for the required setting.

When the main fan oven has been set for automatic cooking the neon will illuminate when cooking begins.

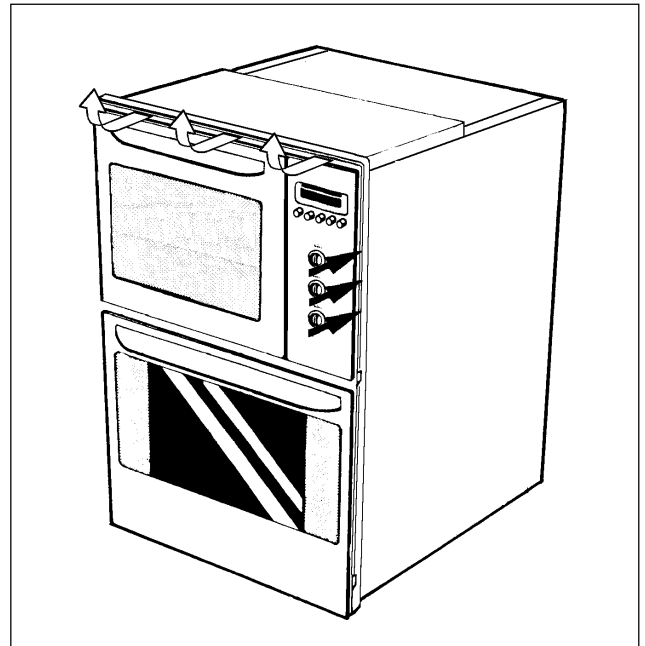

BEFORE USING THE COOKER

WHEN FIRST SWITCHING ON

The timer must be set to manual operation before the main fan oven can be operated. This must be done whenever the cooker is switched off at the wall or when there has been a power failure. For instructions on how to set the timer see page 11.

If the Fan oven indicator neon does not glow when the oven temperature control is turned, it is most likely that the timer is set for automatic cooking.

The Convenience Oven and the Dual Grill are not controlled by the electronic timer.

RATING PLATE

Record the model, product and serial numbers of your cooker on the back page of this instruction book for future reference. You can find these numbers on the rating plate on the front frame of the cooker upon opening the top oven door.

The cooker must be protected by a suitably rated fuse or circuit breaker. The rating of the cooker is given on the rating plate.

PREPARING TO USE YOUR COOKER

Wipe over the base of the ovens with a soft cloth and hot soapy water and wash the grill and oven furniture before use.

The grill and ovens should be heated without food to burn off any residue from the elements. To do this, run the ovens at maximum temperature for approximately 45 minutes. The procedure should be repeated with the grill for approximately 5 - 10 minutes.

During this period an unpleasant odour may be emitted, it is therefore advisable to open a window for ventilation.

THE FAN SELECTOR BUTTON

The Convenience oven enables you to cook with the oven fan in operation or by conventional means. Push the Fan Selector button in for fan assisted cooking. Push the button out for conventional oven cooking. Refer to the appropriate oven section for full instructions.

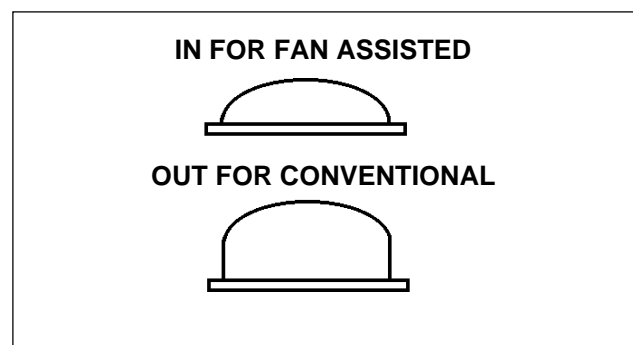
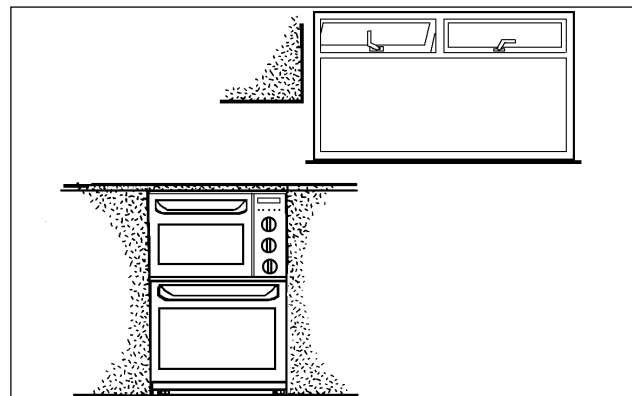
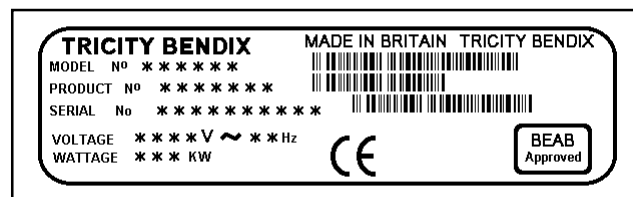
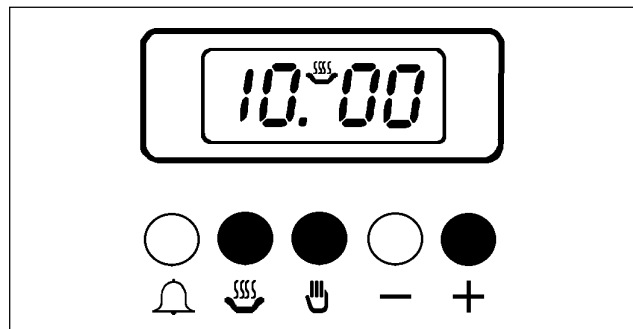

CONDENSATION AND STEAM

When food is heated it produces steam in the same way as a boiling kettle does. The ovens are vented to allow some of this steam to escape. However, always stand back from the cooker when opening the oven doors to allow any build up of steam or heat to release. If the steam comes into contact with a cool surface on the outside of the cooker, e.g. a trim, it will condense and produce water droplets. This is quite normal and is not caused by a fault on the cooker.

To prevent discolouration occurring, regularly wipe away condensation and any soilage from the cooker surfaces.

COOKWARE

Baking trays, dishes etc., should not be placed directly against the grid covering the fan at the back of the oven.

Do not use baking trays larger than 30cm x 35cm (12" x 14") as they will restrict the circulation of heat and may affect performance. Advice on the effect of different materials and finishes of bakeware is given in 'Hints and Tips' in the appropriate oven section.

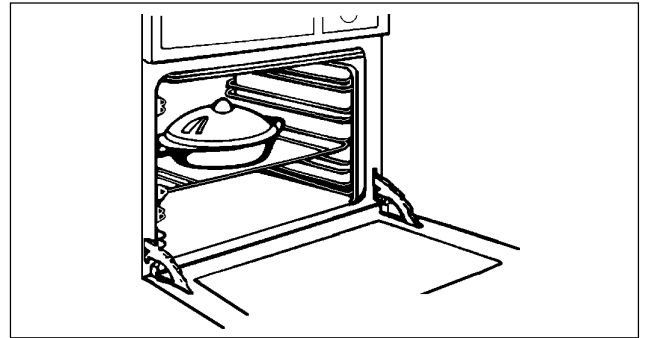

THE TRIVET

When roasting we recommend that you use the trivet in the meat tin. Fat and meat juices will drain into the meat tin below and can be used to make gravy. The trivet also prevents splashes of fat from soiling the oven interior.

Note. The meat tin should not be placed on a heated hotplate as this may cause the enamel to crack.

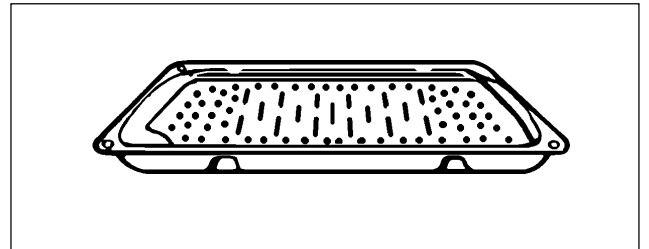

GRILL AND OVEN FURNITURE

The following items of oven furniture have been supplied with the cooker.

1 grill pan



1 grill pan handle

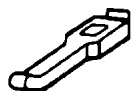

1 grill pan grid

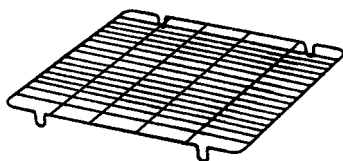

1 trivet

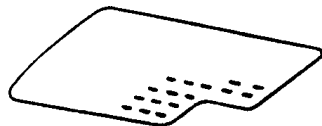

1 meat tin

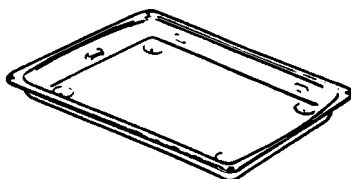

2 shelves for main oven cooking

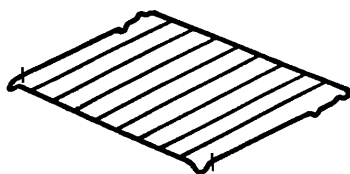

2 shelves for grilling and Convenience oven cooking

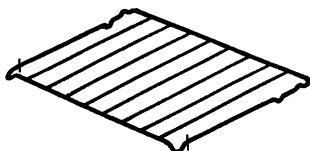



Scuffing of the Stayclean sides and back panel by the oven furniture pack may occur during transit.

These marks will disappear after the oven has been used for the first time.

THE ELECTRONIC TIMER



The electronic timer can indicate the time of day, operate as a minute minder and automatically time the main fan oven.

- A Auto Symbol (automatic cooking)
-  Bell Symbol (minute minder)
-  Cookpot Symbol (manual cooking)

Please note that this is a 24 hour clock, for example 2pm is shown as 14.00.

If the oven is switched off at the wall or there is loss of power the clock will stop and you will not be able to use the cooker. When you first switch the electricity supply on, the timer display will flash.

TO SET THE TIME OF DAY

1. Press buttons  and  together. Release the buttons.
2. Within 5 seconds press the + button until the time of day shows in the display.

The cookpot symbol () will be showing.

TO CHANGE THE TONE OF THE ALARM

The timer has three different tones to the alarm. You can change the sound of the alarm if you wish.

1. Ensure the clock shows the correct time of day.
2. Press the - button to change the sound of the alarm.

You will hear each of the three tones with each press of the button. Keep pressing the button until you hear the tone you prefer.

The next time the minute minder or timer is used the tone you selected will sound.

THE MINUTE MINDER

1. Press and release the  button.
2. Within 5 seconds press the + button until the display shows the time you want.

Our diagram shows the timer set to 5 minutes. After a few seconds the time of day will show in the display.

When you are using the minute minder you can check the number of minutes remaining by pressing the  button.

At the end of the timed period an alarm will sound. Switch off the alarm by pressing the  button.

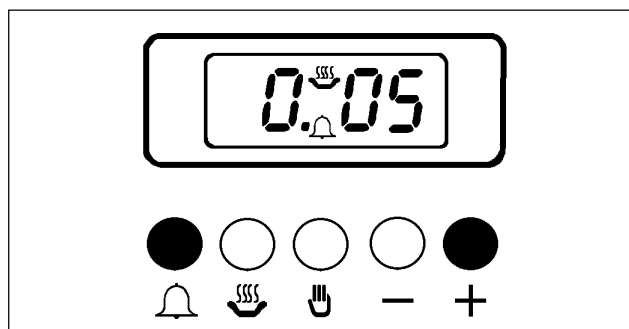
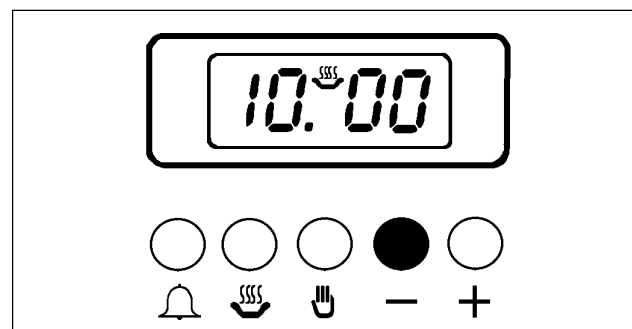
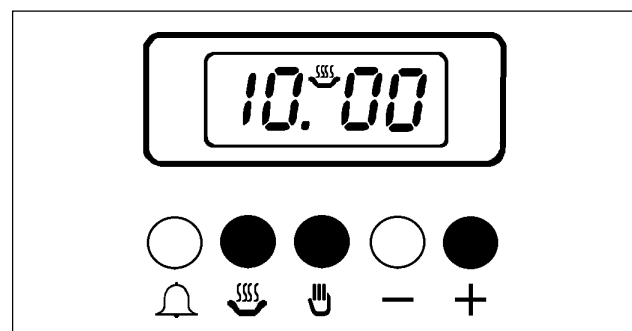
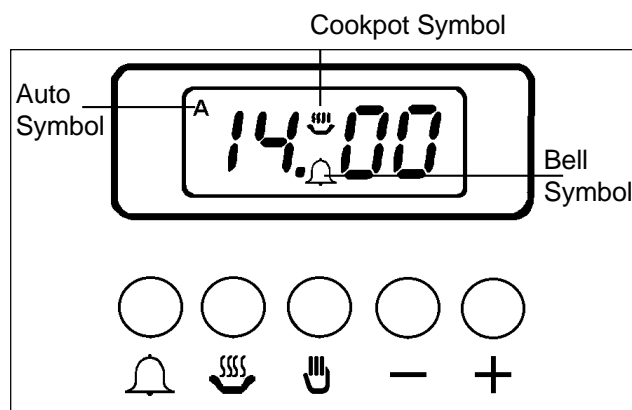

After a few seconds the time of day shows in the display.



AUTOMATIC TIMER CONTROL

The automatic timer can be used with the main fan oven only.

TO SWITCH THE MAIN OVEN ON AND OFF AUTOMATICALLY

1. Ensure the clock is showing the correct time of day.
2. Place food in the main oven.
3. Set the length of time you want the food to cook for by pressing and releasing the  button and then pressing the + button until the correct cooking time is displayed. This must be completed within 5 seconds of pressing the  button.

The maximum cooking time is 23 hours 59 minutes.

The Cookpot and Auto symbols will show in the display. Our diagram shows the cooking time set for 2 hours 30 minutes.

After a few seconds the time of day shows in the display.

4. To set the time you want the food to be cooked by, press and release the  button. This will show you the earliest possible stop time.

If this is different to the time you want the food to be cooked by, press the + button within 5 seconds until the correct stop time shows in the display. Our diagram shows the food is to be cooked by 18.00 hours (6pm).

After a few seconds the time of day shows in the display and the Cookpot symbol goes out.

The 'Stop' time must not be more than 23 hours 59 minutes from the time of day. For example, if the time of day is 09.00 hours (9.00am) the latest 'Stop' time will be 08.59 (8.59am) the next day.

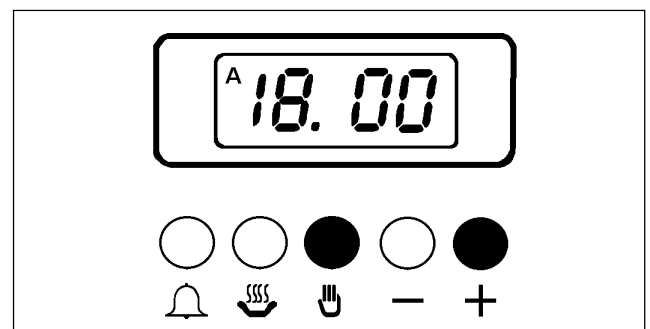
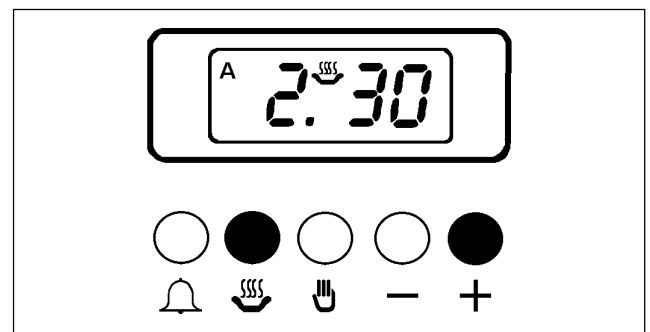



5. Turn the oven control to the correct temperature.

The clock will work out what time the oven will switch itself on and will switch the oven off at the end. An audible signal will sound when cooking is complete. To cancel the alarm, see below.

RETURNING THE COOKER TO MANUAL OR TO CANCEL AN AUTOMATIC PROGRAMME

Once automatic cooking is complete an alarm will sound and the Auto symbol will flash to remind you that the oven needs to be set for manual operation.

1. To do this press buttons  and  together. After a few seconds the timer will show the time of day. The cookpot will show in the display and the oven will switch on again.
2. Turn off the oven control.

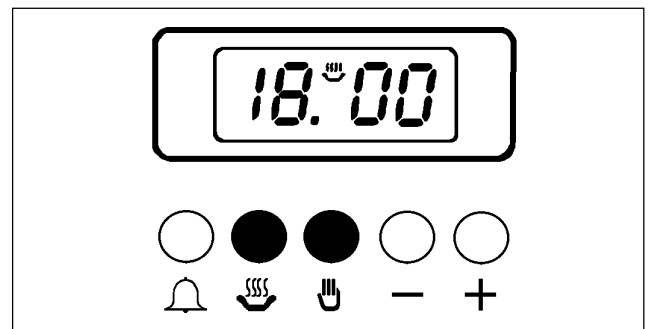

TO SET THE TIMER TO SWITCH OFF ONLY

This is useful if you want to begin cooking immediately but have the main fan oven switch off whilst you are out.

1. Ensure the clock is showing the correct time of day.
2. Place food in the oven.
3. Set the length of time you want the food to cook for. Press and release the  button and then within 5 seconds press the + button until the correct cook time is showing.

Our diagram shows the timer set for 2 hours 30 minutes.



After a few seconds the time of day shows in the display.

4. Turn the oven temperature control to the required setting. The oven indicator neon will come on.

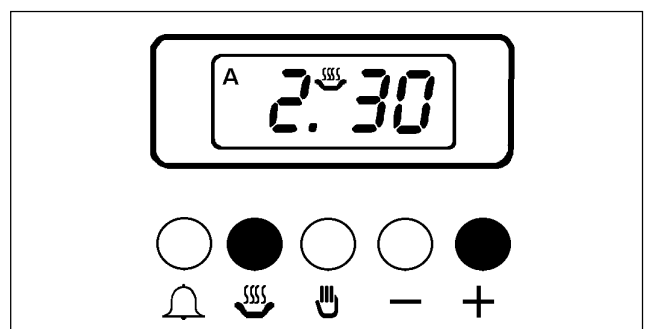
If you want to check the time the oven will switch off simply press the  button and the 'Stop' time will be displayed.



At the end of the cooktime the oven will switch off, the alarm will sound and the auto symbol will flash.

5. To cancel and return to manual operation press buttons  and  together.

6. Turn off the oven temperature control.

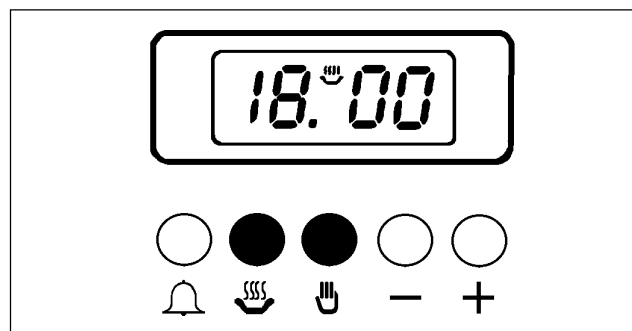

THE DUAL GRILL



WARNING - Accessible parts become hot when the grill is in use. Keep children away.

USES OF THE GRILL

The grill is situated in the Convenience oven compartment.

The grill is a dual circuit grill which means that the full area of the grill or the centre section only can be used. Use the full grill for cooking larger quantities of food. Use the centre section for economy purposes when cooking smaller quantities.



HOW TO USE THE DUAL GRILL

1. Open the Grill / Convenience Oven door.
2. Turn the grill control clockwise for full grill or anticlockwise for the centre section only.
3. Ensure the Convenience Oven control is in the Off position '0'.



The grill door must be left open when grilling.

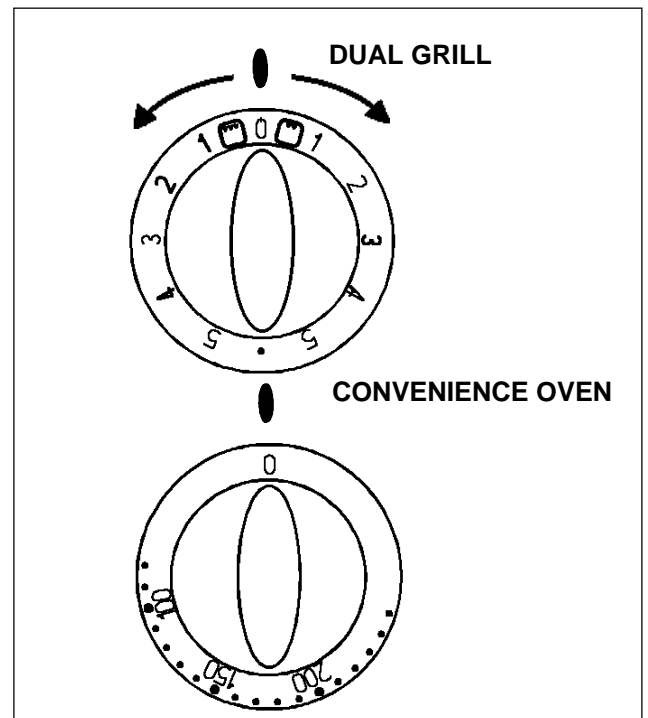

THINGS TO NOTE

- The cooling fan for the controls will operate as soon as the grill control is turned. For more information on the operation of the cooling fan turn to page 7.
- The outer section of the grill element may appear to glow brighter than the inner section. This is quite normal.
- The grill indicator neon will illuminate.
- You can use the grill pan on the shelf in positions 3 and 5 only.
- If you use the grill pan in position 3 the shelf must be withdrawn before the pan can be located or removed.



Ensure the grill pan is properly located.

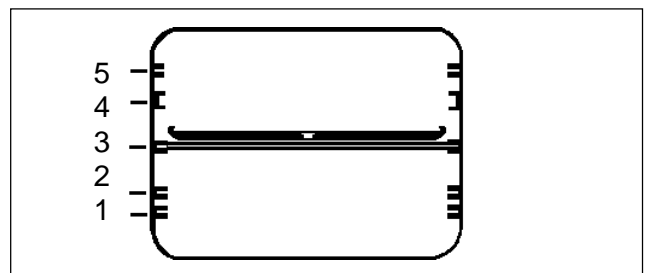

THE GRILL PAN AND HANDLE

The grill pan has a removable handle.

To insert the handle, press the button on the handle with the thumb and pivot the handle slightly upwards inserting the lip into widest part of the bracket. Move the handle towards the left, lower into position and release the button.



Ensure the handle is positively located.

To remove the handle, press the button on the handle with the thumb and pivot the handle slightly upwards and towards the right to remove from the bracket.



Protect your hands when removing the grill pan handle.

Always remove the grill pan handle during grilling.

To correctly locate the grill pan on the shelf, ensure that the cut out on the underside of the handle bracket locates over the front bar of the shelf.

To check the progress of the food being grilled, the grill pan should be withdrawn on the shelf to attend to food during cooking.



Ensure that you support the grill pan when it is withdrawn.



HINTS AND TIPS

- Most foods should be placed on the grilling grid in the grill pan. This allows maximum circulation of air by raising the food out of fats and juices. Foods such as fish, liver and kidneys may be placed directly on the trivet in the grill pan if preferred.
- Adjust the grid and grill pan runner position to allow for different thicknesses of food. Position the food close to the element for faster cooking and further away for more gentle cooking.

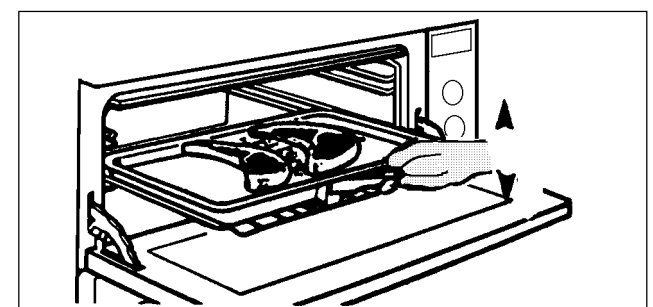
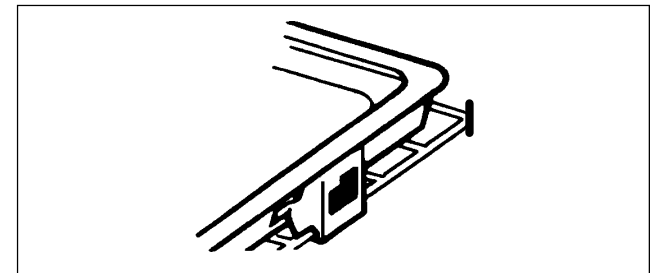
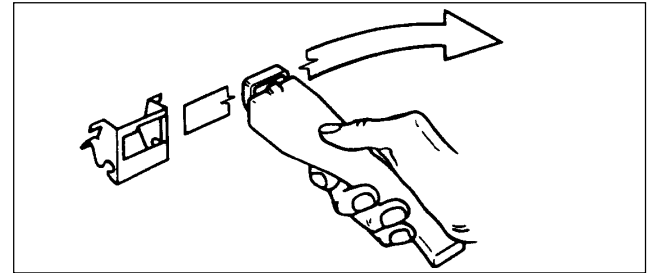
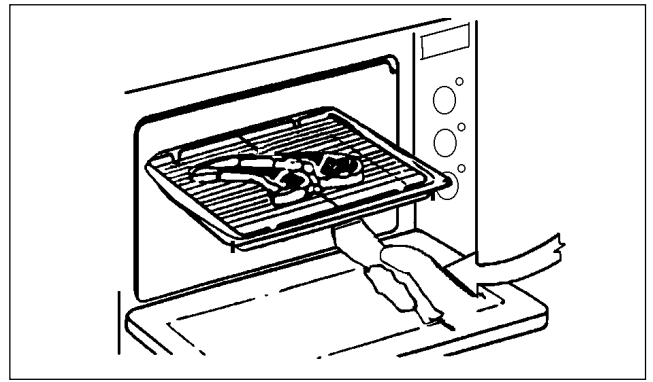

- The grill pan grid is reversible. This is useful if you want to cook foods of varying thickness. As a general rule, bread for toasting should be placed on the grid in the ' high ' position in the grill pan. Foods such as chicken pieces or chops may be grilled using the grilling grid in the low position.

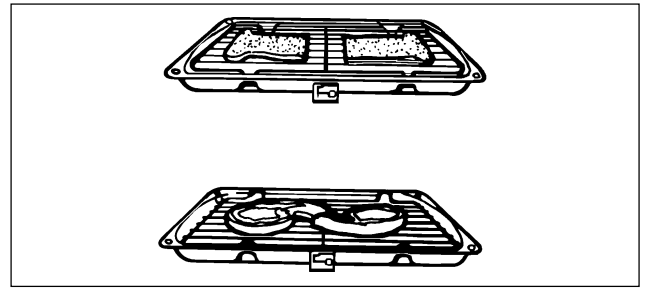

- Food should be thoroughly dried before grilling to minimise splashing. Brush lean meats and fish lightly with a little oil or melted butter to keep them moist during cooking.

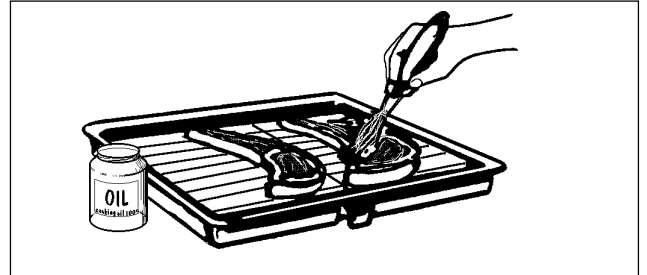

- Accompaniments such as tomatoes and mushrooms may be placed underneath the grid when grilling meats.

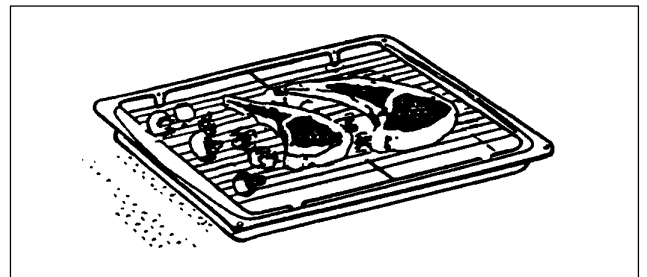

- The food should be turned over during cooking as required.

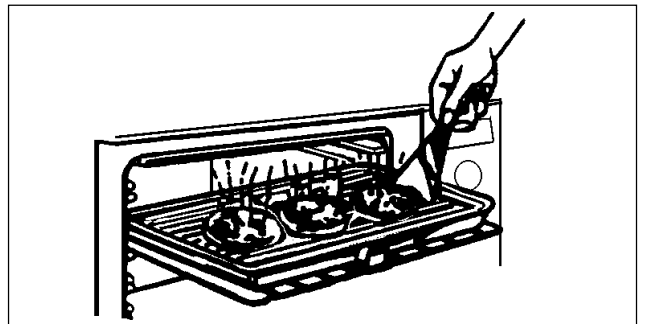

- The grill door must be left open when grilling. For convenience the grill door can be left ajar.

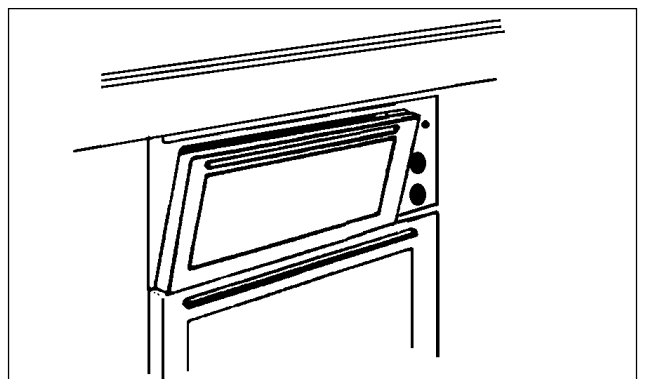

- Preheat the grill on full setting for a few minutes before searing steaks or toasting. Adjust the heat setting and the shelf position as necessary during cooking.

GRILLING CHART

The chart below gives recommended cooking times and shelf positions. Remember that these are a guide and should be adjusted to suit personal taste.

Note

Shelf positions are counted from the bottom upwards.

FOOD	Grill Time (Min)	Shelf	Grid Position
Bacon Rashers	3 - 5 each side	5	High
Beefburgers	6 - 10 each side	5	Low
Chicken Joints	15 - 20 each side	3	High
Chops - Lamb	7 - 10 each side	5	Low
- Pork	10 - 15 each side	5	Low
Fish - Whole Trout / Herring	8 - 12 each side	5	Low
Fillets - Plaice / Cod	4 - 6 each side	5	Low
Kebabs	10 - 15 each side	5	Low
Kidneys - Lamb	4 - 6 each side	5	Low
Pig	8 - 10 each side	5	Low
Liver - Lamb / Pig	5 - 10 each side	5	Low
Sausages	10 - 15 turn as required	5	Low
Steaks - Rare	3 - 6 each side	5	Low
Medium	6 - 8 each side	5	Low
Well Done	7 - 10 each side	5	Low
Browning e.g. au gratin, lasagne, shepherd's pie	3 - 5 mins	3	-

THE FAN ASSISTED CONVENIENCE OVEN

USES OF THE FAN ASSISTED OVEN

The Convenience oven is the smaller of the two ovens. It is convenient for mid-week meals where smaller quantities or convenience foods are being cooked. It is important to refer to the Convenience oven cooking chart as a guide to shelf positions and temperatures as these may differ from previous cookers you may have used.

HOW TO USE THE FAN ASSISTED OVEN

1. Turn the Convenience oven temperature control to the required setting.
2. Push in the Fan Selector button.

THINGS TO NOTE

- The Convenience oven indicator neon will glow until the oven has reached the desired temperature and then go out. It will cycle on and off periodically during cooking showing that the temperature is being maintained.
- The Fan Selector neon will glow throughout cooking.
- The cooling fan for the controls will operate after a time. See page 7 for more information on the operation of the cooling fan.



Do not place dishes, tins and trays directly on the oven base as it becomes very hot and damage will occur.

TO FIT THE OVEN SHELVES

There are 5 shelf positions in the Convenience oven. Shelf positions are counted from the bottom upwards.

The shelves should be fitted with the straight rods uppermost on the frame and the forms towards the back of the oven.

If not fitted correctly the anti-tilt and safety stop mechanism will be affected.

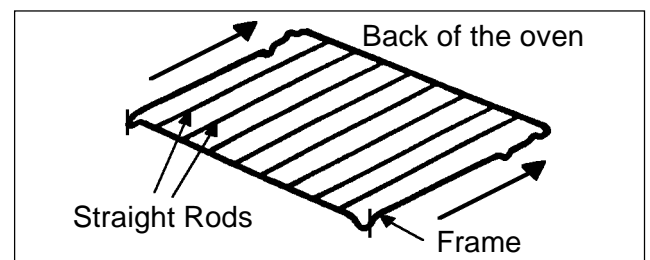
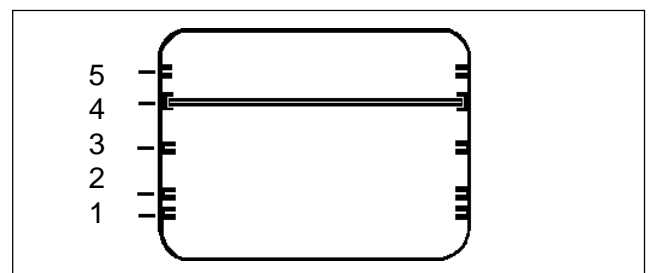
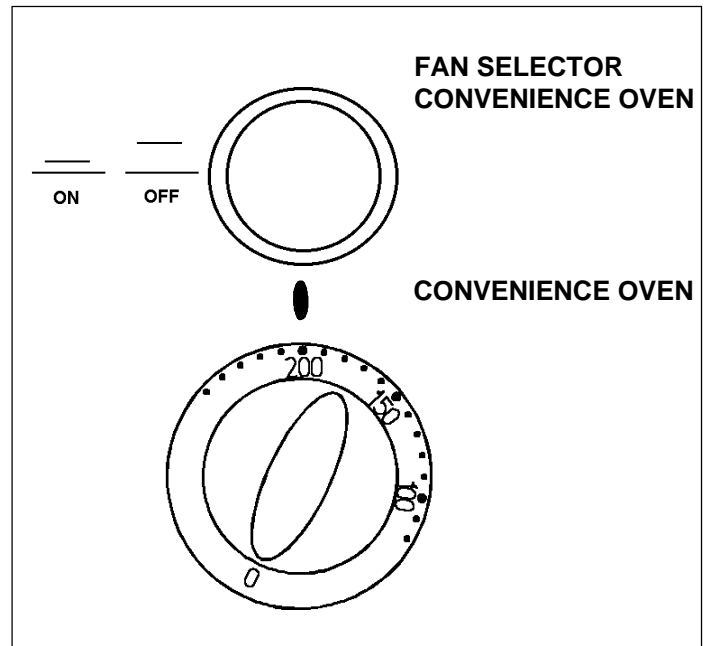

i HINTS AND TIPS

- Use the Convenience oven when you want to warm plates. Use a setting of 80°C - 100°C on the oven temperature control.
- You can use both shelves when using the fan assisted oven.
- There should always be at least 2.5cm (1") between the top of the food and the grill element. This gives best cooking results and allows room for rise in yeast mixtures, Yorkshire puddings etc. When cooking cakes, pastry, scones bread etc., place the tins or baking trays centrally on the shelf.
- Ensure that food is placed centrally on the shelf and there is sufficient room around the baking tray or dish to allow for maximum circulation.
- Where a degree of evenness in baking is required, it may be necessary to interchange food during cooking.
- Where a larger quantity of food is to be cooked we recommend you use the main fan oven.
- Place dishes on a suitably sized baking tray on the shelf to prevent spillage onto the oven base and to help reduce cleaning.
- The material and finish of the baking tray and dishes will affect the degree of base browning of the food. Enamelware, dark, heavy or non-stick utensils increase base browning. Shiny aluminium or polished steel trays reflect the heat away and give less base browning.
- For economy leave the door open for the shortest possible time, particularly when placing food into a pre-heated oven.
- Do not use the grill pan or meat tin as a baking tray as this will increase base browning of the food.
- Because of the smaller cooking space and lower temperatures, shorter cooking times are sometimes required. Be guided by the recommendations in the cooking chart.
- When roasting we recommend that you use the trivet in the meat tin. Fat and meat juices will drain into the meat tin below and can be used to make gravy. The trivet also prevents splashes of fat from soiling the oven interior.

Note. The meat tin should not be placed on a heated hotplate as this may cause the enamel to crack.

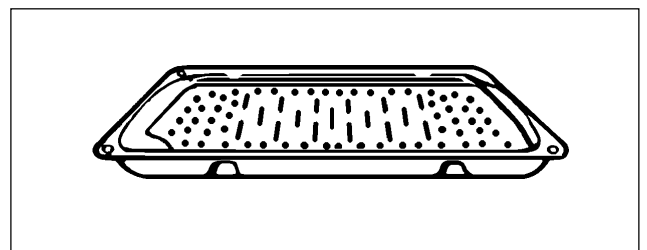
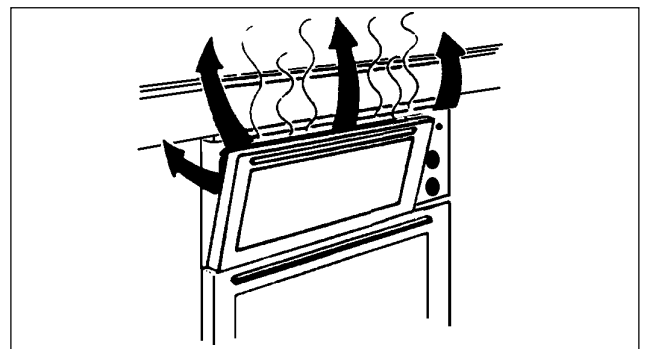
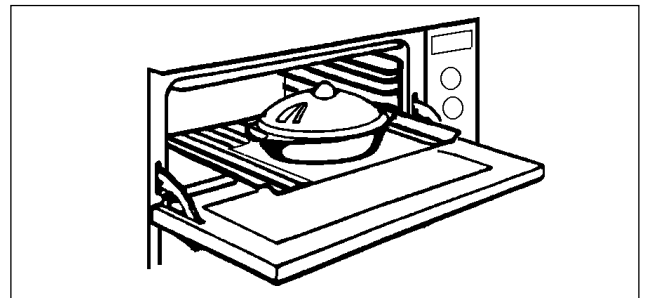
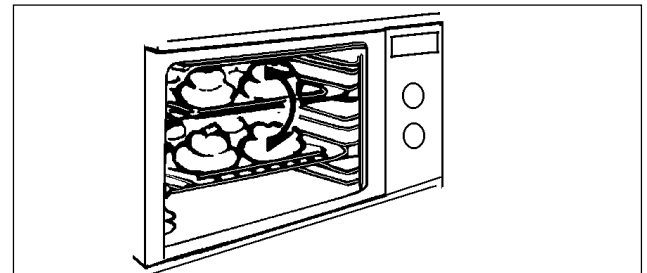
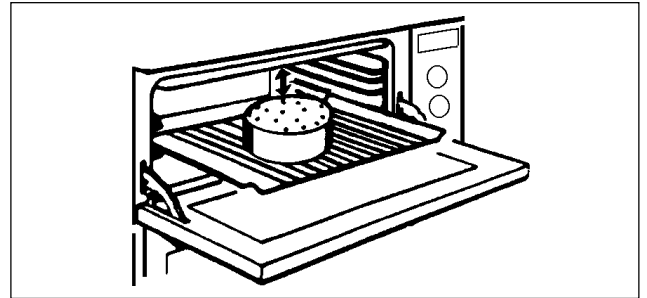

THE CONVENTIONAL CONVENIENCE OVEN

USES OF THE CONVENTIONAL OVEN

This form of cooking gives you the opportunity to cook without the fan in operation. It is particularly suitable for some cook chilled convenience foods and dishes which require extra base browning such as pizzas, quiches and flans. Gratin's, lasagne and hotpots which require extra top browning also cook well in the conventional oven. You can only cook on one shelf when using the conventional oven.

HOW TO USE THE CONVENTIONAL OVEN

1. Push out the Fan Selector button.
2. Turn the Convenience oven temperature control to the required setting.

THINGS TO NOTE

- The Convenience oven indicator neon will glow until the oven has reached the desired temperature and then go out. It will then cycle on and off showing that the oven temperature is being maintained.
- The cooling fan for the controls will operate after a short time. It may run on after the cooker has cooled. See page 7 for more details on the operation of the cooling fan.



Do not place dishes, tins or baking trays directly on the oven base as it becomes very hot and damage will occur.

TO FIT THE OVEN SHELF

There are 5 shelf positions in the Convenience oven. Shelf positions are counted from the bottom upwards.

The shelf should be fitted with the straight rods uppermost on the frame and the forms towards the back of the oven.

If not fitted correctly the anti-tilt and safety stop mechanism will be affected.

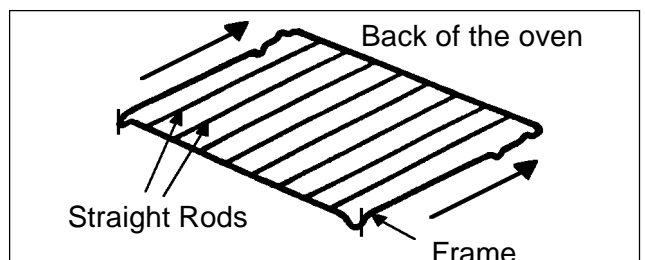
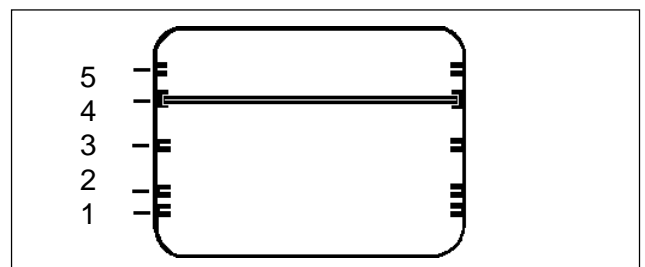
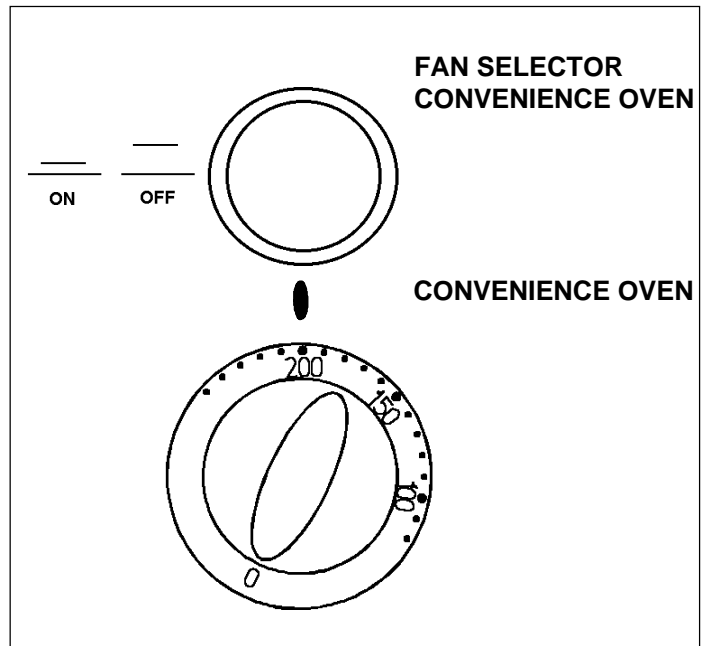

i HINTS AND TIPS

- The middle shelf allows for the best heat distribution. To increase base browning simply lower the shelf position. To increase top browning, raise the shelf position.
- The material and finish of the baking trays and dishes used will affect base browning. Enamelware, dark heavy or non-stick utensils increase base browning, while oven glassware, shiny aluminium or polished steel trays reflect the heat away and give less base browning.
- Always place dishes centrally on the shelf to ensure even browning.
- Stand dishes on suitably sized baking trays to prevent spillage onto the base of the oven and make cleaning easier.
- For faster preheating use the fan assisted oven to preheat the oven until the oven indicator neon goes out, then press the fan selector button out to the conventional oven setting.
- Single level cooking gives best results. If you require more than one level of cooking use the fan assisted function or main fan oven.
- Because of the smaller cooking space and lower temperature, shorter cooking times are sometimes required. Be guided by the recommendations in the cooking chart.
- For economy leave the oven door open for the shortest possible time particularly when placing food in a preheated oven.
- Where a larger quantity of food is to be cooked we recommend you use the fan assisted or main fan oven.

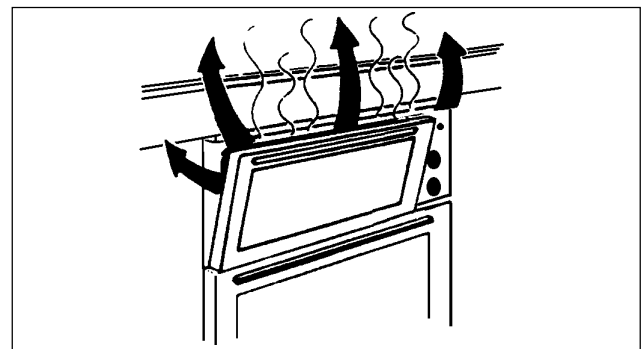
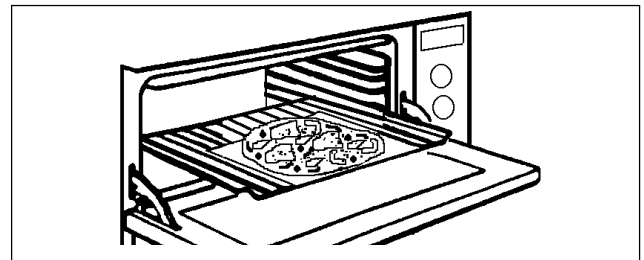
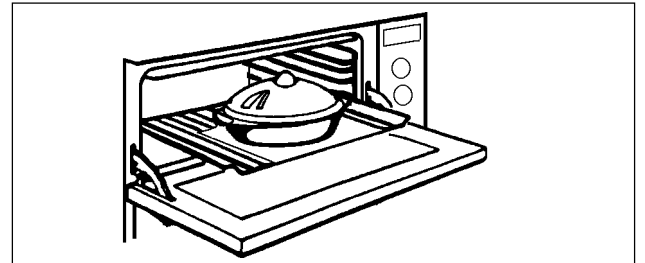
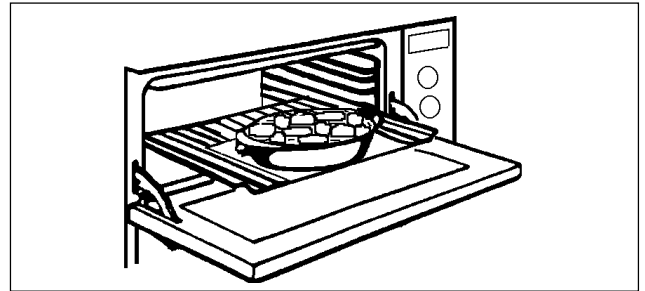
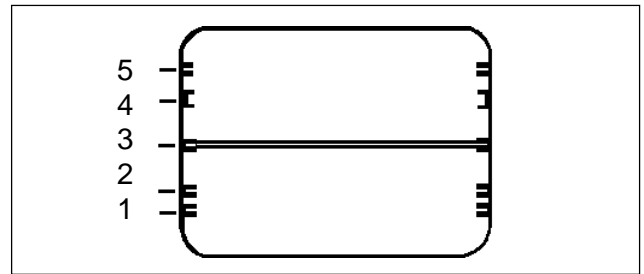

CONVENIENCE OVEN COOKING CHART

The oven temperatures are intended as a guide only. It may be necessary to increase or decrease the temperatures by a further 10°C to suit individual preferences and requirements.

Note: Shelf positions are counted from the bottom of the oven.

FOOD	CONVENTIONAL OVEN		FAN ASSISTED OVEN	
	SHELF POSITION	TEMP (°C)	SHELF POSITION	TEMP (°C)
Biscuits	3	170 -190	2 & 4	160 - 170
Bread	3	210 - 220	2	200 - 210
Bread Rolls / Buns	3	210 -220	2 & 4	160 - 170
Cakes:				
Small & Queen	3	180 - 190	2 & 5	160 - 170
Sponges	2	180 - 190	2 & 5	160 - 170
Victoria Sandwich	2	180 - 190	2 & 4	160 - 170
Madeira	3	160 - 170	2	140 - 150
Rich Fruit	3	140 - 150	2	130 - 140
Gingerbread	3	150 - 160	2 & 4	140 -150
Meringues	2	80 - 100	2 & 4	90 - 100
Flapjack	3	180 - 190	3	170 - 180
Shortbread	3	140 - 150	3	130 - 140
Baked Custard	3	160 - 170	3	150 - 160
Casseroles :				
Beef / Lamb	2	150 - 160	4	140 - 150
Chicken	2	140 - 160	4	140 -160
Convenience Foods	3	Refer to Packaging	2 & 4	Refer to Packaging
Fish	3	170 - 190	3	150 - 170
Fish Pie - potato topped	3	200 - 210	7	180 -190
Fruit Pies, Crumbles	3	190 - 200	3	190 - 200
Milk Puddings	3	140 - 150	3	130 - 140
Pasta / Lasagne etc.	3	190 - 200	3	170 - 180
Pastry : Choux -	3	190 - 200	3	190 - 200
Eclairs/profiteroles	3	190 - 200	3	190 - 200
Flaky / Puff pies	3	200 - 210	3	190 - 200
Shortcrust -	3	190 - 200	2 & 4	170 - 180
Mince pies	3	190 - 200	2 & 4	170 - 180
Meat pies	3	210 - 220	2 & 4	170 - 180
Quiche, Tarts, Flans	3	180 - 190	3	180 - 190
Roast Meat / Poultry	1	160 - 180	2	160 - 180
Scones	3	220 -230	2 & 4	210 - 220
Shepherds Pie	3	200 - 210	3	200 - 210
Soufflés	3	190 - 200	3	160 - 170
Vegetables : Baked Jacket Potatoes	3	190 - 200	3	200 - 210
Roast Potatoes	3	200 - 210	4	170 - 180
Yorkshire Puddings - large	3	210 - 220	4	210 - 220
- individual	3	210 - 220	4	210 - 220

THERMAL GRILLING IN THE CONVENIENCE OVEN

USES OF THERMAL GRILLING

Thermal grilling in the Convenience oven offers an alternative method of cooking food items normally associated with conventional grilling.

The grill element and the oven fan operate together, circulating hot air around the food. The need to check and turn food is reduced. Thermal grilling helps to minimise cooking smells in the kitchen and allows you to grill with the oven door closed. With the exception of toast and rare steaks you can thermal grill all the foods you would normally cook under a conventional grill.

Dishes prepared in advance such as shepherd's pie, lasagne and au gratin's can be heated through and browned on the top using the thermal grilling function.

COOKING TIMES

Cooking is more gentle, therefore food generally takes a little longer to cook when thermal grilling compared with conventional grilling. One of the advantages is that larger quantities can be cooked at the same time.

A general guide to cooking times is given on page 26 but these times may vary slightly depending on the thickness and quantity of food being cooked.

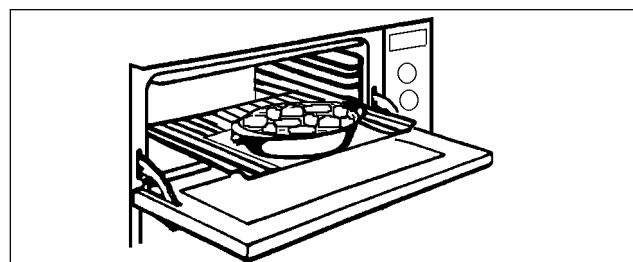
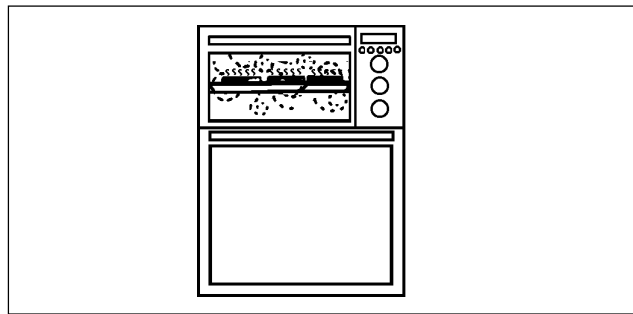

HOW TO THERMAL GRILL



Always thermal grill with the oven door closed and with the grill pan handle removed.

1. Press in the Fan Selector button.
2. Turn the Dual Grill control to the required setting.
3. Locate the grill pan on shelf 3 or 5.
4. Remove the handle from the grill pan and close the oven door.



If you use the grill pan in position 3, the shelf must be withdrawn before the pan can be located or removed. Ensure the grill pan is properly located.

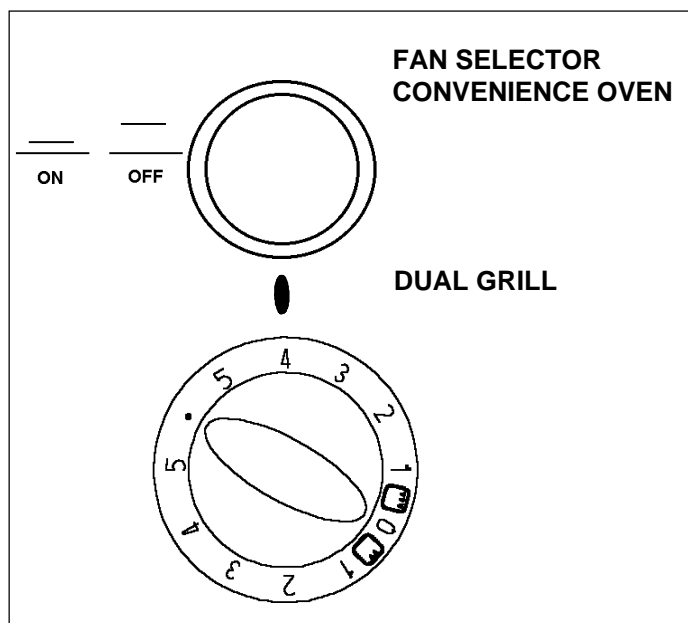

THINGS TO NOTE

- Setting 4 is suitable for most foods.
- The Grill indicator neon will glow throughout cooking.
- The Selector indicator neon will glow throughout cooking.
- The oven fan will operate continually during thermal grilling.
- The cooling fan for the controls will come on when the grill control is turned. It may run on after the controls are switched off until the cooker has cooled. See page 7 for more details on the operation of the cooling fan.

i HINTS AND TIPS

- Prepare foods in the same way as for conventional grilling. Brush lean meats and fish lightly with a little oil or butter to keep them moist during cooking.
- Most food should be placed on the grill pan grid in the 'high' position in the grill pan to allow maximum circulation of air around the food. Foods such as fish, liver and kidneys may be placed directly onto the trivet in the grill pan if preferred.
- The use of the trivet beneath the grid when grilling fatty foods will help minimise fat splashing.
- Accompaniments such as tomatoes and mushrooms may be placed below the grid when grilling meats, or in a separate dish on a lower shelf.

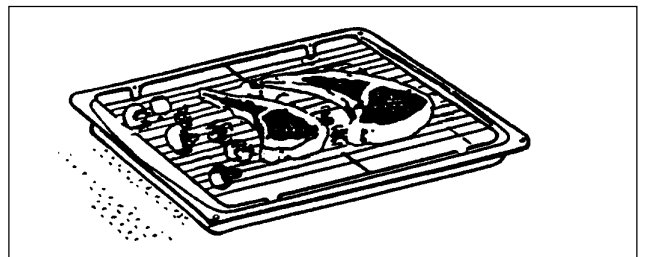
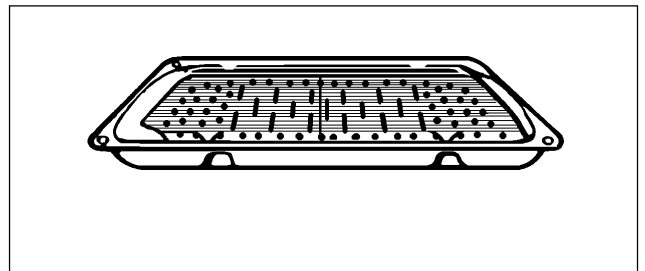
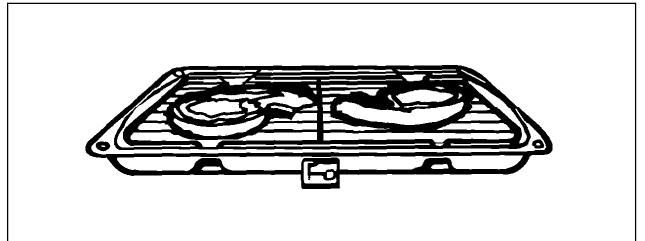
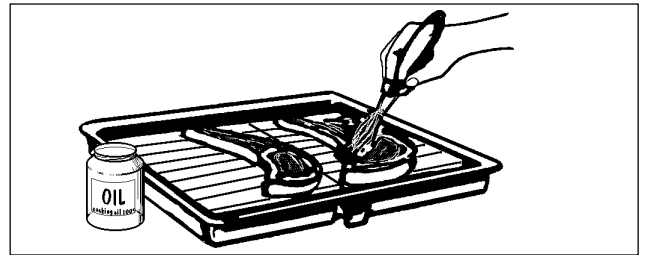

- Turn food over during cooking as necessary.

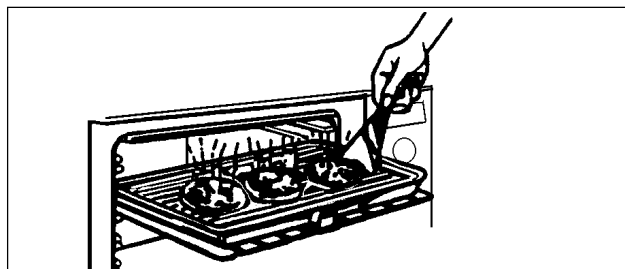

- Ensure that ready prepared or cooked chilled dishes e.g. shepherds pie, moussaka, lasagne, etc., are piping hot throughout before serving.

- Grilling at setting 4 and shelf position 3 is suitable for most foods. Be prepared to make suitable adjustments during cooking to suit individual requirements. It may be necessary to turn down as required. If thermal grilling on more than one level, it may be necessary to interchange the food on the shelves during cooking.

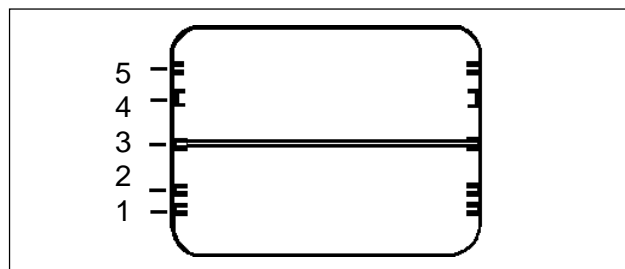

- With the exception of toast and rare steak you can thermal grill all foods normally grilled by conventional methods.

THERMAL GRILLING CHART

FOOD	SHELF	GRILL SETTING	TIME (mins in total)
Bacon Rashers	3	4	8 - 12 mins
Beefburgers	3	4	10 - 15 mins
Chicken Joints	3	3	30 - 40 mins
Chops - Lamb / Pork	3	4	20 - 25 mins
Fish - Whole Trout / Mackerel	3	4	10 - 20 mins
Filletts - Plaice / Cod	3	4	10 - 15 mins
Kebabs	3	4	20 - 30 mins
Kidneys - Lamb / Pig	3	4	10 - 15 mins
Liver - Lamb / Pig	3	4	20 - 30 mins
Sausages	3	4	10 - 15 mins
Steaks - Medium	3	4	8 - 10 mins
- Well Done	3	4	10 - 12 mins
Heating through and browning eg. au gratin, lasagne, Shepherds pie	3	4	depends on dish

TO COOL AND DEFROST IN THE CONVENIENCE OVEN

USES OF COOLING AND DEFROST

This function enables you to cool down hot food and defrost most foods without heat faster than some conventional methods as the oven fan circulates air around the food. It is particularly suitable for defrosting delicate frozen foods which are to be served cold e.g. cream filled gateaux, cakes covered with icings or frostings, cheesecakes, biscuits, scones etc.

In addition, hot food such as casseroles can be cooled down more quickly than by conventional means.

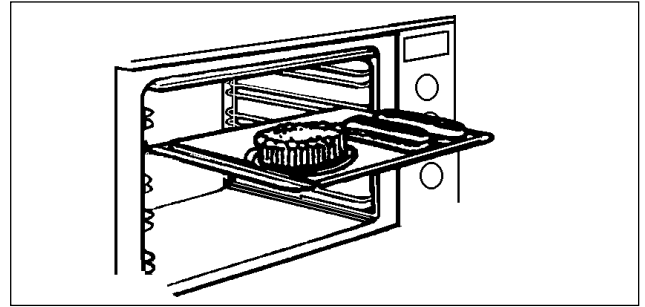

HOW TO COOL / DEFROST

1. Press in the Fan Selector button.
2. The Convenience oven temperature control should be in the Off '0' position.

THINGS TO NOTE

- The oven fan and internal oven light will operate.
- The fan selector indicator neon will illuminate.

HINTS AND TIPS

- Place the frozen food in a single layer where possible and turn it over half way through the defrosting process.
- The actual speed of defrosting is influenced by room temperature. On warm days defrosting will be faster than on cooler days.
- It is preferable to thaw fish, meat and poultry slowly in the fridge. However, this process can be accelerated by using the defrost function. Small or thin fish fillets, frozen peeled prawns, cubed or minced meat, liver, thin chops, steaks etc., can be thawed in 1 - 2 hours.
- A 1kg/2¼lb oven ready chicken will be thawed in approximately 5 hours. Remove the giblets as soon as possible during the thawing process.

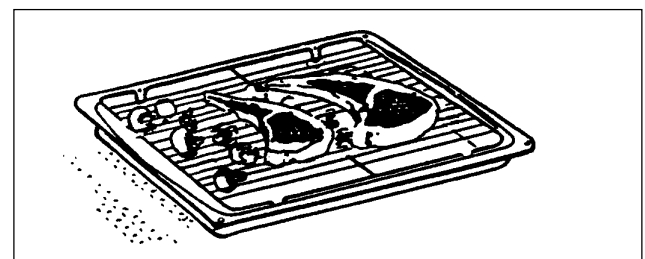
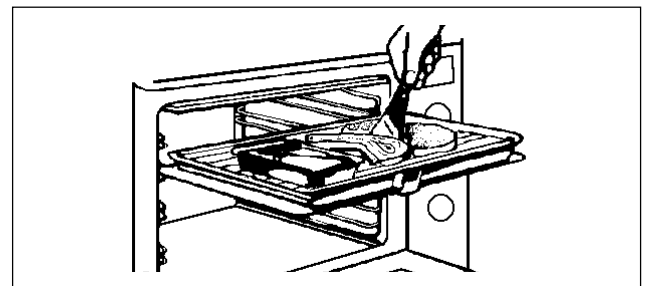
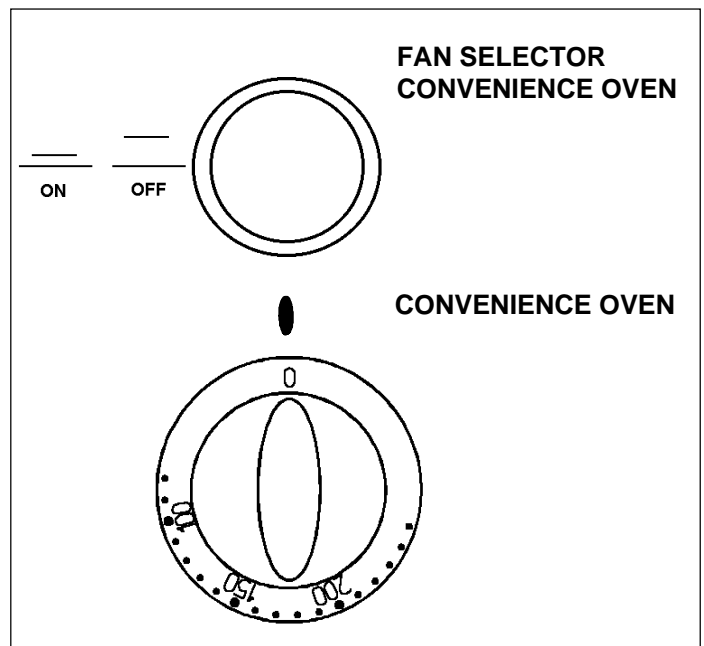

- Joints of meat up to 2kg/4½lb in weight can be thawed using the defrost function.
- All joints of meat and poultry must be thawed thoroughly before cooking.
- DO NOT leave food at room temperature once it is defrosted. Cook raw food immediately or store cooked food in the fridge.
- Care must always be taken when handling foods in the home. Always follow the basic rules of food hygiene to prevent bacterial growth and cross contamination when defrosting, preparing, cooking cooling and freezing foods. This is particularly important if the main fan oven is in use or is warm, as the temperature in the Convenience oven will be higher than room temperature.

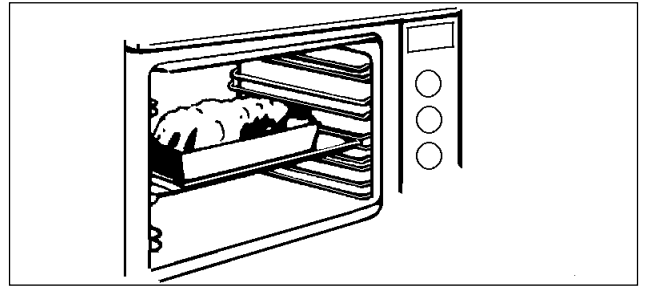

THE MAIN FAN OVEN

USES OF THE FAN OVEN

The main fan oven is particularly suitable for cooking larger quantities of food. The advantages of fan oven cooking are:

PREHEATING

The fan oven quickly reaches its temperature so it not usually necessary to preheat the oven. Without preheating however you may need to add an extra 5 - 10 minutes on the recommended cooking times. For recipes needing high temperatures e.g. bread, pastries, scones, soufflés etc., best results are achieved if the oven is preheated first.

COOKING TEMPERATURES

Fan oven cooking generally requires lower temperatures than conventional cooking. Follow the temperatures recommended in the chart on page 31 until you are familiar with the lower temperatures associated with Fan oven cooking. As a guide reduce temperatures by 20°C - 25°C for your own recipes.

BATCH BAKING

The fan oven cooks evenly on all shelf levels, especially useful when batch baking.

HOW TO USE THE FAN OVEN

1. Turn the Fan oven temperature control to the required setting.

THINGS TO NOTE

- The oven light will come on when the control is turned.
- The oven fan will operate continually during cooking.
- The cooling fan for the controls will operate after a time. See page 7 for further details on the operation of the cooling fan.
- The fan oven indicator neon will glow until the oven has reached the desired temperature. It will cycle on and off periodically during cooking showing that the temperature is being maintained.
- If an automatic programme has been set, the oven fan and oven light do not come on until the cook time begins.

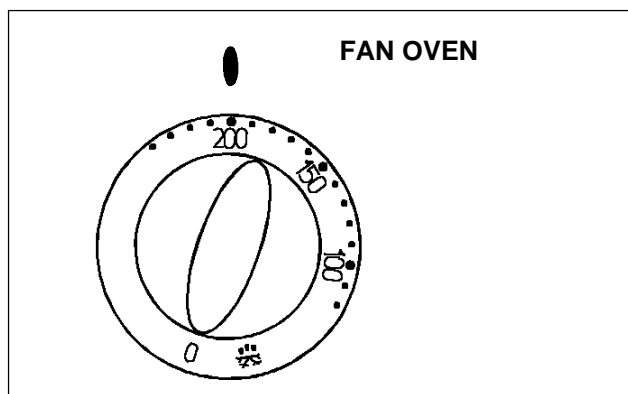
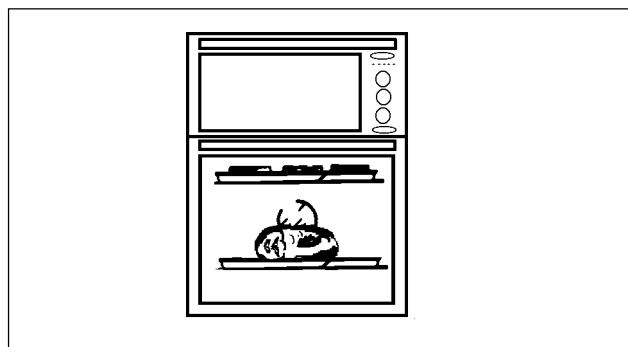

TO FIT THE FAN OVEN SHELVES

The shelves should be fitted with the straight rods uppermost on the frame and the forms towards the back of the oven. If not fitted correctly the anti-tilt and safety stop mechanism will be affected.

HINTS AND TIPS

- Arrange the shelves in the required positions before switching the oven on. Shelves are numbered from the bottom upwards.
- The material and finish of the baking trays and dishes used will affect base browning. Enamelware, dark heavy or non-stick utensils increase base browning, while oven glassware, shiny aluminium or polished steel trays reflect the heat away and give less base browning.
- When cooking more than one dish in the fan oven, place dishes centrally on different shelves rather than cluster several dishes on one shelf, this will allow the heat to circulate freely for the best cooking results.
- It is recommended that when baking larger quantities, the shelf positions should be evenly spaced to suit the load being cooked. A slight increase in cooking time may be necessary.
- The use of excessively high temperatures can cause uneven browning. It may be necessary to reduce temperatures slightly. Refer to the recommendations given in the oven cooking chart, on page 31.

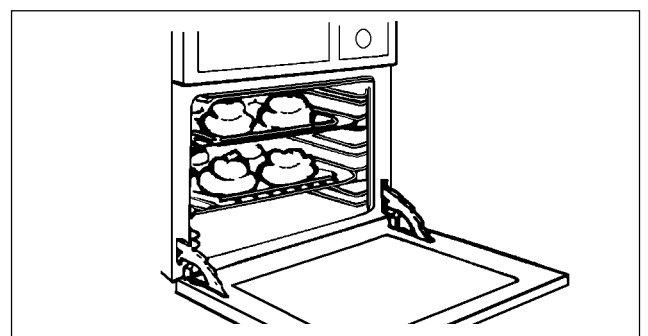
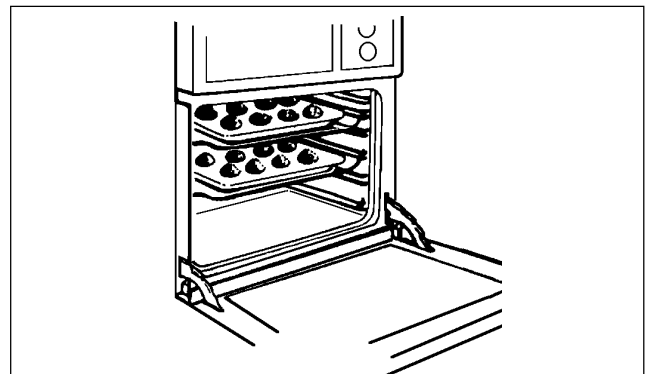
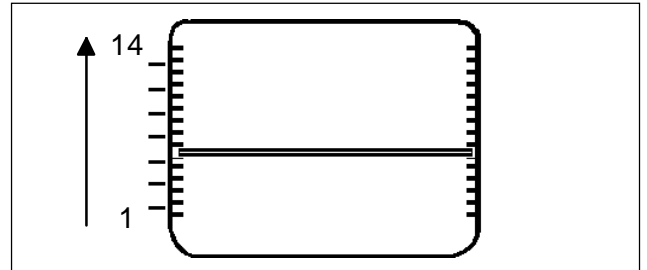
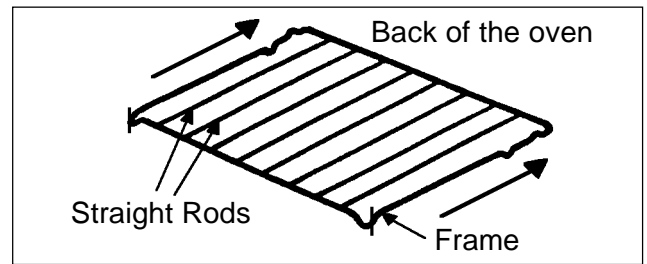

FAN OVEN COOKING CHART

The oven temperatures are intended as a guide only. It may be necessary to increase or decrease the temperatures by a further 10°C to suit individual preferences and requirements.

Note: Shelf positions are counted from the bottom of the oven.

FOOD	SHELF POSITION	TEMP (°C)
Biscuits	2 & 12	160 -190
Bread	1 & 9	210 -220
Bread Rolls / Buns	2 & 12	210 -220
Cakes:		
Small & Queen	2 & 12	160 -170
Sponges	4 & 11	160 -170
Victoria Sandwich	4 & 11	160 -170
Madeira	7	140 - 150
Rich Fruit	7	140 -150
Christmas	7	130 - 140
Gingerbread	4 & 11	140 -150
Meringues	4 & 11	90 - 100
Flapjack	4 & 11	170 - 180
Shortbread	7	140 - 150
Baked Custard	7	140 - 150
Casseroles :		
Beef / Lamb	7	140 - 150
Chicken	7	160 -180
Convenience Foods	Any	According to Manufacturers Instructions
Fish	7	150 - 170
Fish Pie - potato topped	7	190 - 200
Fruit Pies, Crumbles	4 & 11	180 -190
Milk Puddings	7	130 - 140
Pasta / Lasagne etc.	7	180 - 190
Pastry : Choux -		
Eclairs/profiteroles	4 & 11	160 - 170
Flaky / Puff pies	7	210 - 220
Shortcrust -		
Mince pies	4 & 11	170 - 180
Meat pies	4 & 11	210 - 220
Quiche, Tarts, Flans	7	180 - 190
Roast Meat / Poultry	4	160 - 180
Scones	2 & 12	200 -210
Shepherds Pie	7	190 - 200
Soufflés	7	170 - 180
Vegetables :		
Baked Jacket Potatoes	7	190 - 200
Roast Potatoes	7	200 - 210
Yorkshire Puddings - large	10	210 -220
- individual	10	210 -220

ROASTING CHART

ROASTING CHART		
INTERNAL TEMPERATURES Rare: 50 - 60°C; Medium: 60 - 70°C; Well Done: 70 - 80°C		
MEAT	FAN OVEN	COOKING TIME
Beef	160 - 180°C	20 - 35 min per ½kg/1lb and 20 - 35 min over
Beef, boned	160 - 180°C	20 - 35 min per ½kg/1lb and 25 - 35 min over
Mutton and Lamb	160 - 180°C	25 - 35 min per ½kg/1lb and 25 - 35 min over
Pork and Veal	160 - 180°C	30 - 40 min per ½kg/1lb and 30 - 40 min over
Ham	160 - 180°C	30 - 40 min per ½kg/1lb and 30 - 40 min over
Chicken	160 - 180°C	15 - 20 min per ½kg/1lb and 20 min over
Turkey and Goose	160 - 180°C	15 - 20 min per ½kg/1lb up to 3½kg/7lb then 10 min per ½kg/1lb
Duck	160 - 180°C	25 - 35 min per ½kg/1lb and 25 - 30 min over
Pheasant	160 - 180°C	35 - 40 min per ½kg/1lb and 35 - 40 min over
Rabbit	160 - 180°C	20 min per ½kg/1lb and 20 min over
Potatoes with meat	160 - 180°C	according to size
Potatoes without meat	180 - 190°C	according to size

The roasting temperatures and times given in the chart should be adequate for most joints, but slight adjustments may be required to allow for personal requirements and the shape and texture of the meat. However, lower temperatures and longer cooking times are recommended for less tender cuts or larger joints.

Wrap joints in foil if preferred, for extra browning uncover for the last 30 - 60 min. cooking time.

DEFROSTING IN THE MAIN FAN OVEN

USES OF DEFROST FEATURE

This main oven function enables you to defrost most foods without heat faster than some conventional methods as the oven fan circulates air around the food. It is particularly suitable for delicate frozen foods which are to be served cold e.g. cream filled gateaux, cakes covered with icings or frostings, cheesecakes, biscuits, scones etc.

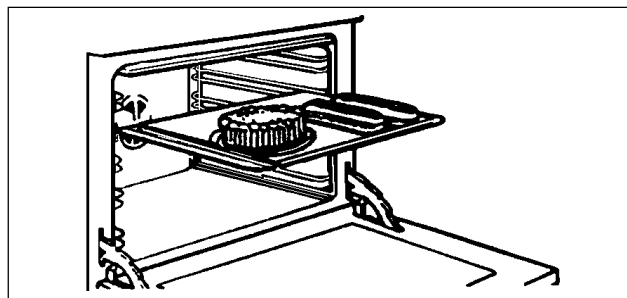

HOW TO USE DEFROST

1. Turn the Fan oven temperature control to Defrost setting. 

2. This function **DOES NOT** require a temperature setting on the fan oven temperature control.

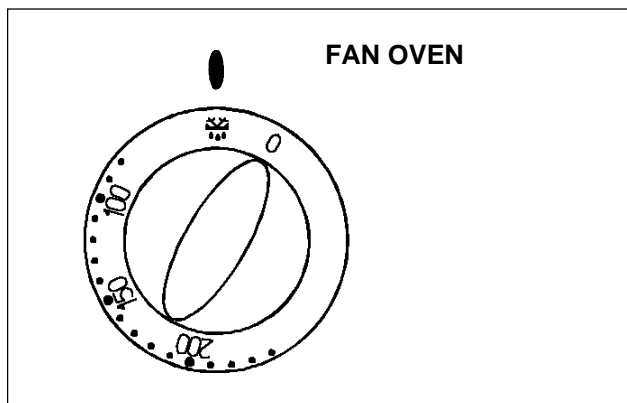

THINGS TO NOTE

- The oven fan and internal oven light will operate.

HINTS AND TIPS

- Place the frozen food in a single layer where possible and turn it over half way through the defrosting process.
- The actual speed of defrosting is influenced by room temperature. On warm days defrosting will be faster than on cooler days.
- It is preferable to thaw fish, meat and poultry slowly in the fridge. However, this process can be accelerated by using the defrost function. Small or thin fish fillets, frozen peeled prawns, cubed or minced meat, liver, thin chops, steaks etc., can be thawed in 1 - 2 hours.
- A 1kg/2¼lb oven ready chicken will be thawed in approximately 5 hours. Remove the giblets as soon as possible during the thawing process.

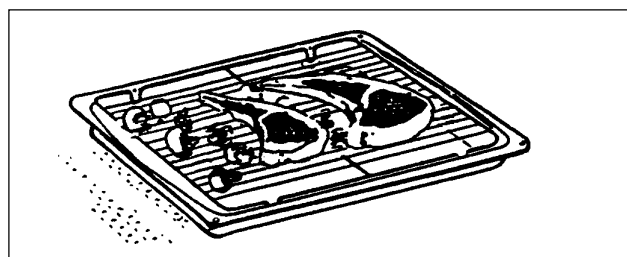
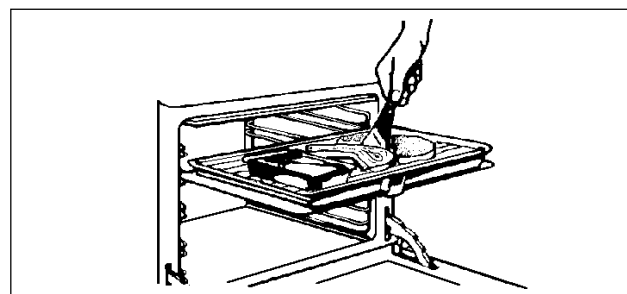

- Joints of meat up to 2kg/4½lb in weight can be thawed using the defrost function.
- All joints of meat and poultry must be thawed thoroughly before cooking.
- Always cook thoroughly immediately after thawing.
- DO NOT leave food at room temperature once it is defrosted. Cook raw food immediately or store cooked food in the fridge.
- Care must always be taken when handling foods in the home. Always follow the basic rules of food hygiene to prevent bacterial growth and cross contamination when defrosting, preparing, cooking cooling and freezing foods.

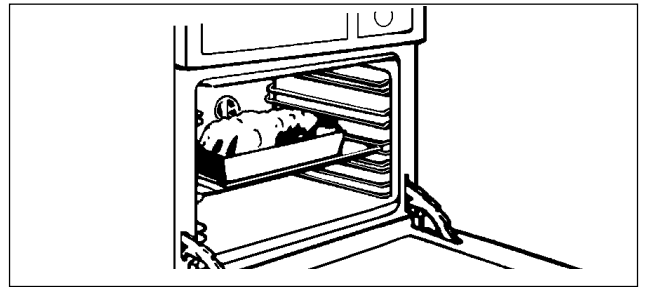

CARE AND CLEANING



Before cleaning the cooker always allow the cooling fan for the controls to cool the cooker down before switching off the electricity supply.

CLEANING MATERIALS

Before using any cleaning materials on your cooker, check that they are suitable and that their use is recommended by the manufacturer.

Cleaners that contain bleach should NOT be used as they may dull the surface finishes. Harsh abrasives should also be avoided.

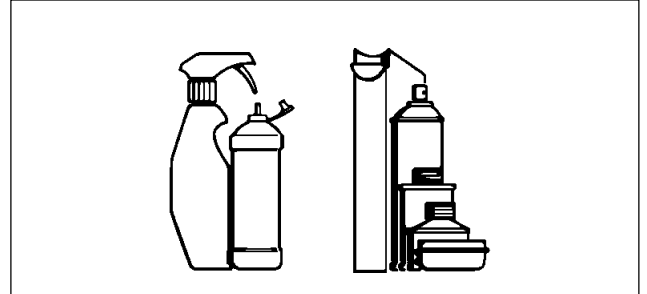

CLEANING THE OUTSIDE OF THE COOKER

DO NOT use abrasive cleaning materials or scourers on the outside of the cooker as some of the finishes are painted and damage may occur. Regularly wipe over the control panel and oven doors using a soft cloth well wrung out in warm water to which a little liquid detergent has been added.

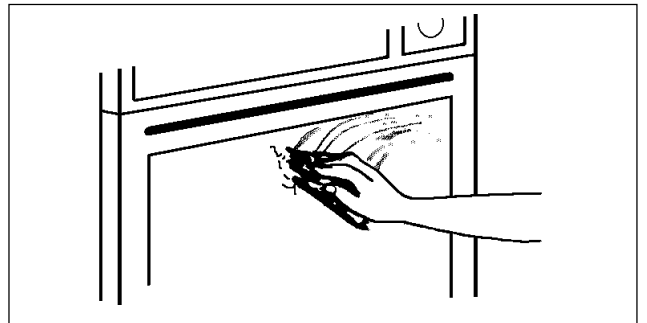

Do not attempt to remove any of the control knobs from the panel as this may cause damage and is a safety hazard.

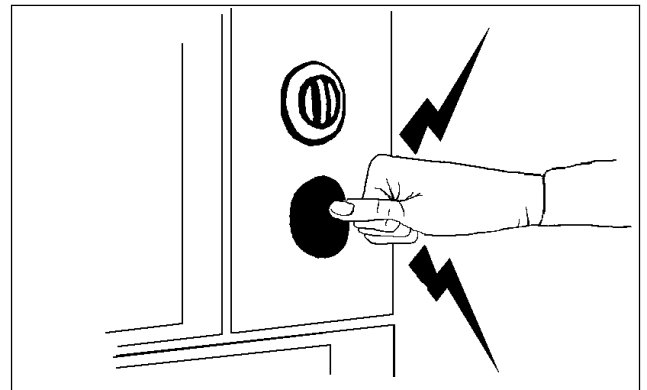

CLEANING THE OUTER AND INNER DOOR GLASS PANELS



To prevent damaging or weakening the door glass panel avoid the use of the following:

- Household detergents and bleaches
- Impregnated pads unsuitable for non-stick saucepans
- Brillo/Ajax pads or steel wool pads
- Chemical oven pads or aerosols
- Rust removers
- Bath/Sink stain removers

The outer oven door glass panels are removable for cleaning.

TO REMOVE THE OUTER GLASS

1. Open the oven door slightly to gain access to the two cross head screws on the top of the oven door.
2. Loosen the two screws using a Pozidrive screwdriver.
3. Holding the door glass securely in place with one hand remove the screws and washers with the other hand.

The screws and washers retain the trim on the top of the grill door. Note the position of the trim on the door.

4. Holding the door and glass with one hand, pull towards you and slightly lift the door glass with the other hand to disengage the panel from the location point at the bottom of the door. Gently release the door to close it.
5. Clean the outer and inner glass using hot soapy water or Hobbrite. Should the inner face of the outer door glass be heavily soiled it is recommended that soapy water with a high concentration of soap is used. To prevent streaking a glass cleaning spray may be applied and the glass polished with a soft cloth. Ensure that all parts are well rinsed and thoroughly dry before attempting to replace the outer door glass.



If the door glass panel becomes chipped or has deep scratches the glass will be weakened and must be replaced to prevent the possibility of the panel shattering. Please contact your local Service Centre who will be pleased to advise further.

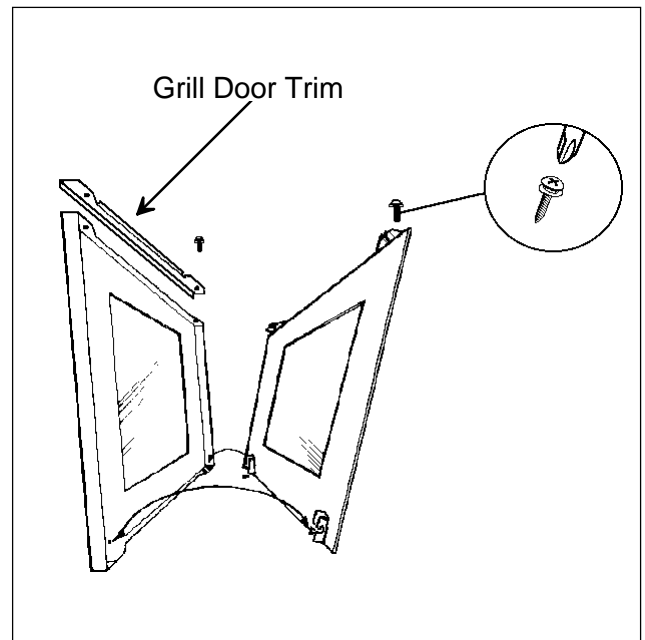

TO REPLACE THE OUTER DOOR GLASS

1. Holding the door glass panel with both hands, gently place the locators into the holes of the brackets at the bottom of the oven door.
2. Holding the door glass with your left hand, use your right hand to open the oven door. Bring the door gently towards the glass panel ensuring the screw location holes line up.
3. Place the trim in the correct position on the top of the grill door.
4. Hold the glass in place with one hand and insert the cross head screws with washers into the location holes with the other hand. Give the screws one turn to ensure the glass is secure.
5. Tighten the screws positively with a Pozidrive screwdriver before closing the oven door.

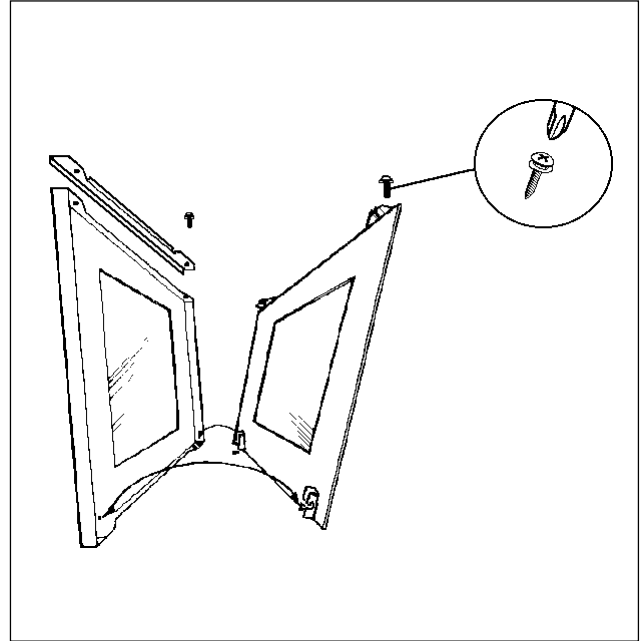

DO NOT attempt to use the oven without the glass being in place.

TO CLEAN THE INNER GLASS DOOR

The inner glass door is not removable. Clean using hot soapy water or Hobbrite and a soft cloth. **DO NOT** use abrasives as they may damage the glass or seal.

CLEANING INSIDE THE OVENS

The oven top, sides and back panels are coated with a Stayclean finish.

The Stayclean areas should not be cleaned manually. See Care of Stayclean Surfaces on page 38.

The base of the ovens can be cleaned using normal oven cleaners or aerosol oven cleaners with care. Ensure that the manufacturers instructions are followed and that all parts are well rinsed afterwards.

Do not use any cleaning agents or scrapers on the oven tops, sides, back panels and door seals.

Damage will occur if soap impregnated steel wool pads, aerosol cleaners or any abrasive cleaners are used.

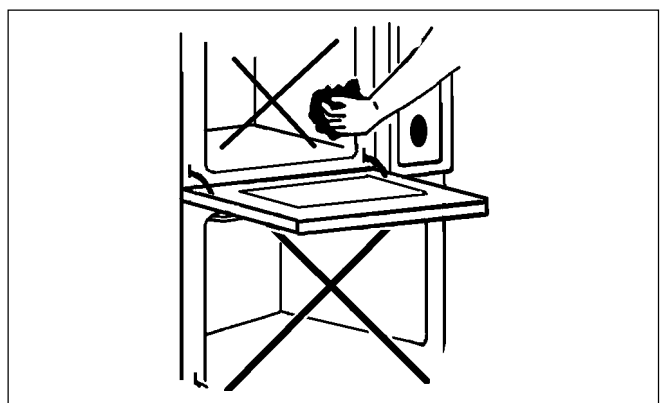

TO REMOVE THE WIREWORK RUNNERS

The wirework runners in both ovens can be removed for cleaning.

1. Remove all shelves and furniture from the oven.
2. Hold the wirework at the bottom and gently pull towards the centre of the oven.
3. Unhook the runner at the top and remove it from the cavity.
4. To replace, hook the wirework back into the oven sides.



Ensure that the wirework runners are firmly in place before refitting the oven shelves.

CLEANING THE SHELVES, WIREWORK RUNNERS AND OVEN FURNITURE

Soak the oven shelves, wirework runners and grilling grid in hot soapy water if heavily soiled, they will then clean more easily. If the shelves are heavily soiled a soap impregnated steel wool pad can be used.

The grill pan, meat tin and trivet can be cleaned using a soap impregnated steel wool pad.

All items of grill and oven furniture are dishwasher safe with the exception of the grill pan handle.

CARE OF STAYCLEAN SURFACES

The top, sides and back panels of both ovens are coated with a Stayclean finish. They should not be cleaned manually. Aerosol cleaners must not be used on Stayclean surfaces and must not come into contact with elements or the door seal, as this may cause damage.

During normal use the Stayclean coating will become splashed with fats and food residues. By running the oven without food, the Stayclean surfaces burn off any soilage. Regular use of the oven cleaning cycle will help to keep the panels in good condition.

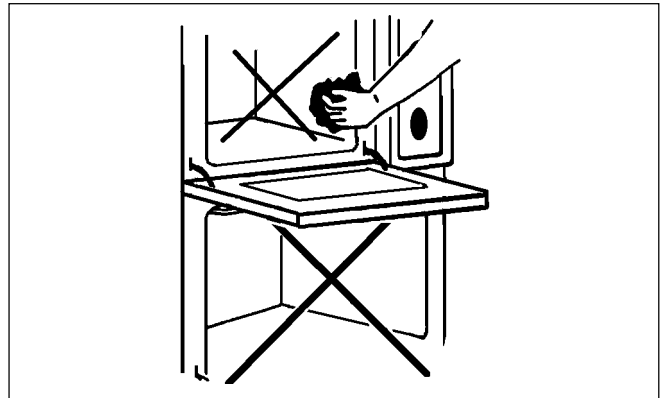
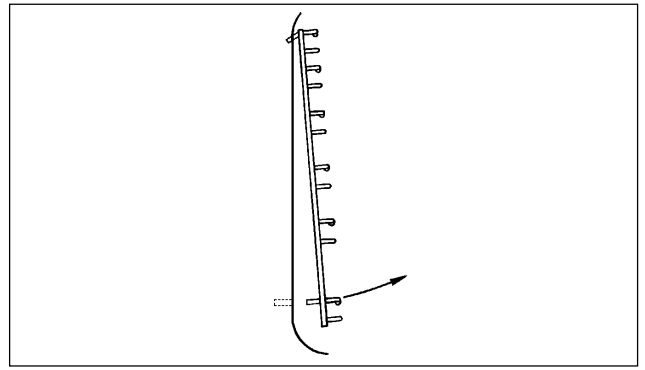

THE OVEN CLEANING CYCLE - BOTH OVENS

1. Remove oven shelves, wirework runners and bakeware from oven.
2. Turn the required oven temperature control to 220°C and allow the oven to run for an hour or so.
3. To clean the Convenience oven push in the Fan Selector button.

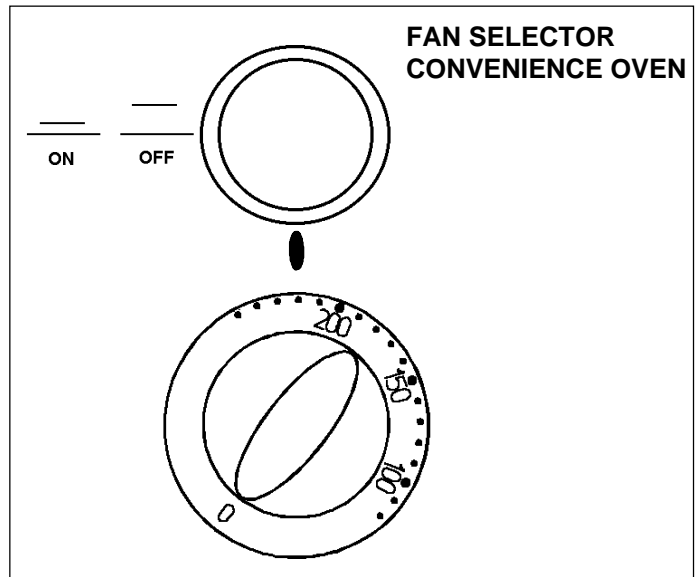
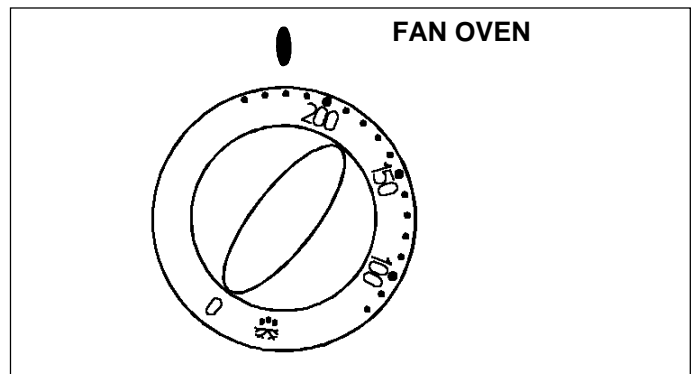

THINGS TO NOTE

- The oven indicator neon will glow until the oven has reached the desired temperature and then go out. It will then cycle on and off showing that the oven temperature is being maintained.
- The Selector indicator neon will glow throughout the oven cleaning cycle when the Convenience oven is in use.
- The cooling fan for the controls will operate after a short time. It may run on after the controls are switched off until the cooker has cooled. See page 7 for more details on the operation of the cooling fan.

i HINTS AND TIPS

- Slight discolouration and polishing of the Stayclean surfaces may occur in time, but this will not affect their self cleaning properties.
- A good time to use the oven cleaning cycle is after the weekly roast.
If you do a lot of roasting and very little baking you should follow the cleaning cycle every week. If you roast very little you will only need to follow the cleaning cycle every 2 - 3 weeks.
- Follow the recommendations below to keep soilage to a minimum.

COOKING TO REDUCE SOILAGE

- Cook at the recommended temperatures. Higher temperatures during roasting will increase soilage. Try cooking at lower temperatures for an increased length of time, you will save energy and often the joint is more tender.

- Use minimal, if any, extra oil or fat when roasting meat, potatoes only require brushing with fat before cooking. Extra fat in the oven during roasting will increase splashing and soilage.
- It is not necessary to add water to the meat tin when roasting. The water and the fat juices from the joint create excessive splattering during cooking, even at normal temperatures, as well as causing condensation.
- Covering joints during cooking will also prevent splashing onto the interior surfaces. Removing the covering for the last 20-30 minutes will allow extra browning if required. Some large joints and turkeys especially benefit by this method of cooking, allowing the joint to cook through before the outside is overbrowned.
- Do use the trivet in the roasting tin. During roasting the fat from the joint will be contained beneath the trivet and therefore prevent it from splattering onto the Stayclean finish.

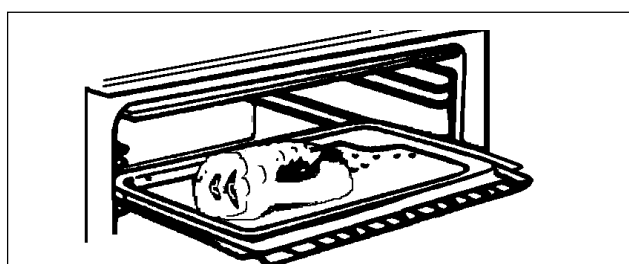
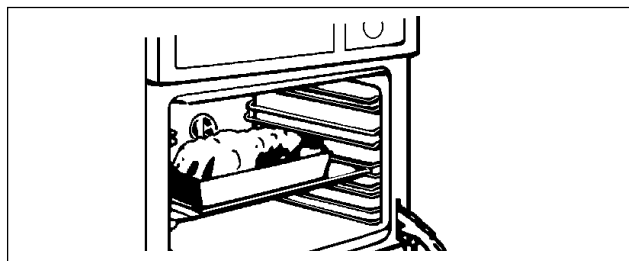
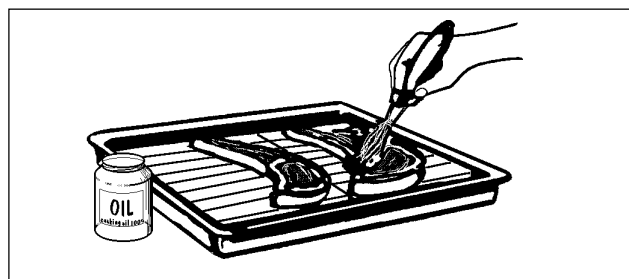

REPLACING THE OVEN LIGHT BULB

 **Isolate the cooker from the electricity supply before replacing the bulb.**

The type of bulb required is a 300°C, 25 watt small Edison Screw.

1. Make sure the cooker is cool before you replace a bulb.
2. Open the oven door and remove the shelves and wirework runners. Instructions on how to remove the wirework runners are given on page 38.
3. Pull the glass bulb cover towards you and then pull it off. If necessary use a screwdriver to carefully lever off the cover, taking care not to damage the oven cavity.
4. Unscrew the bulb by turning it to the left.
5. Fit a new bulb and then replace the glass bulb cover.
6. Refit the wirework runners and replace the oven shelves.
7. Restore the cooker to the electricity supply and reset the time of day.

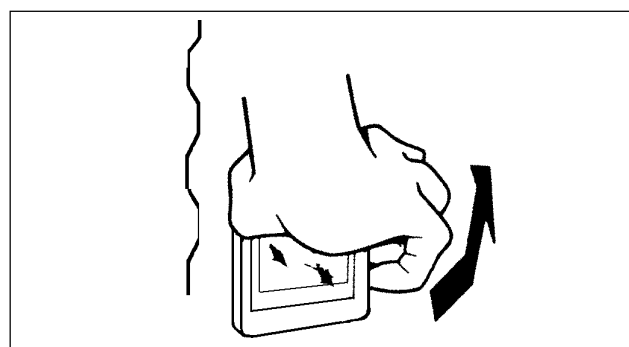

IF SOMETHING DOESN'T WORK

Please carry out the following checks on your cooker before calling a Service Engineer. It may be that the problem is a simple one which you can solve yourself without the expense of a service call.

If our Service Engineer finds that the problem is listed below you will be charged for the call whether or not the cooker is under guarantee.

PROBLEM	POSSIBLE SOLUTION
The grill, ovens and timer do not work	<p>Check that the cooker has been wired in to the cooker supply and is switched on at the wall.</p> <p>Check that the main cooker fuse is working.</p>
The Grill and Convenience Oven work but the Main Fan Oven does not.	<p>Check that the timer is set for manual operation. See page 11.</p> <p>Check that only the Grill control has been turned. If the Convenience Oven control has been turned it will override the grill.</p> <p>Ensure that the grill door is open when grilling. Leave the grill door open and allow the grill to cool. After a couple of hours check that the grill works as normal.</p> <p>Ensure the cooling fan is running when the grill is on. If the cooling fan fails, the grill will cycle on and off. Contact your nearest Service Centre.</p>
The timer does not work	<p>Check that the instructions for the operation of the timer are being closely followed.</p>
The indicator neons are not working correctly	<p>Check that you have selected only the function you require. Ensure all other controls are in the Off 'O' position.</p>
The oven is not cooking evenly	<p>Check that the cooker is correctly installed and is level.</p> <p>Check that the recommended temperatures and shelf positions are being used.</p>

The oven light fails to illuminate

The oven light bulb may need replacing see page 40.

If the Main Fan Oven is set for automatic cooking the light will illuminate when the cook time begins.

The oven fan is noisy

Check that the oven is level.

Check that shelves and bakeware are not vibrating in contact with the oven back panel.

The oven temperature is too high or low

Check that the recommended temperatures and shelf positions are being used. See pages 23 & 31. Be prepared to adjust up or down by 10°C to achieve the results you want.

GUARANTEE CONDITIONS

Standard guarantee conditions

We, Tricity Bendix, undertake that if within 12 months of the date of the purchase this Tricity Bendix appliance or any part thereof is proved to be defective by reason only of faulty workmanship or materials, we will, at our option repair or replace the same FREE OF CHARGE for labour, materials or carriage on condition that:

- The appliance has been correctly installed and used only on the electricity supply stated on the rating plate.
- The appliance has been used for normal domestic purposes only, and in accordance with the manufacturer's instructions.
- The appliance has not been serviced, maintained, repaired, taken apart or tampered with by any person not authorised by us.
- All service work under this guarantee must be undertaken by a Tricity Bendix service centre.
- Any appliance or defective part replaced shall become the Company's property.
- This guarantee is in addition to your statutory and other legal rights.

Home visits are made between **8.30am** and **5.30pm** Monday to Friday. Visits may be available outside these hours in which case a **premium** will be charged.

Exclusions

This guarantee does not cover:

- Damage or calls resulting from transportation, improper use or neglect, the replacement of any light bulbs or removable parts of glass or plastic.
- Costs incurred for calls to put right an appliance which is improperly installed or calls to appliances outside the United Kingdom.
- Appliances found to be in use within a commercial environment, plus those which are subject to rental agreements.
- Products of Tricity Bendix manufacture which are not marketed by Tricity Bendix.

European Guarantee

If you should move to another country within Europe then your guarantee moves with you to your new home subject to the following qualifications:

- The guarantee starts from the date you first purchased your product.
- The guarantee is for the same period and to the same extent for labour and parts as exists in the new country of use for this brand or range of products.
- This guarantee relates to you and cannot be transferred to another user.
- Your new home is within the European Community (EC) or European Free Trade Area.
- The product is installed and used in accordance with our instructions and is only used domestically, i.e. a normal household.
- The product is installed taking into account regulations in your new country.

Before you move please contact your nearest Customer Care centre, listed below, to give them details of your new home. They will then ensure that the local Service Organisation is aware of your move and able to look after you and your appliances.

France	Senlis	+33 (0)3 44 62 28 28
Germany	Nürnberg	+49 (0)911 323 2600
Italy	Pordenone	+39 (0)1678 47053
Sweden	Stockholm	+46 (0)20 78 77 50
UK	Newbury	+44 (0)1635 525 542

HELP US TO HELP YOU

Please determine your type of enquiry before writing or telephoning.

SERVICE

It is a recommendation by the manufacturer that annual servicing of the product is done by the manufacturers approved service organisation.

In the event of your appliance requiring service, or if you wish to purchase spare parts please contact your local Tricity Bendix Service Force Centre by telephoning:

0990 929929

The address of your local Service Force Centre is detailed on the following pages headed Tricity Bendix Service Force.

Before calling out an engineer, please ensure you have read the details under the heading 'Something Not Working?' and have the model number and purchase date to hand.

Please note that all enquiries concerning service should be addressed to your local Service Centre.

CUSTOMER CARE DEPARTMENT

For general enquiries concerning your Tricity Bendix cooker or for further information on Tricity Bendix products, you are invited to contact our Customer Care Department by letter or telephone as follows:

Customer Care Department
Tricity Bendix
PO Box 47
Newbury
Berkshire
RG14 5XL

Tel: (01635) 525542

To contact your local Tricity Bendix Service Centre telephone **0990 929929**

CHANNEL ISLANDS

GUERNSEY	Guernsey Electricity PO Box 4 Vale, Guernsey Channel Islands
JERSEY	Jersey Electricity Company PO Box 45 Queens Road St Helier Jersey Channel Islands JE4 8NY

SCOTLAND

ABERDEEN (M05)	8 Cornhill Arcade Cornhill Drive Aberdeen AB2 5UT
AUCHTERMUCHY (M03)	33A Burnside Auchtermuchy Fife KY14 7AJ
BLANTYRE (M07)	Unit 5 Block 2 Auchenraith Ind Estate Rosendale Way Blantyre G72 0NJ
DUMFRIES (M01)	93 Irish Street Dumfries Scotland DG1 2PQ
DUNOON (M67)	Briar Hill 7 Hill Street, Dunoon Argyll PA23 7AL
GLASGOW (M04)	20 Cunningham Road Clyde Estate Rutherglen, Glasgow, G73 1PP
INVERNESS (M06)	Unit 3B Smithton Indust. Est. Smithton Inverness IV1 AJ
ISLE OF ARRAN (OWN SALES)	Arran Domestics Unit 4 The Douglas Centre Brodict Isle of Arran KA27 8AJ
ISLE OF BARRA (OWN SALES)	J Zerfah 244 Bruernish Isle of Barra Western Islands HS9 5QY
ISLE OF BUTE (M66)	Walker Engineering Glenmhor Upper Serpentine Road Rothsay Isle of Bute PA20 9EH
ISLE OF LEWIS (M69)	ND Macleod 16 James Street Stornoway Isle of Lewis PA87 2QW
KELSO (M08)	2-8 Wood Market Kelso Borders TD5 7AX

ORKNEY (M65)	Corsie Domestics 7 King Street Kirkwall Orkney KW15
SHETLAND (OWN SALES)	Tait Electronic Systems Ltd. Holmsgarth Road Lerwick Shetland ZE1 0PW
SHETLAND (OWN SALES)	Bolts Shetland Ltd 26 North Road Lerwick Shetland ZE1 0PE
WHALSAY (OWN SALES)	Leask Electrical Harlsdale Symbister, Whalsay Shetland ZE2 9AA

NORTHERN IRELAND

BELFAST (M27)	Owenmore House Kilwee Industrial Estate Upper Dunmury Lane Belfast BT17 0HD
------------------	---

WALES

CARDIFF (M28)	Guardian Industrial Estate Clydesmuir Road Tremorfa, Cardiff CF2 2QS
CLYWD (M14)	Unit 6-7 Coed - Parc Abergele Road Rhuddlan Clwyd Wales LL18 5UG
DYFED (M77)	Maes Y Coen High Mead Llanybydder Dyfed SA40 9UL
HAVERFORDWEST (M75)	Cromlech Lodge Ameriston Haverfordwest SA62 5DS
OSWESTRY (M17)	Plas Ffynnon Warehouse Middleton Road Oswestry SY11 2PP

NORTH EAST

GATESHEAD (M39)	Unit 356a Dukesway Court Dukesway Team Valley Gateshead NE11 0BH
GRIMSBY (M42)	Unit 2 Cromwell Road Grimsby South Humberside DN31 2BN
HULL (M41)	Unit 1 Boulevard Industrial Estate Hull HU3 4AY
LEEDS (M37)	64-66 Cross Gates Road Leeds LS15 7NN
NEWTON AYCLIFFE (M45)	Unit 16 Gurney Way Aycliffe Ind Estate Newton Aycliffe DL5 6UJ
SHEFFIELD (M38)	Pennine House Roman Ridge Ind. Roman Ridge Road Sheffield S9 1GB

NORTH WEST

BIRKENHEAD (M11)	1 Kelvin Park Dock Road Birkenhead L41 1LT
CARLISLE (M10)	Unit 8 South John Street Carlisle CA2 5AJ
ISLE OF MAN (M64)	South Quay Ind Estate Douglas Isle of Man
LIVERPOOL (M15)	Unit 1 Honeys Green Precinct Honeys Green Lane Liverpool L12 9JH
MANCHESTER (M09)	Unit 30, Oakhill Trading Estate Devonshire Road Worsley Manchester M28 3PT
PRESTON (M13)	Unit 250 Dawson Place Walton Summit Bamber Bridge Preston Lancashire PR5 8AL
STOCKPORT (M16)	Unit 20 Haigh Park Haigh Avenue Stockport SK4 1QR

To contact your local Tricity Bendix Service Centre telephone **0990 929929**

MIDLANDS

BIRMINGHAM (M18)	66 Birch Road East, Wyrley Road Industrial Estate Witton Birmingham B6 7DB
BOURNE (M44)	Manning Road Ind Estate Pinfold Road Bourne PE10 9HT
BRIDGNORTH (M72)	1 Underhill Street Bridgnorth Salop WV16 4BB
GLOUCESTER (M23)	101 Rycroft Street Gloucester GL1 4NB
HEREFORD (M31)	Unit 3 Bank Buildings Cattle Market Hereford HE4 9HX
HIGHAM FERRERS (M51)	The Old Barn Westfield Terrace Higham Ferrers NN10 8BB
ILKESTON (M43)	Unit 2 Furnace Road Ilkeston DE7 5EP
LEICESTER (M22)	Unit 7 Oaks Industrial Estate Coventry Road Narborough Leicestershire LE9 5GF
LINCOLN (M40)	Unit 8 Stonefield Park Clifton Street Lincoln LN5 8AA
NEWCASTLE LYME (M12)	UNDER 18-21 Croft Road Brampton Industrial Estate Newcastle under Lyme Staffordshire ST5 0TW
NUNEATON (M21)	19 Ptarmigan Place Townsend Drive Nuneaton CV11 6RX
REDDITCH (M20)	13 Thornhill Road North Moons Moat Redditch Worcestershire B98 9ND
TAMWORTH (M19)	Unit 3 Sterling Park Claymore Tamworth B77 5DO
WORCESTER (M73)	Unit 1 Northbrook Close Gregorys Mill Ind Estate Worcester WR3 8BP

LONDON & EAST ANGLIA

CHELMSFORD (M47)	Hanbury Road Widford Ind Estate Chelmsford Essex CM12 3AE
COLINDALE (M53)	Unit 14 Capitol Park Capitol Way Colindale London NW9 0EQ
ENFIELD (M49)	284 Alma Road Enfield London EN3 7BB
GRAVESEND (M57)	Unit B4, Imperial Business Estate Gravesend Kent DA11 0DL
HARPENDEN (M46)	Unit 4 Riverside Estate Coldharbour Lane Harpenden AL5 4UN
LETCHEWORTH (M50)	16-17 Woodside Ind Est. Works Road Letchworth Herts SG6 1LA
MAIDENHEAD (M60)	Reform Road Maidenhead Berkshire SL6 8BY
MOLESEY (M61)	10 Island Farm Avenue West Molesey Surrey KT8 2UZ
NEWBURY (M24)	PO Box 5627 Newbury Berkshire RG14 5GF
IPSWICH (M48)	Unit 2B Elton Park Business Centre Hadleigh Road Ipswich IP2 0DD
NORWICH (M52)	2b Trafalgar Street Norwich NR1 3HN
SUNBURY (M63)	Unit 1a The Summit Hanworth Road Hanworth Ind Estate Sunbury on Thames TW16 5D
SYDENHAM (M62)	Unit 6 Metro Centre Kangley Bridge Road Sydenham SE26
WEST DRAYTON (M76)	2 / 4 Royal Lane Yiewsley West Drayton Middlesex UB7 8DL

SOUTH EAST

ASHFORD (M58)	Unit 2 Bridge Road Business Estate Kent Bridge Road Ashford Kent TN2 1BB
FLEET (M59)	Unit 1 Redfields Industrial Estate Church Crookham Fleet Hampshire GU13 0RD
HAYWARDS HEATH (M55)	21-25 Bridge Road Haywards Heath Sussex RH16 1UA
TONBRIDGE (M56)	Unit 30 Deacon Trading Estate Morley Road Tonbridge Kent TN9 1RA

SOUTH WEST

BARNSTAPLE (M30)	P.O. Box 12 Barnstaple North Devon EX31 2YB
BOURNEMOUTH (M26)	63-65 Curzon Road Bournemouth Dorset BH1 4PW
BRIDGEWATER (M35)	6 Hamp Industrial Estate Bridgewater Somerset TA6 3NT
BRISTOL (M25)	11 Eldon Way Eldonwall Trading Bristol Avon BS4 3QQ
EMSWORTH (M33)	266 Main Road Southbourne Emsworth PO10 8JL
ISLE OF WIGHT (M34)	Unit 8 Enterprise Court Ryde Business Park Ryde Isle of Wight PO33 1DB
NEWTON ABBOT (M29)	Unit 2 Zealley Industrial Estate Kingsteignton Newton Abbot S. Devon TQ12 3TD
PLYMOUTH (M32)	16 Faraday Mill Cattledown Plymouth PL4 0ST
REDRUTH (M36)	Unit 7D Pool Industrial Estate Wilson Way, Redruth, Cornwall TR15 3QW

TECHNICAL DETAILS

Voltage: 230\240 Volts AC 50Hz

Loading Info:

Top Oven* 1.7kW

Dual Grill: 2.8kW

Base Element: 1.0kW

Main Oven
Fan Element: 2.5kW

Fan Motor: 0.03kW

Oven Light: 0.05kW

Wattage: 5.0\5.5kW

Height: 720 mm

Width: 593 mm

Depth: 585 mm
(excluding handles and knobs)

* Cannot be used at the same time as the grill element.

This appliance complies with: European Council Directive 73/23/EEC.
EMC Directive 89/336/EEC.
CE Marking Directive 93/68/EEC.

INSTALLATION INSTRUCTIONS

THINGS YOU NEED TO KNOW



WARNINGS:

WARNINGS:

- This cooker must be installed by a qualified electrician/competent person. Safety may be impaired if installation is not carried out in accordance with these instructions.
- This cooker must be earthed.
- Do not remove the screws from the earth tab extending from the oven mains terminal block (Fig. 1).
- Before connecting the cooker make sure that the voltage of your electricity supply is the same as that indicated on the rating plate. The rating plate can be seen by opening the top oven door and looking below the oven door seal.
- Do not alter the electrical circuitry of this cooker.

CHOICE OF ELECTRICAL CONNECTION

- The cooker should be operated using at least 6mm² twin core and earth PVC insulated multicore cable. Please choose from the most appropriate after reading the descriptions:
- By connecting the cooker to a cooker point having a double pole isolating switch providing at least 3mm contact separation in all poles and protected with a fuse or miniature circuit breaker at your mains fuse box.
- If you wish to connect an oven and a hob to a cooker point you can, by connecting the oven and hob separately to the cooker point. See Fig. 2.

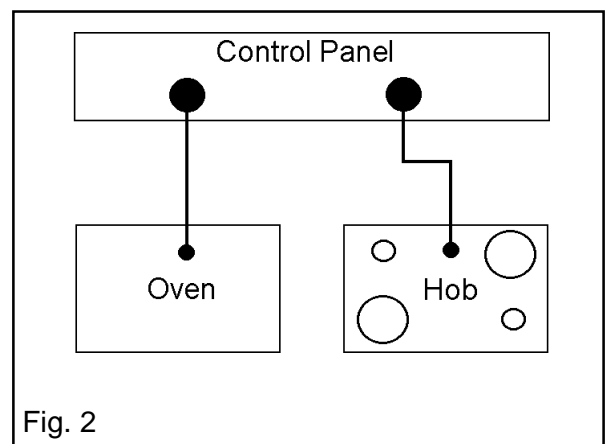
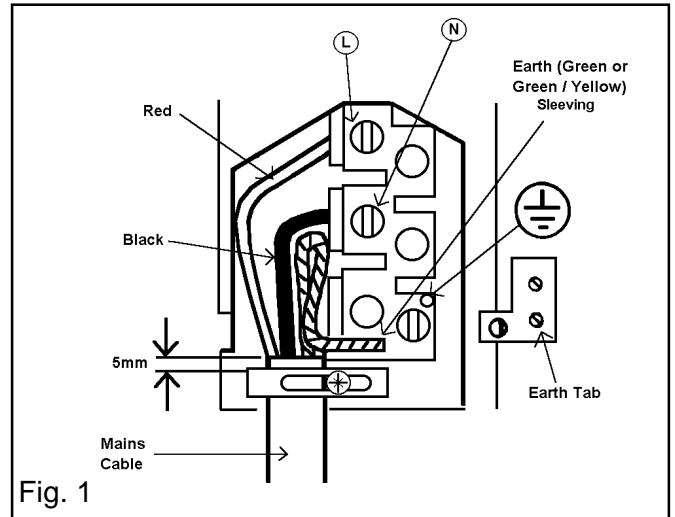

INSTALLATION INSTRUCTIONS

NOTE: It is good practice to:

- Fit an Earth Leakage Circuit Breaker to your house wiring.
- Wire your appliance to the latest IEE regulations.

THINGS TO NOTE

- This cooker is designed to be fitted between cabinets with the recommended dimensions as shown in Fig. 3 & 4.
- If there is an existing housing unit it must be removed.
- The dimensions given provide adequate air circulation around the unit within the cabinet, ensuring compliance with BS EN60-335.
- This appliance must not be installed on a wooden base board.
- Enquiries regarding the installation of the cooker point if required should be made to your Regional Electricity Company to ensure compliance with their regulations.
- The cooker point should be within 2m of the cooker to make it accessible to switch off the cooker in case of an emergency.
- To protect the hands wear gloves when lifting the oven into its housing.

NOTE: HOUSE CIRCUIT

Earth leakage / continuity tests must be carried out before the cooker is connected to the mains supply and re-checked after fitting.

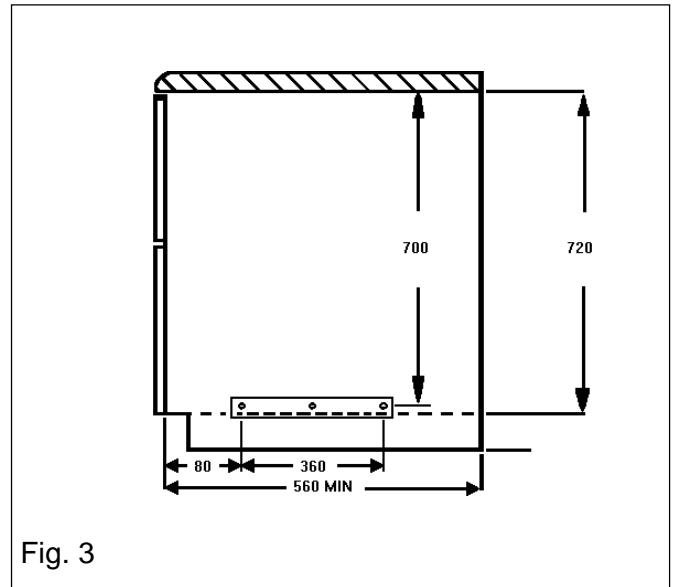

Fig. 3

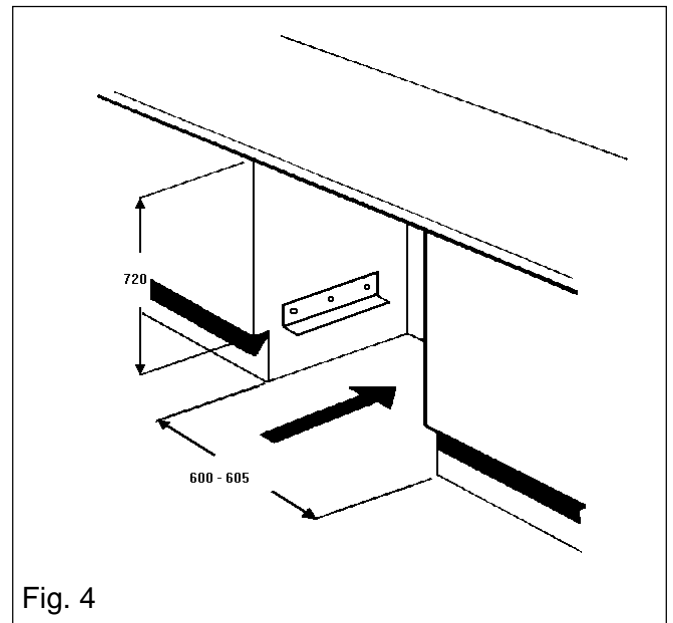

Fig. 4

INSTALLATION INSTRUCTIONS

PREPARING CABINET FOR FITTING OVEN

- Make sure the space between the cabinets is the correct size for the appliance to be fitted (Ref. Fig. 5 & 6).
- The plinth board spanning the space into which the appliance is to be installed should be removed.
- If the size between adjacent cabinets is 605-610*mm, then the cabinets should be modified so that the recommended dimension of at least 600-605mm is maintained.
- The adjacent cabinets must be stable and firmly secured to the wall or floor. If necessary, make arrangements to ensure the work surface below which the oven will rest is level.
- Drill two pilot screw holes into the sides of the adjacent cabinets, in the positions indicated by Fig. 5.

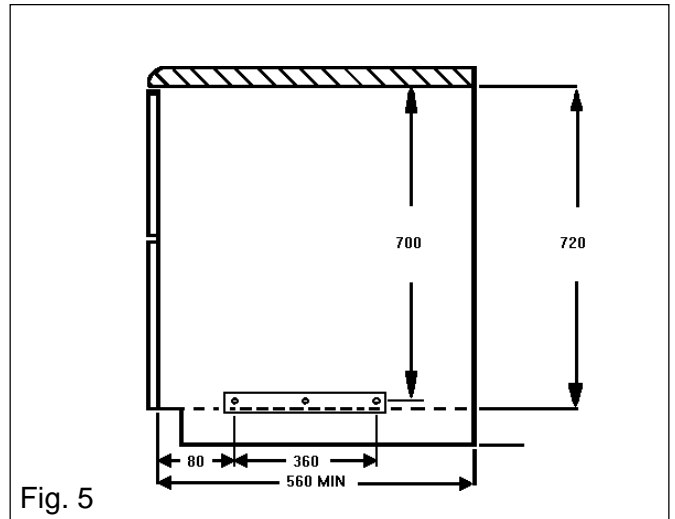

Fig. 5

- Drill two pilot screw holes into the sides of the adjacent cabinets, in the positions indicated by Fig. 5.

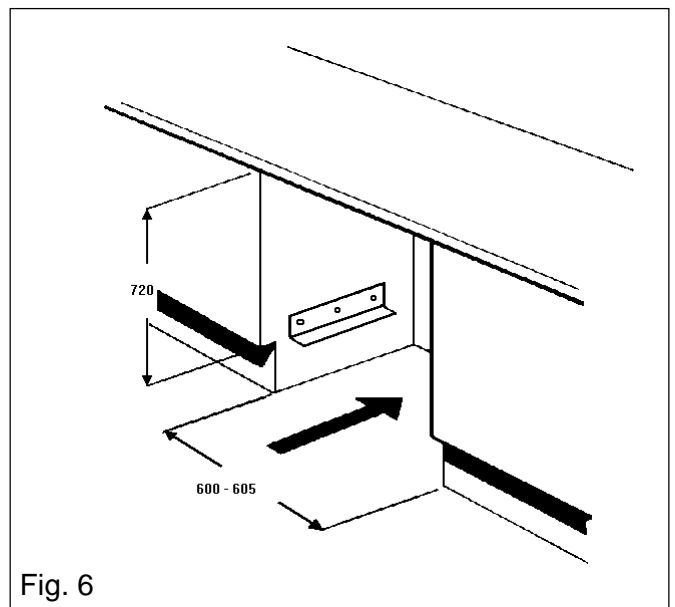

Fig. 6

- Fit the appliance mounting brackets using the two holes indicated in Fig. 7 to the adjacent cabinets (Ref. Fig.5 & 6)

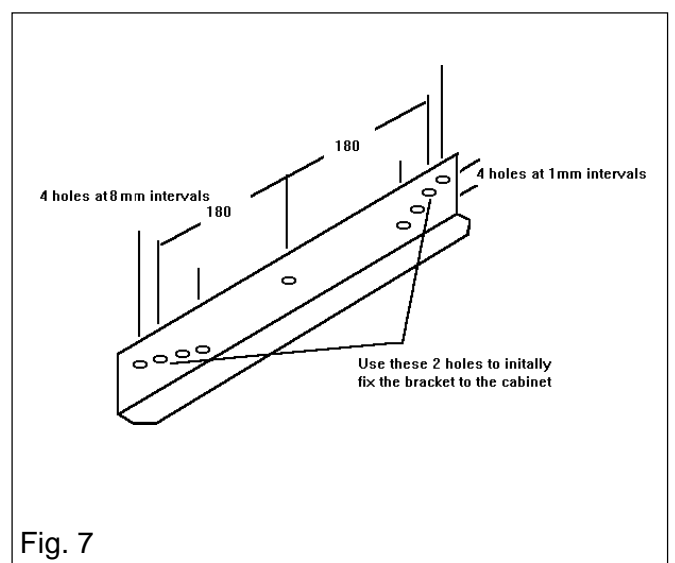

Fig. 7

INSTALLATION INSTRUCTIONS

- Check that the mounting brackets are level. They can be adjusted if necessary by using the extra holes at the ends of the brackets. Once the brackets are level, drill a pilot hole through the central hole in the bracket and fit the remaining screw

HOW TO FINISH UNPACKING

- Place packed cooker next to the space in which it will be installed. See Fig. 8.
- Remove the cooker packing except for bottom tray which should be left in position until the cooker is ready to be fitted into its cabinet.
- Ensure the owner is given these operating instructions.

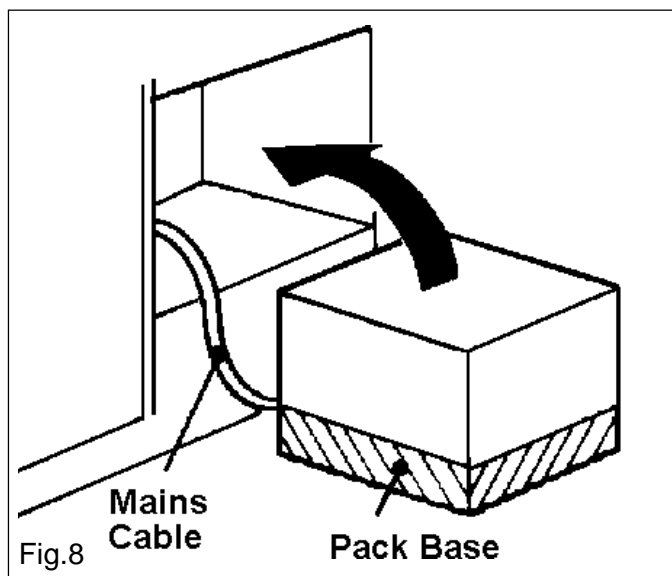

Important: Switch off at mains, miniature circuit breaker and, if appropriate, remove fuse before commencing any electrical work.

INSTALLATION INSTRUCTIONS

TO REMOVE COVER OF MAINS TERMINAL

From the rear of the cooker, remove mains input terminal cover to gain access to terminal block.

- First remove retaining screw with pozidrive screwdriver. See Fig. 9.

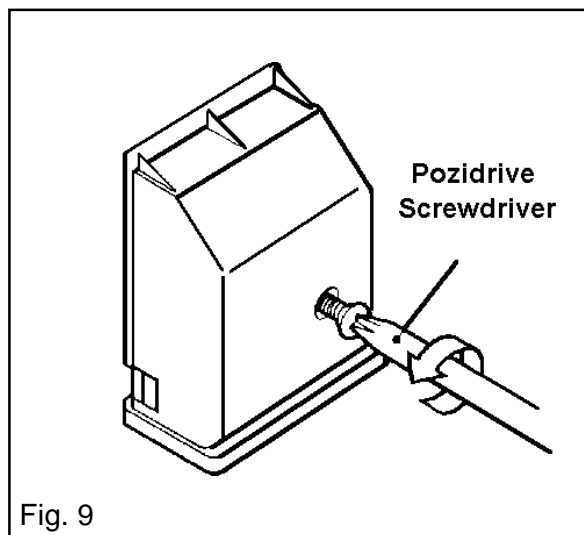

- Prise cover loose using screwdriver in position (1) then lever off with screwdriver in position (2) at either side. See Fig. 10.

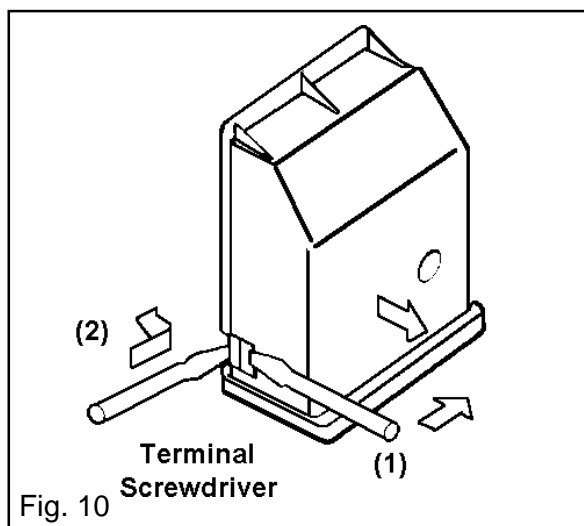

- Lift cover and remove screw from cable clamp. See Fig. 11.

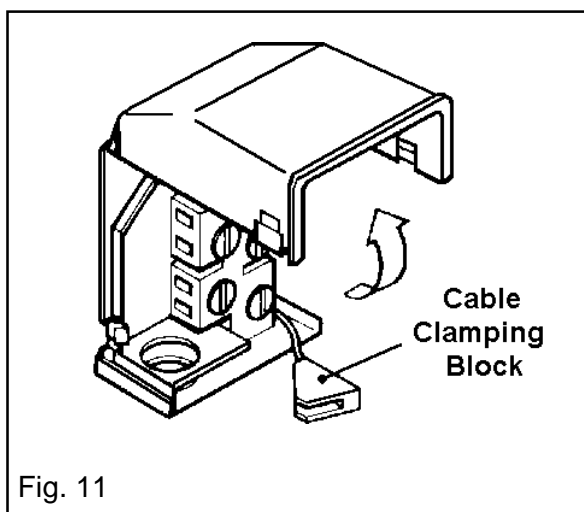

INSTALLATION INSTRUCTIONS

CONNECTING TO THE MAINS TERMINAL



Warning: This cooker must be earthed.

- We recommend you use a new length of 6mm² twin core and earthed cable to ensure your safety.
- Make connection as shown in Fig. 12 by proceeding as follows:-
- Preform wires to the appropriate shape to suit fitting into the mains terminal block.
- Strip inner insulation on wires using wirestrippers.
- Twist the bared wires using pliers.
- Cut bared wires 10mm away from the end of the inner insulation. Where uninsulated Earth wires are used ensure they are suitably sheathed to leave 10mm bare wire to fit into the terminal.
- Clamp bare wires into the relevant terminal and check they are held by tugging each one in turn.
- Clamp the mains cable securely ensuring 5mm of the outer insulation is inside the terminal block and that the wires are not taught but not so slack as to cause any fouling. See Fig. 12.
- Connect the remaining end of the mains cable to the cooker point / junction box
- Place fuse / miniature circuit breaker in circuit and switch on at mains.

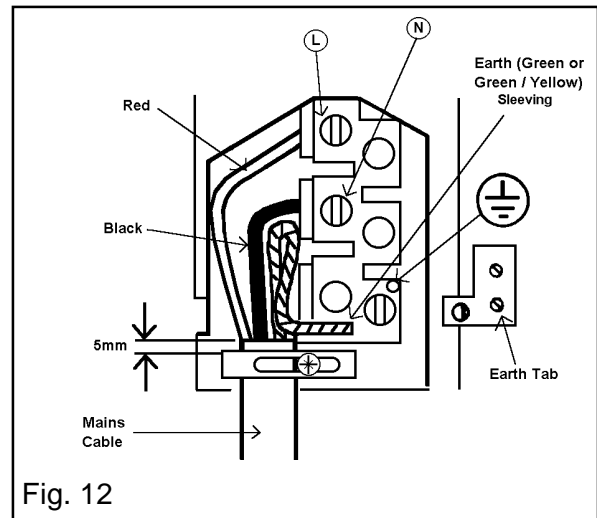

INSTALLATION INSTRUCTIONS

CHECKING ELECTRICAL CONNECTIONS

- Confirm the cooker is correctly connected by switching on and observing the various oven functions indicators.
- The electronic timer will flash on and off.

CONNECTING TO A HOB OR COOKER POINT

- Either follow in general terms the instructions for connecting to the terminal block or refer to the hob suppliers installation instructions.

Feed the cable through the cabinet and arrange to route the cable away from the cooker.

NOTE: HOUSE CIRCUIT

Earth leakage / continuity tests must be carried out before the cooker is connected to the mains supply and re-checked after fitting.

INSTALLATION INSTRUCTIONS

FITTING INTO THE SPACE BETWEEN CABINETS



IMPORTANT: Ensure that the oven is switched off at the wall before any further work is carried out.

- Ensure the cooker is in front of the cabinet. See Fig. 13.
- Take out all oven furniture before installation to reduce the weight you need to lift.
- To place the cooker into the space between cabinetry follow the procedure below:
- N.B. Two people will be required to carry out the lifting procedure. Each person should squat either side of the cooker. Tilt the cooker so that your hands can support the underside of the cooker. Raise the appliance to the correct height. Rest the rear underside of the cooker on the mounting brackets while your hands support the front. The cooker can be pushed fully into the space. Take care to avoid fouling the mains lead. Ensure the cooker is central and level.
- When the cooker is fully housed, screw the stability screws (supplied with the cooker) into the underside of the worksurface in the positions indicated (see Fig. 14), taking care not to distort the trim. It is advisable to turn each screw alternately to avoid damaging the trim.
- Place the top trim flush with the edge of the worksurface, with the cork spacers upover (see Fig.15) and screw into position using the screws supplied with the cooker.
- Replace the plinth board.
- Switch on the cooker and refer the user to the operating instructions.

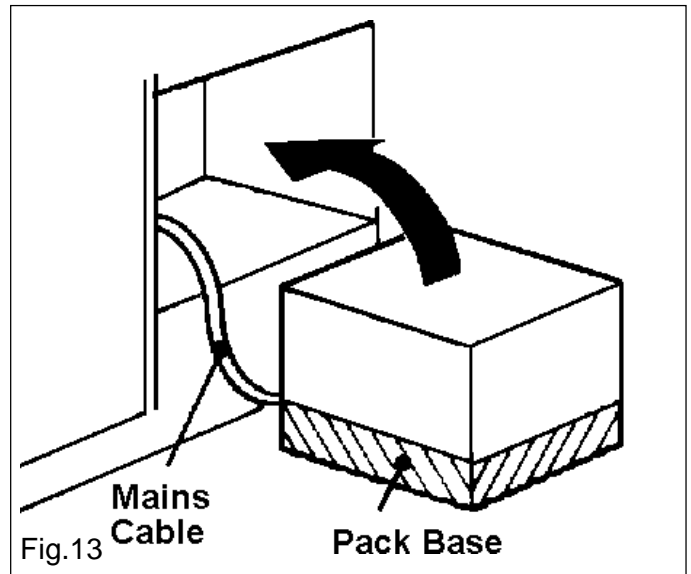

Fig.13

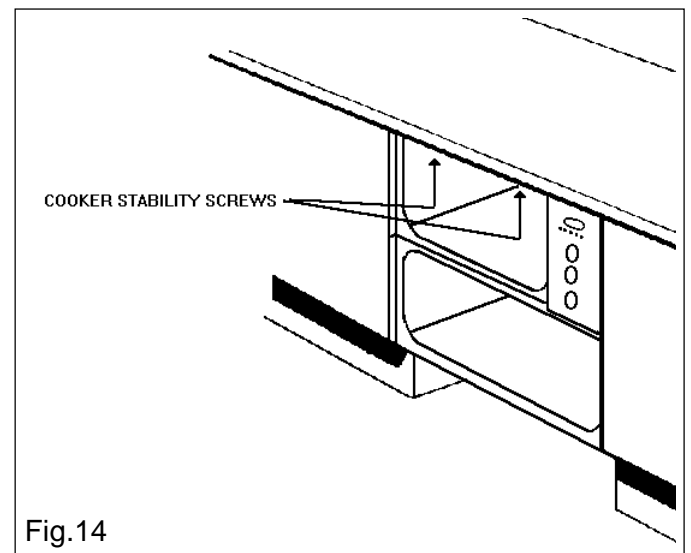

Fig.14

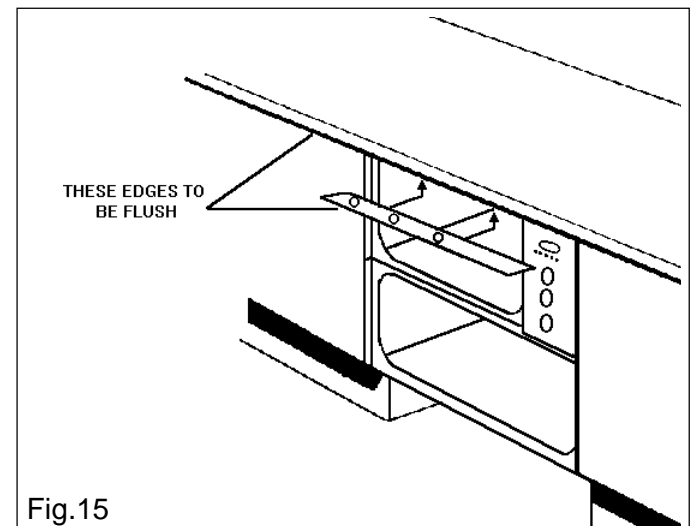

Fig.15

RATING PLATE REFERENCE

MAKE AND MODEL NO.	SERIAL NO.	DATE OF PURCHASE	PRODUCT NO.

IMPORTANT NOTICE

In line with our continuing policy of research and development, we reserve the right to alter models and specifications without prior notice.

This handbook is accurate at the date of printing, but will be superseded and should be disregarded if specifications or appearance are changed.



TRICITY BENDIX, PO BOX 47, NEWBURY, BERKSHIRE, RG14 5XL
TELEPHONE (01635) 525542

MODEL NO.
E 750



PART NO.
311372501

1998