

Table of Contents

GB-IE

1. PRECAUTIONS FOR USE.....	34
2. DISPOSAL INSTRUCTIONS - OUR ENVIRONMENT POLICY	35
3. SAFETY PRECAUTIONS.....	36
4. GET TO KNOW YOUR OVEN	37
5. BEFORE INSTALLATION	38
6. DESCRIPTION OF FRONT PANEL CONTROLS	39
7. USING THE OVEN.....	41
8. USING THE PIZZA FUNCTION	42
9. USING THE TOAST FUNCTION	43
10. ELECTRONIC PROGRAMMER.....	45
11. ACCESSORIES AVAILABLE	48
12. COOKING TABLES.....	50
13. CLEANING AND MAINTENANCE	53
14. EXTRAORDINARY MAINTENANCE	58
15. INSTALLING THE APPLIANCE	61



INSTRUCTIONS FOR THE USER: *these provide recommendations for use, a description of the controls and the correct procedures for cleaning and maintaining the appliance*



INSTRUCTIONS FOR THE INSTALLER: *these are intended for the qualified engineer who is to install, commission and test the appliance*

1. PRECAUTIONS FOR USE



THIS MANUAL IS AN INTEGRAL PART OF THE APPLIANCE. TAKE GOOD CARE OF IT AND KEEP IT TO HAND THROUGHOUT THE OVEN'S LIFE CYCLE. WE URGE YOU TO READ THIS MANUAL AND ALL THE INFORMATION IT CONTAINS CAREFULLY BEFORE USING THE APPLIANCE. INSTALLATION MUST BE CARRIED OUT BY QUALIFIED STAFF IN COMPLIANCE WITH THE RELEVANT REGULATIONS. THIS APPLIANCE IS INTENDED FOR HOUSEHOLD USE AND COMPLIES WITH THE EEC DIRECTIVES CURRENTLY IN FORCE. THE APPLIANCE IS BUILT TO PROVIDE THE FOLLOWING FUNCTION: COOKING AND HEATING FOODS; ALL OTHER USES ARE TO BE CONSIDERED IMPROPER. THE MANUFACTURER DECLINES ALL LIABILITY FOR USES OTHER THAN THOSE STATED ABOVE.



NEVER USE THIS APPLIANCE FOR HEATING ROOMS.



NEVER LEAVE PACKAGING RESIDUES UNATTENDED IN THE HOME. SEPARATE THE VARIOUS PACKAGING MATERIALS BY TYPE AND CONSIGN THEM TO THE NEAREST SEPARATE DISPOSAL CENTRE.



THIS APPLIANCE IS TAGGED UNDER EUROPEAN DIRECTIVE 2002/96/EC ON WASTE ELECTRICAL AND ELECTRONIC EQUIPMENT (WEEE). THIS DIRECTIVE CONTAINS THE REGULATIONS GOVERNING THE COLLECTION AND RECYCLING OF DECOMMISSIONED APPLIANCES THROUGHOUT THE EUROPEAN UNION.



NEVER OBSTRUCT THE OPENINGS AND SLITS PROVIDED FOR VENTILATION AND HEAT DISPERSAL.



THE NAMEPLATE WITH THE TECHNICAL DATA, SERIAL NUMBER AND MARK IS IN A VISIBLE POSITION ON THE OVEN DOOR FRAME. THE NAMEPLATE MUST NEVER BE REMOVED.



NEVER USE METAL SCOURING PADS OR SHARP SCRAPERS; THEY WILL DAMAGE SURFACES. USE ORDINARY NON-ABRASIVE PRODUCTS WITH THE AID OF WOODEN OR PLASTIC UTENSILS IF NECESSARY. RINSE THOROUGHLY AND DRY WITH A SOFT CLOTH OR CHAMOIS LEATHER.

DO NOT ALLOW SPILLS OF FOODS WITH HIGH SUGAR CONTENT (E.G. JAM) TO DRY INSIDE THE OVEN. IF THEY DRY FOR TOO LONG, THEY MIGHT DAMAGE THE ENAMEL COATING OF THE INSIDE OF THE OVEN.





Disposal instructions

GB-IE

2. DISPOSAL INSTRUCTIONS - OUR ENVIRONMENT POLICY

Our products are only packaged using non-pollutant, environment-friendly, recyclable materials. We urge you to cooperate by disposing of the packaging properly. Contact your local dealer or the competent local organisations for the addresses of collection, recycling and disposal facilities.

Never leave all or part of the packaging lying around. Packaging parts, and especially plastic bags, may represent a suffocation hazard for children.

Your old appliance must also be disposed of properly.

Important: deliver the appliance to your local organisation authorised to collect scrapped appliances. Proper disposal allows the intelligent recovery of valuable materials.

Before scrapping your appliance it is important to remove doors and leave shelves in position as for use, to ensure that children cannot accidentally become trapped inside the oven during play. Also, cut the power supply lead and remove it and the plug.

3. SAFETY PRECAUTIONS



REFER TO THE INSTALLATION INSTRUCTIONS FOR THE SAFETY REGULATIONS FOR ELECTRIC OR GAS APPLIANCES AND VENTILATION FUNCTIONS.

IN YOUR INTEREST AND TO ENSURE YOUR SAFETY, BY LAW ALL ELECTRIC APPLIANCES MUST ONLY BE INSTALLED AND SERVICED BY QUALIFIED STAFF, IN ACCORDANCE WITH THE RELEVANT REGULATIONS. OUR APPROVED INSTALLATION ENGINEERS GUARANTEE YOU A JOB WELL DONE.

GAS OR ELECTRIC APPLIANCES MUST ALWAYS BE DISCONNECTED BY SUITABLY SKILLED PEOPLE.



THE PLUG TO BE CONNECTED TO THE POWER SUPPLY LEAD AND THE RELATIVE SOCKET MUST BE OF THE SAME TYPE AND COMPLY WITH THE RELEVANT REGULATIONS.

THE POWER SUPPLY SOCKET MUST BE ACCESSIBLE EVEN AFTER THE APPLIANCE HAS BEEN BUILT-IN.

NEVER DISCONNECT THE PLUG BY PULLING ON THE POWER SUPPLY LEAD.



THE APPLIANCE MUST BE CONNECTED TO EARTH IN COMPLIANCE WITH ELECTRICAL SYSTEM SAFETY REGULATIONS.



IMMEDIATELY AFTER INSTALLATION, CARRY OUT A QUICK TEST ON THE APPLIANCE FOLLOWING THE INSTRUCTIONS PROVIDED LATER IN THIS MANUAL. IF THE APPLIANCE FAILS TO OPERATE, DISCONNECT IT FROM THE ELECTRICAL MAINS AND CONTACT YOUR NEAREST SERVICE CENTRE. NEVER ATTEMPT TO REPAIR THE APPLIANCE.



NEVER PLACE INFLAMMABLE OBJECTS IN THE OVEN: IF IT SHOULD ACCIDENTALLY BE SWITCHED ON, THIS MIGHT CAUSE A FIRE.



THE APPLIANCE BECOMES VERY HOT DURING USE. TAKE CARE NOT TO TOUCH THE HEATING ELEMENTS INSIDE THE OVEN.



THE USE OF THIS APPLIANCE IS NOT PERMITTED TO PEOPLE (INCLUDING CHILDREN) OF REDUCED PHYSICAL AND MENTAL ABILITY, OR LACKING IN EXPERIENCE IN THE USE OF ELECTRICAL APPLIANCES, UNLESS THEY ARE SUPERVISED OR INSTRUCTED BY ADULTS OR PEOPLE RESPONSIBLE FOR THEIR SAFETY.



BEFORE THE APPLIANCE IS PUT INTO OPERATION, ALL THE PROTECTIVE FILMS APPLIED ON THE OUTSIDE MUST BE REMOVED.



The manufacturer declines all responsibility for injury or damage caused by failure to comply with the above regulations or deriving from tampering with even just one part of the appliance and the use of non-original spare parts.



Instructions for the User

GB-IE

4. GET TO KNOW YOUR OVEN

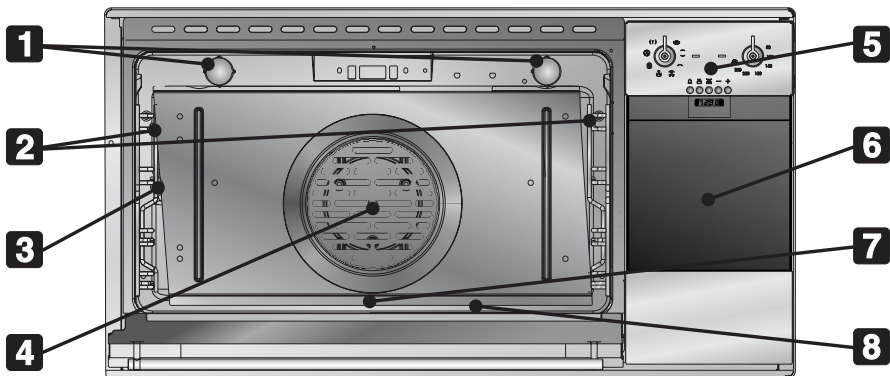

DESCRIPTION OF OVENS

- | | | |
|------------------------------------|-----------------------------|---------------------------|
| 1 OVEN LIGHTS | 2 OVEN SHELF RUNNERS | 3 ROTISSERIE MOTOR |
| 4 OVEN FAN | 5 CONTROL PANEL | 6 TOASTER DRAWER |
| 7 PIZZA PLATE LIFTING LEVER | 8 PIZZA PLATE CAVITY | |

DESCRIPTION OF TOASTER

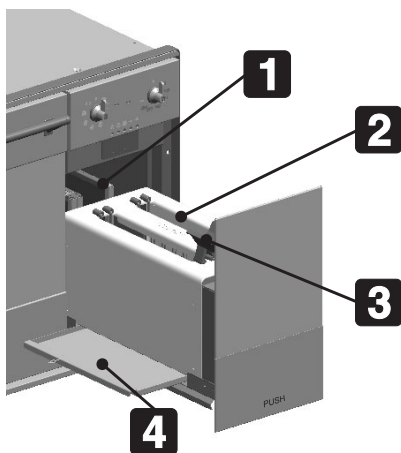

- | |
|------------------------------|
| 1 HEATING UNITS |
| 2 TOASTER RACK SLOTS |
| 3 TOASTER RACKS |
| 4 CRUMB TRAY |
| 5 TOASTER PILOT LIGHT |



5. BEFORE INSTALLATION



Never leave packaging residues unattended in the home. Separate waste packaging materials by type and consign them to the nearest separate disposal centre.



The inside of the appliance should be cleaned to remove all manufacturing residues. For further information about cleaning, see point "13. CLEANING AND MAINTENANCE".

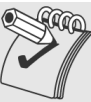

When the oven and toaster are used for the first time, they should be heated (with no food inside) to the maximum temperature for long enough to burn off any oily residues left by the manufacturing process, which might contaminate foods with unpleasant smells.

Heat the toaster for the programmer maximum time setting (10 minutes). After an interruption in the electricity supply, the programmer display flashes at regular intervals. For setting instructions, see point "10.1 Setting the time".



Instructions for the User

GB-IE

6. DESCRIPTION OF FRONT PANEL CONTROLS

All the appliance's control and monitoring devices are placed together on the front panel. The table below provides the key to the symbols used.

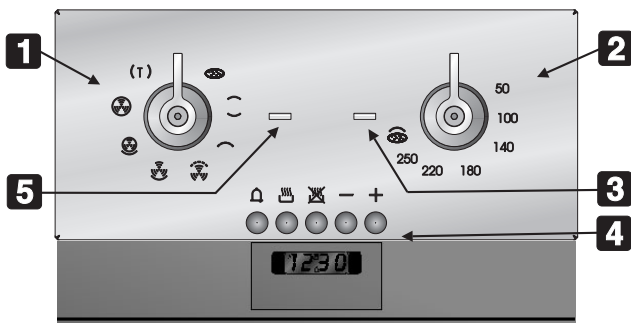

1

FUNCTION SELECTOR KNOB

Turn the knob either way to select one of the following functions:



PIZZA FUNCTION (ON SOME MODELS ONLY)



TOP + BOTTOM HEATING ELEMENTS



GRILL ELEMENT + TOP HEATING ELEMENT



GRILL ELEMENT + FAN



BOTTOM HEATING ELEMENT + FAN (ON SOME MODELS ONLY)



BOTTOM + ROUND HEATING ELEMENTS



ROUND HEATING ELEMENT



TOASTER INTERNAL HEATING ELEMENTS

Instructions for the User



2

THERMOSTAT KNOB

The cooking temperature is selected by turning the knob clockwise to the required setting, between **50°** and **250°** for normal settings and to the symbol  for the pizza oven setting.

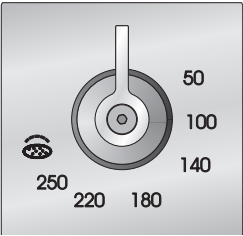

3

THERMOSTAT LIGHT

Lights up to indicate that the oven is heating up. Goes out when the set temperature is reached. Flashes at regular intervals to indicate that the temperature inside the oven is being kept constantly at the set level.

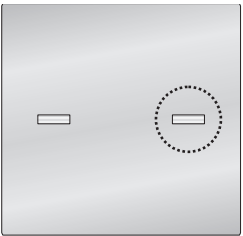

4

ELECTRONIC PROGRAMMER

This electronic device can be used to programme alarms, cooking times and oven on/off times. For more information, see point "10. ELECTRONIC PROGRAMMER".

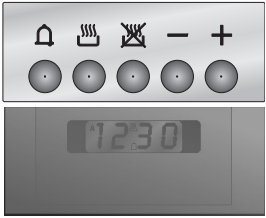

5

TOASTER PILOT LIGHT

Lights up to indicate that the toaster is in operation. This light comes on whenever the function selector knob is turned to the toast function and goes out when the knob is turned to zero, at the end of the cooking time or in any other function.

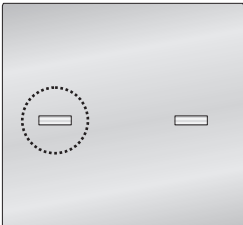



Instructions for the User

GB-IE

7. USING THE OVEN

7.1 Precautions and General Advice



All cooking operations must be carried out with the door closed.

When the oven and toaster are used for the first time, they should be heated to the maximum temperature for long enough to burn off any oily residues left by the manufacturing process, which might contaminate foods with unpleasant smells.



During cooking, do not cover the bottom of the oven with aluminium or tin foil, and do not place pans or trays on it; this may damage the enamel coating. If you wish to use greaseproof paper, position it so that it does not interfere with the hot air circulation inside the oven.



Oven accessories which may come into contact with foods are made from materials compliant with directive 89/109/EEC of 21/12/88 and relevant national regulations.



To avoid unpleasant contact with any steam inside the oven, open the door in two stages: hold it half-open (about 5 cm) for 4-5 seconds, then open it completely. If you have to carry out any procedures on foods, leave the door open for as short a time as possible to prevent a drop in the oven temperature which will impair the cooking results.



To prevent excessive amounts of condensation from forming on the internal glass, food should not be left inside the oven for too long after cooking.

7.2 Cooling fan system

The appliance is equipped with a cooling system which comes into operation as soon as a cooking function starts. Operation of the fan generates a normal air flow which comes out above the door and may continue for a short time even after the oven is turned off.

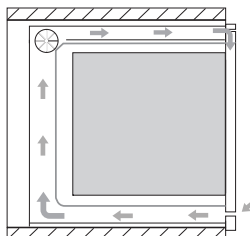

7.3 Inside lights



The oven lights come on when any function is set except for the (T) (Toast) function.

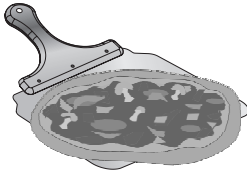

8. USING THE PIZZA FUNCTION

This appliance is equipped with a function specially developed for cooking pizza with the special plate provided. This function is identified by the  symbol on the oven functions knob. To cook a pizza, proceed as described below.



Set the oven functions knob on the  symbol and the thermostat knob on the  symbol.

Preheat with these settings until the thermostat light goes out, then place the pizza on the special plate using the pizza shovel provided. It does not normally take more than 3-4 minutes to cook a pizza to perfection,

although this time may vary depending on the dough used or individual taste.

8.1 Precautions for using the pizza plate

- Never use the pizza plate except as described above (for example, never use it on gas or ceramic hobs, or on ovens not designed to take this accessory).
- For conventional cooking operations, it is advisable to remove the pizza plate and replace it with the bottom cover provided.
- If you like oil on your pizza, it is best to add it after removal from the oven since oil stains on the pizza plate are unsightly and may reduce its efficiency.



Never use any oven function if the pizza plate or cover is not in position.

8.2 To save energy

The pizza stone acts as a heat reservoir. This allows energy consumption to be reduced, especially in cooking operations requiring medium-long times. In these cases, simply switch the oven off 10-12 minutes before the end of the cooking time. The heat gradually emitted by the refractory stone will ensure that the cooking temperature is maintained.



Instructions for the User

GB-IE

9. USING THE TOAST FUNCTION

This appliance is equipped with a compartment specially developed for toasting bread and sandwiches. This function is identified by the (T) symbol on the oven functions knob.

To toast foods in the toaster proceed as described below:

- 1 Release the toaster by pressing on its lower side.
- 2 Pull the toaster towards you to open it.
- 3 Once the toaster is open, take hold of the racks by the handles and lift them out.
- 4 Fit the bread or sandwiches for toasting in the racks. (each rack can take up to 2 toasted sandwiches).
- 5 Put the racks back in their slots.
- 6 Push the drawer back into the toaster until you hear the catch click into place.

The food can now be toasted. Turn the function selector knob to the (T) symbol. This activates the toasting function. The cooking time (up to 10 minutes) can be set using the programmer (see programmer section).

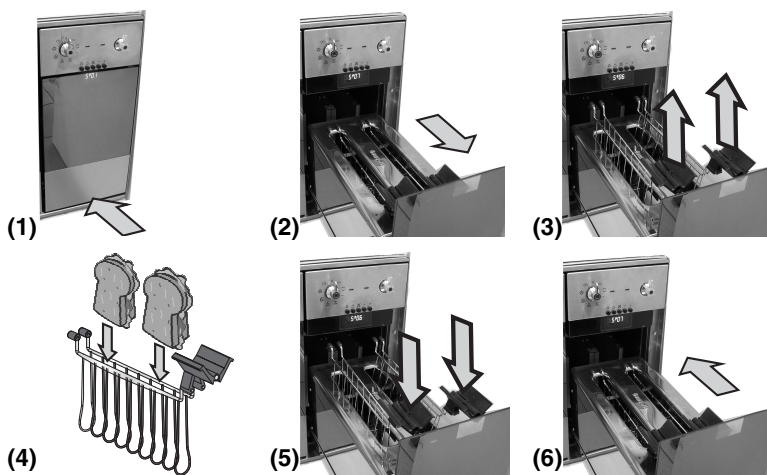

When in operation, take great care not to touch the toaster compartment or heating elements: they might still be hot even a few minutes after use.

Instructions for the User



9.1 *Precautions for use of the toaster*

- Never remove the slot structure inside the toaster
- Never use the toaster in any way other than that described.
- Never touch the heating elements inside the toaster after use for cooking.
- Never carry out more than 10 consecutive toasting cycles. This might seriously damage the appliance and put its safety at risk. Wait at least one minute with the toaster open between one cycle and the next.





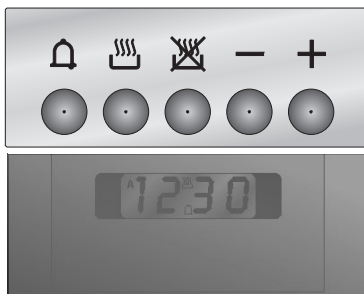

Instructions for the User

GB-IE

10. ELECTRONIC PROGRAMMER





LIST OF FUNCTIONS

-  TIMER BUTTON
-  COOKING DURATION BUTTON
-  END OF COOKING BUTTON
-  VALUE DECREASE BUTTON
-  VALUE INCREASE BUTTON

10.1 *Setting the time*

When the oven is used for the first time, or after an interruption in the electricity supply, the display flashes at regular intervals, showing

0:00

. Press  to stop the display flashing. Press the value modification keys  or  within 5 seconds to increase or decrease the setting by one minute for each pressure.

Press one of the two value modification keys until the current time appears.









Before each programmer setting, switch on the function and set the temperature required. When using the toaster, simply switch on the toast function.



10.2 Semiautomatic cooking





This function only switches the oven or toaster off automatically at the end of the cooking time.



Press the  key and the display will light up showing the figures ; keep it pressed, and at the same time use the value modification keys  or  to set the cooking duration.



A few seconds after the  key is released, the count of the programmed cooking duration will start and the display will show the current time together with the symbols **A** and .

10.3 Automatic cooking



This function switches the oven or toaster on and off in fully automatic mode.

Press the  key and the display will light up showing the figures ; keep it pressed, and at the same time use the value modification keys  or  to set the cooking duration.





Press the  key and the display will show the sum of the current time plus the cooking duration just set: keep it pressed, and at the same time use the value modification keys  or  to adjust the cooking end time.

A few seconds after the  key is released, the programmed count will start and the display will show the current time together with the symbol **A**. When the cooking start time calculated automatically by the programmer on the basis of the data entered is reached, the display will show the **A** and  symbols together.



After the setting, to view the cooking time left press the  key; to view the cooking end time press the  key. The logic prevents the setting of incompatible values (e.g. the timer will not accept a cooking end time with a duration which is too long for this value).

10.4 Timer

The programmer can also be used as an ordinary timer. Press the  key and the display will show the figures ; keep it pressed and simultaneously press the value modification keys  or . When the key is released the programmed count will start and the display will show the current time and the symbol .



*After the setting, to display the time left press the  key.
In timer mode, the system will not cut out operation of the oven at the end of the set time.*



Instructions for the User

GB-IE

10.5 End of cooking



At the end of the cooking time the oven or toaster will switch off automatically and simultaneously (except for the toaster function) a buzzer will start to sound in on-off mode.

After the buzzer is stopped, the display will return to showing the current time together with the  symbol, indicating that the oven is again ready for use in manual mode.





10.6 Adjusting the buzzer volume

The buzzer volume can be varied (3 settings) while it is in operation by pressing .





10.7 Stopping the buzzer

The buzzer stops automatically after seven minutes. It can be stopped in manual mode by pressing the  and  keys together. To switch off the appliance, return all the knobs to the 0 setting in sequence.

10.8 Deleting the data set

With the program set, keep the key of the function for deletion ( or ) pressed, while at the same time setting the value  by pressing the value modification keys  or . The programmer will interpret deletion of the duration as the end of cooking.

10.9 Modifying the data set

The cooking data set can be modified at any moment by keeping the key of the function for modification ( or ) pressed and at the same time pressing the value modification keys  or .



11. ACCESSORIES AVAILABLE

The oven is fitted with 4 runners for placing trays and shelves at different heights.

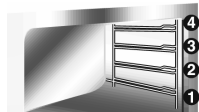

Roof liner: remove it to simplify cleaning inside the oven.

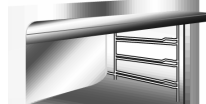

Shelf: useful to support pans containing the food for cooking.



Tray grid: for placing on top of a tray for cooking foods which may drip.

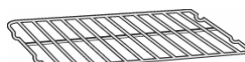

Oven tray: useful for collecting fat from foods placed on the grid above.

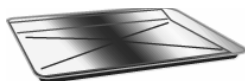

Tongs: The tongs can be used either for removing hot trays or for taking out the pizza plate as described in paragraph 13.6 Cleaning the pizza plate.



Rotisserie frame: supports the rotisserie rod (see page 52 for instructions for use).



Rotisserie rod: useful for cooking chicken and all foods which require uniform cooking over their entire surface. (see page 52 for instructions for use).

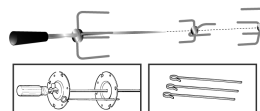

Pizza plate: specially designed for cooking pizza and related foods. For use as described in point "8. USING THE PIZZA FUNCTION"

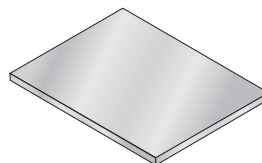



Instructions for the User

GB-IE

Pizza shovel: a convenient way of putting the pizza on the special plate in the oven.

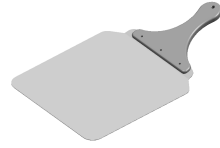

Toasting racks: the appliance comes complete with two toast racks. The racks must be placed inside the slots in the toaster. Each of these racks can take up to 2 toasted sandwiches.

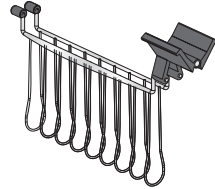

Bottom cover plate: for use instead of the pizza plate. Use so that the pizza plate does not get dirty during normal cooking operations.

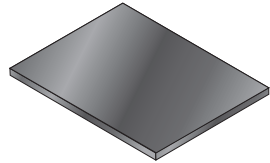

Optional accessories

Original accessories can be ordered through our Authorised Service Centres. The following optional accessories are also available for order.

Double pizza shovel: a convenient way of putting the pizza on the special plate in the oven. This two-handle pizza shovel makes it easier to cook larger-size pizzas.

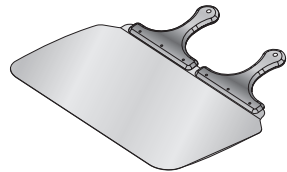



12. COOKING TABLES



*The oven must be preheated before all cooking operations.
Do not place the foods inside the oven until it has reached the set temperature. The oven pilot light flashes to indicate this.*

Cooking times, for meat in particular, vary depending on the food's thickness and quality and personal preference. All times are calculated with the oven preheated.

CONVENTIONAL COOKING



	RUNNER POSITION FROM THE BOTTOM	TEMPERATURE °C.	TIME IN MINUTES
PASTA			
LASAGNE	1	220 - 230	50 - 60
PASTA BAKES	1	220 - 230	40
MEAT			
ROAST VEAL	2	190 - 200	80 - 90
LOIN OF PORK	2	190 - 200	80 - 90
SHOULDER OF PORK	2	190 - 200	100 - 110
RABBIT	2	190 - 200	70 - 80
TURKEY BREAST	2	190 - 200	160 - 180
ROAST NECK OF PORK	2	190 - 200	190 - 210
FISH	1 - 2	160 - 170	Depending on size
PIZZA	1 - 2	250	20 - 25
BREAD	1 - 2	200 - 210	40
MUFFINS	2	190 - 200	20 - 25
CONFECTIONERY			
SPONGE CAKE	1 - 2	160 - 170	55 - 60
FRUIT TART	1 - 2	160 - 170	30 - 40
PASTRY	1 - 2	160 - 170	20 - 25
CROISSANTS	1 - 2	160 - 180	25 - 30
JAM TARTS	1 - 2	160 - 170	30 - 35
RICE CAKE	1 - 2	160 - 170	60
ANGEL CAKE	1 - 2	160 - 170	60
ECLAIR	1 - 2	160 - 170	40 - 45
LIGHT SPONGE CAKE	1 - 2	160 - 170	40 - 45



Instructions for the User



HOT AIR COOKING



	RUNNER POSITION FROM THE BOTTOM	TEMPERATURE °C.	TIME IN MINUTES
PASTA			
LASAGNE	2	210 - 230	45 - 50
PASTA BAKES	2	210 - 230	25 - 30
MEAT			
ROAST VEAL	2	180 - 190	70 - 80
LOIN OF PORK	2	180 - 190	70 - 80
SHOULDER OF PORK	2	180 - 190	90 - 100
RABBIT	2	180 - 190	70 - 80
TURKEY BREAST	2	180 - 190	110 - 120
ROAST CHICKEN	2	180 - 190	60 - 70
FISH			
SALMON TROUT	2	150 - 160	35 - 40
PIZZA			
	1 - 2	250 - 280	5 - 10
BREAD			
	1	190 - 200	25 - 30
MUFFINS			
	1 - 2	180 - 190	15 - 20
CONFECTIONERY			
SPONGE CAKE	2	160	50 - 60
LARGE JAM TART	2	160	25 - 30
PASTRY	2	170	20 - 25
CROISSANTS	2	160 - 170	20 - 25
JAM TARTS	2	160	20 - 25
ANGEL CAKE	2	160	60



The oven door must always be closed while the grill or rotisserie is in use.

The maximum heating time in these cooking modes must not exceed 60 minutes and the maximum permitted temperature setting is 200°C.

GRILLING



	RUNNER POSITION FROM THE BOTTOM	TIME IN MINUTES	
		1ST SIDE	2ND SIDE
PORK CUTLET	4	7 - 9	5 - 7
PORK FILLET	3	9 - 11	5 - 9
FILLET STEAK	3	9 - 11	9 - 11
SLICED LIVER	4	2 - 3	2 - 3
VEAL ESCALOPES	4	7 - 9	5 - 7
HALF CHICKEN	3	9 - 14	9 - 11
SAUSAGE	3	7 - 9	5 - 6
MEATBALLS	3	7 - 9	5 - 6
FISH FILLET	3	5 - 6	3 - 4
TOASTED SANDWICHES	3	2 - 4	2 - 3



ROTISSERIE COOKING



Prepare the rotisserie rod with the food, tightening the screws **A** of the prongs. Fit the frame **B** into the holes provided in the sides of the tray. Remove the handle **D** and position the rotisserie rod so that the pulley **E** is still in the guides on the frame **B**. Push the frame **B** fully in until the tip of the rotisserie rod enters the hole **C** on the rear wall of the oven. If necessary, pour a little water into the frame support tray to prevent smoking.

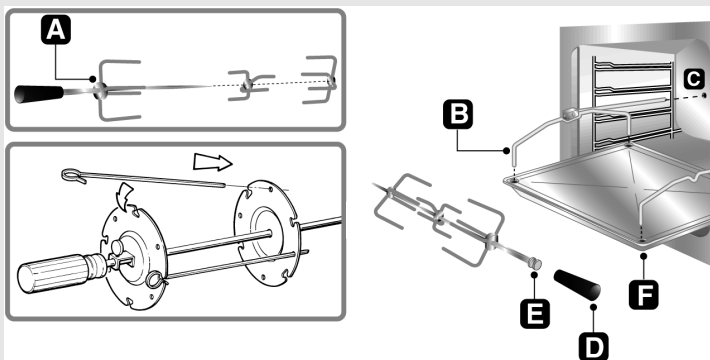



Instructions for the User

GB-IE

13. CLEANING AND MAINTENANCE



Before carrying out any operations, disconnect the appliance from the electricity supply.



Never use a jet of steam for cleaning the inside of the oven or toaster.

13.1 Cleaning stainless steel



To keep stainless steel in good condition, it must be cleaned regularly, after each use of the oven, after allowing it to cool.

13.2 Routine daily cleaning

When cleaning and caring for stainless steel surfaces, always use **only** specific products which do not contain abrasives or chlorine-based acids.

Instructions for use: pour the product onto a damp cloth and wipe over the surface, then rinse thoroughly and dry with a soft cloth or chamois leather.

13.3 Food stains or spills

Never use metal scouring pads or sharp scrapers; they will damage surfaces.

Use ordinary non-abrasive products with the aid of wooden or plastic utensils if necessary. Rinse thoroughly and dry with a soft cloth or chamois leather.

Do not allow spills of foods with high sugar content (e.g. jam) to dry inside the oven. If they dry for too long, they might damage the enamel coating of the inside of the oven.





13.4 Cleaning the oven



To keep the oven in good condition, it must be cleaned regularly, after allowing it to cool down.

Remove all removable parts.



Clean the oven shelves with hot water and non-abrasive detergents, rinse and dry. For easier cleaning, the door can be removed (see point “14.2 Removing the door”)

The bottom of the oven can also be cleaned.

Remove the pizza plate as described in point “13.6 Cleaning the pizza plate”; now lift the end of the heating element next to the door of the oven and clean the bottom. The heating element must only be lifted a few centimetres as otherwise damage to the structure may result.



When the operations are complete, damp parts should be dried thoroughly.



The oven should be operated at the maximum heat setting for 15/20 minutes after use of specific products, to burn off the residues left inside the oven.



Instructions for the User

GB-IE

13.5 Cleaning the oven with self-cleaning liners

The oven is fitted with enamelled liners that are continuously self-cleaning. These liners simplify cleaning of the oven and ensure it continues to perform well over time.

13.5.1 Using the self-cleaning liners

To keep the inside of the oven clean and free from food residues and unpleasant smells, it should periodically be operated empty at a temperature of at least 200° C for a time varying between 30 and 60 minutes. This allows the self-cleaning liners to oxidise any deposits present, which can then be wiped away with a damp sponge once the oven has cooled.

13.5.2 Maintenance of self-cleaning liners

The liners should not be cleaned using abrasive creams and ordinary cleaners. Simply wipe with a damp sponge to avoid damaging the special enamel coating.

13.5.3 Removing the self-cleaning liners

Remove all accessories from the inside of the oven and proceed as follows:

- 1 Remove the side runners (1);
- 2 Extract the side liners "C" and "D" (2);
- 3 Extract the back liner "A" after undoing the threaded ring-nuts "B" (fig. 2);
- 4 Replace the liners in their original positions.

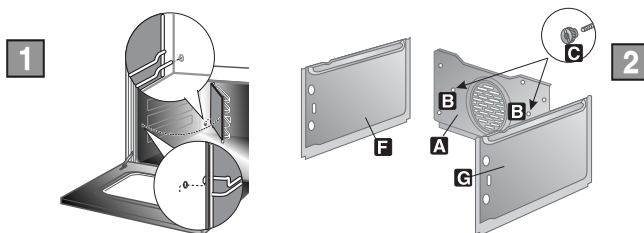



13.6 Cleaning the pizza plate

To clean the pizza plate, proceed as follows with the oven cold:

- 1 Open the oven door and use the supplied tongs (see figure) to lift the pizza plate.
- 2 Now remove it from the oven to clean it.

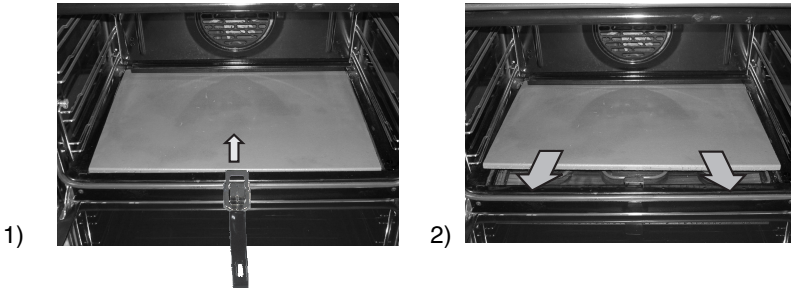

When returning the pizza plate to its place, take great care not to knock it accidentally.

Use the removal lever for assistance if necessary.

The pizza plate must be washed separately;

- Before cleaning, remove any dirt burnt onto the stone with the aid of a metal spatula or a scraper of the kind used for cleaning ceramic hobs;
- For best results, the stone must still be warm; otherwise, wash it in hot water;
- Use metal mesh or non-abrasive scouring pads, dipped in lemon or vinegar;
- Never use detergents;
- Never wash in the dishwasher;
- Never leave the stone to soak;
- The damp stone must not be used for a least 8 hours after the end of the cleaning procedures;
- Over time, slight cracks may appear on the surface of the stone. This is due to the normal expansion of the stone's finishing glazes at high temperatures.

13.7 Cleaning the toaster

To clean the toaster, first open it by pressing on the zone marked "PUSH". Once open, it can be cleaned by simply removing the crumb tray (the tray is inside the toaster rack slot structure). Pull the tray out to the left and empty out the crumbs; taken care when putting it back in place.

Use a damp cloth to clean the outside of the rack slot structure.



Instructions for the User

GB-IE

13.8 Cleaning the door glazing

The glass in the door should always be kept thoroughly clean. Use absorbent kitchen roll; remove stubborn dirt with a damp sponge and ordinary detergent.



Do not use abrasive or corrosive cleaners for cleaning the door glazing. (e.g. powder products, oven-cleaner sprays, stain removers and metal scouring pads).

Do not use rough or abrasive materials or sharp metal scrapers to clean the oven's glass doors since they may scratch the surface and cause the glass to shatter.



14. EXTRAORDINARY MAINTENANCE

Occasionally, the oven will require minor servicing procedures or the replacement of parts subject to wear and tear, such as gaskets, light bulbs, etc. The specific operations for each procedure of this kind are provided below.



Before carrying out any operation involving access to live parts, disconnect the appliance from the electricity supply.

14.1 Changing the light bulbs

Remove the protective cover **A** by unscrewing it anti-clockwise and replace the bulb **B** with another of the same type (25 W). Replace the protective cover **A**.

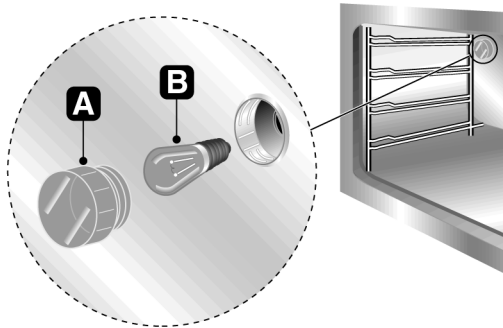

Use only light bulbs approved for ovens (T 300°C).



Instructions for the User

GB-IE

14.2 Removing the door

14.2.1 With type 1 mobile levers

With the door completely open, lift the levers **A** of the two hinges until they touch the hinges **B** and take hold of the two sides of the door with both hands close to the hinges themselves.

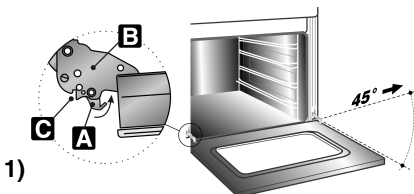

Raise the door to an angle of about 45° and remove it. If the hinges have not locked, repeat the operation, raising the levers **A** and keeping the door slightly raised. To reassemble, fit the hinges **B** into their grooves, then lower the door into place, ensuring that it remains fitted into the grooves **C**, then lower the levers **A**.

14.2.2 Removing doors with pins

Open the door completely and insert the pins (supplied) into the holes from the inside. Close the door to an angle of about 45° and lift it off. To reassemble, fit the hinges into their grooves, then lower the door into place and extract the pins.

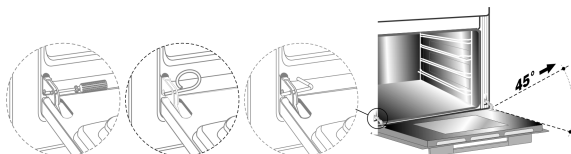

14.3 Removing the gasket

To allow thorough cleaning of the oven, the door gasket can be removed.

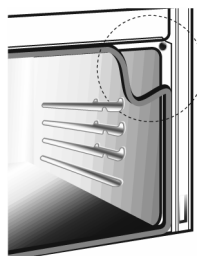

Use absorbent kitchen roll; remove stubborn dirt with a damp sponge and ordinary detergent.



14.4 Removing the door glazing



Caution: before removing the glass, make sure that at least one of the door's hinges has been locked in open position as described in points "14.2 Removing the door". This operation might have to be repeated during the glass removal process if the door is accidentally freed.



Caution: when cleaning is complete, remember to release the hinges before closing the door.

The diagram below illustrates the procedure for removing the door glazing.

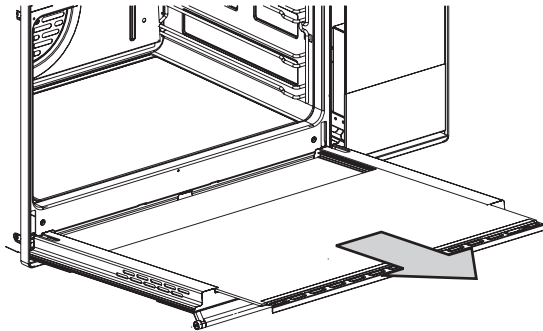



Instructions for the Installer

GB-IE

15. INSTALLING THE APPLIANCE

15.1 Electrical connection



The nameplate with the technical data, serial number and mark is in a visible position on the oven door frame.

The nameplate must never be removed.

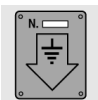

The appliance must be connected to earth in compliance with electrical system safety regulations.



If a permanent connection is used, the appliance's power supply line must be fitted with an omnipolar breaking device with contact gap of at least **3 mm**, located in an easily accessible position close to the appliance itself.



If a socket and plug connection is used, check that they are of the same type. Do not use reducers, adapters or junctions since they may cause overheating or burns.



Operation at 220-240 V~: use a type H05RR-F (3 x 1.5 mm²) or type H05V2V2-F (3 x 1.5 mm²) three-wire cable.



The earth wire (yellow-green) must be at least 20 mm longer than the other wires at the end for connection to the appliance.

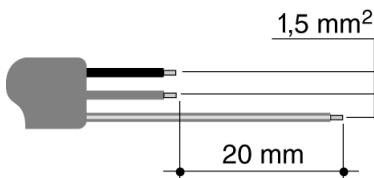

If the power supply lead has to be replaced, remove the rear casing by undoing the screws. The power lead gauge must be at least 1.5 mm² (3 x 1.5 cable) and it must withstand temperatures up to 90°C (H05V2V2-F or H05RR-F). Make sure that the cables follow the best possible route and use band clamps to fix them at the side of the cabinet, to avoid any contact with the oven.



15.2 Positioning the oven

The appliance is designed for building-in to cabinets made from any heat-resistant material. Comply with the dimensions shown in figures 1, 2, and 3. When installing under worktops, comply with the dimensions shown in figure 1-3. When installing under worktops incorporating combined hobs, a gap of at least 110 mm must be left from any side wall, as shown in figure 1.

When installing in tall units, comply with the dimensions shown in figure 1-2, bearing in mind that the top/rear of the unit must have an opening 80-90 mm deep. Screw the 2 screws **A** into the inside of the frame (fig. 1). For installation under counter-top hobs, make sure that the rear/bottom of the unit has an opening similar to that shown in figure 1 (ref. **B**). See the instructions supplied with the hob for the relative positioning and fixing procedures.

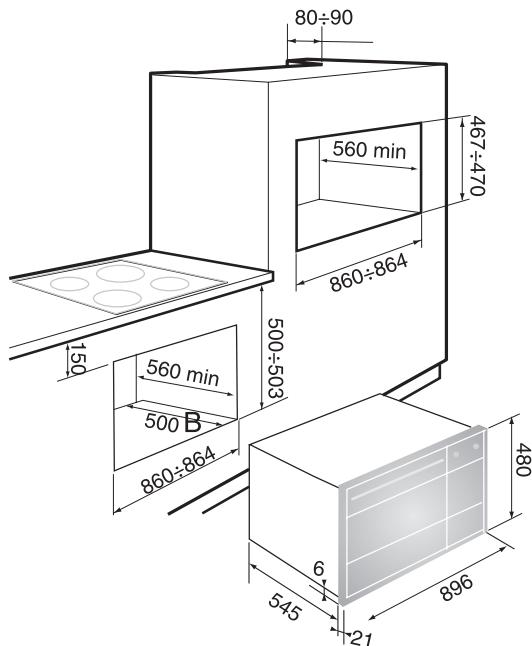

Never use the door for leverage when inserting the oven in the cabinet. Never apply excessive pressure to the open door.

