

- 1. PRECAUTIONS FOR USE 33
- 2. DISPOSAL INSTRUCTIONS - OUR ENVIRONMENT POLICY 34
- 3. SAFETY PRECAUTIONS 35
- 4. GET TO KNOW YOUR OVEN 36
- 5. BEFORE INSTALLATION 36
- 6. DESCRIPTION OF FRONT PANEL CONTROLS 37
- 7. USING THE OVEN 39
- 8. USING THE PIZZA FUNCTION (ON SOME MODELS ONLY) 46
- 9. ACCESSORIES AVAILABLE 48
- 10. RECOMMENDED COOKING TABLES 49
- 11. CLEANING AND MAINTENANCE 51
- 12. EXTRAORDINARY MAINTENANCE 55
- 13. INSTALLING THE APPLIANCE 58



INSTRUCTIONS FOR THE USER: *these provide recommendations for use, a description of the controls and the correct procedures for cleaning and maintaining the appliance*



INSTRUCTIONS FOR THE INSTALLER: *these are intended for the qualified engineer who is to install, commission and test the appliance*

1. PRECAUTIONS FOR USE



THIS MANUAL IS AN INTEGRAL PART OF THE APPLIANCE. TAKE GOOD CARE OF IT AND KEEP IT TO HAND THROUGHOUT THE OVEN'S LIFE CYCLE. WE URGE YOU TO READ THIS MANUAL AND ALL THE INFORMATION IT CONTAINS CAREFULLY BEFORE USING THE APPLIANCE. INSTALLATION MUST BE CARRIED OUT BY QUALIFIED STAFF IN COMPLIANCE WITH THE RELEVANT REGULATIONS. THIS APPLIANCE IS INTENDED FOR HOUSEHOLD USE AND COMPLIES WITH THE EEC DIRECTIVES CURRENTLY IN FORCE. THE APPLIANCE IS BUILT TO PROVIDE THE FOLLOWING FUNCTION: COOKING AND HEATING FOODS; ALL OTHER USES ARE TO BE CONSIDERED IMPROPER. THE MANUFACTURER DECLINES ALL LIABILITY FOR USES OTHER THAN THOSE STATED ABOVE.



NEVER USE THIS APPLIANCE FOR HEATING ROOMS.



NEVER LEAVE PACKAGING RESIDUES UNATTENDED IN THE HOME. SEPARATE THE VARIOUS PACKAGING MATERIALS BY TYPE AND CONSIGN THEM TO THE NEAREST SEPARATE DISPOSAL CENTRE.



THIS APPLIANCE IS TAGGED UNDER EUROPEAN DIRECTIVE 2002/96/EC ON WASTE ELECTRICAL AND ELECTRONIC EQUIPMENT (WEEE). THIS DIRECTIVE CONTAINS THE REGULATIONS GOVERNING THE COLLECTION AND RECYCLING OF DECOMMISSIONED APPLIANCES THROUGHOUT THE EUROPEAN UNION.



NEVER OBSTRUCT THE OPENINGS AND SLITS PROVIDED FOR VENTILATION AND HEAT DISPERSAL.



THE NAMEPLATE WITH THE TECHNICAL DATA, SERIAL NUMBER AND MARK IS IN A VISIBLE POSITION ON THE OVEN DOOR FRAME. THE NAMEPLATE MUST NEVER BE REMOVED.



NEVER USE METAL SCOURING PADS OR SHARP SCRAPERS; THEY WILL DAMAGE SURFACES.

USE ORDINARY NON-ABRASIVE PRODUCTS WITH THE AID OF WOODEN OR PLASTIC UTENSILS IF NECESSARY. RINSE THOROUGHLY AND DRY WITH A SOFT CLOTH OR CHAMOIS LEATHER.

DO NOT ALLOW SPILLS OF FOODS WITH HIGH SUGAR CONTENT (E.G. JAM) TO DRY INSIDE THE OVEN. IF THEY DRY FOR TOO LONG, THEY MIGHT DAMAGE THE ENAMEL COATING OF THE INSIDE OF THE OVEN.



Disposal instructions



2. DISPOSAL INSTRUCTIONS - OUR ENVIRONMENT POLICY

Our products are only packaged using non-pollutant, environment-friendly, recyclable materials. We urge you to cooperate by disposing of the packaging properly. Contact your local dealer or the competent local organisations for the addresses of collection, recycling and disposal facilities.

Never leave all or part of the packaging lying around. Packaging parts, and especially plastic bags, may represent a suffocation hazard for children.

Your old appliance must also be disposed of properly.

Important: deliver the appliance to your local organisation authorised to collect scrapped appliances. Proper disposal allows the intelligent recovery of valuable materials.

Before scrapping your appliance it is important to remove doors and leave shelves in position as for use, to ensure that children cannot accidentally become trapped inside the oven during play. Also, cut the power supply lead and remove it and the plug.

3. SAFETY PRECAUTIONS



REFER TO THE INSTALLATION INSTRUCTIONS FOR THE SAFETY REGULATIONS FOR ELECTRIC OR GAS APPLIANCES AND VENTILATION FUNCTIONS.

IN YOUR INTEREST AND TO ENSURE YOUR SAFETY, BY LAW ALL ELECTRIC APPLIANCES MUST ONLY BE INSTALLED AND SERVICED BY QUALIFIED STAFF, IN ACCORDANCE WITH THE RELEVANT REGULATIONS.

OUR APPROVED INSTALLATION ENGINEERS GUARANTEE YOU A JOB WELL DONE.

GAS OR ELECTRIC APPLIANCES MUST ALWAYS BE DISCONNECTED BY SUITABLY SKILLED PEOPLE.



THE PLUG TO BE CONNECTED TO THE POWER SUPPLY LEAD AND THE RELATIVE SOCKET MUST BE OF THE SAME TYPE AND COMPLY WITH THE RELEVANT REGULATIONS.

THE POWER SUPPLY SOCKET MUST BE ACCESSIBLE EVEN AFTER THE APPLIANCE HAS BEEN BUILT-IN.

NEVER DISCONNECT THE PLUG BY PULLING ON THE POWER SUPPLY LEAD.



THE APPLIANCE MUST BE CONNECTED TO EARTH IN COMPLIANCE WITH ELECTRICAL SYSTEM SAFETY REGULATIONS.



IMMEDIATELY AFTER INSTALLATION, CARRY OUT A QUICK TEST ON THE APPLIANCE FOLLOWING THE INSTRUCTIONS PROVIDED LATER IN THIS MANUAL. IF THE APPLIANCE FAILS TO OPERATE, DISCONNECT IT FROM THE ELECTRICAL MAINS AND CONTACT YOUR NEAREST SERVICE CENTRE. NEVER ATTEMPT TO REPAIR THE APPLIANCE.



NEVER PLACE INFLAMMABLE OBJECTS IN THE OVEN: IF IT SHOULD ACCIDENTALLY BE SWITCHED ON, THIS MIGHT CAUSE A FIRE.



THE APPLIANCE BECOMES VERY HOT DURING USE. TAKE CARE NOT TO TOUCH THE HEATING ELEMENTS INSIDE THE OVEN.



THE USE OF THIS APPLIANCE IS NOT PERMITTED TO PEOPLE (INCLUDING CHILDREN) OF REDUCED PHYSICAL AND MENTAL ABILITY, OR LACKING IN EXPERIENCE IN THE USE OF ELECTRICAL APPLIANCES, UNLESS THEY ARE SUPERVISED OR INSTRUCTED BY ADULTS OR PEOPLE RESPONSIBLE FOR THEIR SAFETY.



BEFORE THE APPLIANCE IS PUT INTO OPERATION, ALL THE PROTECTIVE FILMS APPLIED ON THE OUTSIDE MUST BE REMOVED.



The manufacturer declines all responsibility for injury or damage caused by failure to comply with the above regulations or deriving from tampering with even just one part of the appliance and the use of non-original spare parts.

Instructions for the User



4. GET TO KNOW YOUR OVEN

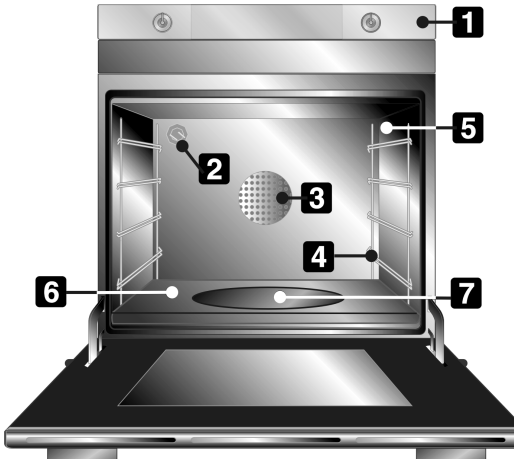

- 1** CONTROL PANEL
- 2** OVEN LIGHT
- 3** OVEN FAN
- 4** SHELF AND TRAY RUNNERS
- 5** TEMPERATURE SENSOR
- 6** BOTTOM PLATE (ON SOME MODELS ONLY)
- 7** PIZZA PLATE / COVER RECESS (ON SOME MODELS ONLY)

5. BEFORE INSTALLATION



Never leave packaging residues unattended in the home. Separate waste packaging materials by type and consign them to the nearest separate disposal centre.



The inside of the appliance should be cleaned to remove all manufacturing residues. For further information about cleaning, see point "11. CLEANING AND MAINTENANCE".



Instructions for the User

6. DESCRIPTION OF FRONT PANEL CONTROLS

All the appliance's control and monitoring devices are placed together on the front panel. The table below provides the key to the symbols used.

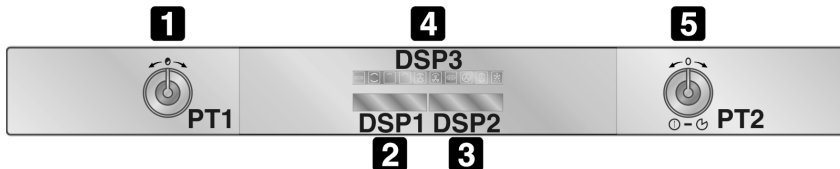

1
PT1

THERMOSTAT-TIMER KNOB

This knob allows you to set the time, select the cooking temperature and duration and program the cooking start and end times. **From now on, for convenience it will be referred to as PT1.** For instructions on how to use it correctly, see point “7.3 First use” and “7.5 Programmed cooking procedures”.

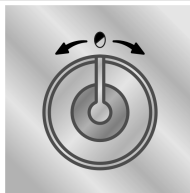



2
DSP1

CURRENT TIME/PROGRAMMED COOKING OPERATION DISPLAY

This display shows the current time or the cooking duration. **From now on, for convenience it will be referred to as DSP1.**

3
DSP2

TEMPERATURE DISPLAY

This display shows the temperature set for the function required, or the temperature set by the user. Also visible are the function cutout light  (see point “7.6.1 Child safety lock-out function”) and the preheating level  (see point “7.4 Selecting the function”). **From now on, for convenience it will be referred to as DSP2.**

4
DSP3

FUNCTION DISPLAY

This display shows (illuminated) all the cooking functions available for selection. For instructions on how to select a cooking function, see point “7.2 Operating modes”. **From now on, for convenience it will be referred to as DSP3.**

Instructions for the User



5

FUNCTION-SWITCH ON KNOB

PT2

This knob allows access to the oven's three operating modes, and is also used to select a cooking function (see point "7.2 Operating modes").

From now on, for convenience it will be referred to as PT2.

The table below provides a short description of the functions available.



ECO

GRILL ELEMENT IN OPERATION ALTERNATING WITH BOTTOM HEATING ELEMENT + FAN



GRILL ELEMENT + FAN



TOP + BOTTOM HEATING ELEMENTS



BOTTOM HEATING ELEMENT + FAN



GRILL ELEMENT



PIZZA FUNCTION (ON SOME MODELS ONLY)



GRILL ELEMENT + TOP HEATING ELEMENT



ROUND HEATING ELEMENT



TOP + BOTTOM HEATING ELEMENTS+FAN



FAN HEATING ELEMENT + TOP + BOTTOM HEATING ELEMENTS



DEFROSTING AND PROVING



Instructions for the User

GB-IE

7. USING THE OVEN

7.1 Precautions and General Advice



All cooking operations must be carried out with the door closed

When the oven and grill are used for the first time, they should be heated to the maximum temperature for long enough to burn off any oily residues left by the manufacturing process, which might contaminate foods with unpleasant smells.



During cooking, do not cover the bottom of the oven with aluminium or tin foil, and do not place pans or trays on it; this may damage the enamel coating. If you wish to use greaseproof paper, position it so that it does not interfere with the hot air circulation inside the oven.



Oven accessories which may come into contact with foods are made from materials compliant with directive 89/109/EEC of 21/12/88 and national relevant regulations.



To avoid unpleasant contact with any steam inside the oven, open the door in two stages: hold it half-open (about 5 cm) for 4-5 seconds, then open it completely. If you have to carry out any procedures on foods, leave the door open for as short a time as possible to prevent a drop in the oven temperature which will impair the cooking results.



To prevent excessive amounts of condensation from forming on the internal glass, food should not be left inside the oven for too long after cooking.

7.2 Operating modes

This product is programmed to provide 3 operating settings, which can be modified by pressing PT2.

Standby setting: activated as soon as the current time has been confirmed, with DSP1 on and showing the current time.

ON setting: from the standby setting, press PT2 once. All the displays and knobs light up.

OFF setting: from the ON setting, press PT2 once.

Only the ☺ symbol on DSP1 remains on.

The heating system is not activated immediately in any of these functions, in order to improve operator safety.



7.3 First use

At first use, or after a power failure, the oven's left hand-display, DSP1, will show a flashing **00:00** symbol. To start any cooking operation, the current time must be set.

7.3.1 Setting the current time

To set the current time, turn PT1 to the right and left to increase or decrease the hours. Press it once to move on to setting the minutes. Turn it the right and left to increase or decrease the minutes and press it to set the current time. The  symbol will appear on the display, which will stop flashing.



7.3.2 Changing the current time

It might become necessary to change the current time, for example at the switch from summer to winter time. To do this, starting from the standby setting (see point "7.2 Operating modes") keep PT1 pressed until the figures on DSP1 flash. Now repeat the operations described in point "7.3.1 Setting the current time".

7.4 Selecting the function

In the ON state only, a cooking function can be selected by simply turning PT2 to the right or left. The function selected will change colour to red on DSP3. The preset cooking temperature will be displayed on DSP2.

7.4.1 Cooking with preset temperature

After selection of the function required, the oven will start the cooking procedure at the preset temperature. Cooking itself is preceded by a preheating stage, which allows the oven to heat to the cooking temperature more quickly. The ° symbol flashes on DSP2 to indicate that this stage is in progress. The  symbols will light up one at a time, from the bottom up, indicating the rise in the temperature inside the oven. When the preheating stage is over, the ° and  symbols will remain constantly on to indicate that the food can be placed inside the oven.

7.4.2 Changing the preset temperature

The temperature preset for each function can be changed to suit the user's requirements.

At any time while cooking is in progress, turn PT1 in either direction to increase or decrease the cooking temperature by 5 degrees at a time. PT1 can also be held in the left or right position to increase or decrease the setting more quickly.



Instructions for the User

GB-IE

7.5 Programmed cooking procedures

7.5.1 Cooking with minute minder

From ON status (see point “7.2 Operating modes”), press PT1 once. The display will show the **00:00** figures (constantly on) and the **⏰** symbol (flashing). Turn PT1 to set the minutes of cooking (from 00:01 to 23:59). A few seconds after the required duration is set, the **⏰** symbol will stop flashing, and the countdown will start from that moment. Now select the cooking function required and wait for the buzzer to sound, indicating that the cooking time is over.

When cooking is over, to stop the buzzer and halt cooking, press PT2 once to switch the oven to OFF status.



The minute minder also works with no function set.



Warning: the minute minder does not stop the cooking process. It only warns the user that the preset number of minutes have passed.

To switch the oven off, press PT2.

Modifying the data set

Once the countdown has started, its duration can be changed while cooking is in progress.

When the **⏰** symbol is steady and cooking is in progress, press PT1 once. The **⏰** symbol starts flashing and PT1 can be turned to change the set duration. A few seconds after the last change, the **⏰** symbol will stop flashing, and the countdown will restart from the new value.

To change the preset temperature, wait for the **⏰** symbol to become steady and turn PT1 to the right or left to increase or decrease the cooking temperature.

7.5.2 Semiautomatic cooking



Semiautomatic cooking is the function which allows a cooking operation to be started and then ended after a specific length of time set by the user.

Select a cooking function (see point “7.4 Selecting the function”) and press PT1 twice. The display will show the **00:00** figures and the **⏰** symbol (flashing).

Turn PT1 to the right or left to set the minutes of cooking (from 00:01 to 23:59). A few seconds after the required duration is set, the **⏰** symbol will stop flashing, and semiautomatic cooking will start from that moment. At the end, the word STOP will appear on DSP1, cooking will stop and a buzzer will sound; press PT1 to deactivate it.



Instructions for the User



Once PT1 has been pressed, the oven will return to normal operation. PT2 has to be pressed to switch the oven off completely.

Modifying the data set

Once semiautomatic cooking has started, its duration can be changed.



When the  symbol is steady and cooking is in progress, press PT1 once. The  symbol starts flashing and PT1 can be turned to change the set duration. A few seconds after the last change, the  symbol will stop flashing, and semiautomatic cooking will restart from the new value.

To change the preset temperature, wait for the  symbol to become steady and turn PT1 to the right or left to increase or decrease the cooking temperature.

7.5.3 Automatic cooking



Automatic cooking is the function which allows a cooking operation to be started at a set time and then ended after a specific length of time set by the user.

Select a cooking function, set the cooking temperature required or leave the preset temperature (see point "7.4 Selecting the function") and press PT1 twice. The display will show the  figures and the  symbol (flashing).

Turn PT1 to the right or left to set the minutes of cooking (from 00:01 to 23:59).





For reasons of safety, when setting automatic cooking the user must first program a cooking duration and then set the cooking start time. It is not possible to set the cooking start time only, without setting the cooking duration.

After setting the duration, press PT1 once.

The  symbol and the current time will appear on the display.

Turning PT1 to the right increases the time, allowing the **cooking start time required to be set**.

A few seconds after the required duration is set, the  and  symbols will stop flashing, and the oven will start to wait for the starting time set. At the end, the word STOP will appear on DSP1, cooking will stop and a buzzer will sound; press PT1 to deactivate it.



Once PT1 has been pressed, the oven will return to normal operation. PT2 has to be pressed to switch the oven off completely.



Instructions for the User

GB-IE

Modifying the data set

Once automatic cooking has started, its duration can be changed.

When the and symbols are steady and cooking is in progress, or the oven is in standby status waiting for cooking to start, press PT1 once. The symbol starts flashing and PT1 can be turned to change the set duration.

Press PT1 again; the symbol goes out, the symbol will start to flash, and the cooking start time will be displayed on DSP1. The cooking start time can be increased or decreased by turning PT1.

A few seconds after the last change, the e symbols will appear (in steady mode) on DSP1 and automatic cooking will restart with the new settings.



Once cooking has been programmed, before it starts all the lamps on the control panel will be on, except for DSP2 which will illuminate when cooking has started, showing the set temperature.

7.6 Secondary menu

This appliance also has a concealed "secondary menu" allowing the user to:

- 1 Activate or deactivate the child safety device ();
- 2 Activate or deactivate the Show Room function (which disables all the heating elements so that only the control panel works);
- 3 Activate or deactivate the function which limits the maximum power absorption to 2300 W;

7.6.1 Child safety lock-out function

With the oven in OFF status (see point "7.2 Operating modes") keep PT1 pressed until the message OFF SHO appears on DSP1. Now press PT1 until the message "OFF BLOC" appears on DSP1.

Turn PT1 to the right or left to activate (ON BLOC) or deactivate (OFF BLOC) this function, which locks out all the functions and knobs after 3 minutes of operation without any command from the user (when this system is active, the appears on DSP2).

After setting the parameter required, press PT2 to return the oven to the initial standby status.

To exit the lockout status temporarily to modify a cooking program or select a different function, keep PT1 pressed until the disappears from DSP2. The required changes can now be made, and 3 minutes after the last setting is made the lockout will come into operation again.

To deactivate the lockout permanently, access the secondary menu and switch the function off as described in this section.



7.6.2 Show Room Function

With the oven in OFF status (see point “7.2 Operating modes”) keep PT1 pressed until the message OFF SHO appears on DSP1. This means that the SHOW ROOM function (which disables all the heating elements so that only the control panel works) is not active.

Turn PT1 to the right or left to activate (ON SHO) or deactivate (OFF SHO) this function. To use the oven normally, set OFF SHO.

After setting the parameter required, press PT2 to return the oven to the initial standby status.

7.6.3 Power selection function

With the oven in OFF status (see point “7.2 Operating modes”) keep PT1 pressed until the message OFF SHO appears on DSP1. Now press PT1 once again and the message “OFF 2300” will appear on DPS1.

Turn PT1 to the right or left to activate (ON 2300) or deactivate (OFF 2300) this function, which limits the oven's maximum power absorption, in any function, to 2300 W.

After setting the parameter required, press PT2 to return the oven to the initial standby status.



Instructions for the User

GB-IE

7.7 *Cooling fan system*

The appliance is equipped with a cooling system which comes into operation as soon as a cooking function starts.

Operation of the fans generates a normal air flow which comes out above and underneath the door and may continue for a short time even after the oven is switched off.

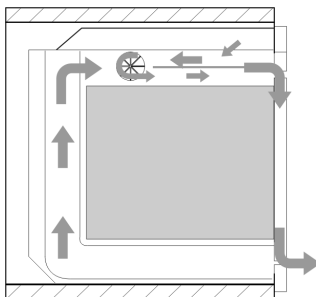

7.8 *Inside light*

The oven light comes on:

- when the oven door is opened in standby status (point "7.2 Operating modes") or
- when the function knob is turned to any function.



8. USING THE PIZZA FUNCTION (ON SOME MODELS ONLY)

This appliance is equipped with a function specially developed for cooking pizza. This function is identified by the  symbol on the oven functions knob. To cook a pizza, proceed as described below.

With the oven cold, remove the circular cover from the bottom of the oven (fig. 1) and fit the pizza plate in its place (Fig. 2).

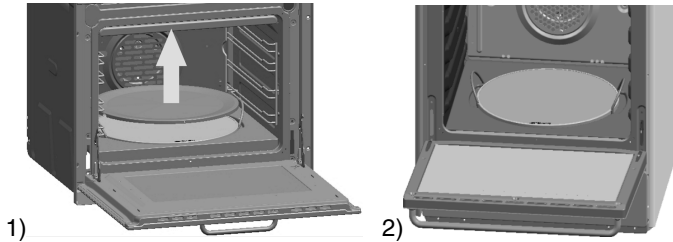

Set the oven functions knob on the  symbol and the thermostat knob on **280°C**. Preheat with these settings until the thermostat light goes out, then place the pizza on the special plate. It does not normally take more than 3-4 minutes to cook a pizza to perfection, although this time may vary depending on the dough used or individual taste.

8.1 Precautions for using the pizza plate

- Never use the pizza plate except as described above (for example, never use it on gas or ceramic hobs, or on ovens not designed to take this accessory).
- The pizza plate may be left in place while conventional cooking operations are in progress. Simply place the cover over it, taking care to fit it securely.
- Never use any oven function if the pizza plate or cover is not in position.
- The appliance becomes very hot during use. Oven gloves should always be worn.
- If you like oil on your pizza, it is best to add it after removal from the oven since oil stains on the pizza plate are unsightly and may reduce its efficiency.



Instructions for the User

GB-IE

8.2 To save energy

The pizza stone acts as a heat reservoir. This allows energy consumption to be reduced, especially in cooking operations requiring pre-heating or medium-long times. In these cases, simply turn the thermostat to zero 10-12 minutes before the end of the cooking time. The heat gradually emitted by the refractory stone will ensure that the cooking temperature is maintained.



9. ACCESSORIES AVAILABLE

The oven is fitted with **4 runners** for placing trays and shelves at different heights.

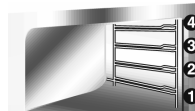

Shelf: useful to support pans containing the food for cooking.

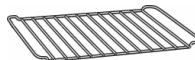

Tray grid: for placing on top of a tray for cooking foods which may drip.

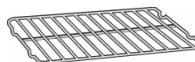

Oven tray: useful for collecting fat from foods placed on the grid above.



Baking tray: useful for cooking cakes, pizza and confectionery.



Pizza plate (on some models only) specially designed for cooking pizza. For use as described in point "8. USING THE PIZZA FUNCTION (on some models only)"



Roof liner: remove it to simplify cleaning inside the oven.

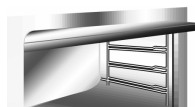

Chromium-plated gripper: useful for removing hot shelves and trays.



Not all accessories are provided on some models.

Optional accessories

Original accessories can be ordered through our Authorised Service Centres.



Instructions for the User

GB-IE

10. RECOMMENDED COOKING TABLES



The oven must be preheated before all cooking operations.

Do not place the foods inside the oven until the degrees Centigrade symbol on the display stops flashing and the beep has sounded to confirm that the set temperature has been reached.

Cooking times, for meat in particular, vary depending on the food's thickness and quality and personal preference. All times are calculated with the oven preheated.

CONVENTIONAL COOKING



	RUNNER POSITION FROM THE BOTTOM	TEMPERATURE °C.	TIME IN MINUTES
PASTA			
LASAGNE	1	220 - 230	50 - 60
PASTA BAKES	1	220 - 230	40
MEAT			
ROAST VEAL	2	190 - 200	80 - 90
LOIN OF PORK	2	190 - 200	80 - 90
SHOULDER OF PORK	2	190 - 200	100 - 110
RABBIT	2	190 - 200	70 - 80
TURKEY BREAST	2	190 - 200	160 - 180
ROAST NECK OF PORK	2	190 - 200	190 - 210
FISH	1 - 2	160 - 170	Depending on size
PIZZA	1 - 2	250	20 - 25
BREAD	1 - 2	200 - 210	40
MUFFINS	2	190 - 200	20 - 25
CONFECTIONERY			
SPONGE CAKE	1 - 2	160 - 170	55 - 60
FRUIT TART	1 - 2	160 - 170	30 - 40
PASTRY	1 - 2	160 - 170	20 - 25
CROISSANTS	1 - 2	160 - 180	25 - 30
JAM TARTS	1 - 2	160 - 170	30 - 35
RICE CAKE	1 - 2	160 - 170	60
ANGEL CAKE	1 - 2	160 - 170	60
ECLAIR	1 - 2	160 - 170	40 - 45
LIGHT SPONGE CAKE	1 - 2	160 - 170	40 - 45

PROVING - DEFROSTING



	TEMPERATURE °C
DEFROSTING FOODS	30
NATURALLY YEAST DOUGHS	35 - 40

For successful proving, a container of water should be placed in the bottom of the oven.



GRILLING



	RUNNER POSITION FROM THE BOTTOM	TIME IN MINUTES	
		1ST SIDE	2ND SIDE
PORK CUTLET	4	7 - 9	5 - 7
PORK FILLET	3	9 - 11	5 - 9
FILLET STEAK	3	9 - 11	9 - 11
SLICED LIVER	4	2 - 3	2 - 3
VEAL ESCALOPES	4	7 - 9	5 - 7
HALF CHICKEN	3	9 - 14	9 - 11
SAUSAGE	3	7 - 9	5 - 6
MEATBALLS	3	7 - 9	5 - 6
FISH FILLET	3	5 - 6	3 - 4
TOASTED SANDWICHES	3	2 - 4	2 - 3

HOT AIR COOKING

ECO



	RUNNER POSITION FROM THE BOTTOM	TEMPERATURE °C.	TIME IN MINUTES
PASTA			
LASAGNE	2	210 - 230	45 - 50
PASTA BAKES	2	210 - 230	25 - 30
MEAT			
ROAST VEAL	2	180 - 190	70 - 80
LOIN OF PORK	2	180 - 190	70 - 80
SHOULDER OF PORK	2	180 - 190	90 - 100
RABBIT	2	180 - 190	70 - 80
TURKEY BREAST	2	180 - 190	110 - 120
ROAST CHICKEN	2	180 - 190	60 - 70
FISH			
SALMON TROUT	2	150 - 160	35 - 40
PIZZA	1 - 2	250	15 - 20
BREAD	1	190 - 200	25 - 30
MUFFINS	1 - 2	180 - 190	15 - 20
CONFECTIONERY			
SPONGE CAKE	2	160	50 - 60
LARGE JAM TART	2	160	25 - 30
PASTRY	2	170	20 - 25
CROISSANTS	2	160 - 170	20 - 25
JAM TARTS	2	160	20 - 25
ANGEL CAKE	2	160	60



Instructions for the User

GB-IE

11. CLEANING AND MAINTENANCE



Before carrying out any operations, disconnect the appliance from the electricity supply.



Never use a jet of steam for cleaning the inside of the oven.

11.1 Cleaning stainless steel



To keep stainless steel in good condition, it must be cleaned regularly, after each use of the oven, after allowing it to cool.

11.2 Routine daily cleaning

When cleaning and caring for stainless steel surfaces, always use **only** specific products which do not contain abrasives or chlorine-based acids.

Instructions for use: pour the product onto a damp cloth and wipe over the surface, then rinse thoroughly and dry with a soft cloth or chamois leather.

11.3 Food stains or spills

Never use metal scouring pads or sharp scrapers; they will damage surfaces.

Use ordinary non-abrasive products with the aid of wooden or plastic utensils if necessary. Rinse thoroughly and dry with a soft cloth or chamois leather.

Do not allow spills of foods with high sugar content (e.g. jam) to dry inside the oven. If they dry for too long, they might damage the enamel coating of the inside of the oven.





11.4 Cleaning the oven



To keep the oven in good condition, it must be cleaned regularly, after allowing it to cool down.

Remove all removable parts.

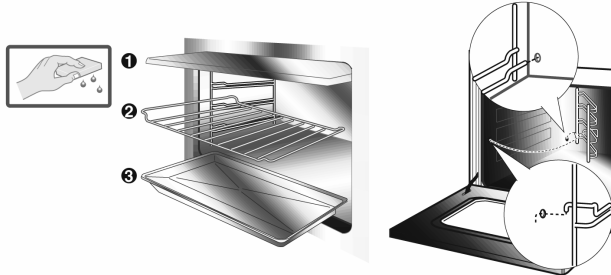

- Clean the oven shelves with hot water and non-abrasive detergents, rinse and dry.
- For easier cleaning, the door can be removed (see point “12.2 Removing the door”)

On some models only:

- To clean the bottom of the oven, proceed as follows with the oven cold.

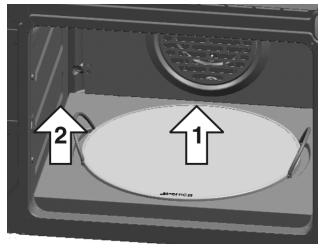

1)

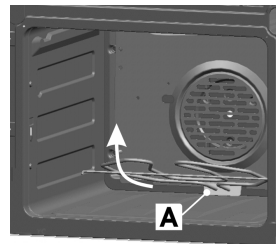

2)

- Remove the pizza plate and then the base to which it is fixed (Fig. 1). Lift the base a few mm and then extract it from the oven.
- Now lift the end of the heating element next to the door of the oven and clean the bottom. When the operation is complete, damp parts should be dried thoroughly.



Instructions for the User

GB-IE

- The oven should be operated at the maximum heat setting for 15/20 minutes after use of specific products, to burn off the residues left inside the oven.
- The pizza plate must be washed separately;
- Before cleaning, remove any dirt burnt onto the stone with the aid of a metal spatula or a scraper of the kind used for cleaning ceramic hobs;
 - For best results, the stone must still be warm; otherwise, wash it in hot water;
 - Use metal mesh or non-abrasive scotch-brite pads, dipped in lemon or vinegar;
 - Never use detergents;
 - Never wash in the dishwasher;
 - Never leave the stone to soak;
 - The damp stone must not be used for a least 8 hours after the end of the cleaning procedures;
 - Over time, slight cracks may appear on the surface of the stone. This is due to the normal expansion of the stone's finishing glazes at high temperatures.
 - To put the pizza plate base back in place, push it firmly down against the oven's bottom panel and ensure it engages with plate of the the pizza heating element (detail **A** Fig. 2)

11.5 Cleaning the oven with self-cleaning liners

The oven is fitted with enamelled liners that are continuously self-cleaning. These liners simplify cleaning of the oven and ensure it continues to perform well over time.

11.5.1 Using the self-cleaning liners

To keep the inside of the oven clean and free from food residues and unpleasant smells, it should periodically be operated empty at a temperature of at least 200° C for a time varying between 30 and 60 minutes. This allows the self-cleaning liners to oxidise any deposits present, which can then be wiped away with a damp sponge once the oven has cooled.

11.5.2 Maintenance of self-cleaning liners

The liners should not be cleaned using abrasive creams and ordinary cleaners. Simply wipe with a damp sponge to avoid damaging the special enamel coating.



11.5.3 Removing the self-cleaning liners

Remove all accessories from the inside of the oven and proceed as follows:

- 4 Remove the side runners (fig.1);
- 5 Extract the side liners "F" and "G" (fig. 2);
- 6 Extract the back liner "A" after undoing the threaded ring-nut "C" (fig. 2);
- 7 Replace the liners in their original positions.

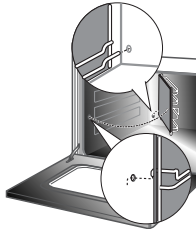

Fig.1

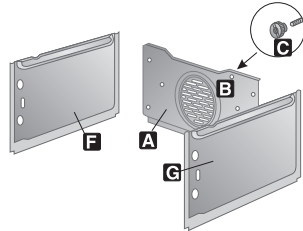

Fig. 2

11.6 Cleaning the door glazing

The glass in the door should always be kept thoroughly clean. Use absorbent kitchen roll; remove stubborn dirt with a damp sponge and ordinary detergent.



Do not use abrasive or corrosive cleaners for cleaning the door glazing. (e.g. powder products, oven-cleaner sprays, stain removers and metal scouring pads).

Do not use rough or abrasive materials or sharp metal scrapers to clean the oven's glass doors since they may scratch the surface and cause the glass to shatter.



Instructions for the Installer

GB-IE

12. EXTRAORDINARY MAINTENANCE

Occasionally, the oven will require minor servicing procedures or the replacement of parts subject to wear and tear, such as gaskets, light bulbs, etc. The specific operations for each procedure of this kind are provided below.



Before carrying out any operation involving access to live parts, disconnect the appliance from the electricity supply.

12.1 Changing the light bulb

Remove the protective cover **A** by unscrewing it anti-clockwise and replace the bulb **B** with another of the same type (25 W). Replace the protective cover **A**.

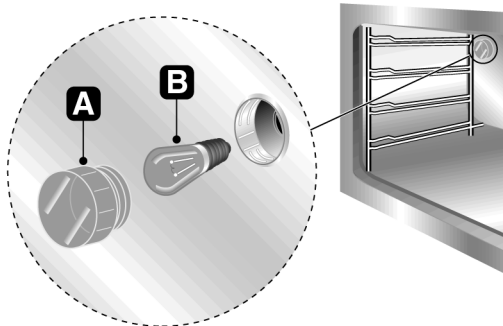

Use only light bulbs approved for ovens (T 300°C).



12.2 Removing the door

12.2.1 With type 1 mobile levers

With the door completely open, lift the levers **A** of the two hinges until they touch the hinges **B** and take hold of the two sides of the door with both hands close to the hinges themselves. Raise the door to an angle of about 45° and remove it. If the hinges have not locked, repeat the operation, raising the levers and keeping the door slightly raised. To reassemble, fit the hinges **B** into their grooves, then lower the door into place, ensuring that it remains fitted into the grooves **C**, then lower the levers **A**.

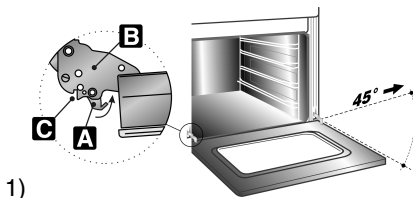

12.2.2 Removing doors with pins

Open the door completely and insert the pins (supplied) into the holes from the inside. Close the door to an angle of about 45° and lift it off. To reassemble, fit the hinges into their grooves, then lower the door into place and extract the pins. If you should lose the pins, two screwdrivers can also be used.

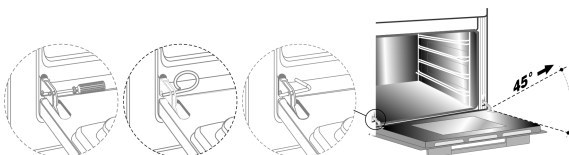

12.3 Removing the inside glass with the door cold

The glass in the door should always be kept thoroughly clean. For easier cleaning, the door glazing can be fully removed by proceeding as described below. After opening the door and locking it in place as described in point "12.2 Removing the door", remove the three panes of glass. They are all removed in two stages: first extract the pane from the guide "A" (see detail) by sliding it towards you and lifting it slightly, then also free it from the guide "B". If the door should close during these operations, simply relock one of the hinges as described in point "12.2 Removing the door". The panes of glass can now be washed separately.



Instructions for the Installer

GB-IE

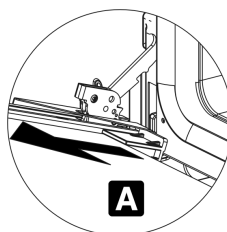
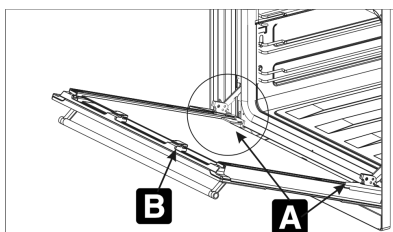

Use absorbent kitchen roll; remove stubborn dirt with a damp sponge and ordinary detergent.



Warning: before removing the panes of glass, make sure that at least one of the door's hinges has been locked in open position as described in points "12.2 Removing the door". This operation might have to be repeated during the glass removal process if the door is accidentally freed.

12.4 Removing the gasket

To allow thorough cleaning of the oven, the door gasket can be removed.

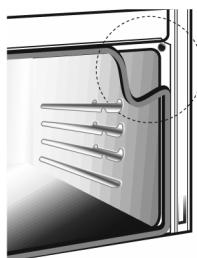



13. INSTALLING THE APPLIANCE

13.1 Electrical connection



The nameplate with the technical data, serial number and mark is in a visible position on the oven door surround.

The nameplate must never be removed.



The appliance must be connected to earth in compliance with electrical system safety regulations.



If a permanent connection is used, the appliance's power supply line must be fitted with an omnipolar breaking device with contact gap of at least **3 mm**, located in an easily accessible position close to the appliance itself.



If a socket and plug connection is used, check that they are of the same type. Do not use reducers, adapters or junctions since they may cause overheating or burns.



Operation at 220-240 V~: use a type H05RR-F (3 x 1.5 mm²) or type H05V2V2-F (3 x 1.5 mm²) three-wire cable.

The earth wire (yellow-green) must be at least 20 mm longer than the other wires at the end for connection to the appliance.

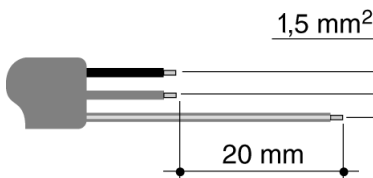



Instructions for the Installer

GB-IE

13.2 Positioning the oven

The appliance is designed for building-in to cabinets made from any heat-resistant material. Comply with the dimensions shown in figures 1, 2, and 3. When installing under worktops, comply with the dimensions shown in figure 1-3. When installing under worktops incorporating combined hobs, a gap of at least 110 mm must be left from any side wall, as shown in figure 1.

When installing in tall units, comply with the dimensions shown in figure 1-2, bearing in mind that the top/rear of the unit must have an opening 80-90 mm deep. Screw the 2 screws **A** into the inside of the frame (fig. 1). For installation under counter-top hobs, make sure that the rear/bottom of the unit has an opening similar to that shown in figure 1 (ref. **B**). See the instructions supplied with the hob for the relative positioning and fixing procedures.

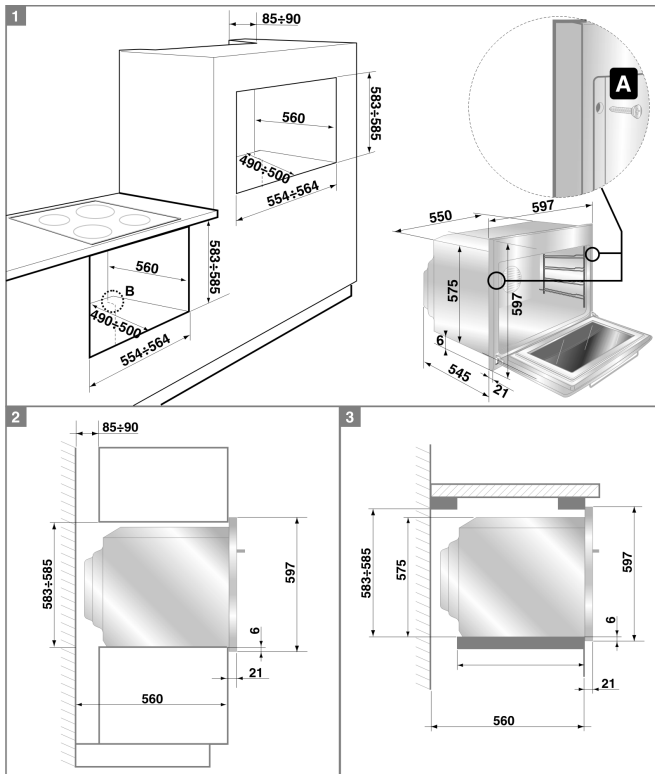

Instructions for the Installer



Never use the door for leverage when inserting the oven in the cabinet. Never apply excessive pressure to the open door.

