

1. PRECAUTIONS FOR USE .....	31
2. DISPOSAL INSTRUCTIONS - OUR ENVIRONMENT POLICY .....	32
3. SAFETY PRECAUTIONS .....	33
4. GET TO KNOW YOUR OVEN .....	34
5. BEFORE INSTALLATION .....	34
6. DESCRIPTION OF FRONT PANEL CONTROLS .....	35
7. USING THE OVEN .....	39
8. ACCESSORIES AVAILABLE .....	41
9. COOKING ADVICE <sup>42</sup>	
10. CLEANING AND MAINTENANCE .....	48
11. EXTRAORDINARY MAINTENANCE .....	53
12. INSTALLING THE APPLIANCE .....	54



**INSTRUCTIONS FOR THE USER:** *these provide recommendations for use, a description of the controls and the correct procedures for cleaning and maintaining the appliance*



**INSTRUCTIONS FOR THE INSTALLER:** *these are intended for the qualified engineer who is to install, commission and test the appliance*

## 1. PRECAUTIONS FOR USE



THIS MANUAL IS AN INTEGRAL PART OF THE APPLIANCE. TAKE GOOD CARE OF IT AND KEEP IT TO HAND THROUGHOUT THE OVEN'S LIFE CYCLE.

WE URGE YOU TO READ THIS MANUAL AND ALL THE INFORMATION IT CONTAINS CAREFULLY BEFORE USING THE APPLIANCE. INSTALLATION MUST BE CARRIED OUT BY QUALIFIED STAFF IN COMPLIANCE WITH THE RELEVANT REGULATIONS. THIS APPLIANCE IS INTENDED FOR HOUSEHOLD USE AND COMPLIES WITH THE **EEC DIRECTIVES** CURRENTLY IN FORCE. THE APPLIANCE IS BUILT TO PROVIDE THE FOLLOWING FUNCTION: **COOKING AND HEATING FOODS**; ALL OTHER USES ARE TO BE CONSIDERED IMPROPER.

THE MANUFACTURER DECLINES ALL LIABILITY FOR USES OTHER THAN THOSE STATED ABOVE.

NEVER USE THIS APPLIANCE FOR HEATING ROOMS.



NEVER USE PACKAGING RESIDUES UNATTENDED IN THE HOME. SEPARATE THE VARIOUS PACKAGING MATERIALS BY TYPE AND CONSIGN THEM TO THE NEAREST SEPARATE DISPOSAL CENTRE.



THIS APPLIANCE IS MARKED ACCORDING TO THE EUROPEAN DIRECTIVE 2002/96/EC ON WASTE ELECTRICAL AND ELECTRONIC EQUIPMENT (WEEE). THIS GUIDELINE IS THE FRAME OF A EUROPEAN-WIDE VALIDITY OF RETURN AND RECYCLING ON WASTE ELECTRICAL AND ELECTRONIC EQUIPMENT.



NEVER OBSTRUCT THE OPENINGS AND SLITS PROVIDED FOR VENTILATION AND HEAT DISPERSAL.



THE NAMEPLATE WITH THE TECHNICAL DATA, SERIAL NUMBER AND MARK ARE IN A VISIBLE POSITION ON THE OVEN DOOR FRAME.

THE NAMEPLATE MUST NEVER BE REMOVED.



NEVER USE METAL SCOURING PADS OR SHARP SCRAPERS; THEY WILL DAMAGE SURFACES.

USE ORDINARY NON-ABRASIVE PRODUCTS WITH THE AID OF WOODEN OR PLASTIC UTENSILS IF NECESSARY. RINSE THOROUGHLY AND DRY WITH A SOFT CLOTH OR CHAMOIS LEATHER.

DO NOT ALLOW SPILLS OF FOODS WITH HIGH SUGAR CONTENT (E.G. JAM) TO DRY INSIDE THE OVEN. IF THEY DRY FOR TOO LONG, THEY MIGHT DAMAGE THE ENAMEL COATING OF THE INSIDE OF THE OVEN.





### **2. DISPOSAL INSTRUCTIONS - OUR ENVIRONMENT POLICY**

Our products are only packaged using non-pollutant, environment-friendly, recyclable materials. We urge you to cooperate by disposing of the packaging properly. Contact your local dealer or the competent local organisations for the addresses of collection, recycling and disposal facilities.

Never leave all or part of the packaging lying around. Packaging parts, and especially plastic bags, may represent a suffocation hazard for children.

Your old appliance must also be disposed of properly.

**Important:** deliver the appliance to your local organisation authorised to collect scrapped appliances. Proper disposal allows the intelligent recovery of valuable materials.

Before scrapping your appliance it is important to remove doors and leave shelves in position as for use, to ensure that children cannot accidentally become trapped inside the oven during play. Also, cut the power supply lead and remove it and the plug.

## 3. SAFETY PRECAUTIONS



SEE INSTALLATION INSTRUCTIONS FOR SAFETY REGULATIONS FOR ELECTRIC OR GAS APPLIANCES AND FOR VENTILATION FUNCTIONS. IN YOUR INTEREST AND TO ENSURE YOUR SAFETY, BY LAW ALL ELECTRIC APPLIANCES MUST ONLY BE INSTALLED AND SERVICED BY QUALIFIED STAFF, IN ACCORDANCE WITH THE RELEVANT REGULATIONS. OUR APPROVED INSTALLATION ENGINEERS GUARANTEE YOU A JOB WELL DONE. GAS OR ELECTRIC APPLIANCES MUST ALWAYS BE DISCONNECTED BY SUITABLY SKILLED PEOPLE.



THE PLUG TO BE CONNECTED TO THE POWER SUPPLY LEAD AND THE RELATIVE SOCKET MUST BE OF THE SAME TYPE AND COMPLY WITH THE RELEVANT REGULATIONS. THE POWER SUPPLY SOCKET MUST BE ACCESSIBLE EVEN AFTER THE APPLIANCE HAS BEEN BUILT-IN. **NEVER DISCONNECT THE PLUG BY PULLING ON THE POWER SUPPLY LEAD.**



THE APPLIANCE MUST BE CONNECTED TO EARTH IN COMPLIANCE WITH ELECTRICAL SYSTEM SAFETY REGULATIONS.



IMMEDIATELY AFTER INSTALLATION, CARRY OUT A QUICK TEST ON THE APPLIANCE FOLLOWING THE INSTRUCTIONS PROVIDED LATER IN THIS MANUAL. IF THE APPLIANCE FAILS TO OPERATE, DISCONNECT IT FROM THE ELECTRICAL MAINS AND CONTACT YOUR NEAREST SERVICE CENTRE. **NEVER ATTEMPT TO REPAIR THE APPLIANCE.**



NEVER PLACE FLAMMABLE OBJECTS IN THE OVEN: IF IT SHOULD ACCIDENTALLY BE SWITCHED ON, THIS MIGHT CAUSE A FIRE.



**THE APPLIANCE BECOMES VERY HOT DURING USE.** TAKE CARE NOT TO TOUCH THE HEATING ELEMENTS INSIDE THE OVEN.



THE USE OF THIS APPLIANCE IS NOT PERMITTED TO PEOPLE (INCLUDING CHILDREN) OF REDUCED PHYSICAL AND MENTAL ABILITY, OR LACKING IN EXPERIENCE IN THE USE OF ELECTRICAL APPLIANCES, UNLESS THEY ARE SUPERVISED OR INSTRUCTED BY ADULTS OR PEOPLE RESPONSIBLE FOR THEIR SAFETY.



BEFORE THE APPLIANCE IS PUT INTO OPERATION, ALL THE LABELS AND PROTECTIVE FILMS APPLIED INSIDE OR OUTSIDE MUST BE REMOVED.



AFTER EACH USE, ALWAYS CHECK THAT THE CONTROL KNOBS ARE TURNED TO 0 (OFF).



*The manufacturer declines all responsibility for injury or damage caused by failure to comply with the above regulations or deriving from tampering with even just one part of the appliance and the use of non-original spare parts.*



## 4. GET TO KNOW YOUR OVEN

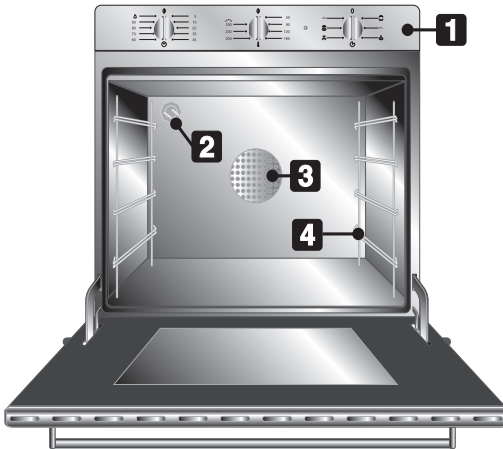

- 1** CONTROL PANEL
- 2** OVEN LIGHT
- 3** HOT AIR FAN (ON SOME MODELS ONLY)
- 4** SHELF AND TRAY RUNNERS

## 5. BEFORE INSTALLATION



Never leave packaging residues unattended in the home. Separate waste packaging materials by type and consign them to the nearest separate disposal centre.



The inside of the appliance should be cleaned to remove all manufacturing residues. For further information, see "10. CLEANING AND MAINTENANCE".



When the oven and grill are used for the first time, they should be heated to the maximum temperature for long enough to burn off any oily residues left by the manufacturing process, which might contaminate foods with unpleasant smells.



# Instructions for the User



## 6. DESCRIPTION OF FRONT PANEL CONTROLS

All the cooker's control and monitoring devices are placed together on the front panel. The table below provides the key to the symbols used.

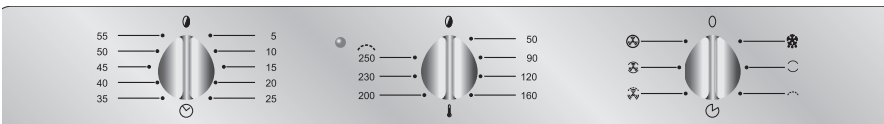
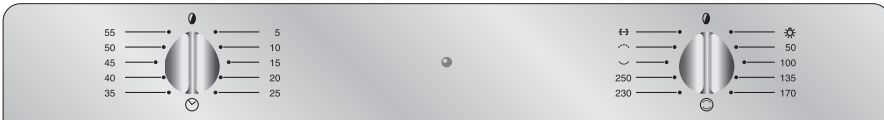

# Instructions for the User



## FUNCTION SELECTOR KNOB (STATIC OVEN)

The cooking temperature is selected by turning the knob clockwise to the value required, between **50°** and **240/250°C** (depending on the model).

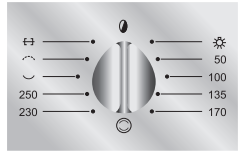

For different heating effects, users can switch on only the bottom heating element ( ☐ ) or only the grill element ( ☐ ). At the end of the knob rotation scale, the ↔ symbol switches on the rotisserie motor and the grill top heating element.

## THERMOSTAT KNOB (MULTIFUNCTION OVEN)

The cooking temperature is selected by turning the knob clockwise to the value required, between **50°** and **240/250°C** (depending on the model).

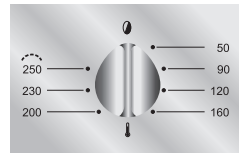
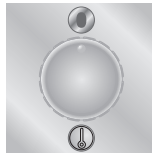

## THERMOSTAT LIGHT

Illuminates to indicate that the oven is heating up. Goes out when the set temperature is reached; flashes at regular intervals to indicate that the temperature inside the oven is being kept constantly at the set level.

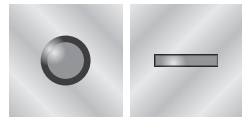



# Instructions for the User



## FUNCTION CONTROL KNOB (MULTIFUNCTION OVEN)

Rotate the knob in either direction to select desired function from the following:



NO FUNCTION SET



THAWING



INSIDE LIGHT (NO HEATING ELEMENTS ON)



TOP+BOTTOM HEATING ELEMENTS+FAN



TOP+BOTTOM HEATING ELEMENTS



GRILL ELEMENT + FAN



GRILL ELEMENT IN OPERATION ALTERNATING WITH BOTTOM HEATING ELEMENT + FAN



FAN HEATING ELEMENT



GRILL ELEMENT



SMALL GRILL ELEMENT + FAN



BOTTOM HEATING ELEMENT



BOTTOM HEATING ELEMENT + FAN



SMALL GRILL ELEMENT



TOP+BOTTOM HEATING ELEMENTS + FAN HEATING ELEMENT

## MINUTE MINDER KNOB

Setting is on a gradual scale and intermediate positions between the numbers can be used. The end of cooking buzzer does not turn off the oven.

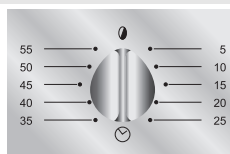





## TIMER KNOB

Allows selection of manual cooking or the minute minder function with the oven automatically switched off at the end of the cooking time. **If no cooking duration is selected, the timer knob must be turned to the  symbol.**

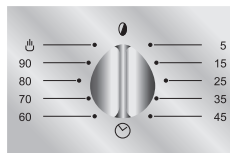
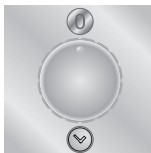

To set the cooking duration, turn the knob clockwise to the "90/120" setting and then set the cooking duration required. Numbers **5** to **90/120** correspond to minutes. Setting is on a gradual scale and intermediate positions between the numbers shown can be used. At the end of the programmed cooking time, a buzzer will sound; it will stop automatically after 4-5 seconds.

### IMPORTANT (ON MODELS WITH INTEGRATED CONTROLS)

To access the control knobs they must first be extracted; simply press them and they will spring out into the operating position on their own (Fig. A). They must remain in this position as long as the oven is in operation as otherwise they may overheat. To return them to the rest position, press them right down until the catch engages. To open the oven door the handle must first be extracted; simply press it and it will spring out into the right position (Fig. B). It must remain in this position as long as the oven is in operation as otherwise it may overheat.

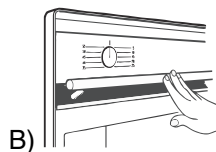
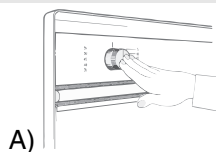



## Instructions for the User

GB-IE

### 7. USING THE OVEN

#### 7.1 Precautions and General Advice

When the oven and grill are used for the first time, they should be heated to the maximum temperature for long enough to burn off any oily residues left by the manufacturing process, which might contaminate foods with unpleasant smells.



*During cooking, do not cover the bottom of the oven with aluminium or tin foil, and do not place pans or oven dishes on it; this may damage the enamel coating. If you wish to use greaseproof paper, position it so that it does not interfere with the hot air circulation inside the oven.*



*Oven accessories which may come into contact with foods are made from materials compliant with EEC directive 89/109 of 21/12/88 and national relevant regulations.*



*To avoid unpleasant contact with any steam inside the oven, open the door in two stages; hold it open just a little (about 5 cm) for 4-5 seconds, then open it completely. If you have to check or carry out other procedures on food during cooking, leave the door open for as short a time as possible to prevent a drop in the oven temperature which will impair the cooking results. When the door is opened the oven's internal fan cuts out automatically; it starts up again when the door is closed (Depending on models).*





## 7.2 Cooling fan system (on some models only)

The appliance is equipped with a cooling system which comes into operation when the oven is switched on. The operation of the fans generates a normal air flow which comes out above the door depending on the model, and may continue for a short time even after the oven is switched off.

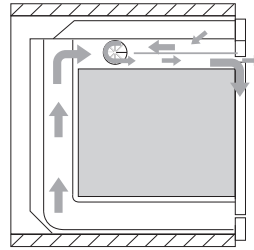

## 7.3 Inside light (Depending on models)

Depending on the model, the oven light switches on:

- when the oven door is opened, or;
- when function knob is turned to any function, or;
- when the function knob is turned to the  symbol.



## Instructions for the User

GB-IE

### 8. ACCESSORIES AVAILABLE

The oven is fitted with **4 runners** for placing trays and shelves at different heights.



**Shelf:** useful to support pans containing the food for cooking.



**Tray grid:** for placing on top of a tray for cooking foods which may drip.



**Oven tray:** useful for collecting fat from foods placed on the grid above.

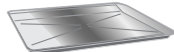

**Pastry tray:** useful for cooking cakes, pizza and confectionery.

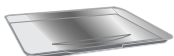

**Roof liner:** remove it to simplify cleaning inside the oven.

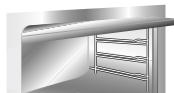

**Rotisserie shelf (models with static oven only):** for fitting onto the oven runners before the rotisserie rod is used.



**Rotisserie rod (models with static oven only):** useful for cooking chicken, sausages and all foods which require uniform cooking over their entire surface.



**Chromium-plated gripper:** useful for removing hot shelves and trays.



*Not all accessories are provided on some models.*

#### **Optional accessories**

*Original accessories can be ordered through our Authorised Service Centres.*



## 9. COOKING ADVICE



The oven should always be preheated in fan mode to 30/40°C above the cooking temperature. This considerably shortens cooking times and reduces electricity consumption, as well as giving better results.



The oven door must be closed during cooking operations.

### 9.1 Conventional cooking



<b>FUNCTION SELECTOR</b>	
<b>THERMOSTAT</b>	<b>50 ÷ 250 °C</b>



This conventional cooking method, with heat from above and below, is suitable for cooking food on just one shelf. The oven must be preheated to the chosen temperature. Do not place the food in the oven until the thermostat light goes out. Place frozen meat in the oven directly, without thawing. The only precaution required is to set temperatures about 20°C lower and cooking times about 1/4 longer than for fresh meat.

### 9.2 Hot air cooking



<b>FUNCTION SELECTOR</b>	
<b>THERMOSTAT</b>	<b>50 ÷ 250 °C</b>



This system is suitable for cooking on several shelves, even with foods of different kinds (fish, meat, etc.) without cross-contamination of flavours or smells. The air circulation inside the oven ensures uniform heat distribution.



Multiple cooking is possible provided that all foods require the same temperature.



# Instructions for the User



## 9.3 Delicate cooking

<b>FUNCTION SELECTOR</b>	
<b>THERMOSTAT</b>	<b>50 ÷ 250 °C</b>



This type of cooking, for which it is extremely important to preheat the oven in fan mode, is particularly suitable for finishing cooking of foods underneath, or for processes which require heat mainly from below. The tray should be placed on the bottom runner.

## 9.4 Grilling

<b>FUNCTION SELECTOR</b>	
<b>THERMOSTAT</b>	<b>250</b>



Used for quick browning of foods. For short processes and small amounts, place the shelf on the fourth runner from the bottom. For longer cooking times and grilling, place the shelf on lower runners, depending on the size of the food.



**Keep the door closed during grilling. Grilling with the door open may permanently damage the oven and reduce operating safety.**

## 9.5 Hot air grilling

<b>FUNCTION SELECTOR</b>	
<b>THERMOSTAT</b>	<b>200 °C</b>



Allows uniform heat distribution with better penetration to the core of foods. Foods are lightly browned on the outside but still soft on the inside. During cooking the oven door must be closed, and the maximum heating time must not exceed 60 minutes.

# Instructions for the User



*Keep the door closed during grilling. Grilling with the door open may permanently damage the oven and reduce operating safety.*

## 9.6 Thawing



**FUNCTION SELECTOR**



**THERMOSTAT**

**0**



The air movement provided by the hot air fan alone thaws foods more quickly. The air circulating inside the oven is at room temperature.



*Thawing at room temperature has the advantage that the food's flavour and appearance are retained intact.*



# Instructions for the User

GB-IE

## 9.7 Rotisserie cooking (models with static oven only)



**THERMOSTAT**



Prepare the rotisserie rod with the food, tightening the screws **A** of the prongs. Fit the shelf **B** onto the third runners from the bottom. Remove the handle **D** and position the rotisserie rod so that the pulley **E** is still in the guides on the shelf **B**. Push the shelf **B** fully in until the tip of the rotisserie rod enters the hole **C** on the rear of the oven. Place a drip tray **F** on the bottom runner and pour a little water into it to prevent smoke from forming.



*It is normal for the thermostat light to switch on and off at regular intervals during cooking; it indicates that the temperature inside the oven is being kept constant.*

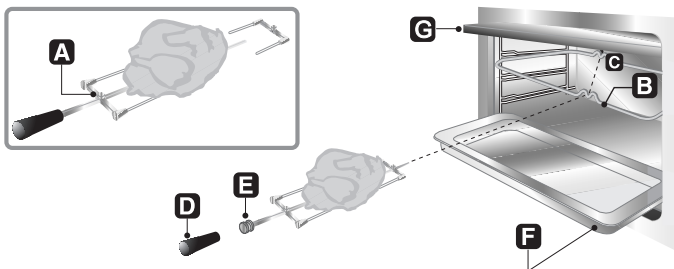





## 9.8 Recommended cooking tables

Cooking times, for meat in particular, vary depending on the food's thickness and quality and personal preference. All times are calculated with the oven preheated.

<b>CONVENTIONAL COOKING</b>			
	RUNNER POSITION FROM THE BOTTOM	TEMPERATURE °C.	TIME IN MINUTES
<b>PASTA</b>			
LASAGNE	2 - 3	210 - 230	30
PASTA BAKES	2 - 3	210 - 230	40
<b>MEAT</b>			
ROAST VEAL	2	170 - 200	30 - 40 PER Kg.
ROAST BEEF	2	210 - 240	30 - 40 PER Kg.
ROAST PORK	2	170 - 200	30 - 40 PER Kg.
CHICKEN	2	170 - 200	45 - 60
DUCK	2	170 - 200	45 - 60
GOOSE-TURKEY	2	140 - 170	45 - 60
RABBIT	2	170 - 200	50 - 60
LEG OF LAMB	2	170 - 200	40 - 50
<b>FISH</b>	1 - 2	170 - 200	Depending on size
<b>PIZZA</b>	1 - 2	210 - 240	40 - 45
<b>CONFECTIONERY</b>			
PASTRY	1 - 2	170 - 200	15 - 20
SPONGE CAKE	1 - 2	165	35 - 45
CROISSANTS	1 - 2	170 - 200	40 - 45
FRUIT CAKE	1 - 2	170 - 200	20 - 30
ANGEL CAKE	1 - 2	170	60
APPLE CAKE	1 - 2	190	60
RICE CAKE	1 - 2	180	60

<b>GRILLING</b>			
	RUNNER POSITION FROM THE BOTTOM	TIME IN MINUTES	
		1ST SIDE	2ND SIDE
PORK CHOP	4	7 - 9	5 - 7
PORK FILLET	3	9 - 11	5 - 9
FILLET STEAK	3	9 - 11	9 - 11
SLICED LIVER	4	2 - 3	2 - 3
VEAL ESCALOPES	4	7 - 9	5 - 7
HALF CHICKEN	3	9 - 14	9 - 11
SAUSAGE	4	7 - 9	5 - 6
MEATBALLS	4	7 - 9	5 - 6
FISH FILLET	4	5 - 6	3 - 4
TOASTED SANDWICHES	4	2 - 4	2 - 3



# Instructions for the User



## HOT AIR COOKING



	RUNNER POSITION FROM THE BOTTOM	TEMPERATURE °C.	TIME IN MINUTES
<b>PASTA</b>			
LASAGNE	2	190 - 210	20 - 25
PASTA BAKES	2	190 - 210	25 - 30
CREOLE RICE	2	190 - 210	20 - 25
<b>MEAT</b>			
ROAST VEAL	2	150 - 170	65 - 90
ROAST PORK	2	150 - 160	70 - 100
ROAST BEEF	2	160 - 170	65 - 90
FILLET STEAK	2	160 - 180	35 - 45
ROAST LAMB	2	130 - 150	100 - 130
RARE ROAST BEEF	2	170 - 180	40 - 45
ROAST CHICKEN	2	170	70 - 90
ROAST DUCK	2	160 - 170	100 - 160
ROAST TURKEY	2	150 - 160	160 - 240
ROAST RABBIT	2	150 - 160	80 - 100
ROAST HARE	2	160 - 170	30 - 50
ROAST PIGEON		140 - 170	15 - 25
<b>FISH</b>	2 - 3	150 - 170	Depending on size
<b>PIZZA</b>	2 - 3	210 - 240	30 - 50
<b>BREAD</b>	2 - 3	190 - 210	40
<b>TOASTED SANDWICHES</b>	1 - 2	220 - 240	7
<b>CONFECTIONERY</b>			
SPONGE CAKE	2 - 3	150 - 160	35 - 45
FRUIT CAKE	2 - 3	150 - 160	40 - 50
CROISSANTS	2 - 3	150 - 160	40 - 60
PASTRY	2 - 3	150 - 160	25
RICE CAKE	2 - 3	150 - 160	65
APPLE CAKE	2 - 3	150 - 160	65
ANGEL CAKE	2 - 3	150 - 160	65

# Instructions for the User



## 10. CLEANING AND MAINTENANCE



Before carrying out any operations, disconnect the appliance from the electricity supply.



Never use a jet of steam for cleaning the inside of the oven.

### 10.1 Cleaning stainless steel



To keep stainless steel in good condition, it must be cleaned regularly, after each use of the oven, after allowing it to cool.

### 10.2 Routine daily cleaning

When cleaning and caring for stainless steel surfaces, always use **only** specific products which do not contain abrasives or chlorine-based acids.  
**Instructions for use:** pour the product onto a damp cloth and wipe over the surface, then rinse thoroughly and dry with a soft cloth or chamois leather.

### 10.3 Food stains or spills

Never use metal scouring pads or sharp scrapers; they will damage surfaces.

Use ordinary non-abrasive products with the aid of wooden or plastic utensils if necessary. Rinse thoroughly and dry with a soft cloth or chamois leather.

Do not allow spills of foods with high sugar content (e.g. jam) to dry inside the oven. If they dry for too long, they might damage the enamel coating of the inside of the oven.





## Instructions for the User

GB-IE

### 10.4 *Cleaning the oven*



*To keep the oven in good condition, it must be cleaned regularly, after allowing it to cool down.*

*Remove all removable parts.*



- Clean the oven shelves with hot water and non-abrasive detergents, rinse and dry.
- For easier cleaning, the door can be removed (see point “10.6 Removing the door”)

### 10.5 *Cleaning the oven with self-cleaning liners (on some models only)*

The oven is fitted with enamelled liners that are continuously self-cleaning. These liners simplify cleaning of the oven and ensure it continues to perform well over time.

#### 10.5.1 **Using the self-cleaning liners**

To keep the inside of the oven clean and free from food residues and unpleasant smells, it should periodically be operated empty at a temperature of at least 200° C for a time varying between 30 and 60 minutes. This allows the self-cleaning liners to oxidise any deposits present, which can then be wiped away with a damp sponge once the oven has cooled.

#### 10.5.2 **Maintenance of self-cleaning liners**

The liners should not be cleaned using abrasive creams and ordinary cleaners. Simply wipe with a damp sponge to avoid damaging the special enamel coating.



## 10.5.3 Removing the self-cleaning liners

Remove all accessories from the inside of the oven and proceed as follows:

- 1 Remove the side runners (fig.1);
- 2 Extract the side liners "F" and "G" (fig. 2);
- 3 Extract the back liner "A" after undoing the threaded ring-nut "C" (fig. 2);
- 4 Replace the liners in their original positions.

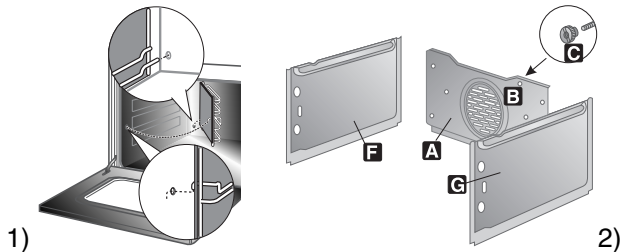

## 10.6 Removing the door

### 10.6.1 Removing doors with mobile hinges

With the door completely open, lift the levers **A** of the two hinges until they touch the hinges **B** and take hold of the two sides of the door with both hands close to the hinges themselves. Raise the door to an angle of about 45° and remove it. If the hinges have not locked, repeat the operation, raising the levers **A** and keeping the door slightly raised. To reassemble, fit the hinges **B** into their grooves, then lower the door into place, ensuring that it remains fitted into the grooves **C**, then lower the levers **A**.

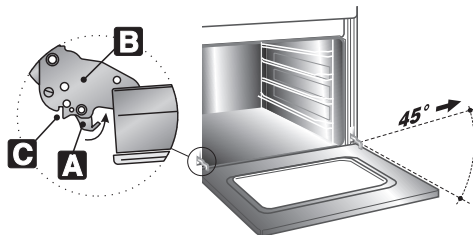



## Instructions for the User

GB-IE

### 10.6.2 Removing doors with pins

Open the door completely and insert the pins (supplied) into the holes from the inside. Close the door to an angle of about 45° and lift it off. To reassemble, fit the hinges into their grooves, then lower the door into place and extract the pins.

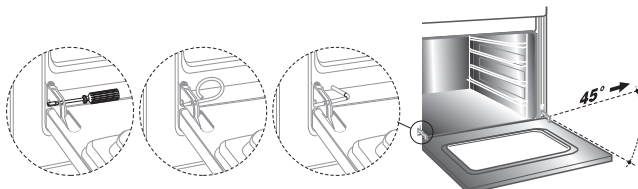

### 10.7 Removing the door glazing

The glass in the door should always be kept thoroughly clean. For easier cleaning, the door glazing can be fully removed by proceeding as described below. After blocking the door in position as described in point "10.6 Removing the door", remove the inner glass using leverage as shown in figure 1, and release the 4 pins which fix the glass to the door. If your oven also has the middle glass (figure 2) this can simply be lifted out. After cleaning, first fit the middle glass (if featured on your oven) and then replace the inner glass, using the oven door supports as a fulcrum as shown in figure 3 (see detail A in figure 3. Once the glass has been fitted on the door, apply a little pressure against the 4 fixing pins.

If the door should close during these operations, simply relock one of the hinges as described in point "10.6 Removing the door". The panes of glass can now be washed separately.

# Instructions for the User

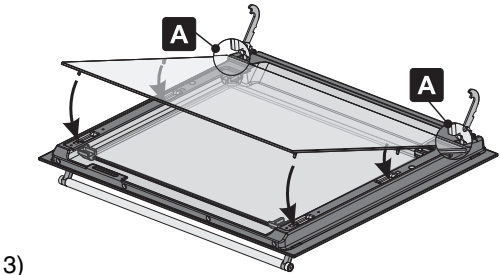
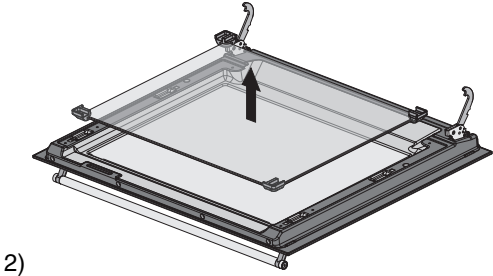
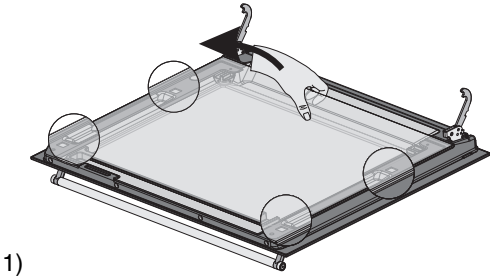

Use absorbent kitchen roll; remove stubborn dirt with a damp sponge and ordinary detergent.



*Warning: before removing the panes of glass, make sure that the door has been locked in open position as described in points "10.6 Removing the door". This operation might have to be repeated during the removal process if the door is accidentally freed.*



*To replace the panes of glass in the oven door, follow the instructions provided in reverse order.*  
**WARNING.** Never use the oven without the glass fitted: the outside surface of the door overheats



# Instructions for the User

GB-IE

## 11. EXTRAORDINARY MAINTENANCE

Occasionally, the oven will require minor servicing procedures or the replacement of parts subject to wear and tear, such as gaskets, light bulbs, etc. The specific operations for each procedure of this kind are provided below.



*Before carrying out any operation involving access to live parts, disconnect the appliance from the electricity supply.*

### 11.1 Changing the light bulb

Remove the protective cover **A** by unscrewing it anti-clockwise and replace the bulb **B** with another of the same type (25 W). Replace the protective cover **A**.

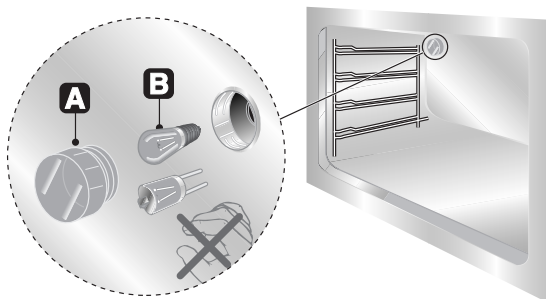

*Use only light bulbs approved for ovens (T 300°C).*

**8-function model with glass front panel.** The standard light bulbs are of halogen type **do not touch them with your fingers**, wrap them in an insulating material. Use only light bulbs available from our Authorised Service Centres.

### 11.2 Removing the gasket

To allow thorough cleaning of the oven, the door gasket can be removed.

Before removing the gasket, remove the oven door as described above. Once the door has been removed, lift the tangs at the corners as shown in the figure.

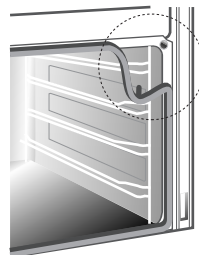





## 12. INSTALLING THE APPLIANCE

### 12.1 Electrical connection



The nameplate with the technical data, serial number and mark is in a visible position on the oven door frame.

The nameplate must never be removed.



The appliance must be connected to earth in compliance with electrical system safety regulations.



If a permanent connection is used, the appliance's power supply line must be fitted with an omnipolar breaking device with contact gap of at least **3 mm**, located in an easily accessible position close to the appliance itself.



If a socket and plug connection is used, check that they are of the same type. Do not use reducers, adapters or junctions since they may cause overheating or burns.



**Operation at 220-240 V~:** use a H05RR-F three-wire cable (cable of  $3 \times 1.5 \text{ mm}^2$ ).

The earth wire (yellow-green) must be at least 20 mm longer than the other wires at the end for connection to the appliance.

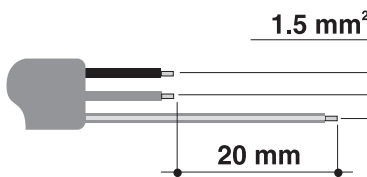



# Instructions for the Installer

GB-IE

## 12.2 Positioning the oven

The appliance is designed for building-in to cabinets made from any heat-resistant material. Comply with the dimensions shown in figures 1, 2, and 3. When installing under worktops, comply with the dimensions shown in figure 1-3. When installing under worktops incorporating combined hobs, a gap of at least 110 mm must be left from any side wall, as shown in figure 1. When installing in tall units, comply with the dimensions shown in figure 1-2, bearing in mind that the top/rear of the unit must have an opening 80-90 mm deep. Screw the 4 screws **A** into the inside of the frame (fig. 1). For installation under tops, make sure that the rear/bottom of the unit has an opening similar to that shown in figure 1 (ref. **B**). See the instructions supplied with the hob for the relative positioning and fixing procedures.

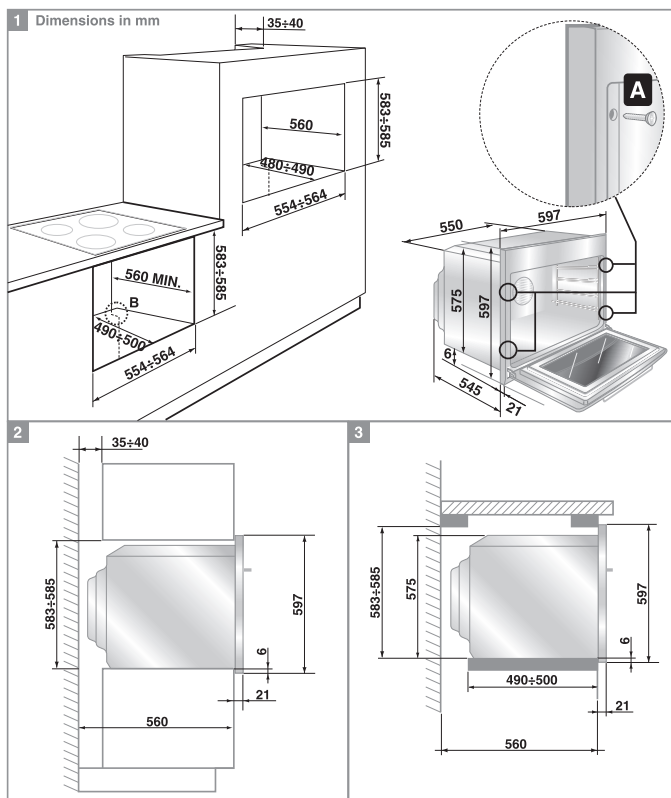

## Instructions for the Installer



*Never use the door for leverage when inserting the oven in the cabinet. Never apply excessive pressure to the open door.*

