

Technical data sheet for

GAS GRIDDLE CONVECTION ELECTRIC OVEN RANGE 900mm

GP8910GEC



- Heavy-duty thermostatic gas griddle
- 20mm thick griddle plate
- Ribbed plate options
- Chromed mirror plate options
- Top weld sealed plates
- 80MJ thermostatic griddle burner system
- Separate left and right heat zones
- GN 2/1 6.6kW electric convection oven
- Drop down door
- Stainless steel exterior
- Easy clean
- Easy service
- Fully modular

Overall Construction

- Galvanized steel chassis
- Welded hob surround with 1.5mm 304 stainless steel bull nose
- Splashback and hob sides 1.2mm 304 stainless steel
- Front panels and oven sides 0.9mm 304 stainless steel
- 150mm legs in 63mm dia. heavy-duty 1.2mm 304 stainless steel with adjustable feet

GRIDDLE

- 20mm thick machined top plates standard
- Optional ribbed plate sections
- Optional mirror finish hard chrome plates
- 2.5mm thick 304 stainless steel splash guards sides and rear
- 2.0mm thick grease channel
- Two 40MJ 3 bar even heat burners with dual thermostatic controls
- Full pilot and flame failure protection with piezo ignition
- Stainless steel grease drawer
- Overlapping finish at front and rear of plate for easy clean

OVEN

- Fully welded and vitreous enamelled oven liner
- GN 2/1 capacity with 4 position racking
- Heavy-duty easy remove heavy wire chrome rack supports
- Cast iron even heat oven sole plate
- 6.5kW heating elements
- 100W heavy-duty motor
- 200mm diameter heavy-duty circulation fan
- Welded frame drop down door with heavy-duty spring hinge system
- 0.9mm 304 stainless steel door outer
- 1.0mm press formed vitreous enamelled door inner
- High density fibreglass insulated
- Stay cool stainless steel door handle with cast metal handle mounts
- Supplied with two chrome wire oven racks

Controls

- Large easy use control knobs - heat resistant reinforced
- Easy view control settings on knobs

GRIDDLE

- Separate left and right side heat zones
- Two 90-300°C thermostats
- Flame failure pilot burners
- Piezo ignition to each pilot burner

OVEN

- 50-320°C thermostatic control
- Indicator lights for power and heating

Cleaning and Servicing

- All models with easy clean stainless steel external finish
- Plate is finished front and rear with overlap construction to remove cleaning traps
- Control service and gas conversion through front of unit
- Burner service requires plate removal
- Removable oven racking and sole plate
- Easy clean vitreous enamel oven and door inner
- Door hinge spring adjustable on unit (door outer removed)
- Door disengages for lift off removal and increased service access
- Access to all parts from front of unit

Technical data sheet for

GAS GRIDDLE CONVECTION ELECTRIC OVEN RANGE 900mm

Waldorf
800 SERIES

Specifications

Burners

Two 40MJ 3 bar chromed steel burners - Griddle
Individual pilot, flame failure and piezo ignition

Elements

4.5kW bottom heat element
2.0kW top heat element

Oven Fan Motor

100W

Gas power

80MJ/hr, 22.2kW

Electrical requirements

6.6kW

1 phase connection:

230-240Vac, 50/60Hz, 1P+N+E, 27.7A

3 phase connection:

400-415Vac, 50/60Hz, 3P+N+E

L1 9.4A

L2 9.4A

L3 8.3A

Plate

Cooking surface 892mm x 530mm, 4728cm²

Oven Dimensions

Width 665mm

Depth 590mm

Height 385mm

Rack size 660mm x 540mm

Rack positions 4

Gas connection

R ³/₄ (BSP) male

130mm from RH side, 32mm from rear,
and 655mm from floor

Optional underside connection
(refer specification drawing)

All units supplied with Natural and LP gas regulator

Electrical connection

25mm from RH side, 484mm from rear,
and 150mm from floor

DIMENSIONS

Width 900mm

Depth 805mm

Height 915mm

Incl. splashback 1130mm

PACKING DATA

1.02m³

Width 940mm

Depth 865mm

Height 1255mm

GAS TYPES

Available in Natural gas and LP gas

Please specify when ordering

Units supplied complete with gas type
conversion kits

Other gas types on request

OPTIONS AT EXTRA COST

Joining caps

Castors

Plinth mounting

Ribbed plate options

Chromed plate options

GP8910GEC

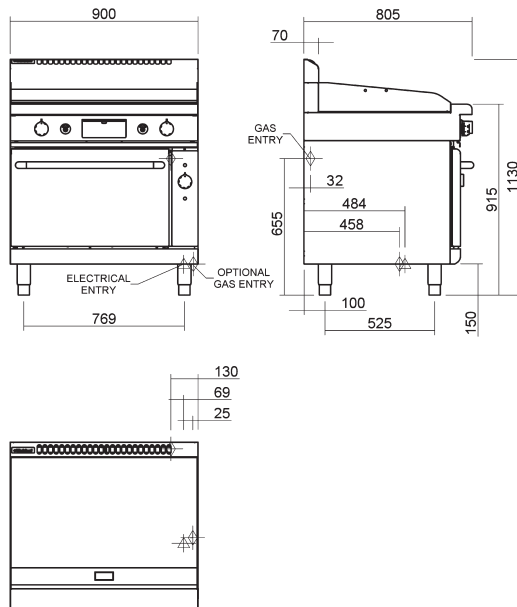

MOFFAT

Australia
www.moffat.com.au
New Zealand
www.moffat.co.nz

Australia
Moffat Pty Limited

Victoria/Tasmania
740 Springvale Road
Mulgrave, Victoria 3170
Telephone 03-9518 3888
Facsimile 03-9518 3833
vsales@moffat.com.au

New South Wales
Telephone 02-8833 4111
nswsales@moffat.com.au

South Australia
Telephone 03-9518 3888
vsales@moffat.com.au

Queensland
Telephone 07-3630 8600
qldsales@moffat.com.au

Western Australia
Telephone 08-9562 0263
jberent@moffat.com.au

New Zealand
Moffat Limited

Christchurch
Telephone 03-389 1007
sales@moffat.co.nz

Auckland
Telephone 09-574 3150
sales@moffat.co.nz



ISO9001
Quality
Management
Standard

Designed and manufactured by

MOFFAT

ISO9001
All Waldorf products are designed and
manufactured by Moffat using the
internationally recognised ISO9001 quality
management system, covering design,
manufacture and final inspection, ensuring
consistent high quality at all times.

In line with policy to continually develop and
improve its products, Moffat Limited reserves
the right to change specifications and design
without notice.

Printed in New Zealand
© Copyright Moffat Limited
Moffat/4639/BH/1M/8.05

