

Operating instructions

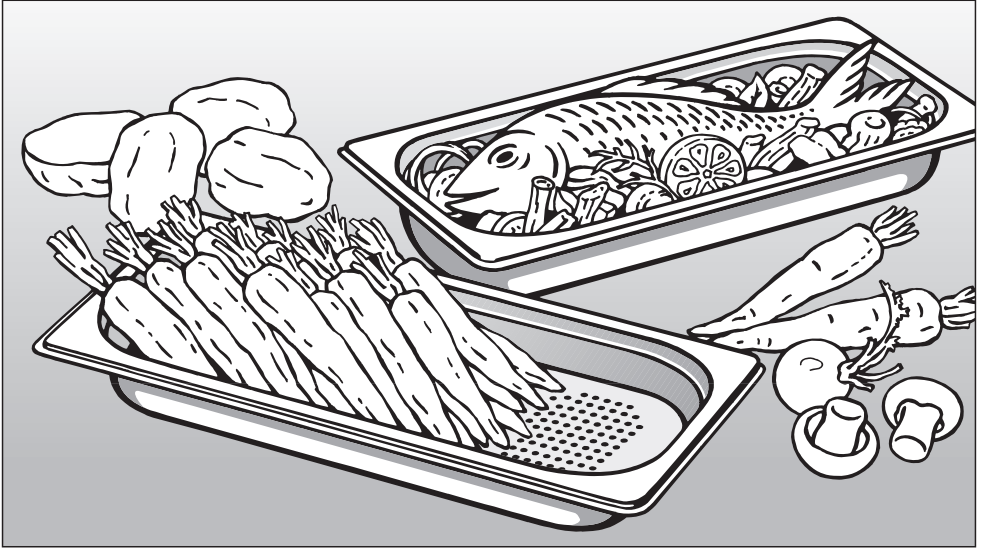

Steam oven

DG 4064 / DG 4164

DG 4064 L / DG 4164 L

To avoid the risk of accidents or damage to the appliance it is **essential** to read these instructions before it is installed and used for the first time.

en - GB

Contents

Description of the appliance	4
Front view	4
Controls and displays	5
Accessories supplied	6
Optional accessories	7
Warning and Safety instructions	9
Caring for the environment	14
Before using for the first time	15
Setting the water hardness level	15
Location	15
Opening and closing the door	16
Cleaning and heating up for the first time	17
Operation	18
Before each use	18
Programming steps in brief	18
Programme chart	19
Switching on and selecting a programme	20
Altering the recommended temperature	20
Setting a cooking duration	21
Starting a programme	21
Interrupting a programme	22
Changing a programme	23
At the end of the cooking duration	24
After use	25
Practical tips	26
Suitable containers	26
Steaming	27
Reheating	31
Defrosting	32
Cooking whole meals	34
Blanching	34

Contents

Bottling	35
Extracting juice with steam	36
Disinfecting containers	37
Preparing yoghurt	37
Safety features	38
Pressure release / Safety valve	38
Overheating protection	40
Safety lock	41
Cleaning and care	42
General notes	42
Appliance front	42
Cooking containers and drain filter	43
Door seal	43
Safety valve	43
Cooking compartment and pull-out shelf	44
Shelf runners	45
Water nozzle	46
Descaling	47
Programming	50
Problem solving guide	52
Services	55
Technical data	55
Plumbing	55
Electrical connection	55
After sales service, data plate	57

Description of the appliance

Front view

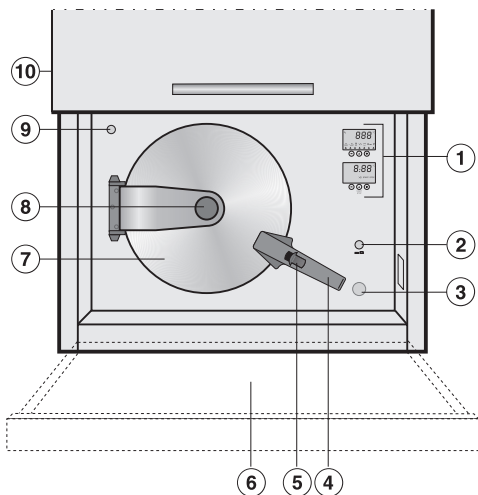

- ① Controls and displays
- ② On/Off button
- ③ Overheating protection device cover cap
- ④ Door handle
- ⑤ Door release
- ⑥ Pull-out shelf
- ⑦ Appliance door
- ⑧ Door button
- ⑨ Opening for adding descaling agent
- ⑩ Lift-up door (only on appliances with an "L" in the model number)

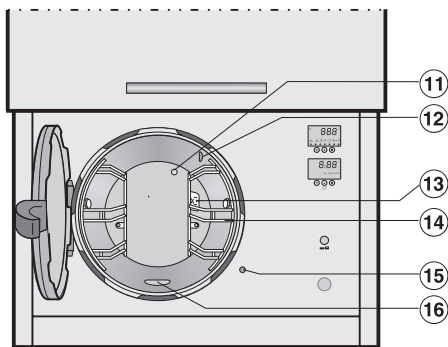

- ⑪ Temperature sensor
- ⑫ Steam vent
- ⑬ Deflector plate for water nozzle
- ⑭ Shelf runners
- ⑮ Door contact switch
- ⑯ Drain filter

Controls and displays

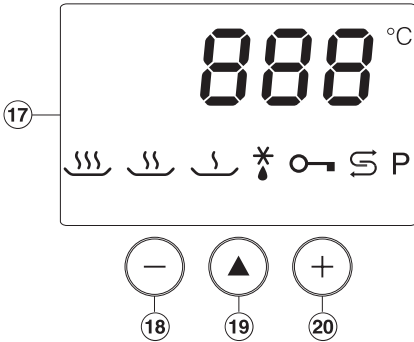

①7 Programme/temperature display with symbols for the following programmes:

☺☺☺ Steam with pressure

☺☺ Steam without pressure

☺ Reheat

❄️ Defrost

🔑 Safety lock

S Descal

P Programming

①8 Temperature button -

①9 Programme button ▲

②0 Temperature button +

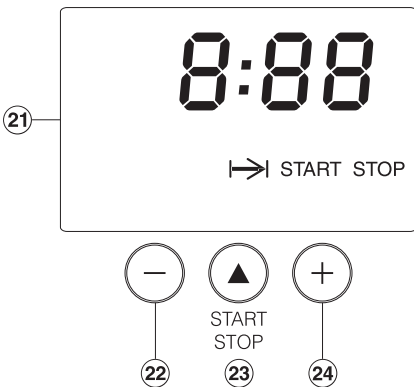

②1 Time display with symbol for:

➔ Duration of programme

②2 Time button -

②3 Start/Stop button ▲

②4 Time button +

Description of the appliance

Accessories supplied

Additional accessories can be ordered at extra cost. See "Optional accessories".

2 cooking containers DGGL 1, perforated (gross capacity 1.5 litres/ usable capacity 0.9 litres)

For steaming
Gastronorm size GN 1/3
325x175x40 mm (WxDxH)

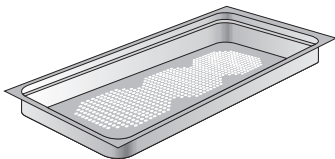

1 cooking container DGG 2, solid (gross capacity 2.5 litres/ usable capacity 2.0 litres)

For cooking food in sauces and stock,
as well as for pasta and rice
Gastronorm size GN 1/3
325x175x65 mm (WxDxH)

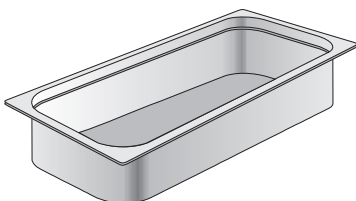

1 tray

For placing your own dishes on

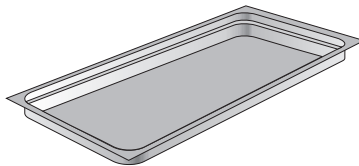

Descaling agent

Product specifically designed for
descaling this steam oven

Silicone washers

For pressure release



Dispensing syringe for descaling agent

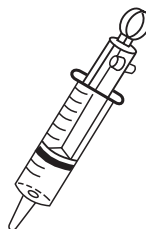





Cook book

Description of the appliance

Optional accessories

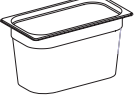
Stainless steel containers

Item		Use	Gross/usable capacity in litres	Height in mm	Width x Depth in mm
	DGGL 5 perforated (GN 1/3)*	For cooking vegetables, fish, meat and potatoes	2.5 / 2.0	65	325 x 175
	DGGL 6 perforated (GN 1/3)	As DGGL 5, but deeper	4.0 / 2.8	100	325 x 175
	DGG 7 solid (GN 1/3)	For cooking a medium sized quantity of soup or a medium sized casserole	4.0 / 2.8	100	325 x 175
	DGG 9 solid (GN 1/3)	As DGG 7, but deeper	5.7 / 4.2	150	325 x 175
	DGGL 10 perforated (GN 1/3)	As DGGL 5, but deeper	5.7 / 4.2	150	325 x 175
	DGD	Lid for cooking containers	-	-	-

* Gastronorm size

1/3 indicates the width and depth of the container.

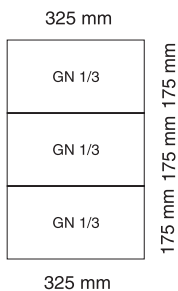

Description of the appliance

Other accessories

Item	Use
Microfibre E-Cloth	For cleaning surfaces such as stainless steel, glass, plastic and chrome without the use of chemicals

Miele accessories are available from

- your Miele dealer or
- the Miele Spare Parts Department (see back cover for contact details)
- the internet on www.miele-shop.com

Warning and Safety instructions

This appliance complies with all relevant legal safety requirements. Improper use of the appliance can, however, present a risk of both personal injury and material damage.

To avoid risk of accidents and damage to the appliance, please read these instructions carefully before installation and before using it for the first time. They contain important notes on the safety, operation and care of the appliance.

This appliance is not intended for use by persons (including children) with reduced physical, sensory or mental capabilities, or lack of experience and knowledge, unless they are supervised whilst using it, or have been given instruction concerning its use by a person responsible for their safety.

Stick the extra data plate supplied with the appliance in the space provided later in these instructions under "After sales service, data plate".

Keep these instructions in a safe place, and pass them on to any future user.

Installation and connection

► The appliance must be installed and connected by a suitably qualified and competent person in strict accordance with current local and national electrical and plumbing safety regulations. The manufacturer cannot be held liable for damage caused by incorrect installation or connection.

► The electrical safety of this appliance can only be guaranteed when continuity is complete between it and an effective earthing system which complies with current local and national safety regulations. It is most important that this basic safety requirement is present and tested regularly, and where there is any doubt, the household wiring system should be inspected by a qualified electrician. The manufacturer cannot be held liable for the consequences of an inadequate earthing system (e.g. electric shock).

► Do not connect the appliance to the mains electricity supply by an extension lead. Extension leads do not guarantee the required safety of the appliance (e.g. danger of overheating).

► This appliance may only be used in mobile installations such as ships, caravans, aircraft etc. if a risk assessment of the installation has been carried out by a suitably qualified engineer.

Warning and Safety instructions

▶ The top edge of the appliance door should not be above eye level. If it is too high, you will find it difficult to access all levels safely when putting dishes into the oven and taking them out, and there is a danger of food spillages and possible scalding.

Correct usage

▶ For safety reasons this appliance must only be operated after it has been built in. This is necessary to ensure that all electrical components are shielded.

▶ This appliance is intended for domestic use only and is not to be used for commercial purposes.

▶ This appliance must only be used as described in these instructions. Any other usage is at the owner's risk and could be dangerous. The manufacturer cannot be held liable for damage resulting from incorrect or improper use or operation.

▶ Make sure that the stopcock is open before using the appliance. After switching off the appliance, remember to close the stopcock to avoid any risk of water damage.

▶ Appliances with lift-up door: Leave the lift-up door open whenever the appliance is being used.

▶ Do not use the appliance without the filter in the bottom of the cooking compartment in place. Otherwise coarse soiling could get into the drainage system and pump, causing a blockage.

▶ Descaling must only be carried out when the appliance is cold to prevent harmful vapours forming. See "Descaling".

▶ Wipe out the appliance with a cloth after each use and leave the door open until the moisture in the cooking compartment has dissipated.

▶ If the appliance is not going to be used for a longer period of time, e.g. whilst on holiday, it should be thoroughly cleaned beforehand to prevent the build up of odours etc. Proceed as described under "Cleaning and heating up for the first time". Leave the door open afterwards.

Warning and Safety instructions

Safety with children

▶ The appliance must be installed at such a height that small children cannot reach the appliance door, which gets hot during use.

▶ Use the safety lock to prevent children operating the appliance or altering the settings.

▶ The appliance is only intended for use by adults who have read these instructions. This appliance is not a toy! To avoid the risk of injury, keep children well away, and do not allow them to play with it or use the controls. They will not understand the potential dangers posed by it. They should be supervised whenever you are working in the kitchen.

▶ The appliance gets hot when in use and remains hot for quite a while after being switched off. To safeguard against burning, keep children well away from the appliance at all times.

▶ Warning: Take care in the area around the door hinge. Danger of injury. Keep children well away.

▶ Packaging, e.g. cling film, polystyrene and plastic wrappings, must be kept out of the reach of babies and young children. Danger of suffocation. Dispose of or recycle all packaging safely as soon as possible.

Protecting the appliance from damage

▶ Do not use the appliance to heat up food in sealed jars and tins. Pressure will build up inside them, and they can explode causing damage to the appliance, as well as the risk of injury and scalding.

▶ Do not store cooked food in the oven. The moisture in the food can lead to corrosion in the appliance.

▶ Do not use metallic containers or utensils in the oven which are likely to rust. This can cause corrosion.

▶ Do not use a steam cleaner to clean this appliance. The steam could reach electrical components and cause a short circuit. Pressurised steam could also cause permanent damage to the surface and to other components, for which the manufacturer cannot accept liability.

▶ The appliance is designed to detect and then self-correct certain operational faults. If a fault is detected, the fault messages **F06** to **F95** will appear in the display. The door of the appliance can only be opened when the fault message is flashing in the display. If the fault message is not flashing, the appliance is still processing the fault. See "Problem solving guide" for further information.

Warning and Safety instructions

Protection from burning and scalding

▶ The appliance, especially the door, becomes extremely hot during use, and remains hot for some time after switching off. Be careful only to touch the door button and door handle when the oven door is hot.

▶ To protect your hands, use heat-resistant pot holders or oven gloves when using the appliance. Do not let them get damp or wet, as this causes heat to transfer through the material more quickly with the risk of scalding or burning yourself.

▶ Pull out the shelf underneath the appliance before opening the door. You can place hot containers on the shelf and it will also collect any drops of hot water.

▶ On no account attempt to force the door open during a programme. The door may only be opened when:

- the cooling down phase is finished,
- the beep has stopped,
- the  symbol is flashing in the time display.

Otherwise there is a danger of burning or scalding.

Attempts to open the door before a programme has run its course will cause an alarm to sound, and the word **door** to appear in the time display.

▶ When putting dishes into the oven or taking them out, take care not to spill the contents. Do not come into contact with hot steam. Danger of scalding.

▶ If bottling, do not use temperatures higher than 95 °C (90 °C if the appliance is installed higher than 1000 m above sea level). Higher temperatures can cause the jars to shatter. Danger of injury.

Warning and Safety instructions

Appliance faults

▶ In the event of damage or a defect, switch off the appliance immediately. Close the stopcock and disconnect from the mains electricity supply. Contact the Service Department. Ensure that current is not supplied to the appliance until after maintenance or repair work has been carried out.

▶ Repairs may only be carried out by a service technician authorised by the manufacturer. Repairs and other work by unqualified persons could be very dangerous and invalidate the guarantee. Never open the housing of the appliance.

▶ In countries where there are areas which may be subject to infestation by cockroaches or other vermin, pay particular attention to keeping the appliance and its surroundings in a clean condition at all times. Any damage which may be caused by cockroaches or other vermin will not be covered by the guarantee.

Futher safety notes

▶ When using an electric socket near the appliance, care should be taken that the cable of the appliance cannot get trapped by the appliance door. The insulation on the cable could become damaged, giving rise to an electric shock hazard.

▶ Always ensure that food is sufficiently cooked or reheated. Many factors will affect the overall cooking time, including the size and amount of food and its temperature. Some foods, e.g. poultry, may contain micro-organisms which are only destroyed by thorough cooking at a sufficiently high temperature for long enough. If in doubt, select a longer cooking or reheating time.

▶ Warning: Take care in the area around the door hinge. Danger of injury.

▶ Do not use plastic containers. These melt at high temperatures.

The manufacturer cannot be held liable for damage caused by non-compliance with these Warning and Safety instructions.

Caring for the environment

Disposal of the packing material

The transport and protective packing has been selected from materials which are environmentally friendly for disposal and can normally be recycled.

Packaging, e.g. cling film, polystyrene and plastic wrappings, must be kept out of the reach of babies and young children. Danger of suffocation.

Dispose of or recycle all packaging materials safely as soon as possible.

Disposal of your old appliance

Electrical and electronic appliances often contain materials which, if handled or disposed of incorrectly, could be potentially hazardous to human health and to the environment. They are, however, essential for the correct functioning of your appliance. Please do not therefore dispose of it with your household waste.

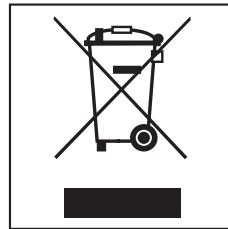

Please dispose of it at your local community waste collection / recycling centre and ensure that it presents no danger to children while being stored for disposal.

It should be unplugged or disconnected from the mains electricity supply by a competent person.

Setting the water hardness level

The steam oven is set at the factory to water hardness range IV (04) .

If your water hardness level differs from this you will need to re-programme the appliance. Proceed as described in "Programming".

You can use the test strip supplied to check the water hardness level, or your local water supplier will be able to advise you on the water hardness of your area.

The water hardness is shown as settings I to IV equivalent to the German scale 1 to >21 °dH (0.2 > 3.8 mmol/l).

Hardness level	Display	Hardness range
I	01	1-7 °dH (0.2 - 1.3 mmol/l)
II	02	8-14 °dH (1.4 - 2.5 mmol/l)
III	03	15-21 °dH (2.7 - 3.8 mmol/l)
IV	04	>21 °dH (above 3.8 mmol/l)

Location

If the steam oven is installed at an altitude higher than 1,000 m above sea level, the boiling point for water will be lower than the boiling point for water at sea level. To cater for this, the boiling point for water in the appliance can be altered. Proceed as described in "Programming".

Before using for the first time

Opening and closing the door

Pull out the shelf underneath the appliance before opening the door. You can place hot containers on the shelf and it will also collect any drops of hot water.

To open the door:

- Using the thumb of your right hand, push the door release forwards and turn the handle upwards until the handle is in a horizontal position.

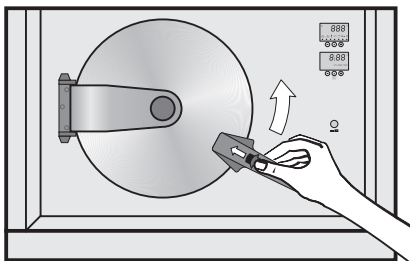

The oven door is now unlocked and can be opened.

Do not attempt to force the door open during a programme. Danger of burning and scalding.

If you attempt to open the door during a programme or before the cooling down phase has finished, an alarm will sound and the word **door** will appear in the time display.

To close the door:

- Turn the handle to the horizontal position. This ensures that the door lugs are lined up with those on the cooking compartment opening (see arrows).

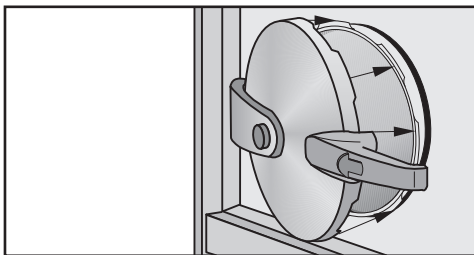

- Using your left hand, press firmly on the door button.
- Using your right hand, turn the handle downwards until you hear it engage. While doing so, also push the door release forwards with your thumb. This vents the cooking compartment and makes it easier to close the door.

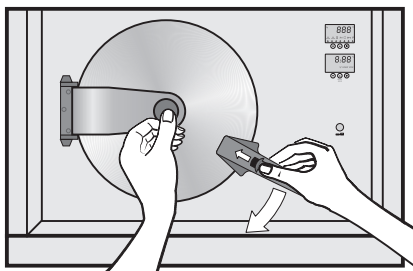

The steam oven cannot be used until the door has been closed properly.

- Push the shelf back in again.

Before using for the first time

Cleaning and heating up for the first time

The appliance and accessories have been treated with a conditioning agent before leaving the factory. Use a solution of hot water with a little washing-up liquid to remove it.

You should then run the 120 °C Steam with pressure SSS programme for 10 minutes to flush out the waterways. Proceed as described in "Operation".

Operation

Before each use

Check that

- the stopcock is open.
- the filter at the bottom of the appliance is correctly positioned to prevent pieces of food blocking the drain.
- the door is properly shut.





The steam oven is then ready for use.

Programming steps in brief

- ❶ Close the steam oven door.
- ❷ Switch the appliance on.
- ❸ Select a programme.
- ❹ Adjust the recommended temperature if required.
- ❺ Set the duration.
- ❻ Start the programme.

These steps are described in more detail on the following pages.

Programme chart

Symbol	Programme	Recommended temperature* in °C	Temperature range which can be set** in °C	
			Factory default setting	Available range
	Steam with pressure	120	105 - 120	101 - 120
	Steam without pressure	100	40 - 100	40 - 100
	Reheat	95	-	-
	Defrost	60	50 - 60	50 - 60

* The recommended temperatures were established by our test kitchen as being the optimum temperatures for the different programmes.

** The recommended temperature can be altered in 5 °C increments within the range quoted. Should you wish to adjust the temperature in 1 °C steps, you will need to alter the factory default setting (see "Programming").

Operation

Switching on and selecting a programme

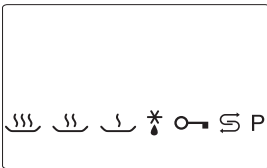

- Close the appliance door.
- Switch the appliance on with the On/Off button.

The following will show in the programme/temperature display:



After a few seconds, the display will change automatically to the Steam with pressure programme 



If you want to use a different programme, press the programme button  repeatedly until the programme you want shows in the display, e.g. Steam without pressure .

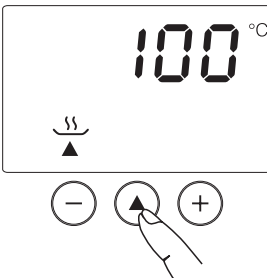

Altering the recommended temperature

The recommended temperature can be altered in 5 °C increments within a certain range. See Programme chart for details. Should you wish to adjust the temperature in 1 °C steps, you will need to alter the factory default setting (see "Programming").

Proceed as follows:

- Use the + or - temperature buttons to set the required temperature.

You can adjust the temperature at any time, even if a programme has already started.

Setting a cooking duration

In the time display, you will see 3 zeros and the flashing \Rightarrow symbol.

- Use the + or - time buttons to set the required duration, e.g. 20 minutes.



A cooking duration of between 1 minute (0:01) and 9 hours 59 minutes (9:59) can be set.

You can adjust the duration at any time, even if a programme has already started.

The charts later in these operating instructions and the cookery book give suggested cooking durations for various types of food. Remember that the cooking duration is not dependent on the amount of food, but on the size of the food. For example, large potatoes will take longer to cook than smaller potatoes.

Starting a programme

A cooking programme can only be started when

- the appliance door is closed.
- a cooking duration has been set.

If the door is not properly shut, an alarm will sound and the word **door** will appear in the time display.

Proceed as follows:

- Press the Start/Stop button ▲.

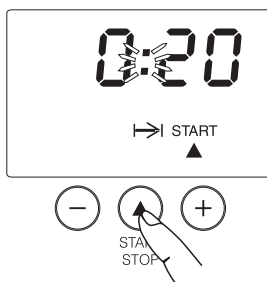

"Start" will appear in the time display, the \Rightarrow symbol will stop flashing, and the colon will begin to flash.

The programme/temperature display will then change to show the actual temperature in the oven as it rises.

Do not be concerned if your appliance makes a noise. As with other appliances that use water, this occurs when the steam generating unit is being filled and when pumping is taking place.

Operation

Interrupting a programme

You can interrupt a programme at any time, for example, to place another container in the cooking compartment.

To interrupt a programme:

- Press the Start/Stop button ▲.

"Stop" will appear in the time display.

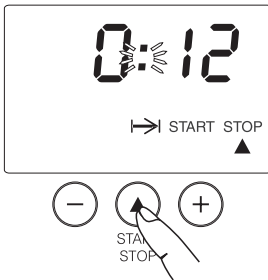

The cooling down phase lasts approx. one minute. The last temperature set will reappear in the programme/temperature display.

- Wait until you hear several beeps, and the \rightarrow symbol is flashing in the time display.



- Pull out the shelf.
- Open the door.

The cooling down phase will begin.

In the time display, the \rightarrow symbol and "Start" will go out, and the colon will stop flashing.

A scrolling bar will appear in the programme/temperature display during the cooling down phase.

To continue the programme:

- Close the door.
- Push the shelf back in again.
- Press the Start/Stop button ▲.

The oven will start heating up again and the display will show the temperature in the cooking compartment rising.

Do not attempt to force the door open during a programme. Danger of burning and scalding. Keep children away.

The door may only be opened when:

- the cooling down phase is finished
- the beep has stopped
- the  symbol in the time display is flashing.

If you attempt to open the door during a programme or before the cooling down phase has finished, an alarm will sound and the word **door** will appear in the time display.

When removing dishes from the oven, be careful not to spill the contents.

Changing a programme

- Press the Start/Stop button ▲.
- Wait until the cooling down phase has been completed.
- Select the programme required and proceed as before.

Operation

At the end of the cooking duration

There is a cooling down phase at the end of the cooking duration.

"Stop" will appear in the time display. The \rightarrow symbol and "Start" will go out, and the colon will stop flashing.



A scrolling bar will appear in the programme/temperature display during the cooling down phase.

The cooling down phase lasts approx. one minute. It may last longer than this when cooking larger quantities.

- Wait until you hear several beeps, 3 zeros appear in the time display, and the \rightarrow symbol flashes.



- Pull out the shelf.
- Open the door.
- Switch off the appliance.

The appliance will now drain. Three horizontal lines - - - will appear in the programme/temperature display. Then °C will appear in the display for as long as the temperature remains over 45 °C. Please note that the appliance does not switch off until the °C symbol has gone out.

Take care. The cooking compartment and door may still be hot even after the cooling down phase. When removing dishes from the oven, use dry oven gloves.

Be careful not to spill any of the contents.

After use

- As soon as the °C in the programme/temperature display goes out, wipe the oven out with a solution of warm water and washing-up liquid or vinegar. Then dry it with a cloth.
- Leave the door open to allow the compartment to dry out thoroughly.
- Close the stopcock to avoid any risk of water damage.
- Push the shelf back in again.

Practical tips

Suitable containers

Some stainless steel cooking containers are supplied with the appliance.

Other containers, in a variety of sizes, both perforated and solid, are available as optional extras (see "Optional accessories").





When choosing the most suitable container for the particular food you are cooking, please note:

- Use perforated cooking containers whenever possible so long as the food is suitable, e.g. for vegetables. The steam can reach the food from all sides and the food is cooked evenly.
- With large items of food, such as whole potatoes, the steam can work more effectively because there are spaces between the individual pieces into which the steam can penetrate. This way a large quantity will take the same time to cook as a smaller amount and large, deep containers can be used. Where possible, space the food out to allow the steam more room.
- More compact dishes such as casseroles or bakes, or food such as peas or asparagus spears, which have little or no space between them will take longer to cook because the steam has less space to work in. The fuller the container, the longer it will take to cook. It is best to use 2 or 3 flat containers rather than one deep one for these types of foods, and then fill them only 3 - 5 cm deep. Cooking durations quoted are calculated on this principle. Deeper dishes will take longer to cook.

Heat-resistant glass, ceramic, porcelain, stainless steel and enamel dishes are all suitable. Important:







- The container must be heat resistant to 120 °C.
- Food will take considerably longer to cook than the time quoted if the dish has thick sides.
- Place the dish on the tray supplied.
- Ensure that the dish does not touch the walls of the cooking compartment so that steam can reach the food from all sides.

Steaming

Food	Programme	Temperature in °C	Duration in minutes
Vegetables			
Beans, green	 Steam with pressure	120	3 - 5
Brussels sprouts	"	120	6 - 8
Cabbage, red or green, chopped	"	120	4 - 6
Cauliflower, florets	"	120	3 - 5
Kohlrabi, batons	"	120	3 - 5
Leeks, sliced	"	120	2 - 3
Potatoes, in their skins	"	120	12 - 14
Potatoes, peeled and quartered	"	120	6 - 8
Sliced carrots	"	120	3 - 4
Broccoli, florets	 Steam without pressure	100	4 - 6
Asparagus	"	100	8 - 10
Peas	"	100	3 - 5
Zucchini	"	100	2 - 4
Meat			
Beef goulash	 Steam with pressure	120	20 - 25
Pork cutlets	"	120	3 - 4
Chicken breast	 Steam without pressure	100	6 - 8
Turkey roulade	"	100	12 - 15
Fish and shellfish			
Cod, steaks	 Steam without pressure	100	4 - 8
Monkfish	"	85*	8 - 10
Mussels	"	90*	10 - 12
Plaice	"	85*	8 - 10
Salmon, fillet	"	100	4 - 6
Sea trout	"	100	12 - 14
Trout, whole	"	100	10 - 12
Tuna steak	"	100	3 - 4

* This temperature is not the same as the recommended temperature.



Practical tips

Food	Programme	Temperature in °C	Duration in minutes
Pulses			
Brown lentils	 Steam with pressure	120	8 - 10
Dried peas (pre-soaked)	"	120	10 - 15
Kidney beans (pre-soaked)	"	120	10 - 15
Rice			
Cracked wheat	 Steam with pressure	120	5
Pearl barley	"	120	8 - 15
Brown rice	 Steam without pressure	100	35
White rice	"	100	20 - 25
Wild rice	"	100	30 - 35
Eggs			
Soft boiled	 Steam without pressure	100	3 - 4
Medium boiled	"	100	5 - 6
Hard boiled	"	100	8 - 10
Fruit			
Apples/Pears, in pieces	 Steam without pressure	100	3 - 5
Cherries	"	100	2 - 4
Gooseberries	"	100	2 - 4
Plums	"	100	2 - 4
Rhubarb	"	100	2 - 4
Desserts			
Flummery	 Steam without pressure	100	10 - 12
Soufflé, portions	"	90*	15 - 20
Sweet dumplings	"	100	12 - 15



* This temperature is not the same as the recommended temperature.

Tips on steaming

We recommend using:

- Steam with pressure , 120 °C for rapidly cooking robust foods.
- Steam without pressure , 100 °C for gently cooking delicate foods.
- You can select any shelf level. You can also cook on several levels at the same time. This will not alter the cooking duration.
- When cooking frozen food, e.g. vegetables, ensure that any large clumps frozen together are broken up first so that they cook evenly. The cooking duration is approximately the same as for fresh vegetables.
- Frozen and fresh vegetables which take the same length of time to cook can be cooked together.
- Frozen fish should be partially defrosted before cooking. We recommend using the "Defrost" function (see "Defrosting" for more information).
- Cooking with steam retains the true taste of the food better than conventional cooking. Therefore food should not be seasoned until after it has been cooked.
- Only fill solid containers $\frac{3}{4}$ full with liquid.
- Soak pulses and grains in cold water before cooking. Pulses and grains swell during cooking and so need to be cooked in liquid. The ratio of pre-soaked pulses and grains to water is 1:1.
- Rice also swells when cooked and should be cooked in liquid. The proportion of food to liquid will vary depending on the type of rice and how it has been pre-treated. With parboiled rice, basmati rice and wild rice, the proportion of food to liquid should be 1:1, with brown rice 1:1.5 and risotto rice 1:2.
- Dry pasta and noodles should be well covered with liquid. Reduce the cooking time recommended on the packaging by about $\frac{1}{3}$ as the pasta will start to swell during the heating up time.
- Cooking liquids do not boil away. They are either absorbed by the food, as with rice and pasta, or they remain in the dish as with casseroles. The liquid can then be used for making a sauce, e.g. by adding crème fraîche.

Practical tips

- You can thicken sauces in the steam oven by adding flour and butter to liquid (40 g flour and 40 g butter to 0.5 litres liquid).
- Grease perforated containers beforehand if used for cooking fish, and solid containers if used for cooking dishes containing eggs.
- When cooking meat **without adding any additional liquid** to the container, the meat juices can be used to for making gravy and sauces. Put the meat and other ingredients, e.g. vegetables, in a perforated container. Place a solid container underneath to catch the juice.
- If you wish to **add additional liquid** when cooking meat using Steam with pressure , it is very important not to add too much liquid as this can cause the container to boil over. If necessary add liquid, e.g. stock, after cooking.
- When using Steam with pressure , cooking will only take approx. half the time it would take with conventional cooking.
- With the Steam with pressure , 120 °C programme, during the cooling down phase air will be circulated around the cooking compartment. This air can dislodge food from the cooking container and soil the cooking compartment. This mostly occurs when food is being cooked in liquid (soup, casseroles etc) and also when the food has a pulpy consistency, e.g. apple sauce.

When cooking these types of food, cover the cooking container with the tray or lid (see "Optional accessories"). Place the covered cooking container between the two runners of the shelf level; do not place it on top of the upper runner.
- When cooking fish or food with a distinctive colour (e.g. spinach) in a perforated container, place the container on the lowest shelf level to avoid any transfer of tastes or colour to other food.
- Yeast dough can be put in the oven to prove. Select Steam without pressure , and reduce the recommended temperature to 40 °C. Cover the dough.

Reheating

 Reheat	
Food to be reheated	Duration in minutes
Vegetables	
Cauliflower, runner beans	2
Carrots, kohlrabi	2
Side dishes	
Dumplings, potatoes (halved)	3 - 4
Pasta, rice	2 - 3
Meat and poultry	
Sliced meat 1.5 cm thick	3 - 5
Stew	3 - 5
Chicken schnitzel	3 - 5
Meatballs in sauce	3 - 5
Sliced roulade	3 - 5
Fish	
Fish fillet	2 - 3
Fish roulade, halved	2 - 3
Plated meals	
Chicken fricassee with rice	3 - 5
Roast pork with potatoes and vegetables	3 - 4
Spaghetti with tomato sauce	2 - 3
Soups/casseroles	
Casseroles	4 - 5
Soup	2 - 3

The Reheat programme  is very effective at reheating food which has been prepared previously. The dish will heat up as well. Because the appliance does not use water to cool down, condensation does not build up in the appliance or on the food.

Proceed as follows:

- Place the food on a plate.
- Then place the plate on the tray and push it into the oven.
- Select the Reheat programme .
- Set the duration (see chart).
- Press the Start/Stop button.

Practical tips

Defrosting

* Defrost				
Food to be defrosted	Weight in g	Temperature in °C	Defrosting duration in minutes	Standing time in minutes
Meat				
Stew	500	60	30 - 40	10 - 15
Minced meat	250	50*	15 - 20	10 - 15
Cutlets, chops, sausages	800	60	25 - 35	15 - 20
Poultry				
Chicken	1000	60	40	15 - 20
Chicken drumsticks	150	60	20 - 25	10 - 15
Chicken schnitzel	500	60	25 - 30	10 - 15
Fish, seafood				
Fish fillets	400	60	15	10 - 15
Prawns	300	60	4 - 6	5
Vegetables				
Frozen in a block	300	60	20 - 25	10 - 15
Frozen in small portions	350	60	15	8 - 10
Fruit				
Apple sauce/stewed apples	250	60	20 - 25	10 - 15
Strawberries/raspberries	300	60	8 - 10	10 - 12
Dairy products				
Cheese	100	60	15	10 - 15
Cream	250	60	20 - 25	10 - 15
Baking				
Puff pastries	-	60	10 - 12	10 - 15
Yeast buns	-	60	10 - 12	10 - 15
 Steam without pressure				
Bread	250	100	10 - 15	10 - 15
Bread rolls	-	100	6 - 7	1 - 2

* This temperature is not the same as the recommended temperature.

Frozen food can be defrosted in this appliance in much less time than when defrosting at room temperature.

- Place the food to be defrosted in the appliance.
- Select the Defrost programme ❄.
- Change the pre-set recommended temperature if necessary (see chart) .
- Set the duration (see chart).
- Press the Start/Stop button.

Tips on defrosting

- All meat and poultry should be fully defrosted before cooking. When defrosting meat or poultry, place the food in a perforated container and place the solid container underneath to catch the defrosted liquid, so that the meat is not lying in this liquid. It is particularly important to observe food hygiene rules when defrosting poultry. Do not use the liquid from defrosted poultry. Pour it away and wash the tray, the sink and your hands.
Danger of salmonella!
- Food which will not drip can be placed in a perforated container once the wrapping has been removed.
- Fish does not need to be fully defrosted before cooking. Defrost so that the surface is sufficiently thawed to take herbs and seasoning. Depending on the thickness of the fish, 2-3 minutes should be enough.
- When defrosting food which has frozen together, e.g. berries, chops, fish fillets etc separate or break it up about half-way through the defrosting time.
- Allow food to stand at room temperature at the end of defrosting. This standing time (see chart) is necessary to ensure that the food is fully defrosted right through to the core.
- Do not refreeze food once it has thawed.
- Defrost frozen pre-cooked meals according to the manufacturer's instructions.
- Defrost baked goods in a sealed freezer bag.

Practical tips

Cooking whole meals

It is very economical and practical to cook a whole meal at the same time in the steam oven.

In general, cooking durations will vary according to the type of food. This means that you will need to open the steam oven at different times to add a particular dish. Our test kitchen recommends the following procedure, as shown in this example using Steam with pressure :

Lamb stew	8 minutes
Potatoes	8 minutes
Carrots	4 minutes

Proceed as follows:

- First place the food with the longest cooking duration (the lamb stew and the potatoes) in the steam oven.
- Select Steam with pressure  120 °C.
- Calculate the initial cooking duration by subtracting the duration for the carrots from the duration for lamb stew / potatoes, i.e. 8 minutes less 4 minutes = 4 minutes.
- Set a duration of 4 minutes and press the Start/Stop button.
- Once the 4 minutes and also the cooling down phase has elapsed, place the second dish (carrots) in the oven.
- Set the cooking duration for the second dish, i. e. 4 minutes.
- Press the Start/Stop button.

At the end of the cooking duration you can remove all three dishes at the same time.

Blanching

You can use your steam oven to blanch vegetables and fruit for freezing.

- Put the prepared fruit or vegetables into a perforated container and place it in the oven.
- Select Steam without pressure  100 °C.
- Set a time of 1-2 minutes.
- Press the Start/Stop button.
- Once blanched, plunge the vegetables/fruit into ice cold water to cool them down quickly. Drain them well.

The vegetables/fruit can now be frozen.

Bottling

When bottling, do not use temperatures higher than 95 °C (or 90 °C if the appliance is installed at altitudes higher than 1000 m above sea level). Higher temperatures can cause the jars to shatter. Danger of injury.

Select Steam without pressure  for bottling.

 Steam without pressure		
Produce	Temp. in °C	Duration in minutes**
Fruit		
Apples	90*	50
Apple sauce/stewed apples	90*	65
Red / Blackcurrants	80*	50
Gooseberries	80*	55
Fruit with stones	85*	55
Vegetables		
Beans	95*	120
Gherkins	90*	55

* This temperature is not the same as the recommended temperature.

** The times quoted are for 1.0 litre jars. If using 0.5 litre jars reduce the duration by about 15 minutes. If using 0.25 litre jars reduce the duration by about 20 minutes.

Proceed as follows:

- Place the prepared jars (all the same size) in a perforated container, ensuring that they do not touch one another.

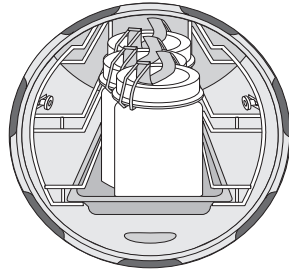

- Select Steam without pressure  100 °C.
- Change the recommended temperature if necessary (see chart) .
- Set the duration (see chart).
- Press the Start/Stop button.
- Make use of residual heat by leaving the jars in the oven for 30 minutes after it has switched off.
- Cover the jars with a cloth and allow to cool for approx. 24 hours.

Practical tips

Extracting juice with steam

You can use the Steam with pressure  programme to extract juice from fruit and vegetables. It is best to use very ripe fruit, as the riper the fruit the greater the quantity of juice produced. Very ripe fruit will also produce a more intense flavour.

 Steam with pressure	
Food to be juiced	Duration in minutes
Soft fruit, e.g. berries	20 - 35
Medium hard fruit, e.g. apples, pears	30 - 45
Hard fruit e.g. rhubarb, quinces	40 - 50

Proceed as follows:

- Put the prepared fruit or vegetables into a perforated container and place it in the steam oven.
- Place a solid container underneath to catch the juice.
- Select Steam with pressure  120 °C.
- Set the duration (see chart).
- Press the Start/Stop button.

Useful tips

- Wash the fruit or vegetables to be juiced and cut away any bruised or damaged parts.
- There is no need to remove pips from fruit.
- Remove the stalks from grapes and morello cherries as these are bitter. The stalks do not need to be removed from strawberries, raspberries etc.
- Dice large fruit such as apples into 2 cm thick cubes. The firmer the fruit or vegetables, the smaller it should be diced.
- Try experimenting with mild and tart flavours, for example, mix apples with elderberries.
- Adding sugar will increase the quantity of juice produced and improve the flavour. Sprinkle the fruit with sugar and leave to soak in for a few hours before juicing. For sweet fruit add 100 - 150 g of sugar and more tart fruit, 150 - 200 g of sugar.
- Adding herbs will produce a more intensely flavoured vegetable juice.
- If you wish to bottle the juice rather than consume it straight away, pour it whilst hot into hot, sterilised bottles up to the rim and then seal immediately with sterilised rubber tops.

Disinfecting containers

The steam oven will disinfect baby bottles and other containers so that at the end of the programme they are as germ free as they would have been had they been boiled. Check beforehand that all parts, teats etc. are declared by the manufacturer to be heat resistant to 100 °C and also that they can withstand hot steam.

- Dismantle, clean and thoroughly rinse baby bottles. Place the individual parts in a perforated cooking container, ensuring that they do not touch one another. Cover the cooking container with the tray or the lid.
- Select Steam without pressure  100 °C.
- Set and confirm a duration of 15 minutes.

All parts of the bottles must be completely dry before they are reassembled to keep them germ free.

Preparing yoghurt

- To prepare yoghurt you will need 100 g yoghurt (with live culture) and 1 litre of milk. The yoghurt and milk should have the same percentage fat content.

You can either use unchilled long-life milk or fresh milk. Fresh milk will, however, give a better set. If using fresh milk it should first be heated up to 90°C (do not boil it), and then left to cool.

- Mix the yoghurt and the milk together and then pour the mixture into 6 or 7 portion sized glass jars or special yoghurt jars. Seal the jars.
- Place the jars in a perforated container, ensuring that they do not touch one another.
- Select Steam without pressure  and reduce the recommended temperature to 40 °C.
- Set a duration of 5 hours.

Allow the yoghurt to cool and then place in the refrigerator. It will not achieve its maximum set until it has been thoroughly chilled.

Safety features

Normally, steam pressure and temperature will be regulated automatically by the appliance. However, if a fault should occur, the appliance is fitted with an overheating protection device which protects against the temperature rising too high.

The safety valve should be replaced every 1-2 years, depending upon frequency of use.

Safety devices must not be altered or tampered with.

Pressure release / Safety valve

The safety valve and the pressure release can operate individually, simultaneously or one after the other.

If they are triggered, steam will be released through the openings above and below the door hinge.

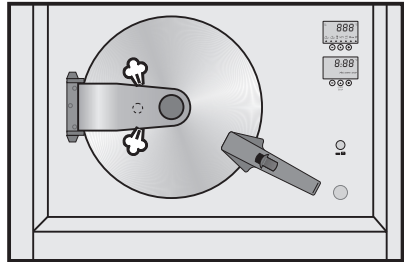

- Press the Start/Stop button.
- Wait until the cooling down phase has been completed (see "Interrupting a programme").
- Pull out the shelf.
- Open the door.

Safety features

- The **pressure release** mechanism contains a small silicone washer which rests in a holder. First check if this washer has been forced out of its holder. If this has happened, fit a new washer into the holder inside the appliance door (see "Accessories supplied").

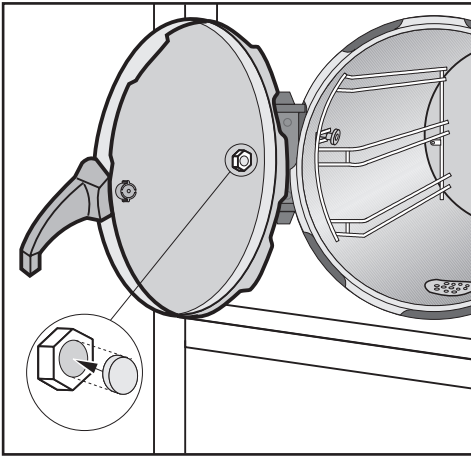

The steam oven can now be used again in the normal way.

- If the pressure release mechanism has not been activated (i.e. the silicone washer is still in its holder), remove the **safety valve** from the inside of the appliance door.
- Press the metal pin of the safety valve back in.

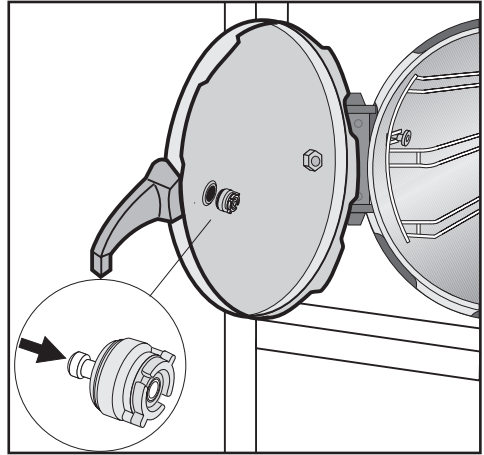

- Insert the safety valve back into the inside of the door. Make sure that the seal fits correctly.

The steam oven can now be used again in the normal way.

If the pressure release mechanism or the safety valve trips again, contact the Service department.

Safety features

Overheating protection

The overheating protection device is located on the right-hand side of the appliance underneath the On/Off button. This switches the heating off automatically if the temperature in the steam generator gets too high. **F27** will appear in the programme/temperature display and the cooling down phase will begin.

The cooling down phase will be completed in approx. 1 minute and several beeps will sound. **F27** will flash in the programme/temperature display for a short while and then three horizontal bars - - - will appear. After a while **F20** will appear in the display.

Proceed as follows:

- Switch the appliance off and open the door.
- Allow the appliance to cool down for approx. 30 minutes.

F20 will disappear from the display during this time.

- Remove the overheating protection device cover cap (see arrow). Use a screwdriver or similar to press the button underneath in again.

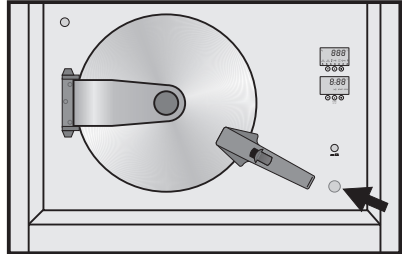

- Replace the cover cap.

The steam oven can now be used again in the normal way.

If the overheating protection device trips again, contact the Service department.

Safety lock

The appliance is equipped with a safety lock which can be used to prevent it from being switched on by accident and also to prevent certain settings from being altered when the steam oven is operating.

If you wish to use the safety lock you will need to alter the setting (see "Programming").

If the lock is activated **while the steam oven is ready for use but not operating**, you will be able to switch the appliance on and off but not operate it.

If the safety lock is activated **when the oven is in operation** then the appliance can **only be used as follows**:

- The recommended temperature can be decreased but not increased.
- The duration which has been set can only be shortened.
- The steam oven can be switched off and back on again but a programme cannot be selected.

To activate the safety lock:

- Press the programme button ▲ repeatedly until 3 bars and the lock symbol  appear in the programme/temperature display.

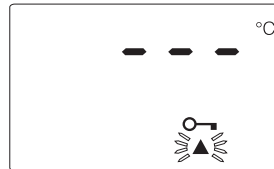

- Press the + temperature button.



Now if you attempt to enter a setting, "0-0" will appear in the programme/temperature display to show that the safety lock is activated.

To deactivate the safety lock:

- Press the programme button ▲ repeatedly until 0-0 and the  symbol appear in the display.
- Press the - temperature button.

The lock is now deactivated.

Cleaning and care

General notes

Before cleaning disconnect the appliance from the electricity supply and allow it to cool down to a safe temperature.

Clean the whole appliance and then dry it thoroughly after each use.

Make sure the appliance is completely dry before closing the door.

Do not use a steam cleaner to clean the appliance.

The steam could reach electrical components and cause a short circuit.

Do not use commercial cleaning agents. Only use agents designed for domestic use.

Do not use cleaning agents or washing-up liquids containing aliphatics as these could cause the seals to swell.

Appliance front

Remove any soiling immediately. If not, it might become impossible to remove and could cause the surface to alter or discolour.

Clean the front using a Miele microfibre E-cloth or with a clean sponge and a solution of hot water and washing-up liquid. After cleaning dry with a soft cloth.

The external surfaces of this appliance are all susceptible to scratching. Scratches on glass surfaces could even cause a breakage.

Contact with unsuitable cleaning agents can alter or discolour the outer surfaces.

To avoid damaging the surface of your appliance, do not use:

- cleaning agents containing soda, ammonia, acids or chlorides,
- cleaning agents containing descaling agents,
- abrasive cleaning agents, e.g. powder cleaners and cream cleaners,
- solvent-based cleaning agents,
- stainless steel cleaning agents,
- dishwasher cleaner,
- oven sprays,
- glass cleaning agents,
- hard, abrasive sponges and brushes, e.g. pot scourers,
- sharp metal scrapers.

Cooking containers and drain filter

The cooking containers and drain filter should be washed and dried each time they are used.

Soak any stubborn soiling first before removing with a soft brush.

They are all dishwasher safe.

Door seal

Clean and dry the door seal by hand after each use using a mild solution of hot water with a little washing-up liquid applied with a damp cloth. Do not clean the seal in a dishwasher. Wipe dry using a soft cloth.

The door seal should be replaced every 1-2 years, depending upon frequency of use.

Safety valve

The safety valve should be replaced every 1-2 years, depending upon frequency of use.

- Open the door.
- Remove the old safety valve from the inside of the door.
- Fit the new safety valve. Make sure that the seal fits correctly.

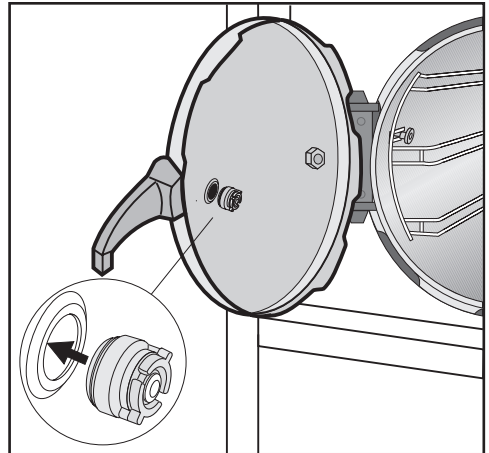

Cleaning and care

Cooking compartment and pull-out shelf

The cooking compartment, the inside of the appliance door and the pull-out shelf should be cleaned and dried after each use. Allow the appliance to cool down to a safe temperature before cleaning.

Most cooking residues can be removed easily with a damp cloth and a mild solution of hot water and washing-up liquid.

In areas where the water is very hard, a white deposit can build up on interior walls. This can be removed with a little vinegar on a damp cloth.

If the water supply in your area is very hard, discolouration can occur on the oven interior walls after prolonged use of the appliance. These can be removed using a proprietary citric acid based descaling agent or with a cleaning agent designed for use on ceramic hobs and stainless steel. These can be obtained from a good retailer.

Wipe the cooking compartment and the pull-out shelf with clean water, and then rub dry.

If necessary, the pull-out shelf can be removed completely for cleaning.

To remove the pull-out shelf:

- Pull the shelf out as far as possible.
- Unscrew the two thumb nuts ①.
- Take the pull-out shelf off its runners and then clean and dry it.

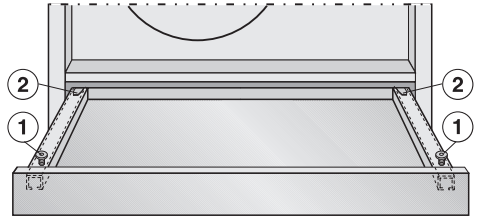

To replace the pull-out shelf:

- Pull the two shelf runners out as far as possible.
- Push the shelf under the two holders ②, located at the back of the runners.
- Place the shelf on the two screws at the front of the runners.
- Then tighten the thumb nuts.

Shelf runners

It is helpful to remove the shelf runners when you wish to give the oven a thorough clean.

To remove the runners:

- Loosen fixing screws ①, and the runners can then be removed quite easily by pulling them towards you.

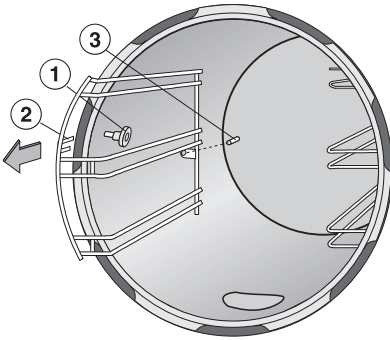

- Clean the runners with a solution of washing-up liquid or in the dishwasher.

To replace the runners:

- After cleaning, re-fit the runners by placing the runner with the guide ② (at the front of the middle runner) onto the loosened fixing screw.
- Insert the eyelet, located at the rear of the middle runner, on to the protruding pin ③ in the rear wall of the cooking compartment.
- Tighten the screws again.

Cleaning and care

Water nozzle

During the cooling down phase, water is sprayed into the cooking compartment from a water nozzle which is located behind the deflector plate at the back of the runners on the right hand side. With prolonged use, this nozzle can become dirty and will require descaling.

The nozzle must be descaled if the fault message **F13** appears in the display.

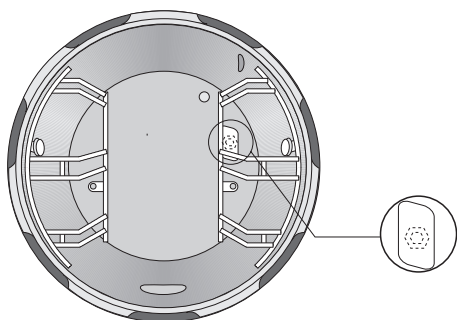

- Wait until several beeps sound. Now open the door and remove the food which is cooking.

Take care as a large amount of extremely hot steam may escape when the door is opened. The food will also be very hot.

- Leave the appliance to cool down with the door open.
- Remove the runners on the right-hand side (see "Shelf runners")
- Pull out the nozzle.

- Descaling the nozzle using the descaling agent supplied with the appliance or with a suitable proprietary descaling agent following the instructions on the packaging.

After descaling rinse the nozzle under fresh running water.

Before replacing the nozzle, all parts of the appliance which carry water must be flushed through.

- Close the door and switch the appliance on. Select Steam without pressure **SS**.
- Set a duration of 1 minute, and press the Start/Stop button.
- Wait until the cooling down phase has been completed (see "At the end of the cooking duration").
- Then open the door and replace the water nozzle and the shelf runners.

The steam oven can now be used again in the normal way.

If the fault message **F13** reappears after the nozzle has been descaled, contact the Service Department.

Descaling

 To prevent the risk of damage only use the descaling agent supplied with the appliance (see "Accessories supplied").



Descaling must be carried out on a cold appliance to prevent harmful vapours forming.

The descaling agent is caustic.

Avoid contact with the skin and do not inhale the vapours.

If you do come into contact with descaling agent it should be rinsed off immediately with plenty of fresh water. In the event of an adverse reaction or if it has been inhaled or ingested, seek medical help. Replace the lid securely after use and keep out of the reach of children.

Do not spill descaling agent on metal surfaces. This could cause marks. Any spillages should be wiped away immediately.

The appliance will alert you after a certain number of operating hours that the steam generator needs to be descaled. When the appliance is switched on the  symbol, the Descale programme symbol  and the number **10** will appear in the programme/temperature display.

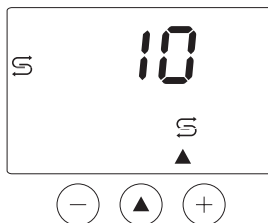

The number indicates that the appliance can be used a further 10 times before it locks out. If the appliance is not descaled immediately, a  will appear in the display the next time the appliance is switched on, and so on.

The appliance will then lock and it must be descaled before it can be used again. We recommend that you descale the appliance before it locks out.

The descaling process can only be stopped by switching off the appliance. If the appliance is switched back on, after interrupting it, a rinse cycle will be carried out automatically (see "Problem solving guide").

Cleaning and care

Proceed as follows:

- Wait until the appliance has cooled down.
- Press the nozzle out of the plunger on the syringe supplied and attach it to the spout of the syringe as shown.

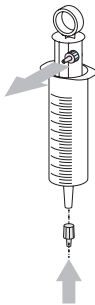

- Close the door and switch on the empty appliance.

The **S** symbol, the Descal programme symbol **S** and a number will appear in the programme/temperature display.

- Press the Start/Stop button.

E00 will appear in the programme/temperature display, the **S** symbol will appear on the left hand side and the Descal programme symbol **S** will also appear.

The appliance will start to drain. Once the draining process is complete, **E01** will appear in the programme/temperature display.

- Fill the syringe with water. Press the nozzle into the opening on the top left of the front of the appliance (see arrow) and inject 1 syringe of water slowly and evenly. Make sure you keep the nozzle horizontal.

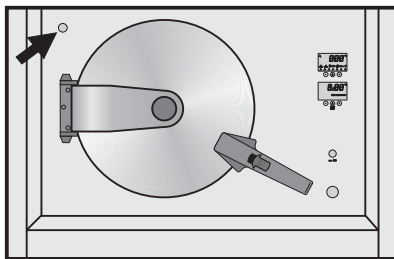

- Pour 300 ml of the descaling agent supplied into a suitable acid-proof, e.g. glass or china, container.
- Now fill the syringe with descaling agent from the container, and inject the contents of 1 syringe into the opening.
- Then fill the syringe with water and inject the water into the opening. This needs to be done twice.

You will then hear a beep and **E02** will appear in the programme/temperature display. The machine is preparing itself for the descaling procedure.

If you do not hear the beep, do not inject any more water into the system. Wait for five minutes. If the beep still does not sound you should switch the machine off and then back on again (see "Problem solving guide").

When the appliance is ready to begin the descaling process, a beep will sound and **ED3** will appear in the programme/temperature display.

- Now fill the syringe with descaling agent from the container, and inject the contents of 2 syringes into the opening.
- Then fill the syringe with water and inject the water into the opening. This needs to be done twice.

You will then hear a beep and **ED4** will appear in the programme/temperature display. A descaling duration of 30 minutes will appear in the time display. This time cannot be altered.

The descaling process will now begin. A beep will sound when the descaling process reaches the draining and rinsing stages and **ED5** to **ED7** will appear in the display.

When the descaling process has finished a beep will sound and **ED8** will appear in the programme/temperature display. 3 zeros and a flashing **→** symbol will appear in the time display.

After descaling:

- Pull out the shelf.
- Open the door.
- Switch off the appliance.
- Wipe out the cooking compartment with a mild solution of hot water and washing-up liquid or a little vinegar and water and then dry it with a cloth.
- Dry the descaling agent opening to avoid a build-up of encrustations.
- Leave the door open to allow the compartment to dry out thoroughly.
- Close the stopcock to avoid any risk of water damage.
- Push the shelf back in again.

If there is any descaling agent left in the container, use the syringe to put it back into the bottle.

Wash the container thoroughly.

Programming

Programme option*	Status**	Setting
P 1 Buzzer volume	S 00	Very quiet
	S 01	Quiet
	S 02	Medium
	S 03	Loud
P 2 Audible tone at end of programme	S 00	Single beep
	S 01	Beeps for a short time
	S 02	Beeps for 5 minutes
P 3 Safety lock	S 00	Not possible
	S 01	Possible
P 4 Programme in display after switching on	S 00	Steam with pressure
	S 01	Steam without pressure
	S 02	Reheat
	S 03	Defrost
	S 04	Last programme selected
P 5 Water hardness	S 01	Soft
	S 02	Medium
	S 03	Hard
	S 04	Very hard
P 6 Location (altitude)	S 00	Below 1000 m
	S 01	Above 1000 m
P 7 Altering the temperature	S 00	In 5° increments
	S 01	In 1° increments (note that when warming up, the temperature of the appliance will continue to be shown in 5° increments)
P 8 Demonstration mode and factory default settings	S 00	Demonstration mode on
	S 01	Demonstration mode off
	S 09	Factory default settings reinstated

* Programmes not shown here have no allocation.

** The factory default settings are shown in bold.

You can change the default settings of the programme options (see chart).

The appliance can now be switched off or used as required.

Proceed as follows:

- Use the programme button ▲ to select programme P.



- Press the + temperature button repeatedly until the programme option you want appears in the programme/temperature display (1 for P1, 2 for P2, etc).
- Press the + or - time button repeatedly until the status you want appears in the time display, e.g. 02.

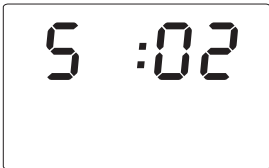

- Press the programme button ▲.

The setting you have selected is now stored in the memory.

Problem solving guide

Installation work and repairs to electrical components of this appliance must only be carried out by a suitably qualified and competent person in strict accordance with current local and national safety regulations. Repairs and other work by unqualified persons could be dangerous. The manufacturer cannot be held liable for unauthorised work.

... the appliance is locked during a prolonged power cut and you want to remove the food from it.

Caution: the appliance will still be hot and under pressure.

Pull out the shelf. Then using the thumb of your right hand, push the door release forwards **slowly a little bit at a time**.

Caution! Steam will escape from above and below the door hinge.

Open the door very carefully. Danger of scalding with hot steam.

What to do if, ...

... the appliance beeps after the start of a programme, and the word "door" appears in the time display.

The door has not been closed properly.

... the mains fuse has tripped.

Reset the trip switch in the mains fuse box, and switch the appliance back on. If it still cannot be operated, contact a qualified electrician or the Miele Service Department.



... the appliance does not heat up.

Check whether the Demonstation mode has been set (see "Programming").

... steam suddenly escapes from the appliance door.

Check whether

- the safety valve has tripped. Proceed as described in "Pressure release / Safety valve".
- the pressure release has tripped. Proceed as described in "Pressure release / Safety valve".
- the rubber door seal is not fitting correctly or is damaged, e.g. cracks are visible. Fit the seal correctly or, if necessary, replace it.

... After switching on, the descaling programme symbol  and  appear in the programme/temperature display, the  symbol also appears on the left of the display, and the appliance beeps.

The appliance needs to be descaled. Proceed as described in "Descaling" in "Cleaning and care".

...  and *E04* appear in the programme/temperature display and *0:05* appears in the time display.

The descaling process was interrupted by a power cut or by being inadvertently switched off.

The appliance will automatically carry out a rinsing programme after being switched on again to flush out any descaling fluid. This process cannot be aborted. Wait until you hear several beeps, and the  symbol is flashing in the time display. Now you can either re-start the descaling process, or select another programme.

... the following fault messages appear in the programme/temperature display.

For all fault messages:

The door can only be opened when:

- the fault message is flashing alternately with the set temperature,
- the  symbol is flashing in the time display,
- the alarm has stopped.

If the display is not flashing, the appliance is still processing the fault.

F06 The temperature thermostat is faulty.

Switch the appliance off and call the Service Department.

F12  Water is not getting into the appliance.

Check whether

- the stopcock is open. If necessary open it and start the programme again.
- the water inlet hose is faulty.
- the filter in the water inlet is blocked.

If you cannot remedy the fault yourself, switch the appliance off and call a plumber or the Service Department.

Problem solving guide

F13 The temperature in the cooking compartment is too high.

The appliance has not cooled down sufficiently during the cooling down phase.

Check whether

- the water stopcock is open. If necessary open it and start the programme again.
- the water nozzle on the rear wall of the cooking compartment needs descaling. Proceed as described in "Water nozzle" in "Cleaning and care".

If neither of the above is the problem, it could be that the quantity of food being cooked was too high. Very large quantities of food, e.g. potatoes, will affect the cooling down of the appliance.

F14  Too little water is running into the steam generator.

Switch the appliance off and then back on again. If the fault message appears again, switch the appliance off and call the Service department.

F20 The overheating protection mechanism has been activated.

Proceed as described in "Overheating protection".

F27 The power supply was interrupted while a programme was running.

Check the cooking status and if necessary, set a new cooking duration and then press the Start/Stop button to start the programme again.

F40 The electronics are carrying out a self test.

F83 The temperature regulator is faulty and the temperature in the cooking compartment has risen above 125 °C.

The programme will be interrupted and the cooling down phase will begin.

Switch the appliance off after the cooling down phase and call the Service Department.

F94 The water inlet valve is not providing a tight seal.

Switch the appliance off, turn off the water supply at the stopcock and call the Service Department.

F95 A defect has occurred within the system which carries water in the appliance.

Wait until **F95** flashes alternately with the set temperature in the display. Press the Start/Stop button.

If **F95** appears repeatedly, switch the appliance off, turn off the stopcock and call the Service Department.

Technical data

Total connected load: see data plate

Plumbing

The steam oven needs to be connected to the mains water supply and to the drainage system by a fully qualified person in accordance with national and local safety regulations.

The machine is constructed to comply with German water regulations (DVGW), and may be connected to a suitable supply without an extra non-return valve if national regulations permit.

The plumbing installation must be made in such a way that the stopcock is easily accessible after the appliance has been built in.

The installer is responsible for ensuring that the appliance functions correctly when installed.

The manufacturer cannot accept liability for damage which is a direct or indirect result of incorrect installation or connection.

Important

Refer to the steam oven installation booklet for more information.

Electrical connection

See Installation Instruction Booklet before making electrical connection.

All electrical work should be carried out by a suitably qualified and competent person, in strict accordance with current national and local safety regulations (BS 7671 in the UK).

Installation, repairs and other work by unqualified persons could be dangerous. The manufacturer cannot be held liable for unauthorised work.

Ensure power is not supplied to the appliance until after any installation or repair work has been carried out.

The appliance must only be operated when built in. This is to ensure that all electrical parts are shielded. Live parts must not be exposed.

The **voltage and connected load** are given on the **data plate**. Ensure that these match the household mains supply.

Services

Connection should be made via a suitable isolator which complies with national and local safety regulations, and the On/Off switch should be easily accessible after the appliance has been built in.

If the switch is not accessible after installation (depending on country) an additional means of disconnection must be provided for all poles.

For extra safety it is advisable to install a suitable residual current device (RCD).

When switched off there must be an all-pole contact gap of at least 3 mm in the isolator switch (including switch, fuses and relays).

Important U.K.

This appliance is supplied for connection to a single phase 230-240 V 50 Hz supply with a 3-core cable.

The wires in the mains lead are coloured in accordance with the following code:

Green/yellow = earth

Blue = neutral

Brown = live

In other countries check these details with your supplier.

WARNING
THIS APPLIANCE MUST BE
EARTHED

Important

The electrical safety of this appliance can only be guaranteed when continuity is complete between the appliance and an effective earthing system, which complies with local and national regulations. It is most important that this basic safety requirement is regularly tested and if there is any doubt, the electrical wiring in the home should be inspected by a qualified electrician. The manufacturer cannot be held liable for the consequences of an inadequate earthing system such as an electric shock.

The manufacturer cannot be held liable for damage which is the direct or indirect result of incorrect installation or connection.

After sales service, data plate

In the event of any faults which you cannot remedy yourself, please contact

- your Miele Dealer or
- the Miele Service Department (see address on back cover).

When contacting Miele, please quote the model and serial number of your appliance. These are given on the data plate.

Please note that telephone calls may be monitored and recorded for training purposes.

Space in which to stick the extra data plate supplied with the appliance. Ensure that the model number is the same as the one on the front of these operating instructions.

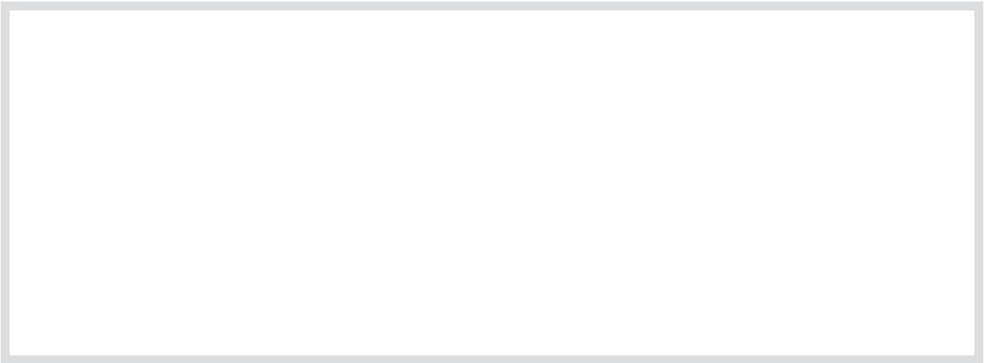



United Kingdom:

Miele Co. Ltd.
Fairacres, Marcham Road
Abingdon, Oxon, OX14 1TW
Tel: (01235) 554455
Fax: (01235) 554477
Customer Contact Centre Tel: (08707) 554466
E-mail: info@miele.co.uk
Internet: www.miele.co.uk

Australia:

Miele Australia Pty. Ltd.
A.C.N. 005635398
1 Gilbert Park Drive, Knoxfield, VIC 3180
Tel: (03) 9764 7130
Fax: (03) 9764 7149
Internet: www.miele.com.au

China

Miele Shanghai Rep. Office
Room 4105 - 6, 41 Floor
Plaza 66, 1266 Nan-Jing Road/ West
Shanghai 200040
Tel: +86 21 6288 4200
Fax: +86 21 6288 4100
E-mail: mieleshanghai@cn.miele.com
Internet: www.miele.cn

Hong Kong:

Miele (Hong Kong) Limited
AIA Plaza, 24 Floor
18 Hysan Avenue
Causeway Bay
Tel: +852- 2610-1331
Fax: +852-2610-1013
E-mail: mielehk@miele.com.hk
Internet: www.miele.hk

Ireland:

Miele Ireland Ltd.
Broomhill Road, Tallaght, Dublin 24
Tel: (01) 461 0710
Fax: (01) 461 07 97
E-Mail: info@miele.ie
Internet: www.miele.ie

New Zealand

Miele New Zealand Limited
Unit L, 10-20 Sylvia Park Road
Mt. Wellington, 1060, Auckland, NZ
Tel: (09) 573 1269
Fax: (09) 573 1268
Internet: www.miele.co.nz

South Africa:

Miele (Pty) Ltd
63 Peter Place, Bryanston 2194
P.O. Box 69434, Bryanston 2021
Tel: +27 (0) 11 548-1900
Fax: +27 (0) 11 548-1935
E-mail: info@miele.co.za
Internet: www.miele.co.za

Singapore:

Miele Southeast Asia
Miele Pte. Ltd.
163 Penang Road
04 - 02/03 Winsland House II
Singapore 238463
Tel: +65 6735 1191
Fax: +65 6735 1161
E-Mail: infosea@miele.com.sg
Internet: www.miele.sg

United Arab Emirates

Miele Appliances Ltd.
P.O. Box 11 47 82
Gold & Diamond Park
Sheikh Zayed Road
Building 6 / Offices Nos. 6-214 to 6-220
Dubai
Tel: +971-4-341 84 44
Fax: +971-4-341 88 52
E-Mail: info@miele.ae
Internet: www.miele.ae