



PPT-67

PPT SERIES

Pizza Prep Unit

MODELS

- PPT-67

FEATURES

CONSTRUCTION

- Design meets NSF 7 criteria
- Extra deep 19¹/₂" full length removable cutting board standard
- Stainless steel interior and exterior
- Foamed-in-place "low ODP" urethane insulated walls and doors
- Standard recessed door handles
- Adjustable, heavy-duty stainless steel wire shelves
- 5" diameter casters (2 locking, 2 non-locking)

- Door width: 24³/₈"
- Stainless steel louver distributes air to all areas of the unit
- Louver is food acid and stain-resistant
- Front air intake and rear exhaust
- **Nine 6" deep polycarbonate pans included with unit**

REFRIGERATION

- Refrigerant: R-134a
- Powerful forced-air refrigeration system holds constant temperature throughout cabinet
- Condensate drain pan

- Large evaporator fan for optimum cooling efficiency
- Self-contained, no plumbing required
- Temperature range: 33° to 41°F (1° to 5°C)
- R-factor (insulation efficiency rating): 14.75 for bottom, sides and rear, 13.12 for top

WARRANTY

- Standard limited four year extended compressor and one year limited parts and labor



PPT SERIES PIZZA PREP UNIT

TECHNICAL SPECIFICATIONS

MODEL	DIMENSIONS (in.)			DIMENSIONS (mm)			VOLTS	AMPS	UNIT H.P.	NO. OF SHELVES	PAN CAPACITY	CAPACITY CU. FT.	SHIP CU. FT.	SHIP WT. LB/KG
	L	D	H*	L	D	H*								
PPT-67	67	32 ³ / ₈	41 ³ / ₄	1701	822	1060	115	10.4	5/8	4	9	20.0	64.2	395/180

*Height includes casters.

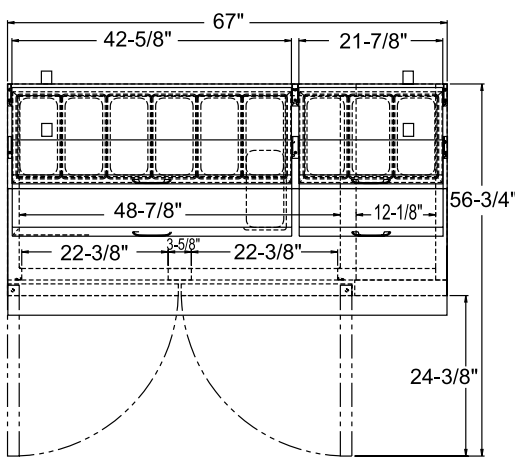

PLAN VIEW

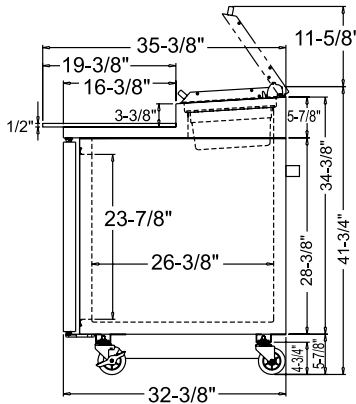

SIDE VIEW

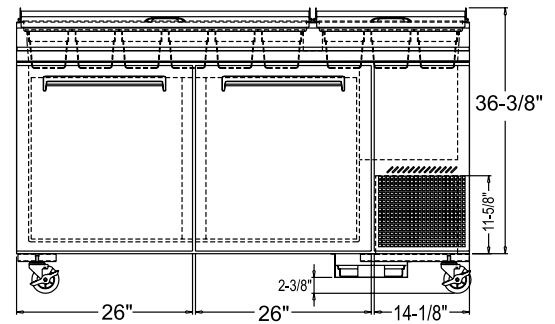

ELEVATION VIEW

LISTINGS



HOOKUP

Via plug in, 10 foot long, flexible 3 wire 16/3 cord with molded plug.



BID SPECIFICATIONS

Item no. PPT-67.

Provide _____ () Pizza Prep Unit(s), Master-Bilt model no. PPT-67.

Model design will meet NSF 7 criteria with a stainless steel interior and exterior. Standard features include adjustable, heavy-duty stainless steel wire shelves and 5" diameter casters. All doors to have standard recessed handles. Prep unit will also

feature a standard extra-deep 19¹/₂" full length removable cutting board. In addition, nine 6-inch deep polycarbonate pans will be included with the unit.

Forced-air refrigeration system will be self-contained and will use R-134a refrigerant. Each unit will also contain a standard condensate evaporator. A stainless steel louver will provide air distribution

throughout the unit. The temperature range will be 33° to 41°F (1° to 5°C).

Unit to have a standard limited four year extended compressor and one year limited parts and labor warranty.

Unit to be UL, C-UL and NSF listed.

NOTE: Cabinet designed for optimum performance in air-conditioned area at 75°F ambient and 55% relative humidity. All specifications subject to change without notice.



908 Highway 15 North • New Albany, MS 38652
PHONE: 800-647-1284 or 662-534-9061 • FAX: 800-232-3966 or 662-534-6049 • www.master-bilt.com

