

User's guide

EEB 9600.0

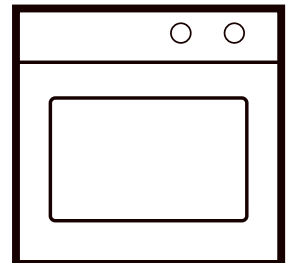

For your information...

Be sure to read the information in this manual carefully before you use your oven. You'll find important information about safety and how to use, maintain and service your appliance to ensure a long service life. If you experience any problems, first be sure to read the chapter titled, "What to do if trouble occurs...". Usually it's easy to solve minor problems yourself and avoid unnecessary service costs.

Please keep this manual in a safe place and pass it on to future owners for their information and safety.

The following symbols are used in this operating manual:

 The warning triangle will alert you about possible health risks or things that can cause potential damage to your appliance.

 You'll find useful hints and information when you see this symbol.

Warranty

This warranty is extended to the original purchaser and succeeding owners for products purchased for ordinary home use. It does not cover its use in commercial situations. Should the appliance be sold by the original purchaser during the warranty period, the new owner will continue to be protected until the expiration date of the original purchaser's warranty period. Save your dated receipt or other evidence of the installation/occupancy date. Proof of original purchase date is needed to obtain service under warranty. The warranty applies even if the owner should move during the warranty period.

KÜPPERSBUSCH does not assume any responsibility for consequential or incidental damages. This warranty provides you with certain legal rights. You may also have other rights which may vary from state to state.

What Is Covered

For one full year from the date of the original purchase, we will provide parts, service and labor in your home to repair or replace any part of the oven that fails because of a defect in materials or workmanship. This service is provided free of charge. All warranty service will be provided by an authorized technician during normal business hours.

What Isn't Covered

1. Service by an unauthorized agency will not be reimbursed. Likewise, the warranty doesn't cover any damage or repairs due to service performed by an unauthorized agency, or by the use of unauthorized parts.
2. Service visits to teach you how to use the appliance.
3. Service visits to correct the installation. You are responsible for providing electrical wiring and other connecting facilities.
4. Reset circuit breakers or replace home fuses.
5. Damage resulting from accident, alteration, misuse, improper installation, abuse or installation not in accordance with local electrical codes, or improper storage of the appliance.
6. Repairs due to other than normal household use.

For technical information and/or
replacement parts, please contact the
Küppersbusch Customer Care line
at
1-800-459-0844

For the most efficient assistance,
please have the Model and Serial
numbers for the appliance available.

Contents

Safety instructions	3
Before using the oven the first time	3
Disposing of the packaging and the old appliance	
Setting the clock	
Initial cleaning	
Your appliance at a glance	4
Using your oven	5
General	
Symbols and operating modes	
Heating-up indicator and mode indicator	
Turning the oven light on and off	
Turning the oven on and off	
Oven trays to use with rack levels	
Rack levels	
Telescopic glide-out shelves (acc.-no.601)	
How to use your oven	6
Fast preheating	
Roasting	
Recommended Roasting Temperatures	
Recommendations for souffles and gratins	
Recommendations for frozen prepared meals	
Baking	
Baking pizza	
Tips on the table "Recommended temperatures for baking"	
Recommended temperatures for baking	
Grilling	
Recommended temperatures for grilling	
Defrosting	
Preserving	
How to use the telescopic glide-out shelves (acc.-no. 601)	10
Inserting the oven trays correctly	
Pulling out the trays	
Pushing in the trays	
Shelf levels, cooking times and temperatures	
Special accessories	
The electronic timer	11
Setting/changing the clock	
Setting the alarm time	
How to program the switching operations	
Changing the setting	
When the cooking time is finished	
Setting the cooking time \rightarrow (switch-off function)	
Setting the finish time \rightarrow (switch-off function)	
Automatic turn-on and shut-off	
The roasting thermometer	13
How to use the roasting thermometer	
Setting the core temperature function	
Core temperature function with delayed start	
Recommended core temperatures	
Cleaning and care	14
For all surfaces	
Remove caking	
Using a cleaning scraper	
Information about oven sprays	
Enamel	
Stainless steel	
Glass	
Buttons	
Removing and installing the oven door	
Removing and installing the side racks	
Folding heating element down/up	
Regenerating the ökotherm [®] catalyst	
What to do if trouble occurs	16
Replacing a halogen bulb	
Rating label	16

Safety instructions



- Be sure your appliance is properly installed and grounded by a qualified technician.
- **WARNING!** To reduce the risk of tipping of the appliance, the appliance must be secured by properly installed anti-tip devices. Check after installation that the fastening clips have clicked into their seatings in the recess fixtures properly and that the appliance cannot be moved.
- KÜPPERSBUSCH built-in ovens may only be connected to the corresponding KÜPPERSBUSCH built-in cook tops by a qualified and authorized technician. Only qualified personnel should perform installations and repairs on electrical appliances. Do not repair or replace any part of the appliance unless specifically recommended in this manual. Do not put your safety at risk.
- Do not operate the appliance until it has been properly installed within cabinetry.
- **Do not leave children alone!** Children should not be left alone or unattended in area where appliance is in use. They should never be allowed to sit or stand on any part of the appliance.
- The surfaces of the oven door and the appliance are hot when in operation. Do not let children in, on or around the appliance or its controls!
- Never use your appliance for warming or heating the room.
- Make sure connection cables for electrical devices are not jammed in the oven door.
- **WARNING!** Never use steam and/or pressure cleaning machines to clean the oven! This can damage the unit and increase the risk of personal injury.
- The appliance is intended for residential use only. Use for any other purpose is at the owner's risk and could be dangerous. The manufacturer cannot be held responsible for damage caused by improper use of this appliance.
- When performing repairs and replacing oven light bulbs, be sure to disconnect the power supply by either removing the plug or manually "tripping" the circuit breaker.
- Do not store objects in your oven that could become a hazard if the oven is unintentionally turned on.
- **CAUTION!** Items of interest to children should not be stored in cabinets above a cooktop. A child can be seriously injured by climbing on a cooktop to reach items.
- Do not heat unopened food containers. Build-up of pressure may cause container to burst and result in injury.
- Heat resistant oven mitts/gloves are recommended when placing items in the oven, turning them, or removing them from the oven. The top heating element and oven racks can become very hot and cause burns, even though they are dark in color.
- Use only dry potholders. Moist or damp potholders on hot surfaces may result in burns from steam. Do not let potholder touch hot heating elements. Do not use a towel or other bulky cloth.
- Always place oven racks in desired location while oven is cool. If rack must be moved while oven is hot, do not let potholder contact hot heating element in the oven.
- Be careful when opening the oven door when the oven is hot. Don't position yourself directly in front of the oven door. Allow hot air or steam to escape before placing or removing food.
- Wear proper apparel. Loose-fitting or hanging garments should not

be stored in an oven or near surface units.

- Do not use water on grease fires. Smother fire or flame or use dry chemical or foam-type extinguisher.
- The oven door must close well. In the event of damage to the hinges or to the glass pane, do not use the appliance until it's been repaired and checked by a qualified professional.
- If the door sealing is damaged, it must be replaced. The oven must not be used with damaged door sealing.
- Keep the oven vent ducts unobstructed.
- Always be sure to close the oven door completely.
- Keep a distance of at least 5 cm (2 inches) from the grill and top heat.
- Only use the original roasting thermometer.
- Do not jam the cable of the roasting thermometer in the oven door.
- Take roasting thermometer out of the oven when not being used.
- Keep it at a distance of at least 5 cm (2 inches) from the grill and top heat.

Before using the oven the first time

Disposing of the packaging and the old appliance

Be sure to dispose of the transport packaging properly. Disposal should not have a negative impact on the environment. Recycling the packaging saves raw materials and reduces the amount of waste.

Be sure to dispose of your old appliance properly, as well. Even if it can no longer be used, it still contains useful materials. Before discarding an old appliance, disconnect the power cord and remove the door to prevent it from becoming a hazard.

Setting the clock

 **The oven will not function until the clock is set.**

The clock must be set before the oven is used and whenever power has been disconnected to the appliance. If the clock needs to be set, you will see "0.00" flashing in the display.

- Use "+" and "-" to set the right time. It takes approximately three seconds for the time to be accepted and to stop the display from blinking.



Initial cleaning

- Remove labels, accessories and packaging from the oven.
- Clean the appliance before preparing food for the first time. Clean the drip pan, oven rack etc. with a damp cloth and a solution of warm water and a non-abrasive detergent. Dry the interior with a soft cloth.
- **Heating the oven**
Close the oven door.
Heat up the oven with top heat/bottom heat at 480 °F/250 °C for 60 minutes.
Make sure that the room is well ventilated.

Your appliance at a glance

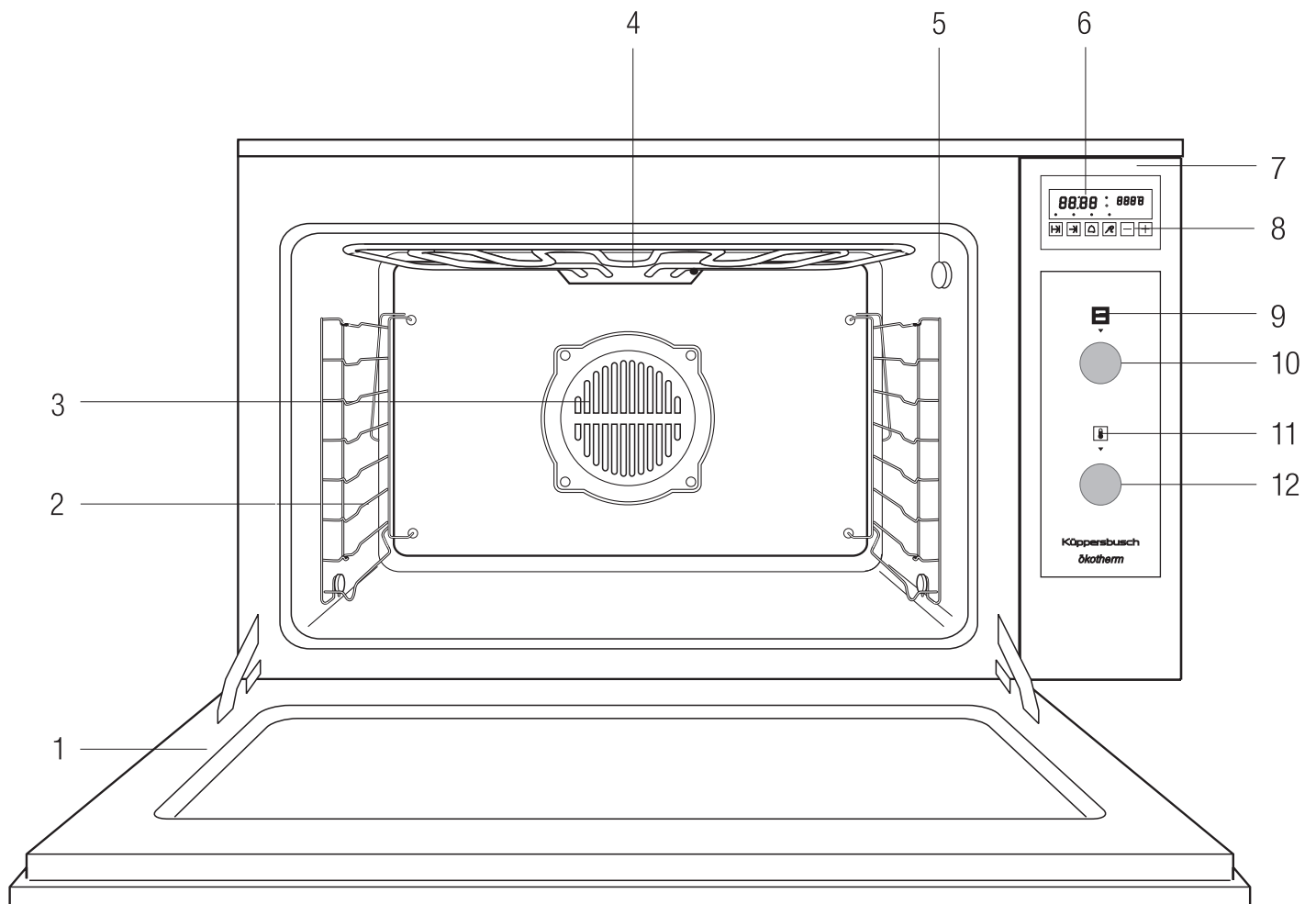

- 1 Oven door
- 2 Rack levels
- 3 Hot air fan
- 4 Fold-down grill (top heat and grill)
- 5 Socket for roasting thermometer
- 6 Timer display
- 7 Control panel
- 8 Timer sensor buttons
- 9 Mode indicator
- 10 Mode selector
- 11 Heating-up indicator
- 12 Temperature control

Accessories supplied:

- Oven rack
- 2 Baking trays, enamel
- Drip pan (enamel)
- Roasting thermometer

Accessories available:

- Maxi pizza stone (acc. No. 146)
- Telescopic glide-out shelves (acc. No. 601)

for the telescopic glide-out shelves:

- Oven rack, depressed, i.e. for large poultry (acc. No. 752)
- Glass drip pan, suitable only for accessory No. 752 (acc. No. 753)

Using your oven

General

- ⚠ Please note the safety instructions on page 3!
- ⚠ **Attention! Risk of overheating!** Do not cover the bottom of the oven with aluminum foil, or place any kind of pot or pan directly on it. This can cause heat to build up and it can damage the enamel.
- ☞ When the oven is in use, it becomes hot. In order to cool the housing, the cooling fan is switched on as soon as the housing heats up. The cooling fan continues to run until the housing has cooled down - even after the appliance has been switched off. The fan noises are normal.
- ☞ If you are preparing a dish with alcohol or yeast as an ingredient, and are using Hot air convection, Intensive hot air convection or Pizza Mode, there will be a noticeable vinegar odor. If you find the odor disturbing, use Top/Bottom Heat or another alternate mode.

Symbols and operating modes

Switch symbol	Operating mode	intended for
0	Off	
	Lighting	
	Cold air convection	Without temperature setting, for gently defrosting and cooling food.
	Hot air convection	With temperature setting, for roasting, baking and cooking on several levels.
	Top heat/Bottom heat	Preheating, baking and roasting on one level
	Bottom heat	Prebaking very moist cake
	Top heat	Browning toppings
	Grilling	Grilling small portions. Position the pieces of meat in the center of the oven rack.
	Large area grill	Grilling larger portions such as steaks, fish and sausages, but also for browning toast dishes and gratins.
	Intensive hot air convection	Baking large flat cakes with a dry topping (such as a crumble topping), intensive roasting of large poultry like turkey.
	Pizza mode	Baking bread, pizzas and moist cakes, making preserves.

Heating-up indicator and mode indicator

The heating-up indicator on the control panel will light up while the appliance is heating up and will go out as soon as it reaches the set temperature. It also comes on during operation when the oven is heated to maintain the temperature you want.

The mode indicator is on as long as the oven is in use.

Turning the oven light on and off

The oven lighting stays on when the operating mode switch is up – except on position “0”. The light stays off when the mode switch is depressed.

The oven light functions regardless of which mode is selected. The light can also be turned off while the oven is in use. This will save energy and increase the life of the halogen lamps.

Turning the oven on and off

- ☞ The controls are “pop out” in nature and can be locked in every setting. They pop out with a slight press of the finger. No settings can be made while the controls are locked.

Selecting the operating mode:

- Turn mode selector (upper switch) to the right until the arrow points at the desired mode.



Selecting the temperature:

- Turn temperature controller (lower switch) to the right until the arrow points at the desired temperature.
The oven heats up and the heating-up indicator lights up.



Turning the oven off:

- Turn both switches to the “0” position.

Oven trays to use with rack levels

- ☞ If you use telescopic glide-out shelves (acc. no. 601) please note the instructions on page 10.

Baking trays:

- Lift slightly when removing.
Place the baking trays back into the oven, with the sloping edge pointing toward the oven door.
- Push the drip pan and baking tray with the two slots right at the back into the oven.

Oven rack:

- Make sure the catches of the racks always point towards the back (away from you).

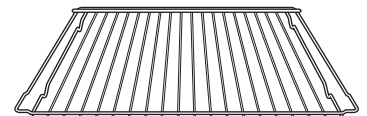

Rack levels

- ☞ If you use telescopic glide-out shelves (acc. no. 601) please note the instructions on page 10!

There are eight levels in the side racks. The rack levels are numbered from 0 to 7 from the bottom up. For example, the drip pan can be inserted into rack level 0.

Side racks:

Rack level 0 is the lowest level possible.

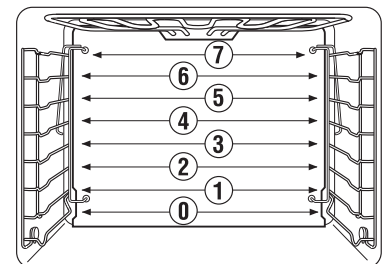

Telescopic glide-out shelves (acc.-no.601)

These are oven rails that are available as accessories. They replace the side racks and make it easier to work in a hot oven.

Trays or oven racks are placed on the glide-out shelves. They can be pulled out separately and independently of each other. If your oven is fitted with glide-out shelves, please read the instructions on page 10.

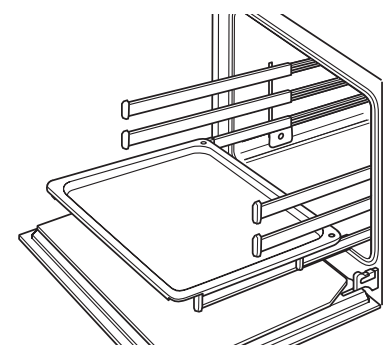

How to use your oven

☞ The rack level indicated in the following sections are optimal for the side racks. When using the telescopic glide-out shelves in your oven, you'll get the best results by following the indications for the rack levels on page 10.

Fast preheating

- ☞ Do not put food for roasting or baking into the oven until fast preheating is over and the oven has been set to the normal mode of operation.
- ☞ An empty oven can be preheated relatively quickly on the Pizza mode 🍕.
 - Close the oven door.
 - Set the mode selector switch to Pizza mode 🍕.
 - Set the temperature you want. The heating-up indicator will come on.
 - As soon as the heating-up indicator goes off, select your desired mode.
 - Put the food into the oven.

Roasting

- ☞ Use the drip pan and the oven rack.
- ☞ You can roast very accurately using the roasting thermometer. Please read the notes on p. 13.
- Only cook meat or fish in the oven if it weighs more than 2 lbs.
- The roasting time is determined by the type of meat you are roasting, the quality of the meat, and the thickness of the joint. To measure the joint, lift it slightly as it collapses under its own weight.
- If the meat you are roasting has a layer of fat, cook it twice as long.
- If you are cooking several small pieces of meat or small poultry in the oven, increase the cooking time by about 10 minutes per piece. Roast a single chicken for about an hour, roast two chickens 65-75 minutes.
- ☞ Be sure to follow the instructions about rack levels!

Rack levels (count from bottom!):

Intensive hot air convection 🌀 Drip pan: rack level 0, oven rack: rack level 1

Hot air convection 🌀 Drip pan: rack level 1, oven rack: rack level 2

Top heat/bottom heat 🔥 Drip pan: rack level 1, oven rack: rack level 2

Roasting on the oven rack

- Cook large roasts directly in the drip pan or on the oven rack with the drip pan inserted underneath (i.e. turkey, 3-4 chickens).
- Turn the roast after 2/3 of the cooking time unless you are using the Hot air convection mode 🌀.

Roasting in a pan (oven)

- ☞ Select Intensive hot air convection 🌀 at 350-400 °F / 180-200 °C.
- Roast lean meats in the roasting pan with the lid closed (i.e. veal roast, marinated beef, braised beef or frozen meat). The meat remains juicier that way.
- Use any kind of pan (stainless steel, enameled, cast iron or glass) that doesn't have plastic or wooden handles.
- If you use an earthenware cooking pot, follow the manufacturer's instructions.

The following procedure is recommended:

- Rinse out the pan with water or grease it lightly.
- Prepare the meat with desired spices and place it into the pan. Put the lid on the pan and place the pan on the rack in the cold oven.
- Select Intensive hot air convection 🌀 and set the temperature to between 350-400 °F / 180-200 °C.

Recommended Roasting Temperatures

The recommended temperatures for the preferred operating modes **have been highlighted**.

Type of meat	Hot air convection 🌀	Top heat/ bottom heat 🔥	Intensive hot air convection 🌀	Roasting time per cm of the thickness of the joint in mins.
	Temperature in °F			
Joint of beef	320	340-375		18
Roast beef	355	390-430	355-390	8-10
Fillet	355	390-430	355-390	8
Veal	320	340-375	320-355	12
Roast pork	320	340-375	320-355	12-15
Smoked loin of pork	320	340-375	320-355	8
Shoulder of pork	320	340-375	320-355	12-15
Roast pork with crackling	320	340-375	320-355	12-15
Game	320	340-375		15
Fillet of game	355	390-430	355-390	8-10
Mutton	300-320	340-375		15
Duck	320	340-375	320-355	12
Goose	320	340-375	320-355	12
Chicken	320	355-390	320-355	8*
Turkey	320	390-430	320-355	12
Fish	320	390-430		8

*whole chicken 45 - 60 min.





Type of meat	Hot air convection 🌀	Top heat/ bottom heat 🔥	Intensive hot air convection 🌀	Roasting time per cm of the thickness of the joint in mins.
	Temperature in °C			
Joint of beef	160	170-190		18
Roast beef	180	200-220	180-200	8-10
Fillet	180	200-220	180-200	8
Veal	160	170-190	160-180	12
Roast pork	160	170-190	160-180	12-15
Smoked loin of pork	160	170-190	160-180	8
Shoulder of pork	160	170-190	160-180	12-15
Roast pork with crackling	160	170-190	160-180	12-15
Game	160	170-190		15
Fillet of game	180	200-220	180-200	8-10
Lamb	150-160	170-190		15
Duck	160	170-190	160-180	12
Goose	160	170-190	160-180	12
Chicken	160	180-200	160-180	8*
Turkey	160	200-220	160-180	12
Fish	160	200-220		8

*whole chicken 45 - 60 min.

Recommendations for souffles and gratins

Dish	Hot air convection 		Cooking time in minutes
	Rack level	Temperature	
Pasta Bake	2	340-355 °F / 170-180 °C	40-60
Lasagne	2	320-355 °F / 160-180 °C	30-45
Vegetable Gratin	2	355-390 °F / 180-200 °C	15-30
Browned Baguettes	2	390-430 °F / 200-220 °C	15-30
Sweet Puddings	2	320-355 °F / 160-180 °C	40-60
Stuffed Vegetables	2	320-355 °F / 160-180 °C	40-70
Potato Bake	2	320-355 °F / 160-180 °C	50-80

Recommendations for frozen prepared meals

Food to be cooked	Shelf	Oven function	Temperature	Time in minutes
Frozen pizza (preheat 250 °C)	0	Pizza function 	480 °F 250 °C	6-9
Chips (600 - 1000g)	2	Hot air 	355-390 °F 180-200 °C	20-30
Baguettes	2	Hot air 	follow manufacturer's instructions	follow manufacturer's in- structions
Fruit flan	2	Hot air 	follow manufacturer's instructions	follow manufacturer's in- structions

Baking

Quantities for one baking tray (i.e. cake mix, yeast dough):

Cake mixture

350 g shortening, 270 g sugar, 1 vanilla sugar, 6 eggs, 670 g flour, 6 level tsp. baking powder

Yeast dough

670 g flour, 50 g yeast, 1 tsp. sugar, 1/4 l milk, 100 g sugar, 2 eggs, 1 vanilla sugar, 100 g margarine.

Hot air convection

 No need to preheat the oven - you can bake on several levels simultaneously.

Rack levels:



1 tray: 3rd rack level from the bottom

2 trays: 3rd and 6th rack levels from the bottom

- If you are baking several cakes in baking pans, add 10- 15 minutes baking time for each pan.
- Remove the baking pans individually, depending on how well browned the cakes are.
- If your recipe doesn't provide instructions for baking by hot air convection, bake using hot air convection  at a temperature of 320 ° F / 160 °C.
- **Important:** When baking cakes with a moist fruit topping, the development of humidity will be high. Only bake one cake at a time.

Top/Bottom heat

 Preheating - baking on one level

- Preheat the oven by Pizza mode , and when the temperature has been reached, set the oven back to Top/Bottom heat .
- Baking pans made of black metal and aluminium are recommended.

Intensive hot air convection

 No need to preheat the oven - baking on one level

- Only for large flat cakes with a dry topping, such as a crumble topping.

Pizza mode

 Baking on one level

- for moist cakes
- for pizzas: preheat the oven with a baking tray or a pizza stone (accessory)
- for bread: preheat the oven

Baking pizza

 Select the Pizza mode  at 480 °F / 250 °C.



– If you use a pizza stone (special accessory), the pizza will have a very crispy base. Preheating time: at least 30 minutes.

Read the instructions enclosed with the pizza stone.



Basic recipe for pizza dough

4 1/4 cups of flour, 20 g of yeast, 1 1/2 cups of lukewarm water, 3 tablespoons of olive oil, 2 teaspoons of salt, 2 teaspoons of sugar.

Baking pizza on a baking tray

- Make a yeast dough out of the specified ingredients.
- Allow the dough to rise for approx. 30 minutes until it has doubled in size.
- Knead the dough for a few minutes and allow it to rise for another 15 min.
- Preheat the oven in Pizza mode  at a temperature of 480 °F / 250 °C.
- Grease the baking tray. If you are making small round pizzas, insert the baking tray into the oven and preheat.
- Roll out the dough, place on a baking tray and form an edge.
- Add your desired toppings quickly so the dough doesn't get moist.
- **Small pizzas:** put dough with topping on the preheated baking tray.
- Place the baking tray in rack level 0.
- Bake for approx. 15 minutes in Pizza mode , at 480 °F / 250 °C.

Baking pizzas on the pizza stone

- Prepare the pizza dough as described above.
- Place the pizza stone on the oven rack and insert at rack level 0.
- Preheat the oven in Pizza mode  at a temperature of 480 °F / 250 °C
- Dust the lifter with flour before placing the dough on top. Add toppings quickly so the dough doesn't become moist. Don't leave the pizza on the lifter for too long, or the dough won't slide off.
- When preheating is over, push the pizza off the lifter onto the hot pizza stone.
- Bake for approx. 15 minutes in Pizza mode , at a temperature of 480 °F / 250 °C.

























Tips on the table "Recommended temperatures for baking"

The table on page 8 contains a selection of baked items, the necessary temperatures, cooking times and rack levels.







- Temperatures are generally given in ranges as they are dependent upon the composition, quality and shape of the dough.
- Begin with the lower temperature value the first time and only select a higher temperature if necessary – i.e. if you want more browning or the baking time is too long.
- If you don't find any specified temperatures in your own recipes, refer to the table and use a similar cake as a reference.
- Food with different heights can result in different degrees of browning at the beginning of the baking process. Don't change the temperature setting. Browning will even out during the course of baking.

Recommended temperatures for baking

The recommended temperatures for the preferred operating modes **have been highlighted**. Please refer to the tips on p. 7!

Type of cake or biscuit	Hot air convection 		Top heat/bottom heat 		Intensive hot air convection 		Baking time in minutes
	rack level	Temperature	rack level	Temperature	rack level	Temperature	
Cake mixture							
Ring cake	3	300-320 °F 150-160 °C	1	340-355 °F 170-180 °C			50-70
Tin cake	3	300-320 °F 150-160 °C	1	340-375 °F 170-190 °C			50-70
Madeira cake	3	300-320 °F 150-160 °C	1	320-355 °F 160-180 °C			60-70
Gateaux and flans	3	300-320 °F 150-160 °C	1	340-355 °F 170-180 °C			40-60
Flan bases	3	340-355 °F 170-180 °C	2	355-390 °F 180-200 °C			20-30
Fine fruit flans	3	300-320 °F 150-160 °C	1	340-355 °F 170-180 °C	3	 300-320 °F  150-160 °C	45-60
Small biscuits	3	300 °F 150 °C	2	340-355 °F 170-180 °C			15-30
Large flat cakes:							
with a dry topping	3	300-320 °F 150-160 °C	2	355-375 °F 180-190 °C	3	 300-320 °F  150-160 °C	30-45
with a moist topping	3	320-340 °F 160-170 °C	2	340-355 °F 170-180 °C	3	 320-340 °F  160-170 °C	40-60
Kneaded dough							
Flan bases	3	340-355 °F 170-180 °C	2	355-390 °F 180-200 °C			25-35
Cheese cake	3	285-300 °F 140-150 °C	1	320-340 °F 160-170 °C	3	 285-300 °F  140-150 °C	70-90
Small biscuits	3	285-300 °F 140-150 °C	2	355-375 °F 180-190 °C			15-35
Large flat cakes:							
with a dry topping	3	300-320 °F 150-160 °C	2	355-375 °F 180-190 °C	3	 300-320 °F  150-160 °C	30-45
with a moist topping	3	320-340 °F 160-170 °C	2	340-355 °F 170-180 °C	3	 320-340 °F  160-170 °C	30-50
Leavened dough							
Ring cake	3	300-320 °F 150-160 °C	1	350-355 °F 175-180 °C			40-60
Yeast cake	3	300-320 °F 150-160 °C	2	350-355 °F 175-180 °C			40-50
Rich sweet bread (preheated)	3	300-320 °F 150-160 °C	2	350-355 °F 175-180 °C			50-70
Small biscuits	3	285-300 °F 140-150 °C	2	355-390 °F 180-200 °C			12-25
Large flat cakes:							
with a dry topping	3	300-320 °F 150-160 °C	2	350-355 °F 175-180 °C	3	 300-320 °F  150-160 °C	30-45
with a moist topping	3	320-340 °F 160-170 °C	2	340-355 °F 170-180 °C	3	 320-340 °F  160-170 °C	40-60
Sponge cake							
Gateaux and flans	3	300-320 °F 150-160 °C	2	350-355 °F 175-180 °C			30-45
Rolls	3	340-355 °F 170-180 °C	2	355-390 °F 180-200 °C			12-25
Biscuits made with white of egg							
Meringue	3	175-195 °F 80-90 °C	2	210-250 °F 100-120 °C			80-90
Cinnamon stars	3	210-250 °F 100-120 °C	2	250-285 °F 120-140 °C			15-20
Macaroons	3	210-250 °F 100-120 °C	2	250-285 °F 120-140 °C			20-40
Other doughs							
Puff pastry	3	340-355 °F 170-180 °C	2	375-410 °F 190-210 °C			15-30
Puff pastry made with leavened dough	3	340-355 °F 170-180 °C	2	375-410 °F 190-210 °C			30-40
Puff pastry made with curd cheese	3	320-355 °F 160-180 °C	2	355-390 °F 180-200 °C			30-40
Choux pastry	3	340-355 °F 170-180 °C	2	375-410 °F 190-210 °C			30-40
Dough made with curd cheese and oil	3	300-320 °F 150-160 °C	2	340-355 °F 170-180 °C			30-40
Honey cake	3	285-300 °F 140-150 °C	2	340-355 °F 170-180 °C			30-45
Bread and pizza							
Leaven and bread made with yeast (preheat: 445 °F/230 °C, prebake: 10 min., 445 °F/230 °C)			2	355 °F 180 °C	2/3	 320 °F  160 °C	50-65
Bread made with yeast/white bread.			2	390 °F 200 °C	3	 355 °F  180 °C	30-50
Pretzels (preheat: 445 °F/230 °C)	2	390 °F 200 °C	2	430 °F 220 °C			15-20
Pizza (preheat: 480 °F/250 °C)					0	 480 °F  250 °C	12-15



Grilling

- ⚠ Always close the oven door when grilling!
- ☞ Set the operating mode Grill  for small portions or Large area grill  for large portions.
Set the temperature control to . **Exception:** When grilling larger roasts, select a temperature between 400-475°F / 200-250 °C to prevent burning.
- Preheat the oven for 5-10 minutes.
- Put the food on the oven rack.
- Push the drip pan into the 2nd or 3rd rack level and the oven rack into the rack level as specified in the chart.
- Select Grill  or Large area grill .
- Set temperature control to .
- Close the oven door.



Recommended temperatures for grilling

Dish	Rack level	Grill		Large area grill	
		1 st side	2 ^d side	1 st side	2 ^d Side
		in minutes			
Pork chops/Escalope	7	10-13	8-10	10-15	10-12
Fillet of pork	6	12-15	8-10	14-16	12-14
Sausages	6	10-12	8-10	15-20	10-15
Shashlik	6	8-10	6-8	18-20	10-12
Rissoles	6	10-12	8-10	10-15	12-14
Beef steak	7	7-9	6-8	10-11	10-12
Slices of liver	7	4-6	3-5	7-8	7-9
Escalope of veal	6	7-10	5-8	9-11	9-12
Veal steak	6	8-10	6-8	10-12	10-12
Mutton chops	7	10-12	8-10	12-14	12-14
Lamb chops	7	10-12	8-10	12-14	12-14
Half a chicken	4	12-15	10-14	16-20	15-18
Fillet of fish	7	8-10	6-8	10-11	10-14
Trout	4	7-10	6-8	11-15	10-14
Toast	6	3-5	3-5	6-7	6-7
Toasted sandwiches	5	8-10		12-14	

Defrosting

- ☞ Set the mode selector to Cold air convection  (Hot air convection without temperature setting). Don't countersink the mode selector so that the oven interior stays illuminated. The lighting will heat the oven up slightly: perfect for mild defrosting.
- ☞ When defrosting frozen food, please follow the directions on the packaging.
- Remove the frozen food from the package, place it in a dish and put it in the oven with the rack on the second rack level from the bottom.
- Set the mode selector to  and the temperature control to "0" .

Preserving

- ⚠ **Attention!** During the preserving process a lot of moisture develops in the oven interior due to water evaporation. This moisture escapes through the ventilator openings and can cause the control panel to heat up.
- ⚠ **Attention!** Don't pour water into the drip pan! Steam can escape and you could burn yourself.
- ⚠ **Attention!** Don't use jars with twist-off[®] lids if they have already been used. The jars could explode!
- ☞ Use conventional preservative jars with a rubber ring and glass lid or standard jars with a twist-off[®] lid (only with new lid). Don't use metal cans.
- ☞ Select Pizza mode .
- Only use fresh food and follow a recipe.
- Don't prepare more than 8 quart-sized preserving jars at a time.
- Use jars that are the same height and fill 3/4 full with the same contents.
- The jars shouldn't touch each other.
- Place the drip pan on the 1st rack level from the bottom.
- Set 2 cups with water in the drip pan.
- Select Pizza mode  at 320 °F / 160 °C and follow the preserving process.
After 10-20 minutes (jars with a capacity of 1 qt.) the liquid in the jars will start to bubble, beginning usually in the jar on the front right.

Fruits

- Then switch off the oven and keep the jars in the closed oven for another 30 min. (approx. 15 min. if preserving sensitive fruits like strawberries.)

Vegetables and meat

- When the liquid starts to bubble, turn the oven down to 210 °F / 100 °C and continue to heat for 30-60 more minutes.
- Then switch off the oven and keep the jars in the closed oven for another 30 min.

How to use the telescopic glide-out shelves (acc.-no. 601)

⚠ Be careful when working around a hot oven. Use oven mitts, gloves or other protective material.

Inserting the oven trays correctly

- ➡ Push the individual telescopic glide-out shelves completely into the oven to safely position the trays and oven racks!
- Push all the glide-out shelves completely into the oven.
- Position the trays with the holes at the rear

Oven racks with cross bars should point toward the front.

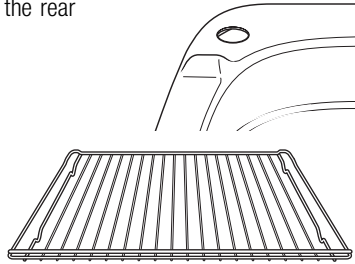

- Place the trays and oven racks with the back edge **on the front side** of the glide-out shelf and push into the oven.

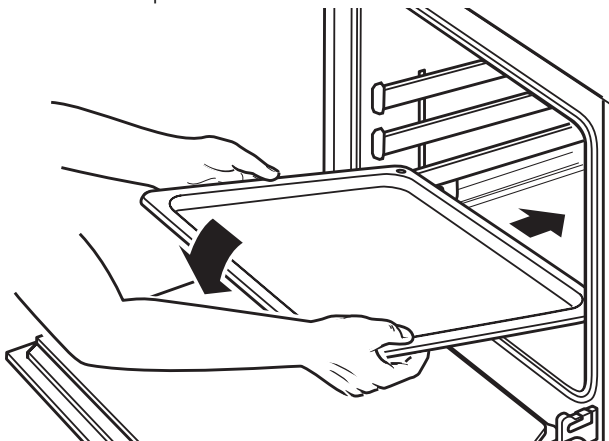

- ➡ Don't clasp the holes in the back of the oven. The holes don't have any function, except during production!

Pulling out the trays

- Use mitts or gloves to pull the trays and oven racks out of the oven. The trays can be pulled out by their front edge, up to the front edge of the individual telescopic glide-out shelves. The oven racks do not move on the glide-out shelves when they are being pulled out.
- ➡ The two top racks can be pulled out to the simple length, the bottom racks can be pulled out a little more..

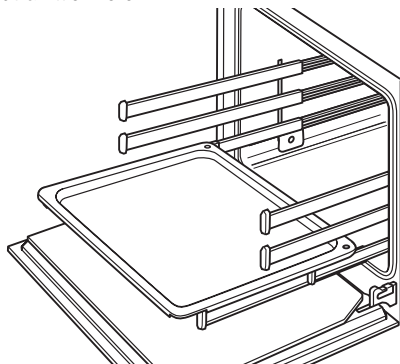

Pushing in the trays





- Use a cloth or oven mitt to slowly push the glide-out shelves completely .

Shelf levels, cooking times and temperatures

The individual telescopic glide-out shelves have three shelf levels (1-3) which are counted from the bottom up. The recommended times, temperatures and modes in the instructions for use of your oven also apply to the use of the individual telescopic glide-out shelves.

The shelf levels provided in this users guide are only suitable for shelf racks.

- ➡ The following levels for the individual telescopic glide-out shelf are recommended:

Food	Hot air 	Top heat/ Bottom heat 	Intensive hot air convection Pizza mode 	Grill  or 
	Rack levels (counted from the bottom up)			
Baking				
Cake on 1 baking tray	1	1	1	
Cake on 2 baking trays	1,2			
Cakes in pans i.e. Bundt cake)	1	1		
Roasting - drip tray and oven rack				
Large pieces of meat or poultry	1*	1*	1*	
Grilling				
Flat pieces of meat/fish				3
Thick pieces of meat/fish				2

* Use the depressed oven rack with the glass drip pan (accessory) when roasting large poultry.

Special accessories

Oven rack, depressed, and glass drip pan:

For roasting very large poultry, you need the depressed oven rack with the glass drip pan. When cooking two dishes on two levels, put the depressed oven rack at the lowest level so you have more space.

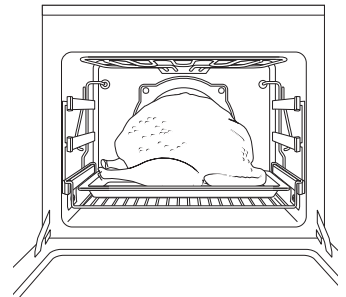

Accessory numbers:

- Oven rack, depressed: acc.-no. 752
- Glass drip pan: acc.-no. 753

The electronic timer

☞ Look on p. 13 to learn how to use the core temperature function.

The electronic timer is a short-time alarm and also controls the oven in several other ways. You can use it to set the cooking time, the finish time and the core temperature. All functions are available in any mode or temperature selection.

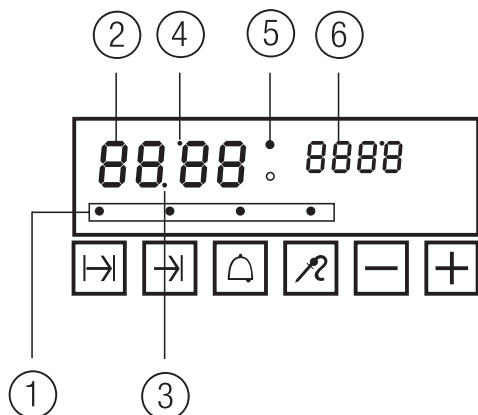

Display:

- ① Lights (for each selector button/function)
- ② Time, alarm time (actual value in each case)
Core temperature (value set)
- ③ lower light will be illuminated when the time is set for a.m
- ④ upper light will be illuminated when the time is set for p.m
- ⑤ Lights will be illuminated when the oven is switched on.
- ⑥ Core temperature (actual value)

Selector buttons:

- ⏪ Cooking time
- Finish time (with roasting thermometer: start time)
- 🔔 Alarm time
- 🌀 Core temperature function

Adjust:

- +/- for altering the values of all functions.

Setting/changing the clock

- Push simultaneously “⏪” and “→”, until the time in the display flashes.

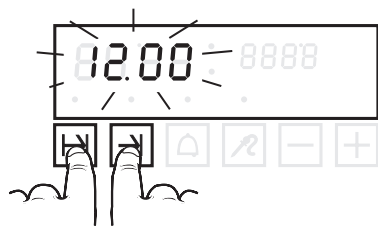

- Adjust as needed using “+”/“–”.
- Wait for the display to stop flashing. The time will then be accepted, and the dot between the hour and the minutes will flash every second.



Setting the alarm time

You can use the alarm on its own, without effecting the oven.

- Press “🔔”. The lamp will flash.
The display will read “0.00”.

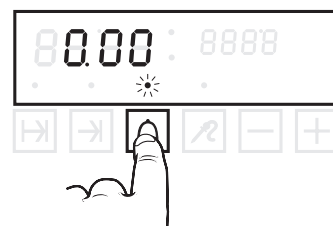

- Use “+”/“–” to set the timer in minutes and seconds.
- Start the timer with “🔔” or wait until the light stops flashing. You will see the time remaining in the display until the buzzer sounds.



You'll hear an acoustic signal when the alarm time has elapsed.

- Press any button to stop the buzzer. The normal clock will appear on the display.

How to program the switching operations

1. Select the operation:

- Press the selector button for the desired operation. The light above the button you pressed will start flashing and a number will appear in the display.

2. Altering/adjusting the operation:

- Adjust the value shown, using “+” and “–”.

3. Start the operation:

If you don't press another button for 3 seconds, the operation will start automatically and the light will stay on.

☞ You can reduce the time by pressing a selector button:

- the previously selected button confirms the input and starts the operation.
- another button confirms the input and selects the new operation you've chosen.

4. Setting the oven functions (switching functions only):

- Use the mode selector to select the mode and the temperature control to select the temperature.
You can set the temperature and mode before programming the timer.

Changing the setting

If you want to change a setting you've made – even if the operation is running – push the appropriate button again and use “+”/“–” to change the value in the display.

When the cooking time is finished

The oven will switch off and “End” will appear in the display. A warning signal will sound. Both of the lights next to the display will stop flashing.



- Press any selector button to stop the alarm buzzer.
The display will show the normal clock again. The oven starts again. (except when the roasting thermometer is inserted).
- Turn the temperature control and the mode selector switch to “0”.

Setting the cooking time \rightarrow (switch-off function)

The oven turns itself off when the pre-set time has elapsed.

- Press “ \rightarrow ”: the light will flash and “0.00” will appear in the display.

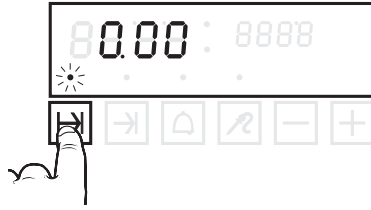

- Use “+”/“-” to set the cooking time in hours and minutes.



After approx. 3 seconds, the timer will start and the light will stay on continuously. The display will show the time remaining. Both lamps will flash alternately.



- Set the temperature and mode.

Setting the finish time \rightarrow (switch-off function)

Use this function if you want the oven to switch off automatically after a certain time.

- Press “ \rightarrow ”: the light will flash and display will show the normal clock.



- Use “+”/“-” to set the desired switch-off time.



After approx. 3 seconds, the timer will start and the light will stay on continuously. The display will show the time remaining. Both lights will flash alternately.



- Set the temperature and mode.

Automatic turn-on and shut-off

To use the oven's time-delay feature, you can pre-select both the cooking time and finish time. The automatic start time itself can't be specified. This is determined from both settings.

- ☞ It's impossible to set a finish time before the start time: you will hear a buzzer and the value in the display won't change. If you want to shorten the cooking time you have set, do it before you reset the finish time.

Example:

It is 8:00 a.m. and you wish to have your roast ready at 1:00 p.m. The roast needs to be cooked for 90 minutes.

Change the cooking time “ \rightarrow ” from 0.00 to 1.30. Then change the finish time “ \rightarrow ” from 9.30 a.m. to 1:00 p.m.

Once the times have been accepted, “Auto” will appear in the display and the oven will switch on at 11:30 a.m. and off at 1:00 p.m.

This is how to set the automatic switch-on and switch-off:

- Press “ \rightarrow ”: the lamp will flash and “0.00” will appear in the display.

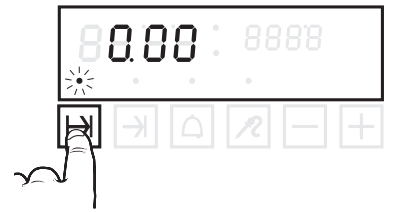

- Use “+”/“-” to set the cooking time in hours and minutes. (For example: 90 minutes)



- Press “ \rightarrow ” to confirm the input and select the finish time. The display will show a time (finish time if the oven is to switch on right away).

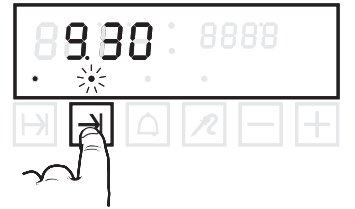

- Use “+” to set the finish time.

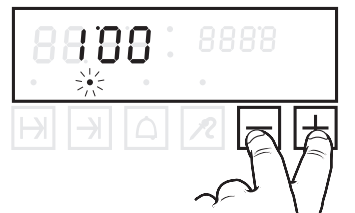

After approx. 3 seconds, the lights will stay on continuously. The display will show “Auto” until the oven switches on.



- Set the temperature and mode.

- The oven will automatically switch on at the specified time and both lights next to the display will flash alternately. The time remaining until switch-off will be shown in the display.



The roasting thermometer

The roasting thermometer measures the temperature inside the food. When the core temperature has reached a certain value, the roast is perfectly roasted – not too dry, or too bloody.

- ☞ We highly recommend using the roasting thermometer when preparing roasts whose core temperature must not exceed a certain value (i.e. roast beef).
- ☞ You can't enter a fixed cooking time – the cooking time depends on how long it takes for the temperature inside the roast to reach its final value. The cooking time can vary with the weight, type of meat, cooking temperature and mode.

Refer to the table "Recommended core temperatures" on page 14 for information about individual meals.

Please observe the following:

- Insert the tip of the roasting thermometer horizontally from the side right into the center of the food.
- Always insert the roasting thermometer into the roast up to the handle.
- The tip must not be located near the fat or the bone of the meat.
- When cooking poultry, don't touch any bones when inserting the roasting thermometer.

How to use the roasting thermometer

- Place the prepared roast with the inserted roasting thermometer into the oven.

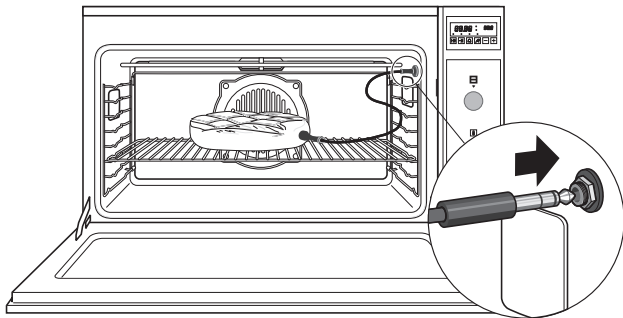

- Insert the plug of the roasting thermometer into the jack at the top right of the oven side wall.

The display on the right shows the current core temperature inside the roast:

The current core temperature inside the roast is displayed in the range from 95 °F / 35 °C to 203 °F / 95 °C. At temperatures below 95 °F / 35 °C you can see "-- °F", at temperatures above 203 °F / 95 °C the value "203 °F" flashes in the display.

In the left display you can see the preset temperature of 158 °F / 70 °C, which you can change.

- Close the oven door and set the core temperature function.

Setting the core temperature function

☞ This function will only work when the roasting thermometer is inserted. The right display shows you the current core temperature inside the roast and "158 °F" will appear in the left display. Both lamps will flash alternately.

- If you wish to change the preset temperature push "R" the lamp over "R" flashes.



- Change the the recommended temperature of 158 °F / 70 °C with "+" / "-" to set the desired temperature.

After approx. 3 seconds the timer will start and the light above the selector button will stay on continuously.

- Set temperature and mode. While roasting, the display on the right shows the current core temperature inside the roast.



When the actual core temperature reaches the value you have selected, the oven will switch itself off and "End" will appear in the display. A warning signal will sound. Both of the lights next to the display will stop flashing.

- Press any button to stop the alarm buzzer. As long as the roasting thermometer is inserted, you'll see two alternately flashing bars on the left side next to the temperatures.



- Turn the temperature control and the mode selector switch to "0".
- Remove the roasting thermometer from the socket. The display will show the normal clock again.

Core temperature function with delayed start

This allows you to delay the start of cooking when using the roasting thermometer. Since no fixed cooking time is set, you can't set a finish time.

☞ This function will only work when the roasting thermometer is inserted. The right display shows you the current core temperature inside the roast and "158 °F" will appear in the left display. Both lights will flash alternately.

- If you wish to change the preset temperature push "R" the lamp over "R" flashes.



- Change the the recommended temperature of 158 °F / 70 °C with "+" / "-" to set the desired temperature.

After approx. 3 seconds the timer will start and the lights will stay on continuously.

- "→" is held down to confirm the setting and the beginning of cooking time. The display shows you the current time.

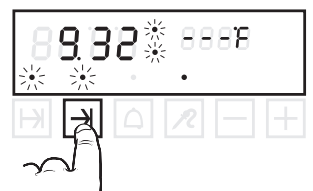
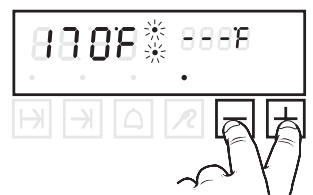

- Use "+" / "-" to set the start time.

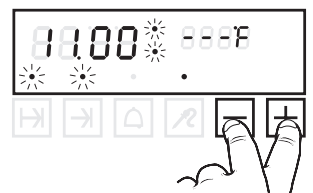

After approx. 3 seconds, the timer will start and the lights will stay on continuously. The display will show "Auto" until the oven switches on. The right display shows you the current core temperature inside the roast.



- Set the temperature and mode.
- The oven automatically switches on at the beginning of the cooking time. Both lights will flash alternately.



When the actual core temperature reaches the value you have set, the oven will switch itself off and "End" will appear in the display. A warning signal will sound. Both lights will stop flashing.



- Press any button to stop the alarm buzzer. Both lights will flash alternately in the display as long as the roasting thermometer is inserted.
- Turn the temperature control and the mode selector switch to "0".
- Remove the roasting thermometer from the socket. The display will show the normal clock again.



Recommended core temperatures

Dish	Core temperature	
	in °F	in °C
Beef		
Roast beef/Fillet of beef, rare	105-115	40-45
Roast beef/Fillet of beef, medium	120-130	50-55
Roast beef/Fillet of beef, well done	140-150	60-65
Joint of beef	175-185	80-85
Pork		
Loin of pork	150-160	65-70
Roast pork/ham	175-185	80-85
Neck, knuckle of pork	175-185	80-85
Chop, saddle	165-175	75-80
Chop without the bone	160	70
Smoked loin of pork	150-160	65-70
Meat loaf	160-165	70-75
Veal		
Roast veal	160-165	70-75
Roast veal stuffed with kidneys	165-175	75-80
Knuckle of veal	175-185	80-85
Game		
Meat of game	165-175	75-80
Saddle	140-160	60-70
Fillet of game, rare	105-115	40-45
Fillet of game, medium	120-130	50-55
Fillet of game, well done	140-150	60-65
Lamb		
Lamb	175-185	80-85
Stuffed joint	160-165	70-75
Poultry	185-195	85-90
Fish	160-175	70-80

Cleaning and care

Carefully read this chapter before you use your appliance for the first time. With correct cleaning and regular maintenance, the appliance will remain beautiful and clean for many years. These tips will help you maintain and keep the individual surfaces clean.

For all surfaces

- ⚠ Don't use steam and/or pressure cleaning machines to clean the appliance! This can damage the unit and risk **personal injury**.
- ⚠ **Risk of burning!** Make sure the appliance has cooled down before cleaning.
- ⚠ Please pay attention to the cleanser's instructions.

Clean the appliance after each use. Dirt that hasn't been removed will burn into the surface the next time the oven is turned on, making it virtually impossible to remove these incrustations.

Use a damp cloth or a soft sponge with a mixture of warm water and mild detergent to clean surface dirt. Use cold water to wipe off the surface completely and to remove residues from cleansers which can cause discoloration and stains. Wipe dry.

☞ To remove heavy dirt and clean individual parts and surfaces, read on.

Don't use:

- aggressive or bleaching cleansers with active oxygen, chlorine or corrosive components.
- abrasive or aggressive cleansers or scouring agents like steel wool, soap-filled steel wool, metal or plastic sponges or similar items with an abrasive surface.

Remove caking

Soak heavy dirt with a wet cloth, to make it easier to clean.

Using a cleaning scraper

- ⚠ Caution! The blade of the cleaning scraper is very sharp. Be careful when using!

Always keep the cleaning scraper flat on the surface and push the caked-on debris away from you.

- ⚠ Don't scratch the surface with the edge of the scraper or damage the sealing with the scraper's edge.

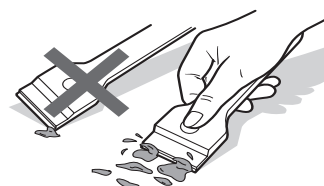

Information about oven sprays

- ⚠ Please follow the manufacturer's instructions. Oven sprays damage aluminium, lacquered surfaces and plastic!
- ⚠ Don't spray into the opening of the ventilator at the backplate!

For environmental reasons, we do not recommend the use of oven sprays. If you do use one, only use it in the oven interior and on enamel baking trays.

Enamel

Oven interior, front, baking trays, drip pan

It's okay to use some plastic sponges with an abrasive side. However, some products do contain grains in the abrasive side of the sponge which can cause scratches. Carefully test the sponge on a small surface!

- ☞ Use a cleaning scraper for glass ceramic surfaces to remove heavy dirt.
- ☞ Oven spray may be used - however not on an enamel cook top.

Stainless steel

Stainless steel door front, control panel, telescopic glide-out shelves (acc. No. 601)

- ⚠ Stainless steel is easily scratched! **Do not use a cleaning scraper!**
- ⚠ To avoid stains, remove calcium deposits, grease or starch as soon as possible.

A stainless steel cleanser can be effective.

Clean all stainless steel surfaces weekly with a stainless steel cleanser. This will create a protective film, which will protect the stainless steel surface from discoloration.

Glass

Inside of the door – coated glass

- ⚠ Don't use oven spray. It can destroy the coated glass surface.
- Use a cleaning scraper for glass ceramic surfaces to remove heavy dirt.

Door front, control panel

- ☞ Clean the front of the oven, by using a damp cloth or soft sponge with a mixture of warm water and mild detergent. You may use glass cleaning agents.

Buttons

Clean the buttons with a mixture of warm water and mild detergent, with a damp cloth or soft sponge.

Removing and installing the oven door

Removing the oven door

- Open the oven door as wide as possible.
- Fold up the clamps on the door hinges.

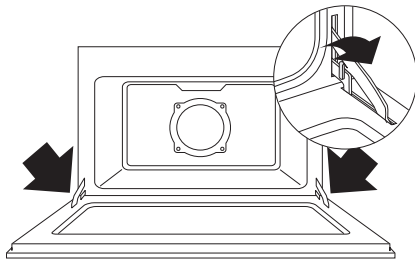

- Grab the oven door on both sides and close it slowly. When the oven door is about half-closed, the hinges will fall out of the catches. The oven door can now be removed.

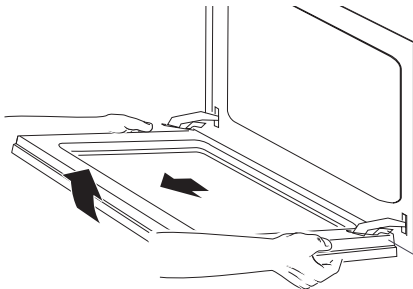

Reassembling the oven door

- Grab the oven door on both sides and push the hinges into the appropriate holes on the oven.
- Slowly open the oven door.
- Fold down the clamps on the door hinges.
- Close the oven door.

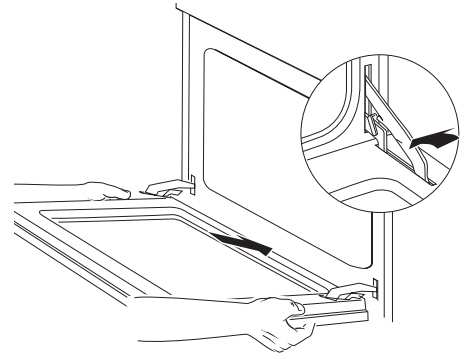

Removing and installing the side racks

Removing the side racks

- Loosen the screws.
- Remove the slot-in racks.

Installing side racks

- Insert side racks and tighten down in front.

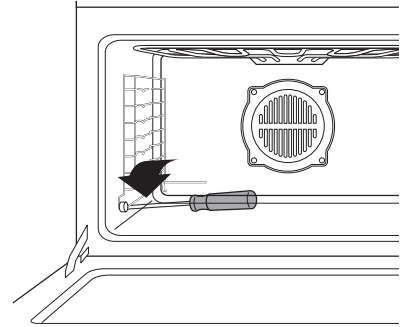

Folding heating element down/up

Folding heating element (top heat/grill) down

- Open lock and fold heating element down.

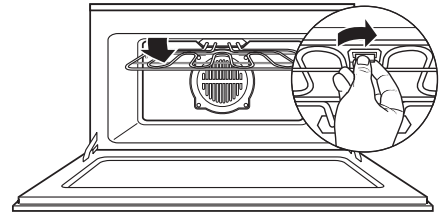

Folding heating element up

- Fold heating element up and close again with the lock.

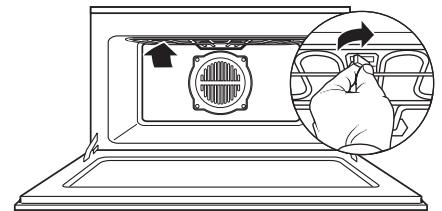

Unscrewing/reinstalling the individual telescopic glide-out shelves (acc.-no. 601)

Unscrewing the individual telescopic glide-out shelves

If you want, you can screw the individual telescopic glide-out shelves off the side walls with a screwdriver so that it is easier to clean the walls

- For this purpose unscrew the bottom holding screw on each side.

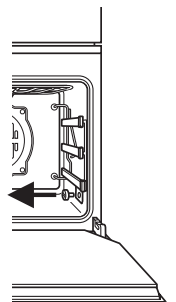

Reinstalling the individual telescopic glide-out shelves

- Insert the individual telescopic glide-out shelves at the back into the holes in the intermediate wall and screw the individual telescopic glide-out shelves at the bottom front to the side walls.

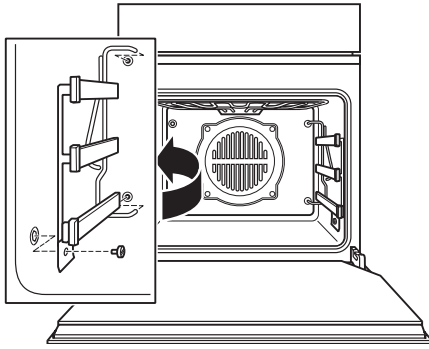

Regenerating the ökotherm[®] catalyst

- Set the mode selector to Hot air convection .
- Set temperature control to “▼▼”.
- Heat the empty oven for 60 minutes.

What to do if trouble occurs...

⚠ Use a qualified technician for repairs!

However, there are some problems you can handle yourself. First, check and see if there have been any operating errors. Remember – repairs during the guarantee period are not free of charge if they are caused by operating errors or non-observance of the following instructions.

Fault	Cause	Remedy
Clock flashes "0.00" and the oven doesn't work .	The clock isn't set: this can happen during startup or after power has been interrupted.	Set the clock. (p. 5)
Can't turn off the oven.	Defective electronic component.	Disconnect fuse, call Customer Service.
Oven doesn't heat up.	Defective fuse.	Check and replace fuse, if necessary.
	Temperature control or mode selector has not been switched on.	Set temperature control or mode selector as required.
Oven light no longer works.	Defective lighting.	Ask Customer Service about changing the light bulb.
Mode display or heating-up display does not light up.	Defective lighting.	Have Customer Service replace light.
Glass of oven door is broken.		Switch off the appliance, call Customer Service.
Strong smells from oven in spite of ökotherm [®] catalyst.	ökotherm [®] catalyst must be regenerated.	See page 15.
Strong vinegar smell when preparing food.	Sour doughs, yeast doughs, recipes with alcohol.	Odors are unavoidable.
Fruit juice or protein stains on enamelled parts.	Moist cake or meat juices.	Harmless changes in the enamel, can't be remedied.
Display of the roasting thermometer indicates "-- °F" or "203 °F" (flashing).	Temperature is outside the display range.	See page 13 "The roasting thermometer".
"Err 1" appears in the display.	Roasting thermometer defective.	Replace roasting thermometer with one available through Customer Service! You can use the oven without the core temperature feature.
	Socket defective.	Have the socket checked out.

Replacing a halogen bulb

⚠ Attention! The halogen bulb becomes very hot after being in use for a while. Don't change the bulbs until they have cooled down.

⚠ Only replace the halogen bulbs with identical bulbs. You can get new halogen bulbs from KÜPPERSBUSCH Customer Service.

☞ Don't hold the halogen bulbs with your bare hands. Finger marks burn into the bulb glass and reduce the light intensity and service life of the bulbs.

Changing the halogen lamp:

– Unscrew the shelf rack.

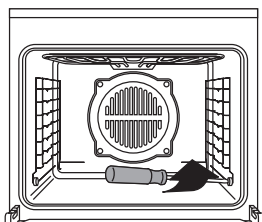

– Carefully lever out the glass cover with a screwdriver.

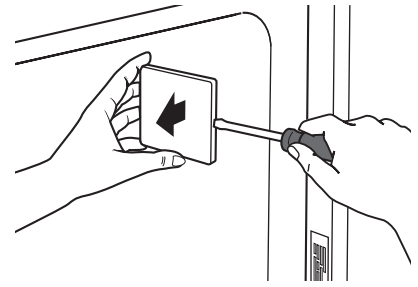

– Remove the halogen bulb from its socket.

– Hold the new bulb **with a cloth** (i.e. tissue) and push it into the socket.

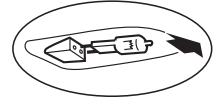

– Reinstall the glass cover.

– Screw the shelf rack on again.

After Sales Service

In the event of a problem that you can't easily fix yourself, or for spare part service, please contact the Küppersbusch Customer Care line at

1-800-459-0844

☞ Always have the information from the identification panel handy when calling Customer Service.

The rating label for the oven is located on the right-hand side strip and is visible when the oven door is open.

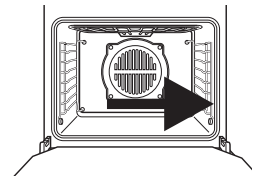

– Make a note of this information in case you have to consult our customer service.

Production-no. oven											

Model designation oven											

Model

Production number

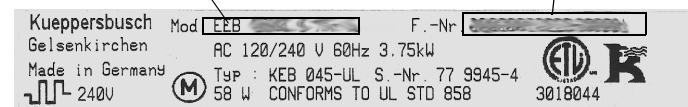

KÜPPERSBUSCH

112 N. East Street, Suite C

Tampa, Florida 33602

Telephone: 813-229-7096 Fax: 813-229-0982

Customer Care line: 1 - 800 - 459 - 0844

www.kuppersbuschusa.com

KÜPPERSBUSCH is a brand of Teka USA, Inc.

Küppersbusch

THE HEART OF A GOOD KITCHEN