

Obsolated by 550-110-638/0196

# WEIL-McLAIN

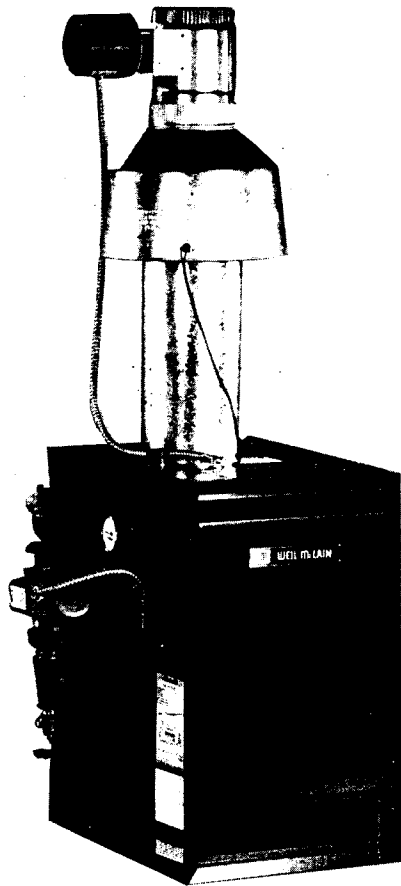

## CG (Series 11) and CGX (Series 1) Gas-Fired Boilers



### Boiler Manual

#### Includes:

- Installation
- Start-up
- Service
- Boiler Parts

Refer to Control Supplement  
for additional information  
and Gas Control Parts

For Natural or Propane Gas

### BOILER MANUAL FOR USE BY A QUALIFIED CONTRACTOR

To the owner: Regular service on this boiler is recommended and should be performed by a qualified contractor.

To the installer: Read all instructions and warranty before starting.

Any claims for damage or shortage in shipment must be filed immediately  
against the transportation company by the consignee.

Part No. 550-110-630/0695DCP



# Table of Contents

## Section I: Pre-Installation

Air Supply for Combustion .....	3
Chimney or Vent Requirements .....	3
Minimum Service Clearances .....	4
Boiler Foundation .....	4

## Section II: Boiler Set-Up

Placement .....	5
Draft Hood .....	5
Breeching .....	5
Hydrostatic Pressure Test .....	5

## Section III: Piping

Supply and Return .....	6
Expansion Tank Sizing .....	6
Multiple Zoning with Circulators .....	7
Bypass Piping .....	8
Use with Refrigeration System .....	8

## Section IV: Gas Piping ..... 9

## Section V: Wiring ..... 10

## Section VI: Final Adjustments ..... 11 – 12

## Section VII: Check-Out Procedure ..... 13

## Section VIII: Maintenance ..... 14 – 15

## Section IX: Replacement Parts ..... 16 – 21

## Ratings & Dimensions ..... 22 – 23

**IMPORTANT:** When calling or writing about boiler, **PLEASE GIVE MODEL and SERIES** located on boiler rating label **AND C.P. NUMBER** affixed next to rating label.

The following defined terms are used throughout this manual. They bring attention to presence of hazards of various risk levels, or to important information concerning life of product.

### DANGER

Indicates presence of a hazard which will cause severe personal injury, death or substantial property damage if ignored.

### CAUTION

Indicates presence of a hazard which will or can cause minor personal injury or property damage if ignored.

### WARNING

Indicates presence of a hazard which can cause severe personal injury, death or substantial property damage if ignored.

### NOTICE

Indicates special instructions on installations, operation, or maintenance which are important but not related to personal injury hazards.

### DANGER

Do not use petroleum based cleaning or sealing compounds in boiler system. Severe damage to boiler will result, causing substantial property damage.

### WARNING

Read all instructions before installing.  
Failure to follow all instructions in proper order can cause severe personal injury, death, or substantial property damage.



## Section I: Pre-Installation

### CODES

Installation must comply with all local codes, laws, regulations and ordinances, also National Fuel Gas Code ANSI Z223.1-latest edition. When required, installation must conform to Standard for Controls and Safety Devices for Automatically Fired Boilers, ANSI/ASME CSD-1. Safe lighting and other performance criteria were met with the gas manifold and control assembly provided on boiler when boiler underwent tests specified in ANSI Z21.13-latest edition.

Canadian installations must comply with CAN/CGA B149.1 or .2 Installation Codes.

### COMBUSTION AIR AND VENTILATION OPENINGS

Combustion air and ventilation openings must comply with Section 5.3, Air for Combustion and Ventilation, of National Fuel Gas Code ANSI Z223.1-latest edition, or applicable local building codes. Canadian installations must comply with CAN/CGA B149.1 or .2 Installation Codes.

#### WARNING

Adequate combustion air and ventilation openings must be provided to assure proper combustion, prevent possibility of flue gas spillage and carbon monoxide emissions, causing severe personal injury or death.

Boiler installation must assure sufficient openings in building and boiler room to provide adequate combustion air and ventilation. Consider construction tightness of building when deciding whether additional outside openings may be needed.

Older buildings with single-pane windows, minimal weather-stripping and no vapor barrier often provide enough natural infiltration and ventilation without dedicated openings.

New construction or remodeled buildings are most often built tighter. Windows and doors are weatherstripped, vapor barriers are used and openings in walls are caulked. As a result, such tight construction is unlikely to allow proper natural air infiltration and ventilation.

Air from inside building (boiler in interior room):

- Tightly constructed buildings must be provided with openings to outside for combustion and ventilation air. These openings must be sized to handle all fuel burning appliances, exhaust and ventilation fans and fireplaces.
- When openings to boiler room are taken to interior spaces, provide two permanent openings: a combustion air opening within 12 inches of floor and a ventilation opening within 12 inches of ceiling. Each opening must provide a minimum free area of one square inch per 1,000 Btuh input of all appliances in room plus requirements for any exhaust fans in room. The interior space supplying combustion and ventilation air must have adequate infiltration from outside.

Air directly from outside to boiler room:

- Tightly constructed buildings must be provided with combustion air and ventilation openings to boiler room which are adequate to handle the boiler needs plus the needs of all other fuel-burning appliances, fireplaces and exhaust or ventilation fans.
- Combustion and ventilation openings connecting directly or by ducting to outside, or to attic or crawl spaces that freely connect with outside, must be sized as follows:
  1. Outside wall or vertical ducting – one square inch per 4,000 Btuh input of all appliances in room plus requirements for any exhaust fans or other appliances in room.

2. Horizontal ducting – one square inch per 2,000 Btuh of all appliances in room plus requirements for any exhaust fans or other appliances in room.
3. All ducting must be same size as permanent openings. Minimum area dimensions of ducting must be no less than 9 square inches.
4. Other size ducting must comply with local codes.

### CHIMNEY OR VENT REQUIREMENTS

Venting must be installed according to Part 7, Venting of Equipment, of National Fuel Gas Code, ANSI Z223.1-latest edition and applicable building codes. Canadian installations must comply with CAN/CGA B149.1 or .2 Installation Codes.

Minimum chimney or vent sizes are on page 23 of these instructions. A chimney or vent should extend at least 3 feet above the highest point where it passes through a roof of a building and at least 2 feet higher than any portion of a building within a horizontal distance of 10 feet. A chimney or vent must not extend less than those distances stated above.

A lined chimney is preferred and must be used when required by federal, provincial, territorial, state, or local building codes. Vitreous tile linings with joints that prevent retention of moisture and linings made of noncorrosive materials are best. Advice for flue connections and chimney linings can be obtained from local gas utility. Type "B" vent material or single wall vent pipe may be used.

Cold masonry chimneys, also known as outside chimneys, typically have one or more walls exposed to outside air.

When any atmospheric gas-fired boiler with automatic vent damper is vented through this type of chimney, the potential exists for condensation to occur. Condensation can damage a masonry chimney.

Weil-McLain recommends the following to prevent possible damage:

1. Line chimney with corrosion-resistant metal liner such as AL29-4C® single wall stainless steel or B-vent. Size liner per National Fuel Gas Code ANSI Z223.1-latest edition.
2. Provide drain trap to remove any condensate.

#### DANGER

Inspect existing chimney before installing boiler. Failure to clean or replace perforated pipe or tile lining will cause severe injury or death.

#### DANGER

Do not alter boiler draft hood or place any obstruction or non-approved damper in breeching or vent system. A.G.A./CGA certification will become void. Flue gas spillage and carbon monoxide emissions will occur causing severe personal injury or death.

Where two or more gas appliances vent into a common chimney or vent, equivalent area should be at least equal to area of vent outlet on largest appliance plus 50 percent of vent outlet area on additional appliance.

### WHEN REMOVING BOILER FROM COMMON VENTING SYSTEM:

#### WARNING

Failure to follow all instructions listed below can cause flue gas spillage and carbon monoxide emissions, resulting in severe personal injury, death or substantial property damage.



At the time of removal of an existing boiler, the following steps shall be followed with each appliance remaining connected to the common venting system placed in operation, while the other appliances remaining connected to the common venting system are not in operation.

- Seal any unused openings in the common venting system.
- Visually inspect the venting system for proper size and horizontal pitch and determine there is no blockage or restriction, leakage, corrosion and other deficiencies which could cause an unsafe condition.
- Insofar as is practical, close all building doors and windows and all doors between the space in which the appliances remaining connected to the common venting system are located and other spaces of the building. Turn on clothes dryers and any appliance not connected to the common venting system. Turn on any exhaust fans, such as range hoods and bathroom exhausts, so they will operate at maximum speed. Do not operate a summer exhaust fan. Close fireplace dampers.
- Place in operation the appliance being inspected. Follow the lighting instructions. Adjust thermostat so appliance will operate continuously.
- Test for spillage at the draft hood relief opening after 5 minutes of main burner operation. Use the flame of a match or candle, or smoke from a cigarette, cigar or pipe.
- After it has been determined that each appliance remaining connected to the common venting system properly vents when tested as outlined above, return doors, windows, exhaust fans, fireplace dampers, and any other gas-burning appliance to their previous conditions of use.
- Any improper operation of the common venting system should be corrected so the installation conforms with the National Fuel Gas Code, ANSI Z223.1 – latest edition. When resizing any portion of the common venting system, the common venting system should be resized to approach the minimum size as determined using the appropriate tables in Appendix G in the National Fuel Gas Code, ANSI Z223.1-latest edition.

Canadian installations must comply with CAN/CGA B149.1 or .2 Installation Codes.

### SELECT THE BOILER LOCATION

- Consider all connections to boiler before selecting a location.
- Boiler must be installed so that gas control system components are protected from dripping or spraying water or rain during operation or service.

#### WARNING

To avoid personal injury, death or property damage, keep boiler area clear and free from combustible materials, gasoline and other flammable vapors and liquids.

### INSTALLATION CLEARANCES

#### Suggested for easy servicing:

- 24 inches for cleaning and servicing, left side.
- 18 inches for access to controls and components, front.
- 35 inches from top for cleaning flueways.
- 7 inches on remaining sides.

Screwdriver clearance for removal of jacket screws should be provided. If not, unions and shut-off valves should be installed in system so boiler can be moved for servicing.

#### Required clearances to combustible material for closet installations

- |         |            |          |
|---------|------------|----------|
| Top 35" | R. Side 2" | Front 3" |
| Rear 7" | L. Side 6" |          |

Hot water pipes must be at least 1/2 inch from combustible material.

Single wall vent pipe must be at least 6 inches from combustible material.

Double wall vent pipe refer to vent manufacturer's recommendation for clearances to combustible material.

### RESIDENTIAL GARAGE INSTALLATION

Install boiler so burners are at least 18 inches above the floor.

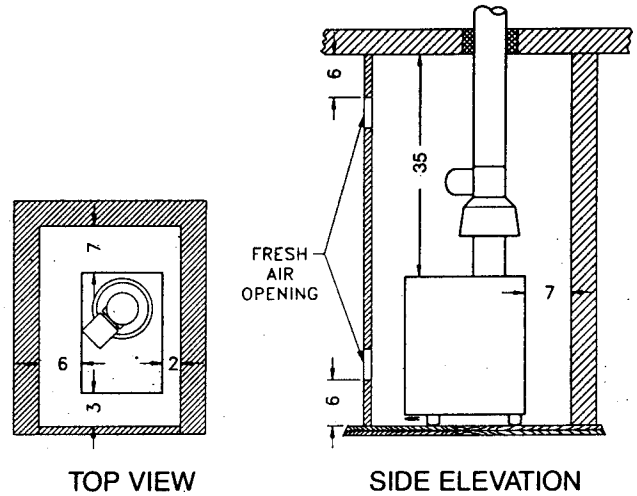

FIGURE 1

### BOILER FOUNDATION

Boilers are approved for use on combustible flooring but must not be installed on carpeting.

#### WARNING

Do not install boiler on carpeting even if foundation is used. Fire can result causing severe personal injury, death or substantial property damage.

- Level concrete or solid brick pad foundation is required if:
  - Water could flood area.
  - Non-level conditions exist.

BOILER FOUNDATION SIZES	
Boiler Size	Foundation Width
25, 3	12"
4	15"
5	18"
6	21"
7	24"
8	27"

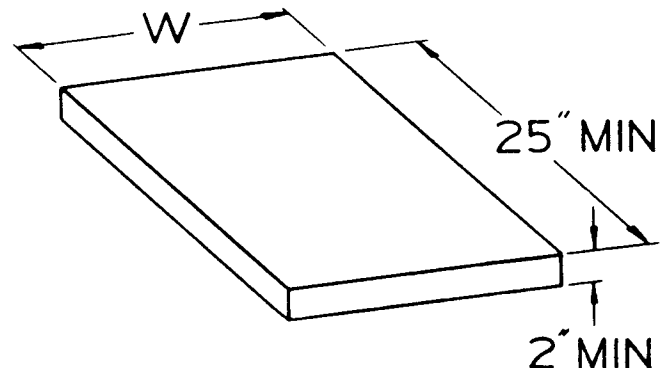

BOILER FOUNDATION  
FIGURE 2



## Section II: Boiler Set-up

### PLACING THE BOILER.

Leave boiler in crate and on pallet until installation site is ready.

1. Move entire crate and pallet next to selected location.
2. Remove crate.
3. Remove boiler from pallet as follows:
  - a. Tilt left side of boiler up and place a board under left legs.
  - b. Tilt boiler the other way and place a board under right legs.
  - c. Slide boiler backward off pallet and into position.

**DO NOT DROP BOILER OR BUMP JACKET ON FLOOR OR PALLET.**

4. Check level. Shim legs, if needed. Do not alter legs.
5. Remove front jacket door. Remove base access panel (CG models only).
6. Check for proper orifice sizing from chart below.

#### DANGER

Proper orifices must be used. Failure to do so will cause severe injury, death or substantial property damage.

CG Series 11 – ORIFICE SIZES		
Type of Gas	Heating Value, BTU/cu. ft.	Orifice Size
Natural	1000	2.0mm
Propane	2500	1.3mm
ORIFICE SIZE – CANADA ONLY		
Elevation	Natural	Propane
0 – 2000 ft.	2.0mm	1.3mm
2000 – 4500 ft.	1.9mm	1.2mm

CGX Series 1 – ORIFICE SIZES		
Type of Gas	Heating Value, BTU/cu. ft.	Orifice Size
Natural	1000	#35 Drill
ORIFICE SIZE – CANADA ONLY		
Elevation	Natural	Propane
0 – 2000 ft.	#35 Drill	N/A
2000 – 4500 ft.	#37 Drill	N/A

7. Level and straighten burners (CG models only).

#### DANGER

Burners must be properly seated in slots in burner rest with their openings face up. Main burner orifices must inject down center of burner. Failure to properly seat burners will result in severe personal injury, death or substantial property damage.

8. Reinstall access panel (CG models only).

#### CAUTION

Access panel must be secured in position during boiler operation to prevent momentary flame rollout on ignition of main flame.

### HYDROSTATIC PRESSURE TEST

Pressure test before attaching piping or electrical supply.

1. Remove shipping nipple from supply outlet. Remove relief valve. Plug tappings, including compression tank tapping and relief valve opening.
2. Connect water supply. Fill boiler and purge all air. Test at 1½ times working pressure.

#### WARNING

Do not leave boiler unattended. A cold water fill could expand and cause excessive pressure, resulting in severe personal injury, death or substantial property damage.

3. Check for maintained gauge pressure for more than 10 minutes.

#### WARNING

Leaks must be repaired at once. Failure to do so can damage boiler, resulting in substantial property damage.

#### DANGER

Do not use petroleum based cleaning or sealing compounds in boiler system. Severe damage to boiler will result, causing substantial property damage.

4. Drain boiler and repair leaks if found. Remove testing plugs. Reinstall relief valve, with spindle in vertical position.

### DRAFT HOOD INSTALLATION

Secure draft hood to outlet at top of boiler with sheet metal screws. Bottom of draft hood or "skirt" must have clearance dimension above jacket top panel as indicated on draft hood.

#### DANGER

Do not alter boiler draft hood or place any obstruction or non-approved damper in breeching or vent system. A.G.A./CGA certification will become void. Flue gas spillage and carbon monoxide emissions will occur causing severe personal injury or death.

### SPILL SWITCH INSTALLATION

Fasten spill switch to draft hood as shown on page 17. Connect wires as shown in Control Supplement.

### DAMPER INSTALLATION

See Control Supplement for information.

### BREECHING ERECTION

Connect from draft hood or damper outlet to chimney or vent with same size breeching. Where possible, vertical venting to the outside from the draft hood or damper outlet will offer best performance. Where horizontal breeching is used, slope upward at least ¼ inch per lineal foot toward chimney or vent and support with hangers to prevent sagging.

#### WARNING

Long horizontal breechings, excessive numbers of elbows or tees, or other obstructions which restrict the flow of combustion gases should be avoided.

Breeching must not be connected to any portion of a mechanical draft system that can operate under positive pressure.

#### CAUTION

Failure to properly pipe boiler may result in improper operation and damage to boiler or building.



## Section III: Piping

1. Pipe as shown in Figures 3 or 4.
  - a. Diaphragm-type expansion tank: Be sure tank pressure and size will handle system pressure and water volume.
    - 1) Fill pressure may be adjusted at tank for design conditions. Follow manufacturer's instructions.
    - 2) Additional tanks may be connected to tees in system near boiler.
    - 3) Install automatic air vent as shown in Figure 3.
  - b. Closed-type expansion tank: Size tank to system requirements. Refer to tank manufacturer's instructions.
    - 1) Connect from 1/2" N.P.T. tapping (located behind supply outlet) to expansion tank. Use 1/2" piping. Any horizontal piping must pitch up towards tank 1" per 5 feet of piping.
    - 2) Built-in air elimination system is provided. No additional device is needed if tank is piped as shown in Figure 4.
2. Use low water cut-off when:
  - a. boiler is located above radiation level.
  - b. required by certain state, local, or territorial codes or insurance companies.

Use low water cut-off designed for water installations. Electrode probe type may be located in tee in supply piping.

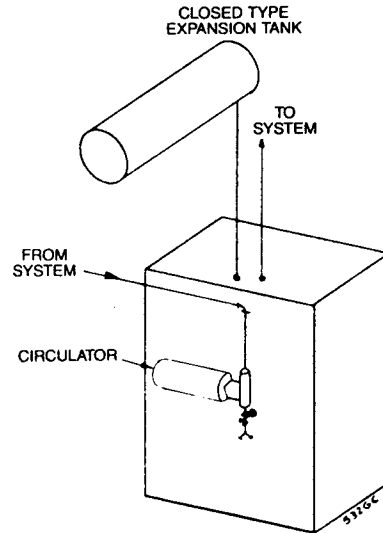

**CLOSED TYPE EXPANSION TANK PIPING  
FIGURE 4**

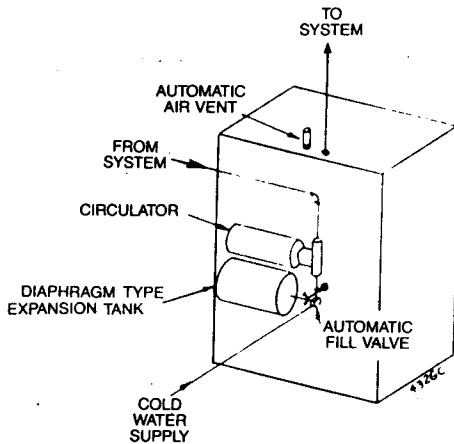

**DIAPHRAGM TYPE  
EXPANSION TANK PIPING  
FIGURE 3**

**TABLE I - MINIMUM RECOMMENDED PIPE SIZES**

Boiler Size	Supply	Return
25	3/4"	3/4"
3	1"	1"
4	1"	1"
5	1"	1"
6	1 1/4"	1 1/4"
7	1 1/4"	1 1/4"
8	1 1/2"	1 1/2"

Based on 20°F temperature drop between supply and return.

3. If the system is to comply with ASME or Canadian requirements, an additional high temperature limit is needed. Install control in supply piping between boiler and isolation valve. Set second control to minimum 20°F above set point of first control. Maximum allowable set point is 240°F. See Control Supplement for wiring.
4. Verify relief valve is installed with spindle in vertical position.

**WARNING**

Relief valve discharge piping must be piped near floor close to floor drain to eliminate potential of severe burns. Do not pipe to any area where freezing could occur.

5. Connect supply, return, and cold water fill piping. See Table I for minimum recommended pipe sizes.

## MULTIPLE ZONING WITH CIRCULATORS

1. If multiple zoning with circulators, remove provided circulator. See Figure 5:
  - a) Determine if by-pass piping will be needed. See page 8.
  - b) Mount circulators as shown.
  - c) Install flow control valves.
  - d) Follow remaining piping instructions.
  - e) Size common supply and return piping for combined flow of all circulators.

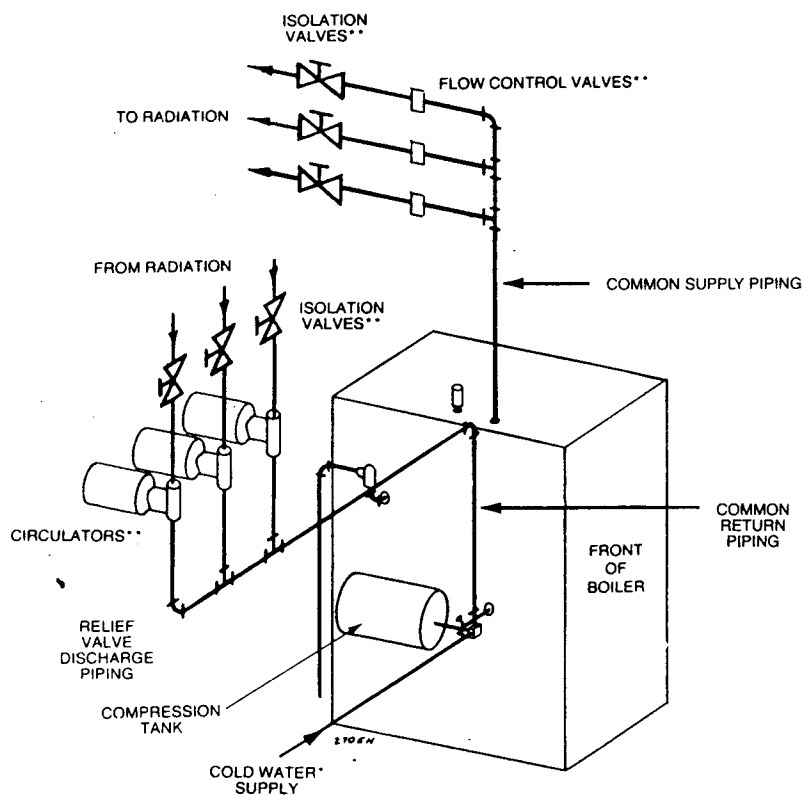

\*DO NOT USE DRAIN COCK TAPPING  
 \*\*MAY BE INSTALLED IN ALTERNATE LOCATIONS

MULTIPLE ZONING WITH CIRCULATORS  
 FIGURE 5



## BYPASS PIPING

BYPASS PIPING IS NOT NORMALLY REQUIRED ON TYPICAL BASEBOARD SYSTEM.

Bypass piping should be used for the following installations. Bypass, supply, and return piping should be same size.

1. To protect:

- radiant panels, plaster, etc. from high temperature water supplied from boiler, or
- boiler from condensation caused by low temperature water returned from system.

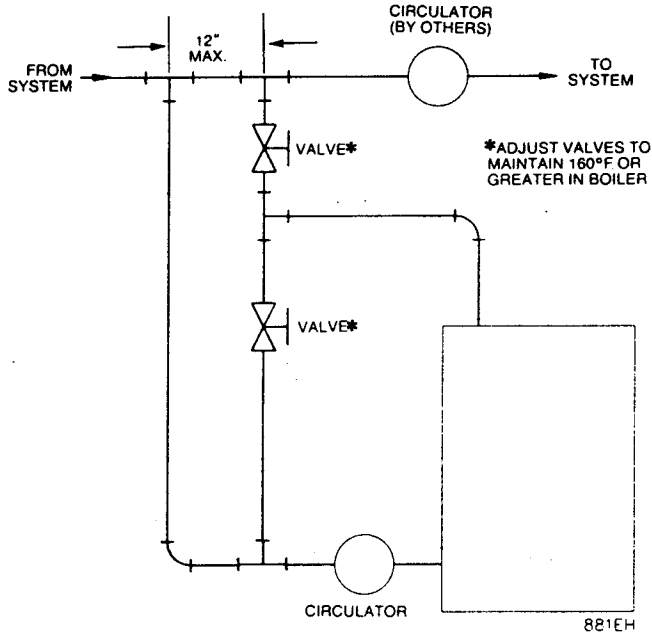

FIGURE 6

2. To protect boiler from condensation formed by low water temperature returned from large water content converted gravity systems, etc., see Figure 7.

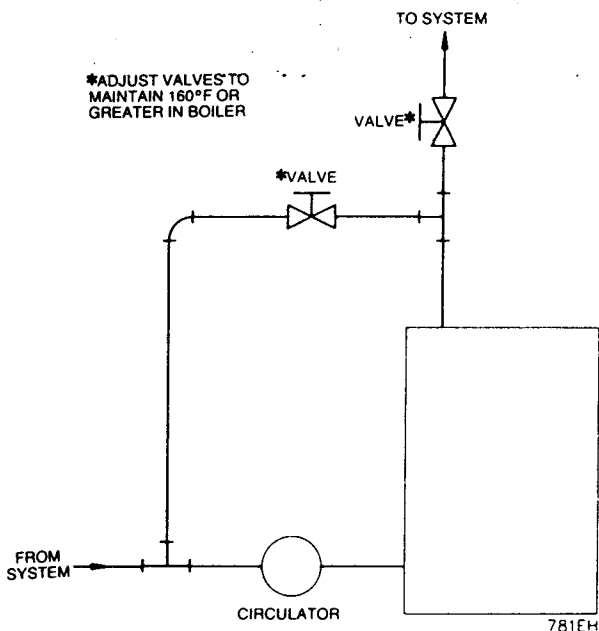
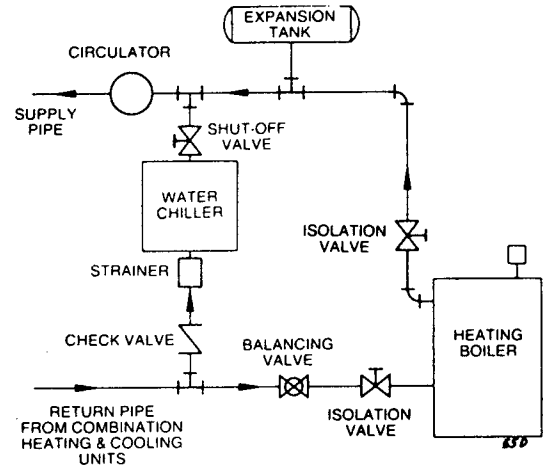

FIGURE 7

## USE WITH REFRIGERATION SYSTEM

Boiler must be installed so that chilled medium is piped in parallel with heating boiler using appropriate valves to prevent chilled medium from entering boiler. Consult I=B=R Installation and Piping Guides.

If boiler is connected to heating coils located in air handling units where they can be exposed to refrigerated air, gravity circulation during cooling cycle must be prevented with flow control valves or other automatic means.



RECOMMENDED PIPING FOR COMBINATION HEATING & COOLING (REFRIGERATION) SYSTEMS  
FIGURE 8



## Section IV: Gas Piping

Size gas piping considering:

- a. Diameter and length of gas supply piping.
  - b. Number of fittings.
  - c. Maximum gas consumption (including any possible future expansion).
  - d. Allowable loss in gas pressure from gas meter outlet to boiler. For pressure drops, see ANSI Z223.1-latest edition. Canadian installations must comply with CAN/CGA B149.1 or .2 Installation Codes.
1. For natural gas:
    - a) Refer to following tables. To obtain cubic feet per hour, divide the input by 1000.
    - b) Size for rated boiler input.
    - c) Inlet gas pressure: 5" W.C. minimum  
13" W.C. maximum
    - d) Manifold gas pressure: 3½" W.C.
    - e) Install 100% lock-up gas pressure regulator in supply line if inlet pressure exceeds 13" W.C. Adjust for 13" W.C. maximum.

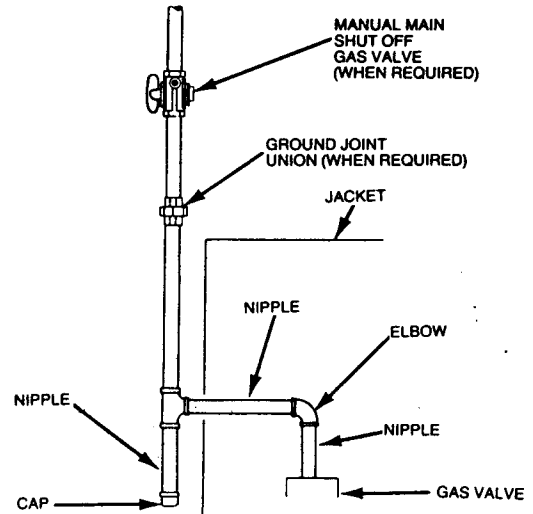

**GAS SUPPLY PIPING  
FIGURE 9**

### PIPE DELIVERY SCHEDULE

Length of Pipe in Feet	*CAPACITY OF PIPE IN CUBIC FEET OF GAS PER HOUR				
	½"	¾"	1"	1¼"	1½"
10	132	278	520	1050	1600
20	92	190	350	730	1100
30	73	152	285	590	890
40	63	130	245	500	760
50	56	115	215	440	670
75	45	93	175	360	545
100	38	79	150	305	460
150	31	64	120	250	380

\* 0.60 Specific Gravity, 0.30 inches water column pressure drop.  
NOTE: For additional piping schedules, see ANSI Z223.1-latest edition. Canadian installations must comply with CAN/CGA B149.1 or .2 Installation Codes.

2. For propane gas:
  - a) Inlet gas pressure: 11" W.C. minimum  
13" W.C. maximum
  - b) Manifold gas pressure: 10" W.C.
  - c) Gas pressure regulator provided by gas supplier must be adjusted for maximum pressure of 13" W.C.
  - d) Contact gas supplier to size pipes, tanks and regulator.
3. Remove jacket door and refer to Figure 9 for gas piping.
4. Follow good piping practices.
5. Pipe joint compound (pipe dope) must be resistant to corrosive action of liquified petroleum gases and applied sparingly only to male threads of pipe joints.

6. Install drip leg at inlet of gas connection to boiler. When local utility requires drip leg be extended to the floor, use appropriate length of pipe between cap and tee.
7. Install ground joint union to provide for servicing, when required.
8. Install manual shut-off valve in gas supply piping outside boiler jacket when required by local codes or utility requirements.
9. Support piping by hangers, not by boiler or its accessories.
10. Purge all air from supply piping.
11. Before placing boiler in operation, check boiler and gas connection for leaks.

### WARNING

Do not check for gas leaks with an open flame – use bubble test. Failure to do so can cause severe personal injury, death or substantial property damage.

- a) Close manual main shut-off valve during any pressure testing at less than 13 inches water column.
  - b) Disconnect boiler and gas valve from gas supply piping during any pressure test greater than 13 inches water column.
12. In Canada – when using manual main shutoff valve, must be identified by installer.



## Section V: Wiring

**Refer to wiring diagram label on jacket door and Control Supplement for specific wiring details.**

### WARNING

#### WIRING

For your safety, turn off electrical power supply at service entrance panel before making any electrical connections to avoid possible electrical shock hazard.

All wiring must be installed in accordance with requirements of National Electrical Code and any additional national, state, or local code requirements having jurisdiction. All wiring must be N.E.C. Class 1. Boiler must be electrically grounded in accordance with the National Electrical Code, ANSI/NFPA No. 70-latest edition.

In Canada, installation must conform to CSA C22.1 Canadian Electrical Code Part 1 and any local codes.

If original rollout thermal fuse element wire as supplied with boiler must be replaced, type 200°C wire or equiv. must be used. If other original wiring as supplied with boiler must be replaced, type 105°C wire or equivalent must be used.

Boiler is shipped with control components completely wired, except spill switch and damper.

Separate electrical circuit with fused disconnect switch (15 amp. recommended) should be used for boiler. Bring electrical supply through proper opening in jacket left end panel and into electrical junction box. Wire electrical supply to leads in junction box as shown on diagram.

#### INSTALL ROOM THERMOSTAT

Install room thermostat on an inside wall. Never install where it will be influenced by drafts, hot or cold water pipes, lighting fixtures, television, sun rays or near a fireplace.

Refer to wiring diagram on jacket door or in Control Supplement for recommended heat anticipator setting with standard equipment. Wire thermostat as shown.

#### WIRING MULTIPLE ZONES

Refer to zone valve manufacturer's literature for wiring and application. A separate transformer is required to power zone valves. Zoning with circulators requires a relay for each circulator.

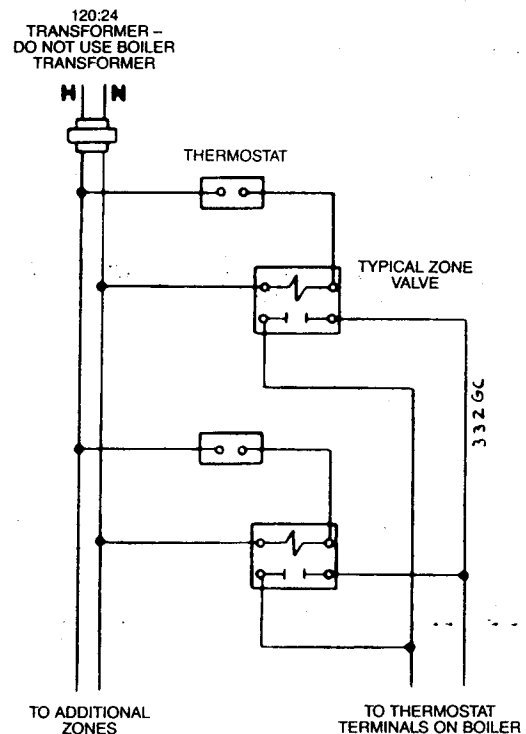

**TYPICAL WIRING - ZONING WITH ZONE VALVES  
FIGURE 10**



## Section VI: Final Adjustments

### WATER TREATMENT

#### DANGER

Do not use petroleum-based cleaning or sealing compounds in boiler system. Severe damage to the boiler will occur.

Continual make-up water will reduce boiler life. Minerals can build up in sections, reducing heat transfer, overheating cast iron, and causing section failure.

For unusually hard water areas or low pH conditions (less than 7.0) consult local water treatment company.

#### Freeze protection (when used):

Use antifreeze especially made for hydronic systems. Inhibited propylene glycol is recommended.

#### WARNING

Do not use automotive, ethylene glycol or undiluted antifreeze. Severe personal injury, death or substantial property damage can result.

50% solution provides protection to about  $-30^{\circ}\text{F}$ .

Local codes may require back-flow preventer or actual disconnect from city water supply.

Determine quantity according to system water content. Boiler water content is listed on back cover. Remember to add in expansion tank water content.

Follow antifreeze manufacturer's instructions.

### FILLING SYSTEM

1. Close manual air vents, drain cock, and automatic air vent, if used.
2. Fill to correct system pressure. Correct pressure will vary with each application. Residential systems are often designed for 12 pounds of cold fill pressure.
3. Open automatic air vent one turn, if used.
4. Open manual water feed valve.
5. a) Starting on lowest floor, open air vents one at a time until water squirts out. Close vent.  
b) Repeat with remaining vents.
6. Close manual water feed valve when correct boiler pressure is reached.

### INSPECT BASE INSULATION

Check to make sure insulation is secure against all four sides of the base.

#### WARNING

If insulation is damaged or displaced, call service technician immediately. DO NOT operate boiler.

#### CAUTION

Ceramic fiber material used in boiler base insulation can cause temporary skin, eye, and upper respiratory irritation.

Use NIOSH or MSHA approved protection when installing or removing this material.

### TO PLACE IN OPERATION

1. Be sure boiler has been correctly filled with water.
2. Follow correct lighting/operating instructions on boiler.

For CG propane gas boilers only:

#### WARNING

Your propane supplier mixes an odorant with the propane to make its presence detectable. In some instances, the odorant can fade, and the gas may no longer have an odor.

Propane gas can accumulate at floor level. Smell near the floor for the gas odorant or any unusual odor. If you suspect a leak, do not attempt to light the pilot.

- Use caution when attempting to light a propane pilot. This should be done by a qualified service technician particularly if pilot outages are common.
  - Periodically check the odorant level of your gas.
  - Inspect boiler and system at least yearly to make sure all gas piping is leak-tight.
  - Consult your propane supplier regarding installation of a gas leak detector. There are some products on the market intended for this purpose. Your supplier may be able to suggest an appropriate device.
3. If boiler starts, go to Step 5.  
If boiler fails to start, go to Step 4.
  4. If boiler fails to start, check for following conditions:
    - a) Loose connection or blown fuse?
    - b) Limit setting below boiler water temperature?
    - c) Thermostat set below room temperature?
    - d) Gas not turned on at meter and boiler?
    - e) Incoming natural gas pressure less than 5" W.C. or propane less than 11" W.C.?
    - f) Access panel not secured in place?
    - g) If above fails to eliminate the trouble, refer to Control Supplement.
  5. Make sure boiler goes through several normal operating cycles.
  6. Turn thermostat or operating control to desired setting.



### Check pilot burner flame:

1. Proper pilot flame
  - a) Blue flame.
  - b) Inner cone engulfing pilot flame sensor.
  - c) Pilot flame sensor glows cherry red.
2. Improper pilot flame
  - a) Overfired – flame is large and lifting or blowing past pilot flame sensor.
  - b) Underfired – flame small; pilot flame sensor not engulfed by inner cone.
  - c) Lack of primary air – flame tip yellow.
  - d) Pilot flame sensor not heated properly.

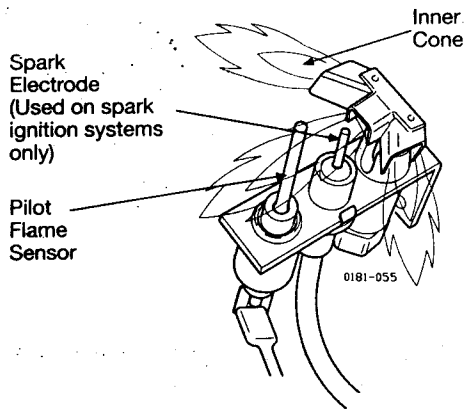

**TYPICAL PILOT BURNER FLAME**  
**FIGURE 11**

### INSPECT VENTING SYSTEM

1. Check venting system at least once a month during heating season. With boiler firing, hold candle or match below lower edge of draft hood "skirt". If flame does not blow out, but burns undisturbed, vent system is functioning properly. If flame blows out or flickers drastically, vent system must be checked for obstructions or other causes of improper venting.
2. Inspect all parts of venting systems for deterioration from corrosion, physical damage, sagging, etc. Correct all conditions found.
3. Verify damper is open when burner ignites. For additional information, see Control Supplement.

### CHECK BURNER FLAMES

1. Proper burner flame, see Figure 12. Yellow-orange streaks may appear – caused by dust.
2. Improper flame:
  - a) Overfired – Flames large.
  - b) Underfired – Flames small.
  - c) Lack of primary air – Yellow tipping on flames; sooting will occur.

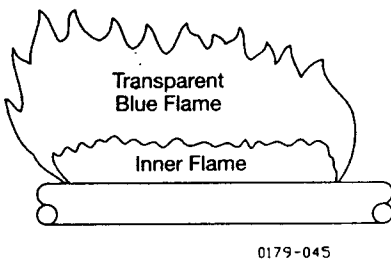

**TYPICAL MAIN BURNER FLAME**  
**FIGURE 12**



## Section VII: Check-out Procedure

Check-off steps as completed.

- 1. Boiler and heat distribution units filled with water?
- 2. Automatic air vent, if used, open one turn?
- 3. Air purged from system?
- 4. Air purged from gas piping? Piping checked for leaks?
- 5. Are proper orifices installed? Check page 5 for proper size.

### DANGER

Proper orifices must be used. Failure to do so will cause severe injury, death or substantial property damage.

- 6. Follow operating/lighting instruction label on boiler for proper start-up. Also refer to "To Place in Operation," page 11.
- 7. Proper burner flame? Refer to "Check Burner Flames," page 12.
- 8. Test limit controls: While burners are operating, move indicator of high limit control below actual boiler water temperature. Burners should go off while circulator continues to operate. Raise limit control above boiler water temperature and burners should reignite.
- 9. Test any additional field-installed controls: If boiler has low water cut-off, additional high limit or other controls, test for operation as outlined by manufacturer. Burners should be operating and should go off when controls are tested. When controls are restored, burners should reignite.
- 10. Button on spill switch pushed in?
- 11. Test ignition system shut-off device:
  - a. For standing pilot – Turn gas cock knob to PILOT position and extinguish pilot flame. Pilot gas flow should stop in less than 3 minutes. Put system back into operation (see page 11).
  - b. For intermittent ignition systems – Connect manometer to outlet side of gas valve. Start boiler, allowing for normal start-up cycle to occur and main burners to ignite. With main burners on, manually shut off gas supply at manual main shut-off gas

valve. Burners should go off. Open manual main shut-off gas valve. Manometer should confirm there is no gas flow. Pilot will relight, flame sensing element will sense pilot flame and main burners reignite.

- 12. High limit control set to design temperature requirements of system? Maximum high limit setting is 240°F.
- 13. For multiple zones, flow adjusted so it is about the same in each zone?
- 14. Thermostat heat anticipator set properly? Refer to "Install Room Thermostat" page 10, and wiring diagram on jacket door.
- 15. Boiler cycled with thermostat? Raise to highest setting. Boiler should go through normal start-up cycle. Lower to lowest setting. Boiler should go off.
- 16. Measure gas input (natural gas only):
  - a. Operate boiler 10 minutes.
  - b. Turn off other appliances.
  - c. At natural gas meter, measure time (in seconds required to use one cubic foot of gas.
  - d. Calculate gas input:
 
$$\frac{3600 \times 1000}{\text{number of seconds from step C}} = \text{Btuh}$$
  - e. Btuh calculated should approximate input rating on rating label.
- 17. Check manifold gas pressure by connecting manometer to downstream test tapping on main gas valve. Manifold gas pressure for natural gas should be 3/4 inches water column and for propane gas should be 1/2 inches water column.
- 18. Several operating cycles observed for proper operation? See Control Supplement for damper check-out procedure.
- 19. Room thermostat set to desired room temperature?
- 20. Installation and Service Certificate on this page completed?
- 21. All instructions shipped with this boiler reviewed with owner or maintenance person, returned to envelope and given to owner or displayed near boiler?

## Installation and Service Certificate

BOILER MODEL \_\_\_\_\_ SERIES \_\_\_\_\_ CP NUMBER \_\_\_\_\_ DATE INSTALLED \_\_\_\_\_

BTU INPUT \_\_\_\_\_

- Installation instructions have been followed.
- Check-out sequence has been performed.
- Above information is certified to be correct.
- Information received and left with owner/maintenance person.

Installer \_\_\_\_\_ (Company) \_\_\_\_\_ (Address) \_\_\_\_\_ (Phone) \_\_\_\_\_ (Installer's Signature)



## Section VIII: Maintenance

### Also Refer to Additional Instructions Shipped With The Boiler For Specific Control Operation and Troubleshooting

#### NOTICE

Boiler should be inspected, cleaned and, if necessary, adjusted once a year. A qualified service agency should be called.

#### WARNING

To avoid personal injury, death or property damage, keep boiler area clear and free from combustible materials, gasoline and other flammable vapors and liquids.

#### WARNING

##### TO AVOID PERSONAL INJURY, BEFORE SERVICING:

1. Disconnect electrical supply.
2. Shut-off gas supply.
3. Allow boiler to cool.

Do not block flow of air to boiler. Incomplete combustion and carbon monoxide emissions can cause severe personal injury, death or substantial property damage.

Do not store sources of hydrocarbons (i.e., bleaches, cleaners, chemicals, sprays, paint removers, fabric softeners, etc.) in boiler area. This can contribute to shortened boiler/vent system life.

### Suggested Minimum Maintenance Schedule for Qualified Service Technician Only

#### Beginning of each heating season:

1. Annual service call by a qualified service agency.
2. Check burners and flueways and clean if necessary. Reference "Clean Boiler Heating Surfaces" and "Cleaning Main Burners," page 15.
3. Visually inspect base insulation. Reference "Inspect Base Insulation," page 11.
4. Follow procedure "To Place in Operation," page 11.
5. Visually inspect pilot and burner flames. Reference "Check Burner Flames," pages 11 and 12.
6. Visually inspect venting system for blockage, deterioration or leakage. Reference "Inspect Venting System," page 12.
7. Check operation of low-water cut-off, if used, and additional field-installed controls. Refer to manufacturer's instructions.
8. Check that boiler area is free from combustible materials, gasoline and other flammable vapors and liquids.
9. Check for and remove any obstruction to flow of combustion or ventilation air.
10. Follow instructions on circulator to oil, if oil lubricated. Overoiling will damage the circulator. Water lubricated circulators do not need oiling.

#### Periodically during heating season:

1. Check relief valve. Reference manufacturer's instructions on relief valve tag.
2. Test low water cut-off, if used. Blowdown if low water cut-off is float type. Reference manufacturer's instructions.

#### Monthly during heating season:

1. Check for leaks in boiler and piping. If found, repair at once.

#### WARNING

Leaks must be repaired at once. Failure to do so can damage boiler, resulting in substantial property damage.

#### DANGER

Do not use petroleum based cleaning or sealing compounds in boiler system. Severe damage to boiler will result, causing substantial property damage.

2. Visually inspect pilot and burner flames. Reference "Check Burner Flames," pages 11 and 12.
3. Visually inspect venting system for blockage, deterioration or leakage. Reference "Inspect Venting System," page 12.
4. Check automatic air vent for leakage. If leaking, remove vent cap and push valve core in to wash off sediment that may have accumulated on valve seat. Release valve, replace cap and open one turn.

#### End of each heating season:

1. Follow "Annual Shutdown Procedure," page 15.



#### Clean boiler heating surfaces:

### WARNING

This product contains fiberglass wool and ceramic fiber materials. Airborne fibers from these materials have been listed by the State of California as a possible cause of cancer through inhalation. Apply special care when handling ceramic fiber (base insulation) materials. Ceramic fibers can be converted to chrysothalites, a substance listed as a probable cause of cancer through inhalation. Suppliers of fiberglass wool products recommend the following precautions to be taken when handling these materials:

#### Precautionary Measures

- Avoid breathing fiberglass dust and contact with skin or eyes.
- Use NIOSH approved dust/mist respirator.
- Wear long-sleeved, loose fitting clothing, gloves and eye protection.
- Wash work clothes separately from other clothing. Rinse washer thoroughly.
- Operations such as sawing, blowing, tear out, and spraying may generate airborne fiber concentration requiring additional protection.

#### First Aid Measures

- Eye contact – Flush eyes with water to remove dust. If symptoms persist, seek medical attention.
- Skin contact – Wash affected areas gently with soap and warm water after handling.

1. Follow shut-down procedure.
2. Remove breeching, damper (when used) and draft hood. Remove upper rear jacket panel. Turn back jacket insulation to expose collector hood.
3. Remove collection hood. Clean excess boiler cement from collector hood and cast iron sections.
4. Remove radiation plates that hang between sections.

5. Remove burners from base of boiler. Follow "Cleaning Main Burners," page 15.
6. Place newspaper in base of boiler to collect soot that will fall.
7. With a wire flue brush, clean between sections.
8. Remove newspaper and soot. Vacuum or brush base and surrounding area.
9. Replace radiation plates.
10. Replace collector hood. Seal with boiler cement.
11. Replace insulation and jacket panel.
12. Replace main burners.

### DANGER

CG burner tubes must be seated in slots in burner rest with openings face up; CGX burners must be fastened securely to manifold assembly with openings face up. Main burner orifices must inject down center of burner. Failure to properly seat burners will result in severe personal injury, death or substantial property damage.

13. Replace draft hood, damper (when used) and breeching
14. Follow "To Place in Operation" procedure.

NOTE: Excessive sooting indicates improper gas combustion. If found, call a qualified service agency or your local gas utility to check for proper combustion and make any necessary adjustments.

#### Cleaning main burners:

1. Vacuum or brush burners to remove dust and lint.

### DANGER

When replacing, CG burner tubes must be seated in slots in burner rest with openings face up; CGX burners must be fastened securely to manifold assembly with openings face up. Main burner orifices must inject down center of burner. Failure to properly seat burners will result in severe personal injury, death or substantial property damage.

#### Annual shut-down procedure:

1. Follow "To Turn Off Gas to Appliance" instructions on boiler.
2. DO NOT drain system unless exposure to freezing temperatures will occur. If antifreeze is used in system, do not drain.



## Section IX: Replacement Parts

### Parts Lists

#### Component-Assemblies Replacement

(Refer to Control Supplement for control replacement)

Section Assembly .....	17
Base Assembly (CG Series 11) .....	18
Base Assembly (CGX Series 1) .....	19
Jacket Assembly .....	20
Boiler Trim Assembly .....	21

#### COMPONENT REPLACEMENT INSTRUCTIONS

Before replacing any parts on the boiler:

1. Turn off power
2. Shut off gas supply

Refer to the appropriate diagram for parts replacement.

Replacement parts must be purchased through a local Weil-McLain distributor. When ordering, specify boiler model and series and include description and number of replacement part. Results from using modified or other manufactured parts will not be covered by warranty and may damage boiler or impair operation.

Weil-McLain Sales Ref. No. are found in Weil-McLain Boilers and Controls Repair Parts Book.

Some parts are stock items (■) and can be purchased from a local supply house.





## Section Assembly CG Series 11 CGX Series 1

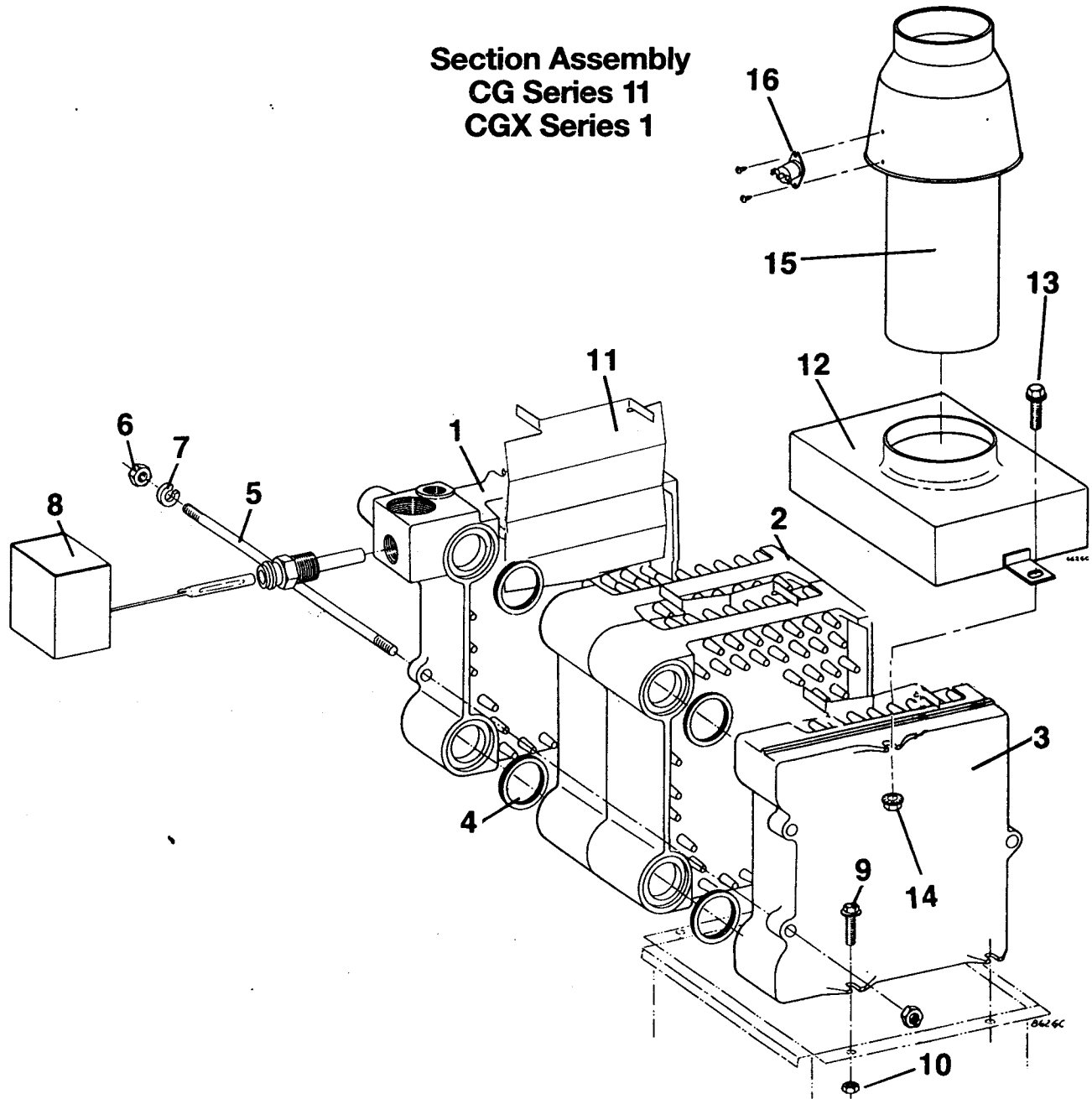

FIG. NO.	DESCRIPTION	VENDOR/PART NUMBER	W-M SALES REF. NO.
1	Left End Section	W-M	10B008
2	Intermediate Section	W-M	10B009
3	Right End Section	W-M	10B010
4	Square Cut Seal, 2"	W-M	11B165
5	Tie Rod - CG-25/CGX/CG-3 1/8x9 CGX/CG-4 1/8x12 CGX/CG-5 1/8x15 CGX/CG-6 1/8x18 CG-7 1/8x21 CG-8 1/8x24	W-M W-M W-M W-M W-M W-M	10B921 10B922 10B923 10B924 10B925 10B926
6	Nut, 1/4-14 Reg. Hex		■
7	Washer, 1/4 Reg. Helical Spring Lock		■
8	Limit Control w/1/2" well	W-R 11B81-3	10C055
9	Screw, 1/4-18x1 Whiz-Lock		■
10	Nut, 1/4-18 2-way Lock		■
11	Radiation Plate	W-M	10C472
12	Flue Collector Hood - CG-25 CGX/CG-3 CGX/CG-4 CGX/CG-5 CGX/CG-6 CG-7 CG-8	W-M W-M W-M W-M W-M W-M W-M	11B307 10B607 10B608 10B609 10B610 10B611 10B612

FIG. NO.	DESCRIPTION	VENDOR/PART NUMBER	W-M SALES REF.
13	Screw, 1/4-20x1 1/4 Whiz-Lock Nut, 1/4-20 Whiz-Lock		■ ■
15	Draft Hood - CG-25 CGX/CG-3 CGX/CG-4 CGX/CG-5 CGX/CG-6 CG-7 CG-8	W-M W-M W-M W-M W-M W-M W-M	11B24 11B24 11B24 11B24 11B24 11B24 11B25
16	Spill Switch	W-M	10C437

■ LISTED PART OR EQUIVALENT CAN BE PURCHASED AT LOCAL SUPPLY HOUSE.



## Base Assembly CG Series 11

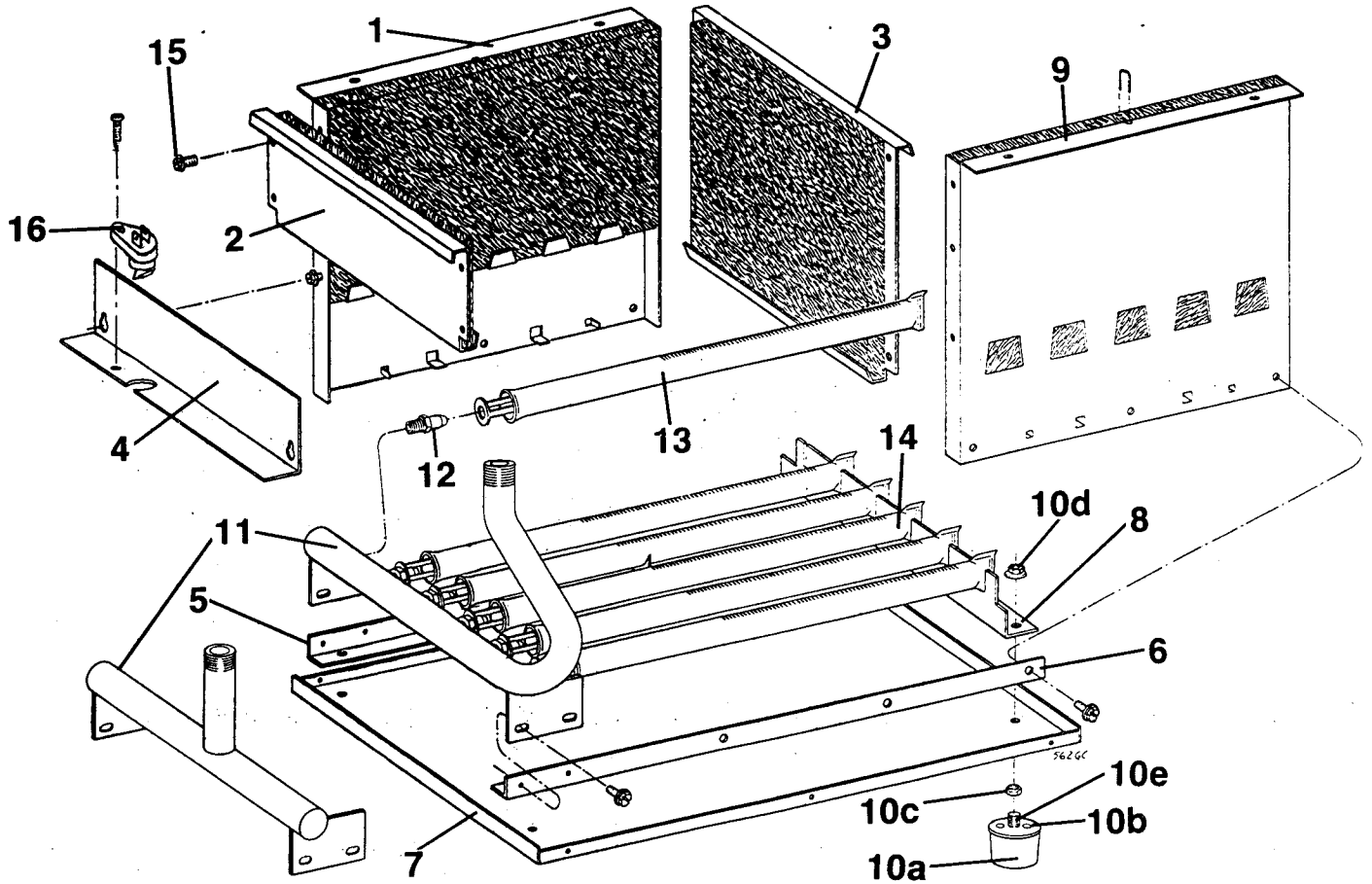

FIG. NO.	DESCRIPTION	VENDOR/PART NUMBER	W-M SALES REF. NO.
1	Base Side Panel	W-M	10B803
2	Base Front Cross Tie - CG-25/CG-3	W-M	10B811
	CG-4	W-M	10B812
	CG-5	W-M	10B813
	CG-6	W-M	10B814
	CG-7	W-M	10B815
	CG-8	W-M	10B816
3	Base Back Cross Tie - CG-25/CG-3	W-M	10B796
	CG-4	W-M	10B797
	CG-5	W-M	10B798
	CG-6	W-M	10B799
	CG-7	W-M	10B800
	CG-8	W-M	10B801
4	Base Access Panel - CG-25/CG-3	W-M	10B804
	CG-4	W-M	10B805
	CG-5	W-M	10B806
	CG-6	W-M	10B807
	CG-7	W-M	10B808
	CG-8	W-M	10B809
5	Base Pan Angle - L.H.	W-M	11B251
6	Base Pan Angle - R.H.	W-M	11B252
7	Base Pan - CG-25/CG-3	W-M	11B253
	CG-4	W-M	11B254
	CG-5	W-M	11B255
	CG-6	W-M	11B256
	CG-7	W-M	11B257
	CG-8	W-M	11B258
8	Burner Rest - CG-25	W-M	11B259
	CG-3	W-M	11B260
	CG-4	W-M	11B261
	CG-5	W-M	11B262
	CG-6	W-M	11B263
	CG-7	W-M	11B264
	CG-8	W-M	11B265

FIG. NO.	DESCRIPTION	VENDOR/PART NUMBER	W-M SALES REF. NO.
9	Base Insulation Set - CG-25/CG-3	W-M	11B092
	CG-4	W-M	11B093
	CG-5	W-M	11B094
	CG-6	W-M	11B095
	CG-7	W-M	11B096
	CG-8	W-M	11B097
	Staple, 1 3/4" for base insulation	■	
10	Leg, Screw-on Assembly*	W-M	10B982
10a	Leg	-	-
10b	Washer, 3/8" Hole	-	-
10c	Nut, 5/16-18 Jam	-	-
10d	Nut, 5/16-18 Whiz-Lock	-	-
10e	Screw, 5/16-18 x 2 1/4 Mach. Fl. Hd. Phil.	-	-
11	Manifold - CG-25	W-M	11B296
	CG-3	W-M	11B298
	CG-4	W-M	11B300
	CG-5	W-M	11B302
	CG-6	W-M	11B304
	CG-7	W-M	11B305
	CG-8	W-M	11B306
12	Orifice, Main Burner - Natural, #46 Drill	W-M	10B936
	Propane, 1.3 mm	W-M	10B937
13	Burner, Steel	W-M	10B870
14	Burner, Steel w/Pilot Bracket, Standing Pilot Nat. Gas	W-M	10C473
	Burner, Steel w/Pilot Bracket, Standing Pilot LP Gas, PI	W-M	10B871
15	Screw, 10-32 x 3/8 STP Type D Hex Wash. Hd. Slot ZP	■	
16	Rollout Thermal Fuse Element	W-M	10C257

■ LISTED PART OR EQUIVALENT CAN BE PURCHASED AT LOCAL SUPPLY HOUSE.  
\* SOLD AS ASSEMBLY ONLY



## Base Assembly CGX Series 1

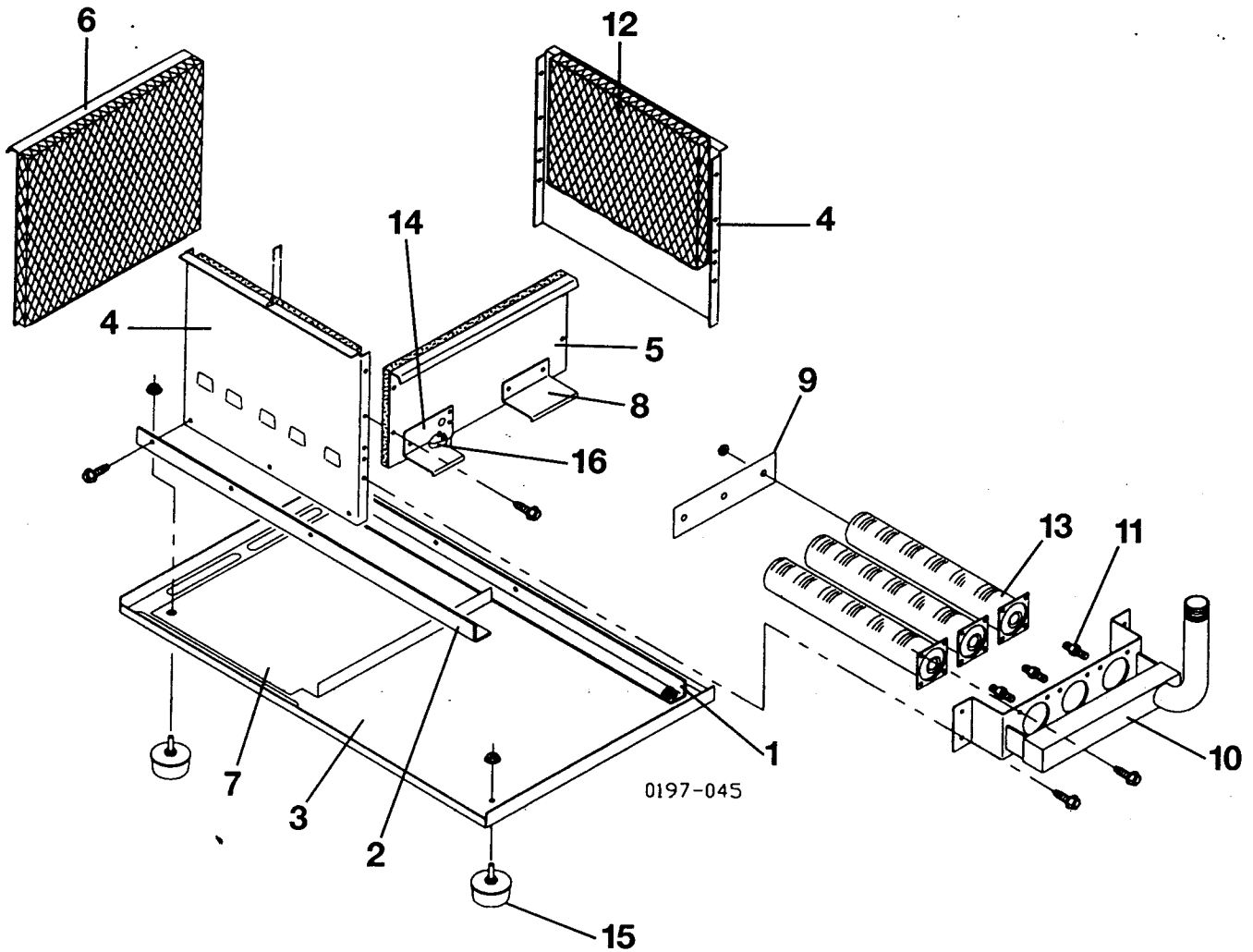

FIG. NO.	DESCRIPTION	BOILER SERIES NO.	SALES REF. NUMBER
1	Base Pan Angle RH	1	10B681
2	Base Pan Angle LH	1	10B682
3	Base Pan - CGX-3 CGX-4 CGX-5 CGX-6	1 1 1 1	11B415 11B416 11B417 11B418
4	Base Side Panel	1	11B139
5	Base Front Cross Tie - CGX-3 CGX-4 CGX-5 CGX-6	1 1 1 1	11B419 11B420 11B421 11B422
6	Base Back Cross Tie - CGX-3 CGX-4 CGX-5 CGX-6	1 1 1 1	11B423 11B424 11B425 11B426
7	Base Pan Air Baffle - CGX-3 CGX-4 CGX-5 CGX-6	1 1 1 1	11B427 11B428 11B429 11B430
8	Base Cross Tie Baffle - CGX-3, 4, 5 CGX-5, 6	1 1	11B431 11B432

FIG. NO.	DESCRIPTION	BOILER SERIES NO.	SALES REF. NUMBER
9	Base Rear Spacer Strip For Burners - CGX-3 CGX-4 CGX-5 CGX-6	1 1 1 1	11B433 11B434 11B435 11B436
10	Manifold Assembly CGX-3 CGX-4 CGX-5 CGX-6	1 1 1 1	11B437 11B438 11B439 11B440
11	Main Burner Orifice (35 Drill)	1	11B446
12	Base Insulation Set - CGX-3 CGX-4 CGX-5 CGX-6	1 1 1 1	11B441 11B442 11B443 11B444
13	Burner Assembly	1	11B447
14	Pilot Bracket CGX	1	10B953
15	Boiler Leg Kit	1	11B153
16	Rollout Thermal Fuse Element	1	10C257



## Jacket Assembly CG Series 11 CGX Series 1

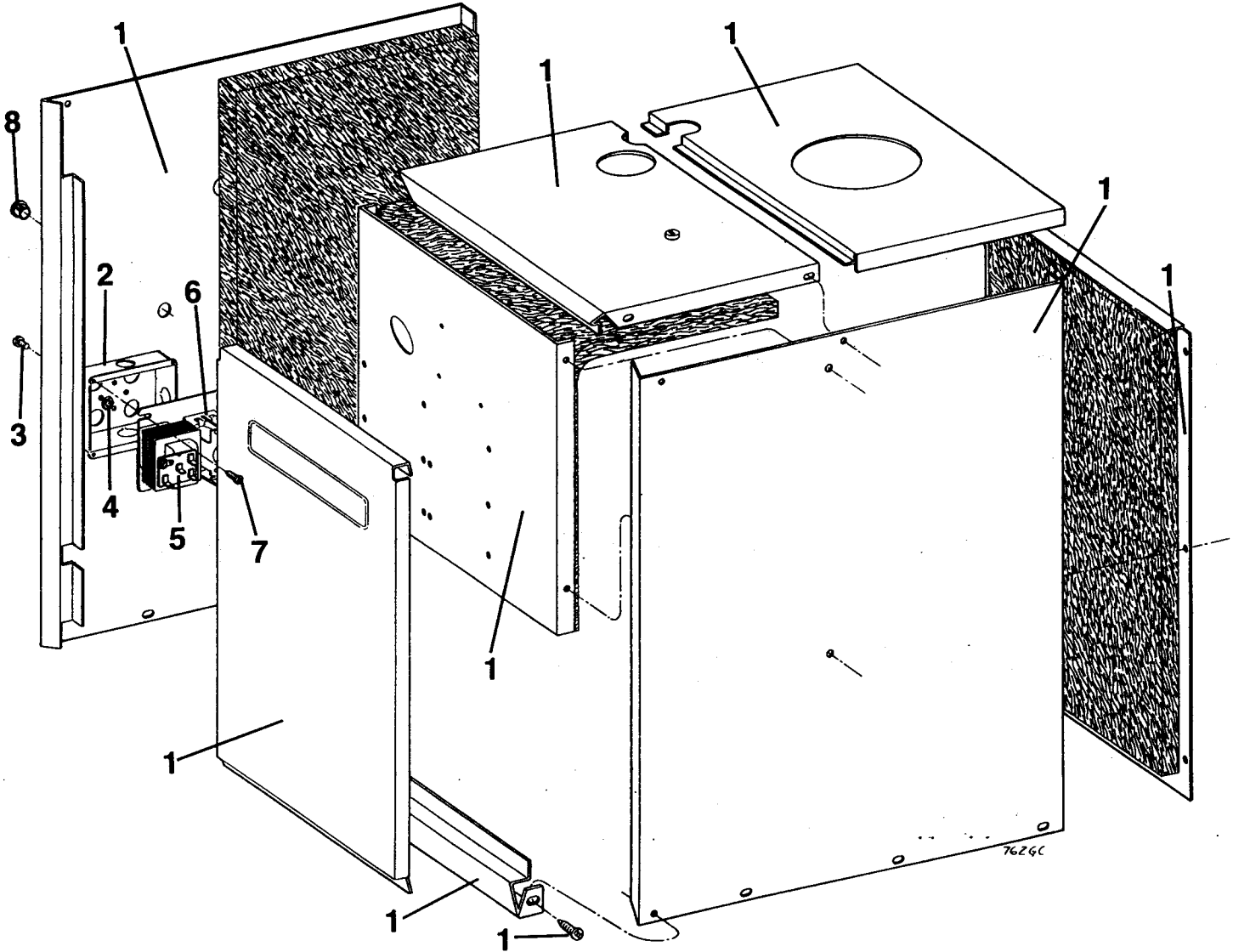

FIG. NO.	DESCRIPTION	VENDOR/PART NUMBER	W-M SALES REF. NO.
1	CGX/CG Repair Jacket Carton (includes top panel, removable top panel, left side panel, right side panel, door, rear panel, interior panel, front bottom cross tie, labels, screws)		
	CG-25	W-M	10J150
	CGX/CG-3	W-M	10J151
	CGX/CG-4	W-M	10J152
	CGX/CG-5	W-M	10J153
	CGX/CG-6	W-M	10J154
	CG-7	W-M	10J155
	CG-8	W-M	10J156

FIG. NO.	DESCRIPTION	VENDOR/PART NUMBER	W-M SALES REF. NO.
2	Junction Box, 4 x 4 x 1 1/2		■
3	Screw, 10-32 x 1/2 Mach. Pan Hd. Phil.		■
4	Nut, 10-32 Hex Green-plated		■
5	Transformer w/Plug-in Recp. and Bale Wire		■
6	Relay		■
7	Screw, #8 x 1/2 Sht. Mtl. Pan Hd. Phil.		■
8	Bushing, Thermostat Wire		■

■ LISTED PART OR EQUIVALENT CAN BE PURCHASED AT LOCAL SUPPLY HOUSE.

## Boiler Trim Assembly CG Series 11 CGX Series 1

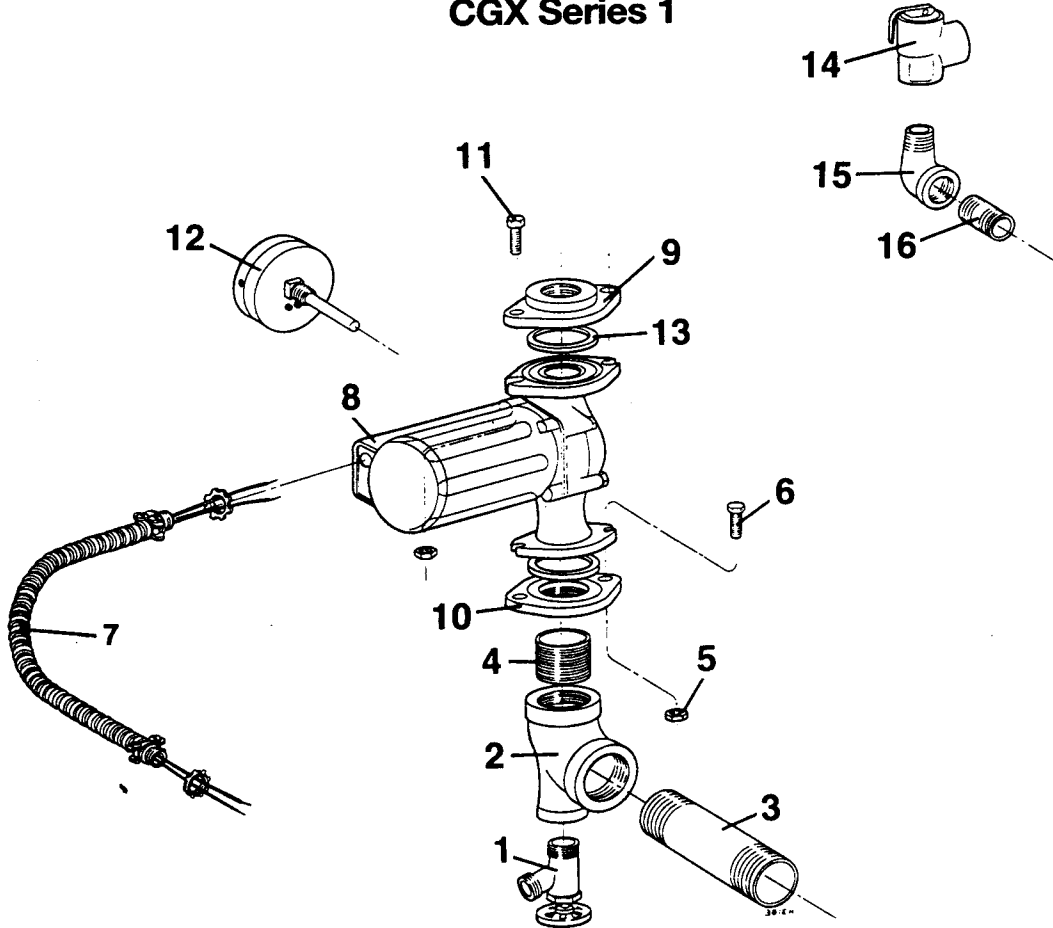

FIG. NO.	DESCRIPTION	VENDOR/ PART NUMBER	W-M SALES REF. NO.
1	Drain Valve, 3/4"		10C159
2	Tee Black CG-25 3/4x3/4x3/4		■
3	Tee, Reducer Black CGX-3-6/CG-3-8 1 1/4x3/4x1 1/4		■
	Nipple, Black - CG-25 3/4x5 w/3/4x1 1/4 Black Bushing	Taco 007 1 1/4x5 1/2	■
	CGX-3-6/CG-3-8	B&G LR20 1 1/4x6	■
		B&G100/Taco 110	■
		1 1/4x5	■
4	Nipple, Close CG-25-3/4 CGX-3-6/CG-3-8-1 1/4		■
5	Nut, Hex 1/4-14		■
6,11	Screw, Cap Hex Hd. 3/16-14x1 1/2 - SMALL PUMPS		■
	Screw, Cap Hex Hd. 3/16-14x1 1/2 - LARGE PUMPS		■
7	Wiring Harness, Box to Pump		■
8	Circulator, SMALL	Taco 007 or B&G LR20	10C195
	Circulator, LARGE	Taco 110 or B&G 100	10C194 10C197 10C196
9	Pump Flange - CG-25 - 3/4 NPT CGX-3-5/CG-3-5 - 1 NPT CGX-6/CG-6-7 - 1 1/4 NPT CG-8 - 1 1/2 NPT	B&G or Taco B&G or Taco B&G or Taco B&G or Taco	■ ■ ■ ■

FIG. NO.	DESCRIPTION	VENDOR/ PART NUMBER	W-M SALES REF. NO.
10	Pump Flange - CG-25 - 3/4 NPT CGX-3-6/CG-3-8 - 1 1/4 NPT	B&G or Taco B&G or Taco	■ ■
12	Pressure-Temperature Gauge	Ametek Spec #135392 Short Shank	10C034
13	Gasket	Taco - SMALL & LARGE PUMPS B&G LR 20 B&G 100	■ ■ ■
14	Relief Valve, 30# Male or Female		■
15	Street Ell, 3/4 Black for Female / Ell, 3/4 Black for Male		■
16	Nipple, 3/4x2 Black		■
***	Silicone Sealant - 400°F	Dow 732 RTV	■
***	Boiler Cement		■

■ LISTED PART OR EQUIVALENT CAN BE PURCHASED AT LOCAL SUPPLY HOUSE.  
\*\*\* NOT SHOWN



**DIMENSIONS**

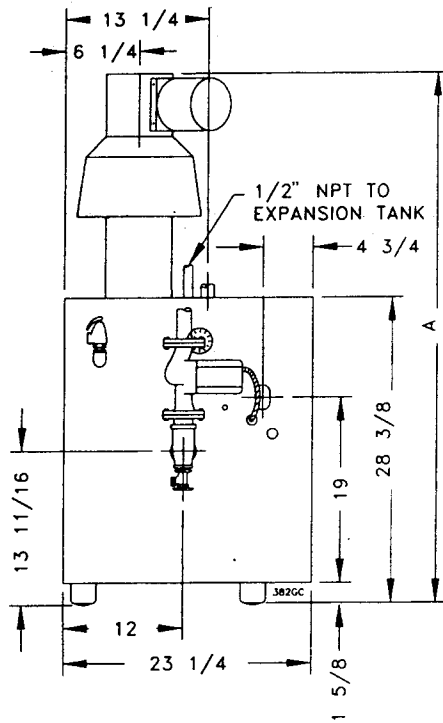
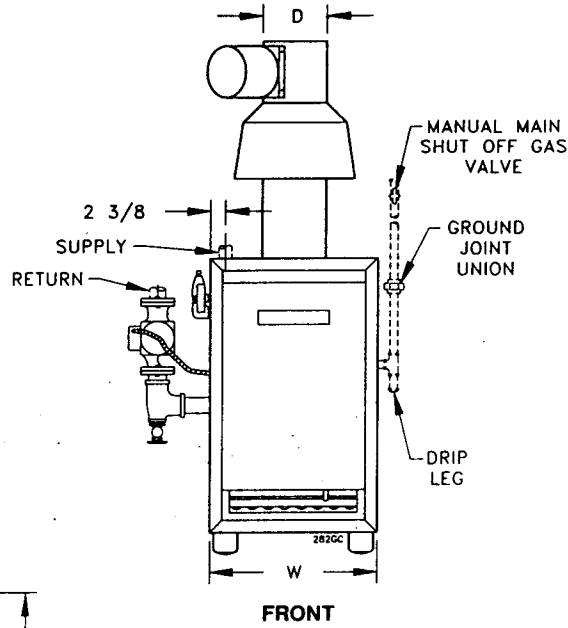

**LEFT SIDE**

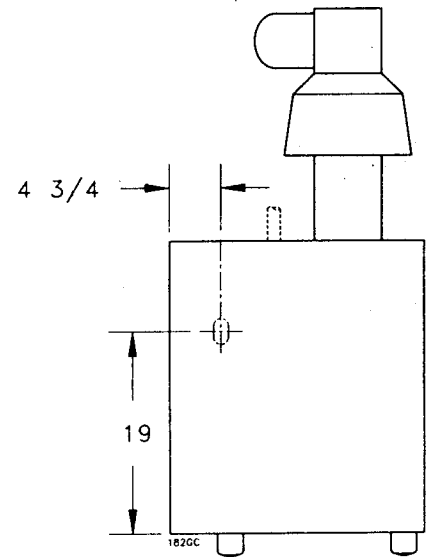

**RIGHT SIDE**

Boiler Number	Supply Outlet		Return Inlet		Gas Connection Pipe Size		Gas Manifold Pipe Size All Gases	Dimensions		
	No.	Pipe Size	No.	Pipe Size	Natural Gas	Propane Gas		A	D	W
CG-25	1	1 1/4"	1	3/4"	1/2"	1/2"	1/2"	45 3/8"	4"	10"
CGX/CG-3	1	1 1/4"	1	1"	1/2"	1/2"	1/2"	52 3/8"	4"	10"
CGX/CG-4	1	1 1/4"	1	1"	1/2"	1/2"	1/2"	54 3/8"	5"	13"
CGX/CG-5	1	1 1/4"	1	1"	1/2"	1/2"	1/2"	57 7/8"	6"	16"
CGX/CG-6	1	1 1/4"	1	1 1/4"	1/2"	1/2"	1/2"	60 7/8"	6"	19"
CG-7	1	1 1/4"	1	1 1/4"	3/4"	3/4"	3/4"	62 1/8"	7"	22"
CG-8	1	1 1/4"	1	1 1/2"	3/4"	3/4"	3/4"	64 7/8"	7"	25"

**RATINGS**



DOE



Boiler Number ▲	A.G.A. (United States)		C.G.A. (Canada)				I=B=R Ratings BTU/Hr. *	Boiler Water Content in Gallons	D.O.E. Seasonal Efficiency (A.F.U.E.)			Chimney and Breeching Size
	Input BTU/Hr.	D.O.E. Heating Capacity ‡	0 - 2000 Ft.		2000 - 4500 Ft.				SPDN	SPDL	PIDN	
			Input BTU/Hr.	Output BTU/Hr.	Input BTU/Hr.	Output BTU/Hr.						
CG-25	52,000	43,000	52,000	41,600	46,800	37,400	37,000	1.5	80.2	80.4	83.0	4" I.D. x 20'
CG-3	70,000	58,000	70,000	56,400	63,000	50,400	50,000	1.5	80.1	80.7	82.2	4" I.D. x 20'
CGX-3 •	70,000	59,000	70,000	56,400	63,000	50,400	51,000	1.5	-	-	83.3	4" I.D. x 20'
CG-4	105,000	88,000	105,000	84,000	94,500	75,600	77,000	2.1	80.4	81.4	82.9	5" I.D. x 20'
CGX-4 •	105,000	88,000	105,000	84,000	94,500	75,600	77,000	2.1	-	-	83.3	5" I.D. x 20'
CG-5	140,000	117,000	140,000	112,800	126,000	100,800	102,000	2.7	80.4	81.5	82.5	6" I.D. x 20'
CGX-5 •	140,000	117,000	140,000	112,800	126,000	100,800	102,000	2.7	-	-	83.3	6" I.D. x 20'
CG-6	175,000	145,000	175,000	140,000	157,000	126,000	126,000	3.3	80.5	81.6	82.2	6" I.D. x 20'
CGX-6 •	175,000	146,000	175,000	140,000	157,000	126,000	127,000	3.3	-	-	83.3	6" I.D. x 20'
CG-7	210,000	174,000	210,000	168,000	189,000	151,200	151,000	3.8	80.5	81.7	81.8	7" I.D. x 20'
CG-8	245,000	202,000	245,000	196,000	220,000	176,400	176,000	4.4	80.5	81.8	81.4	7" I.D. x 20'

- ▲ Add "SPD" to designator for boiler with standing pilot; add "PID" to designator for boiler with intermittent electronic ignition system. (Canada only - add "SP" to designator for boiler with standing pilot; add "PI" to boiler with intermittent electronic ignition system; add prefix "A" for high altitude.) "N" designates natural gas, "L" designates propane. Available for natural and propane gas with standing pilot, natural gas for PID (no propane for PID). N available for millivolt systems.
- ‡ Based upon standard test procedures prescribed by the United States Department of Energy.
- \* Net I=B=R Ratings are based on net installed radiation of sufficient quantity for the requirements of the building and nothing need be added for normal piping and pick-up. Ratings are computed on an allowance for factor of 1.15. For unusual piping and pick-up loads, consult your Weil-McLain area sales office.
- Available only as "PID" (or "PI" - Canada only) for natural gas firing only. Add prefix "A" for high altitude.

**STANDARD EQUIPMENT**

**STANDARD EQUIPMENT**

- Insulated Extended Jacket
- Draft Hood (in separate carton)
- Automatic Vent Damper
- Aluminized Steel Burners
- Non-Linting Pilot Burner
- Combination Gas Valve
- Built-in Air Eliminator
- Combination Relay Receptacle and 40VA Transformer
- High Limit Temperature Control
- Circulator (Taco 007 or B&G LR20)
- 30 PSI Relief Valve
- Boiler Drain Valve
- Combination Pressure - Temperature Gauge
- Highest Efficiency Models - PID System
- High Efficiency Models - SPD System
- Spill Switch
- Rollout Thermal Fuse Element
- Electrical Junction Box
- Plug-in Circulator Relay

**ADDITIONAL EQUIPMENT**

Fill-Trol System (diaphragm-type expansion tank, fill and check valve, automatic air vent and fittings) - #109 Sizes 3 thru #110 Size 6 - shipped in separate carton.