

PROJECT	QUANTITY	ITEM NO
---------	----------	---------

Rotisserie display cabinets

MODEL **SCD-6**
SCD-8



General Information

Henny Penny rotisserie displays are designed to hold and display cooked chickens until carving, serving, or selling. Display units correspond dimensionally to rotisseries, which can be stacked on the displays to save space and provide convenient access.

- SCR-6 rotisserie stacks on SCD-6
- SCR-8 rotisseries stack on SCD-8

Standard Features

- Durable stainless steel cabinet.
- Tempered clear glass doors with black matrix shaded borders.
- Magnetic door closures with optional customer side handle.
- Units hold full rotisserie loads.
- Incandescent lighting for warm, even illumination.
- Gentle even forced air heating.
- Fully insulated top and sidewalls.
- Removable drip tray for easy cleaning.
- Adjustable, removable wire shelves.
- Stacking kit shipped with unit.

SCR-8 rotisserie stacked on model SCD-8 rotisserie display.

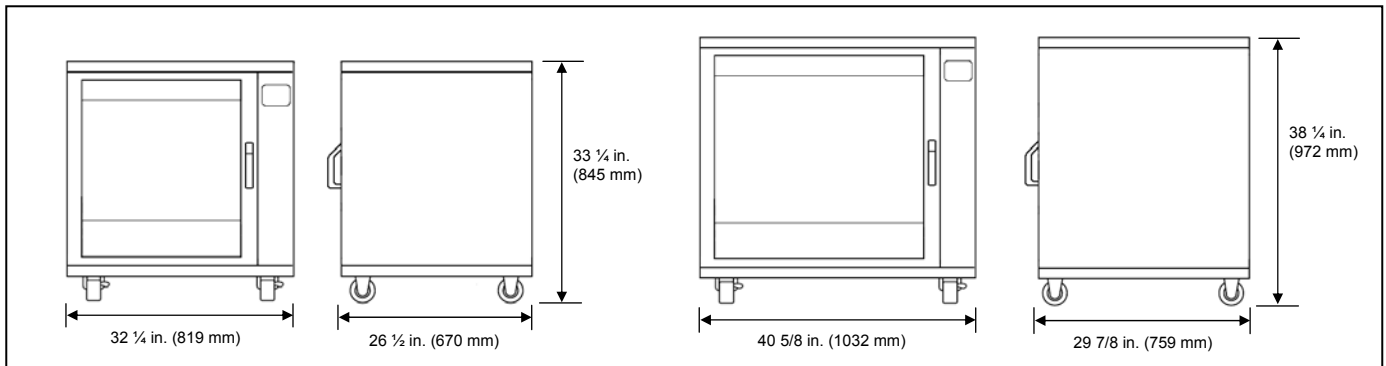

Dimensions

	SCD-6	SCD-8
Height:	33 1/4 in. (845 mm)	38 1/4 in. (972 mm)
Width:	32 1/4 in. (819 mm)	40 5/8 in. (1032 mm)
Depth:	26 1/2 in. (670 mm)	29 7/8 in. (759 mm)

Crated dimensions

Length:	40 in. (1016 mm)	48 in. (1219 mm)
Depth:	33 1/4 in. (857 mm)	37 in. (940 mm)
Height:	42 in. (1067 mm)	48 in. (1219 mm)
Volume:	32.8 cu. ft. (0.93 m ³)	49.3 cu. ft. (1.40 m ³)

Net weight

	N/A
Crated weight:	SCD-6 315 lbs. (143 kg) SCD-8 403 lbs. (183 kg)

Lighting: (4) 40W bulbs

Capacity: 2 1/2 lbs. (1.1 kg) whole birds

SCD-6	SCD-8
24 whole birds: 6 per rack, 4 racks on 6 in. (152 mm) centers	35 whole birds, 7 per rack, 5 racks on 6 in. (152 mm) centers
Up to 7 racks on 3 in. (76 mm) centers	Up to 9 racks on 3 in. (75 mm) centers

Electrical

Volts	Phase	Cycle/Hz	Watts	Amps
208	1	50/60	2300	11.0
240	1	50/60	2300	9.6

Laboratory certifications



Bidding Specifications

- Provide Henny Penny rotisserie display merchandising unit, SCD-6 or SCD-8.
- Units shall be made of stainless steel and structural steel framework.
- Units shall be pass-through design. Customer shall specify handle or no handle on customer side door.
- Casters or leveling legs available, standard. Includes (4) wire racks.

Continuing product improvement may subject specifications to change without notice.

<input type="checkbox"/> APPROVED	<input type="checkbox"/> APPROVED AS NOTED	<input type="checkbox"/> RESUBMIT
AUTHORIZED SIGNATURE		DATE



Henny Penny Corporation
PO Box 60 Eaton OH 45320 USA

+1 937 456.8400 800 417.8417
+1 937 456.8434 Fax 800 417.8434 Fax

www.hennypenny.com