

INSTRUCTIONS

HRO SERIES ROTISSERIE OVENS &

HRW SERIES ROTISSERIE OVENS WITH WARMERS

MODELS

<i>HRO101</i>	<i>ML-43775</i>
<i>HRO303</i>	<i>ML-43776</i>
<i>HRO505</i>	<i>ML-43778</i>
<i>HRW101</i>	<i>ML-43777</i>
<i>HRW303</i>	<i>ML-43779</i>



EXECUTIVE OFFICES
701 RIDGE AVENUE
TROY, OHIO 45374-0001

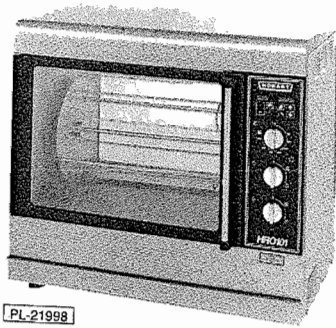

PL-21998

Model HRO101 Oven

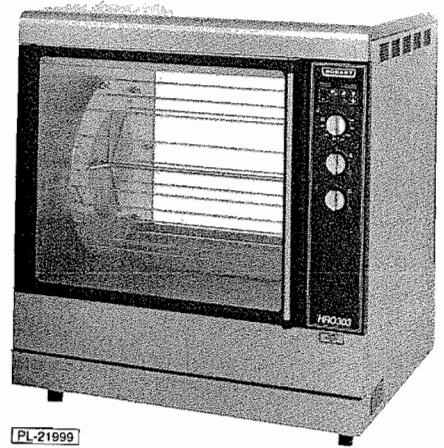

PL-21999

Model HRO303 Oven



PL-22001

Model HRW101 Oven/Warmer



PL-22000

Model HRO505 Double Oven

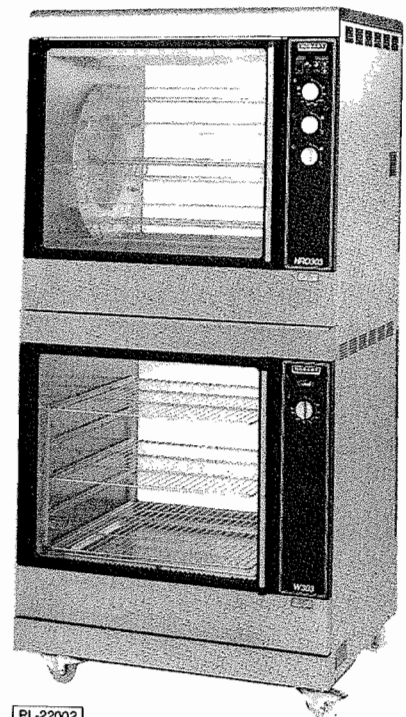

PL-22002

Model HRW303 Oven/Warmer

Installation, Operation and Care of HRO & HRW SERIES ROTISSERIE OVENS

SAVE THESE INSTRUCTIONS

GENERAL

The HRO and HRW Series Rotisserie Ovens and Warmers feature stainless steel interior and exterior for ease of cleaning. Rotating, self-basting spits or flat baking racks and combination convection and radiant heat provide thorough cooking and even browning yet eliminate hot spots. The grease drawer has a drain plug for elimination of excess fat and can be completely removed for cleaning. Oven controls provide "Manual" or "Automatic" (timer controlled) operation where the END TIME or PROCESS TIME can be preset. Tempered glass doors, both front and back, and quartz lighting promote visual appeal and stimulate customer interest. Doors can be rehinged — contact your local Hobart service office.

HRW Series have a single compartment upper oven and a lower warming cabinet. The warming cabinet features low velocity, high humidity air circulation which keeps foods moist. The warming cabinet has three shelves.

Ovens come in two sizes, with or without warming cabinet below.

HRO101 — oven with four spits (16 chickens).

HRO303 — large oven with seven spits (35 chickens).

HRW101 — HRO101 oven with W101 warming cabinet below.

HRW303 — HRO303 oven with W303 warming cabinet below.

HRO505 — two HRO303 ovens, stacked.

Features and Options

	Quantity Required per Oven*					
	Spit	Basket	Turkey Spit	Baking Plate	Chicken Rack	Warmer Shelves
HRO101	4 std.	4 opt.	1 opt.	4 opt.	NA	NA
HRO303	7 std.	7 opt.	1 opt.	NA	7 opt.	NA
HRO505	14 std.	14 opt.	2 opt.	NA	14 opt.	NA
HRW101	4 std.	4 opt.	1 opt.	4 opt.	NA	3 std.
HRW303	7 std.	7 opt.	1 opt.	NA	7 opt.	3 std.

* Rotisserie inserts can be intermixed requiring less than the maximum shown in the chart.

INSTALLATION

Immediately after unpacking the oven, check for possible shipping damage. If the oven is found to be damaged after unpacking, save the packaging material and contact the carrier within 15 days of delivery.

Prior to installation, test the electrical service to assure that it agrees with the specifications on the machine data plate located on the right side panel near the controls.

HRO505 and HRW303 are secured to the skid with four screws which must be removed.

LOCATION

WARNING: THE OVEN SHOULD NOT BE ACCESSIBLE TO THE CUSTOMER. HOT GLASS AND PARTS CAN CAUSE BURNS.

The oven may be placed where cooking may be observed to enhance customer awareness. The oven must be installed on a level surface. A minimum clearance of 10" from the rear, 10" from any glass, and 4" from each side panel must be maintained. The installation location must allow adequate clearances for servicing and for proper operation of the front and rear doors.

LEGS / CASTERS

Counter models, HRO101 and HRO303, are furnished with 1½" legs. HRO505, HRW101 and HRW303 are furnished with 2 swivel and 2 locking swivel casters.

ASSEMBLY

Place the two bottom plates in the oven. The two plates slant to the middle to allow fat to drip into the grease drawer (Figs.1, 2).

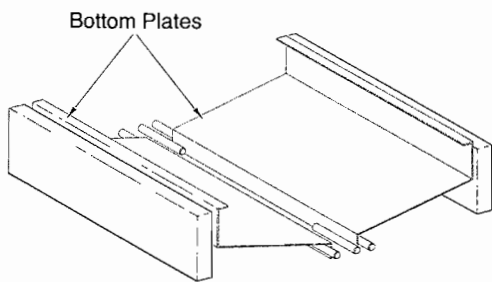

Model HRO101

PL-50803

Fig. 1

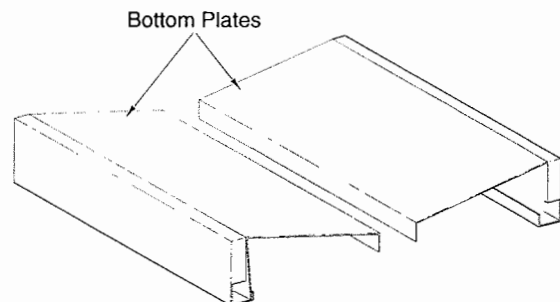

Model HRO303

PL-50804

Fig. 2

ELECTRICAL CONNECTIONS

WARNING: ELECTRICAL AND GROUNDING CONNECTIONS MUST COMPLY WITH THE APPLICABLE PORTIONS OF THE NATIONAL ELECTRICAL CODE AND/OR OTHER LOCAL ELECTRICAL CODES.

WARNING: DISCONNECT ELECTRICAL POWER SUPPLY AND PLACE A TAG AT THE DISCONNECT SWITCH INDICATING THAT YOU ARE WORKING ON THE CIRCUIT.

Access the electrical connection point by removing the right side panel. Comply with the appropriate wiring diagram attached to the oven. Electrical supply cord and plug should be supplied by installer. Replace right side panel.

ELECTRICAL DATA

MODEL	VOLTS	HERTZ	PHASE	CIRCUIT SIZE* (AMPS)
HRO101	208	60	1	35
	208	60	3	20
	240	60	1	35
	240	60	3	20
HRO303	208	60	1	60
	208	60	3	35
	240	60	1	60
	240	60	3	35
HRO505	208	60	3	70
	240	60	3	70
HRW101	208	60	1	50
	208	60	3	30
	240	60	1	50
	240	60	3	30
HRW303	208	60	3	50
	240	60	3	45

* Maximum Circuit Breaker Size / Minimum Circuit Amperage compiled in accordance with the National Electrical Code, 1990 edition.

BEFORE FIRST USE

WARNING: UNPLUG BEFORE CLEANING.

Before using the oven for the first time, it must be "burned in" to release any odors that might result from heating the new surfaces in the oven.

Clean the oven, accessories and warmer (if present), both inside and outside, with warm soapy water. Rinse thoroughly and wipe dry with a soft clean cloth. Avoid water contact with the quartz lamps.

Operate the oven at the maximum temperature setting of 450°F for four hours. Smoke with an unpleasant odor will normally be given off during this burn-in period.

OPERATION

WARNING: HOT GLASS, GREASE, AND PARTS CAN CAUSE BURNS. USE CARE WHEN OPERATING AND SERVICING THE OVEN.

OVEN CONTROLS (Fig. 3)

Automatic Controls

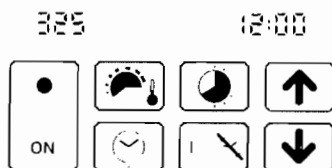

Dial Thermostat

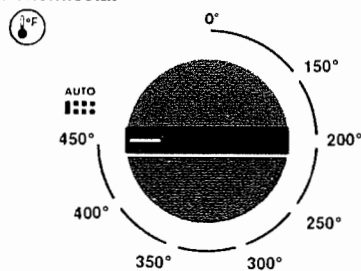

Rotisserie

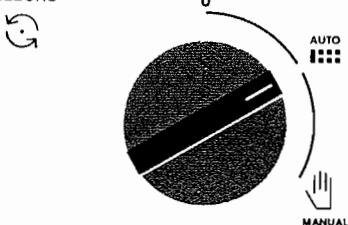

Main Power

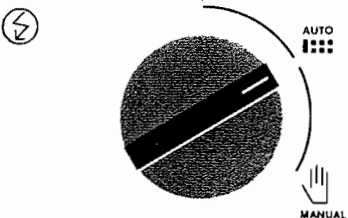

PL-21996

Fig. 3

Automatic Controls — SEE PAGES 7 AND 8.

Display — SHOWS TEMPERATURE (°F) AND TIME (HH:MM).

Automatic: Colon flashing, cooking time remaining is shown.

Manual: Colon not flashing, time of day displays (12 hour clock).

Dial Thermostat — 0 MEANS HEAT IS OFF.

Automatic: Turn dial to maximum temperature [AUTO setting]. Set Automatic Controls, pages 7 and 8.

Manual: Turn dial to desired temperature (150 – 450°F).

Rotisserie — 0 MEANS ROTISSERIE IS OFF.

Automatic: Set three dials on AUTO and press ON; see Automatic Controls, pages 7 and 8.

Manual: Set the Rotisserie and Main Power dials on the hand symbol. Use Dial Thermostat.

Main Power — 0 MEANS OFF.

Automatic: Set the three dials on AUTO and press ON; see Automatic Controls, pages 7 and 8.

Manual: Set the Rotisserie and Main Power dials on the hand symbol. Use Dial Thermostat.

Loading Product

Turn the Rotisserie dial to the hand symbol to rotate. Turn it to AUTO to stop and load. Repeat until all loading is complete. Make sure the product is distributed evenly. Close the door.

The Dial Thermostat must be set at the maximum (450°F) for Automatic Operation.

If no temperature or roasting time has been programmed, the Automatic Control recalls the values for the previous Automatic Cooking Operation. These values can be displayed by pressing the appropriate symbol.

AUTOMATIC CONTROLS (Fig. 4)

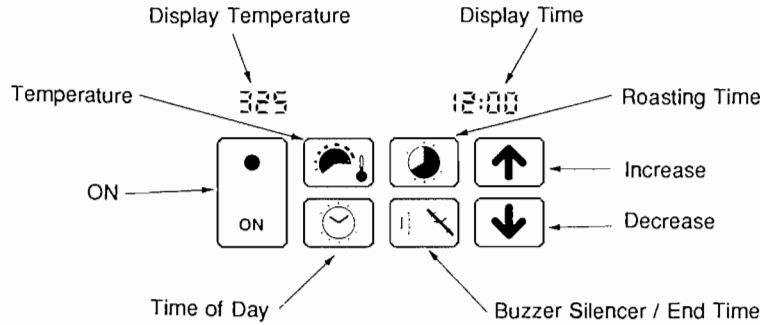

Fig. 4

PL-21997

Automatic Controls can regulate the roasting temperature, stop cooking at a preset time, or allow the buzzer to be timed. The last entered Temperature and Roasting Time is always retained in memory by the Automatic Controls. Set the Temperature and Roasting Time, then press ON to begin.

• Setting the Temperature

	DISPLAY TEMP	
Press	325	— Displays the thermostat setting (150 - 450°F).
Press +	326	— Increases the temperature setting.
Press +	324	— Decreases the temperature setting.

• Setting the Roasting Time

	DISPLAY TIME	
Press	1:15	— Displays the automatic roasting time.
Press +	1:16	— Increases the automatic roasting time.
Press +	1:14	— Decreases the automatic roasting time.

• Press ON to begin.

Setting an Early Warning Buzzer

Assume the roasting time is one hour and fifteen minutes and it is currently 2 o'clock. The cycle completes and the buzzer will sound at 3:15. If you want an early warning buzzer for basting or whatever reason, program as follows:

	DISPLAY TIME	
Press	3:15	— Displays the sum of the current time plus the roasting time.
Press +	3:00	— Buzzer will sound at 3:00.
Press ON.		— Roasting begins.

- At 3:00, the interim buzzer sounds. Press to silence.
- At 3:15, roasting stops and buzzer sounds again. Press to silence.

Setting the End Time (Delayed Start)

Assume the roasting time is one hour and fifteen minutes and it is currently 2 o'clock. If you want to finish roasting at 4:00, program the Automatic Control as follows:

	DISPLAY TIME	
Press	3:15	— Displays the sum of the current time plus the roasting time.
Press +	4:00	— Roasting will stop at 4:00.
Press ON.		— The red light on the ON button is lit. Rotisserie says off until:

- Roasting begins at 2:45. Colon starts flashing.
- Roasting stops at 4:00; buzzer sounds. Press to silence.

Interrupting an Automatic Cooking Operation

If you want to temporarily interrupt an Automatic Cooking Operation, press ON.

- The On lamp flashes. Colon stops flashing.
- The Rotisserie stops.
- Heat lamps and elements go off.
- The Automatic Control retains the set temperature and the remaining roasting time.
- The current temperature and remaining roasting time are displayed.
- Because heating is off, the temperature decreases. The control does not compensate.
- To restart, press ON again. The Automatic Cooking Operation will resume.

Stopping an Automatic Cooking Operation

When an Automatic Cooking Operation is completed, a buzzer sounds.

If you want to temporarily interrupt an Automatic Cooking Operation, see above.

If you want to abort an Automatic Cooking Operation, turn Main Power OFF. The Temperature and Roasting Time will be retained in memory, not the remaining cooking time.

Changing a Setting





All settings can be changed before, during or after the cooking process except for the time of day which cannot be changed during an Automatic Cooking Operation. After a change, the operation continues according to the new values.

Stopping the Rotisserie

Turn Rotisserie OFF. One lamp continues to burn. Heat is Off. Rotisserie stops.

Setting the Time of Day

The Time of Day cannot be reset during an Automatic Cooking Operation. The ON light on the ON button must be off. Colon is not flashing. Set the Time of Day as follows:

		DISPLAY TIME	
		9:23	— The current time of day is displayed.
Press	 + 	9:24	— Increases the time of day.
Press	 + 	9:22	— Decreases the time of day.

Turning the Buzzer OFF

Press .

Resetting the Automatic Control

Turn Main Power OFF and ON. The Automatic Control retains Time and Temperature for the last Automatic Cooking Operation. Remaining cooking time and early warning buzzer are lost.

Operating in Fahrenheit or Celsius Degrees

To operate the oven with Fahrenheit degrees, press  while turning the Main Power dial from 0 to AUTO. The Fahrenheit lamp will be lit. The oven will continue to operate in Fahrenheit degrees.

To operate in Celsius, press  while turning the Main Power dial from 0 to AUTO. The oven will continue to operate in Celsius degrees.

PREPARING THE PRODUCT

The oven is not designed to roast frozen foods. Use only fresh or previously thawed product. Before and after preparing poultry, clean all work areas. Maintain proper sanitation at all times.

SPITS

WARNING: SKEWERS ARE SHARP. BE VERY CAREFUL WHEN LOADING PRODUCT.

Skewer spits into whole poultry so that the 2 points go through the chest and thighs (Fig.5). **Leave approximately 1/2" between each chicken to permit proper browning.** Place the sharp end of the spit into the holes on one side of the rotisserie positioning the breast toward the operator. Fit the groove on the opposite end of the spit into the corresponding holes on the other side of the rotisserie. Turkey spit (optional) requires removal of the rotisserie drum to roast one whole turkey.

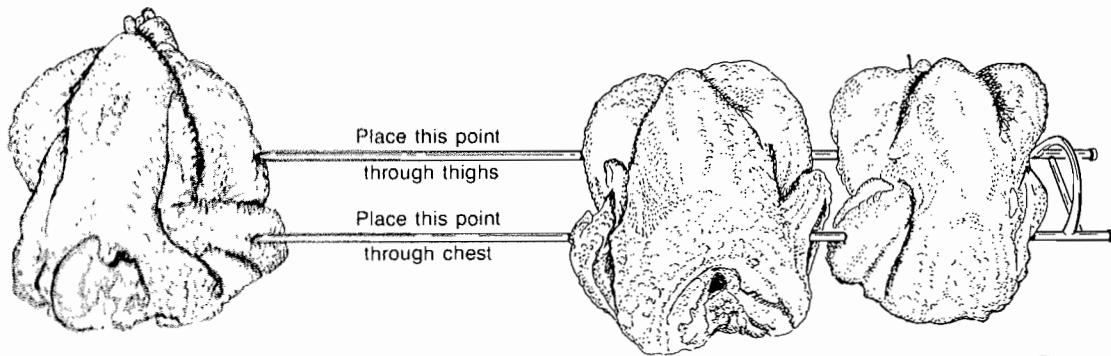

Fig. 5

Tying Legs (Fig. 6)

Tie the legs of chicken or cornish hen together if desired.

Baskets

Make sure product in baskets does not stick out of the basket. Shortening is not needed.

Loading the Oven

Make sure the loaded spits will clear the top of the oven. Place weight so the rotisserie is evenly balanced. If spits and baskets are intermixed, use one less on each side of the spit so product does not collide during rotation. Insert spits, leave one space, then hang baskets (Fig. 7). Be sure spits and baskets do not touch when rotating. On HRO303 ovens, baskets hang on pins on opposite sides of the rotisserie. On HRO101, a pin on each side of the basket fits into the ringed holes on the rotisserie.

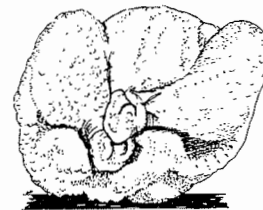

Fig. 6

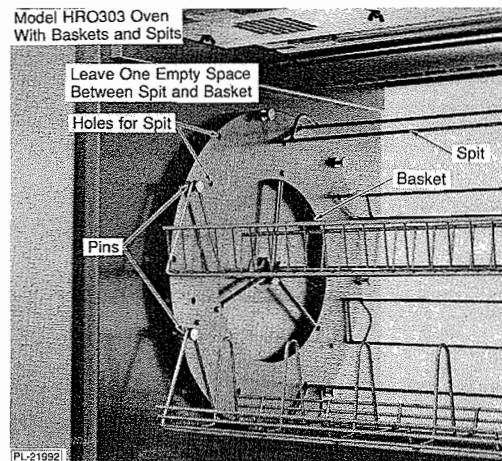

Fig. 7

SUGGESTED ROASTING GUIDELINES

The chart indicates suggested cooking times and temperatures. Initial product temperature, size, shape, and other factors may require adjustment to suit your operation.

Product	Thermostat (°F)	Time* (HH:MM)	Internal Temperature (°F)	Capacity		
				HRO101	HRO303	HRO505
Chicken, Whole, 2 lb	350 - 375	1:30 - 2:00	180 - 185	12 - 16	28 - 35	56 - 70
Cornish Hens, 1 lb	350 - 375	1:00 - 1:30	180 - 185	16 - 20	28 - 42	56 - 84
Duck, Whole, 4 - 4½ lb	350 - 375	2:00 - 2:30	180 - 185	8	14	28
Turkey, Whole, 11 - 13 lb	350 - 375	2:00 - 2:30	180 - 185	1	1	1
Roast Beef, 4 lb	350 - 375	1:00 - 1:30	140 Rare 160 Medium 180 Well Done	8	14	28
Pork Ribs, 3 lb	350	1:00 - 1:30	170	4	7	14

* Times listed are for HRO101.

Unloading the Oven

Opening the door does not stop the rotisserie or cooking process. Turn rotisserie Off.

Remove spits or baskets. Advance rotation by turning rotisserie to Manual. Remove the next utensil.

Emptying the Grease Drawer (Fig. 8)

Empty the grease drawer when necessary. Be careful if grease is warm. Open the drawer. Provide a suitably large bucket or vessel under the drain plug and unscrew the plug. When empty, screw the drain plug tight.

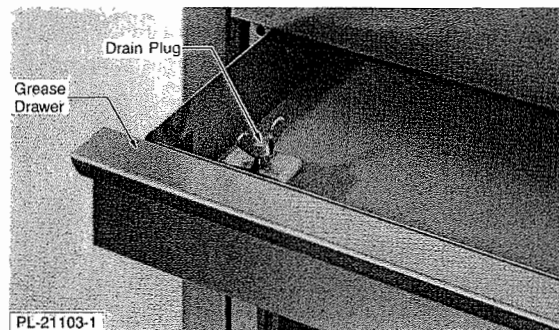

Fig. 8

Cleaning the Grease Drawer

When the machine is idle, empty and then remove the drawer. Wash it in a sink with warm soapy water. Any hard soil can be scrubbed with a soft, non-scratching pad.

WARMER CONTROLS (Fig. 9)

Thermometer



Dial Thermostat

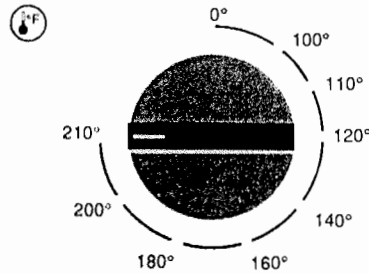

PL-22003

Fig. 9

Thermometer — Displays temperature in degrees Fahrenheit.

Thermostat — 0 is OFF. Turn dial to desired temperature.

USING THE WARMERS (Models W101 and W303)

Fill the warmer drawer with cold water about three-quarters full to minimize steaming. Use softened water, if available, to reduce lime build-up in the drawer.

Cooked product other than poultry may be held in the warmer for 3 to 4 hours; then it must be refrigerated.

When holding poultry, it is recommended that the temperature of the warmer be at least 180 – 200°F and that poultry be held no longer than 2 hours.

Every 4 to 5 hours, add lukewarm water to the drawer as needed. If water evaporates completely, product will dry out.

CLEANING

WARNING: DISCONNECT ELECTRICAL POWER BEFORE CLEANING.

Allow oven to cool before cleaning.

CAUTION: Do not use oven cleaners. Do not clean with a high pressure hose.

Wash with warm soapy water, rinse and dry or use a commercial glass cleaner.

Clean the control panel with a damp cloth only.

Remove the oven rotisserie, spits, bottom plates, grease drawer, and other removable parts and wash in a sink with warm soapy water. Rinse thoroughly and dry with a soft clean cloth.

Return the clean drawer to the bottom of the oven. Clean the oven interior with warm soapy water. Rinse thoroughly and dry with a soft clean cloth. Remove any spillage in the grease drawer and wipe dry with a clean cloth.

On W101 and W303, remove the water drawer and shelves; wash with warm soapy water, rinse and dry. If scale builds up on the water drawer or warmer interior, soak with vinegar. Rinse thoroughly and dry with a soft clean cloth.

CLEANING QUARTZ LAMPS

CAUTION: Do not clean the quartz lamps in the top of the oven with soap and water.

Clean lamps with a cloth soaked in alcohol. Do not touch the lamps with your bare hands. Be very careful when cleaning or handling the lamps. Lamps can be broken by mishandling.

Monthly, clean the ventilation grate and the fan blades in the top of the oven. Use warm soapy water, rinse thoroughly, and dry with a soft clean cloth. To reach the fan blades, remove the ventilation grate by unscrewing the nuts on either side of the vents. Then unscrew the nut in the center of the fan blade by turning **clockwise**. After cleaning, reinstall in reverse order.

MAINTENANCE

WARNING: UNPLUG ELECTRICAL POWER SUPPLY BEFORE PERFORMING ANY MAINTENANCE.

WARNING: HOT GLASS, GREASE, AND PARTS CAN CAUSE BURNS. USE CARE WHEN OPERATING AND SERVICING THE OVEN.

Model HRO101

Should the rotisserie become out of alignment, use the allen key (provided) to unscrew and retighten the drum on the rotor shaft until properly aligned.

SERVICE

Contact your local Hobart office.