

GE Monogram[®]

Installation

Instructions

27" Built-In Ovens

Models

ZEK757WW

ZEK757BW

ZEK737WW

ZEK737BW

Before you begin—Read these instructions completely and carefully.

IMPORTANT: Save these instructions for local inspector's use.

IMPORTANT: OBSERVE ALL GOVERNING CODES AND ORDINANCES.

NOTE TO INSTALLER: Be sure to leave these instructions with the Consumer.

NOTE TO CONSUMER: Keep these instructions with your Use and Care Book for future reference.

⚠ WARNING This appliance must be properly grounded. See “Electrical Supply”, page 16.

If you have questions concerning the installation of this product, call the GE Answer Center® Consumer Information Service at 800.626.2000, 24 hours a day, 7 days a week.

Proper installation is the responsibility of the installer. Product failure due to improper installation is not covered under the GE Appliance Warranty. See the Use & Care Guide for warranty information.

If you received a damaged oven, you should contact your dealer.

CAUTION:

- This oven should be installed by a qualified installer or service technician.
- Never use the oven for warming or heating a room. Prolonged use of the oven without adequate ventilation can be hazardous.

Check with local utilities for electrical codes which apply in your area. Local codes vary. Installation, electrical connections and grounding must comply with applicable codes. In the absence of local codes, the oven should be installed in accordance with National Electrical Code ANSI/NFPA 70-1990.

Contents

<i>Design Information</i>	
Models Available	3
Dimensions and Clearances	3
Cabinet Style Options	4
Installation Options	5
Side-by-side Installation Option	5
<i>Cabinetry</i>	
Tools and Materials required	6
Framed Cabinet, Double Oven	6
Framed Cabinet, Single Oven	7
Recessed Installation: Front framed cabinets with inset doors and drawers	8
Frameless Cabinets	9
Single Oven Installed Below a Microwave Oven	10
Single Oven Installed Below a Countertop	11
<i>Cabinetry Modification Suggestions</i>	
Provide Oven Supports	12
Install Oven Supports	12
Determine Need for Filler Panels	13
Filler Panel Construction	13
Cut Rail for Filler Panel	14
Cut Appearance Panel	14
Determine Location of Cleats	14
Cut and Secure Cleats to Filler Panel	15
Secure Rail to Appearance Panel	15
Secure Assembled Filler Panel to Cabinet	15
<i>Installation</i>	
Tools and Materials Required	16
Electrical Locations	16
Finalize Installation	17
Route Cable Through Cutout	17
Secure Oven to Cabinet	18
Replace the Oven Door	18
Connect Electrical	18

Design Information

Built-In Ovens

Models available

ZEK757WW
White double convection oven

ZEK757BW
Black double convection oven

ZEK737WW
White single convection oven

ZEK737BW
Black single convection oven

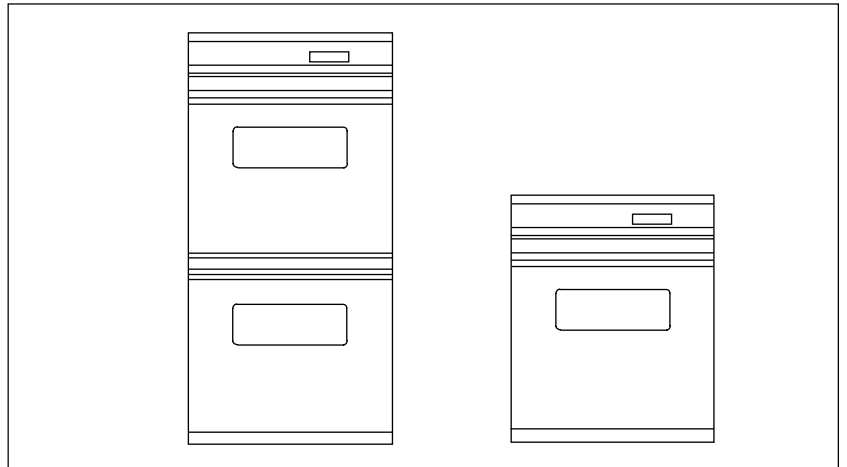

With both single and double built-in styles, contemporary Monogram ovens offer an array of choices for the custom kitchen:

- Built-in double convection ovens
- Built-in single convection ovens
- Monogram built-in ovens are available in sophisticated black or glistening white.

Dimensions and clearances

Double oven

- A - 20" (508 mm)
- B - 23-1/2" (597 mm)
- C - 26-13/16" (681 mm)
- D - 50-3/4" (1289 mm)
- E - 26-3/16" (665 mm)
- F - 1-3/4" (44 mm)
- G - 15/16" (24 mm)
- H - 49-5/8" (1260 mm)
- J - 1/4" (6 mm)
- K - 7/8" (22 mm)

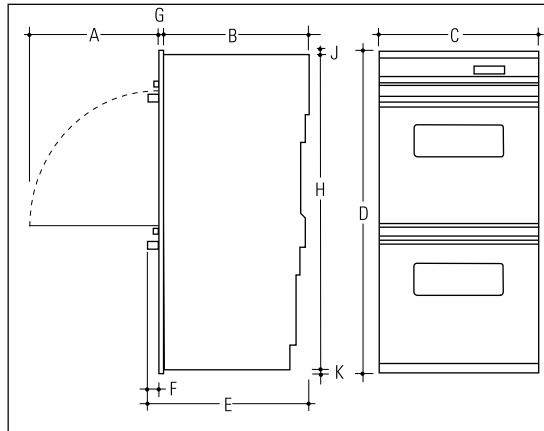

Single oven

- A - 20" (508 mm)
- B - 23-1/2" (597 mm)
- C - 26-13/16" (681 mm)
- D - 28-9/16" (725 mm)
- E - 26-3/16" (665 mm)
- F - 1-3/4" (44 mm)
- G - 15/16" (24 mm)
- H - 27-7/16" (697 mm)
- J - 1/4" (6 mm)
- K - 7/8" (22 mm)

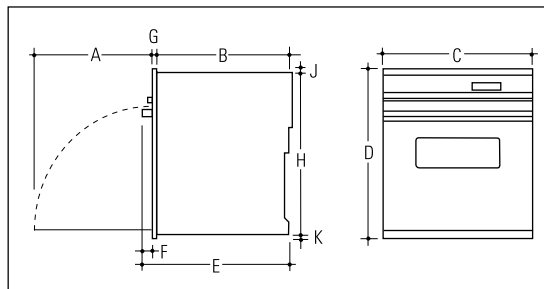

Design Information

Built-In Ovens

Cabinet style options

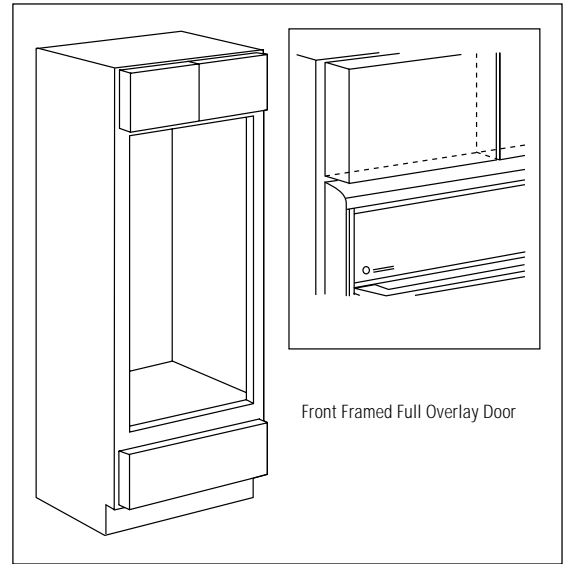
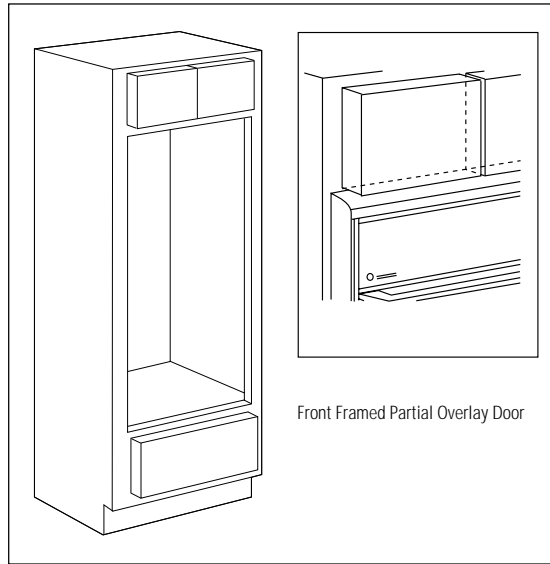

Monogram ovens are installed directly into a wall or wall oven cabinetry, 27" minimum width. The front surface of the ovens will be nearly flush with surrounding cabinetry. To obtain optimal appearance, cabinet cutouts must be exact. The examples shown here illustrate typical styles of 27" cabinets and oven fit. Installation instructions for each of these basic cabinetry styles are provided in this section.

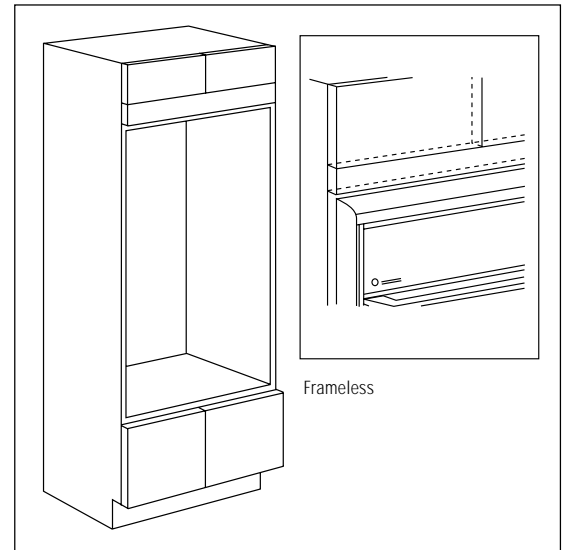

Designer Note: Whenever possible, align the oven with cabinetry details such as drawers, doors and reveals.

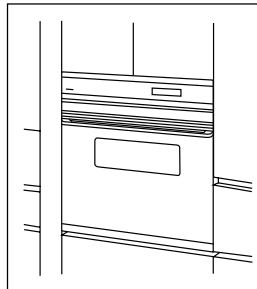

Monogram ovens can be recessed into front framed cabinets with inset flush doors. This installation requires 26-7/8" wide and 24-1/2" deep cutout. See page 6 for details.

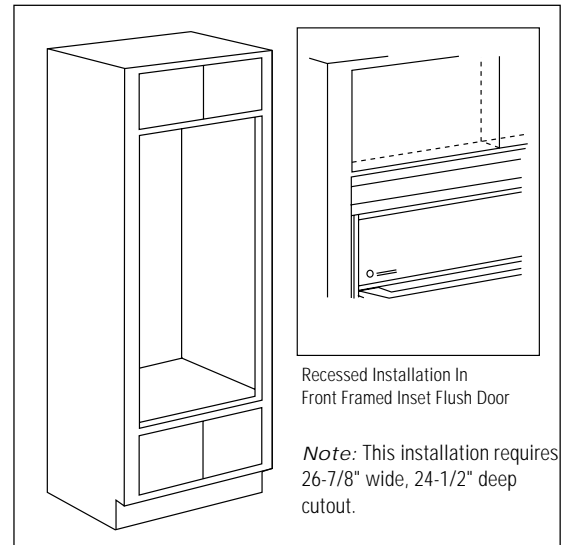

Design Information

Built-In Ovens

Installation options

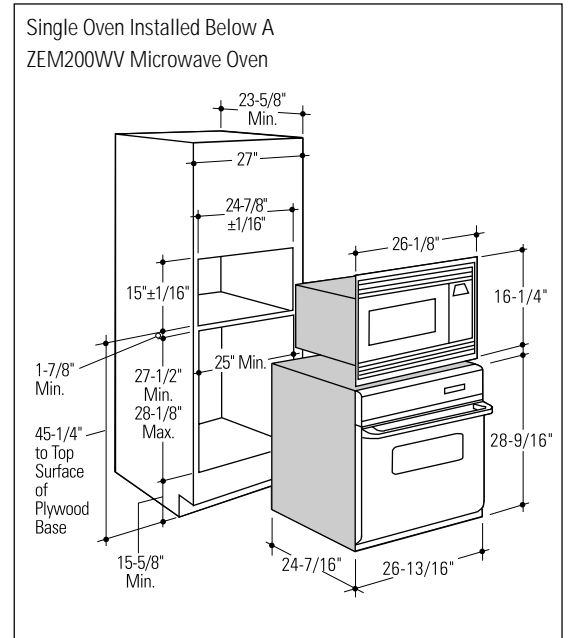
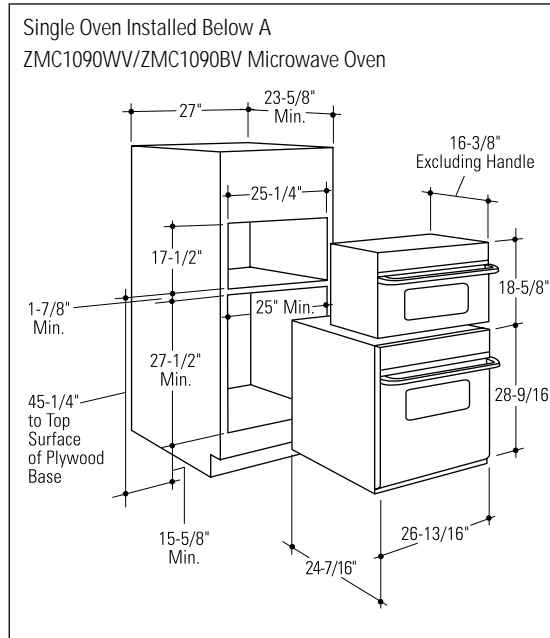

- Install a single oven alone or below any Monogram microwave oven.
- For an integrated look, install a single oven below the ZMC1090BV and ZMC1090WV built-in style microwave ovens. No trim kits required.
- Install a single oven below a ZEM200WV microwave oven. JX827WN trim kit required.

Side-by-side installation option

Install single ovens side-by-side. Minimum spacing allowed:

- 5" minimum separation between cabinet openings—any type oven.

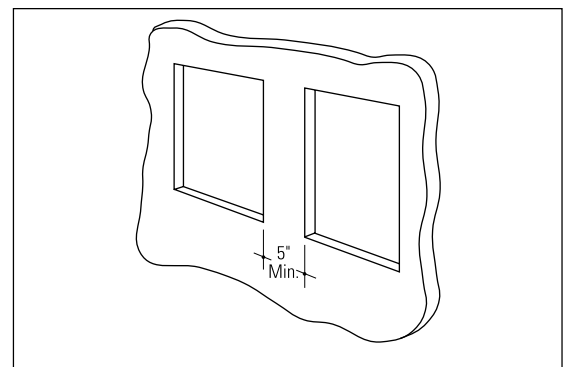

Cabinetry

Built-In Ovens

Tools and materials required

- 2" x 4" lumber for runners
- Saw
- Level
- Phillips screwdriver and wood screws or other hardware for installing runners or shelf to support oven.

Ovens are designed for installation in a cabinet 27" min. wide.

- Cut 2" x 4" runners of appropriate length or solid shelf to support oven.
- Attach runners or solid shelf in opening as shown.
- Runners must be level and rigidly mounted.

Framed cabinet double oven

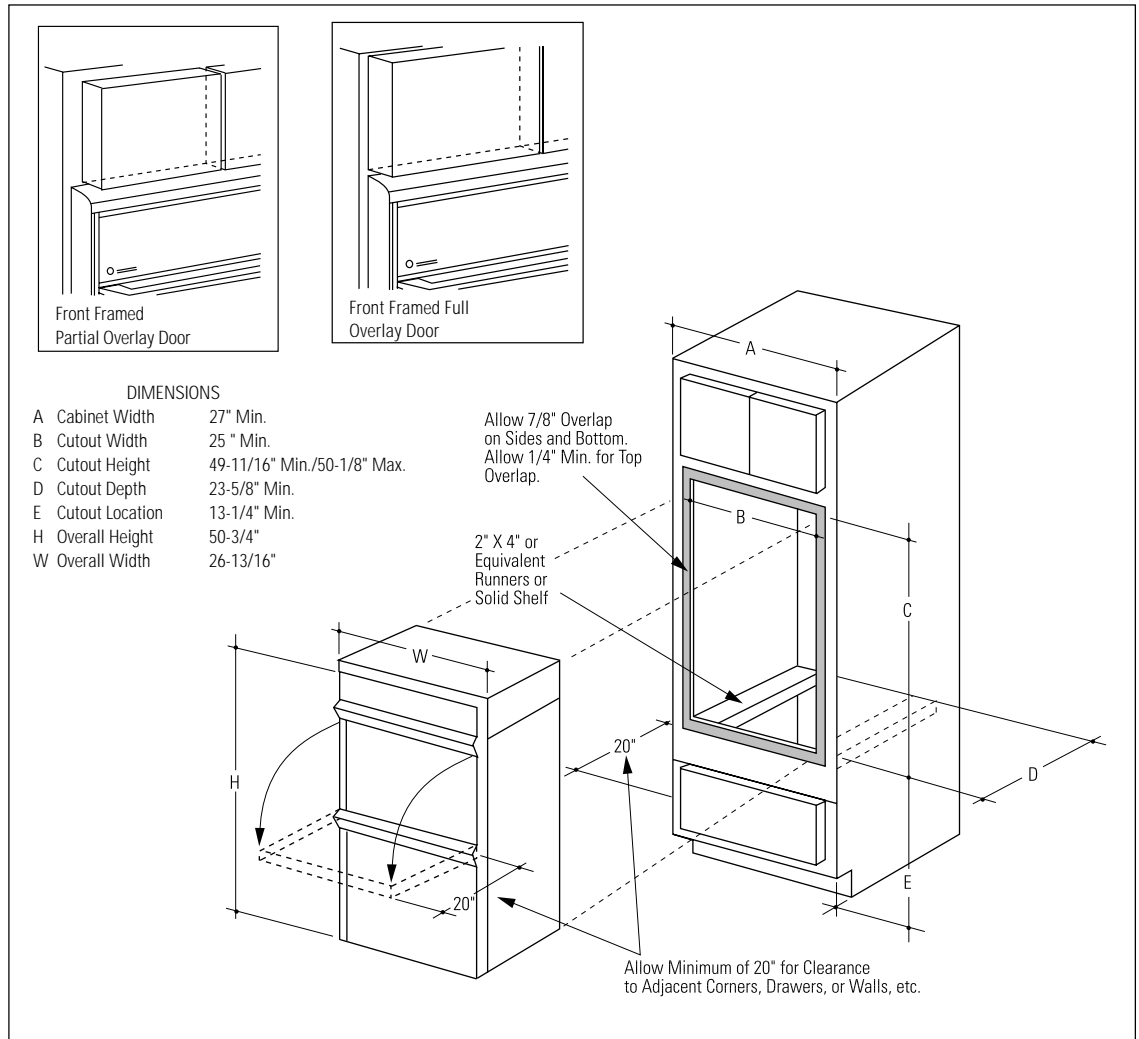

Use the information in this dimension drawing for typical framed cabinets. The front face of the oven will be flush with cabinetry doors or drawers.

Order a double oven cabinet.

Rough opening for double oven must be:

- Depth—23-5/8" min. from inside back to front of cabinet frame.
- Width—25" min.
- Height—49-11/16" min. 50-1/8" max.

- Installing 13-1/4" from floor will place base of upper oven at countertop level.
 - May be more than 13-1/4" from floor, depending upon user preference.
- All Monogram ovens require 7/8" overlap to both sides and bottom. Allow 1/4" min. for top overlap.
- Oven overlaps will conceal all raw edges.

Cabinetry

Built-In Ovens

Framed cabinet
single oven

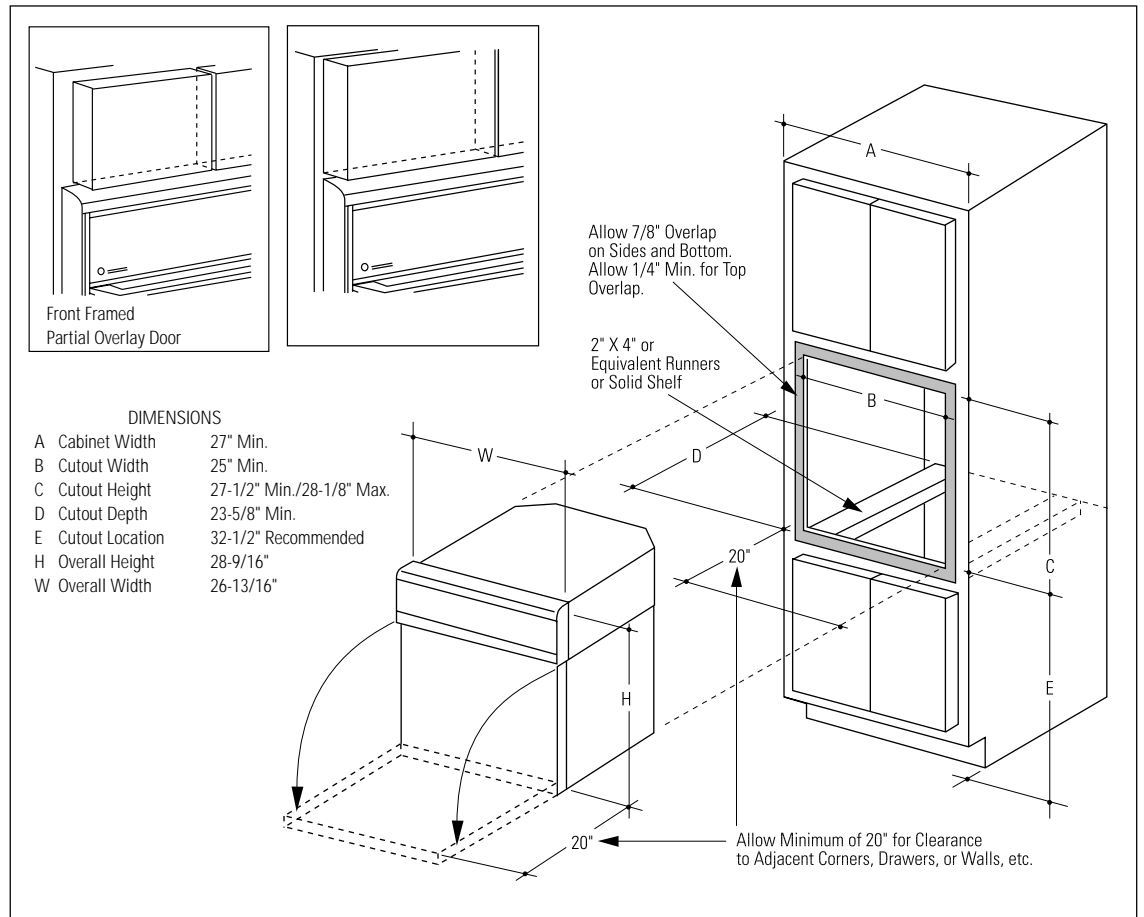

Use the information in this dimension drawing for typical framed cabinets. The front face of the oven will be flush with cabinetry doors or drawers.

Order a single oven cabinet.

Rough opening for single oven must be:

- Depth—23-5/8" min. from inside back to front of cabinet frame.
- Width—25" min.
- Height—27-1/2" min. 28-1/8" max.

- 32-1/2" from floor is recommended to bring oven floor to countertop height.
- All Monogram ovens require 7/8" overlap on both sides and bottom. Allow 1/4" min. for top overlap.
- Oven overlaps will conceal all raw edges.

Cabinetry

Built-In Ovens

Recessed installation:
Front framed cabinets with inset doors and drawers

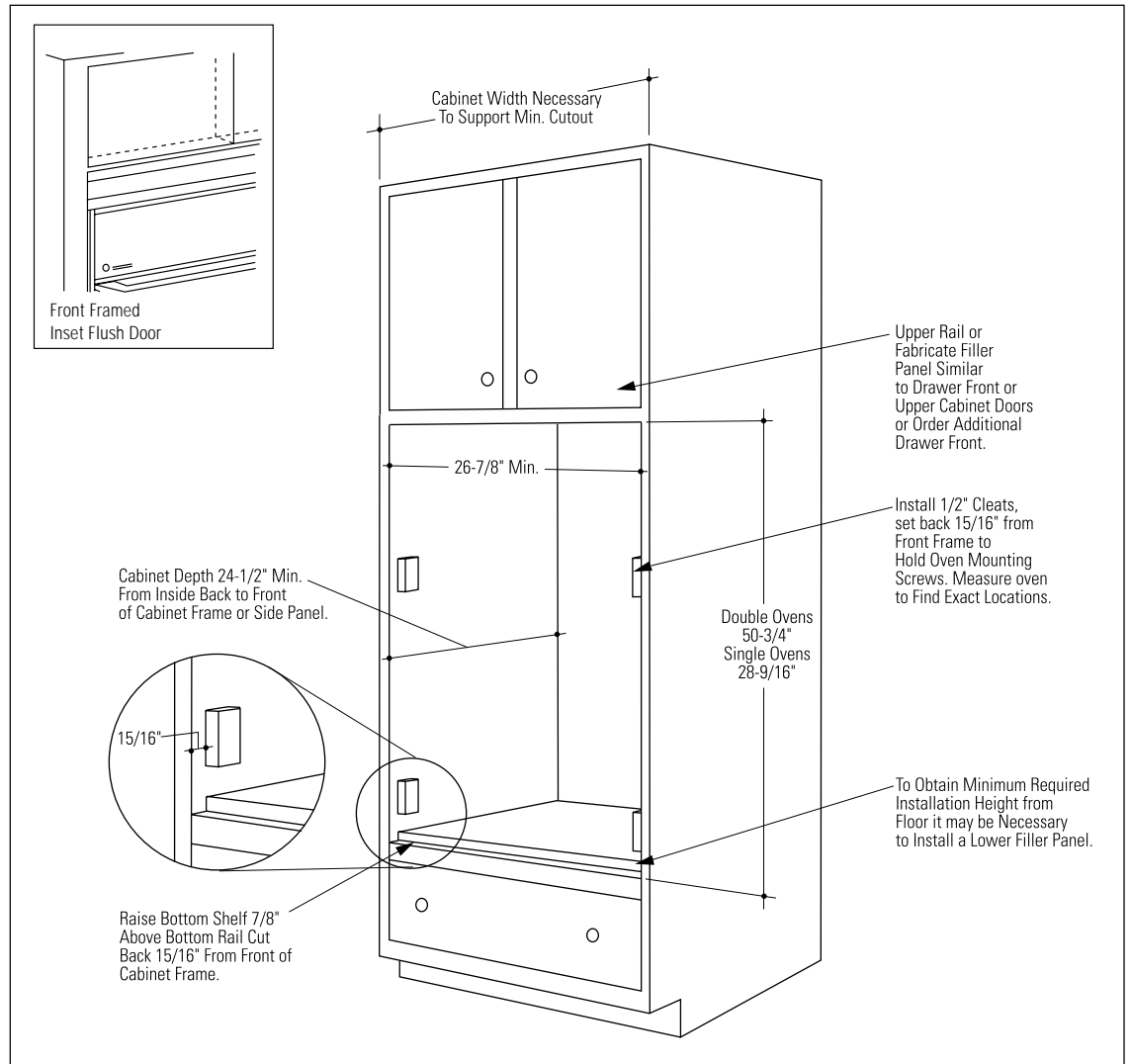

If you are using front framed cabinets with inset doors, these ovens can be installed flush with the front. In this installation the oven is completely recessed into the cabinet.

This is achieved by installing cleats, set back 15/16" from the front frame. The cleats will hold the oven mounting screws. The cabinet must be wide enough to allow 26-7/8" opening. Whenever possible, order the cabinets with the cutout sized to fit the oven.

Provide this information to the cabinet manufacturer in advance.

Rough opening for single and double ovens:

- Depth 24-1/2" min. from inside back to front of cabinet frame.
 - If the cabinet is not 24-1/2" deep, the back of the cabinet should be cutout. The cutout should be minimized in order to maintain structural strength and squareness of the cabinet.
- Height—for double oven 50-3/4".
- Height—for single oven 28-9/16"

Note: Installation in a recessed application is not approved for vinyl covered cabinets.

Cabinetry

Built-In Ovens

Frameless cabinets

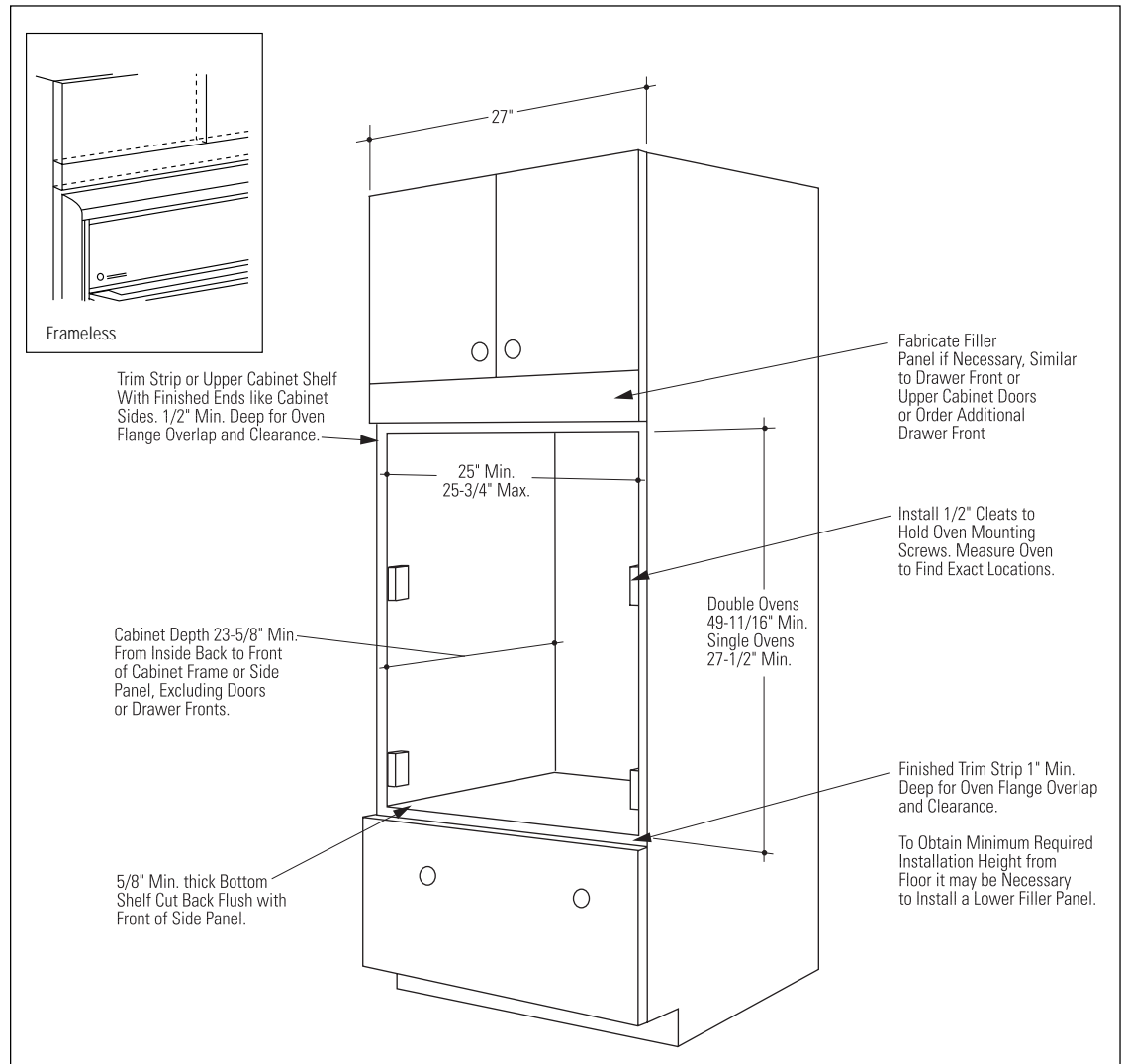

Use the information in this dimension drawing for typical frameless cabinets. The front face of the oven will be flush with cabinetry doors or drawers.

Whenever possible, order 27" frameless cabinet with the cutout sized to fit the oven. If you are using stock cabinets, additional finished filler pieces may be required to cover openings.

Rough opening for single and double ovens:

- Depth—23-5/8" min. from inside back to front of cabinet or side panel, excluding doors or drawer fronts.
 - If the cabinet is not 23-5/8" deep, the back of the cabinet should be cutout. The cutout should be minimized in order to maintain structural strength and squareness of the cabinet.

- Width—25" min.
 - Frameless cabinet inside width may be up to 25-3/4". Add 1/2" cleats to the sides, flush with the front edge of the side panels to accept mounting screws.
- Height—for double oven 49-11/16" min.
- Height—for single oven 27-1/2" min.

Both single and double ovens require 7/8" overlap around edges of opening on both sides and bottom. Allow 1/4" for top overlap.

- Allow 1/8" clearance between top of oven and cabinet door or panel and 1/8" between bottom of oven and cabinet drawer.
- Installation of double oven requires a total height of 51" including clearances at top and bottom.
- Installation of single oven requires a total height of 28-13/16" including clearances.

Cabinetry

Built-In Ovens

Single oven installed below a microwave oven

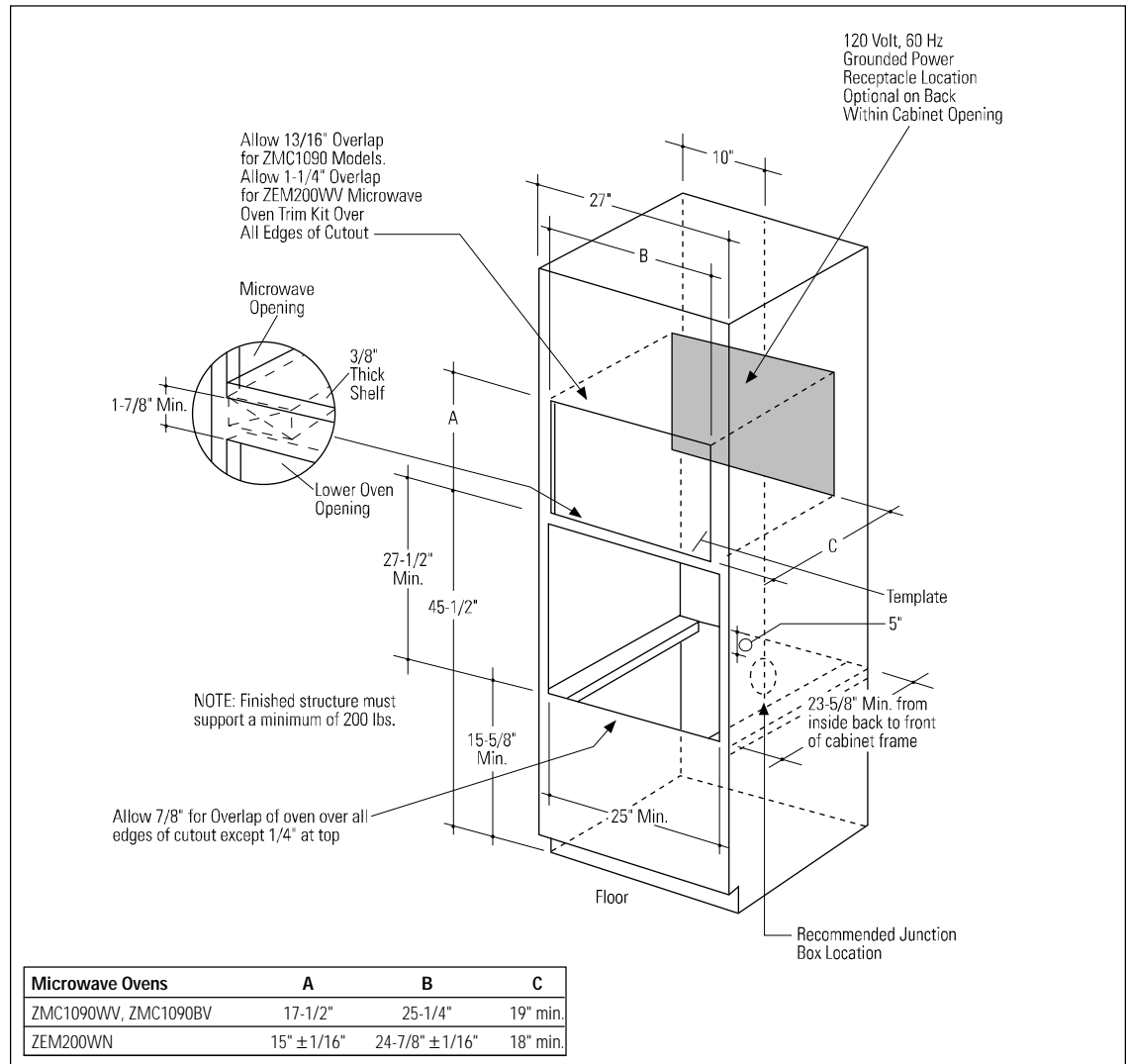

Order a double oven cabinet.

See the chart above for cutout dimensions and receptacle locations for each microwave oven.

- Allow 1-7/8" clearance between microwave oven and single oven, for trim kit or oven overlap.

Models ZMC1090WV and ZMC1090BV do not require trim kits. When installed the outside dimensions will be 26-3/4"W, 18-5/8"H.

- Model ZEM200WV requires JX827WN accessory trim kit. When installed the outside dimensions will be 26-1/8"W, 16-1/4"H.

Install a level base of 3/8" thick plywood, supported by 2"x4" or 1"x2" equivalent runners on all four sides:

- Flush with lower edge of opening and entirely covering floor of opening.
- Finished microwave oven floor must support minimum weight of:
 - 120 pounds for ZMC1090BV/WV.
 - 100 pounds for ZEM200WV.

Cabinetry

Built-In Ovens

Single oven
installed
below a
countertop

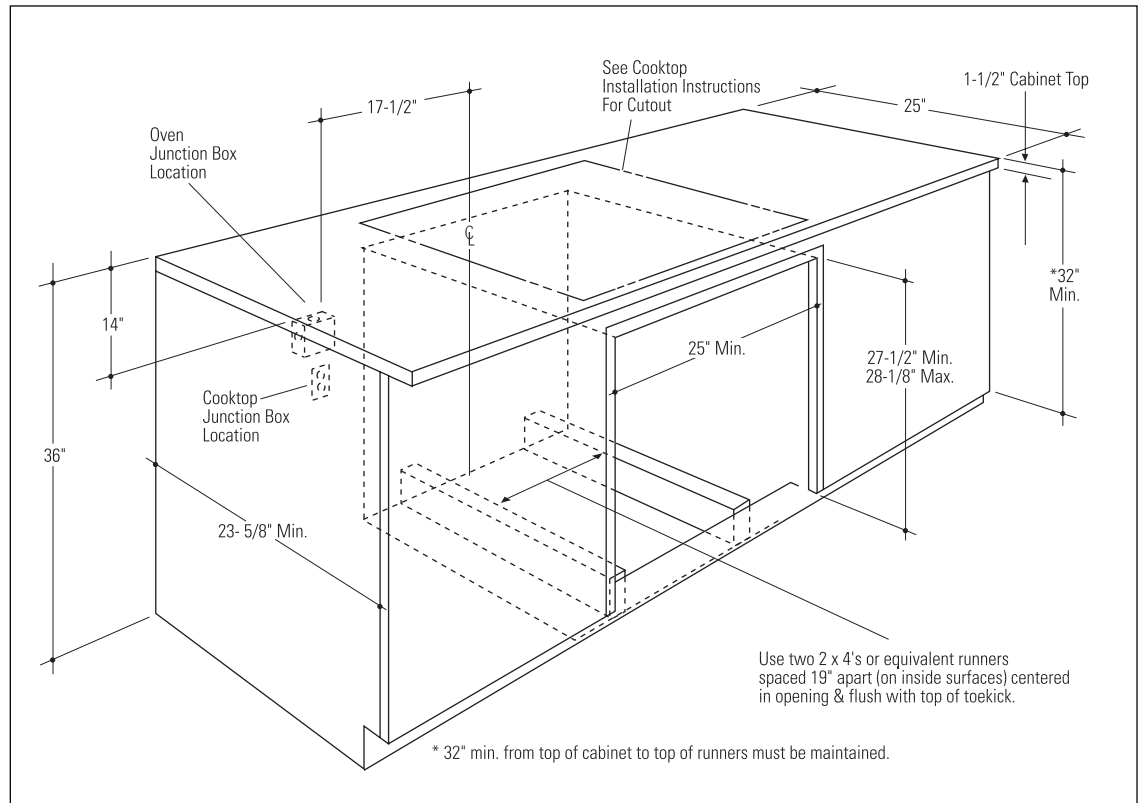

Monogram ovens can be installed below a countertop.

The rough opening of the base cabinet should be:

- Depth—23-5/8" min. from inside back to front of cabinet frame.
- Width—25" min.
- Height—27-1/2" min. 28-1/8" max.

All Monogram single ovens require 7/8" on both sides and bottom. Allow 1/4" min. for top overlap.

- Oven overlaps will conceal raw edges.

Locate the junction box:

- 17-1/2" from the centerline of the opening to the left side.
- 14" below the countertop.

Monogram 36" Halogen and ribbon cooktop can be installed over a single oven. Refer to cooktop installation instructions for cutout.

- Locate the junction box 16" min. below the countertop.

Cabinetry Modification Suggestions

Built-In Ovens

Provide oven supports

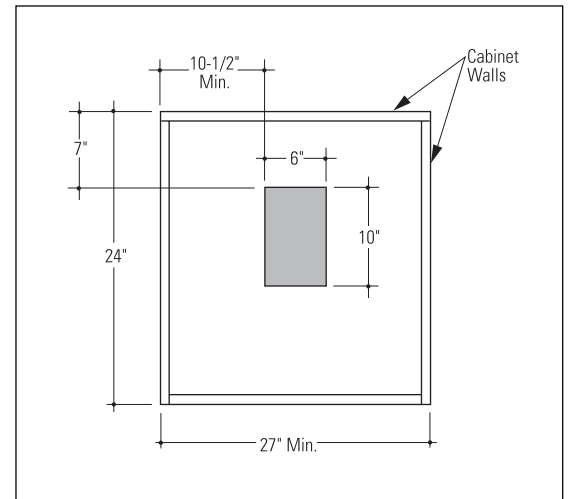
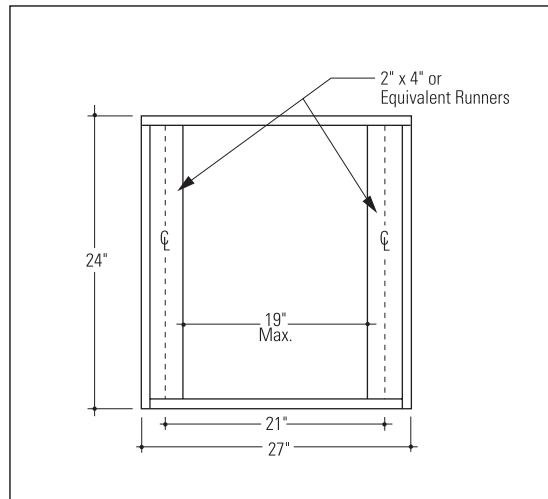

The ovens may be supported by either a solid bottom or 2 x 4 runners.

- The support must be level and rigidly mounted, flush with the bottom edge of the cutout.
- The entire weight of the oven is supported by 2 x 4 runners or the solid floor and must be capable of supporting 200 lbs. for double ovens and 150 lbs. for single ovens.

If a solid bottom is used, a 6" x 10" rectangle must be cut out to allow enough cooling airflow during a self-cleaning operation.

- Cut the solid bottom out of 5/8" min. thick sheeting to fit the inside dimensions of the cabinet. Measure 10-1/2" from left side and 7" from the back wall. Cut the ventilation hole 6" wide and 10" deep.

Install oven supports

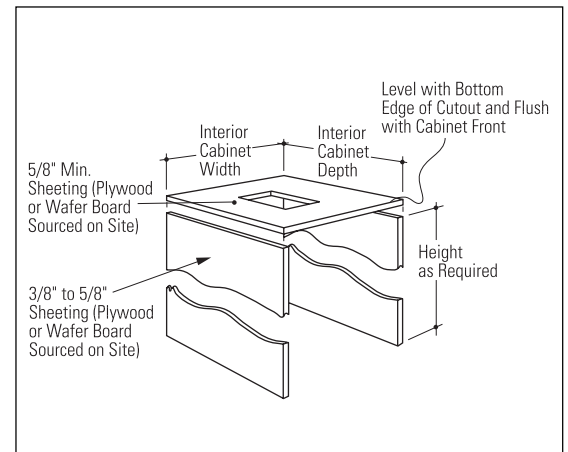
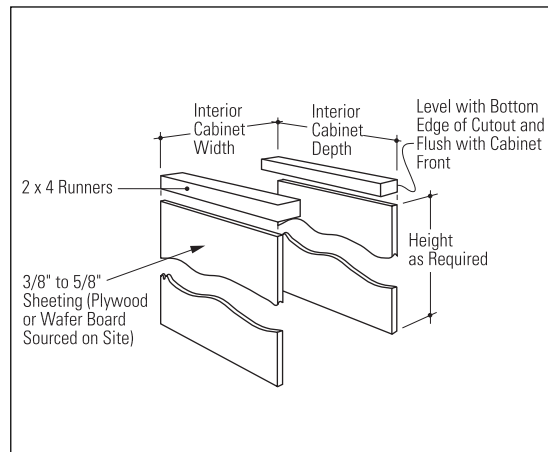

- Measure and mark the location of the runners or solid floor.
 - 13-1/4" from the floor to the top of support, for double ovens.
 - 32-1/2" recommended from the floor to the top of support, for single ovens.

- Cut two pieces of 3/8" to 5/8" thick sheeting, to fit inside cabinet depth and available inside cabinet height. If there is no interference below the cutout, such as drawer runners, the sheeting can rest on the floor. Secure the sheeting strips or pieces to the cabinet walls with screws. Lay 2 x 4 or solid bottom on top of the sheeting and drive screws through the top and into the sheeting.

Determine need for filler panels

If the cabinets being used have an opening that is taller than the maximum dimensions indicated for the ovens, filler panels can be made to fill the gaps. Stock filler strips are usually available or for larger gaps order an extra drawer front. Drawer fronts are recommended because they will match the cabinetry and have finished edges. Any cut edges will be seen and should be finished.

Frameless cabinets usually come with a front panel covering the opening. For the optimum finished look, this panel can be removed and used to construct filler panels.

The oven support floor and supports should be installed at the required locations.

If there is a gap between the oven support floor and the bottom of the opening, a bottom filler panel should be constructed to fill the gap.

Measure from the oven support floor to the top of the opening. If the opening height is larger than the maximum cutout height, a filler panel should be constructed to fill the gap.

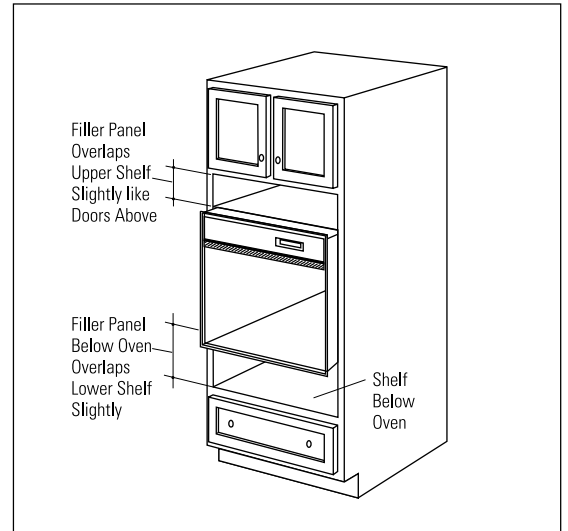

Filler panel construction

We suggest that the filler panel be constructed using 4 pieces:

- Appearance panel to match doors and drawers.
- A rail which will be covered by the oven overlaps and conceal any slight gap between the top or bottom of the oven and the start of the filler panel. The face of the rail should be made of finished matching material; the cut edges and ends do not need to be finished.
- Cleats which will be used to secure the filler panel and rail to the cabinet. One for each side.

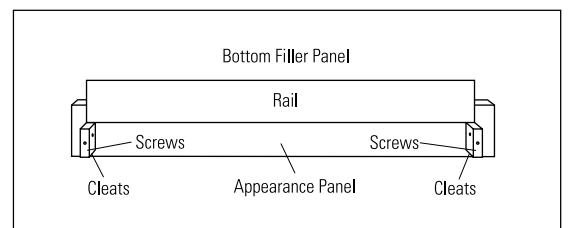
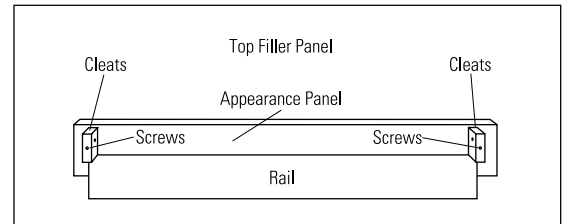

Cabinetry Modification Suggestions

Built-In Ovens

Cut rail for filler panel

Cut the rail out of finished material:

- The width should match cabinet opening width.
- The height of the top rail should be enough to securely attach the rail to the appearance panel, plus 1/4" oven trim overlap.
- The height of the bottom rail should be enough to securely attach the rail to the appearance panel, plus 7/8" oven trim overlap.
- The height of both the top and bottom rails should be adjusted depending upon the height of the gap to be filled or to enhance appearance.

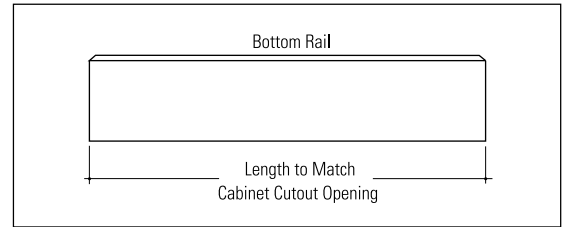
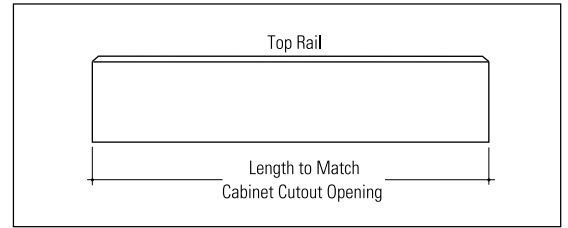

Cut appearance panel

Use drawer fronts for appearance panels or cut finished material and finish raw edges.

- The appearance panel width should match drawer fronts or doors.
- Make the appearance panel appropriate height to fill the gap above or below the oven, allowing for reveals and overlaps to match existing drawers or doors.

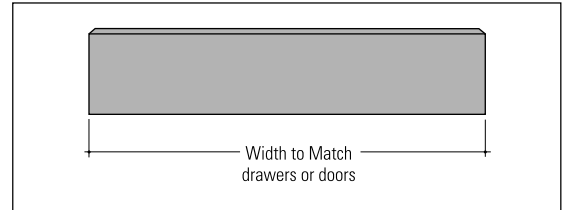

Determine location of cleats

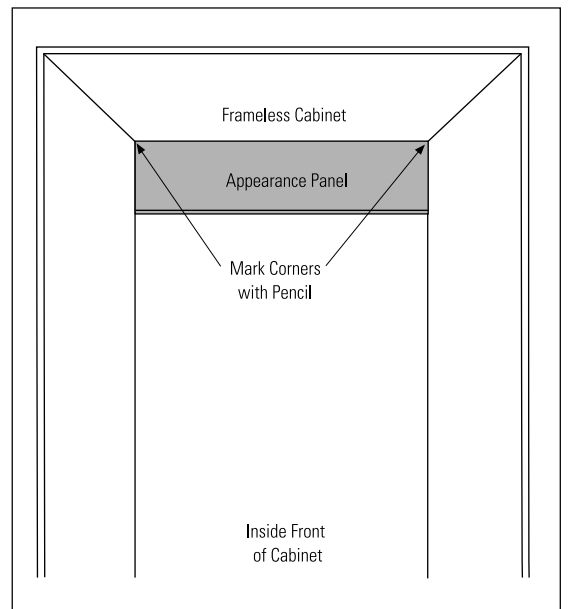
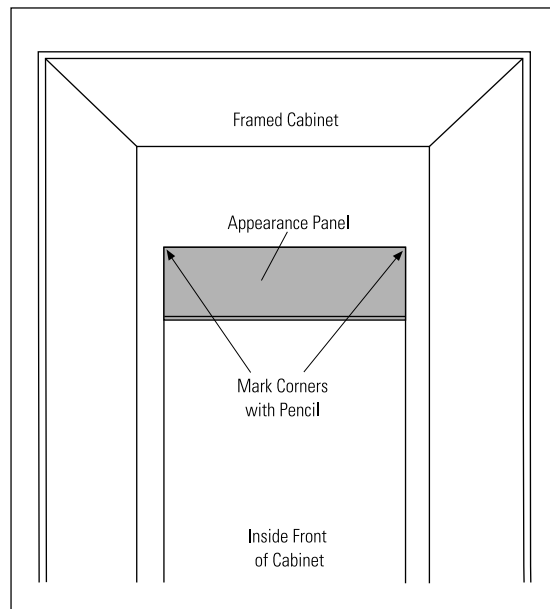

- To find the exact position of the cleats, place the appearance panel onto the cabinet in desired position and align to match the other drawers and doors.

- Use a pencil to mark the back side of the panel where it meets the cabinet corners.

Cabinetry Modifications Suggestions

Built-In Ovens

Cut and secure cleats to filler panel

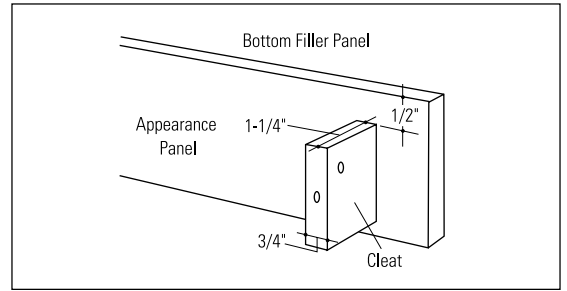
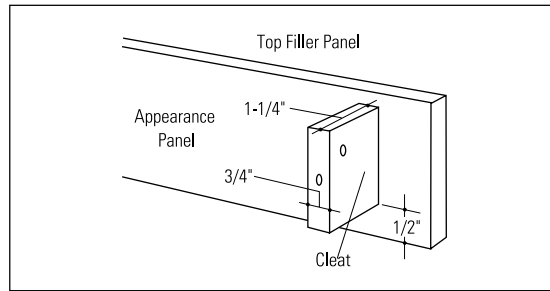

For the top filler panel:

- Cut 2 cleats out of 3/4" thick material, approximately 1-1/4" wide.
- Cut the cleats to a length leaving approximately 1/2" at the bottom of the appearance panel to attach the rail.
- Position the outside edge and top of the cleat against the corner pencil marks.
- Secure the cleat to the appearance panel with screws.

Note: The screws should be long enough to secure the cleats to the filler panel without penetrating the appearance side.

For the bottom filler panel:

- Cut 2 cleats out of 3/4" thick material, approximately 1-1/4" wide.
- Cut the cleats to a length leaving approximately 1/2" at the top of the filler panel to attach the rail.
- Position the outside edge and bottom of the cleat against the corner pencil marks.
- Secure the cleat to the appearance panel with screws.

Note: If appearance panel is very narrow, cleats can be attached to the rail.

Secure rail to appearance panel

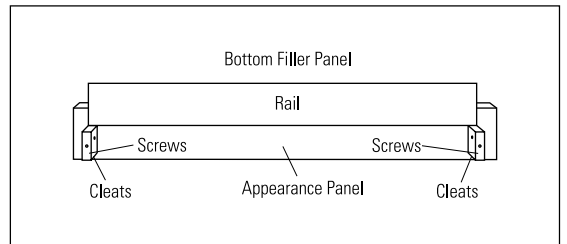
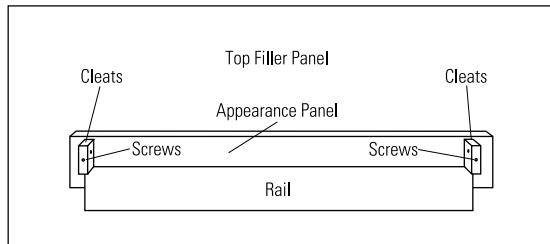

- Place rail against cleats and flush with the outside edges of the cleats. Secure with wood screws. If the appearance panel is very narrow, cleats can be attached to the rail.

Note: The screws should be long enough to secure rail to the filler panel without penetrating the finished face of the filler panel.

Secure assembled filler panel to cabinet

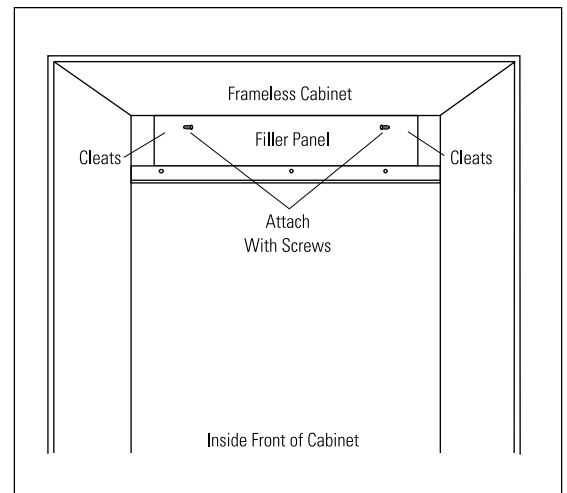
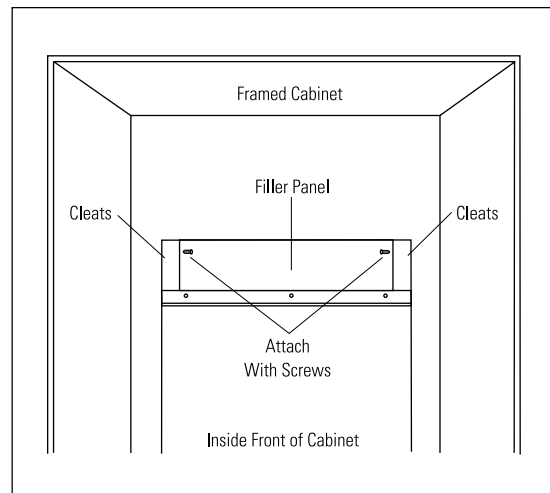

- Place filler panel in proper position. To attain proper relationship to adjacent drawers and doors

you may need to space the filler panel out from the cabinet face/edges using drawer bumpers or other spacers.

Installation

Built-In Ovens

Tools and materials required

- Outlet box
- Electrical cable—3-conductor or 4-conductor wire—as required by local codes
- Flexible power cable connector
- Electrician's pliers

Note: Do not use an extension cord with these appliances.

Monogram built-in single and double ovens require a separate, properly grounded 3-wire 120/208 or 120/240 volt, 60 Hz power supply, protected by a time delay fuse or circuit breaker. Ovens are supplied with a flexible power cable, which must be attached to a junction box. The cable length is 48" for both single and double conventional ovens. The cable length for convection type ovens is 54".

Double ovens are rated 6.8 KW at 240 volt, and 5.1 KW at 208 volt.

Single ovens are rated 3.4 KW at 240 volt, and 2.6 KW at 208 volt.

Electrical locations

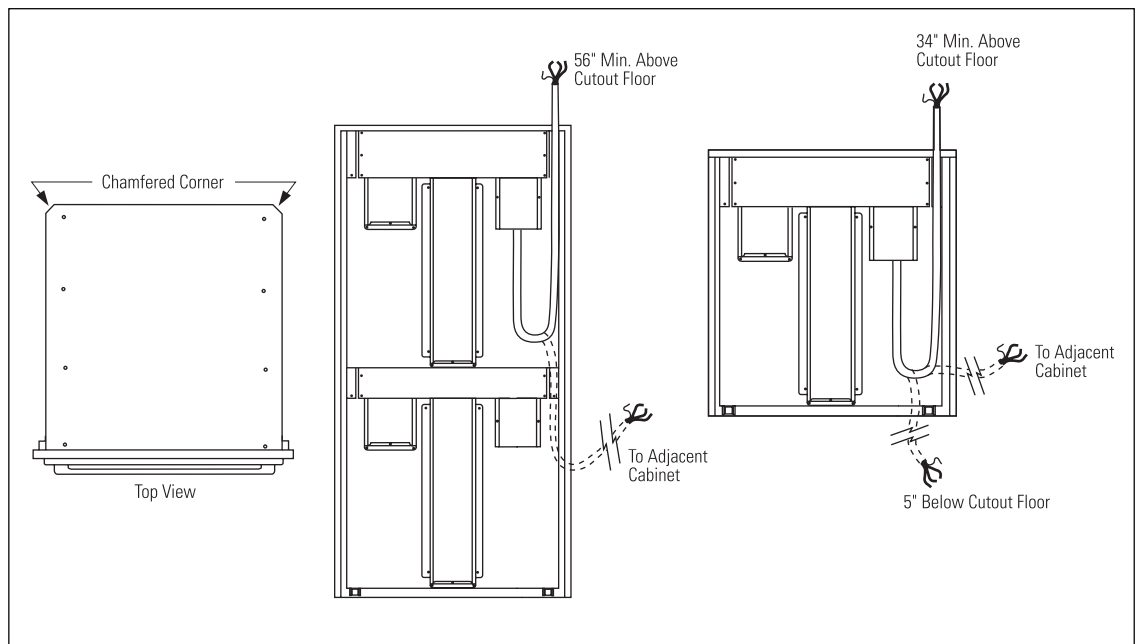

The back of the ovens have chamfered corners which provide a "chase" for the conduit when installing a junction box above or below the oven(s).

The conduit is located on the back of the oven, approximately 10" from the right side.

For double oven:

- Locate and install the junction box within reach of the power cord.
 - Approximately 10" from the **left side** of opening
 - 56" minimum above the cutout floor
 - or, through the **left side** of cabinet wall into adjacent cabinet.

For single oven:

- Locate and install the junction box within reach of the power cord.
 - Approximately 10" from **left side** of opening.
 - At least 5" below the cutout floor
 - Or 34" minimum above the cutout floor
 - or, through the **left side** of cabinet wall into adjacent cabinet.

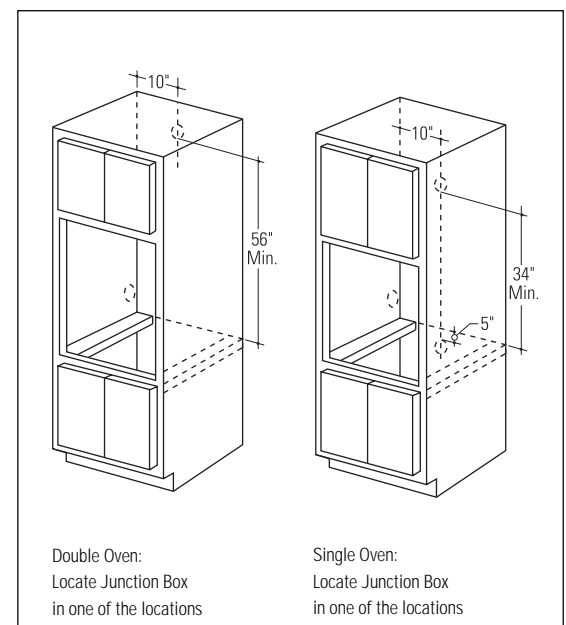

Installation

Built-In Ovens

Finalize installation

Caution: Do not lift oven or oven door by handle. Door glass breakage or handle damage may occur. Glass surface of door face extends beyond door frame on each side; be careful not to impact this exposed glass.

Caution: When door is removed and hinge arms are at stop position, do not bump or try to move hinge arms. Hinges could snap back, causing an injury to hands or damage to porcelain surface.

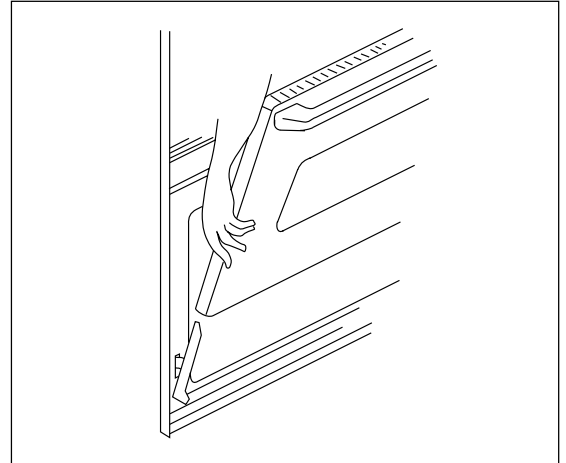

Remove oven door:

- Open the door to stop position.
- Grasp each side of door, lifting up and off the hinges.
- Cover hinges with toweling while working in oven area.

Note: The lower front trim is packed separately and should not be attached until the oven is installed and secured to the installation opening.

Install lower oven trim

- Secure lower front trim to the front frame with 3 Phillips head screws provided.
- Secure trim to the side trim with 2 #20 torx head screws as illustrated.

⚠ CAUTION

The bottom trim provides an opening for cooling air to enter the cabinet. This opening should never be blocked.

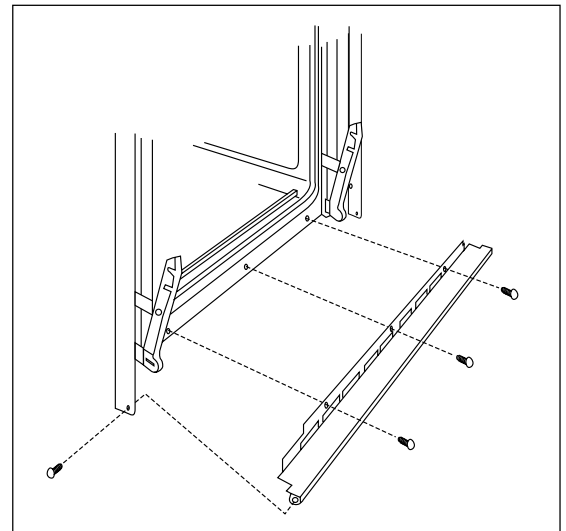

Route cable through cutout

Note: It is best that 2 people perform this step: one to hold oven in position and one to feed cable.

With oven in front of cabinet opening:

- Start feeding the flexible power cable through cutout.
- Insert oven 3/4 way into cabinet opening. Continue to feed flexible power cable while sliding oven into place. This is to insure that the flexible power cable will not get trapped between the back of the oven and the back of the cabinet wall.

⚠ CAUTION

Be sure you do not tip the unit forward during installation or you may bend the Lower Side Trim.

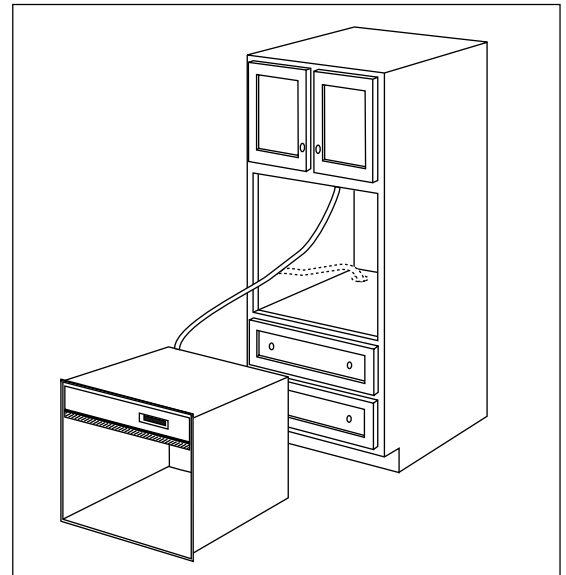

Installation

Built-In Ovens

Secure oven to cabinet

- Slide oven into cabinet opening.
- Drill 3/32" pilot holes through mounting holes in oven front frame. (2 screw holes for single ovens, 4 screw holes for double ovens.)
- Secure oven in place with screws furnished. (Use drywall screws if cabinet is particulate board).

⚠ WARNING
Securely fasten oven to cabinet using the screws provided. Failure to do so could cause the oven to move or tip during use and result in personal injury.

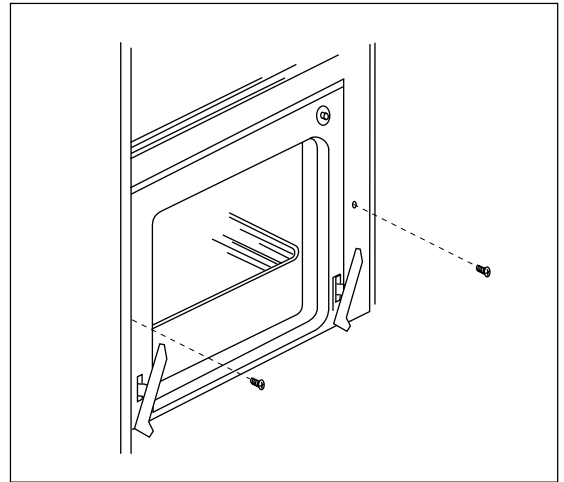

Replace the oven door

- Remove toweling. The hinges should still be in stop position.
- Slide the door down onto the hinges as far as it will go. Close the door.

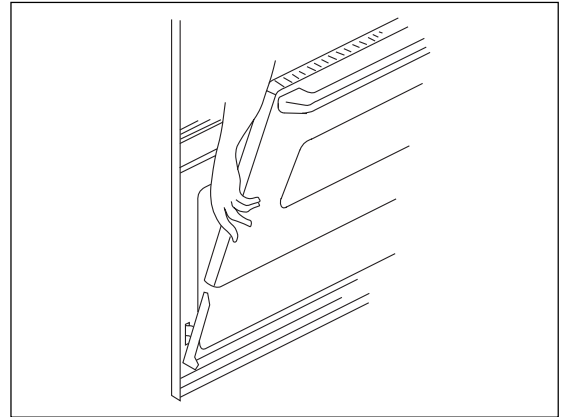

Connect electrical

- With oven installed:
- Connect oven power cable to junction box, using flexible power cable connector.
 - Be sure connections are secure.

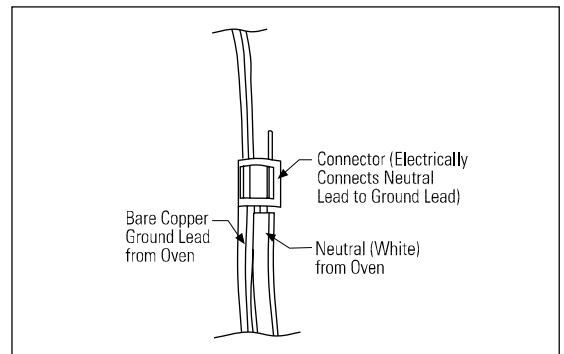

Installation

Built-In Ovens

Connect electrical
(continued)

- When connecting to a 3-conductor branch circuit:
 - Connect oven red lead to branch circuit red lead.
 - Connect oven black lead to branch circuit black lead.
 - Connect oven bare copper conductor and white lead to branch circuit neutral lead (white or gray).

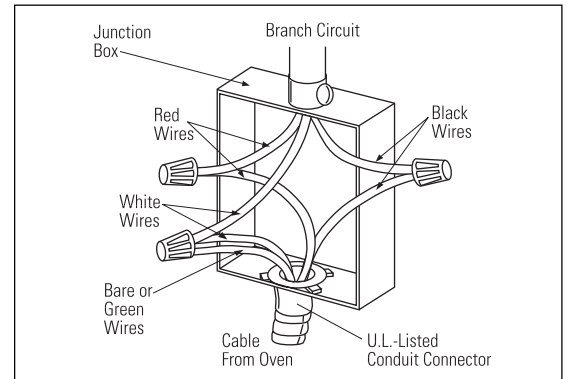

- When connecting to a 4-conductor branch circuit:
 - Connect oven red lead to branch circuit red lead.
 - Connect oven black lead to branch circuit black lead.
 - Break connection between oven white lead and oven bare copper conductor.
 - Connect oven white lead to branch circuit neutral lead (white or gray).
 - Connect oven bare copper conductor to branch circuit ground lead (green or bare copper).

Note: Aluminum house wiring requires use of special aluminum-to-copper connectors. Follow manufacturer's instructions carefully.

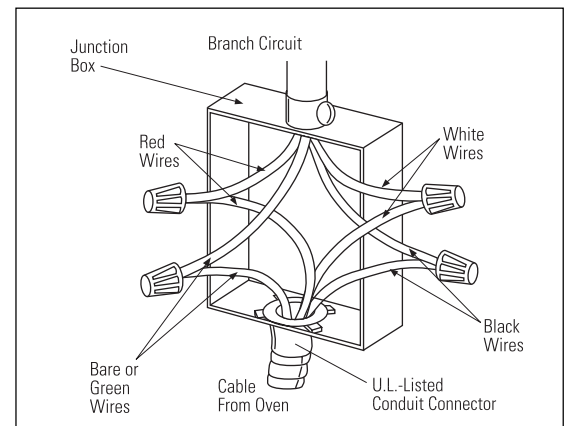

NOTE: While performing installations described in this book, safety glasses or goggles should be worn.

To obtain specific information concerning any Monogram product or service, call GE Answer Center® consumer information service at 800.626.2000—any time, day or night.

For Monogram local service in your area, call 1-800-444-1845.

NOTE: Product improvement is a continuing endeavor at General Electric. Therefore, materials, appearance and specifications are subject to change without notice.

Pub. No. 49-8804
© 1996 GE Appliances
(N.D. 616) 9/96



General Electric Company
Louisville, KY 40225