

B u i l t - I n E l e c t r i c O v e n

User information

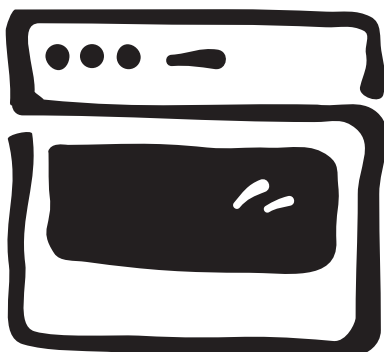

EOB5610

Dear Customer,

Please read this instruction book carefully.

Above all, please observe the “safety” section on the first few pages. Please retain this instruction book for later reference. Pass them on to any subsequent owners of the appliance.

The following symbols are used in the text:



Safety Instructions

Warning: Information concerning your personal safety.

Important: Information on how to avoid damaging the appliance.



Information and practical tips



Environmental information

1. These numbers indicate step by step how to use the appliance.

2....

3....

These operating instructions contain information on steps you can take yourself to rectify a possible malfunction. Refer to the section “What to do if...”.

Contents

Operating Instructions	5
Safety	5
Disposal	6
Description of the Appliance	7
General Overview	7
Control Panel	8
Oven Features	8
Oven Accessories	9
Before using for the first time	10
Initial Cleaning	10
Operating the Oven	11
Switching the Oven On and Off	11
Oven Functions	12
Attaching/Removing the Grill Pan Handle	13
Minute Minder	14
Usage, Tables and Tips	15
Baking	15
Baking table	17
Roasting	20
Roasting Table	21
Grilling	23
Grilling Table	24
Defrosting	25
Defrosting table	25
Drying with the Fan Oven	26
Cleaning and care	27
Exterior of the Appliance	27
Oven Interior	27
Accessories	27
Shelf Support Rails	28
Oven Lighting	29
Oven Roof	30
Oven Door	31
Oven Door Glass	32
What to do if	33
Technical Data	34
Oven Interior Dimensions	34
Regulations, Standards, Directives	34

Installation Instructions 35
Safety Instructions for the Installer 35
Electrical Connection 36
Guarantee Conditions 41
Index 46
Service and Spare Parts 47

Operating Instructions



Safety

Electrical Safety

- The appliance may only be connected by a **qualified electrician / competent person**.
- In the event of any faults or damage to the appliance: remove fuses or switch off.
- It is **not permissible** to clean the appliance with a steam or high pressure cleaner for safety reasons!
- **Repairs** to the appliance may **only be carried out by specialists**. Repairs carried out by inexperienced persons may cause injury or serious malfunctioning. If your appliance needs repairing, please contact your local Service Force Centre or your specialist dealer.

Child Safety

- Never leave children unsupervised when the appliance is in use.

Safety whilst Using

- This appliance is intended to be used for cooking, frying and baking food in the home.
- Take care when connecting electric appliances to sockets nearby. Do **not** allow connecting leads to come into contact with hot rings or to catch beneath the hot oven door.
- **Warning: Risk of burns!** The interior of the oven becomes hot during use.
- Using ingredients containing alcohol in the oven may create an alcohol-air mixture that is easily ignited. In this case, open the door carefully. Do not have embers, sparks or naked flames in the vicinity when opening the door.

To Avoid Damaging Your Appliance

- Do not line your oven with aluminium foil and do not place a baking tray or dish on the oven floor, otherwise the oven enamel will be damaged by the resulting build up of heat.
- Juice from fruit that drips from baking trays will leave marks that cannot be removed. For very moist cakes, use the universal baking tray.
- Do not put any weight on the oven door when it is open.
- Never pour water directly into the hot oven. The enamel may be damaged.
- Using force, especially on the edges of the front glass panel, may break the glass.
- Do not store inflammable objects in the oven. They may ignite when the oven is switched on.
- Do not store moist food in the oven. The enamel may be damaged.



Disposal

Disposing of the packaging material

All materials used can be fully recycled.

Plastics are marked as follows:

- >PE< for polyethylene, as used for the outer wrapping and the bags inside.
- >PS< for polystyrene foam, e.g., as used for the padding materials. They are completely free of CFCs.

Disposal of old appliances



Warning: Before disposing of old appliances please make them inoperable so that they cannot be the source of danger.

To do this, disconnect the appliance from the mains supply and remove the mains lead.

To protect the environment, it is important that worn out appliances are disposed of in the correct manner.

- The appliance must not be disposed of with household rubbish.
- You can obtain information about collection dates or public refuse disposal sites from your local Council or Environmental Health Office.

Description of the Appliance

General Overview

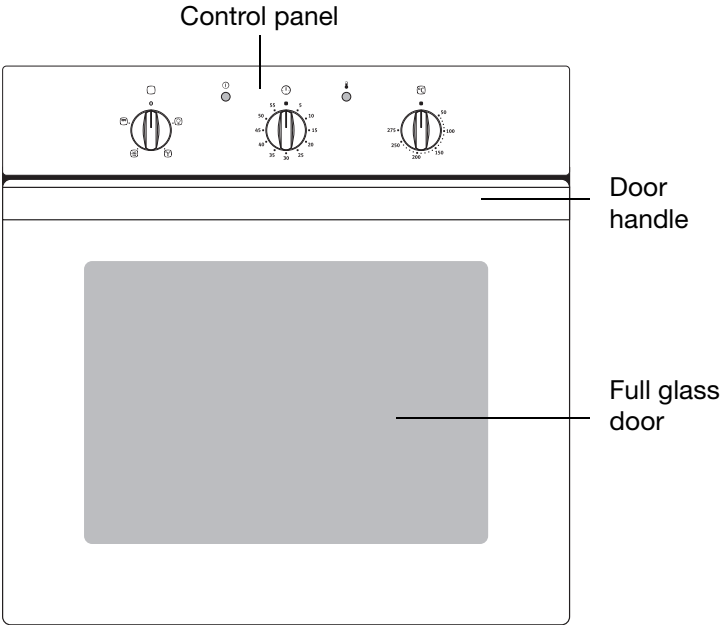

Control Panel

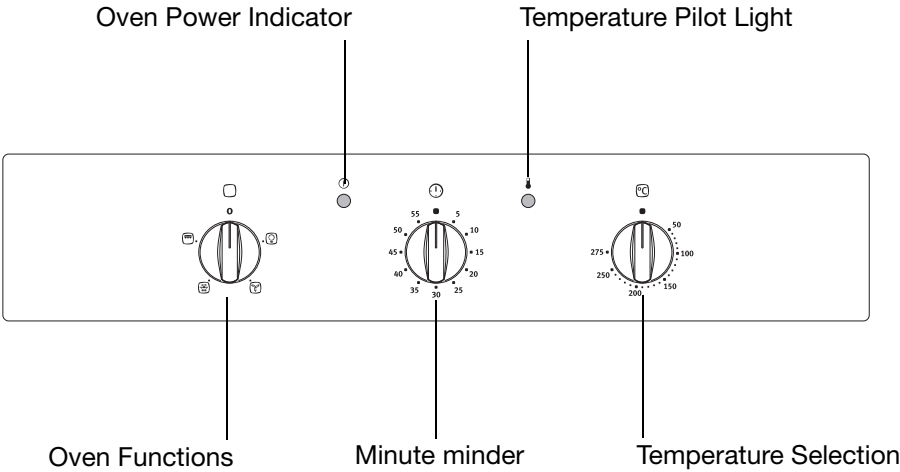

Oven Features

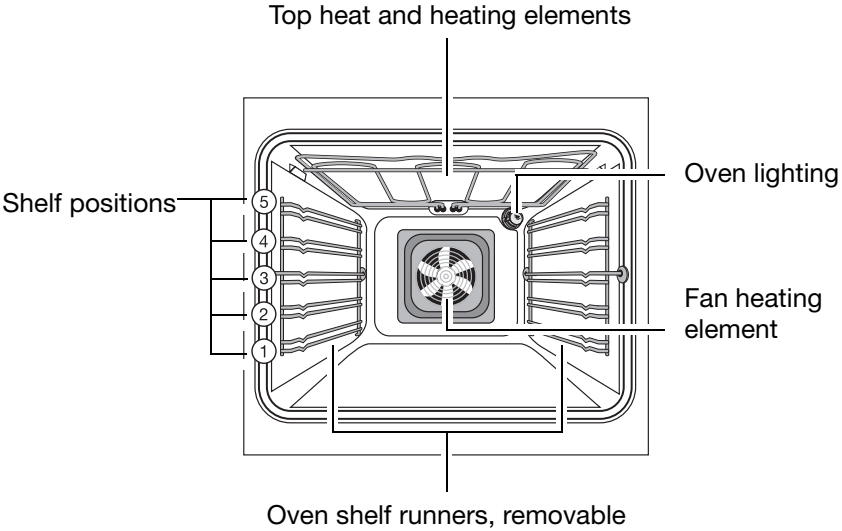

Oven Accessories

Combination shelf

For dishes, cake tins, items for roasting and grilling.

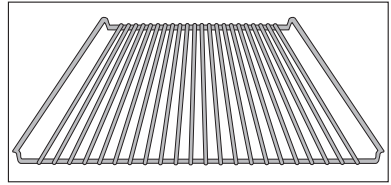

Grill pan with handle

Support for the grill tray as a collecting vessel for fat

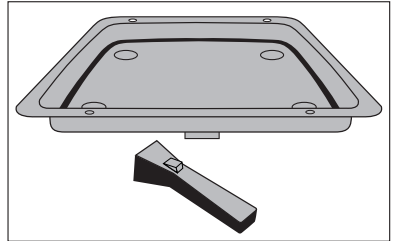

Grill tray

Insert for the grill pan for grilling smaller amounts of food

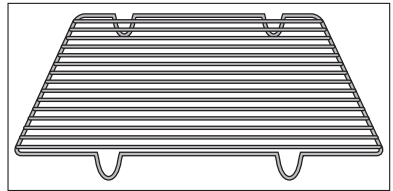

Before using for the first time

Initial Cleaning

Before using the oven for the first time you should clean it thoroughly.



Caution: Do not use any caustic, abrasive cleaners! The surface could be damaged.



To clean any metal front panels use commercially available cleaning agents.

1. Turn the oven function switch to oven lighting .
2. Remove all accessories and the shelf support rails and wash them with warm water and washing up liquid.
3. Then wash out the oven with warm water and washing-up liquid and dry.
4. Wipe the front of the appliance with a damp cloth.

Operating the Oven

Switching the Oven On and Off

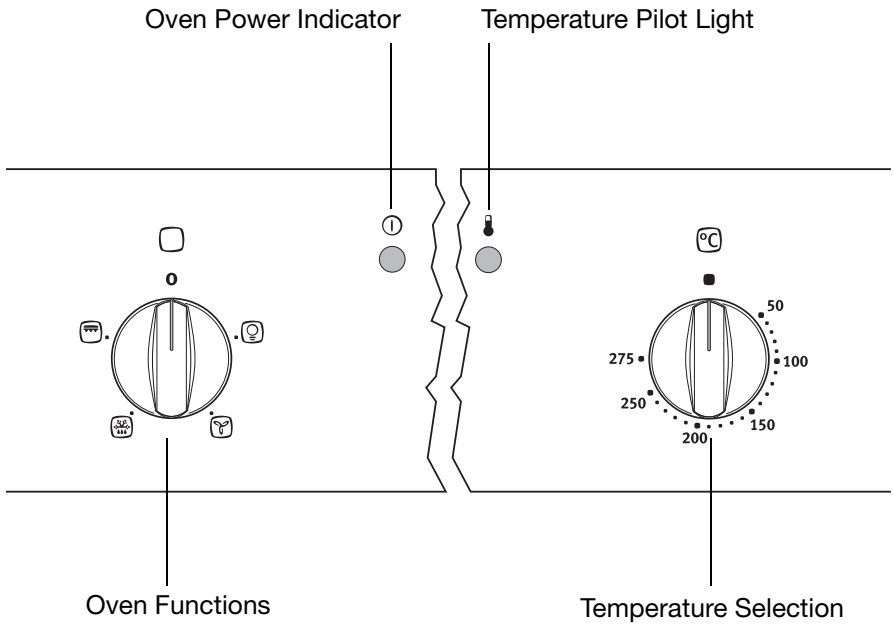

1. Turn the oven functions switch to the required function.
2. Turn the temperature selection switch to the required temperature.
The red oven power indicator is illuminated whilst the oven is in use.
The red temperature pilot light is only illuminated whilst the oven is heating up.
3. To switch off the oven, turn the oven functions switch and the temperature selection switch to the zero position.



Cooling fan

When the oven is switched on, the fan comes on automatically to keep the surfaces of the appliance cool. When the oven is switched off, the fan continues to operate to cool the appliance down, then switches itself off.

Oven Functions

The oven has the following functions:

Oven lighting

With this function you can **illuminate** the oven interior e.g. for cleaning.
The heating element is not in use.

Fan Oven

For **roasting and baking** on **up to three levels** simultaneously.
Set oven temperatures 20-40 °C lower than when using conventional.
The fan heating element is used and in addition the fan is switched on.

Defrost

To **begin to thaw and to defrost** such items as flan, butter, bread, fruit or other **frozen foods**.

For this function the fan operates **without** heating.

Grill

For **grilling** flat foods in **larger quantities**, such as steaks, escalopes, fish or for **toasting**.

Top heat and the grill element are used.

Attaching/Removing the Grill Pan Handle

The handle is particularly useful for removing the grill pan and tray more easily from the hot oven.

Attaching the handle

Insert **the handle** at an angle from above into the recess in the side of the grill pan (1) lift it gently and then lower it (2) until you hear it click into place.



Warning: Risk of burning!

Important: Check that the handle is securely attached!

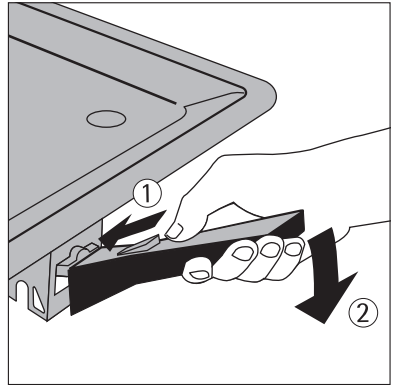

Removing the handle

Press the release button on the top of the handle (1) and lift up the handle (2) to remove it.



Important: Never leave the handle in the heated oven! Overheating can cause the handle to deform or break, and may cause an injury.

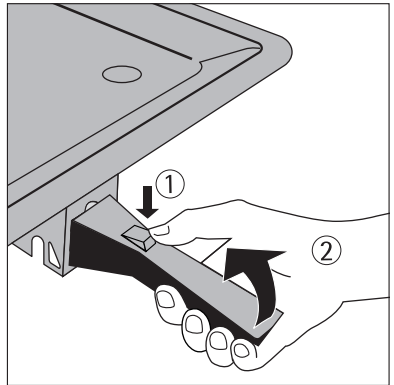

Minute Minder

This function has no effect on the oven operation.

Turn the control knob to 60 minutes, then turn it back to the desired length of time. (60 minutes maximum).

A signal is sounded when the set time has elapsed.

To change your setting, just turn the knob to the desired duration.

To stop the timer before the set time has elapsed, simply turn the knob back to OFF.

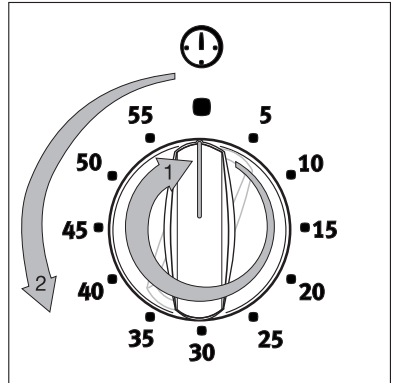

Usage, Tables and Tips

Baking

Use the fan  oven function to bake.

Baking tins

- Metal, glass and ceramic tins are suitable for use with the fan oven function .

Shelf position

- When using the fan oven  function you are able to bake dry, flat items on up to 3 baking trays simultaneously.

1 baking tray:
e.g. shelf level 3

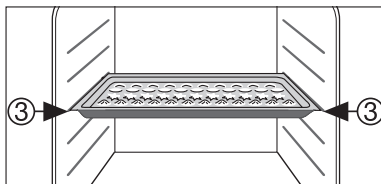

1 baking tin:
e.g. shelf level 1

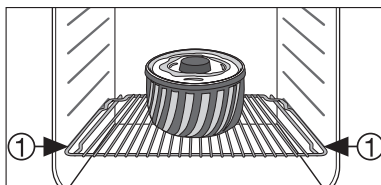

2 baking trays:
Shelf level 1 and 4

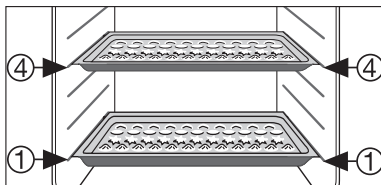

3 baking trays:
Shelf levels 1, 3 and 5

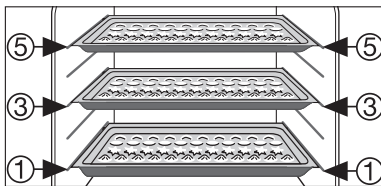

General tips

- Be sure to count the shelf positions from bottom to top.
- Insert the baking tray so that the slope is at the front.
- Always place cake tins in the middle of the shelf.
- When using the fan oven  function you are also able to bake two tins side by side on a rack simultaneously. This increases the baking time only slightly.



When frozen foods are used the trays inserted may distort during cooking. This is due to the large difference in temperature between the freezing temperature and the temperature in the oven. Once the trays have cooled the distortion will disappear again.

Notes about the baking table

In the charts you will find the temperature indications, cooking times and shelf levels required for a selection of dishes.

- The temperatures and baking times are to be used as a guide only, as they depend on the composition of the dough, the amount, and the type of cake tin.
- We recommend setting the oven to the lower temperature the first time and to select a higher temperature only if required, e.g. if additional browning is desired or if the baking time is too long.
- Should you be unable to find any exact indications for one of your own recipes, use those given for a similar item as a guide.
- When baking cakes on baking trays or in tins on more than one shelf level the baking time may need to be lengthened by 10-15 minutes.
- Moist items (e.g. pizzas, cakes with fruit toppings etc.) should be cooked on one level only.
- Differences in height between the items baked may mean that at the beginning of the baking period they are browned to different degrees. In such case **please do not change the temperature set**. Differences in the degree of browning will even out during the course of the baking period.



Where the baking time required is relatively long, you can switch off the oven approx. 10 minutes prior to the end of the baking period thereby making use of the residual heat.

Unless otherwise stated, the charts are applicable for use when placing items into a cold oven.

Baking table

The baking times given are to be used as a guide only.

The recommended cooking methods, shelf level and temperatures are **printed in bold**.

Item type	Fan Oven 		Baking time in minutes
	Temperature in °C	Shelf position	
Batter			
Ring cake	150-170	1	50-70
Loaf cake (log tin)	140-160	1	70-80
Base for fruit slice	150-170	3	20-25
Apple cake, very thin crust	150-170	1	45-60
Shortcrust			
Cheesecake	140-160	1	60-90 + 10 min. residual heat
Covered fruit tart	150-170	1	50-60
Puff pastry			
French apple cake	150-170*	1	40-50
Sponge mixture			
Sponge cake (DIN)	150-170	1	25-40
Base for fruit slice	150-160*	3	25-30
Sponge roll	150-170*	3	10-15
Small sponge cakes (Fairy/Queen)	160-180	3	25-30
Yeast			
Ring cake	150-170	1	45-60
Yeast roll/-ring	150-170	3	30-40
Streusel cake	150-170	3	20-40
Apple-streusel cake (DIN)	150-170	3	35-50
Cheesecake (tray-size)	150-170	3	45-50

Item type	Fan Oven 		Baking time in minutes
	Temperature in °C	Shelf position	
Christmas fruit cake (500g flour)	150-170*	3	40-70
Pizza (round pizza tray)	230-250*	1	10-25
Biscuits			
Meringues	80-90*	3	150-180
Macaroons	100-120	3	20-30
Shortbread biscuits	140-160	4+1 1+5+3	15-30
Nut biscuits	---	---	25-35
Puff pastry items	160-180*	4+1	20-30
Yeast rolls, small	160-180*	4+1	20-40
Choux pastry			
Cream puffs	160-180	4+2	25-40
rubbed dough types			
Swiss apple tart	---	---	35-50
Swiss-style cheese tart	---	---	40-50
Spinach-/vegetable tarts, Quiche Lorraine	---	---	40-60
Bread and bread rolls			
Brown bread	170-190*	3	45-60
White bread, loaf	170-190*	2	40-50
Flat bread, pita	---	---	15-25
Baked pasta dishes	180-200	1	
Potato gratin	180-200	2	
Cooking "au gratin"			
Hawaiian toast*	200-220	3	14-16

* Pre-heat the oven

Frozen Foods

Fan Oven 			
Type of pastry or cake	Temperature in °C	Shelf position	Baking time in minutes
Pizza (frozen)	Follow the manufacturer's instructions as stated on the package	Lay on the grill tray, insert baking tray below (shelf position in accordance with the manufacturer's instructions as stated on the package)	Follow the manufacturer's instructions as stated on the package

Also observe the manufacturer's instructions for all other frozen products.

Roasting

For roasting use the fan  oven function.

Ovenware for roasting

- Any heat-resistant dish is suitable for roasting (Refer to the manufacturer's instructions!).
- If the dish has plastic handles, check that they are heat-resistant (refer to manufacturer's instructions!).
- You can roast large roasting joints **directly in the universal tray or on the shelf with the universal tray inserted below** (e.g., turkey, goose, 3-4 chickens, 3-4 knuckles of veal).
- We recommend roasting all lean forms of meat **in a casserole dish with a lid** (e.g., veal, marinated beef, pot roast, frozen meat). In this way the meat will retain its juices.
- You can roast all forms of meat that are to be browned or crisped in a **casserole dish without a lid** (e.g., pork joints, meat loaf, lamb joints, mutton, duck, 1-2 knuckles of veal, 1-2 chickens, small poultry, sirloin, fillet, game).

 If you use dishes for roasting the oven will not get so dirty!

Notes on the roasting table

Information is given in the table on suitable oven functions, temperature settings, cooking times and shelf positions for various types of meat. The information is for guidance.

- We recommend roasting meat and fish **in the oven from a weight of 1kg**.
- To stop meat juices or fat burning onto dishes or the oven, we recommend adding a little water to the roasting dish.
- Turn the joint as required (after 1/2 - 2/3 of the cooking time).

 Baste large joints and poultry with meat juices several times during cooking. This will produce better roasting results.

 Switch the oven off approx. 10 minutes before the end of the roasting time to make use of the residual heat.

Roasting Table

Insert either the tray or universal tray into the 1st shelf support rail.

Fan Oven 				
Food to be roasted	Temperature in °C	Shelf position		Roasting time in minutes
		1 Level	2 Levels	
Pork				
1 kg Pork joint (spare rib/ham joint, roasting joint)	150-160	2	---	90-120
Smoked pork loin, 1-1,5kg	150-160	2	---	60-90
Meat loaf	160-170	2	---	60-70
Beef				
Beef joint, 1-1,5kg	150-160	2	---	120-150
Fillet of beef, per cm thickness	190-200*	2	---	6-8
Sirloin, per cm thickness	190-200*	2	---	8-10
Veal				
1 kg Veal joint	170-180	2	---	90-120
Lamb				
Leg of lamb (1800 g)	170-180	2	---	90
Poultry				
Roasting smaller items on the baking tray				
Sausages "cordon bleu"	220-230*	3	4+1	5-8
Sausages	220-230*	3	4+1	12-15
Escalope or chop coated with breadcrumbs	240-250*	3	4+1	13-15
Rissoles	210-220*	3	4+1	15-20

		Fan Oven 		
Food to be roasted	Temperature in °C	Shelf position		Roasting time in minutes
		1 Level	2 Levels	
Fish				
Trout weighing 200-250g	190-200	3	---	20-25
4 Trout fillets (weight 200g)	170-180	3	---	20-25
Perch fillet coated with breadcrumbs (total weight approx. 1 kg)	190-200	3	---	25-30
Poultry				
1 kg Turkey roast	150-160	2	---	90-120
Chicken	150-160	2	---	55-60
Duck (2000-2500 g)	150-160	2	---	90-120
Goose (4500 g)	150-160	2	---	150-180

* Pre-heat the oven

Grilling

To grill, use grill  oven function together with the appropriate temperature setting.



Important: Always close the oven door when grilling.



Always pre-heat the empty oven for 5 minutes using the **grill functions**.

Grilling implements

- When grilling, use an oven rack and a universal tray together.

Shelf position

- When grilling flatter foods, use mainly the 4th shelf level from the bottom.

Notes about the grilling tables

The grilling times are to be used as a guide only and depend on the type and quality of the fish and meat.

- Flatter cuts of meat and fish are especially well suited for grilling.
- Turn the items in the middle of the grilling period.

Grilling Table

Item	Temperature in °C	Universal tray	Grilling rack	Grilling time in minutes	
				Shelf position	1st side
4-8 pork chops	275	1	4	15	10
2-4 pork chops	275	1	4	12	12
marinated pork steaks	275	1	4	12	12
Fillet steak, rare	275	1	4	5-7	4-6
4 fillet steaks, medium	275	1	4	6-8	5-7
2 chicken halves	250	1	4	15-20	15-20
4 chicken halves	250	1	3	15-20	15-20
1-4 chicken thighs	250	1	4	20	10
4-6 chicken thighs	250	1	4	20	15
Grilling sausages,	275	1	4	5-10	5
Sausage coils	275	1	4	10	9
whole fish	250	1	3	10	---
Toast (without topping)	275	1	4	1-2	1-2

Defrosting

To defrost food, use the oven's defrosting function  without setting a temperature.

Defrosting dishes

- Put the food on a plate and put the plate on the tray.
- Use only parchment paper or film to cover the food. Do not use plates or dishes as they significantly increase the defrosting time.

Shelf levels

- Insert the shelf in the **1st position from the bottom** to defrost.

Notes on the defrosting table

The table below offers some guidance on defrosting times.

Defrosting table

Dish	Defrosting time Mins.	Standing time Mins.	Note
Chicken, 1000 g	100-140	20-30	Place the chicken on an upside-down saucer on a large plate. Defrost open and turn after half the time, or defrost covered with film.
Meat, 1000 g	100-140	20-30	Defrost open and turn after half the time or cover with film.
Meat, 500 g	90-120	20-30	Defrost open and turn after half the time or cover with film.
Trout, 150 g	25-35	10-15	Defrost open.
Strawberries, 300 g	30-40	10-20	Defrost open.
Butter, 250 g	30-40	10-15	Defrost open.
Cream, 2 x 200 g	80-100	10-15	Defrost open (Cream can also be whipped well if parts of it are still slightly frozen).
Flan, 1400 g	60	60	Defrost open.

Drying with the Fan Oven

Use trays lined with greaseproof paper or baking paper.

You will achieve a better result if you switch the oven off half way through the drying time.

Open and leave to cool, preferably overnight. Then finish drying the dried food.

	Temperature in °C	Time in hours (approximate guide)
Vegetables		
Beans	60-70	6-8
Peppers (strips)	60-70	5-6
Vegetables for making soup	60-70	5-6
Mushrooms	50-60	6-8
Herbs	40-50	2-3
Fruit		
Plums	60-70	8-10
Apricots	60-70	8-10
Sliced apple	60-70	6-8
Pears	60-70	6-9

Cleaning and care



Warning: For safety reasons cleaning the appliance with a steam jet cleaner or high-pressure water cleaner is **not permissible!**

Exterior of the Appliance

- Wipe the front of the appliance with a soft cloth dipped in warm soapy water.
- Do not use scourers, caustic cleaners or abrasive items.
- Use commercially available cleaners for metal fronts.

Oven Interior



Warning: The oven must be switched off and cold before cleaning.

Clean the appliance after each use. This is the easiest way to remove spills and prevents them being burnt on.

1. Switch on the oven lighting when cleaning.
2. Every time you use the oven, wipe it out afterwards with water and washing-up liquid, then dry. Do not use any abrasive items.
3. Remove stubborn marks with special oven cleaners.



Important: Always follow the manufacturer's instructions when using oven spray!

Accessories

Wash all slide-in units (shelf unit, baking tray, shelf support rails etc.) after each use and dry well. Soak briefly to make them easier to clean.

Shelf Support Rails

The shelf support rails on the left and right hand sides of the oven can be removed for cleaning the side walls.

Removing the shelf support rails

First pull the front of the rail away from the oven wall (1) and then unhook at the back (2).

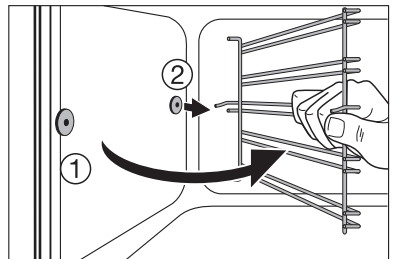
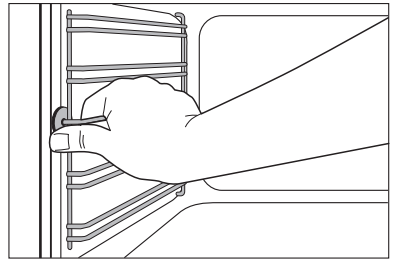

Fitting the shelf support rails

i **Important!** The rounded ends of the guide rails must be pointing forwards!

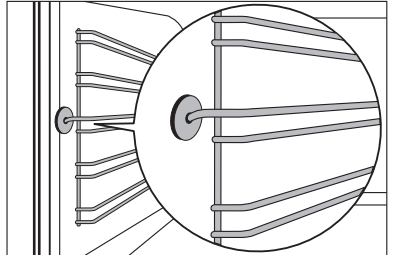

To re-insert, first hook the rail into place at the back (1) and then insert the front and press into place (2).

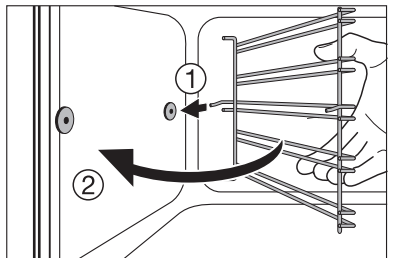

Oven Lighting



Warning: Risk of electric shock! Prior to changing the oven light bulb:

- Switch off the oven!
- Disconnect from the electricity supply.



Place a cloth on the oven floor to protect the oven light and glass cover.

Changing the oven light bulb/cleaning the glass cover

1. Remove the glass cover by turning it anti-clockwise and then clean it.
2. If necessary: replace with **25 watt, 230 V, 300 °C heat-resistant oven lighting.**
3. Refit the glass cover.

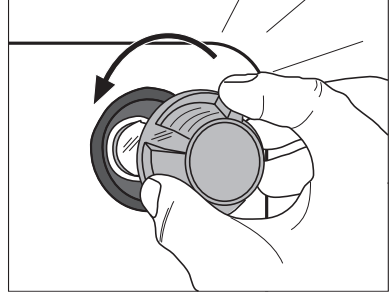

Oven Roof

The upper heating element can be folded down to make it easier to clean the oven roof.

Folding down the heating element



Warning: Only fold down the heating element when the oven is switched off and there is no risk of being burnt!

1. Remove the side shelf support rails.
2. Grip the heating element at the front and pull it forwards and out over the support lug on the inner wall of the oven.
3. The heating element will now fold down.



Caution: Do not use force to press the heating element down! The heating element might break.

Clean the oven roof

Repositioning the heating element

1. Move the heating element back up towards the oven roof.
2. Pull the heating element forwards against the spring pressure and guide it over the oven support lug.
3. Settle it onto the support.
4. Insert shelf support rail.



Important: The heating element must be positioned correctly and securely on both sides above the support lug on the inner wall of the oven (2).

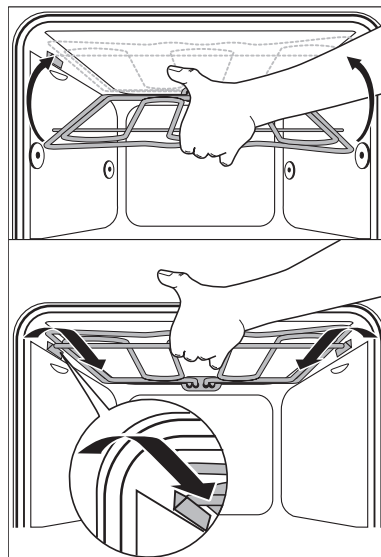
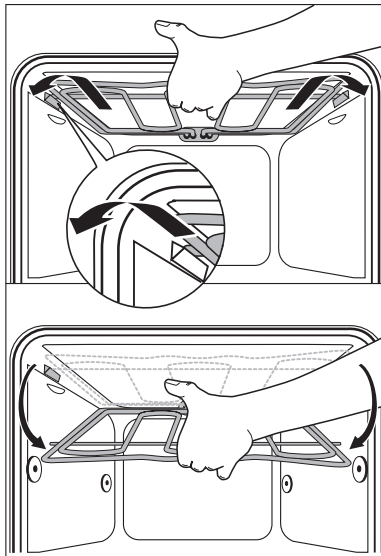

Oven Door

The oven door of your appliance may be removed for cleaning.

Removing the oven door

1. Open the oven door completely.
2. **Completely** fold back the **brass-coloured clamping lever** on **both** door hinges.
3. Grip the oven door with both hands on the sides and close it to about 3/4 **going past the point of resistance**.
4. Pull the door away from the oven (**Caution:** heavy!).
5. Place the door, with the outer surface downwards, on a soft, flat surface, for example a blanket, to avoid scratches.

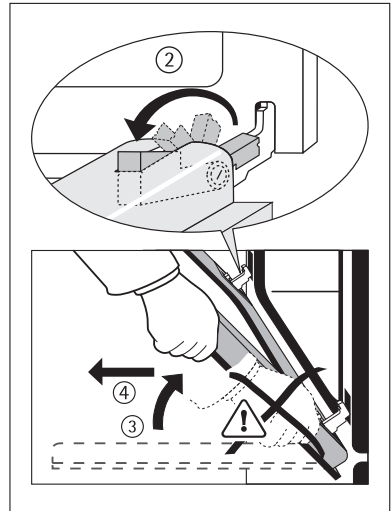

Hanging the oven door

1. With both hands take hold of the sides of the door from the side on which the handle is positioned.
2. Hold the door at an angle of approx. 60°.
3. Slide the door hinges **simultaneously** as far as possible into the two slots on the right and left at the bottom of the oven.
4. Lift the door up until resistance is met and then open fully.
5. Lift the brass-coloured clamping levers on both door hinges back to their original position.
6. Close the oven door.

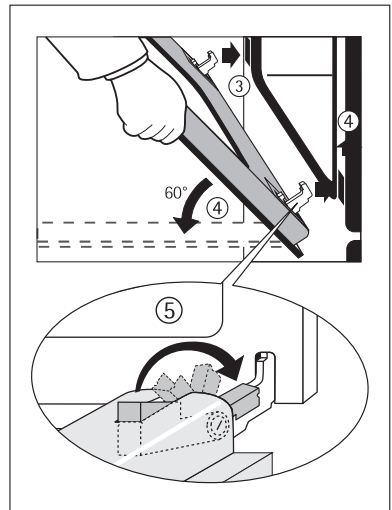

Oven Door Glass

The oven door is fitted with two glass panels mounted one behind the other. The inner panel can be removed for cleaning.



Caution: the following steps must be performed only with the oven door removed! If the glass is removed while the door is attached, the lighter weight may cause it to spring up and cause injury.



Important! Rough handling of the glass, especially at the edges of the front panel, may cause it to break.

Removing the glass from the door

1. Detach the door and, with the handle downwards, place it on a soft, even surface.
2. Grasp the top glass panel underneath, and push it towards the door handle against the pressure spring, until it comes free.
3. Hold the panel **gently** underneath, and slide it out.

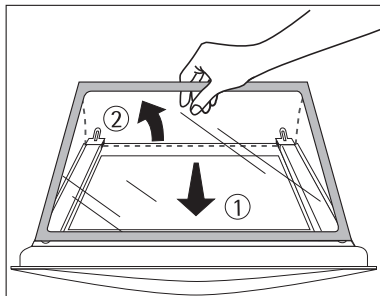

Clean the glass panel

Inserting the glass to the door

1. Insert the panel at an angle from above into the section of the door in which the handle is located.
2. Lower the panel. Place the glass against the pressure spring at the handle end, and in front of the retaining frame at the bottom of the door, then push it **into the frame**.
The glass panel must be firmly attached!

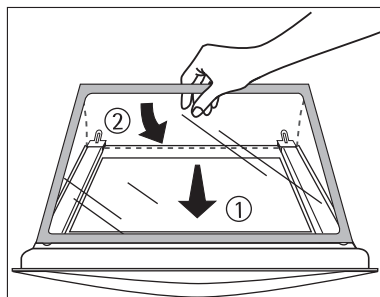

Re-hang the door to the oven.

What to do if ...

Fault	Possible cause	Remedy
The oven does not heat.	The oven has not been switched on.	Switch the oven on.
	The required settings have not been made.	Check the settings.
	The domestic electrical protection device (fuse) has been tripped.	Check the fuses or protection devices. If these are tripped repeatedly, you should call a qualified electrician.
The oven light does not come on.	The bulb has blown.	Replace the bulb (see Care and Cleaning).

If you are unable to remedy the fault with the above assistance, please contact your specialist dealer or Service Force Centre.



Warning: Repairs to the appliance may only be carried out by approved service engineers. Repairs carried out by inexperienced persons may cause serious injury to the user. If the appliance has been used incorrectly, the customer service engineer's visit or that of the specialist dealer will not be free of charge, even during the warranty period.



Advice on cookers with metal fronts:

Because of the cold surface at the front of the cooker, opening the oven door during (or just after) baking or roasting may cause the glass to steam up.

Technical Data

Oven Interior Dimensions

Height x Width x Depth
Capacity (usable capacity)

31 cm x 41 cm x 41 cm
52 l

Regulations, Standards, Directives

This appliance meets the following standards:

- EN 60 335-1 and EN 60 335-2-6
relating to the safety of electrical appliances for household use and similar purposes and
- EN 60350, or DIN 44546 / 44547 / 44548
relating to the operating features of electric cookers, hobs, ovens, and grills for household use.
- EN 55014-2
- EN 55014
- EN 61000-3-2
- EN 61000-3-3
relating to basic requirements for electro-magnetic compatibility protection (EMC)

 This appliance complies with the following EU Directives:

- 73/23/EWG dated 19.02.1973 (Low Voltage Directive)
- 89/336/EWG dated 03.05.1989 (EMC Directive including Amending Directive 92/31/EWG).

Installation Instructions



Important: The new appliance may only be installed and connected by a **qualified electrician / competent person**.



Please observe this instruction, otherwise the warranty will not cover any damage that may occur.

Safety Instructions for the Installer

- A device must be provided in the electrical installation which allows the appliance to be disconnected from the mains at all poles with a contact opening width of at least 3 mm.
Suitable isolation devices are, for example, circuit breakers, fuses (screw-type fuses are to be removed from the holder), earth leakage trips and contactors.
- The installation must guarantee shock protection.
- The stability of the unit in which the appliance is fitted must satisfy the requirements of DIN 68930.
- Built-in ovens and hobs are fitted with special connector systems. They may only be combined with appliances with a matching system.

Electrical Connection

The oven is designed to be connected to 230-240V~(50Hz) electricity supply.

The oven has an easily accessible terminal block which is marked as follows:

- Letter L - Live terminal
- Letter N - Neutral terminal
-  - Earth terminal



This oven must be earthed!

The cable used to connect the oven to the electrical supply must comply to the specifications given below.

For UK use only

Connection via	Min. size Cable/flex	Cable/flex type	Fuse
<ul style="list-style-type: none">• 13 A socket outlet• 13 A spur box	2,5 mm ²	3 core butyl insulated	13 A min.
<ul style="list-style-type: none">• Cooker Control Circuit	2,5 mm ²	PVC/PVC twin and earth	15 A min. 20 A max.

It is necessary that you install a double pole switch between the oven and the electricity supply (mains), with a minimum gap of 3mm between the switch contacts and of a type suitable for the required load in compliance with the current regulations.

The switch must not break the yellow and green earth cable at any point.

Important

After installation and connecting, the cable must be placed so that it cannot at any point reach a temperature of more than 50°C above the ambient temperature.

Before the oven is connected, check that the main fuse and the domestic installation can support the load; and that the power supply is properly earthed.

The manufacturer declines any responsibility should these safety measures not be carried out.

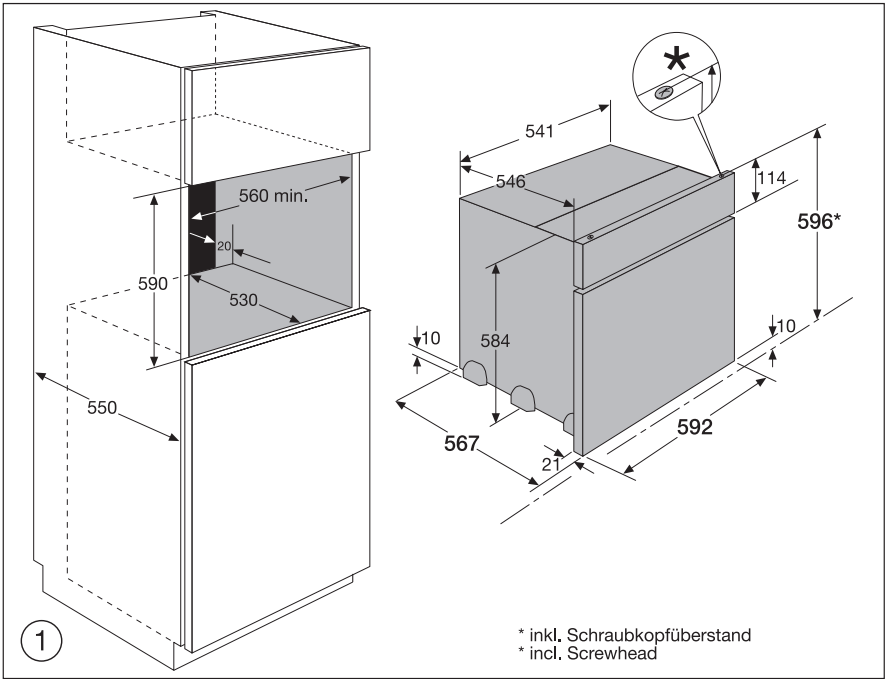

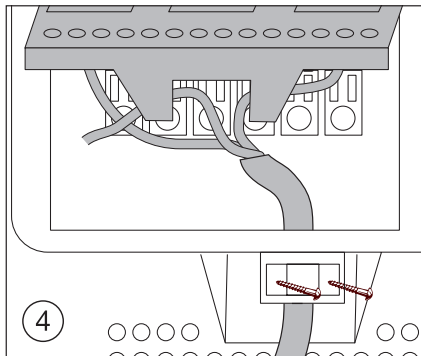
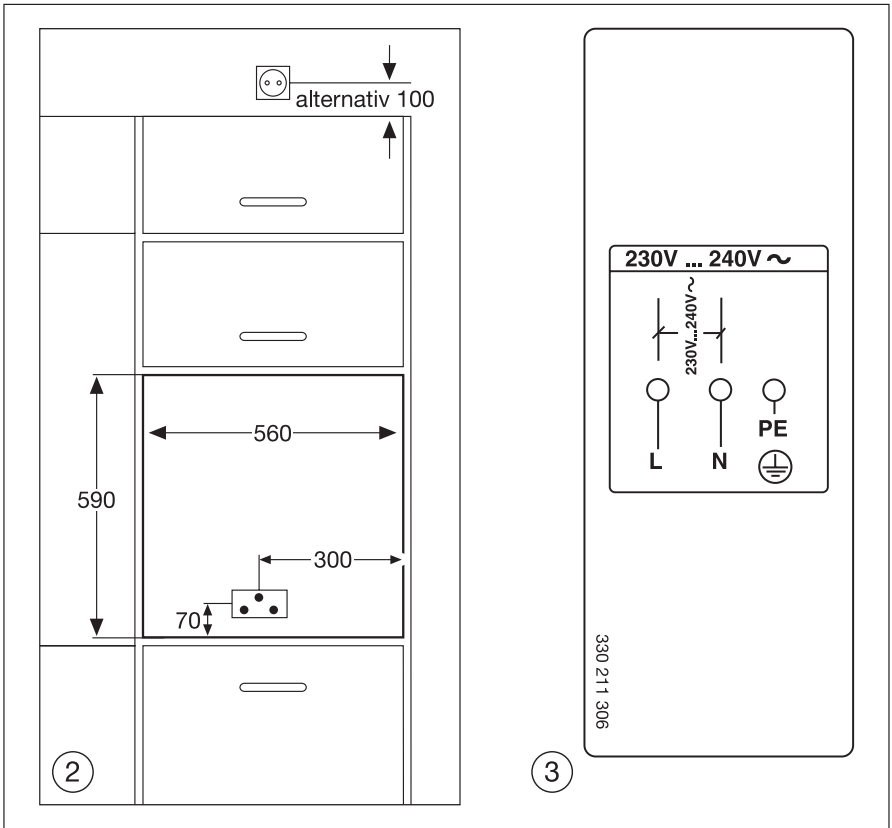

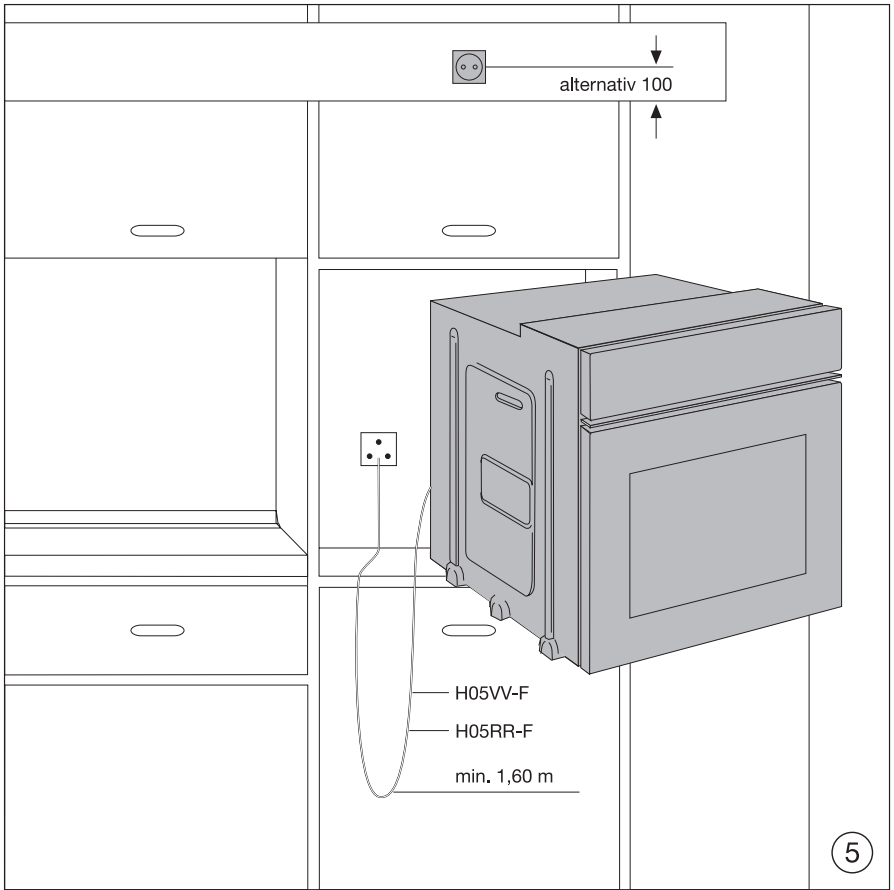

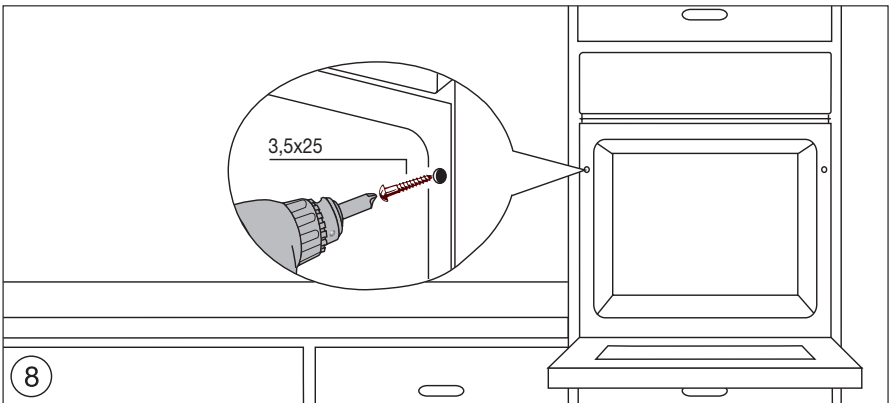
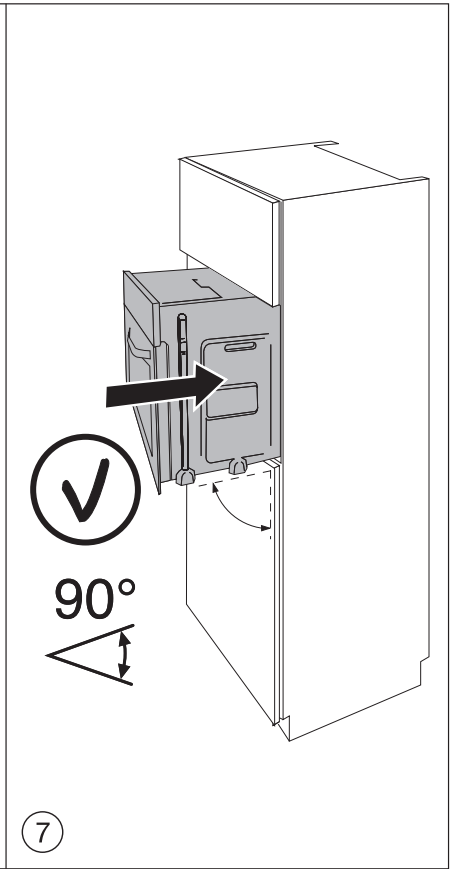
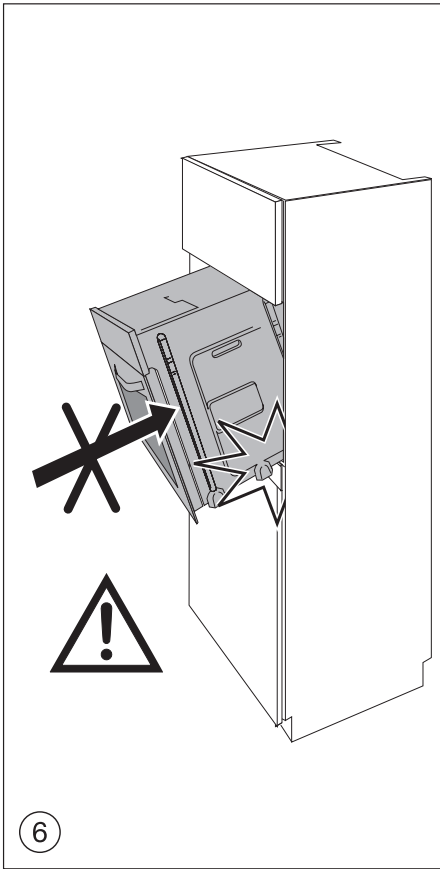

Guarantee Conditions

Standard guarantee conditions

We, Electrolux, undertake that if within 12 months of the date of the purchase this Electrolux appliance or any part thereof is proved to be defective by reason only of faulty workmanship or materials, we will, at our option repair or replace the same FREE OF CHARGE for labour, materials or carriage on condition that:

- The appliance has been correctly installed and used only on the electricity supply stated on the rating plate.
- The appliance has been used for normal domestic purposes only, and in accordance with the manufacturer's instructions.
- The appliance has not been serviced, maintained, repaired, taken apart or tampered with by any person not authorised by us.
- All service work under this guarantee must be undertaken by a Service Force Centre.
- Any appliance or defective part replaced shall become the Company's property.
- This guarantee is in addition to your statutory and other legal rights.

Home visits are made between 8.30am and 5.30pm Monday to Friday. Visits may be available outside these hours in which case a premium will be charged.

Exclusions

This guarantee does not cover:

- Damage or calls resulting from transportation, improper use or neglect, the replacement of any light bulbs or removable parts of glass or plastic.
- Costs incurred for calls to put right an appliance which is improperly installed or calls to appliances outside the United Kingdom.
- Appliances found to be in use within a commercial environment, plus those which are subject to rental agreements.
- Products of Electrolux manufacture which are not marketed by Electrolux.

European Guarantee

If you should move to another country within Europe then your guarantee moves with you to your new home subject to the following qualifications:

- The guarantee starts from the date you first purchased your product.
- The guarantee is for the same period and to the same extent for labour and parts as exists in the new country of use for this brand or range of products.
- This guarantee relates to you and cannot be transferred to another user.
- Your new home is within the European Community (EC) or European Free Trade Area.
- The product is installed and used in accordance with our instructions and is only used domestically, i.e. a normal household.
- The product is installed taking into account regulations in your new country.

Before you move please contact your nearest Customer Care centre, listed below, to give them details of your new home. They will then ensure that the local Service Organisation is aware of your move and able to look after you and your appliances.

France	Senlis	+33 (0) 3 44 62 20 13
Germany	Nürnberg	+49 (0) 800 234 7378
Italy	Pordernone	+39 (0) 800 11 7511
Sweden	Stockholm	+46 (0) 20 78 77 50
UK	Slough	+44 (0) 1753 219898

Index

A

Accessories 9

C

Cleaning

accessories 27
initial cleaning 10
Oven Ceiling 30
Oven door glass 32
Oven light bulb 29
shelf support rails 28
Combination shelf 9
Control panel 8

D

Defrost 12
Defrosting 25
Description of the appliance 7
Disposal 6

G

Grill pan 9
Grill tray 9

O

Oven

accessories 9
functions 12
light bulb 29
operating 11

R

Repairs 5

S

Safety 5
Shelf support rails 28

T

Tables and tips 15

W

What to do if 33

Service and Spare Parts

If you wish to purchase spare parts or require an engineer, contact your local Electrolux Service Force Centre by telephoning:

08705 929 929

Your telephone call will be automatically routed to the Service Force Centre covering your post code area.

For the address of your local Service Force Centre and further information about Service Force, please visit the website at

www.serviceforce.co.uk

When you contact the Service Centre they will need the following information:

1. Your name & address, including post code.
2. Your telephone number
3. Clear and concise details of the fault.
4. The model and serial number of the appliance (found on the rating plate).
5. The purchase date:

Please note that a valid purchase receipt or guarantee documentation is required for in-guarantee service calls.

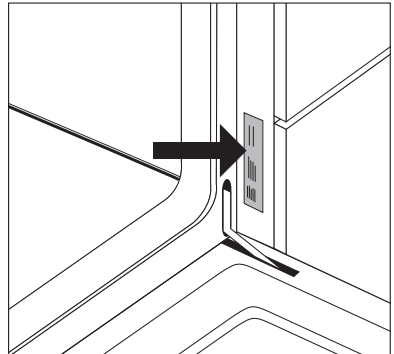

Customer Care

For general enquiries concerning your Electrolux appliance or for further information on Electrolux products please contact our Customer Care Department by letter or telephone at the address below or visit our website at

www.electrolux.co.uk.

Customer Care Department

Electrolux

55-77 High Street

Slough

Berkshire, SL1 1DZ

Tel. 08705 950950 (*)

(*) Calls may be recorded for training purposes.

822 923 229-A-030203-05

© **Electrolux plc 2002**
Subject to change without notice

 **The Electrolux Group. The world's No.1 choice.**

The Electrolux Group is the world's largest producer of powered appliances for kitchen, cleaning and outdoor use. More than 55 million Electrolux Group products (such as refrigerators, cookers, washing machines, vacuum cleaners, chain saws and lawn mowers) are sold each year to a value of approx. USD 14 billion in more than 150 countries around the world.