

# Installation Instructions

452W

SIZE 90  
Series E

GAS-FIRED AIR CONDITIONER

bryant

FILE  
COPY  
DO NOT  
REMOVE

Supersedes: 39452D70

39452D80  
2/15/73

## Important—Read before Installing

1. Check all local or other applicable codes for information concerning proximity to property lines, height above roof, obstructions, etc.
2. Be sure the power supply available (voltage, frequency, and phase) corresponds to that specified on the unit rating plate.
3. Check the electrical service provided by the utility for the building to be sure that the service capacity is sufficient to handle the load imposed by this unit.
4. Refer to the regulations of the serving gas supplier and the local building, heating, plumbing, or other codes in effect in the area in which installation is to be made.
5. Refer to the dimensional drawing on page 2 for location of electrical, gas, and chilled-water connections prior to setting the unit in place.



B71090

Figure 1 - Model 90-452W Gas Air Chiller

## GENERAL

Model 90-452W is a gas-fired air-cooled absorption unit designed to satisfy the cooling needs of commercial and industrial buildings. This absorption unit supplies chilled water for cooling with Bryant's indoor and outdoor coil assemblies.

### Multiple Chillers and Cooling Coils

When it is planned to connect two or more chillers or coils, additional piping and electrical information is required and should be obtained from your Bryant Distributor. When making multiple chiller installations, it is recommended that only Models 452 and 452W be interconnected. Interconnection of sizes 60, 90, and 120 is permissible, but the use of other model chillers with Models 452 and 452W in a multiple system should be avoided.

### Operation at Atmospheric Pressure

The chilled-water tank on this unit is vented to the atmosphere; consequently, the chilled-water circuit operates at atmospheric pressure. Therefore, conventional piping practices for a closed, pressurized system do not apply for this unit.

**NOTE:** When the water chiller is piped to a boiler as described below, the indoor coil operates at or near atmospheric pressure when used for cooling; the indoor coil may be pressurized when it is used with the boiler for heating.

When this chiller is piped with a boiler to form a combination heating and cooling system, provisions must be made for a positive shutoff between the chiller tank and the boiler.

When the boiler is in operation, the chiller tank must be bypassed. A sediment strainer must be installed at the chiller tank inlet when a common pipe connects the chiller tank and boiler.

When the chiller is in operation the boiler, of course, should be bypassed.

## Installation

Installation of the Model 90-452W, Series E Gas Chiller unit consists of the following steps:

- I. Locating and Mounting the Unit
- II. Connecting Chilled-Water Lines
- III. Making Electrical Connections
- IV. Making Gas Connections
- V. Chilled-Water System
- VI. Checking the Unit Operation
- VII. Adjusting Gas Input
- VIII. Balancing the System

Each of the above steps is discussed in detail in this instruction. *Read the entire instruction before starting the installation.*

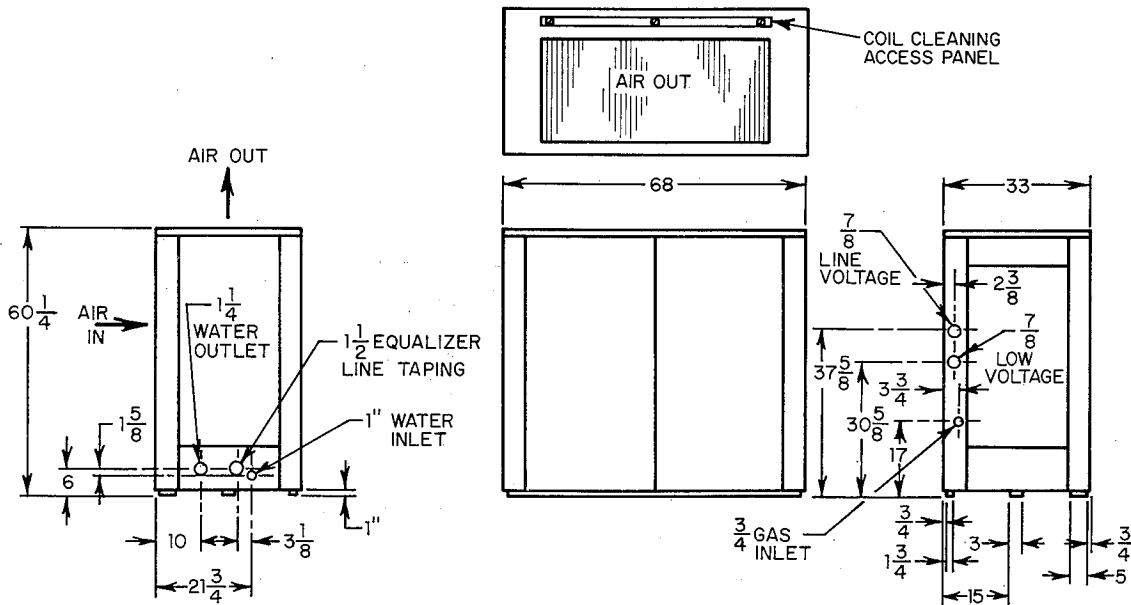

Figure 2 - Dimensional Drawing

A69102

### RATINGS AND PERFORMANCE

MODEL	90-452W Series E	
	200-60-1	230-60-1
Unit Rating Plate (Voltage-Hertz-Phase)	200-60-1	230-60-1
Cooling Capacity	Btuh 90,000	90,000
Gas Input	Btuh 246,000	246,000
Condenser Air Delivery	CFM 10,000	10,000
Chilled-Water Flow Rate (Nominal)	GPM 18.75	18.75
Max Head at Nominal Water Flow	Ft Water 37	37
Electrical Input	KW 2.5	2.5
Fan Motor (2)	HP & SF 1/2 & 1.0	1/2 & 1.0
Voltage Hertz-Phase	200/230-60-1	200/230-60-1
Capacitor (370 Volts)	mfd 10	7.5
Hydraulic Pump Motor	HP & SF 1 & 1.25	1-1/2 & 1.25
Voltage-Hertz-Phase	200-60-1	208/230-60-1
Alternate Hydraulic Pump Motor	HP & SF 1 & 1.25	1 & 1.25
Voltage-Hertz-Phase	200-60-1	230-60-1
Chilled-Water Pump	HP & SF 1/3 & 1.35	1/3 & 1.35
Voltage-Hertz-Phase	200-230-60-1	200-230-60-1
Refrigerant	Type R717	R717
Amount	Lbs 18	18
Total Solution	Lbs 55	55
Bryant Sound Rating	SRN 22	22
Approximate Shipping Weight	Lbs 1317	1317

### CONNECTIONS

MODEL	90-452W Series E	
	200-60-1	230-60-1
Unit Rating Plate (Voltage-Hertz-Phase)	200-60-1	230-60-1
Unit Ampacity for Electrical Conductor Sizing	Amps 19.25	26.2
*Min Branch Circuit Wire Size	AWG No. 12	10
Recommended Fuse Size	Amps 35	35
**Maximum Line Length	Ft 71	115
Control Circuit	Volts 24	24
External Power Available	VA 5	5
Gas Supply Connection Size	Inches 3/4 NPT	3/4 NPT
Chilled-Water Supply (NPT)	Inches 1-1/4FPT	1-1/4FPT
Chilled-Water Return (NPT)	Inches 1 FPT	1 FPT
Equalizer Line (NPT)	Inches 1-1/2FPT	1-1/2FPT

\*If other than 75°C copper conductor is used, determine size from unit ampacity and the National Electric Code. Voltage drop of wire selected must be less than 2% of unit rated voltage.

\*\*Length shown is for one way along the wire path from unit to service panel.

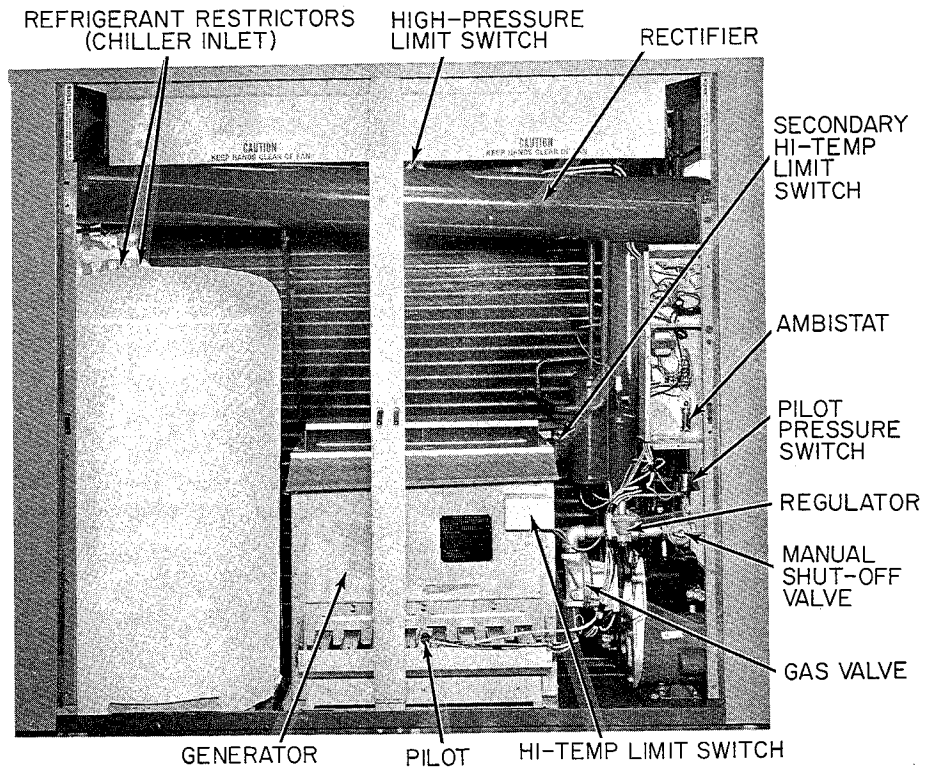

A72597

**Figure 3 - Unit Front View With Access Panels Removed**

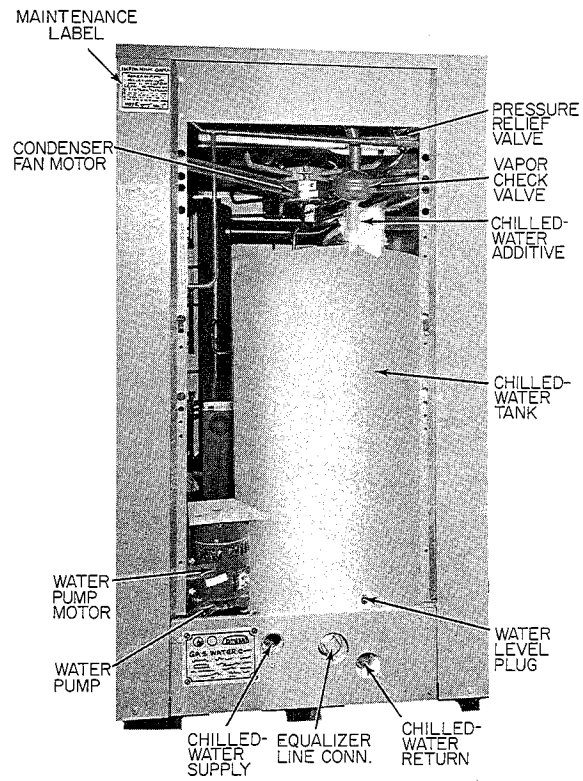

B71051

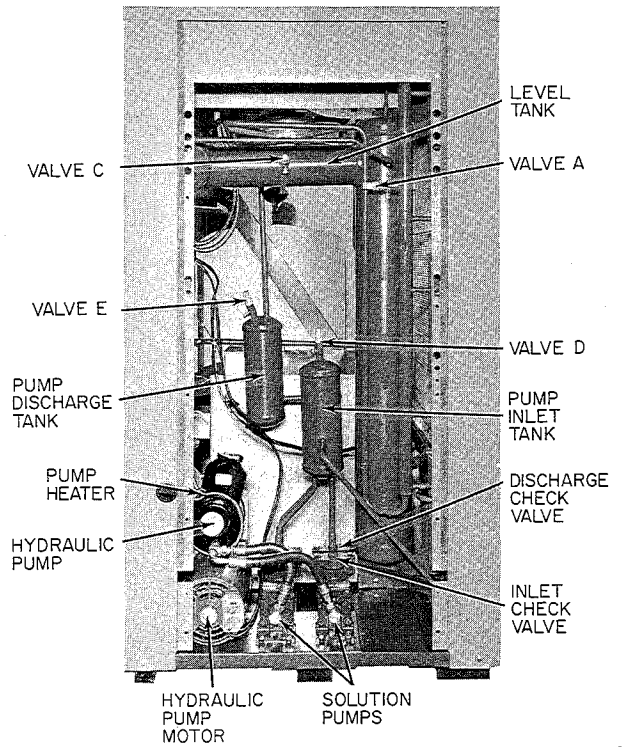

A72596

**Figure 4 - Unit Left-Side View With Access Panel Removed**

**Figure 5 - Unit Right-Side View With Access Panel Removed**

## I. LOCATING AND MOUNTING UNIT

The absorption unit is approved for outdoor installation only and may be located at ground level or on the roof. Consult local or other applicable codes for information concerning proximity to property lines, height above roof, obstructions, etc.

### A. Mounting Base

1. USE NONCOMBUSTIBLE MATERIALS.
2. Suggested types of mounting base for ground installation:
  - a. Precast concrete lintels. Use three lintels the depth of unit, one each under right and left end of unit, and one at center of unit.
  - b. Concrete blocks. Use one block at each corner of unit plus blocks under the two long sides midway between the corner blocks.
  - c. Concrete slab. Minimum thickness 4 inches.

3. Leave sufficient clearance (6 inches minimum) between unit base and roof for proper air circulation when installing unit on a roof. Use precast concrete lintels or concrete blocks as described in paragraph 2, or use steel beams. Check local codes. Refer to NBFU code for Installation of Heat Producing Appliances.

### B. Clearances

1. Absorption unit should have a minimum clearance of 2 feet on all sides from any adjacent obstruction.
2. Avoid locating the unit where hot condenser air can impinge on nearby obstructions and mix with the inlet air supply. The condenser air discharges upward. The unit should be located outside of the plumb line from any overhang when the distance from the overhang to the top of the unit is less than 7 feet.

## II. CONNECTING CHILLED-WATER LINES

Refer to "Multiple Chillers and Cooling Coils," page 1; "Operation at Atmospheric Pressure," page 1; and "Chilled-Water System", page 7, before making any chilled-water connections.

TABLE I

Nominal Pipe Size (Inches)	*Allowable Distance Between Coil & Chiller		
	Polyethylene Pipe (Feet)	Copper Pipe (Feet)	Galvanized Pipe (Feet)
1	30	51	54
1-1/4	205	165	220
1-1/2	490	388	492

NOTE: Values shown in Table I are for one direction only. The total length of pipe from chiller to coil and return would be double the values given. The above table applies to single unit installations only.

### A. Materials

NOTE: Black iron pipe must not be used for chilled-water piping.

1. Piping
  - a. Polyethylene Plastic Pipe - use medium density flexible pipe whose wall thickness approximates Schedule 40 pipe (Commercial Standard CS 255-63). Pipe must be virgin plastic. Do not use pipe manufactured from reclaimed plastic.
  - b. Copper—satisfactory substitute.
  - c. Galvanized—satisfactory substitute.
2. Fittings
  - a. Galvanized—use when possible.
  - b. Brass—satisfactory substitute.
  - c. Nylon—satisfactory substitute.

### B. Pipe Length and Diameter

Table I shows maximum length of pipe of different diameters that can be used between the pump discharge and the coil inlet and still maintain minimum allowable (design) water flow rate.

1. Multiply table values by two to obtain total length of pipe from chiller to coil and return.
2. Length is measured along pipe path and therefore includes vertical distance between water coil and chiller.
3. Lengths shown in Table I are based on using a total of eight galvanized wellhead elbows in entire water line (chiller to coil and return). Lengths are predicated on use of a Bryant matching water coil. For greater distances, use larger pipe or add a pump. Consult your Bryant Distributor for additional information.

### C. Insulation

1. Insulate supply and return lines separately.
2. Material should be of good quality and be covered with a good vapor barrier. Armaflex or equivalent is recommended.

Wall thickness: 1/2 inch.

### D. Height of Coil above Absorption Unit

Practical coil elevation is limited only by the atmospheric pressure supported hydraulic head.

### E. Water Coil Connections

1. If cooling coil is used in connection with heating unit, and heating unit is not approved for installation downstream from cooling coil, install cooling coil in parallel with, or downstream of, heating unit. This will avoid condensation in heating unit. If coil and heating unit are installed in parallel, dampers or other means used to control flow of air should be adequate to prevent chilled air from entering heating unit, and if manually operated, shall be equipped with means to prevent operating of either unit unless dampers are in full heat or cool positions.
2. If coil is located in warm air stream, do not connect polyethylene pipe directly to coil. Connect minimum of 24 inches of copper or galvanized pipe to both coil inlet and outlet. Then connect plastic pipe to these nipples.
3. Precautions must be taken to provide for water expansion on installations where outside piping is subject to freezing temperatures and coil is in a heated air stream. The connecting polyethylene plastic pipe acts as an expansion vessel if there is enough footage of this pipe in heated space (space not subject to freezing temperatures). Table II shows minimum lengths (total inlet and outlet) of plastic piping of various diameters required to provide adequate expansion volume.

If total plastic chilled-water line footage in heated space is not as long as minimum value shown in Table II, tee off additional length of polyethylene pipe to either side of coil to meet required footage. Cap open end of added polyethylene pipe.

**TABLE II**

Nominal Pipe Size (Inches)	Length of Plastic Pipe (Feet)
1	60
1-1/4	35
1-1/2	25

### III. MAKING ELECTRICAL CONNECTIONS

1. Make all electrical connections in accordance with the National Electrical Code and any local ordinances or codes that might apply.
2. The unit must be electrically grounded in accordance with the National Electrical Code, ANSI C1 dated 1968 when installed.
3. Provide separate power supply for air conditioner.
4. Provide fused disconnect switch within sight of, and not more than 50 feet from, absorption unit. Use 35-amp standard fuse or 25-amp fusetron.
5. Unit is shipped from the factory completely wired. Connection of the power supply to power relay is made directly into control box through knockout in corner panel on right side of unit.

Low-voltage (24-V) wires from thermostat control enter directly into control box through knockout in panel on right side. Low-voltage wires are connected at terminal block. See Figure 6 for location of control box components.

6. Figure 9 is a line-to-line wiring diagram of unit.
7. Disconnect chilled-water pump electrical leads at power relay in control box before energizing unit when ready to check field wiring. *Do not operate pump dry.*

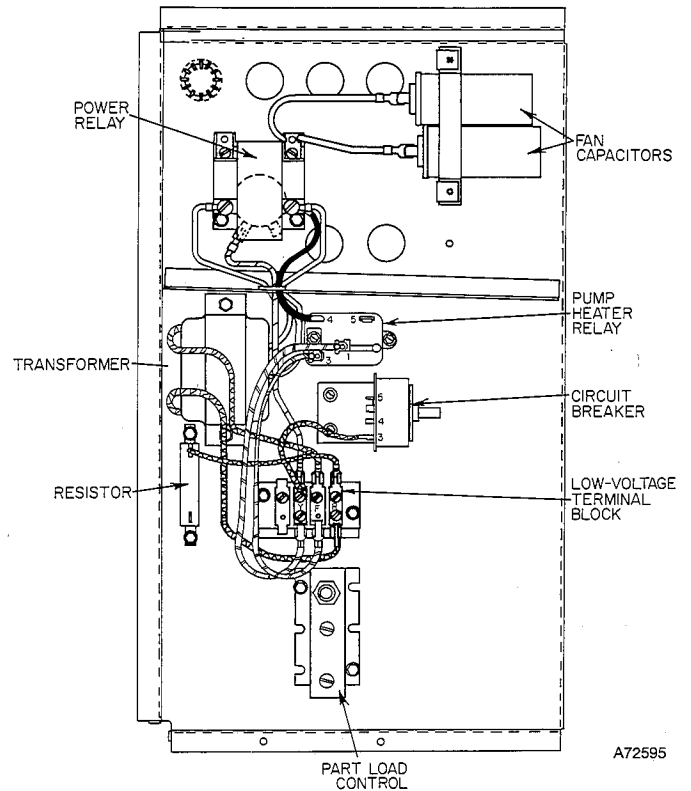

**Figure 6 - Control Box Components**

### IV. MAKING GAS CONNECTIONS

Consult local gas company before making any gas connections. In case of conflict with this instruction, local requirements should be followed. This appliance is not suitable for use with conventional venting systems.

Refer to the American National Standard for Installation of Gas Appliances and Gas Piping Z21.30 dated 1964, in the absence of local building codes.

Before selecting the size and type of pipe that is to be used for installing the absorption unit, be sure to check with local gas company for the necessary information. The size of the gas pipe to be used between meter and unit will depend upon the length of run and the allowable pressure loss established by the utility.

The gas connection to the unit is made to the 3/4-inch shutoff valve at the control manifold. The supply pipe enters the unit through an opening in the corner panel

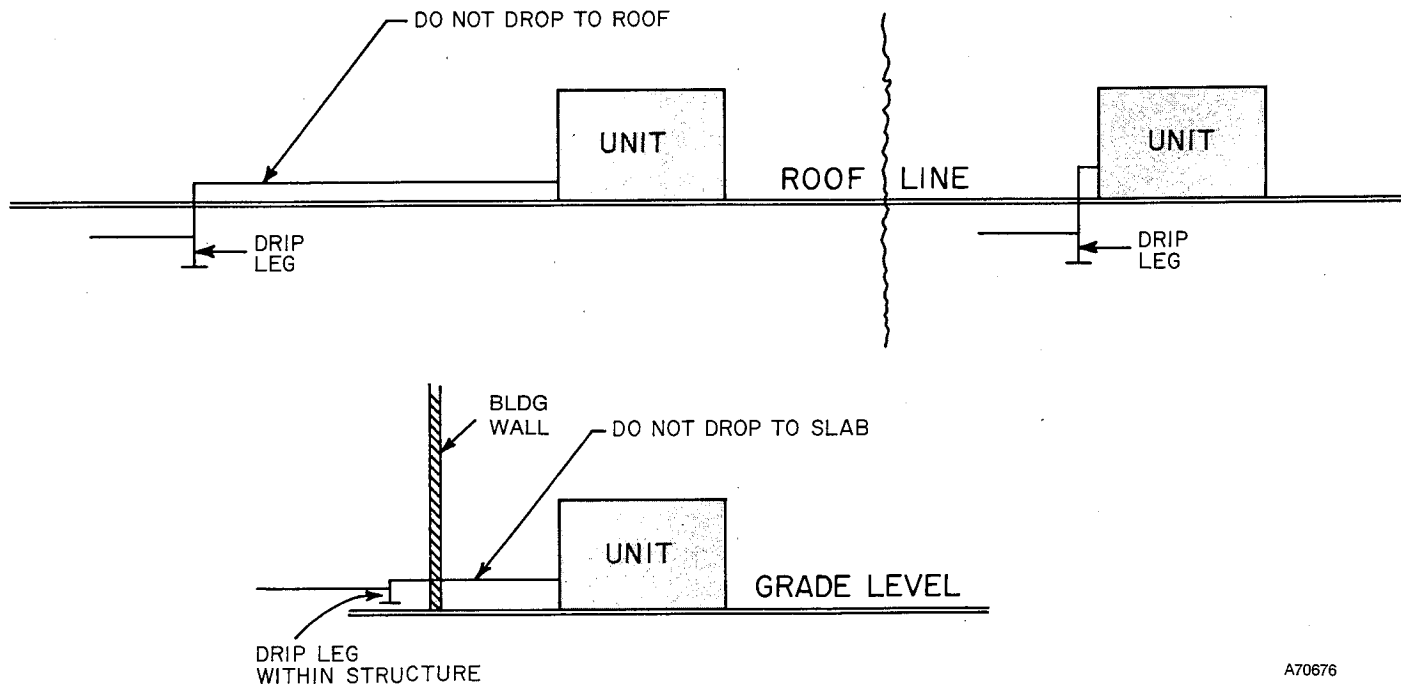

A70676

Figure 7 - Drip Leg Location

on the right side. Install a drip leg trap in the gas supply riser leading to the unit.

The following are pertinent recommendations:

1. Avoid low spots in long runs of horizontal pipe. It is best to grade all pipe 1/4 inch for every 15 feet to prevent traps. All horizontal runs should grade downward to risers. Use risers to connect to unit and to meter.
2. Install drip leg in riser leading to unit. Drip leg will serve as trap for dirt and condensate. Install drip legs where condensate will not freeze. See Figure 7 for drip leg location.
3. Install wrench-type shutoff valve in gas supply line within sight of, and convenient to, unit.
4. Place ground joint union close to unit between gas controls manifold and wrench-type shutoff valve.
5. Support all piping with appropriate hangers. Maximum distance between hangers should be 10 feet.
6. Joint compound (pipe dope) which is resistant to action of liquefied petroleum gases should be applied sparingly and only to male threads of joints.
7. After all gas pipe connections are made, purge lines and check for leakage. Turn off power supply to unit when purging lines to prevent glow coil in reignition pilot from being energized. Use a soap-and-water solution for leak-checking.

**WARNING:** Never use matches, candles, or other sources of ignition to check for gas leakage.

#### Pilot

Both natural gas and propane gas units are equipped with an automatic reignition pilot. The pilot will light automatically when supplied with gas and is electrically energized.

Light the pilot using the procedure outlined on the lighting instruction plate attached to the generator. However, when lighting the pilot for the first time, perform the following additional steps:

1. If supply line was not purged prior to connecting unit, it will be full of air. Because venting air through small pilot port is a lengthy process, it is recommended that pilot supply line be disconnected at pilot shutoff valve and supply line be allowed to purge until odor of gas is detected.

**WARNING:** Never purge gas lines into the combustion chamber.

Immediately upon detection of gas odor, reconnect pilot supply tube. Allow 5 minutes to elapse and light pilot in accordance with instructions on lighting plate.

2. Pilot flame should be soft blue in color and of sufficient length to provide good impingement on unimetal of Bryant pilot. Flame should extend upward between carryover ports of two adjacent burners.
3. If pilot flame does not have appearance described above, adjust it by means of manual pilot shutoff valve.
  - a. The valve is equipped with an adjustable screw. Turn handle to full open position, and

remove screw cap to expose adjustable screw. Turn adjusting screw until flame has desired appearance.

b. Replace screw cap.

## V. CHILLED-WATER SYSTEM

**CAUTION:** Do not run the pump dry. Freezing conditions will not damage the pump; however, do not attempt to operate the pump when chiller or chilled-water lines are frozen.

### Corrosion Protection

The components of the chilled-water circuit must be protected from corrosion by the addition of an inhibitor to the chilled-water system. Chilled-Water Additive P/N 62875D1 must be added when water only, or when water and methanol antifreeze, are used in the chilled-water system.

The package of Chilled-Water Additive P/N 62875D1 supplied with the unit is sufficient for systems containing up to 15 gallons. For systems larger than 15 gallons, add one package for each additional 15-gallon capacity or fraction thereof. To estimate the capacity of the chilled-water system, refer to Table III.

**TABLE III**  
Water Capacity in Gallons

90-452W Chiller	9.7
Bryant 18,000-Btuh Coil	0.6
Bryant 36,000-Btuh Coil	1.0
Bryant 48,000-Btuh Coil	1.25
Bryant 90,000-Btuh Coil	2.5
1 ft of 1-inch pipe	0.05
1 ft of 1-1/4-inch pipe	0.08
1 ft of 1-1/2-inch pipe	0.11

**CAUTION:** Do not add any chilled-water additive when Ucar-17 is used for freeze protection. Ucar-17 contains adequate inhibitor when used in the recommended concentration as shown in Tables IV and V.

### Freezing Weather Protection

Freeze protection is normally required only on those systems that

- (a) Use hard piping (copper and galvanized)
- (b) Use polyethylene tubing without sufficient length of tubing in conditioned space.

**TABLE IV**

Antifreeze	*Minimum Concentration (Percent of Volume)	Type Chilled-Water Additive
Methanol	20	Borax & Chromate (P/N 62875D1)
Ucar-17	33	None- (See Note 1)

\*For protection at various outdoor ambients, refer to Table V.  
NOTE 1—Ucar-17 is the only approved type of permanent (glycol-base) antifreeze recommended for freeze protection of Model 90-452W Chiller.

**TABLE V**

Lowest Winter Outdoor Temperature (°F)	Percent of Antifreeze Concentration (% of Vol.)	
	Ucar-17	Methanol
20	33	20
15	33	20
10	33	22
5	33	26
0	33	29
-5	36	32
-10	39	34
-15	42	36
-20	45	38
-25	47	43
-30	49	44

(c) Must be operated during winter as well as summer.

(d) Have cooling coil located in unheated area where freezing could occur, such as rooftop unit.

Table IV lists the minimum amount of concentration, and the type of chilled-water additive to use when required.

### Adjusting Chilled-Water Level

1. Turn off gas at main manual shutoff valve and turn off electrical power at disconnect switch.

**WARNING:** To prevent bodily injury, disconnect condenser fans motor leads in the control box.

2. Remove left-side access panel, then remove hand hole cover located on top of chiller tank. See Figure 8.
3. Disconnect water line at chiller inlet. (When installing chilled-water lines, it is advisable to leave this connection open until lines have been flushed.)
4. Fill tank with tap water until distributor pan at top is covered with water. A garden hose is useful for this operation.
5. Turn on electrical power to unit and start pump. Continue to supply water to tank and operate pump until all foreign matter has been flushed from lines, then remove garden hose.
6. Turn off pump. Reconnect water line at chiller inlet.
7. Add water to tank until tank is approximately half full. Replace hand hole cover.
8. Start pump and check for leaks.
9. Adjust operating water level with pump running. This is accomplished by removing drain plug. Operating water level is properly adjusted when water ceases to flow from drain opening. Replace drain plug and turn off pump.
10. Refer to section on "Freezing Weather Protection" on page 7. If freeze protection is not required, omit Steps 11 and 12, and proceed with Step 13. If freeze protection is required, decide on

type antifreeze to use. Step 11, gives procedure for adding Ucar-17 antifreeze. Step 12 covers procedure for adding methanol antifreeze.

11. Adding Ucar-17 - Calculate capacity of chilled-water circuit by using information given in Table III. Refer to Table V and determine amount of antifreeze required. Drain out amount of water equal to amount of antifreeze to be added. Add antifreeze, then check operating level and correct. Omit Steps 12, 13, and 14.

**NOTE:** Do not use any chilled-water additive when Ucar -17 is used in the recommended concentration.

12. Adding methanol antifreeze - Calculate capacity of the chilled-water circuit by using information given in Table III. Refer to Table V and determine amount of antifreeze required. Drain out amount of water equal to amount of antifreeze to be added. Add antifreeze, then check operating level and correct.

**NOTE:** Methanol antifreeze does not contain an inhibitor; therefore, add the required amount of Chilled-Water Additive P/N 62875D1 as described in Step 13.

13. Remove hand hole cover and add contents of Chilled-Water Additive Package P/N 62875D1 to chiller tank. Package supplied is sufficient for systems up to 15 gallons. For systems larger than 15-gallon capacity, add one package for each additional 15 gallons or fraction thereof.
14. Replace hand hole cover. Turn on pump. Pump should operate a minimum of 10 minutes to dissolve all chilled-water additive.
15. Turn off electrical power at disconnect switch. Reconnect condenser fans motor leads in control box. Turn on power at disconnect switch.
16. Replace access panel. Chiller is now ready for operation.

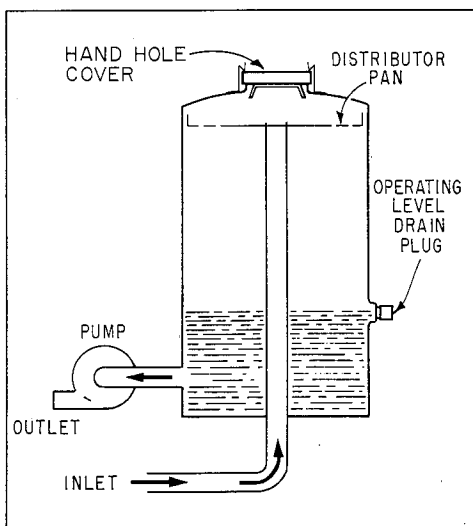

A65084

**Figure 8 - Chiller Tank**

## VI. CHECKING THE UNIT OPERATION

1. Be sure manual gas valve is off. Light pilots as described on Instruction Plate.
2. Turn on manual gas valve with thermostat sub-base switch levers on "cool" and "auto." Set thermostat below room temperature. To check correct operation of electrical circuit, observe operation of gas valve, condenser fan motors, hydraulic pump, and indoor fan. Set thermostat above room temperature and observe that unit shuts off properly.
3. Check indoor fan operation by setting thermostat subbase fan switch lever to "on." Indoor fan should operate continually with thermostat set above or below room temperature.
4. To place system in operation, open main manual gas valve, replace all panels, and set thermostat at desired temperature.

### Control Circuit Description

Refer to Figure 9. Note that 24 volts (transformer secondary voltage) is applied to chiller terminals R and F whenever power is supplied to unit. When thermostat calls for cooling, chiller terminal R is connected to chiller terminal Y through thermostat.

### Automatic Pilot Reignition

The automatic pilot reignition circuit consists of the 1-ohm resistor (11A1), pilot pressure switch (7P), and the pilot and ignition coil assembly (6B). The pilot pressure switch (7P) contacts close when gas is turned on to the unit and current flows from chiller terminal R, through the 1-ohm resistor (11A1), pilot pressure switch (7P), the glow coil of the pilot assembly (6B) via the pilot's normally closed contacts to chiller terminal F, and lights the pilot.

Approximately one minute after the pilot is ignited, heat from pilot will cause normally open contacts of the pilot to close and the normally closed contacts to open.

If the pilot should go out, the normally open pilot contacts (which were closed when the pilot was ignited) will reopen, deenergizing the power relay (2D) and the magnetic gas valve (5B). This will cause all motors (3A1, 3A2, 3C1 & 3C2) to stop and the gas valve to close. The normally closed pilot contacts (which were opened by heat from the pilot) will close and complete the current path to reignite the pilot.

### Cooling Operation

Two current paths are provided from chiller terminal Y to chiller terminal F when the thermostat calls for cooling and the pilots are ignited as described above.

Current flows from chiller terminal Y, through the power relay winding (2D) and through the closed contacts of the pilot (6B) to chiller terminal F. The energized power relay winding (2D) causes the power relay contacts (2D) to close and starts the two fan motors (3C1 & 3C2), the hydraulic pump motor (3A1), and the water pump motor (3A2).



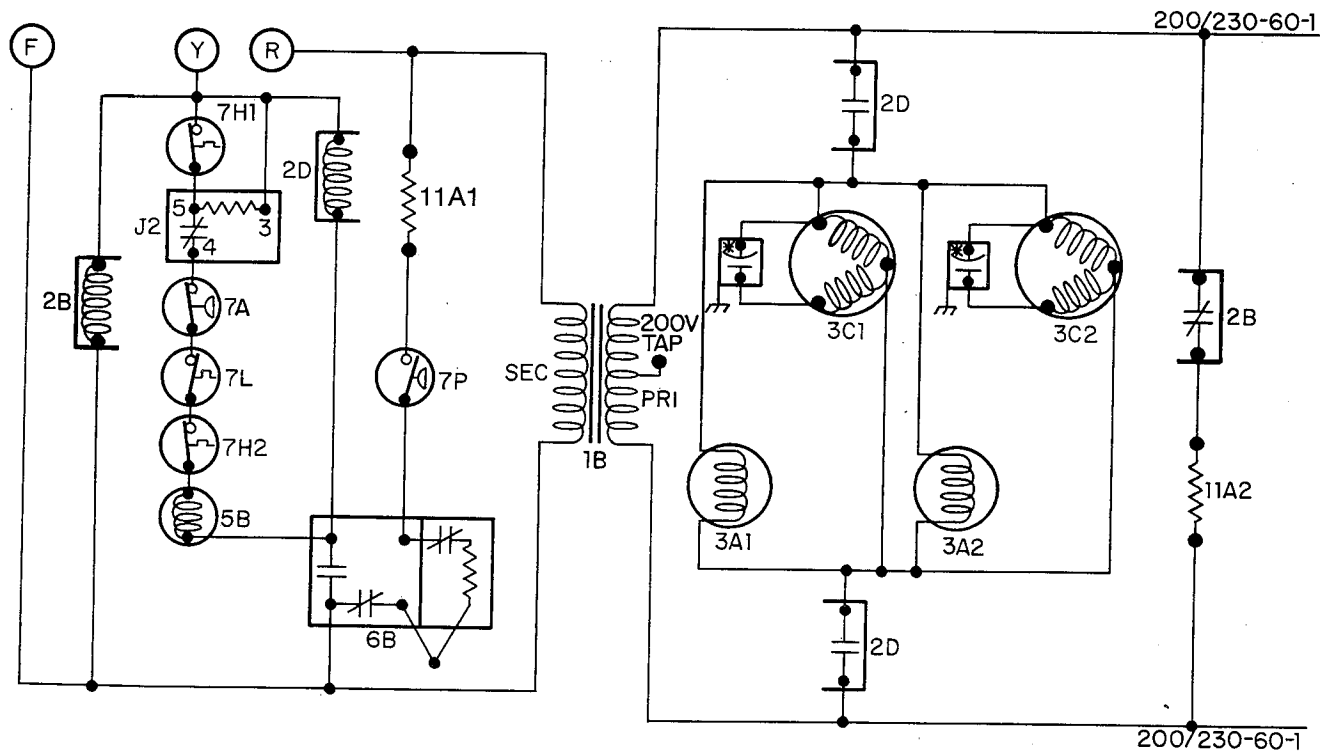

#### LEGEND

- |                                      |  |  |
|--------------------------------------|--|--|
| 1B - Tapped Primary Transformer      | 3C2 - Motor (Fan) (PSC)                                  | 7L - Ambistat (Part Load Control) (SPST) |
| 2B - Pump Heater Relay (SPST-NC)     | 5B - Gas Valve (Magnetic)                                | 7P - Pressure Switch (Pilot Gas) (SPST)  |
| 2D - Power Relay (DPST)              | 6B - Pilot (Reignition)                                  | 11A1 - Resistor                          |
| 2J - Circuit Breaker (Lockout Relay) | 7A - High-Pressure Limit Switch (Auto. Reset) (SPST)     | 11A2 - Pump Heater                       |
| 3A1 - Motor (Hydraulic Pump)         | 7H1 - Limit Switch (High-Temp Cont) (SPST)               |  |
| 3A2 - Motor (Water Pump)             | 7H2 - Limit Switch (Sec. High-Temp. Manual Reset) (SPST) |  |
| 3C1 - Motor (Fan) (PSC)              |  |  |

If any of the original wire, as supplied, must be replaced, use the same or equivalent wire.

**Figure 9 - Model 90-452W Wiring Diagram**

Current also flows from chiller terminal Y, through the high-temperature limit switch (7H1), the closed contacts of the circuit breaker (2J), part load control (7L), high-pressure switch (7A), secondary high-temperature limit switch (7H2), the gas valve coil (5B), and to chiller terminal F. The energized gas valve coil opens the gas valve and supplies gas to the generator burners.

#### Part Load Control

The part load control (7L) circuit is an automatic recycling type of temperature sensitive switch. Connected to the switch is a long capillary tube that is inserted in the chilled-water supply line. The part load control switch contacts open when the chilled-water supply temperature drops below  $40 \pm 1^\circ\text{F}$ . The opening of the part load control switch contacts deenergizes the gas valve and shuts off the gas supply to the burners. The power relay (2D) remains energized and the fan motors (3C1 & 3C2) hydraulic pump motor (3A1), and the water pump motor (3A2) will continue to run.

The part load control switch contacts will close again when the chilled-water temperature rises to  $42 \pm 1^\circ\text{F}$ . The magnetic gas valve will be reenergized and turn the gas on again.

#### High-Temperature Cutoff

The high-temperature cutoff circuit includes a high-temperature limit switch (7H1), located in the front of the generator, plus a circuit breaker (2J) that is located in the control box.

If the generator becomes overheated, the high-temperature limit switch (7H1) will open, providing a current path through the heater element of the circuit breaker (2J). This current flow through the heater causes the normally closed contacts of the circuit breaker to open, removing the 24-volts potential from the magnetic gas valve. The deenergized gas valve will turn off the gas supply to the burners.

The control box cover must be removed to reset the circuit breaker. Pressing the red "reset" button resets the circuit breaker.

A secondary high-temperature limit switch (7H2) is connected in the Y leg of the control circuit to insure the closing of the gas valve in the event the generator overheats and the high-temperature limit switch (7H1) does not open. The secondary high-temperature limit switch is located on the generator header and must be reset manually.

#### Hydraulic Pump Heater

Model 90-452W is equipped with a hydraulic pump

**TABLE VI—Manifold Pressure  
(Inches w.c.)**

Btu Value	Specific Gravity				
	0.59	0.61	0.63	0.65	0.67
900	3.9"	4.0"	4.1"	4.2"	4.3"
950	3.5"	3.6"	3.7"	3.8"	3.9"
1000	3.1"	3.2"	3.3"	3.4"	3.5"
1025	3.0"	3.1"	3.2"	3.3"	3.4"
1050	2.8"	2.9"	3.0"	3.1"	3.2"
1100	2.6"	2.7"	2.8"	2.9"	3.0"

For manifold pressures exceeding 3.0 inches  $\pm$  3 inches, consult your Bryant Distributor.

heater circuit that permits operation of the unit at outdoor ambient temperatures down to -30°F. The pump heater circuit consists of a hydraulic pump heater (11A2) and a pump heater relay (2B).

The pump heater is connected in series with the normally closed contacts of the pump heater relay. Current flows through the heater only when there is no demand for cooling by the thermostat. When the thermostat calls for cooling, the pump heater relay winding is energized and opens the normally closed contacts of the pump heater relay and removes the power supply voltage from the pump heater.

#### VII. ADJUSTING GAS INPUT

The gas input must be checked and adjusted if necessary to agree with that shown on the rating plate of the unit (246,000 Btuh). The burners are equipped with fixed orifices drilled as follows: Natural gas No. 36 drill; Propane gas No. 52 drill.

The natural gas units are equipped with adjustable gas pressure regulators set at factory for 3.0-inches w.c. manifold pressure. The propane gas units are not equipped with a pressure regulator.

Check natural gas units by one of the following methods:

1. Measure gas at meter. Be sure all other gas ap-

pliances are turned off. Increase or decrease input to burners by adjustment of gas pressure regulator.

2. Set manifold pressure according to Table VI for Btu value and specific gravity of gas to be supplied to unit. Connect manometer to 1/8-inch pressure tap on manifold and, with unit in operation, set correct pressure by adjustment of gas pressure regulator.

Example: Natural Gas

1025 Btu

0.63 Specific Gravity

1. From Table VI, manifold pressure is 3.2 inches w.c.
2. With manometer connected to manifold, set pressure at 3.2 inches by adjusting gas pressure regulator.

Check propane gas units as follows:

The burner orifices are sized for rated input with a manifold pressure of 11.0 inches w.c. Connect manometer to 1/8-inch pressure tap on unit manifold and adjust regulator at supply tank to provide a manifold pressure of 11.0 inches w.c.

**CAUTION:** The unit may be run for short periods with the panel removed. Prolonged operation with panels removed should not be attempted.

#### VIII. BALANCING THE SYSTEM

After the unit is operating and the input has been measured and adjusted to agree with the rating plate requirements, balance the system.

Any approved method of checking the airflow over the water coil may be utilized. Reference is made to the Bryant Service Manual on Gas Air Conditioning for a review of standard methods. Do not purge non-condensibles or check solution level.

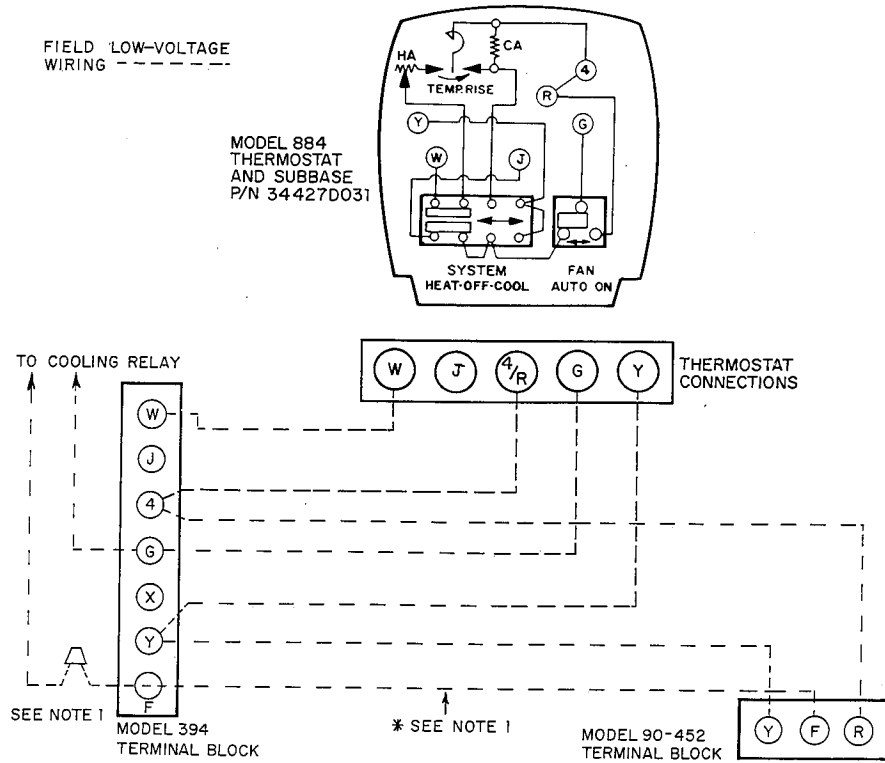

A72594

NOTE 1: Field wire from terminal "F" at chiller unit must extend through hole at furnace terminal "F" and connect to cooling relay as shown. If cooling relay is factory-installed, remove lead from terminal "X." Strip end, and connect as shown.

NOTE 2: This wiring procedure will not allow manual fan operation if chiller unit power is turned off.

Figure 10 - Connecting 90-452W Chiller to Models 190- or 220-394, Series E, F, or G Furnace

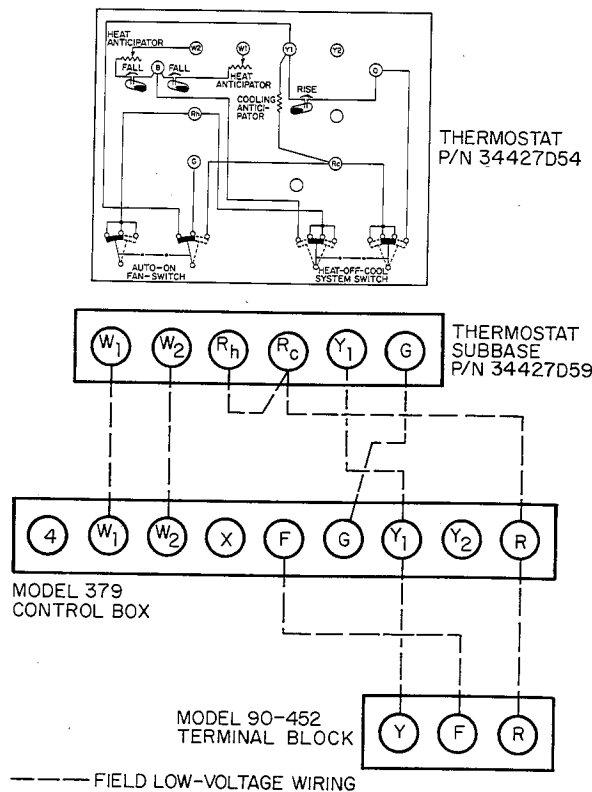

A72593

Figure 11 - Connecting 90-452W Chiller to Model 90W-379 Furnace

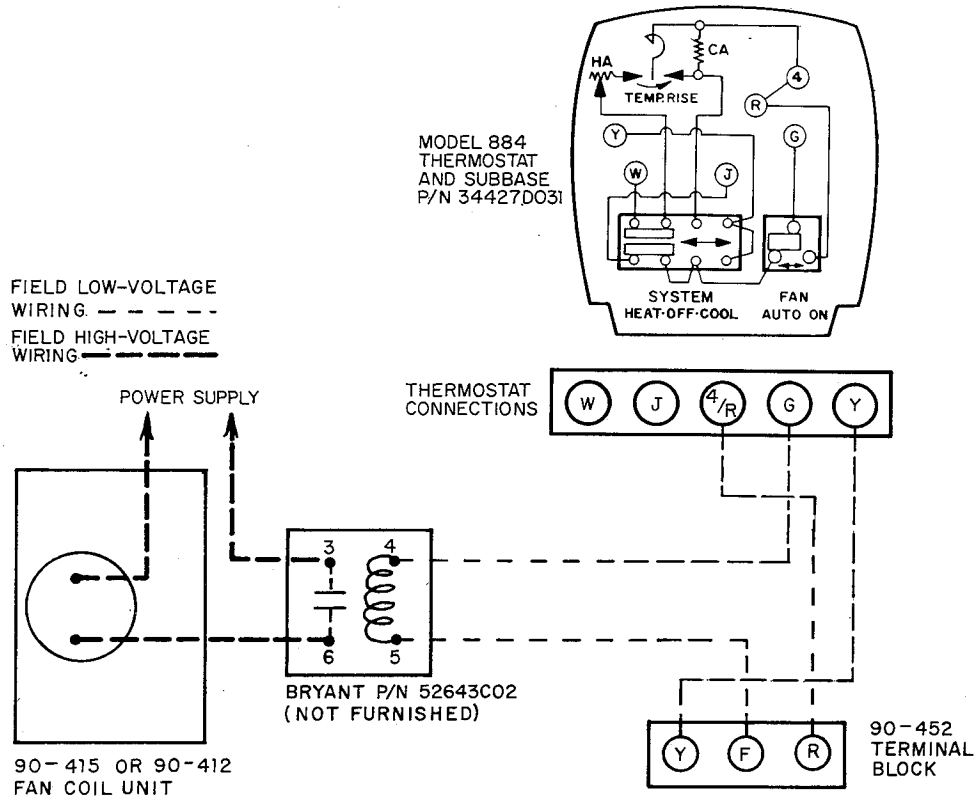

B71083

Figure 12 - Connecting 90-452W Chiller to Models 90-412 or 90-415 Fan Coil Unit