

Q175C Condensing Boiler

Standard Features

- Onboard outdoor reset control system with sensor standard
- Prebuilt plumbing kit with insulated Low Loss Header
- Priority DHW standard (3 way valve not included)
- Domestic hot water plate warming
- Built in DHW 6.6 gallon indirect tank
- Modulating Ceramic premix burner
- 5:1 turn down ratio
- Spark ignition
- Exceeds SCAQMD 1146.2 Low NO_x requirements
- Stainless Steel Water tube condensing heat exchanger
- Direct Vent sealed combustion
- Concentric and twin pipe venting adapters included
- Approved for room and closet installations

Optional Accessories

- RS100 Single zone controller
- Flue Gas temperature sensor
- Room Air Filter
- NG to LP conversion Kit
- LP to NG Conversion Kit

SPECIFICATIONS

General Specifications		
	Units	
Water content	gal	1.8
Max. supply boiler temperature	°F	176
Max operating pressure	psi	45
Relief valve rating	MBH	375
Relief valve pressure rating	psi	30
Dry weight	lbs	196
Min inlet gas pressure NG	"W.C.	4.0"
Max inlet gas pressure NG	"W.C.	10.5"
Min inlet gas pressure LP	"W.C.	8.0"
Max inlet gas pressure LP	"W.C.	14.0"
Max equivalent exhaust vent length	ft	80
Max equivalent combustion air vent length	ft	80
Approved venting materials		Polypropylene, Stainless Steel, PVC, CPVC

Performance Specifications		
	Units	
Fuel Type		NG/LP
Input	MBH	175
Heating Capacity	MBH	161
AFUE (I=B=R)	%	95.7
Part Load Efficiency (EN677)	%	98.5
DHW flow rate 75°F ΔT	Gpm	4.1

Electrical Specifications		
	Units	
Electrical Voltage Mains	V/Hz	120/60
Electrical Voltage Controls	V	24
Power Consumption Max Load	W	210
Power Consumption Stand by Load	W	14
Recommended Circuit breaker rating	A	15

Rinnai is continually updating and improving products; therefore, specifications are subject to change without prior notice. Local, state, provincial and federal codes must be adhered to prior to installation.

DIMENSIONS

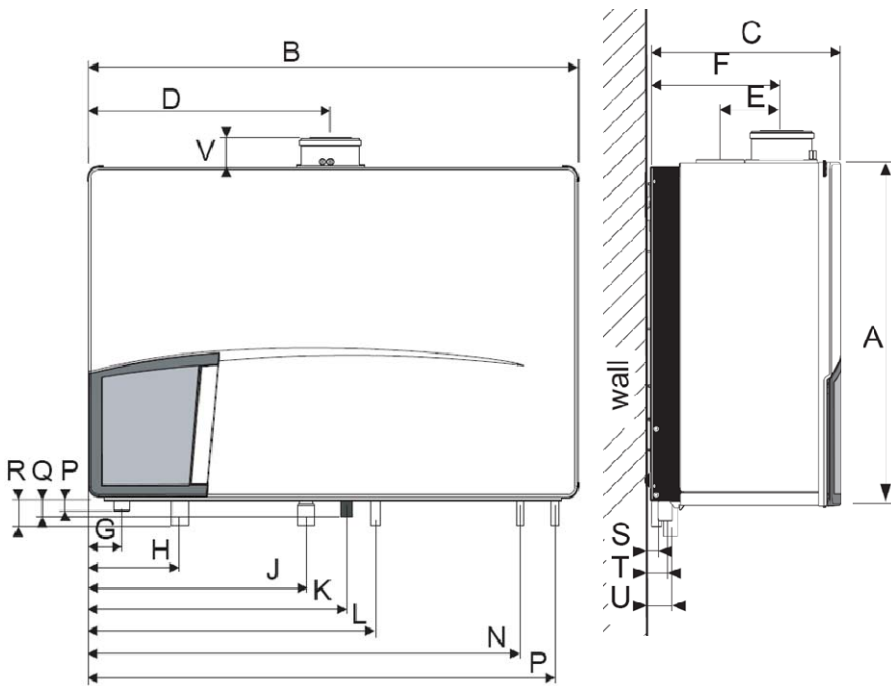

		inch / mm
A	Height	26.8 / 680
B	Width	39.4 / 1000
C	Depth	15.2 / 385
D	Left side / vent	19.5 / 495
E	Center to center / vent and air supply	4.7 / 120
F	Back / vent	10.6 / 270
G	Left side / gas pipe	2.6 / 65
H	Left side / supply pipe	7.3 / 185
J	Left side / return pipe	17.5 / 445
K	Left side / condensate pipe	20.9 / 530
L	Left side / expansion pipe	23.2 / 590
N	Left side / cold water pipe	34.8 / 885
O	Left side / hot water pipe	37.6 / 955
P	Pipe length of g	0.7 / 18
Q	Pipe length of c	2 / 50
R	Pipe length of e, f, k, r, and w	2.3 / 60
S	Back / center of pipe c	1 / 25
T	Back / Center of pipe g	1.6 / 40
U	Back, / center of pipe e, f, k, r, and w	2 / 50
V	Pipe length vent co-axial Pipe length vent parallel	2.6 / 65 5.8 / 147

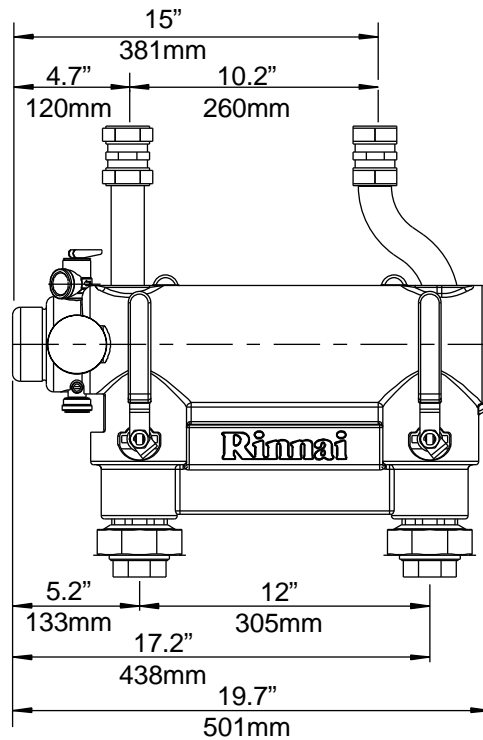
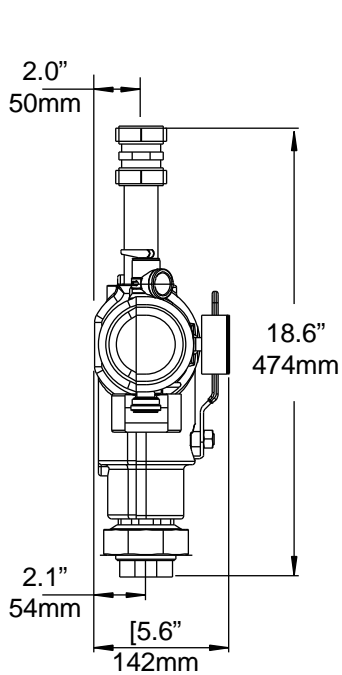

Clearances

	Minimum required clearance to combustibles and non-combustibles	Recommended service clearances
	inch / mm	inch / mm
Top	2 / 50	10 / 250
Back	0	0
Front	6 / 150	24 / 600
Left side	2 / 50	2 / 50
Right side	2 / 50	2 / 50
Floor / Ground	12 / 300	30 / 762
Vent	0	0