

ALTO SHAAM®
Combitherm®

Combination
Oven / Steamer

ES ELECTRIC
SERIES



6•10

10•10

7•14

10•18

12•20

20•20

VHES-5

VHES-10



INSTALLATION

W164 N9221 Water Street • P.O. Box 450 • Menomonee Falls, Wisconsin 53052-0450 USA
PHONE: 262.251.3800 • 800.558.8744 USA / CANADA FAX: 262.251.7067 • 800.329.8744 U.S.A. ONLY
WWW.ALTO-SHAAM.COM

General Information	
Delivery / Unpacking	1.
Safety Procedures and Precautions	2.

Specifications	
Options	3.
6•10es	4.
6•10esi	5.
6•10esiN	6.
10•10es	7.
10•10esi	8.
10•10esiN	9.
7•14es	10.
7•14esi	11.
10•18es	12.
10•18esi	13.
12•20es	14.
20•20es	15.

Installation Requirements	
Installation Codes & Standards	16.
Ventilation General Requirements	17.
Positioning on Site	17.
Minimum Clearance Requirements	17.
Positioning Requirements	18.
Electrical Requirements	19.
Drip Tray Installation	20.
Mobile Equipment Restraint	20.
Water Quality Requirements	21.
Water Connection	22.
Water Filtration System	23.
Water Drainage	24.

Installation Checklist	25.
---	-----

Error Codes	
Control Reset	26.
Service Mode and Error Codes	26.
Emergency Operation	29.

Ventless Hood Option	
Condensate Drain	30.
Opening Mechanism	30.
Operation	31.
Interlock Switches	31.
Reset Switch	31.
Cleaning and Maintenance	32.
Filters	32.

Equipment Limited Warranty	33.
---	-----

Transportation Damage and Claims	34.
---	-----

ALTO SHAAM®

DELIVERY

This Alto-Shaam appliance has been thoroughly tested and inspected to insure only the highest quality unit is provided. Upon receipt, check for any possible shipping damage and report it at once to the delivering carrier. See *Transportation Damage and Claims section located in this manual.*

This appliance, complete with unattached items and accessories, may have been delivered in one or more packages. Check to ensure that all standard items and options have been received with each model as ordered.

Save all the information and instructions packed with the appliance. Complete and return the warranty card to the factory as soon as possible to assure prompt service in the event of a warranty parts and labor claim.

This manual must be read and understood by all people using or installing the equipment model. Contact the Alto-Shaam service department if you have any questions concerning installation, operation, or maintenance.

NOTE: All claims for warranty must include the full model number and serial number of the unit.

UNPACKING

1. Carefully remove the appliance from the carton or crate.

NOTE: Do not discard the carton and other packaging material until you have inspected the unit for hidden damage and tested it for proper operation.



2. Read all instructions in this manual carefully before initiating the installation of this appliance.

DO NOT DISCARD THIS MANUAL.

This manual is considered to be part of the appliance and is to be provided to the owner or manager of the business or to the person responsible for training operators. *Additional manuals are available from the Alto-Shaam service department.*

3. Remove all protective plastic film, packaging materials, and accessories from the appliance before connecting electrical power. Store any accessories in a convenient place for future use.

CAUTION



**TO PREVENT PERSONAL INJURY,
USE CAUTION WHEN MOVING OR
LEVELING THIS APPLIANCE.**

THE INFORMATION CONTAINED IN THIS MANUAL IS IMPORTANT FOR THE PROPER INSTALLATION OF THIS OVEN. PLEASE READ CAREFULLY AND RETAIN FOR FUTURE REFERENCE.

IMPROPER CONNECTION OF THIS APPLIANCE WILL NULLIFY ALL WARRANTIES.

LES INFORMATIONS CONTENUES DANS CE MANUEL SONT IMPORTANTES POUR L'INSTALLATION L'UTILISATION ET L'ENTRETIEND DE CE FOUR. S'IL VOUS PLAIT LISEZ-LE TRES ATTENTIVEMENT ET CONSERVEZ-LE.

LA NON-APPLICATION DE CES CONSIGNES ANNULE TOUTES GARANTIES.

SAFETY PROCEDURES AND PRECAUTIONS

Knowledge of proper procedures is essential to the safe operation of electrically and/or gas energized equipment. In accordance with generally accepted product safety labeling guidelines for potential hazards, the following signal words and symbols may be used throughout this manual.

DANGER



Used to indicate the presence of a hazard that **WILL** cause severe personal injury, death, or substantial property damage if the warning included with this symbol is ignored.

WARNING



Used to indicate the presence of a hazard that **CAN** cause personal injury, possible death, or major property damage if the warning included with this symbol is ignored.

CAUTION



Used to indicate the presence of a hazard that can or will cause minor or moderate personal injury or property damage if the warning included with this symbol is ignored.

CAUTION

Used to indicate the presence of a hazard that can or will cause minor personal injury, property damage, or a potential unsafe practice if the warning included with this symbol is ignored.

NOTE: Used to notify personnel of installation, operation, or maintenance information that is important but not hazard related.

1. This appliance is intended to cook, hold or process foods for the purpose of human consumption. No other use for this appliance is authorized or recommended.
2. This appliance is intended for use in commercial establishments where all operators are familiar with the purpose, limitations, and associated hazards of this appliance. Operating instructions and warnings must be read and understood by all operators and users.
3. Any troubleshooting guides, component views, and parts lists included in this manual are for general reference only and are intended for use by qualified technical personnel.
4. This manual should be considered a permanent part of this appliance. This manual and all supplied instructions, diagrams, schematics, parts lists, notices, and labels must remain with the appliance if the item is sold or moved to another location.

NOTE

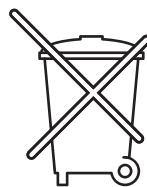

For equipment delivered for use in any location regulated by the following directive:

DO NOT DISPOSE OF ELECTRICAL OR ELECTRONIC EQUIPMENT WITH OTHER MUNICIPAL WASTE.

CAUTION



WHEN WELDING ANY STAINLESS STEEL COMPONENTS ON THIS APPLIANCE, THE ELECTRONIC CONTROL BOARDS MUST BE ISOLATED FROM THE APPLIANCE.

- CombiGuard™ Triple-Guard Water Filtration System
(INCLUDES 1 CARTRIDGE) FI-23014

- CombiGuard™ Replacement Filter FI-26356

- Fry Basket, 12" x 20" (325mm x 530mm) BS-26730

- Grilling Grate,
12" x 20" (325mm x 530mm) SH-26731

- Oven Cleaner — CE-24750
SPECIALLY FORMULATED FOR COMBITHERM OVENS
➔ TWELVE (12) CONTAINERS/CASE, 1 QUART (C. 1 LITER) EACH

- Scale Free™ CE-27889
(CITRUS BASED, NON-CORROSIVE DELIMING PRODUCT)
CASE = FOUR 4-LB BOTTLES; 4-LB BOTTLE MAKES 10 GALLONS

- Service Start-Up Check SPECIFY AS REQUIRED
AVAILABLE THROUGH AN ALTO-SHAAM FASTEAM CENTER

- Computer Software Options** 5005676
Not available on S-Control Models.
REFER TO HACCP SPECIFICATION SHEET #9015
FOR APPLICABLE PART NUMBERS

 - HACCP Documentation**

 - HACCP Documentation with Kitchen Management**



 - Wireless HACCP Documentation with Kitchen Management**



IEEE 802.11b STANDARDS



Six (6) Chicken Roasting Rack
(PAN NOT INCLUDED) SH-23000

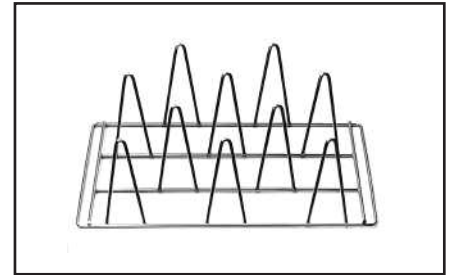

Ten (10) Chicken Roasting Rack
SH-22634



Fry Basket BS-26730



Grilling Grate SH-26731

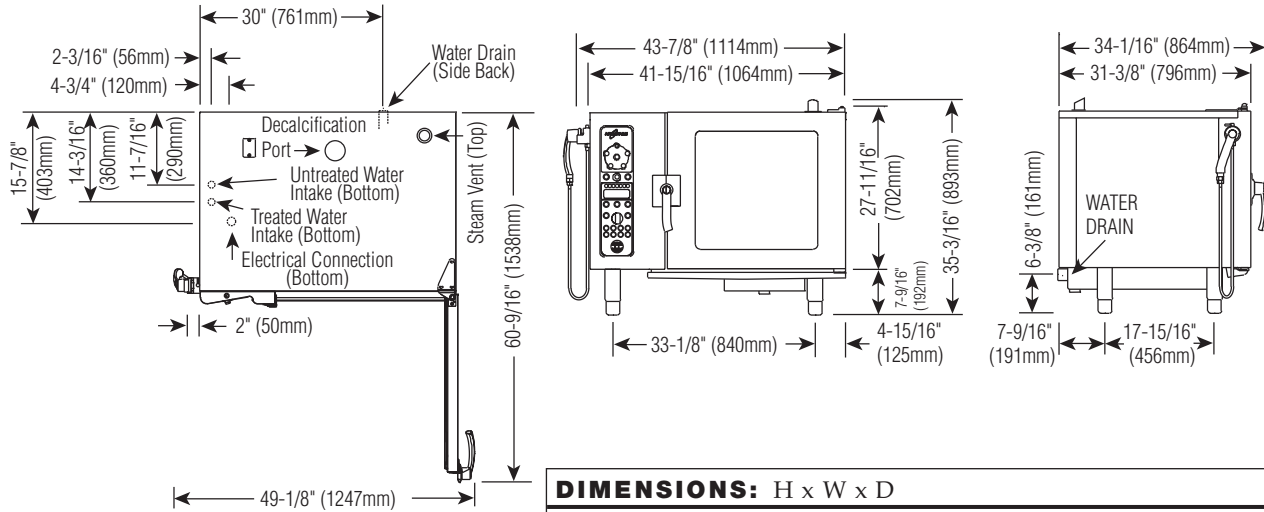

DIMENSIONS: H x W x D	
EXTERIOR:	35-3/16" x 43-7/8" x 34-1/16" (893mm x 1114mm x 864mm)
EXTERIOR WITH RETRACTABLE DOOR:	35-3/16" x 47-7/8" x 34-1/16" (893mm x 1216mm x 864mm)
INTERIOR:	17-3/4" x 23-1/2" x 21-1/16" (450mm x 597mm x 535mm)

INSTALLATION REQUIREMENTS

Oven must be installed level.
 Hood installation is required.
 Water supply shut-off valve and back-flow preventer.

WATER REQUIREMENTS

TWO (2) COLD WATER INLETS - DRINKING QUALITY
 ONE (1) TREATED WATER INLET: 3/4" NPT*
 ONE (1) UNTREATED WATER INLET: 3/4" NPT*
 LINE PRESSURE: 30 to 90 psi 2.8 to 6.2 bar
WATER DRAIN: 1-1/2" CONNECTION WITH AIR GAP
 * Can manifold off of one 3/4" line.

WATER QUALITY MINIMUM STANDARDS

USING A WATER SUPPLY NOT MEETING ALTO-SHAAM'S MINIMUM WATER QUALITY STANDARDS WILL VOID THIS WARRANTY. It is the responsibility of the purchaser to ensure that incoming water supply is compliant with the specifications listed through adequate treatment measures. Installation of the CombiGuard™ Water Filtration System is recommended, but this system may not address all water quality issues present.

Contaminant	Inlet Water Requirements (untreated water)
Free Chlorine	Less than 0.1 ppm (mg/L)
Hardness	Less than 3 gpg (52 ppm)
Chloride	Less than 30 ppm (mg/L)
pH	7.0 to 8.5
Alkalinity	Less than 50 ppm (mg/L)
Silica	Less than 12 ppm (mg/L)
Total Dissolved Solids (tds)	Less than 60 ppm

CLEARANCE REQUIREMENTS

LEFT: 6" (152mm) PLUS SERVICE ACCESS: 18" (457mm) RECOMMENDED 20" (508mm) FROM HEAT PRODUCING EQUIPMENT
RIGHT: 4" (102mm) **TOP:** 20" (508mm) FOR AIR MOVEMENT
BACK: 4" (102mm) **BOTTOM:** 5-1/8" (130mm) FOR LEGS
 COUNTER-TOP INSTALLATIONS MUST MAINTAIN 4" (102mm) MINIMUM CLEARANCE FROM COUNTER SURFACE.

ELECTRICAL

	VOLTAGE	PHASE	CYCLE/HZ	AWG	AMPS	kW
208-240	at 208	1*	50/60	2 Wire plus ground	40.5	8.4
	at 240			AWG 6	47.0	11.2
208-240	at 208	3	50/60	3 Wire plus ground	23.5/ph	8.4
	at 240			AWG 8	27.0/ph	11.2
380-415	at 380	3	50/60	4 Wire plus ground	13.0/ph	8.4
	at 415			AWG 12	16.0/ph	11.2
440-480	at 440	3*	50/60	3 Wire plus ground	20.0/ph	15.4
	at 480			AWG 8	22.0/ph	18.4

* ELECTRICAL SERVICE CHARGE APPLIES

WEIGHT		CAPACITY	
NET	360 lb (163 kg)	FULL-SIZE PANS:	20" x 12" x 2-1/2" Six (6)
		GN 1/1:	530 x 325 x 65mm Six (6)
SHIP	484 lb (220 kg)	HALF-SIZE SHEET PANS:*	18" x 13" x 1" Six (6)
CRATE	40" x 48" x 40" EST.	ON WIRE SHELVES ONLY	
DIMENSIONS: (1016 x 1219 x 1016mm)		72 lb (33 kg) MAXIMUM	
		VOLUME MAXIMUM: 45 QUARTS (57 LITERS)	

* ADDITIONAL WIRE SHELVES REQUIRED FOR MAXIMUM CAPACITY

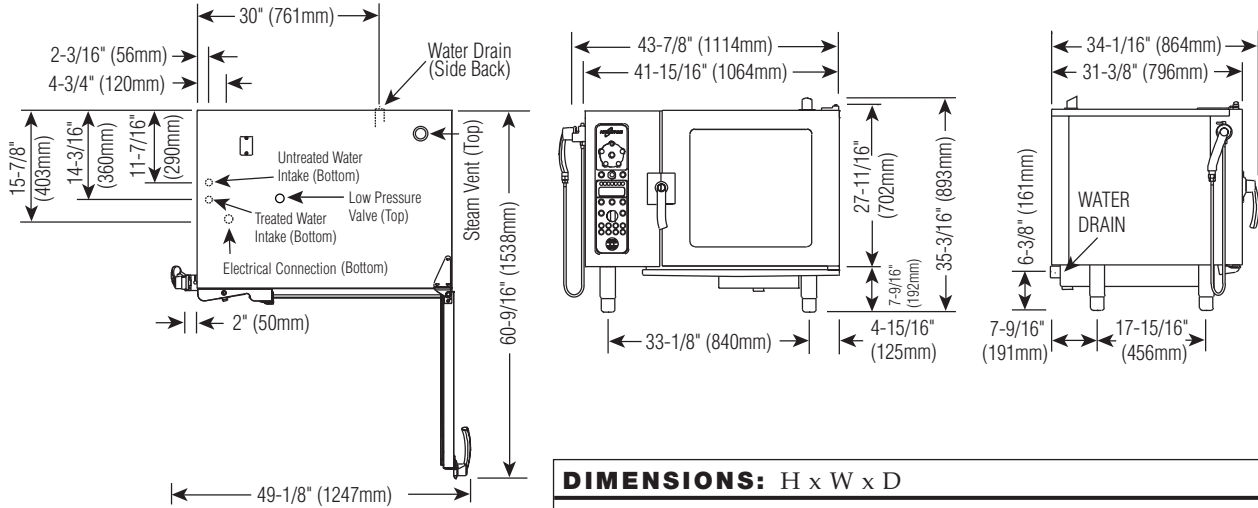

DIMENSIONS: H x W x D	
EXTERIOR:	35-3/16" x 43-7/8" x 34-1/16" (893mm x 1114mm x 864mm)
EXTERIOR WITH RETRACTABLE DOOR:	35-3/16" x 47-7/8" x 34-1/16" (893mm x 1216mm x 864mm)
INTERIOR:	17-3/4" x 23-1/2" x 21-1/16" (450mm x 597mm x 535mm)

INSTALLATION REQUIREMENTS
 Oven must be installed level.
 Hood installation is required.
 Water supply shut-off valve and back-flow preventer.

WATER REQUIREMENTS
TWO (2) COLD WATER INLETS - DRINKING QUALITY
ONE (1) TREATED WATER INLET: 3/4" NPT*
ONE (1) UNTREATED WATER INLET: 3/4" NPT*
LINE PRESSURE: 30 to 90 psi 2.8 to 6.2 bar
WATER DRAIN: 1-1/2" CONNECTION WITH AIR GAP
 * Can manifold off of one 3/4" line.

WATER QUALITY MINIMUM STANDARDS
 USING A WATER SUPPLY NOT MEETING ALTO-SHAAM'S MINIMUM WATER QUALITY STANDARDS WILL VOID THIS WARRANTY. It is the responsibility of the purchaser to ensure that incoming water supply is compliant with the specifications listed through adequate treatment measures. Installation of the CombiGuard™ Water Filtration System is recommended, but this system may not address all water quality issues present.

Contaminant	Inlet Water Requirements (untreated water)
Free Chlorine	Less than 0.1 ppm (mg/L)
Hardness	Less than 3 gpg (52 ppm)
Chloride	Less than 30 ppm (mg/L)
pH	7.0 to 8.5
Alkalinity	Less than 50 ppm (mg/L)
Silica	Less than 12 ppm (mg/L)
Total Dissolved Solids (tds)	Less than 60 ppm

CLEARANCE REQUIREMENTS
LEFT: 6" (152mm) **PLUS SERVICE ACCESS:** 18" (457mm) **RECOMMENDED**
20" (508mm) FROM HEAT PRODUCING EQUIPMENT
RIGHT: 4" (102mm) **TOP:** 20" (508mm) **FOR AIR MOVEMENT**
BACK: 4" (102mm) **BOTTOM:** 5-1/8" (130mm) **FOR LEGS**
 COUNTER-TOP INSTALLATIONS MUST MAINTAIN 4" (102mm) MINIMUM CLEARANCE FROM COUNTER SURFACE.

ELECTRICAL				6 • 10 Esi		6 • 10 Esi/sk		
	VOLTAGE	PHASE	CYCLE/HZ	AWG	AMPS	kW	AMPS	kW
208-240	at 208	1*	50/60	2 Wire plus ground	41.0	8.5	43.3	9.0
	at 240			AWG 6	47.0	11.2	48.0	11.7
208-240	at 208	3	50/60	3 Wire plus ground	23.3/ph	8.4	25.0/ph	9.0
	at 240			AWG 8	27.0/ph	11.2	28.2/ph	11.7
380-415	at 380	3	50/60	4 Wire plus ground	13.0/ph	8.5	14.0/ph	9.0
	at 415			AWG 12	15.6/ph	11.2	16.3/ph	11.7
440-480	at 440	3*	50/60	3 Wire plus ground	20.0/ph	15.4	21.0/ph	15.9
	at 480			AWG 8	22.0/ph	18.4	23.0/ph	18.9

* ELECTRICAL SERVICE CHARGE APPLIES

WEIGHT			CAPACITY		
NET	343 lb	(156 kg)	FULL-SIZE PANS: 20" x 12" x 2-1/2"	Six (6)	Four (4)
SHIP	467 lb	(212 kg)	GN 1/1: 530 x 325 x 65mm	Six (6)	Four (4)
CRATE	40" x 48" x 40" EST.		HALF-SIZE SHEET PANS:* 18" x 13" x 1"	Six (6)	Five (5)
DIMENSIONS: (1016 x 1219 x 1016mm)			ON WIRE SHELVES ONLY		
			72 lb (33 kg) MAXIMUM		
			VOLUME MAXIMUM: 45 QUARTS (57 LITERS)		

* ADDITIONAL WIRE SHELVES REQUIRED FOR MAXIMUM CAPACITY

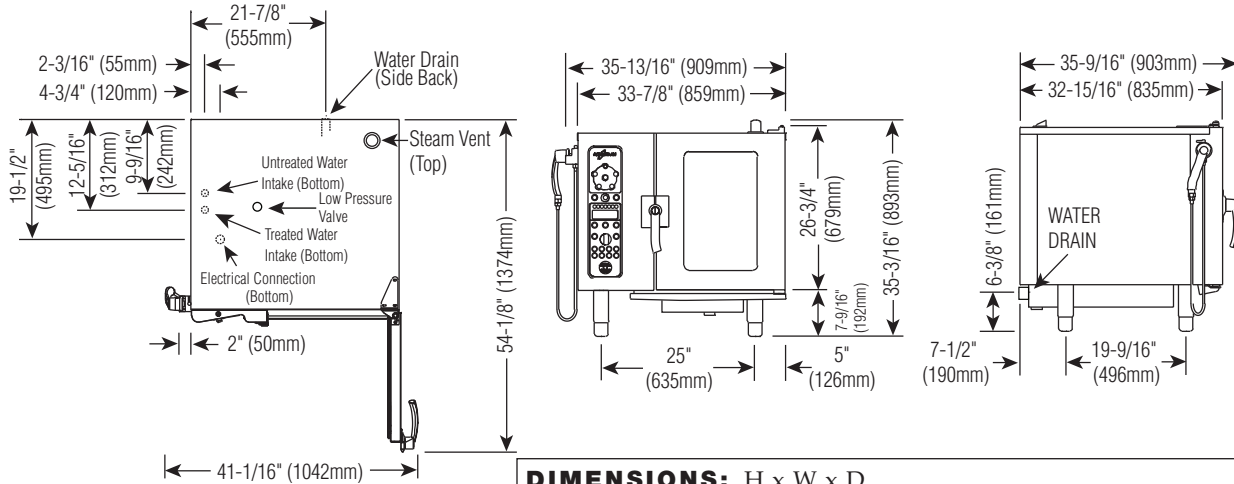

DIMENSIONS: H x W x D	
EXTERIOR:	35-3/16" x 35-13/16" x 35-9/16" (893mm x 909mm x 903mm)
EXTERIOR WITH RETRACTABLE DOOR:	35-3/16" x 39-13/16" x 35-9/16" (893mm x 1011mm x 903mm)
INTERIOR:	17-3/4" x 13-1/4" x 26-1/4" (450mm x 387mm x 665mm)

INSTALLATION REQUIREMENTS

Oven must be installed level.
Hood installation is required.
Water supply shut-off valve and back-flow preventer.

WATER REQUIREMENTS

TWO (2) COLD WATER INLETS - DRINKING QUALITY

ONE (1) TREATED WATER INLET: 3/4" NPT*
ONE (1) UNTREATED WATER INLET: 3/4" NPT*
LINE PRESSURE: 30 to 90 psi 2.8 to 6.2 bar

WATER DRAIN: 1-1/2" CONNECTION WITH AIR GAP

* Can manifold off of one 3/4" line.

WATER QUALITY MINIMUM STANDARDS

USING A WATER SUPPLY NOT MEETING ALTO-SHAAM'S MINIMUM WATER QUALITY STANDARDS WILL VOID THIS WARRANTY. It is the responsibility of the purchaser to ensure that incoming water supply is compliant with the specifications listed through adequate treatment measures. Installation of the CombiGuard™ Water Filtration System is recommended, but this system may not address all water quality issues present.

Contaminant	Inlet Water Requirements (untreated water)
Free Chlorine	Less than 0.1 ppm (mg/L)
Hardness	Less than 3 gpg (52 ppm)
Chloride	Less than 30 ppm (mg/L)
pH	7.0 to 8.5
Alkalinity	Less than 50 ppm (mg/L)
Silica	Less than 12 ppm (mg/L)
Total Dissolved Solids (tds)	Less than 60 ppm

CLEARANCE REQUIREMENTS

LEFT: 6" (152mm) PLUS SERVICE ACCESS: 18" (457mm) RECOMMENDED 20" (508mm) FROM HEAT PRODUCING EQUIPMENT

RIGHT: 4" (102mm) TOP: 20" (508mm) FOR AIR MOVEMENT

BACK: 4" (102mm) BOTTOM: 5-1/8" (130mm) FOR LEGS

COUNTER-TOP INSTALLATIONS MUST MAINTAIN 4" (102mm) MINIMUM CLEARANCE FROM COUNTER SURFACE.

ELECTRICAL					6•10 EsiN		6•10 EsiN/sk	
	VOLTAGE	PHASE	CYCLE/HZ	AWG	AMPS	kW	AMPS	kW
208-240	at 208	1*	50/60	2 Wire plus ground	41.0	8.5	43.3	9.0
	at 240			AWG 6	47.0	11.2	48.0	11.7
208-240	at 208	3	50/60	3 Wire plus ground	23.3/ph	8.4	25.0/ph	9.0
	at 240			AWG 8	27.0/ph	11.2	28.2/ph	11.7
350-415	at 380	3	50/60	4 Wire plus ground	13.0/ph	8.5	14.0/ph	9.0
	at 415			AWG 12	15.6/ph	11.2	16.3/ph	11.7
440-480	at 440	3*	50/60	3 Wire plus ground	20.0/ph	15.4	21.0/ph	15.9
	at 480			AWG 8	22.0/ph	18.4	23.0/ph	18.9

* ELECTRICAL SERVICE CHARGE APPLIES

WEIGHT			CAPACITY	
NET	348 lb	(158 kg)	FULL-SIZE PANS: 20" x 12" x 2-1/2" GN 1/1: 530 x 325 x 65mm	Six (6) Six (6)
SHIP	472 lb	(214 kg)	HALF-SIZE PANS: 10" x 12" x 2-1/2" GN 1/2: 265 x 325 x 65mm	Twelve (12) Twelve (12)
CRATE	40" x 37" x 40" EST.		HALF-SIZE SHEET PANS:* 18" x 13" x 1" ON WIRE SHELVES ONLY	Six (6) Four (4) Four (4) Eleven (11) Eleven (11) Five (5)
DIMENSIONS:	(1016 x 940 x 1016mm)		72 lb (33 kg) MAXIMUM VOLUME MAXIMUM: 45 QUARTS (57 LITERS)	

* ADDITIONAL WIRE SHELVES REQUIRED FOR MAXIMUM CAPACITY

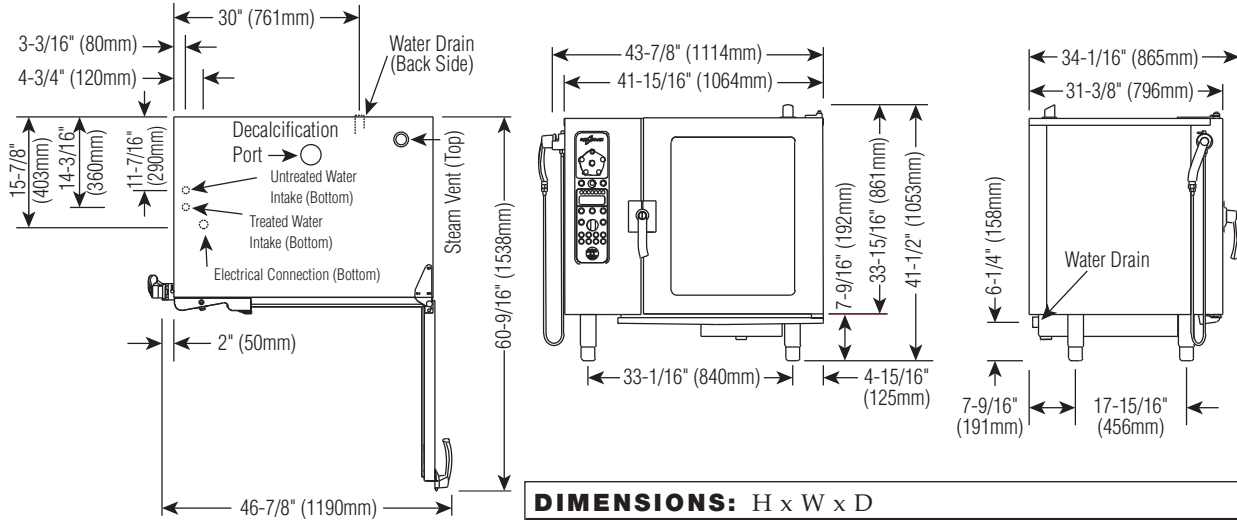

DIMENSIONS: H x W x D	
EXTERIOR:	41-1/2" x 43-7/8" x 34-1/16" (1053mm x 1114mm x 865mm)
EXTERIOR WITH RETRACTABLE DOOR:	41-1/2" x 47-7/8" x 34-1/16" (1053mm x 1216mm x 865mm)
INTERIOR:	27" x 23-1/2" x 21-1/16" (685mm x 597mm x 535mm)

INSTALLATION REQUIREMENTS

Oven must be installed level.
Hood installation is required.
Water supply shut-off valve and back-flow preventer.

WATER REQUIREMENTS

TWO (2) COLD WATER INLETS - DRINKING QUALITY

ONE (1) TREATED WATER INLET: 3/4" NPT*
ONE (1) UNTREATED WATER INLET: 3/4" NPT*
LINE PRESSURE: 30 to 90 psi 2.8 to 6.2 bar

WATER DRAIN: 1-1/2" CONNECTION WITH AIR GAP
* Can manifold off of one 3/4" line.

WATER QUALITY MINIMUM STANDARDS

USING A WATER SUPPLY NOT MEETING ALTO-SHAAM'S MINIMUM WATER QUALITY STANDARDS WILL VOID THIS WARRANTY. It is the responsibility of the purchaser to ensure that incoming water supply is compliant with the specifications listed through adequate treatment measures. Installation of the CombiGuard™ Water Filtration System is recommended, but this system may not address all water quality issues present.

Contaminant	Inlet Water Requirements (untreated water)
Free Chlorine	Less than 0.1 ppm (mg/L)
Hardness	Less than 3 gpg (52 ppm)
Chloride	Less than 30 ppm (mg/L)
pH	7.0 to 8.5
Alkalinity	Less than 50 ppm (mg/L)
Silica	Less than 12 ppm (mg/L)
Total Dissolved Solids (tds)	Less than 60 ppm

CLEARANCE REQUIREMENTS

LEFT: 6" (152mm) PLUS SERVICE ACCESS: 18" (457mm) RECOMMENDED 20" (508mm) FROM HEAT PRODUCING EQUIPMENT

RIGHT: 4" (102mm) TOP: 20" (508mm) FOR AIR MOVEMENT

BACK: 4" (102mm) BOTTOM: 5-1/8" (130mm) FOR LEGS

COUNTER-TOP INSTALLATIONS MUST MAINTAIN 4" (102mm) MINIMUM CLEARANCE FROM COUNTER SURFACE.

ELECTRICAL

	VOLTAGE	PHASE	CYCLE/HZ	AWG	AMPS	kW
208-240	at 208	1*	50/60	2 Wire plus ground	67.0	13.9
	at 240			AWG 3	77.0	18.4
208-240	at 208	3	50/60	3 Wire plus ground	38.5/ph	13.8
	at 240			AWG 6	44.0/ph	18.3
380-415	at 380	3	50/60	4 Wire plus ground	21.5/ph	14.2
	at 415			AWG 10	25.6/ph	18.4
440-480	at 440	3*	50/60	3 Wire plus ground	20.0/ph	15.4
	at 480			AWG 8	22.0/ph	18.4

* ELECTRICAL SERVICE CHARGE APPLIES

WEIGHT		CAPACITY	
NET	404 lb (183 kg)	FULL-SIZE PANS:	20" x 12" x 2-1/2" Ten (10)
SHIP	528 lb (239 kg)	GN 1/1:	530 x 325 x 65mm Ten (10)
		HALF-SIZE SHEET PANS:*	18" x 13" x 1" Ten (10)
CRATE	49" x 47" x 37" EST.	ON WIRE SHELVES ONLY	
DIMENSIONS: (1245 x 1194 x 940mm)		120 lb (54 kg) MAXIMUM	
		VOLUME MAXIMUM: 75 QUARTS (95 LITERS)	

* ADDITIONAL WIRE SHELVES REQUIRED FOR MAXIMUM CAPACITY

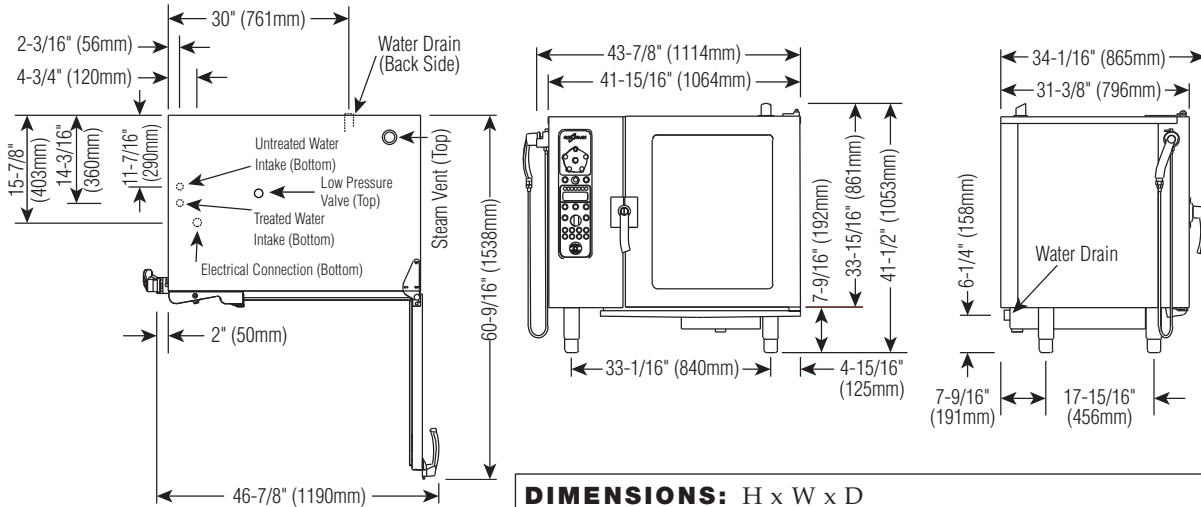

DIMENSIONS: H x W x D	
EXTERIOR:	41-1/2" x 43-7/8" x 34-1/16" (1053mm x 1114mm x 865mm)
EXTERIOR WITH RETRACTABLE DOOR:	41-1/2" x 47-7/8" x 34-1/16" (1053mm x 1216mm x 865mm)
INTERIOR:	27" x 23-1/2" x 21-1/16" (685mm x 597mm x 535mm)

INSTALLATION REQUIREMENTS
 Oven must be installed level.
 Hood installation is required.
 Water supply shut-off valve and back-flow preventer.

WATER REQUIREMENTS
TWO (2) COLD WATER INLETS - DRINKING QUALITY
 ONE (1) TREATED WATER INLET: 3/4" NPT*
 ONE (1) UNTREATED WATER INLET: 3/4" NPT*
 LINE PRESSURE: 30 to 90 psi 2.8 to 6.2 bar
WATER DRAIN: 1-1/2" CONNECTION WITH AIR GAP
 * Can manifold off of one 3/4" line.

WATER QUALITY MINIMUM STANDARDS
 USING A WATER SUPPLY NOT MEETING ALTO-SHAAM'S MINIMUM WATER QUALITY STANDARDS WILL VOID THIS WARRANTY. It is the responsibility of the purchaser to ensure that incoming water supply is compliant with the specifications listed through adequate treatment measures. Installation of the CombiGuard™ Water Filtration System is recommended, but this system may not address all water quality issues present.

Contaminant	Inlet Water Requirements (untreated water)
Free Chlorine	Less than 0.1 ppm (mg/L)
Hardness	Less than 3 gpg (52 ppm)
Chloride	Less than 30 ppm (mg/L)
pH	7.0 to 8.5
Alkalinity	Less than 50 ppm (mg/L)
Silica	Less than 12 ppm (mg/L)
Total Dissolved Solids (tds)	Less than 60 ppm

CLEARANCE REQUIREMENTS
 LEFT: 6" (152mm) PLUS SERVICE ACCESS: 18" (457mm) RECOMMENDED 20" (508mm) FROM HEAT PRODUCING EQUIPMENT
 RIGHT: 4" (102mm) TOP: 20" (508mm) FOR AIR MOVEMENT
 BACK: 4" (102mm) BOTTOM: 5-1/8" (130mm) FOR LEGS
 COUNTER-TOP INSTALLATIONS MUST MAINTAIN 4" (102mm) MINIMUM CLEARANCE FROM COUNTER SURFACE.

ELECTRICAL					10•10esi		10•10esi/sk	
	VOLTAGE	PHASE	CYCLE/HZ	AWG	AMPS	kW	AMPS	kW
208-240	at 208	1*	50/60	2 Wire plus ground	67.0	13.9	69.2	14.4
	at 240			AWG 3	77.0	18.4	79.0	18.9
208-240	at 208	3	50/60	3 Wire plus ground	38.6/ph	13.9	40.0/ph	14.4
	at 240			AWG 6	44.3/ph	18.4	45.5/ph	18.9
380-415	at 380	3	50/60	4 Wire plus ground	21.1/ph	13.9	22.0/ph	14.4
	at 415			AWG 10	25.6/ph	18.4	26.3/ph	18.9
440-480	at 440	3*	50/60	3 Wire plus ground	20.0/ph	15.4	21.0/ph	15.9
	at 480			AWG 8	22.0/ph	18.4	23.0/ph	18.9

* ELECTRICAL SERVICE CHARGE APPLIES

WEIGHT			CAPACITY	
NET	377 lb (171 kg)		FULL-SIZE PANS: 20" x 12" x 2-1/2"	Ten (10)
			GN 1/1: 530 x 325 x 65mm	Ten (10)
SHIP	501 lb (227 kg)		HALF-SIZE SHEET PANS:* 18" x 13" x 1"	Ten (10)
			ON WIRE SHELVES ONLY	
CRATE	49" x 47" x 37" EST.		120 lb (54 kg) MAXIMUM	
DIMENSIONS:	(1245 x 1194 x 940mm)		VOLUME MAXIMUM: 75 QUARTS (95 LITERS)	

*ADDITIONAL WIRE SHELVES REQUIRED FOR MAXIMUM CAPACITY

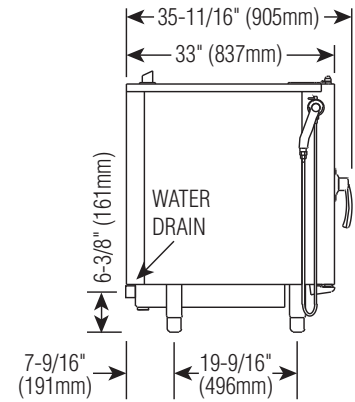
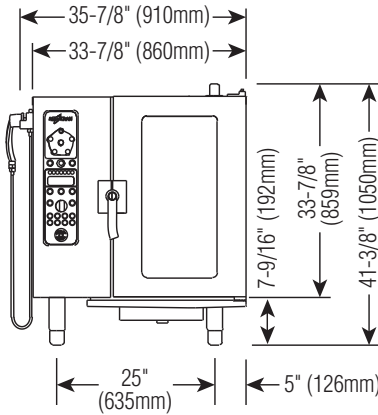
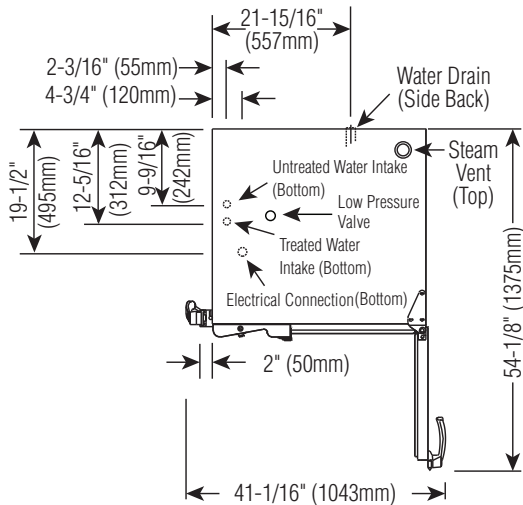

DIMENSIONS: H x W x D

EXTERIOR:	41-3/8" x 35-7/8" x 35-11/16" (1050mm x 910mm x 905mm)
EXTERIOR WITH RETRACTABLE DOOR:	41-3/8" x 39-7/8" x 35-11/16" (1050mm x 1012mm x 905mm)
INTERIOR:	27" x 13-1/4" x 26-1/4" (685mm x 387mm x 665mm)

INSTALLATION REQUIREMENTS

Oven must be installed level.
 Hood installation is required.
 Water supply shut-off valve and back-flow preventer.

WATER REQUIREMENTS

TWO (2) COLD WATER INLETS - DRINKING QUALITY
ONE (1) TREATED WATER INLET: 3/4" NPT*
ONE (1) UNTREATED WATER INLET: 3/4" NPT*
LINE PRESSURE: 30 to 90 psi 2.8 to 6.2 bar
WATER DRAIN: 1-1/2" CONNECTION WITH AIR GAP
 * Can manifold off of one 3/4" line.

CLEARANCE REQUIREMENTS

LEFT: 6" (152mm) **PLUS SERVICE ACCESS: 18" (457mm) RECOMMENDED**
20" (508mm) FROM HEAT PRODUCING EQUIPMENT
RIGHT: 4" (102mm) **TOP:** 20" (508mm) FOR AIR MOVEMENT
BACK: 4" (102mm) **BOTTOM:** 5-1/8" (130mm) FOR LEGS
 COUNTER-TOP INSTALLATIONS MUST MAINTAIN 4" (102mm) MINIMUM CLEARANCE FROM COUNTER SURFACE.

WATER QUALITY MINIMUM STANDARDS

USING A WATER SUPPLY NOT MEETING ALTO-SHAAM'S MINIMUM WATER QUALITY STANDARDS WILL VOID THIS WARRANTY. It is the responsibility of the purchaser to ensure that incoming water supply is compliant with the specifications listed through adequate treatment measures. Installation of the CombiGuard™ Water Filtration System is recommended, but this system may not address all water quality issues present.

Contaminant	Inlet Water Requirements (untreated water)
Free Chlorine	Less than 0.1 ppm (mg/L)
Hardness	Less than 3 gpg (52 ppm)
Chloride	Less than 30 ppm (mg/L)
pH	7.0 to 8.5
Alkalinity	Less than 50 ppm (mg/L)
Silica	Less than 12 ppm (mg/L)
Total Dissolved Solids (tds)	Less than 60 ppm

ELECTRICAL

VOLTAGE	PHASE	CYCLE/HZ	AWG	10•10 ^{ESiN}		10•10 ^{ESiN} /sk	
				AMPS	kW	AMPS	kW
208-240	1*	50/60	2 Wire plus ground AWG 3	67.0	13.9	69.2	14.4
				77.0	18.4	79.0	18.9
208-240	3	50/60	3 Wire plus ground AWG 6	38.6/ph	13.9	40.0/ph	14.4
				44.3/ph	18.4	45.5/ph	18.9
380-415	3	50/60	4 Wire plus ground AWG 10	21.1/ph	13.9	22.0/ph	14.4
				25.6/ph	18.4	26.3/ph	18.9
440-480	3*	50/60	3 Wire plus ground AWG 8	20.0/ph	15.4	21.0/ph	15.9
				22.0/ph	18.4	23.0/ph	18.9

* ELECTRICAL SERVICE CHARGE APPLIES

WEIGHT

NET 385 lb EST. (175 kg) EST.
SHIP 500 lb EST. (227 kg) EST.
CRATE 49" x 44" x 40" EST.
DIMENSIONS: (1245 x 1118 x 1016mm)

CAPACITY

FULL-SIZE PANS: 20" x 12" x 2-1/2"	Ten (10)	Eight (8)
GN 1/1: 530 x 325 x 65mm	Ten (10)	Eight (8)
HALF-SIZE SHEET PANS:* 18" x 13" x 1" ON WIRE SHELVES ONLY	Ten (10)	Nine (9)
120 lb (54 kg) MAXIMUM		
VOLUME MAXIMUM: 75 QUARTS (95 LITERS)		

* ADDITIONAL WIRE SHELVES REQUIRED FOR MAXIMUM CAPACITY

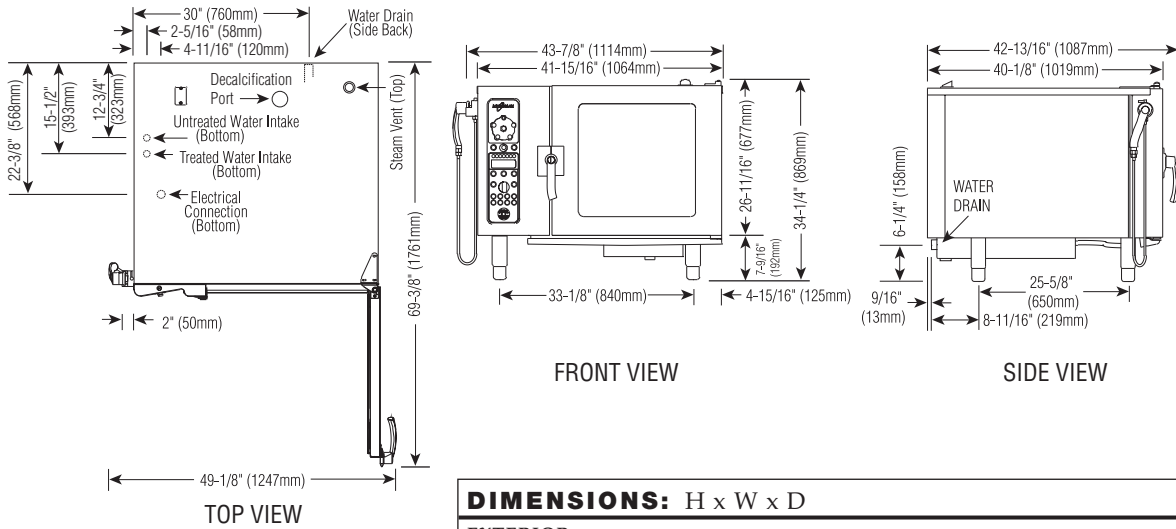

DIMENSIONS: H x W x D	
EXTERIOR:	34-1/4" x 43-7/8" x 42-13/16" (869mm x 1114mm x 1087mm)
EXTERIOR WITH RETRACTABLE DOOR:	34-1/4" x 47-7/8" x 42-13/16" (869mm x 1216mm x 1087mm)
INTERIOR:	20-5/16" x 23-1/2" x 28-7/16" (515mm x 596mm x 722mm)

INSTALLATION REQUIREMENTS
 Oven must be installed level.
 Hood installation is required.
 Water supply shut-off valve and back-flow preventer.

WATER REQUIREMENTS
TWO (2) COLD WATER INLETS - DRINKING QUALITY
ONE (1) TREATED WATER INLET: 3/4" NPT*
ONE (1) UNTREATED WATER INLET: 3/4" NPT*
LINE PRESSURE: 30 to 90 psi 2.8 to 6.2 bar
WATER DRAIN: 1-1/2" CONNECTION WITH AIR GAP
 * Can manifold off of one 3/4" line.

WATER QUALITY MINIMUM STANDARDS	
USING A WATER SUPPLY NOT MEETING ALTO-SHAAM'S MINIMUM WATER QUALITY STANDARDS WILL VOID THIS WARRANTY. It is the responsibility of the purchaser to ensure that incoming water supply is compliant with the specifications listed through adequate treatment measures. Installation of the CombiGuard™ Water Filtration System is recommended, but this system may not address all water quality issues present.	
Contaminant	Inlet Water Requirements (untreated water)
Free Chlorine	Less than 0.1 ppm (mg/L)
Hardness	Less than 3 gpg (52 ppm)
Chloride	Less than 30 ppm (mg/L)
pH	7.0 to 8.5
Alkalinity	Less than 50 ppm (mg/L)
Silica	Less than 12 ppm (mg/L)
Total Dissolved Solids (tds)	Less than 60 ppm

CLEARANCE REQUIREMENTS
LEFT: 6" (152mm) **PLUS SERVICE ACCESS: 18" (457mm) RECOMMENDED 20" (508mm) FROM HEAT PRODUCING EQUIPMENT**
RIGHT: 4" (102mm) **TOP:** 20" (508mm) FOR AIR MOVEMENT
BACK: 4" (102mm) **BOTTOM:** 5-1/8" (130mm) FOR LEGS
 COUNTER-TOP INSTALLATIONS MUST MAINTAIN 4" (102mm) MINIMUM CLEARANCE FROM COUNTER SURFACE.

ELECTRICAL						
	VOLTAGE	PHASE	CYCLE/HZ	AWG	AMPS	kW
208-240	at 208	1*	50/60	2 Wire plus ground	67.0	13.9
	at 240			AWG 3	77.0	18.4
208-240	at 208	3	50/60	3 Wire plus ground	38.5/ph	13.8
	at 240			AWG 6	44.0/ph	18.3
380-415	at 380	3	50/60	4 Wire plus ground	21.5/ph	14.2
	at 415			AWG 10	25.6/ph	18.4
440-480	at 440	3*	50/60	3 Wire plus ground	20.0/ph	15.4
	at 480			AWG 8	22.0/ph	18.4

* ELECTRICAL SERVICE CHARGE APPLIES

WEIGHT		CAPACITY		
NET	416 lb (189 kg)	FULL-SIZE PANS:	20" x 12" x 2-1/2"	Fourteen (14)
		GN 1/1:	530 x 325 x 65mm	Fourteen (14)
SHIP	540 lb (245 kg)	GN 2/1:	650 x 530 x 65mm	Seven (7)
		FULL-SIZE SHEET PANS:* ON WIRE SHELVES ONLY	18" x 26" x 1"	Seven (7)
CRATE	52" x 50" x 46" EST.	168 lb (76 kg) MAXIMUM		
DIMENSIONS: (1321 x 1270 x 1168mm)		VOLUME MAXIMUM: 105 QUARTS (133 LITERS)		

* ADDITIONAL WIRE SHELVES REQUIRED FOR MAXIMUM CAPACITY

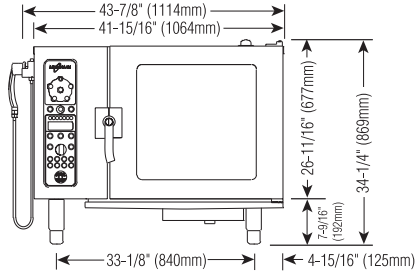
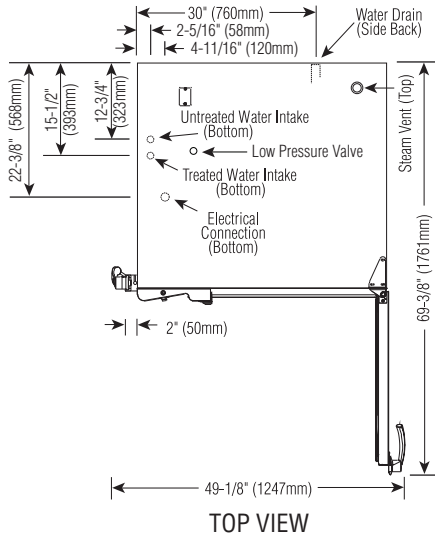

FRONT VIEW

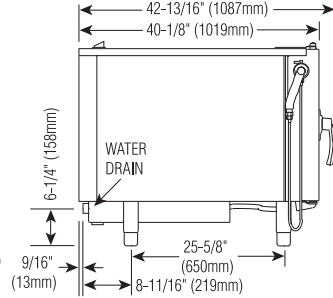

SIDE VIEW

DIMENSIONS: H x W x D

EXTERIOR:	34-1/4" x 43-7/8" x 42-13/16" (869mm x 1114mm x 1087mm)
EXTERIOR WITH RETRACTABLE DOOR:	34-1/4" x 47-7/8" x 42-13/16" (869mm x 1216mm x 1087mm)
INTERIOR:	20-5/16" x 23-1/2" x 28-7/16" (515mm x 596mm x 722mm)

INSTALLATION REQUIREMENTS
Oven must be installed level. Hood installation is required. Water supply shut-off valve and back-flow preventer.

WATER REQUIREMENTS
TWO (2) COLD WATER INLETS - DRINKING QUALITY
ONE (1) TREATED WATER INLET: 3/4" NPT*
ONE (1) UNTREATED WATER INLET: 3/4" NPT*
LINE PRESSURE: 30 to 90 psi 2.8 to 6.2 bar
WATER DRAIN: 1-1/2" CONNECTION WITH AIR GAP
* Can manifold off of one 3/4" line.

WATER QUALITY MINIMUM STANDARDS																
USING A WATER SUPPLY NOT MEETING ALTO-SHAAM'S MINIMUM WATER QUALITY STANDARDS WILL VOID THIS WARRANTY. It is the responsibility of the purchaser to ensure that incoming water supply is compliant with the specifications listed through adequate treatment measures. Installation of the CombiGuard™ Water Filtration System is recommended, but this system may not address all water quality issues present.																
<table border="1"> <tr> <th>Contaminant</th> <th>Inlet Water Requirements (untreated water)</th> </tr> <tr> <td>Free Chlorine</td> <td>Less than 0.1 ppm (mg/L)</td> </tr> <tr> <td>Hardness</td> <td>Less than 3 gpg (52 ppm)</td> </tr> <tr> <td>Chloride</td> <td>Less than 30 ppm (mg/L)</td> </tr> <tr> <td>pH</td> <td>7.0 to 8.5</td> </tr> <tr> <td>Alkalinity</td> <td>Less than 50 ppm (mg/L)</td> </tr> <tr> <td>Silica</td> <td>Less than 12 ppm (mg/L)</td> </tr> <tr> <td>Total Dissolved Solids (tds)</td> <td>Less than 60 ppm</td> </tr> </table>	Contaminant	Inlet Water Requirements (untreated water)	Free Chlorine	Less than 0.1 ppm (mg/L)	Hardness	Less than 3 gpg (52 ppm)	Chloride	Less than 30 ppm (mg/L)	pH	7.0 to 8.5	Alkalinity	Less than 50 ppm (mg/L)	Silica	Less than 12 ppm (mg/L)	Total Dissolved Solids (tds)	Less than 60 ppm
Contaminant	Inlet Water Requirements (untreated water)															
Free Chlorine	Less than 0.1 ppm (mg/L)															
Hardness	Less than 3 gpg (52 ppm)															
Chloride	Less than 30 ppm (mg/L)															
pH	7.0 to 8.5															
Alkalinity	Less than 50 ppm (mg/L)															
Silica	Less than 12 ppm (mg/L)															
Total Dissolved Solids (tds)	Less than 60 ppm															

CLEARANCE REQUIREMENTS
LEFT: 6" (152mm) PLUS SERVICE ACCESS: 18" (457mm) RECOMMENDED 20" (508mm) FROM HEAT PRODUCING EQUIPMENT
RIGHT: 4" (102mm) TOP: 20" (508mm) FOR AIR MOVEMENT
BACK: 4" (102mm) BOTTOM: 5-1/8" (130mm) FOR LEGS
COUNTER-TOP INSTALLATIONS MUST MAINTAIN 4" (102mm) MINIMUM CLEARANCE FROM COUNTER SURFACE.

ELECTRICAL				7•14 Esi		7•14 Esi/sk		
	VOLTAGE	PHASE	CYCLE/HZ	AWG	AMPS	kW	AMPS	kW
208-240	at 208	1*	50/60	2 Wire plus ground	67.0	13.9	69.2	14.4
	at 240			AWG 3	77.0	18.4	79.0	18.9
208-240	at 208	3	50/60	3 Wire plus ground	38.6/ph	13.9	40.0/ph	14.4
	at 240			AWG 6	44.3/ph	18.4	45.5/ph	18.9
380-415	at 380	3	50/60	4 Wire plus ground	21.1/ph	13.9	22.0/ph	14.4
	at 415			AWG 10	25.6/ph	18.4	26.3/ph	18.9
440-480	at 440	3*	50/60	3 Wire plus ground	20.0/ph	15.4	21.0/ph	15.9
	at 480			AWG 8	22.0/ph	18.4	23.0/ph	18.9
* ELECTRICAL SERVICE CHARGE APPLIES								

WEIGHT	CAPACITY
NET 436 lb (198 kg)	FULL-SIZE PANS: 20" x 12" x 2-1/2" GN 1/1: 530 x 325 x 65mm GN 2/1: 650 x 530 x 65mm
SHIP 560 lb (254 kg)	FULL-SIZE SHEET PANS:* 18" x 26" x 1" ON WIRE SHELVES ONLY
CRATE 42" x 50" x 46" EST.	168 lb (76 kg) MAXIMUM
DIMENSIONS: (1067 x 1270 x 1168mm)	VOLUME MAXIMUM: 105 QUARTS (133 LITERS)

* ADDITIONAL WIRE SHELVES REQUIRED FOR MAXIMUM CAPACITY

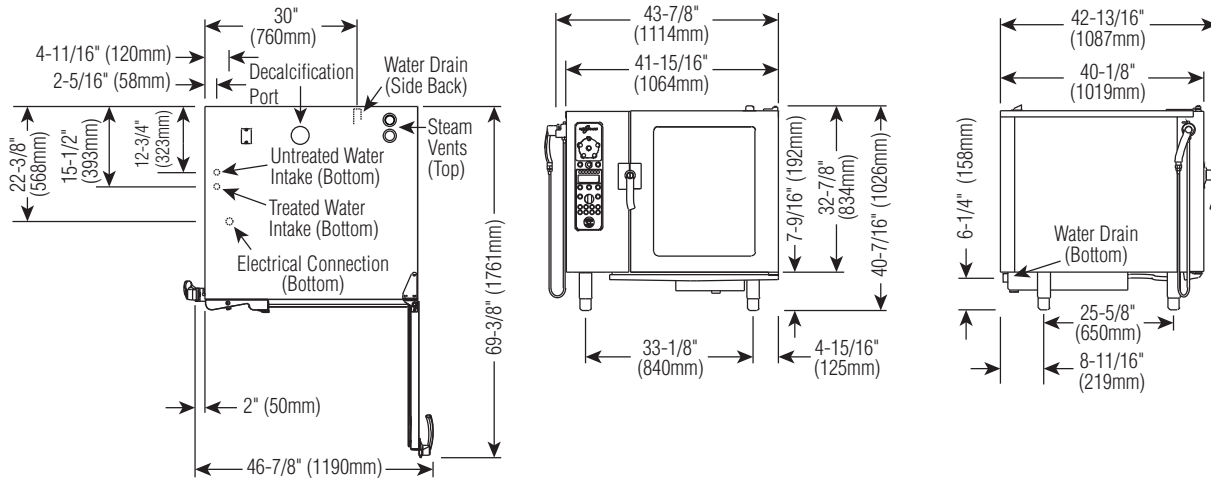

DIMENSIONS: H x W x D	
EXTERIOR:	40-7/16" x 43-7/8" x 42-13/16" (1026mm x 1114mm x 1087mm)
EXTERIOR WITH RETRACTABLE DOOR:	40-7/16" x 47-7/8" x 42-13/16" (1026mm x 1216mm x 1087mm)
INTERIOR:	30-3/4" x 23-1/2" x 28-7/16" (781mm x 596mm x 722mm)

INSTALLATION REQUIREMENTS

Oven must be installed level.
Hood installation is required.
Water supply shut-off valve and back-flow preventer.

WATER REQUIREMENTS

TWO (2) COLD WATER INLETS - DRINKING QUALITY

ONE (1) TREATED WATER INLET: 3/4" NPT*
ONE (1) UNTREATED WATER INLET: 3/4" NPT*
LINE PRESSURE: 30 to 90 psi 2.8 to 6.2 bar

WATER DRAIN: 1-1/2" CONNECTION WITH AIR GAP

* Can manifold off of one 3/4" line.

WATER QUALITY MINIMUM STANDARDS

USING A WATER SUPPLY NOT MEETING ALTO-SHAAM'S MINIMUM WATER QUALITY STANDARDS WILL VOID THIS WARRANTY. It is the responsibility of the purchaser to ensure that incoming water supply is compliant with the specifications listed through adequate treatment measures. Installation of the CombiGuard™ Water Filtration System is recommended, but this system may not address all water quality issues present.

Contaminant	Inlet Water Requirements (untreated water)
Free Chlorine	Less than 0.1 ppm (mg/L)
Hardness	Less than 3 gpg (52 ppm)
Chloride	Less than 30 ppm (mg/L)
pH	7.0 to 8.5
Alkalinity	Less than 50 ppm (mg/L)
Silica	Less than 12 ppm (mg/L)
Total Dissolved Solids (tds)	Less than 60 ppm

CLEARANCE REQUIREMENTS

LEFT: 6" (152mm) **PLUS SERVICE ACCESS:** 18" (457mm) **RECOMMENDED**
20" (508mm) **FROM HEAT PRODUCING EQUIPMENT**

RIGHT: 4" (102mm) **TOP:** 20" (508mm) **FOR AIR MOVEMENT**

BACK: 4" (102mm) **BOTTOM:** 5-1/8" (130mm) **FOR LEGS**

COUNTER-TOP INSTALLATIONS MUST MAINTAIN 4" (102mm) MINIMUM CLEARANCE FROM COUNTER SURFACE.

ELECTRICAL

	VOLTAGE	PHASE	CYCLE/HZ	AWG	AMPS	kW
208-240	at 208	3	50/60	3 Wire plus ground	61.3/ph	22.0
	at 240			AWG 2	70.0/ph	29.2
380-415	at 380	3	50/60	4 Wire plus ground	33.5/ph	22.0
	at 415			AWG 6	40.7/ph	29.2
440-480	at 440	3*	50/60	3 Wire plus ground	36.0/ph	27.2
	at 480			AWG 6	43.5/ph	36.1

* ELECTRICAL SERVICE CHARGE APPLIES

WEIGHT		CAPACITY	
NET	522 lb (237 kg)	FULL-SIZE PANS:	20" x 12" x 2-1/2"
		GN 1/1:	530 x 325 x 65mm
SHIP	646 lb (293 kg)	GN 2/1:	650 x 530 x 65mm
		FULL-SIZE SHEET PANS:*	18" x 26" x 1"
CRATE	46" x 51" x 46" EST.	ON WIRE SHELVES ONLY	
DIMENSIONS: (1168 x 1295 x 1168mm)		240 lb (109 kg) MAXIMUM	
		VOLUME MAXIMUM: 150 QUARTS (190 LITERS)	

* ADDITIONAL WIRE SHELVES REQUIRED FOR MAXIMUM CAPACITY

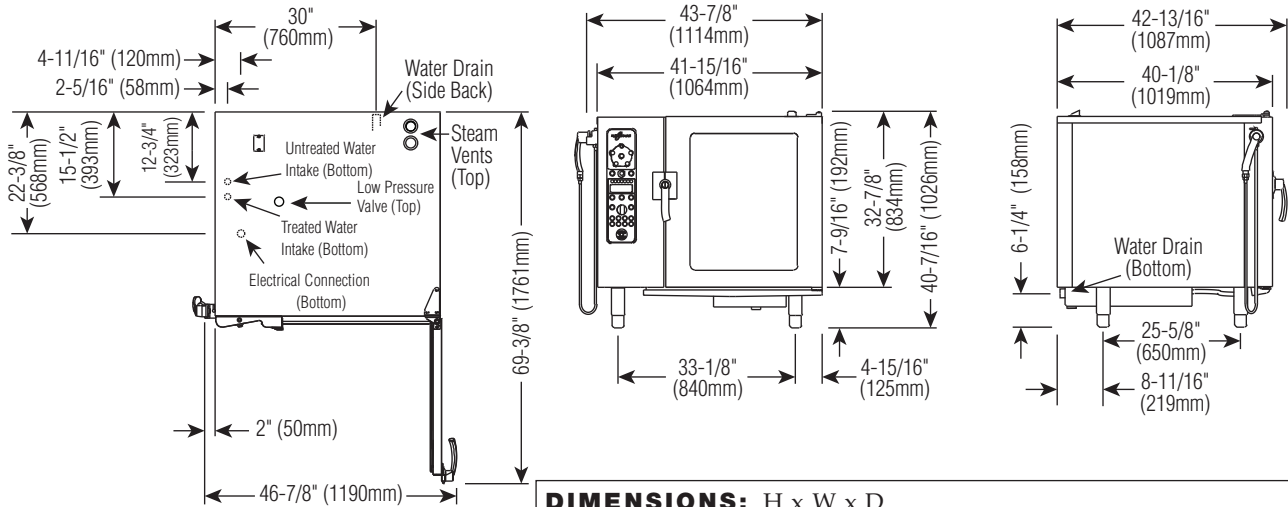

DIMENSIONS: H x W x D	
EXTERIOR:	40-7/16" x 43-7/8" x 42-13/16" (1026mm x 1114mm x 1087mm)
EXTERIOR WITH RETRACTABLE DOOR:	40-7/16" x 47-7/8" x 42-13/16" (1026mm x 1216mm x 1087mm)
INTERIOR:	30-3/4" x 23-1/2" x 28-7/16" (781mm x 596mm x 722mm)

INSTALLATION REQUIREMENTS
Oven must be installed level.
Hood installation is required.
Water supply shut-off valve and back-flow preventer.

WATER REQUIREMENTS
TWO (2) COLD WATER INLETS - DRINKING QUALITY
ONE (1) TREATED WATER INLET: 3/4" NPT*
ONE (1) UNTREATED WATER INLET: 3/4" NPT*
LINE PRESSURE: 30 to 90 psi 2.8 to 6.2 bar
WATER DRAIN: 1-1/2" CONNECTION WITH AIR GAP
* Can manifold off of one 3/4" line.

WATER QUALITY MINIMUM STANDARDS
USING A WATER SUPPLY NOT MEETING ALTO-SHAAM'S MINIMUM WATER QUALITY STANDARDS WILL VOID THIS WARRANTY. It is the responsibility of the purchaser to ensure that incoming water supply is compliant with the specifications listed through adequate treatment measures. Installation of the CombiGuard™ Water Filtration System is recommended, but this system may not address all water quality issues present.

Contaminant	Inlet Water Requirements (untreated water)
Free Chlorine	Less than 0.1 ppm (mg/L)
Hardness	Less than 3 gpg (52 ppm)
Chloride	Less than 30 ppm (mg/L)
pH	7.0 to 8.5
Alkalinity	Less than 50 ppm (mg/L)
Silica	Less than 12 ppm (mg/L)
Total Dissolved Solids (tds)	Less than 60 ppm

CLEARANCE REQUIREMENTS
LEFT: 6" (152mm) PLUS SERVICE ACCESS: 18" (457mm) RECOMMENDED 20" (508mm) FROM HEAT PRODUCING EQUIPMENT
RIGHT: 4" (102mm) TOP: 20" (508mm) FOR AIR MOVEMENT
BACK: 4" (102mm) BOTTOM: 5-1/8" (130mm) FOR LEGS
COUNTER-TOP INSTALLATIONS MUST MAINTAIN 4" (102mm) MINIMUM CLEARANCE FROM COUNTER SURFACE.

ELECTRICAL					10•18 Esi		10•18 Esi/sk	
	VOLTAGE	PHASE	CYCLE/HZ	AWG	AMPS	kW	AMPS	kW
208-240	at 208	3	50/60	3 Wire plus ground	61.1/ph	22.0	62.5/ph	22.5
	at 240			AWG 2	70.3/ph	29.2	71.5/ph	29.7
380-415	at 380	3	50/60	4 Wire plus ground	33.5/ph	22.0	34.2/ph	22.5
	at 415			AWG 8	40.7/ph	29.2	41.4/ph	29.7
440-480	at 440	3*	50/60	3 Wire plus ground	35.7/ph	27.2	36.4/ph	27.7
	at 480			AWG 8	43.5/ph	36.1	44.0/ph	36.6

* ELECTRICAL SERVICE CHARGE APPLIES

WEIGHT			CAPACITY	
NET	520 lb	(236 kg)	FULL-SIZE PANS: 20" x 12" x 2-1/2"	Twenty (20)
SHIP	640 lb	(290 kg)	GN 1/1: 530 x 325 x 65mm	Twenty (20)
			GN 2/1: 650 x 530 x 65mm	Ten (10)
CRATE	46" x 51" x 46" EST.		FULL-SIZE SHEET PANS:* 18" x 26" x 1"	Ten (10)
DIMENSIONS: (1168 x 1295 x 1168mm)			ON WIRE SHELVES ONLY	
240 lb (109 kg) MAXIMUM				
VOLUME MAXIMUM: 150 QUARTS (190 LITERS)				

* ADDITIONAL WIRE SHELVES REQUIRED FOR MAXIMUM CAPACITY

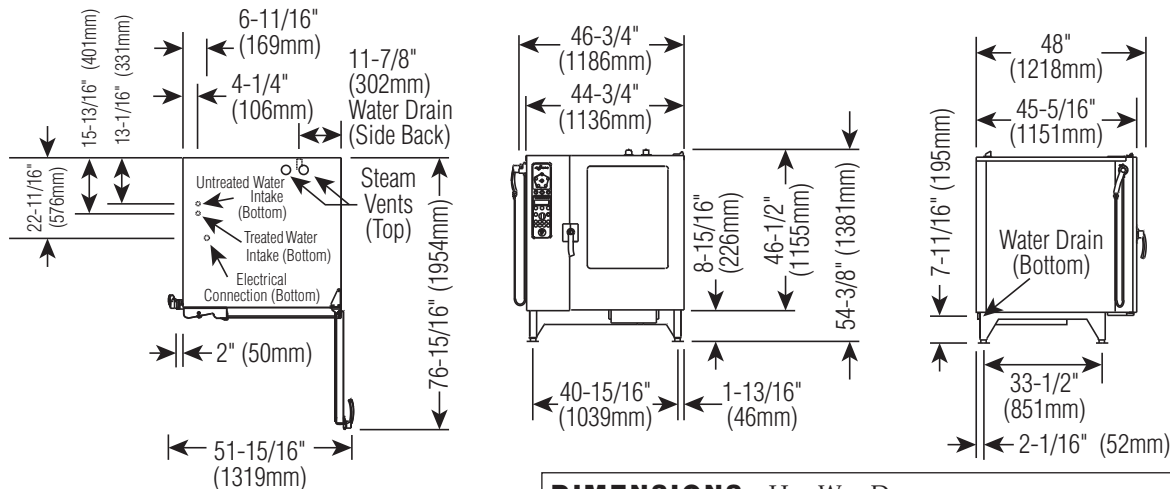

DIMENSIONS: H x W x D	
EXTERIOR:	54-3/8" x 46-3/4" x 48" (1381mm x 1186mm x 1218mm)
EXTERIOR WITH RETRACTABLE DOOR:	54-3/8" x 50-3/4" x 48" (1381mm x 1288mm x 1218mm)
INTERIOR:	38-11/16" x 26-1/4" x 32-11/16" (983mm x 667mm x 830mm)

INSTALLATION REQUIREMENTS

Oven must be installed level.
Hood installation is required.
Water supply shut-off valve and back-flow preventer.

WATER REQUIREMENTS

TWO (2) COLD WATER INLETS - DRINKING QUALITY

ONE (1) TREATED WATER INLET: 3/4" NPT*
ONE (1) UNTREATED WATER INLET: 3/4" NPT*
LINE PRESSURE: 30 to 90 psi 2.8 to 6.2 bar

WATER DRAIN: 1-1/2" CONNECTION WITH AIR GAP
* Can manifold off of one 3/4" line.

WATER QUALITY MINIMUM STANDARDS

USING A WATER SUPPLY NOT MEETING ALTO-SHAAM'S MINIMUM WATER QUALITY STANDARDS WILL VOID THIS WARRANTY. It is the responsibility of the purchaser to ensure that incoming water supply is compliant with the specifications listed through adequate treatment measures. Installation of the CombiGuard™ Water Filtration System is recommended, but this system may not address all water quality issues present.

Contaminant	Inlet Water Requirements (untreated water)
Free Chlorine	Less than 0.1 ppm (mg/L)
Hardness	Less than 3 gpg (52 ppm)
Chloride	Less than 30 ppm (mg/L)
pH	7.0 to 8.5
Alkalinity	Less than 50 ppm (mg/L)
Silica	Less than 12 ppm (mg/L)
Total Dissolved Solids (tds)	Less than 60 ppm

CLEARANCE REQUIREMENTS

LEFT: 6" (152mm) PLUS SERVICE ACCESS: 18" (457mm) RECOMMENDED
20" (508mm) FROM HEAT PRODUCING EQUIPMENT

RIGHT: 4" (102mm) TOP: 20" (508mm) FOR AIR MOVEMENT

BACK: 4" (102mm) BOTTOM: 5-1/8" (130mm) FOR LEGS

ELECTRICAL

	VOLTAGE	PHASE	CYCLE/HZ	AWG	AMPS	kW
208-240	at 208	3	50/60	3 Wire plus ground	75.6/ph	27.2
	at 240			AWG 2	87.0/ph	36.1
380-415	at 380	3	50/60	4 Wire plus ground	41.4/ph	27.2
	at 415			AWG 6	50.0/ph	35.7
440-480	at 440	3*	50/60	3 Wire plus ground	36.0/ph	27.2
	at 480			AWG 6	43.5/ph	36.1

* ELECTRICAL SERVICE CHARGE APPLIES

WEIGHT		CAPACITY	
NET	747 lb (339 kg)	FULL-SIZE PANS:	20" x 12" x 2-1/2" Twenty-four (24)
SHIP	1070 lb (485 kg)	GN 1/1:	530 x 325 x 65mm Twenty-four (24)
		GN 2/1:	650 x 530 x 65mm Twelve (12)
CRATE	61" x 58" x 53"	FULL-SIZE SHEET PANS:*	18" x 26" x 1" Twelve (12)
DIMENSIONS: (1549 x 1473 x 1346mm)		ON WIRE SHELVES ONLY	
		288 lb (131 kg) MAXIMUM	
		VOLUME MAXIMUM: 180 QUARTS (228 LITERS)	

*ADDITIONAL WIRE SHELVES REQUIRED FOR MAXIMUM CAPACITY

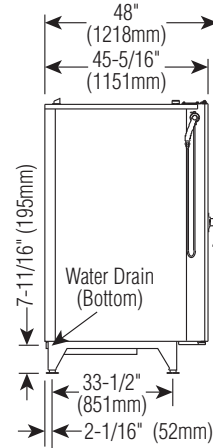
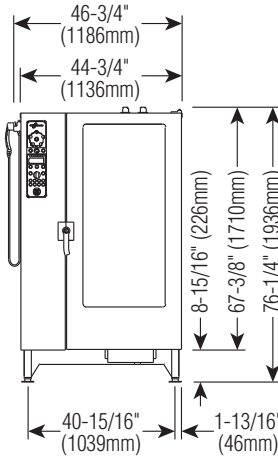
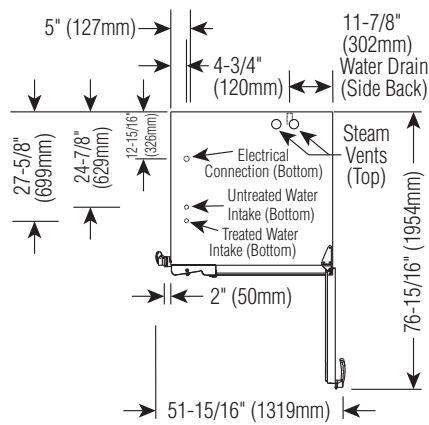
DIMENSIONS: H x W x D
EXTERIOR:

76-1/4" x 46-3/4" x 48" (1936mm x 1186mm x 1218mm)

EXTERIOR WITH RETRACTABLE DOOR:

76-1/4" x 50-3/4" x 48" (1936mm x 1288mm x 1218mm)

INTERIOR:

60-1/4" x 26-1/4" x 32-11/16" (1530mm x 667mm x 830mm)

INSTALLATION REQUIREMENTS

Oven must be installed level.
Hood installation is required.
Water supply shut-off valve and back-flow preventer.

WATER REQUIREMENTS
TWO (2) COLD WATER INLETS - DRINKING QUALITY

ONE (1) TREATED WATER INLET: 3/4" NPT*
ONE (1) UNTREATED WATER INLET: 3/4" NPT*
LINE PRESSURE: 30 to 90 psi 2.8 to 6.2 bar

WATER DRAIN: 1-1/2" CONNECTION WITH AIR GAP

* Can manifold off of one 3/4" line.

CLEARANCE REQUIREMENTS

LEFT: 6" (152mm) PLUS SERVICE ACCESS: 18" (457mm) RECOMMENDED
20" (508mm) FROM HEAT PRODUCING EQUIPMENT

RIGHT: 4" (102mm) TOP: 20" (508mm) FOR AIR MOVEMENT

BACK: 4" (102mm) BOTTOM: 5-1/8" (130mm) FOR LEGS

WATER QUALITY MINIMUM STANDARDS

USING A WATER SUPPLY NOT MEETING ALTO-SHAAM'S MINIMUM WATER QUALITY STANDARDS WILL VOID THIS WARRANTY. It is the responsibility of the purchaser to ensure that incoming water supply is compliant with the specifications listed through adequate treatment measures. Installation of the CombiGuard™ Water Filtration System is recommended, but this system may not address all water quality issues present.

Contaminant	Inlet Water Requirements (untreated water)
Free Chlorine	Less than 0.1 ppm (mg/L)
Hardness	Less than 3 gpg (52 ppm)
Chloride	Less than 30 ppm (mg/L)
pH	7.0 to 8.5
Alkalinity	Less than 50 ppm (mg/L)
Silica	Less than 12 ppm (mg/L)
Total Dissolved Solids (tds)	Less than 60 ppm

ELECTRICAL

	VOLTAGE	PHASE	CYCLE/HZ	AWG	AMPS	kW
208-240	at 208	3	50/60	3 Wire plus ground	151.2/ph	54.4
	at 240			AWG 4	173.4/ph	72.2
380-415	at 380	3	50/60	4 Wire plus ground	83.0/ph	54.4
	at 415			AWG 2	101.0/ph	72.2
440-480	at 440	3*	50/60	3 Wire plus ground	71.5/ph	54.4
	at 480			AWG 2	87.0/ph	72.2

* ELECTRICAL SERVICE CHARGE APPLIES

WEIGHT

NET	958 lb EST.	(435 kg) EST.
SHIP	1340 lb	(608 kg)
CRATE	83" x 54" x 53"	
DIMENSIONS:	(2108 x 1372 x 1346mm)	

CAPACITY

FULL-SIZE PANS:	20" x 12" x 2-1/2"	Forty (40)
GN 1/1:	530 x 325 x 65mm	Forty (40)
GN 2/1:	650 x 530 x 65mm	Twenty (20)
FULL-SIZE SHEET PANS:*	18" x 26" x 1"	Twenty (20)
ON WIRE SHELVES ONLY		
480 lb (218 kg) MAXIMUM		
VOLUME MAXIMUM: 300 QUARTS (380 LITERS)		

*ADDITIONAL WIRE SHELVES REQUIRED FOR MAXIMUM CAPACITY

DANGER	
	<p>IMPROPER INSTALLATION, ALTERATION, ADJUSTMENT, SERVICE, OR MAINTENANCE COULD RESULT IN SEVERE INJURY, DEATH OR CAUSE PROPERTY DAMAGE.</p> <p>READ THE INSTALLATION, OPERATING AND MAINTENANCE INSTRUCTIONS THOROUGHLY BEFORE INSTALLING OR SERVICING THIS EQUIPMENT.</p>

DANGER	
	<p>AVERTISSEMENT : UNE INSTALLATION, UN AJUSTEMENT, UNE ALTÉRATION, UN SERVICE OU UN ENTRETIEN NON CONFORME AUX NORMES PEUT CAUSER DES DOMMAGES À LA PROPRIÉTÉ, DES BLESSURES OU LA MORT.</p> <p>LIRE ATTENTIVEMENT LES DIRECTIVES D'OPÉRATION ET D'ENTRETIEN AVANT DE FAIRE L'INSTALLATION, OU L'ENTRETIEN DE CET ÉQUIPEMENT.</p>

 CAUTION
<p>THE OVEN MUST REMAIN ON THE PALLET WHILE BEING MOVED TO THE INSTALLATION SITE BY FORK LIFT OR PALLET LIFT TRUCK.</p>

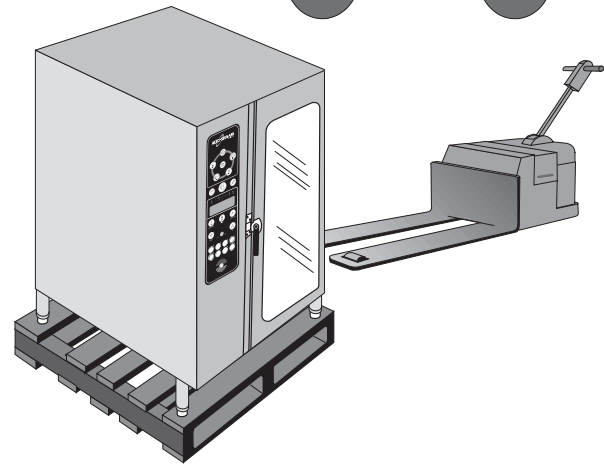
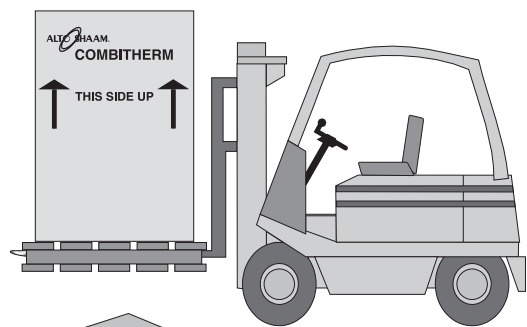

NOTE: Note dimensions required for doorways and aisles for access of the oven and pallet to the installation site. Transport the oven in an upright and level position only. Do not tilt the oven.

INSTALLATION CODES & STANDARDS

The following codes and standards are required for installation of this oven:
AIR SUPPLY, ELECTRICAL CONNECTIONS, WATER CONNECTIONS, AND WASTE WATER DISCHARGE.

<p>Where automatically operated appliances are vented through a ventilating hood or exhaust system equipped with a damper or with a power means of exhaust, provisions shall be made to allow the equipment to operate only when the damper is open to a position to properly vent the appliance and when the power means of exhaust is in operation.</p> <p>IN ACCORDANCE WITH NFPA 54 COMMONWEALTH OF MASSACHUSETTS ONLY.</p>	NOTE
---	------

VENTILATION REQUIREMENTS

A steam ventilation hood is mandatory for the operation of the oven. The ventilation hood must be installed in accordance with local building codes for the steam exhaust and must protrude 12-inches to 20-inches (300 to 500mm) over the front side of the oven. A grease filter must be located in the protruding area of the hood. Grease filters should be thoroughly cleaned on a regular basis following manufacturer's instruction. Ventilation hoods must ensure an adequate amount of incoming air during operation and must be operated whenever the combination oven/steamer is used in order to avoid the accumulation of condensation in the hood area.

POSITIONING ON SITE

Lift the oven from the pallet with a fork lift or pallet lift truck positioned at the front of the oven. For damage protection, the use of two wooden boards, placed between the bottom of the oven and the lifting forks, is strongly recommended. To avoid damage, position the lift forks to the left of the condenser and right of the right leg as indicated in the diagram at right.

Stand the oven in a level position. Use the adjustable feet to overcome an uneven floor and ensure that the unit is level.

It is strongly recommended that table top models be mounted on a factory supplied stand or a stand that is stable, open, level, and non-combustible. Recommended height is 23-inches (584mm).

Adjust the height of floor models for smooth access of the trolley or cart. When positioning the oven, observe the minimum space allocation requirements shown.

To insure proper operation, the installation of this oven must be completed by qualified technicians in accordance with the instructions provided in this manual. Failure to follow the instructions provided may result in damage to the oven, building, or cause personal injury to personnel.

CAUTION



**TO PREVENT PERSONAL INJURY,
USE CAUTION WHEN MOVING OR
LEVELING THIS APPLIANCE.**

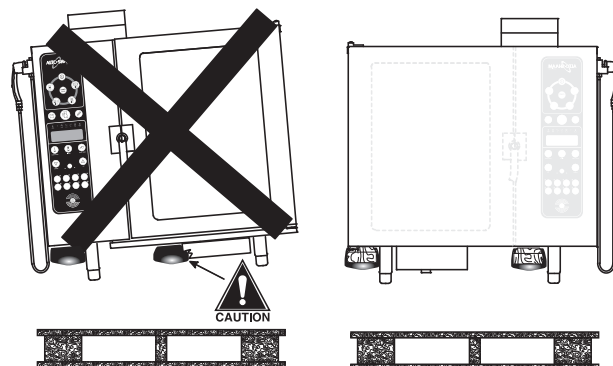

NOTE: To avoid equipment damage, observe attention label on oven for area to avoid with lifting fork.

MINIMUM CLEARANCE REQUIREMENTS	
LEFT SIDE	6" (152mm) MINIMUM 18" (457mm) SERVICE ACCESS RECOMMENDED 20" (508mm) FROM HEAT PRODUCING EQUIPMENT
RIGHT SIDE	4" (102mm)
BACK	4" (102mm) FOR PLUMBING
TOP	20" (508mm) FOR AIR MOVEMENT

NOTE: Additional clearance is needed for service access. A minimum distance of 18-inches is strongly recommended. If adequate service clearance is not provided, it will be necessary to disconnect the gas, water, and drain to move the oven with a fork lift for service access. Charges in connection with inadequate service access is not covered under warranty.

POSITIONING REQUIREMENTS

❑ In order to ensure proper ventilation, a minimum distance of at least 6-inches (152mm) must be kept from the control panels side (left) of the oven and any adjoining surfaces.

NOTE: Additional clearance is needed for service access. A minimum distance of 18-inches is strongly recommended. If adequate service clearance is not provided, it will be necessary to disconnect the gas, water, and drain to move the oven with a fork lift for service access. Charges in connection with inadequate service access is not covered under warranty.

❑ Allow a minimum of 4-inches (102mm) from the right side of the oven to allow the door to open to at least a 90° angle. Fully opened, the door will extend up to a 225° angle. If the oven is furnished with the retractable door option, allow a minimum clearance of 6-1/2 inches (165mm).

❑ Allow a minimum clearance of 4-inches (102mm) from the back of the oven for plumbing connections.

❑ Allow a 20-inch (500mm) clearance at the top of the oven for free air movement and for the steam vent(s) located at the top.

❑ Do not install the oven adjacent to heat producing equipment such as fryers, broilers, etc. Heat from such appliances may cause damage to the controls of the Combitherm. Minimum clearance recommended: 20-inches (500mm)

Place the Combitherm oven on a stable, non-combustible level horizontal surface. For countertop models, the oven stand must be level. In addition, the overall height of the oven should be positioned so the operating controls and shelves may be conveniently reached from the front. Level the oven front-to-back and side-to-side by means of the adjustable legs.

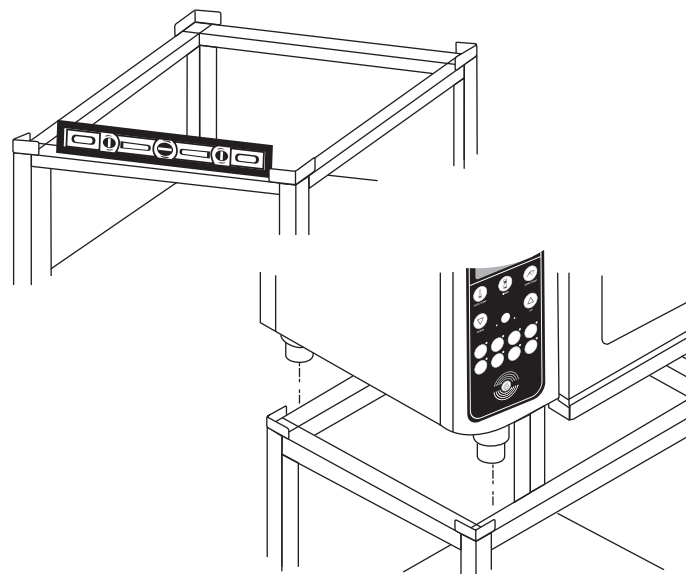
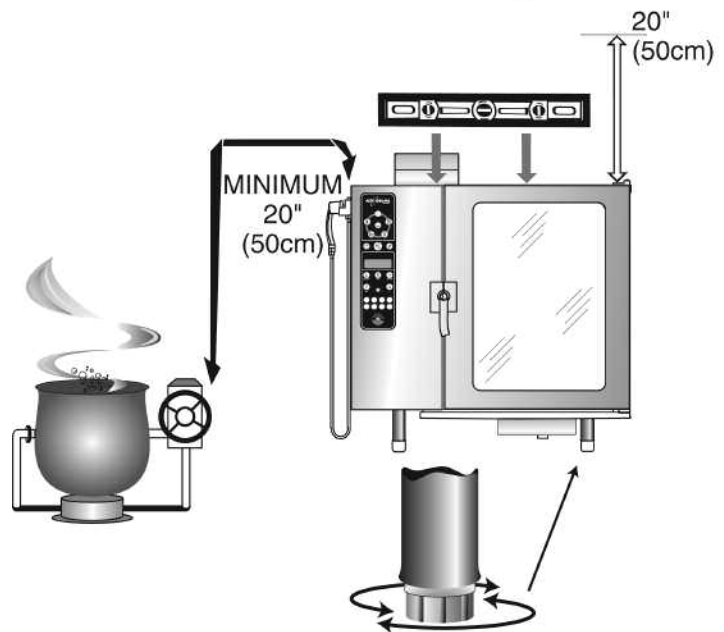
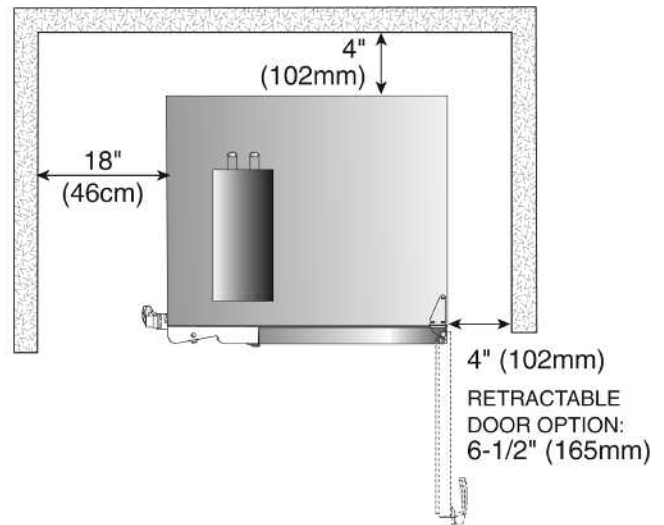
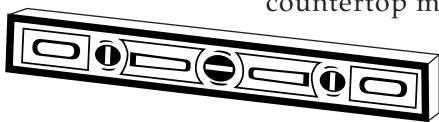

⚠ DANGER

ENSURE POWER SOURCE MATCHES VOLTAGE STAMPED ON APPLIANCE NAMEPLATE.

An electrical wiring diagram is located behind the control panel on the left side of the oven. The oven must be installed by a qualified electrician. This appliance must be branch circuit protected with proper ampacities, in accordance with the wiring diagram located in the electrical compartment of the oven. The oven must be properly grounded in accordance with the National Electrical Code and applicable local codes.

⚠ DANGER

To avoid electrical shock, this appliance **MUST** be adequately grounded in accordance with local electrical codes or, in the absence of local codes, with the current edition of the National Electrical Code ANSI/NFPA No. 70. In Canada, all electrical connections are to be made in accordance with CSA C22.1, Canadian Electrical Code Part 1 or local codes.

Before operating the oven, check all cable connections in the electrical connection area for tightness since connections can loosen during transport.

⚠ DANGER

ELECTRICAL CONNECTIONS MUST BE MADE BY A QUALIFIED SERVICE TECHNICIAN IN ACCORDANCE WITH APPLICABLE ELECTRICAL CODES.

NOTE: After both water and electrical connections have been completed, operate the oven in any cooking mode for a period of 15 minutes and recheck the main power connections at the terminal block to make certain they remain tight.

Wire size for the main incoming power to the unit must match the minimum size listed in the specifications applicable to the specific oven model. For supply connections, locate the wire size posted on the label located on the electrical control box cover, behind the service panel.

380-415V:

To prevent an electrical shock hazard between the appliance and other appliances or metal parts in close vicinity, an equalization-bonding stud is provided. An equalization bonding lead must be connected to this stud and the other appliances / metal parts to provide sufficient protection against potential difference. The terminal is marked with the following symbol.



When connecting to a Delta-B (wild leg) on a 3-phase system, the wild leg must be connected to line 3.

⚠ WARNING

FOLLOWING ELECTRICAL CONNECTION, THE FAN **MUST** ROTATE IN THE SAME DIRECTION AS THE ARROW LOCATED ON THE OVEN FAN MOTOR.

THIS APPLIANCE WILL NOT FUNCTION PROPERLY AND DAMAGE CAN OCCUR IF THE MOTOR ROTATION IS NOT CORRECT.

TO CHANGE MOTOR DIRECTION, EXCHANGE TWO OF THE INCOMING PHASES.

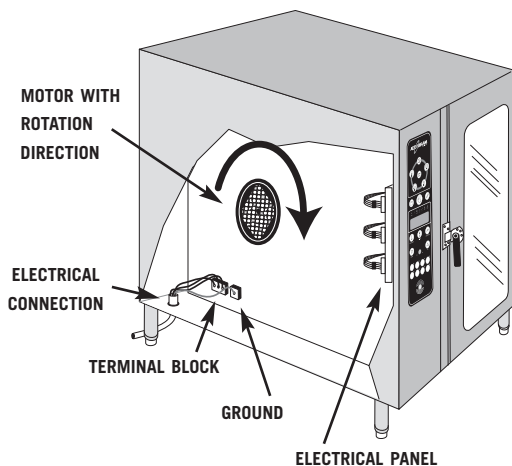

DRIP TRAY INSTALLATION

The appliance is shipped without the drip tray installed. This must be installed before equipment operation begins.

- 1 Position drip tray mounting bracket beneath oven. Secure with lock washer and phillips screws supplied.
- 2 Slide drip tray assembly into mounting bracket. Secure with lock washer and nut.
- 3 Attach drip tray hose to drip tray assembly. Secure the drain fitting connection with the 19mm clamp. Pull hose tight, cut hose to length, and secure the drip tray hose connection with the 20mm clamp.

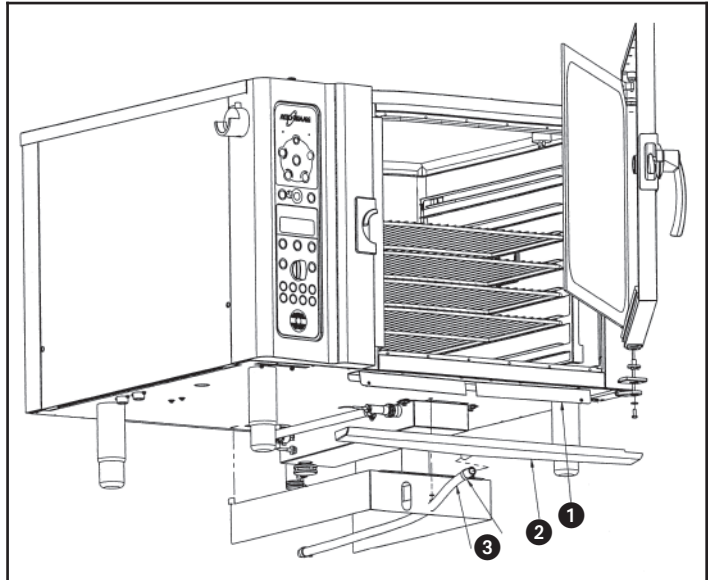

ITEM NO.	PART NO.	PART DESCRIPTION	QTY
1	1006674	DRIP TRAY MOUNTING BRACKET	1
2	—	DRIP TRAY	1
3	HO-27220	DRIP TRAY HOSE	1

WARNING

FAILURE TO PROPERLY INSTALL THE DRIP TRAY CAN OR WILL CAUSE MAJOR EQUIPMENT DAMAGE AND WILL RESULT IN A LEAKAGE HAZARD THAT CAN CAUSE PERSONAL INJURY.

MOBILE EQUIPMENT RESTRAINT

Any appliance that is not furnished with a power supply cord but includes a set of casters must be installed with a tether. Adequate means must be provided to limit the movement of this appliance without depending on or transmitting stress to the electrical conduit. The following requirements apply:

1. Casters must be a maximum height of 6" (152mm).
2. Two of the casters must be the locking type.
3. Such mobile appliances or appliances on mobile stands must be installed with the use of a flexible connector secured to the building structure.

A mounting connector for a restraining device is located on the lower back flange of the appliance chassis or on an oven stand, approximately 18" (457mm) from the floor. A flexible connector is not supplied by nor is it available from the factory.

WARNING

RISK OF ELECTRIC SHOCK.

Appliance must be secured to building structure.

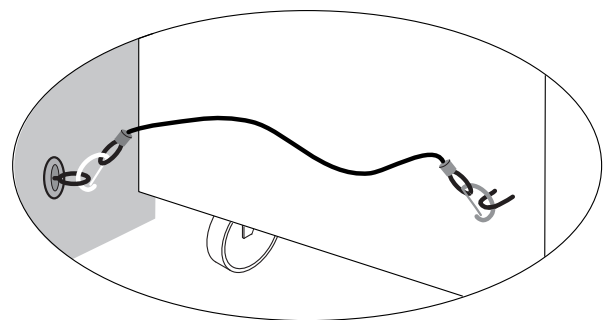

WATER QUALITY REQUIREMENTS

USE A DRINKING QUALITY, COLD WATER SUPPLY ONLY

Water quality is of critical importance when installing steam producing equipment of any kind, particularly *high temperature* steam producing equipment. Water that is perfectly safe to drink is composed of chemical characteristics that directly affect the metal surfaces of steam producing equipment. These chemical characteristics differ greatly from region to region throughout the U.S. and the world. *Varying combinations of pH; alkalinity; hardness; chlorides; total dissolved solids; and other chemical characteristics, when subjected to high temperatures, will cause water to have a tendency to either scale or corrode.*

Alto-Shaam has consulted with people who understand the properties of water in order to provide water quality standards that meet the broadest possible range of acceptable water quality requirements to help protect your investment.

We strongly urge water testing to ascertain the water quality on site prior to the installation of any steam producing equipment. Since water quality is an important issue, Alto-Shaam is committed to provide as much information as possible to help protect the investment made in this equipment.

A CombiGuard™ Water Filtration System can be purchased as an option for installation on the Combitherm oven. This filter, when properly installed, maintained, and combined with the required levels of steam generating equipment maintenance, will help lessen the affect water has on metal surfaces. It will not, however, provide complete protection against all water damage from region to region.

Due to the complexity of water chemistry, it is important to understand that water quality plays a significant role in the longevity of steam producing equipment. Water quality and required maintenance of steam generating equipment is the direct responsibility of the owner/operator. Damage incurred as a direct result of poor water quality and/or surfaces affected by water quality is also the responsibility of the owner/operator. Damage due to water quality that does not meet the minimum standards shown below is not covered under the Alto-Shaam Combitherm warranty.

Alto-Shaam will continue our efforts to provide viable solutions to ease the impact of water quality as it relates to steam generating equipment.

ALTO-SHAAM COMBITHERM WATER QUALITY MINIMUM STANDARDS

CONTAMINANT	INLET WATER REQUIREMENTS (UNTREATED WATER)
Free Chlorine	Less than 0.1 ppm (mg/L)
Hardness	Less than 3 gpg (52 ppm)
Chloride	Less than 30 ppm (mg/L)
pH	7.0 to 8.5
Alkalinity	Less than 50 ppm (mg/L)
Silica	Less than 12 ppm (mg/L)
Total Dissolved Solids (tds)	Less than 60 ppm



WARNING

TO PREVENT WATER PIPES OR HOSES FROM BURSTING, INCOMING WATER SUPPLY SHOULD BE TURNED OFF WHEN THE APPLIANCE IS NOT IN USE.



WARNING

WATER SUPPLY MUST BE OPEN WHEN CLEANING PROGRAM IS ACTIVATED.

VERIFY WATER SUPPLY BEFORE STARTING CLEANING PROGRAM.

WATER REQUIREMENTS

TWO (2) COLD WATER INLETS - DRINKING QUALITY

- ONE (1) TREATED WATER INLET: 3/4" NPT*
- ONE (1) UNTREATED WATER INLET: 3/4" NPT*
- LINE PRESSURE: 30 to 90 psi
2.8 to 6.2 bar

* Can manifold off of one 3/4" line
REFER TO PUBLISHED SPECIFIC WATER REQUIREMENTS

WATER DRAIN: 1-1/2" CONNECTION WITH AIR GAP

Flush the water line at the installation site before connecting the oven to the water supply. A hose connector is supplied for flexible hose connection to the **COLD** water source.

PIPE SEALING TAPE (TEFLON®) MUST BE USED AT ALL CONNECTION POINTS. The use of a pipe sealing compound is not recommended.

ONE SUGGESTED METHOD OF INSTALLATION

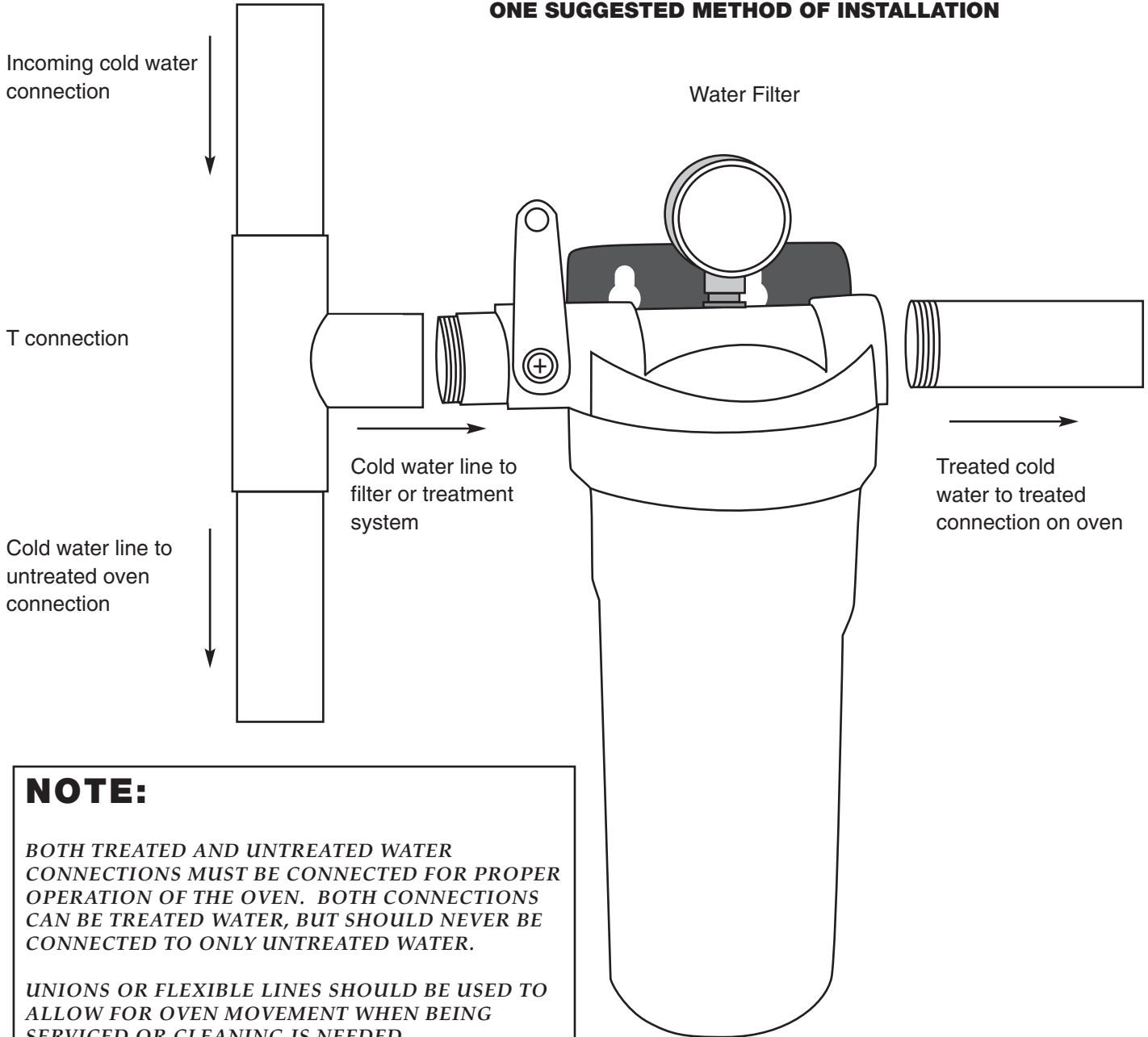

NOTE:

BOTH TREATED AND UNTREATED WATER CONNECTIONS MUST BE CONNECTED FOR PROPER OPERATION OF THE OVEN. BOTH CONNECTIONS CAN BE TREATED WATER, BUT SHOULD NEVER BE CONNECTED TO ONLY UNTREATED WATER.

UNIONS OR FLEXIBLE LINES SHOULD BE USED TO ALLOW FOR OVEN MOVEMENT WHEN BEING SERVICED OR CLEANING IS NEEDED.

REFER TO DIMENSION DRAWINGS BEGINNING ON PAGE 4 FOR PROPER INTAKE LOCATIONS.

NOTE:

THE SHUT-OFF VALVE
MUST BE IN THE OPEN POSITION
WHEN THE OVEN IS BEING USED.

SHUT-OFF VALVE SHOWN
IN THE OFF POSITION



ITEM FI-23014

Alto-Shaam now offers an improved water filtration system for Combitherm®. The CombiGuard™ triple-guard water filtration system filters dirt, sediment, and other debris as small as 1/2 micron. This system also significantly reduces chlorine content to protect against corrosive chlorine compounds. CombiGuard improves equipment efficiency, reduces service requirements and extends the life of the Combitherm. Filtration system includes one filter cartridge. Additional cartridges (**FI-26356**) can be purchased separately.

WATER DRAINAGE

The oven must discharge through an indirect waste pipe by means of an air gap. The drain fitting is supplied with a 1-1/2-inch (41mm) NPT thread on one end and a 1-1/2-inch (41mm) barbed connection on the opposite end.

A union is required. Install a 1-1/2-inch (41mm) diameter connection, drain line and clamp into place. The drain line must always be a positive gradient away from the Combitherm oven and not more than 12-inches (305mm) before an air gap.

NOTE: In the U.S.A., this equipment is to be installed to comply with the Basic Plumbing Code of the Building Officials and Code Administrators International, Inc. [BOCA], and the Food Service Sanitation Manual of the Food & Drug Administration [FDA].

If several units are to be connected to one drain pipe, the dimensions of the pipe must be sufficient to allow an unobstructed water drain system.

**AVERAGE
DRAIN WATER
TEMPERATURE
149°F (65°C)**

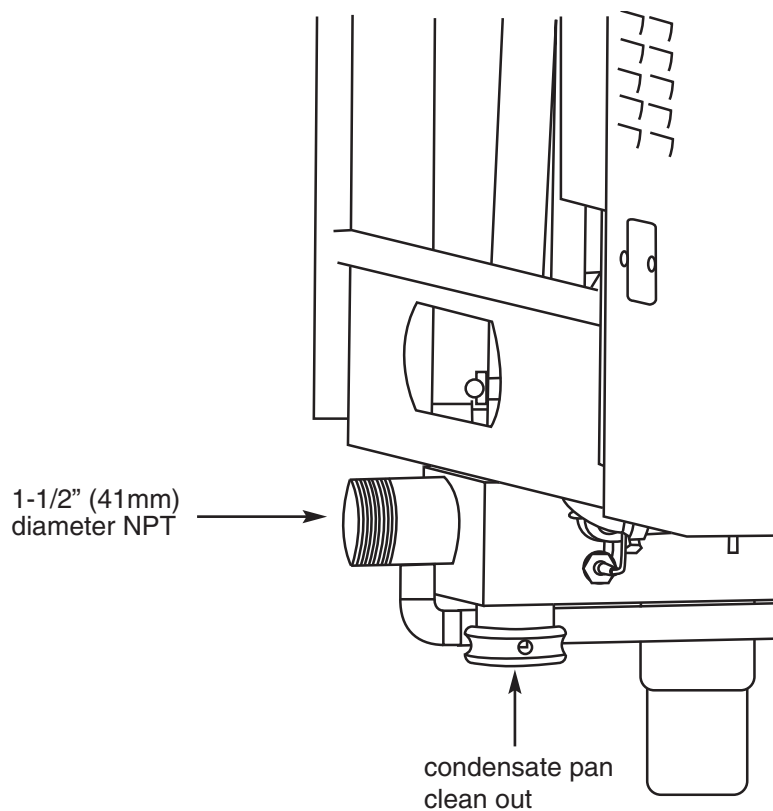
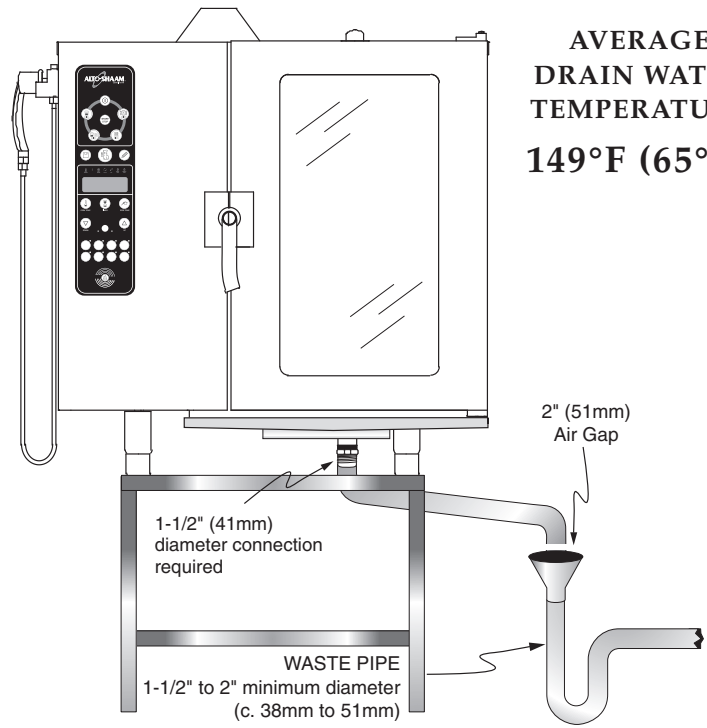

Use this list as a final check of oven installation conformance. Damage directly attributed to improper set up, installation, or cleaning can invalidate warranty claims.

CLEARANCES:

Left: 6" (152mm) — Service access of 18" (457mm) recommended.
 20" (508mm) from heat producing equipment.
 Right: 4" (102mm)
 Back: 4" (102mm) for plumbing
 Top: 20" (508mm) for air movement

ARE ALL CLEARANCE REQUIREMENTS MET? YES NO
 IF NO, EXPLAIN: _____

WATER SUPPLY AND DRAINS:

Verify hook-up to **TWO** (2) separate *cold* water supply lines with a 3/4" (19mm) water connection supply line. Verify inlet water pressure is at a minimum of 30 PSI (2.8 bar). Maximum water pressure is not to exceed 90 PSI (6 bar). Verify drain diameter of 1-1/2" (41mm) with a positive descending slope, and with a 2" (51mm) air gap which is free of obstructions before connection to the site drain. Verify 1/8" (3,2mm) pitch to 10' (305cm) of drain line.

IMPORTANT: Alto-Shaam has listed Water Quality Requirements in the installation manual for this equipment. It is the responsibility of the end user to have the water connected to this appliance tested to ensure these standards are met before putting the oven into use. Failure to meet these standards will void the warranty if damage to the oven is found to be related to water quality.

ARE BOTH WATER SUPPLY LINES PROPERLY CONNECTED? YES NO
 IF NO, EXPLAIN: _____

IS A FILTER SYSTEM INSTALLED ON THIS UNIT? YES NO

STORE HAS SEEN THIS RECOMMENDATION: YES NO

SIGNATURE OF STORE REPRESENTATIVE: _____

ELECTRICAL CONNECTIONS:

Verify electrical power requirements for oven.
 Verify voltage at terminal block. Check all terminals for tightness.

VOLTAGE: _____

PHASE: _____

BREAKER SIZE: _____

LINE VOLTAGE AT TERMINAL BLOCK (TO GROUND):

➤ LINE 1: _____ LINE 2: _____ LINE 3: _____

LINE VOLTAGE (PHASE TO PHASE): LINE 1 to 2: _____

LINE 2 to 3: _____

LINE 3 to 1: _____

ELECTRICAL SUPPLY LINE SIZE: _____

CORRECT MOTOR ROTATION: YES NO

ALL ELECTRICAL TERMINALS TIGHT: YES NO

CONTROL BOARD CONNECTIONS & OPERATION:

With the Power Key OFF, press and hold the Chef Function Key to access software version, and record.

SOFTWARE VERSION:

BM _____ SM _____ KM _____

ALL BOARD CONNECTIONS TIGHT: YES NO

ALL FUNCTIONS LIGHT UP: YES NO

ALL FUNCTIONS ON CONTROL OPERATE: YES NO

UNIT OPERATES IN ALL MODES: YES NO

IF NO, EXPLAIN: _____

PHYSICAL CONDITION:

*REFERENCE INSTALLATION INSTRUCTIONS FOR COMPLETE INFORMATION



Bottom of oven has been checked for damage due to improper positioning on site

Verify all gaskets, hoses, and carts* are in place and function properly

If oven includes a cart, verify proper installation of the rack guide*

Verify the installation of drip pans*, racks, shelves, drain screen, spray hose*

Verify the oven is level and installed on a solid, water resistant floor

SERVICE AGENCY:	START-UP DATE:
	INSTALLATION NAME:
MODEL NO.:	SERIAL NO.:
TECH SIGNATURE:	CUSTOMER SIGNATURE:

CONTROL RESET

There is a remote possibility in the day-to-day operation of the Combitherm that the control could lock or freeze. If this occurs, the control is easy to reset.

 PRESS AND HOLD THE POWER KEY FOR A PERIOD OF 5 SECONDS.

Release the POWER KEY.

The control will reset itself within approximately 15 seconds.

WHEN RESET, THE DISPLAY WILL INDICATE THE TIME AND DATE AND THE CONTROLS WILL BE FULLY FUNCTIONAL.

SERVICE MODE AND ERROR CODES

When the oven malfunctions, an error code will appear in the display.

 PRESS THE START KEY TO ACKNOWLEDGE THE ERROR.

The keys that begin to flash represent operational modes that are still usable. Refer to Emergency Operation.

When the oven fault is corrected, the Combitherm will return to normal Operation.

ERROR CODES AND REASONS

Error Code	Display Shows	When does the error occur?	Possible reason
E01	Low Water	ES units only: <ul style="list-style-type: none"> Activated if running in any mode and the water level drops below the low level sensor. Activated if not in running mode and the water level drops below the low level sensor for 3 minutes. 	<ul style="list-style-type: none"> Water supply is shut off. Low water pressure. Steam generator drain cap is off or loose. Drain pump is not sealing. Faulty or scaled water level probe. Faulty or plugged solenoid valve assembly. Wiring or connection issue.
E02	Control Temp High	Activated if the temperature of the electrical control is higher than 176°F for 20 seconds.	<ul style="list-style-type: none"> Cooling fan not operating. Unit is next to a heat producing source (there is less than 20" clearance for the control side). Exhaust hood is not operating (if applicable).
E03	Fan Malfunction	Activated if the motor protection switch is tripped.	<ul style="list-style-type: none"> Motor rotation is backwards. Incorrect power to the unit. Connection problem at X-7 plug on relay board pins 3-4.
E04	Aux Fan Fault	Auxiliary fan malfunction.	<ul style="list-style-type: none"> Control setup programming error. Contact factory.
E11	Excess Oven Temp	Activated if the oven cavity temperature is higher than 518°F for 25 seconds.	<ul style="list-style-type: none"> Connection issue with oven temperature sensor. Convection element contactor is stuck. Faulty oven temperature sensor.

ERROR CODES AND REASONS (continued)

Error Code	Display Shows	When does the error occur?	Possible reason
E13	Excess Steam Gen Temp	<p>ES units only: Activated if the temperature of the steam generator probe (B-4) is higher than 248°F for 26 seconds.</p> <p>ESi units only: Activated if the position of personality jumper on X-3 is incorrect. Activated if the position of B-4 jumper is incorrect.</p>	<ul style="list-style-type: none"> • Problem with water level probe. • Scale build-up inside steam generator. • Steam element contactor is stuck. • Connection issue with B-4 probe. • Faulty B-4 probe. • Jumper on X-3 is improperly positioned. Should be between 2-8 or, if it is a smoker, between 2-9. • Jumper on X-6a is improperly positioned. Should be between 13-14.
E15	Excess Condensate Temp	Activated if the temperature of the condensate probe (B-3) is higher than 212°F for 26 seconds.	<ul style="list-style-type: none"> • Water supply is shut off. • Faulty or plugged solenoid valve (Y-2). • Connection issue at B-3 probe. • Faulty B-3 probe.
E21	Oven Probe Fault	Activated if oven temperature probe (N-6) is interrupted.	<ul style="list-style-type: none"> • Connection issue at N-6 probe. • Faulty N-6 probe.
E22	Core Temp Probe Fault	Activated if cooking in Core Temp mode and the CTC sensor measures an excessive temperature.	<ul style="list-style-type: none"> • CTC sensor is damaged. • 4-point CTC sensor is activated, but 1-point CTC sensor is installed. • Cable connection of CTC sensor is damaged. • Hardware problem on control unit (SM).
E23	Steam Gen Probe Fault	<p>ES units only: Activated if the steam generator probe (B-4) is interrupted.</p> <p>ESi units only:</p> <ul style="list-style-type: none"> • Activated if the position of personality jumper on X-3 is incorrect. • Activated if the position of B-4 jumper is incorrect. 	<ul style="list-style-type: none"> • Connection issue at B-4 probe. • Faulty B-4 probe. • Jumper on X-3 is imperly positioned. Should be between 2-8 or, if it is a smoker, between 2-9. • Jumper on X-6a is improperly positioned. Should be between 13-14.
E24	Bypass Probe Fault	Activated if the bypass probe (B-5) is interrupted.	<ul style="list-style-type: none"> • Connection issue at B-5 probe. • Faulty B-5 probe.
E25	Condensate Probe Fault	Activated if the condensate probe (B-3) is interrupted.	<ul style="list-style-type: none"> • Connection issue at B-3 probe. • Faulty B-3 probe.
E26	Steam Gen Safety Probe Fault	Activated if the steam generator safety probe (N-8) is interrupted.	<ul style="list-style-type: none"> • Connection issue at N-8 probe. • Faulty N-8 probe.
E27	Excess Steam Gen Safety Temp	<p>Activated if the steam generator safety probe (N-8) measures a temperature in excess of 266°F.</p> <p>ESi units only:</p> <ul style="list-style-type: none"> • Activated if the position of N-8 jumper is incorrect. 	<ul style="list-style-type: none"> • Problem with water level probe. • Scale build-up inside steam generator. • Steam element contactor is stuck. • Connection issue with N-8 probe. • Faulty N-8 probe. • Jumper on X-6b is improperly positioned. Should be between 1-2.

ERROR CODES AND REASONS (continued)

Error Code	Display Shows	When does the error occur?	Possible reason
E29	Probe Short to Frame	Activated if one or more of the temperature sensors were connected to GND for 5 seconds.	<ul style="list-style-type: none"> • Connection issue at any of the temperature sensors. • Temperature sensor shorted to ground/faulty.
E34	DE (Drain) Pump Failure	Activated if water level did not drop below the low level sensor in the generator during a steam generator flush.	<ul style="list-style-type: none"> • Problem with water level probe. • Scale build-up inside steam generator. • Scale plugging drain pump. • Faulty drain pump.
E35	Venting Error	Activated when vent switch reads open (vent closed) when it should be closed (vent open), or when it reads closed (vent open) when it should be open (vent closed).	<ul style="list-style-type: none"> • Alignment issue between motor cam and micro switch. • Connection issue at micro switch. • Connection issue at control. • Faulty vent switch. • Faulty vent motor.
E36	Steam Temp High	Activated when oven temperature probe (N-6) measures a temperature in excess of 395°F when running in Steam or Combi mode.	<ul style="list-style-type: none"> • Water supply is shut off while unit is running in Steam or Combi mode. • Plugged or faulty Y-1 solenoid. • Obstruction between Y-01 solenoid and water inlet.
E80	ID Error	Control is unable to detect whether unit is gas or electric.	<ul style="list-style-type: none"> • Connection issue at X-3 personality jumper. • Faulty control.
E81	Program Memory Error	Temperature value or time value of a program step is not allowed.	<ul style="list-style-type: none"> • Program was generated in °C and control has been switched to °F. • Program was generated in °F and control has been switched to °C.
E82	WP Error	Temperature value or time value of current cooking algorithm is out of allowed array.	<ul style="list-style-type: none"> • Delete program and reinstall.
E83	Algo Error	Cooking algorithm sent by operating module (BM) is unknown to control unit (SM).	<ul style="list-style-type: none"> • Software versions of control unit and operating module are incompatible. • Software error in operating module.
E96	Connection Error	No or bad communication between control unit (SM) and operating module (BM).	<ul style="list-style-type: none"> • Connection issue at ribbon cable on display or relay board. • Faulty ribbon cable. • Software versions of control unit and operating module are incompatible.

EMERGENCY OPERATION

In the event of an error code, the Combitherm may be operated on a limited basis. Error conditions under which continued operation can be conducted are indicated by “Yes” in the chart shown below.

When the oven malfunctions, an error code will appear in the display.



PRESS THE START KEY TO ACKNOWLEDGE THE ERROR.

The keys that begin to flash represent operational modes that are still usable.

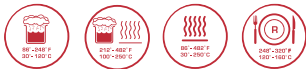

SELECT AND PRESS ONE OF THE COOKING MODES INDICATED.

The oven control will only respond to the mode keys that are flashing.

SET THE OVEN CONTROLS AS IF OPERATING UNDER NORMAL CIRCUMSTANCES.

Depending on the error code involved, oven function, such as temperature range, may be limited.



PRESS THE START KEY TO BEGIN THE COOKING PROCESS.



PRESS THE START KEY WHEN THE TIMER EXPIRES.

When the oven fault is corrected, the Combitherm will return to normal Operation.

CONTINUED OPERATION UNDER ERROR CONDITIONS

Error Code	Display Shows	ES	ESi	Steam Mode	Combination Mode	Convection Mode	Retherm Mode
E01	Low Water	Yes	No	No	No	To 365°F	No
E02	Control Temp High	Yes	Yes	Yes	To 284°F	To 284°F	To 284°F
E03	Fan Malfunction	No	No	—	—	—	—
E04	Aux Fan Fault	Yes	Yes	Yes	To 284°F	To 284°F	To 284°F
E11	Excess Oven Temp	Yes	Yes	No	No	No	No
E13	Excess Steam Gen Temp	Yes	No	No	No	No	No
E15	Excess Condensate Temp	Yes	Yes	No	No	To 356°F	No
E21	Oven Probe Fault	Yes	Yes	212°F only	No	No	No
E22	Core Temp Probe Fault	Yes	Yes	Yes	Yes	Yes	Yes
E23	Steam Gen Probe Fault	Yes	No	Yes	Yes	Yes	Yes
E24	Bypass Probe Fault	Yes	Yes	To 210°F	No	Yes	No
E25	Condensate Probe Fault	Yes	Yes	Yes	To 356°F	To 356°F	To 320°F
E26	Steam Gen Safety Probe Fault	Yes	No	Yes	Yes	Yes	Yes
E27	Excess Steam Gen Safety Temp	Yes	No	No	No	No	No
E29	Probe Short to Frame	Yes	Yes	No	No	No	No
E34	DE (Drain) Pump Failure	Yes	No	Yes	Yes	Yes	Yes
E35	Venting Error	Yes	Yes	Yes	Yes	Yes	Yes
E36	Steam Temp High	No	Yes	No	No	Yes	No
E80	ID Error	Yes	Yes	Yes	Yes	Yes	Yes
E81	Program Memory Error	Yes	Yes	Yes	Yes	Yes	Yes
E82	WP Error	Yes	Yes	Yes	Yes	Yes	Yes
E83	Algo Error	Yes	Yes	Yes	Yes	Yes	Yes
E96	Connection Error	Yes	Yes	No	No	No	No



The Ventless Hood option is factory installed directly on the top of the Alto-Shaam Combitherm oven. The hood is designed to vent clean air back into the kitchen, filtering vapors and grease. A high-power fan draws steam and fumes into the hood intake and out the top surface exhaust vent. Fumes and vapors are circulated through filters draining the condensation through a drain at the rear of the hood. An activated charcoal filter cleans the air before venting it out the top of the hood.

CONDENSATE DRAIN

A ventless hood condensate drain line to the floor drain must be installed. The 3/4" NPT thread connection is found at the back of the hood. The drain line must always be a positive gradient away from the Combitherm.



OPENING MECHANISM

Using a coin or screwdriver, turn to open; reverse procedure to close and latch.

Hood and oven will not operate unless this is closed properly.

OPERATION

- ❶ Turn the ventless hood power knob "ON".
- ❷ Wait five seconds, then press the "COMBI RESET" button.
- ❸ Turn the Combitherm oven power "ON".

There are a number of safety features incorporated into the operation of the hood which are directly related to the interaction of hood function and the operation of the combi oven/steamer.

INDICATOR LIGHTS

If the indicator lights do not illuminate, the filters may be missing or not properly aligned. Check them for proper positioning. Ventless hood and oven will not operate unless the hood is closed properly.

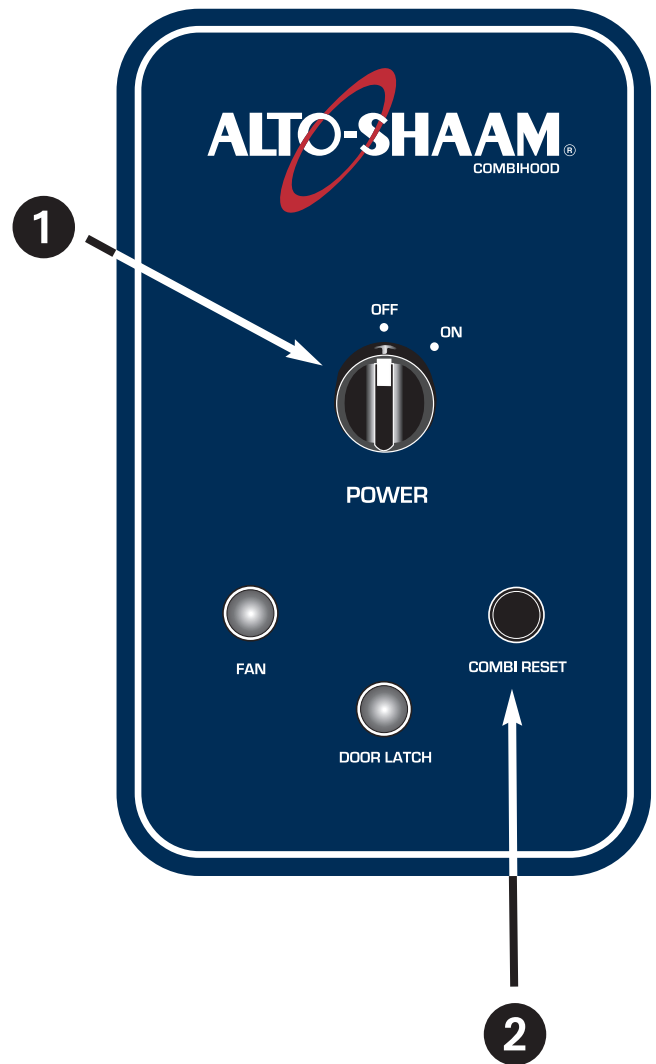

INTERLOCK SWITCHES

CHARCOAL FILTER SWITCH, GREASE FILTER SWITCH:
Prevents hood and oven operation if any filter is not in place or is improperly installed.

FAN PRESSURE SWITCH:
Prevents Combi oven operation if hood fan is not operating or if the filters are more than 25% blocked.

TIMED LATCHING MECHANISM

In order to evacuate steam and grease-laden air from the oven interior, this mechanism prevents the operator from fully opening the oven door for 25

seconds to one minute. The mechanism automatically disengages at the end of a pre-set time allowing full door extension.

RESET SWITCH

The reset has to be used if the Combitherm oven is turned on before the hood or if the hood was opened. It resets the pressure switch circuit and provides power to the Combitherm control circuit. This switch must also be used to reset hood controls after any problem with the filters, or the improper latching of the ventless hood door.



CHARCOAL FILTER
FI-24114 (VHes-5)
FI-24102 (VHes-10)

GREASE FILTER
FI-24113 (VHes-5)
FI-23062 (VHes-10)

CLEANING AND MAINTENANCE

To ensure optimum performance from the ventless hood, it is important to establish and maintain a regular cleaning and maintenance schedule.

To help maintain the protective film coating on polished stainless steel, clean the exterior of the cabinet with a cleaner recommended for stainless steel surfaces. Spray the cleaning agent on a clean cloth and wipe with the grain of the stainless steel.

CHARCOAL FILTER

The charcoal filter should be inspected for contaminant's on a regular basis. Replacement must be made at a minimum of three month intervals — more often if heavy contaminant's are visible or if the filter no longer controls odors.

To remove the filter, pull and slide out while holding the bottom housing. **When replacing the filter, make certain the air flow arrow(s) point toward the hood fan, and that the filter is replaced in the three-sided metal frame provided with the hood.**

GREASE FILTERS AND METAL HOUSING (PLENUM)

Cleaning frequency should be based on oven usage with a maximum of two weeks between cleaning if the oven is used for non-grease laden products or steam applications only. Grease laden products such as red meat, poultry, etc., require cleaning frequency of at least once a week. Remove the grease filter by pulling it straight out of the housing. Place the filter in the dishwasher or wash separately by placing in hot, soapy water until all grease and particles have been removed. Rinse thoroughly. Allow the filter to air dry before reinstalling.

Clean the interior metal housing (plenum) with a damp cloth and any good commercial detergent or grease solvent at the recommended strength. Avoid the use of abrasive cleaning compounds, chloride based cleaners, or cleaners containing quaternary salts. Use a degreasing agent if necessary.

To replace the grease filter, the air flow arrow on the filter casing should be pointing toward the hood fan.

Alto-Shaam, Inc. warrants to the original purchaser that any original part that is found to be defective in material or workmanship will, at Alto-Shaam’s option, subject to provisions hereinafter stated, be replaced with a new or rebuilt part.

The labor warranty remains in effect one (1) year from installation or fifteen (15) months from the shipping date, whichever occurs first. Alto-Shaam will bear normal labor charges performed by an authorized Alto-Shaam service agent during standard business hours, and excluding overtime, holiday rates or any additional fees.

The parts warranty remains in effect for one (1) year from installation or fifteen (15) months from the shipping date, whichever occurs first.

THIS WARRANTY DOES NOT APPLY TO:

1. Replacement of light bulbs.
2. Equipment damage caused by accident, shipping, improper installation or alteration.
3. Steam generator or steam generating system damage as a result of inadequate routine maintenance and cleaning. Required maintenance and cleaning of steam generating equipment is the responsibility of the owner/operator.
4. Equipment used under conditions of abuse, misuse, carelessness or abnormal conditions including, but not limited to, equipment subjected to harsh or inappropriate chemicals including, but not limited to, compounds containing chlorine, chlorides or quaternary salts, or equipment with missing or altered serial numbers.
5. Equipment that uses water must meet Alto-Shaam’s minimum water quality standards as shown below. **USE OF WATER NOT MEETING ALTO-SHAAM’S MINIMUM WATER QUALITY STANDARDS WILL VOID THIS WARRANTY.** Water quality and required maintenance of steam generating equipment is the responsibility of the owner/operator. The installation and use of Alto-Shaam’s CombiGuard™ Water Filtration System is highly recommended.

ALTO-SHAAM COMBITHERM WATER QUALITY MINIMUM STANDARDS

CONTAMINANT	INLET WATER REQUIREMENTS (UNTREATED WATER)
Free Chlorine	Less than 0.1 ppm (mg/L)
Hardness	Less than 3 gpg (52 ppm)
Chloride	Less than 30 ppm (mg/L)
pH	7.0 to 8.5
Alkalinity	Less than 50 ppm (mg/L)
Silica	Less than 12 ppm (mg/L)
Total Dissolved Solids (tds)	Less than 60 ppm

6. Damage caused by use of any cleaning agent other than Alto-Shaam’s Combitherm® Oven Cleaner including, but not limited to, damage due to chlorine, bleach, quaternary salts, scouring powders or other harmful chemicals. Use of Alto-Shaam’s Combitherm Cleaner on Combitherm ovens is highly recommended.
7. Any losses or damage resulting from malfunction, including loss of product or other consequential or incidental damages of any kind.
8. Equipment modified in any manner from original model, substitution of parts other than factory authorized parts, removal of any parts including legs, or addition of any parts.

THIS WARRANTY IS EXCLUSIVE AND IS IN LIEU OF ALL OTHER WARRANTIES, EXPRESSED OR IMPLIED, INCLUDING THE IMPLIED WARRANTIES OF MERCHANTABILITY AND FITNESS FOR A PARTICULAR PURPOSE. IN NO EVENT SHALL ALTO-SHAAM BE LIABLE FOR LOSS OF USE, LOSS OF REVENUE OR PROFIT, OR LOSS OF PRODUCT, OR FOR ANY INDIRECT, INCIDENTAL OR CONSEQUENTIAL DAMAGES.

No person except an officer of Alto-Shaam, Inc. is authorized to modify this warranty or to incur on behalf of Alto-Shaam any other obligation or liability in connection with Alto-Shaam equipment.



All Alto-Shaam equipment is sold F.O.B. shipping point, and when accepted by the carrier, such shipments become the property of the consignee.

Should damage occur in shipment, it is a matter between the carrier and the consignee. In such cases, the carrier is assumed to be responsible for the safe delivery of the merchandise, unless negligence can be established on the part of the shipper.

1. Make an immediate inspection while the equipment is still in the truck or immediately after it is moved to the receiving area. Do not wait until after the material is moved to a storage area.
2. Do not sign a delivery receipt or a freight bill until you have made a proper count and inspection of all merchandise received.
3. Note all damage to packages directly on the carrier's delivery receipt.
4. Make certain the driver signs this receipt. If he refuses to sign, make a notation of this refusal on the receipt.
5. If the driver refuses to allow inspection, write the following on the delivery receipt:

Driver refuses to allow inspection of containers for visible damage.

6. Telephone the carrier's office immediately upon finding damage, and request an inspection. Mail a written confirmation of the time, date, and the person called.
7. Save any packages and packing material for further inspection by the carrier.
8. Promptly file a written claim with the carrier and attach copies of all supporting paperwork.

We will continue our policy of assisting our customers in collecting claims which have been properly filed and actively pursued. We cannot, however, file any damage claims for you, assume the responsibility of any claims, or accept deductions in payment for such claims.

RECORD THE MODEL AND SERIAL NUMBER OF THE APPLIANCE FOR EASY REFERENCE. ALWAYS REFER TO BOTH MODEL AND SERIAL NUMBER IN ANY CONTACT WITH ALTO-SHAAM REGARDING THIS APPLIANCE.

Model: _____

Serial Number: _____

Date Installed: _____

Voltage: _____

Purchased From: _____



Alto-Shaam has established a twenty-four hour emergency service call center to offer immediate customer access to a local authorized service agency outside of standard business hours. The emergency service access is provided exclusively for Alto-Shaam equipment and is available throughout the United States through the use of Alto-Shaam's toll-free number. Emergency service access is available seven days a week including holidays.