

OPERATING AND INSTALLATION INSTRUCTIONS

Model 751, 1001, 1501
TYPE H, WH, P

ADVANCED DESIGN BOILER

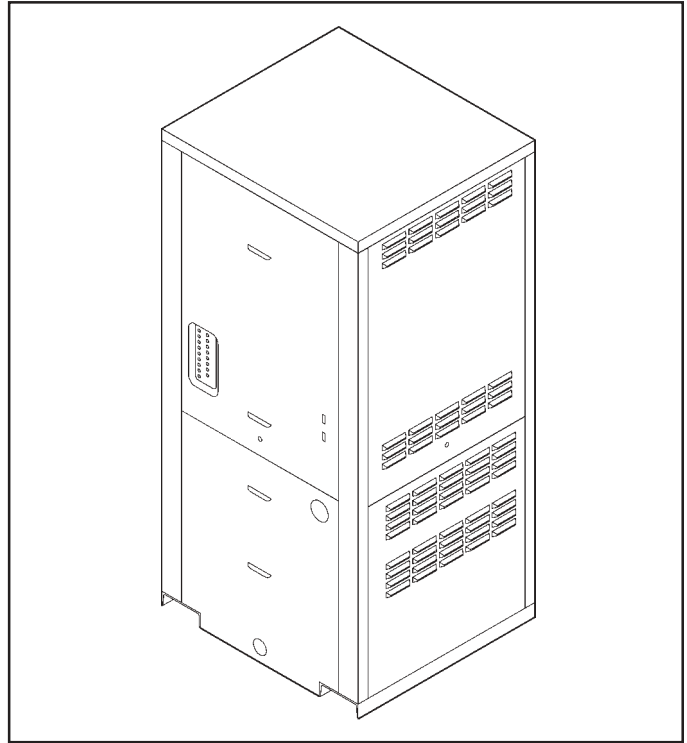

FOR YOUR SAFETY

Do not store or use gasoline or other flammable vapors and liquids or other combustible materials in the vicinity of this or any other appliance. To do so may result in an explosion or fire.

WARNING: Improper installation, adjustment, alteration, service or maintenance can cause property damage, personal injury or loss of life. Refer to the user's information manual provided with this boiler. Installation and service must be performed by a qualified installer, service agency or the gas supplier.

FOR YOUR SAFETY

WHAT TO DO IF YOU SMELL GAS:

- Do not try to light any appliance.
- Do not touch any electrical switch; do not use any phone in your building.
- Immediately call your gas supplier from a neighbor's phone. Follow the gas supplier's instructions.
- If you cannot reach your gas supplier, call the fire department.

This manual should be maintained in legible condition and kept adjacent to the boiler or kept in a safe place for future reference.



Raypak®

A Rheem® Company

DANGER:

Make sure the gas on which the boiler will operate is the same type as that specified on the boiler model and rating plate.

WARNING:

Should overheating occur or the gas supply valve fail to shut, do not turn off or disconnect the electrical supply to the boiler. Instead, shut off the gas supply at a location external to the appliance.

WARNING:

Do not use this boiler if any part has been under water. Immediately call a qualified service technician to inspect the boiler and to replace any part of the control system and any gas control which has been under water.

WARNING:

To minimize the possibility of improper operation, serious personal injury, fire, or damage to the boiler, never violate the following safety rules:

- 1. Always keep the area around the boiler free of combustible materials, gasoline, and other flammable liquids and vapors.*
- 2. Never cover the boiler, lean anything against it, store trash or debris near it, stand on it, or in any way block the flow of fresh air to the boiler.*

WARNING:

More than one (1) supply source. This appliance has provisions to be connected to more than one (1) supply source. To reduce the risk of electrical shock, disconnect all such connections before servicing.

WARNING:

Risk of electrical shock. More than one (1) disconnect switch may be required to de-energize the equipment before servicing.

CAUTION:

Operation of this boiler on low temperature systems requires special piping to insure correct operation. Consult Sections E, F or G for piping details.

CAUTION:

If this boiler is to be installed above radiation level, it must be provided with a low water cutoff device at the time of boiler installation.

CAUTION:

This boiler requires forced water circulation when the burner is operating. See sections D for minimum and maximum flow rates. Severe damage will occur if the boiler is operated without proper water flow circulation.

TABLE OF CONTENTS

PAGE NO.

4	SECTION A:	BEFORE INSTALLING THE BOILER
7	SECTION B:	BOILER INSTALLATION
10	SECTION C:	COMBUSTION AND VENTILATION AIR
12	SECTION D:	WATER PIPING - GENERAL
13	SECTION E:	HYDRONIC HEATING PIPING
17	SECTION F:	DOMESTIC HOT WATER PIPING
19	SECTION G:	POOL HEATING
22	SECTION H:	GAS SUPPLY CONNECTIONS
24	SECTION I:	ELECTRICAL POWER CONNECTIONS
27	SECTION J:	VENTING CONNECTIONS
49	SECTION K:	CONDENSATE DRAIN
50	SECTION L:	CONTROLS
56	SECTION M:	GENERAL SAFETY PRECAUTIONS
57	SECTION N:	PRE-START-UP
59	SECTION O:	ADB INITIAL START-UP (MANUFACTURERS CERTIFIED PERSONNEL ONLY)
62	SECTION P:	POST START-UP CHECK
63	SECTION Q:	OPERATION
64	SECTION R:	MAINTENANCE
66	SECTION S:	CONNECTING CONDENSING HEAT EXCHANGER (CHX)
67	APPENDIX A:	COMBUSTION AIR CONTAMINATION
68		ILLUSTRATED PARTS LIST
75		WARRANTY

Pay attention to these terms:

DANGER indicates the presence of immediate hazards which will cause severe personal injury, death or substantial property damage if ignored.

WARNING indicates the presence of hazards or unsafe practices which could cause severe personal injury, death or substantial property damage if ignored.

CAUTION indicates the presence of hazards or unsafe practices which could cause minor personal injury or product or property damage if ignored.

NOTICE indicates special instructions on installation, operation, or maintenance which are important but not related to personal injury hazards.

SECTION A: BEFORE INSTALLING THE BOILER

Raypak strongly recommends that this manual be reviewed thoroughly before installing your Raypak boiler. Factory warranty does not apply to boilers that have been improperly installed or operated. Installation and service must be performed by a qualified installer, service agency or gas supplier. If, after reviewing this manual, you still have questions which this manual does not answer, please contact the factory or your local Raypak representative.

Thank you for purchasing a Raypak product. We hope you will be satisfied with the high quality and durability of our equipment.

PRODUCT RECEIPT

On receipt of your product it is suggested that you visually check for external damage to the shipping crate. If the crate is damaged, make a note to that effect on the Bill of Lading when signing for the shipment. Remove the boiler from the shipping packaging. Report any damage to the carrier immediately.

On occasion, some items will be shipped loose. Be sure that you receive the correct number of packages as indicated on the Bill of Lading.

Claims for shortages and damages must be filed with the carrier by consignee. Permission to return goods must be received from the factory prior to shipping. Goods returned to the factory without an authorized Returned Goods Receipt number will not be accepted. All returned goods are subject to a stocking charge.

When ordering parts, you must specify the Model and Serial Number of the boiler. When ordering under warranty conditions, you must also specify the date of installation.

Purchased parts are subject to replacement only under the manufacturer's warranty. Debits for defective replacement parts will not be accepted and will be replaced in kind only per Raypak's standard warranties.

MODEL IDENTIFICATION

The model identification number and boiler serial number are found on the boiler data plate located on the left inside jacket of the boiler. The model number will have the form H4 0500A ADB or similar depending on the boiler size and configuration. The first character of the model number identifies application (H = Hydronic Heating System, W = Hot Water Supply System, P = Pool Application). The second character identifies the firing mode (4 = On-Off firing). The next four places identify the input of the boiler in 1,000s of BTUH 0500 = 500,000 BTUH). The remaining suffix identifies the control, ignition, and construction configuration. The last three characters of the model number identifies the model type (ADB = Advanced Design Boiler).

RATINGS AND CERTIFICATION

All Raypak boilers are National Board Approved, design certified and tested under the applicable American National Standard/CSA Standard for USA and Canada. Each boiler is constructed in accordance with Section IV of the American Society of Mechanical Engineers (ASME) Boiler Pressure Vessel Code and bears the ASME stamp. This boiler complies with the latest edition of ASHRAE 90.1 Standard.

Altering any RAYPAK pressure vessel by installing replacement heat-exchangers, tube bundle headers, or any other ASME part not manufactured and/or approved by RAYPAK will instantly void the ASME, and agency listings and any RAYPAK warranty on the vessel. Altering the ASME, agency ratings of the vessel also violates national, state, and local approval codes. The terms "boiler" and "heater" are used interchangeably in this manual.

No derate is required for altitudes up to 7000 feet. Rated inputs, at sea level settings, are suitable for up to 5000 feet elevation. At altitudes between 5000 and 7000 feet, rated inputs are achieved with pressure settings adjustment. Consult the factory for installations at altitudes in excess of 7000 feet.

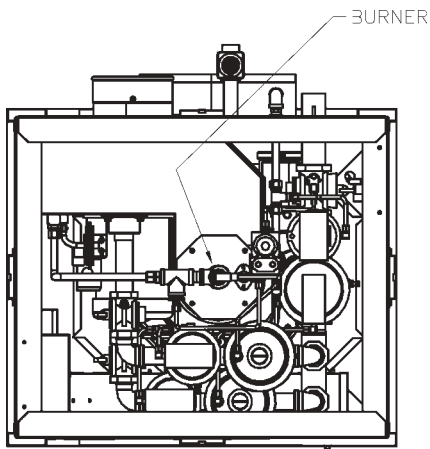

TOP VIEW

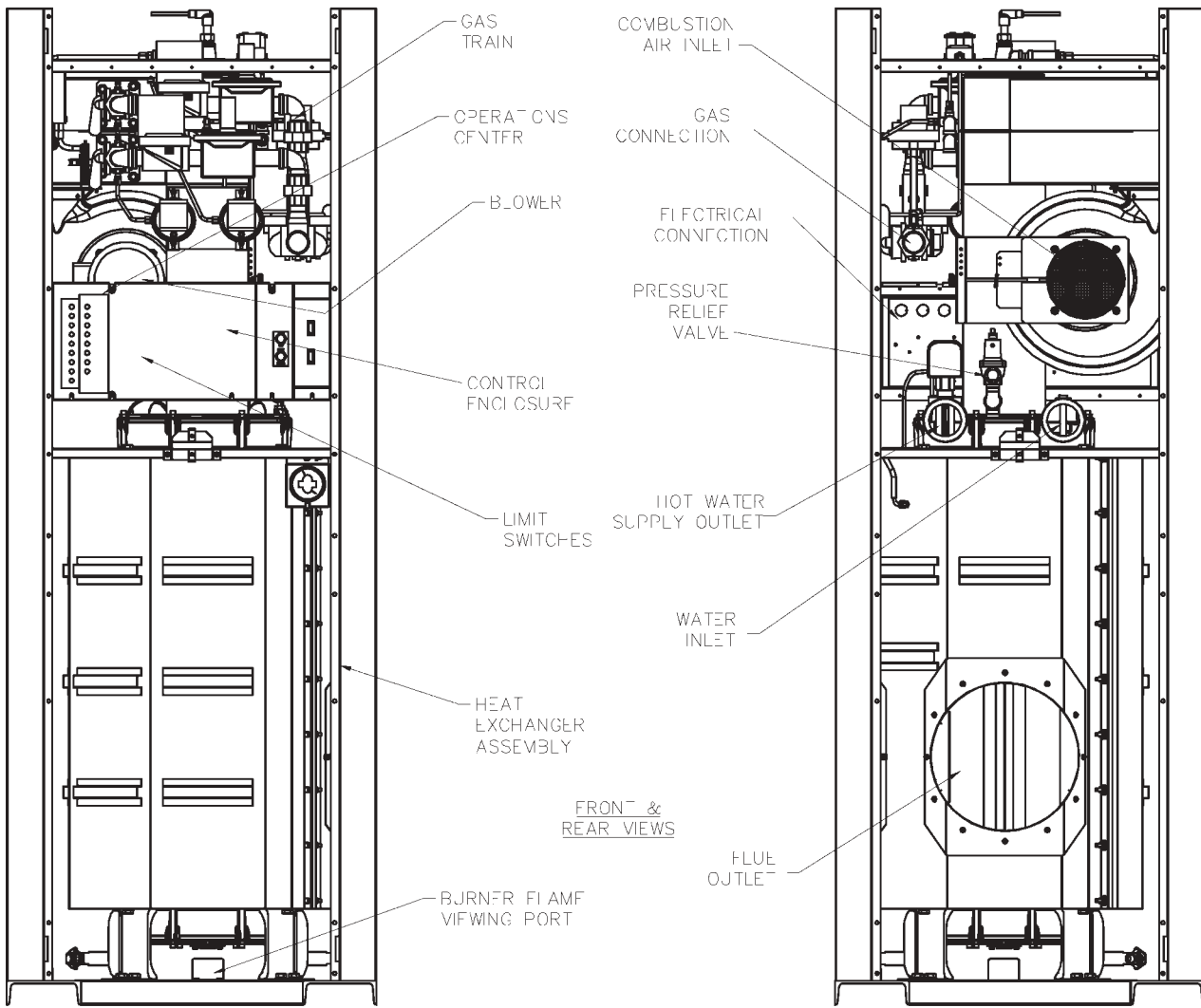

FRONT VIEW

REAR VIEW

**Figure A-1
ADVANCED DESIGN BOILER COMPONENT LOCATIONS**

SECTION B: BOILER INSTALLATION

INSTALLATION CODES

Installations must follow these codes:

- Local, state, provincial, and national codes, laws, regulations and ordinances.
- National Fuel Gas Code (NFGC), ANSI Z223.1- latest edition.
- National Electrical Code (NEC), ANSI/NFPA 70 - latest edition.
- Standard for Controls and Safety Devices for Automatically Fired Boilers, ANSI/ASME CSD-1, when required.
- For Canada only: CAN/CGA B149.1 and .2 Installation Code and C.S.A. C22. 1 C.E.C. Part 1.

EQUIPMENT BASE

The boiler should be mounted on a level, structurally sound surface. The boiler is approved for and can be installed on a combustible surface but must NEVER be installed on carpeting. Gas fueled equipment installed in enclosed parking garages must be located at least 18 inches above the floor.

CAUTION: The boiler should be located in an area where water leakage will not result in damage to the area adjacent to the appliance or to the structure. When such locations cannot be avoided, it is recommended that a suitable catch pan, adequately drained, be installed under the appliance. The pan must not restrict air flow.

In addition, the boiler shall be installed such that the gas ignition system components are protected from water (dripping, spraying, rain, etc.) during appliance operation and service (circulator replacement, control replacement, etc.).

CLEARANCES

**TABLE 1
MINIMUM CLEARANCES FROM COMBUSTIBLE SURFACES
(INDOOR ALCOVE INSTALLATIONS)**

	Boiler Size
<u>Boiler Side</u>	751, 1001, 1501
Floor	See Note 1.
Rear	1"
Right	12" (Water side)
Left	1"
Top	0"
Vent	1"

Note 1. Do not install on carpeting.

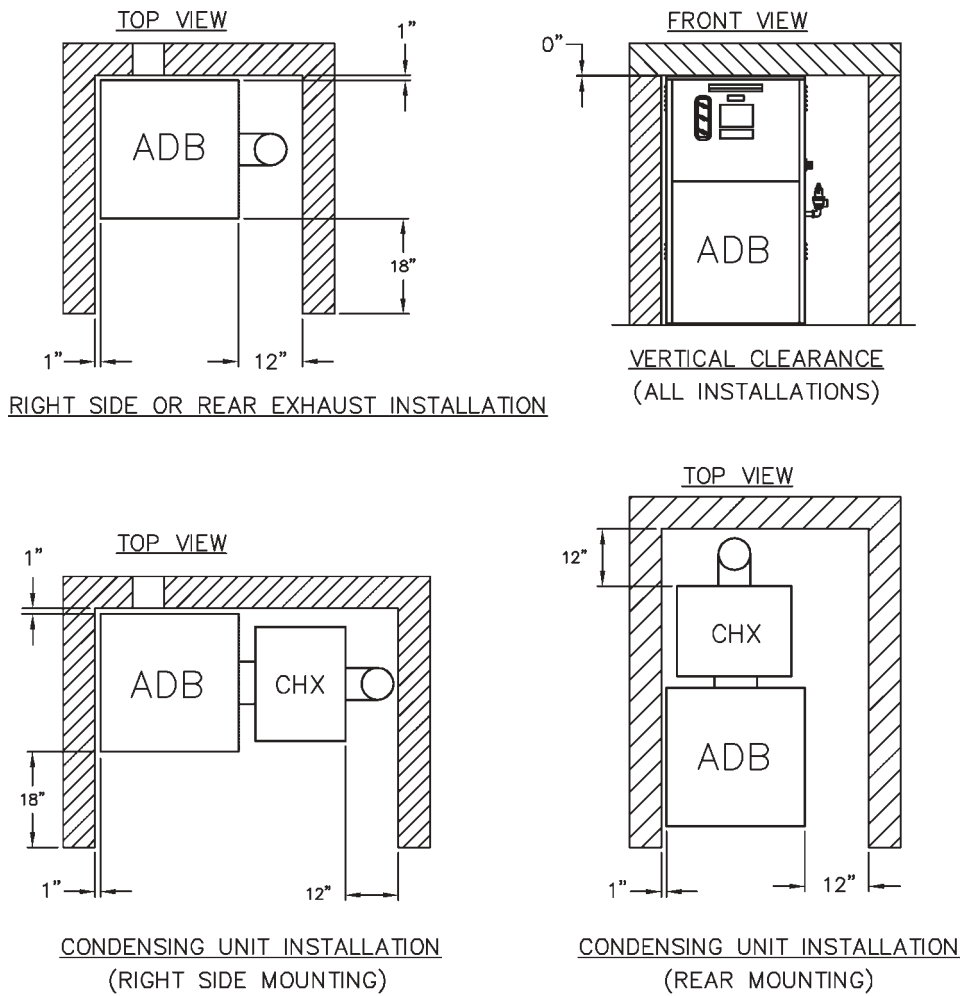

ALL CLEARANCES ARE CERTIFIED MINIMUMS AND SHOWN IN INCHES.
(24" CLEARANCES ARE REQUIRED FOR SERVICE)

FOR VENTING, SEE SECTION J

**Figure B-1
MINIMUM CLEARANCES FROM COMBUSTIBLE SURFACES AND FOR EASY SERVICING**

Raypak Advanced Design Boilers are design certified by AGA/CGA for outdoor installation. Roof water drainage must be diverted away from boilers installed under overhangs.

TABLE 2
OUTDOOR INSTALLATION MINIMUM CLEARANCES

<u>Boiler Side</u>	<u>Boiler Size</u>
Rear	751, 1001, 1501
Right	6"
Left	36" (Water side)
Top	36"
Vent	0"
	1"

WARNING: Combustion air inlet (blower air inlet) should have 6" minimum clearance from any obstruction, i.e. walls or other appliances.

SECTION C: COMBUSTION AND VENTILATION AIR

COMBUSTION AND VENTILATION AIR (Indoor Units)

The boiler must be supplied with sufficient quantities of non-contaminated air to support proper combustion and equipment ventilation. Combustion air can be supplied via conventional venting, where combustion air is drawn from the area immediately surrounding the boiler, or via direct vent, where combustion air is drawn directly from outside. All installations must comply with the requirements of NFGC for U.S., CAN/CGA B 149.1 and .2 for Canada, and all local codes.

NOTICE: “In calculating free area, the required size of openings for combustion, ventilation, and dilution air shall be based on net free area of each opening. If the free area through a design of louver or grill is known, it shall be used in calculating the size opening required to provide the free area specified”. For additional information, refer to the latest NFGC code requirements.

DIRECT COMBUSTION AIR

If outside air is drawn through a vent pipe directly to the unit for combustion:

1. Install combustion air direct vent in accordance with Section J of this manual.
2. Provide for adequate ventilation of the space occupied by the boiler(s) by an opening(s) for ventilation air at the highest practical point communicating with the outdoors. The total cross sectional area shall be at least one (1) square inch of free area per 20,000 BTUH of total input rating of all equipment in the room when the opening is communicating directly with the outdoors or through vertical duct(s). The total cross sectional area shall be at least one (1) square inch of free area per 10,000 BTUH of total input rating of all equipment in the room when the opening is communicating with the outdoors through horizontal duct(s).
3. In cold climates, and to mitigate potential freeze-up, Raypak highly recommends the installation of a motorized sealed damper to prevent the circulation of cold air through the boiler during the non-operating hours.

CAUTION: Remove the screen off the blower inlet and install a screen (1/2"-3/4" mesh) on the inlet elbow.

CONVENTIONAL COMBUSTION AIR SUPPLY (FOR U.S. INSTALLATION ONLY)

All Air from Inside the Building. If all combustion air is drawn from the air inside the building (the mechanical equipment room does not receive air from outside):

1. The mechanical equipment room must be provided with two permanent openings communicating directly with additional room(s) of sufficient volume so that the combined volume of all spaces meets the criteria for an unconfined space. (An unconfined space is defined as a space whose volume is more than 50 cubic feet per 1,000 BTUH of the aggregate input rating of all appliances installed in that space.)
2. Each opening must have a minimum free area of one (1) square inch per 1,000 BTUH of the total input rating of all gas utilization equipment in the mechanical equipment room.
3. One opening must commence within twelve (12) inches of the top, and one opening must commence within twelve (12) inches of the bottom of the room.
4. Refer to NFGC, Part 5, for additional information.

All Air from Outdoors. If all combustion air is drawn from the air outside the building (the mechanical equipment room directly communicates with the outdoors), either of the following two methods can be used:

Method 1:

1. The mechanical equipment room must be provided with two permanent openings, one commencing within (twelve) 12 inches of the top, and one commencing within twelve (12) inches of the bottom of the room.
2. The openings must communicate directly, or by ducts, with the outdoors.
3. Each opening must have a minimum free area of one (1) square inch per 4,000 BTUH of total input rating of all equipment in the room when the opening is communicating directly with the outdoors or through vertical ducts. The minimum free area required for horizontal ducts is one (1) square inch per 2,000 BTUH of total input rating to all the equipment in the room.
4. Refer to NFGC, Part 5, for additional information.

Refer to Appendix A for additional information about combustion air quality.

Method 2 (normally applied in cold climate regions):

1. The mechanical equipment room must be provided with at least one permanent opening, commencing within 12 inches of the top of the enclosure.
2. The opening must communicate directly or by ducts with outdoors.
3. The opening must have a minimum free area of 1 sq. in per 3000 BTUH of the total input rating of all equipment in the room, or no less than the sum of the areas of all vent connectors in the confined space.
- . Refer to the latest version of NFGC, part 5 for additional information.

WARNING: Do not use one permanent opening method (Method 2) if the equipment room is under negative pressure condition or the equipment is common vented with other gas-fired appliances.

COMBUSTION AND VENTILATION AIR SUPPLY (FOR CANADA INSTALLATION)

CAUTION: All combustion air has to be drawn from the air outside the building (the mechanical equipment room directly communicates with the outdoors).

1. Ventilation of the space occupied by the boiler shall be provided by an opening(s) for ventilation air at the highest practical point communicating with outdoors. The total cross-sectional area of such an opening(s) shall be at least 10% of the area required in (2) and (3), but in no case shall the cross-sectional area be less than 10 square inches (6500 square mm).
2. When air supply is provided by natural air flow from the outdoors for natural draft, partial fan assisted, fan-assisted or power draft-assisted burners, there shall be a permanent air supply opening(s) having a cross section area of not less than 1 sq. in. per 7000 BTUH (310 sq. mm per kW) up to and including 1 million BTUH, plus 1 sq. in. per 14000 BTUH (155 sq. mm per kW) in excess of 1 million BTUH. This opening(s) shall be either located at or ducted to a point neither more than 18 inches (450 mm) nor less than 6 inches (150 mm) above the floor level. The duct can also "Goose Neck" through the roof. The duct is preferred straight down 18" from floor, but do not place near piping. This air supply opening requirement shall be in addition to the air opening for ventilation air required in (1).
3. When air supply is provided by natural air flow from outdoors for a power burner and there is no draft regulator, draft hood or similar flue gas dilution device installed in the same space, in addition to the opening for ventilation air required in (1), there shall be a permanent air supply opening(s) having a total cross-sectional area of not less than 1 sq. in. for each 30,000 BTUH (70 sq. mm per kW) of total rated input of the burner(s), and the location of the opening(s) shall not interfere with the intended purpose of the opening(s) for ventilation air referred to (1). This opening(s) can be ducted to a point neither more than 18 inches (450 mm) nor less than 6 inches (150 mm) above the floor level. The duct can also "Goose Neck" through the roof. The duct is preferred to be straight down 18" from floor, but do not place near piping.
4. Refer to the latest version of CAN/CGA-B149.1 and B149.2 for additional information.

SECTION D: WATER PIPING - GENERAL

The boiler should be located so that any water leaks will not cause damage to the adjacent area or structures.

All units should be plumbed in accordance with the appropriate diagram from Section E, F or G or per a suitable engineered piping arrangement.

CAUTION: *This boiler requires forced water circulation when the burner is operating. See Table D-1 for minimum and maximum flow rates and water pump selection. The pump must be interlocked with the boiler to prevent boiler operation without water circulation. See Figure L-2 Wiring Diagram and Figure L-1.*

RELIEF VALVE PIPING

WARNING: *Pressure relief valve discharge piping must be piped near the floor close to a floor drain to eliminate the potential of severe burns. Do not pipe to any area where freezing could occur. Refer to local codes.*

HYDROSTATIC TEST

Unlike many other types of boilers, Raypak boilers do not require hydrostatic testing prior to being placed in operation. The heat exchanger has already been factory-tested and is rated for 150 PSI operating pressure. However, Raypak does recommend hydrostatically testing the piping connections to the boiler and the rest of the system prior to operation. This is particularly true for hydronic systems using expensive glycol-based antifreeze. Raypak recommends conducting the hydrostatic test before connecting gas piping or electrical supply.

Leaks must be repaired at once to prevent damage to the boiler. NEVER use petroleum-based stop-leak compounds.

1. Connect fill water supply. Fill boiler with water (be sure bleed valve is open). When water flows from bleed valve, shut off water. Close bleed valve. Carefully fill the rest of the system, being sure to eliminate any entrapped air by using high point vents. Close feed valve. TEST AT standard operating pressure for at least 24 hours.
2. Make sure constant gauge pressure has been maintained throughout test.
3. Check for leaks. Repair if found.

LOW TEMPERATURE SYSTEM

Boiler requires minimum inlet temperature of 105°F. Consult sections E, F or G for piping details. (For Pool temperature requirements, See Section G).

TEMPERATURE & PRESSURE GAUGE

The temperature and pressure gauge is factory-mounted in the inlet/outlet header.

Table D-1	BOILER RATE OF FLOW AND PRESSURE DROP											
	20°F ΔT		30°F ΔT		40°F ΔT		MAX FLOW			MIN FLOW		
MODEL	GPM	ΔP (ft)	GPM	ΔP (ft)	GPM	ΔP (ft)	GPM	ΔP (ft)	ΔT	GPM	ΔP (ft)	ΔT
ADB 751 w/CHX	63	5.8	42	2.9	x	x	110	17.0	11°F	32	1.8	39°F
	73	10.0	49	5.2	36	3.5	110	22.1	13°F	32	2.4	45°F
ADB 1001 w/CHX	84	11.8	56	5.6	42	3.4	110	20.0	15°F	42	3.4	46°F
	97	15.6	65	10.3	49	6.2	110	26.0	18°F	42	4.5	46°F
ADB 1501 w/CHX	126	31.2	84	15.0	63	9.0	126	31.2	20°F	63	9.0	40°F
	x	x	98	25.8	74	15.6	126	40.6	23°F	63	11.6	47°F

Delta P Should include typical piping To/From a single tank as well as bypass piping.

NOTE: GPM flow rates limited by maximum acceptable velocity through heat exchanger tubes. May be increased by 10% for closed heating systems. Pressure drop would increase by 21%.

SECTION E: HYDRONIC HEATING PIPING

PUMP SELECTION

In order to insure proper performance of your boiler system, you must install a properly sized pump. Raypak recommends using a 20°F Delta T as design Delta T. (Delta T is the temperature difference between the inlet and outlet water when the boiler is firing at full rate). If a Delta T larger than 20°F is necessary, the bypass must be installed and adjusted to insure proper hydraulics through the boiler while still allowing minimum flow to satisfy the safety flow switch. See Table D-1 for flow rate requirements.

**PRESSURE DROP IN FEET OF HEAD
FEEDWATER REGULATOR**

Raypak recommends that a feedwater regulator be installed and set at 12 PSIG minimum pressure at the highest point of system. Install a check valve or back flow device upstream of the regulator, with a manual shut off valve as required by local codes.

PIPING - HEATING BOILERS

All high points should be vented. Purge valves and a bypass valve should be installed. A boiler installed above radiation level must be provided with a low water cutoff device. The boiler, when used in connection with a refrigeration system, must be installed so the chilled medium is piped in parallel with the boiler with appropriate valves to prevent the chilled medium from entering the boiler.

The boiler piping system of a hot water heating boiler connected to heating coils located in air handling units where they may be exposed to circulating refrigerated air, must be equipped with flow control valves or other automatic means to prevent gravity circulation of the boiler water during the cooling cycle. It is highly recommended that the piping be insulated.

AIR-SEPARATION/EXPANSION TANK

All boilers should be equipped with a properly sized expansion tank with an air separation fitting as shown in the following diagrams.

THREE-WAY VALVES

Valves designed to blend water temperatures or reduce water circulation through the boiler should not be used. Raypak heaters are high recovery low mass heaters not subject to thermal shock. Raypak offers a full line of electric sequencers that produce direct reset of boiler water temperature. Refer to the Controls Section in our Complete Catalog.

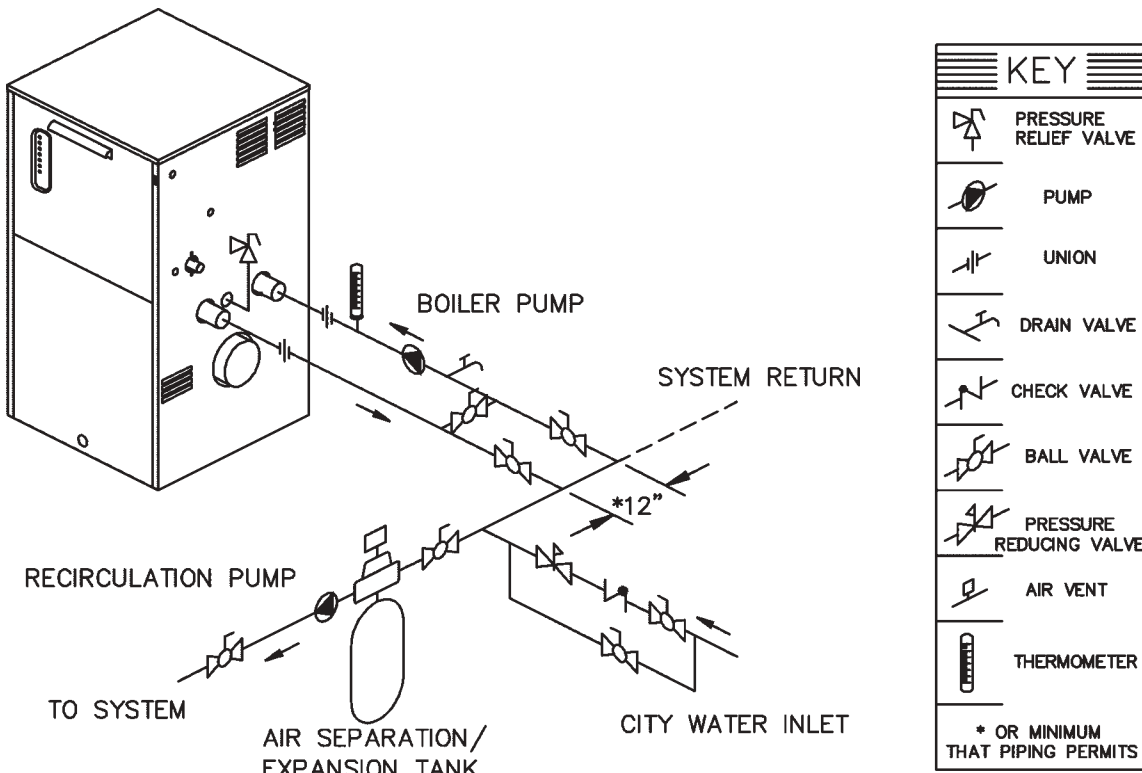

**Figure E-2a
SINGLE BOILER - PRIMARY/SECONDARY PIPING**

Figure E-2b
SINGLE BOILER - PRIMARY/SECONDARY PIPING WITH CHX

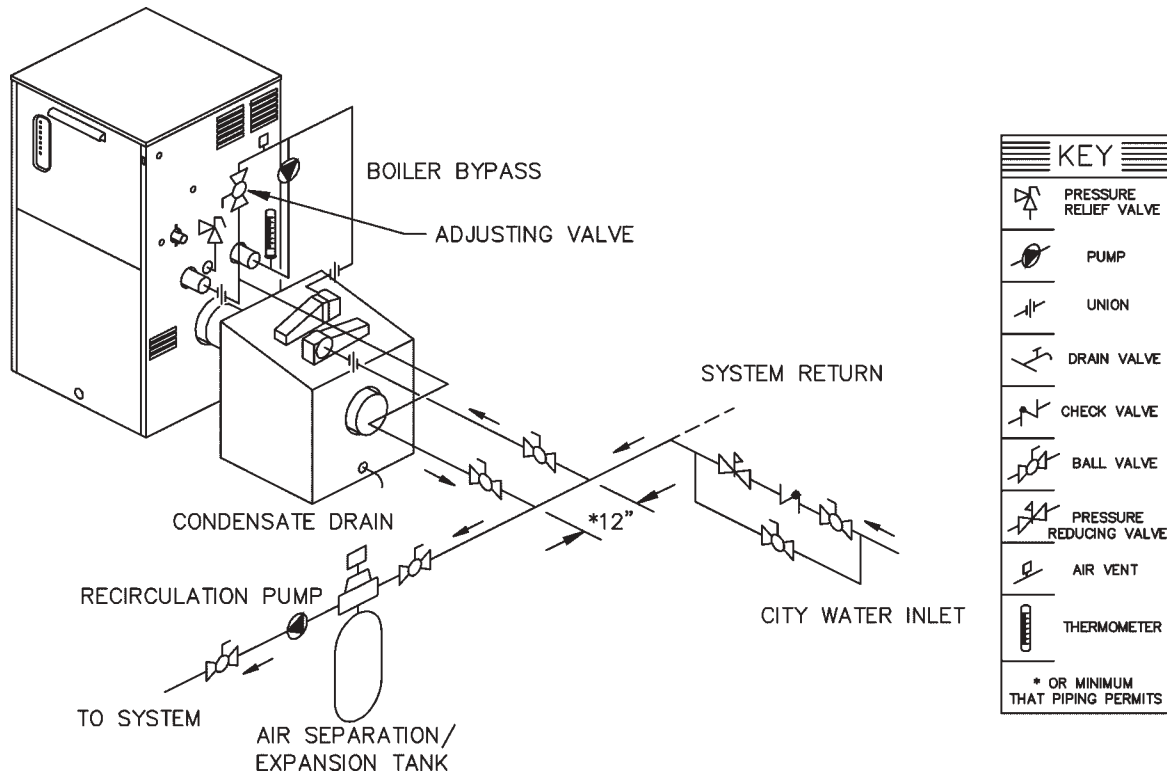

Figure E-3a
DUAL-BOILER PIPING

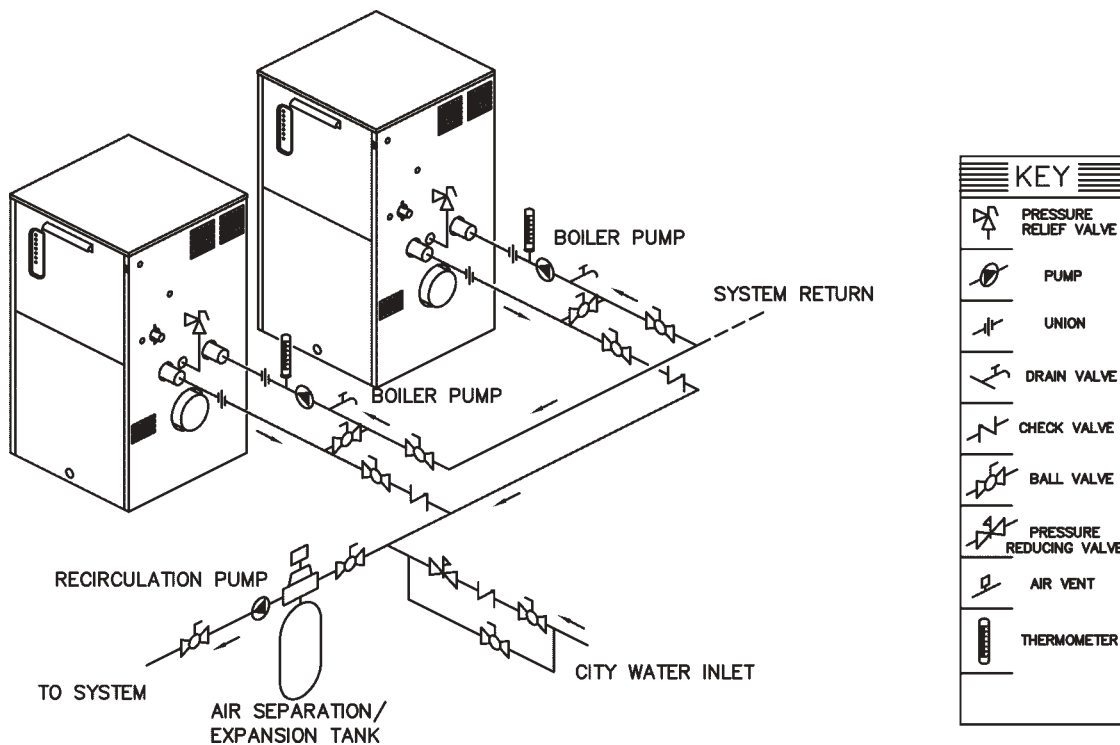
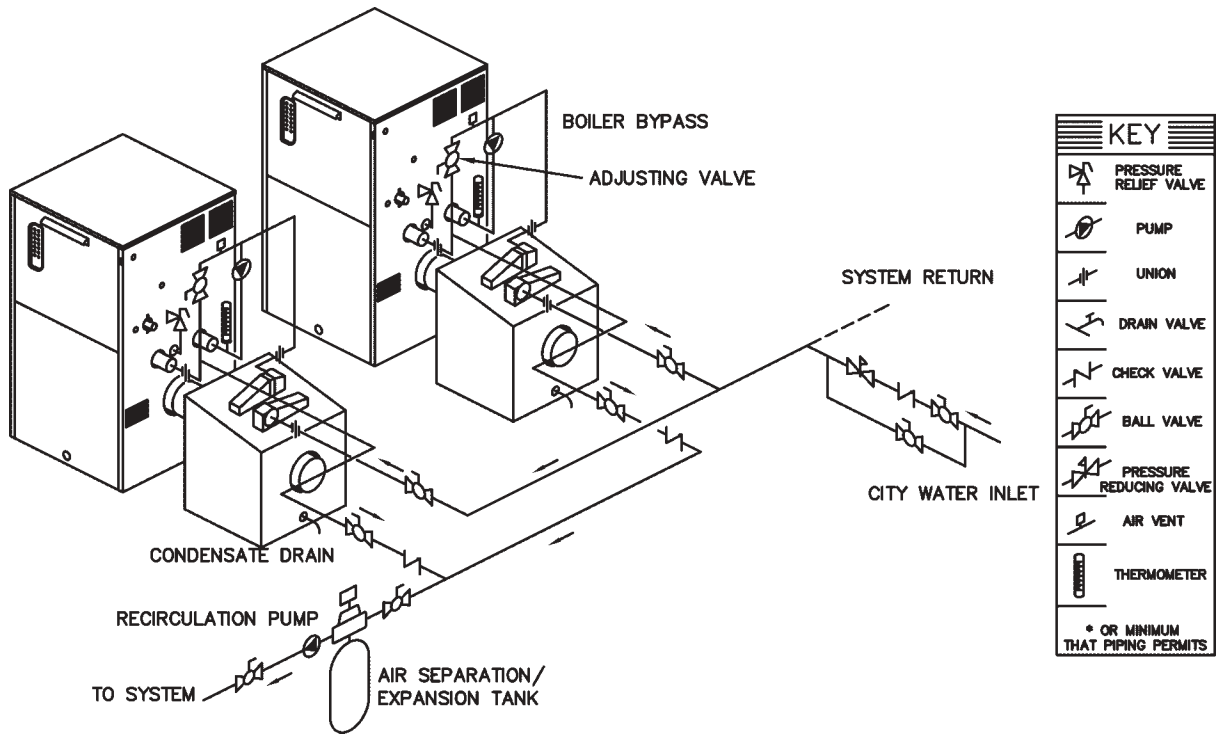
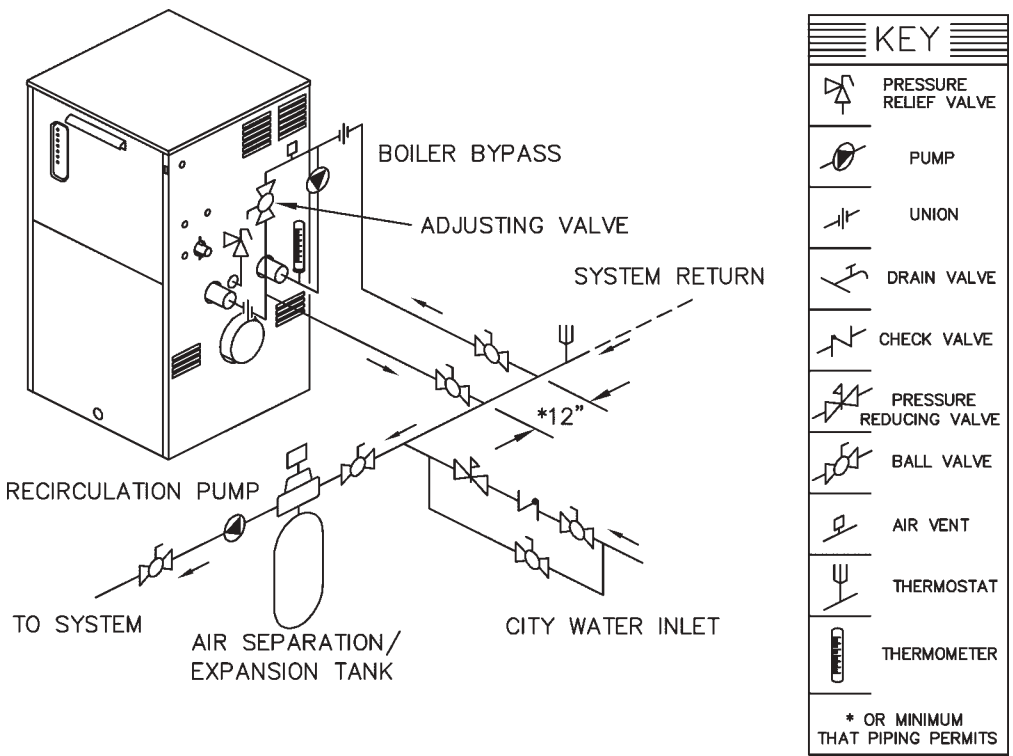

Figure E-3b
DUAL BOILER - PIPING WITH CHX



KEY	
	PRESSURE RELIEF VALVE
	PUMP
	UNION
	DRAIN VALVE
	CHECK VALVE
	BALL VALVE
	PRESSURE REDUCING VALVE
	AIR VENT
	THERMOMETER
* OR MINIMUM THAT PIPING PERMITS	

Figure E-4a
SINGLE BOILER - LOW TEMPERATURE APPLICATION (HEAT PUMP) PRIMARY/SECONDARY PIPING



KEY	
	PRESSURE RELIEF VALVE
	PUMP
	UNION
	DRAIN VALVE
	CHECK VALVE
	PRESSURE REDUCING VALVE
	BALL VALVE
	AIR VENT
	THERMOSTAT
	THERMOMETER
* OR MINIMUM THAT PIPING PERMITS	

SECTION F: DOMESTIC HOT WATER PIPING

When designing the water piping system for domestic water applications, water hardness should be considered. Table D-1 indicates the suggested flow rates for soft, medium and hard water. Hardness is specified as grains per gallon.

TABLE F-1
DOMESTIC WATER HEATING BOILER
FLOW RATE REQUIREMENTS

Model	Soft 0-4 Grains Per Gallon		Medium 5-15 Grains Per Gallon		Hard 16+ Grains Per Gallon	
	GPM	ΔT	GPM	ΔT	GPM	ΔT
ADB 751	42	30°F	63	20°F	110	11°F
w/CHX	49	30°F	73	20°F	110	13°F
ADB 1001	56	30°F	84	20°F	110	15°F
w/CHX	65	30°F	97	20°F	110	18°F
ADB 1501	84	30°F	126	20°F	126	20°F
w/CHX	98	30°F	126	23°F	126	23°F

Delta T = Temperature rise in °F

GPM = Gallons per minute

See Table D-1 for Pressure Drop

Figure F-1a

SINGLE BOILER DOMESTIC HOT WATER WITH ONE STORAGE TANK

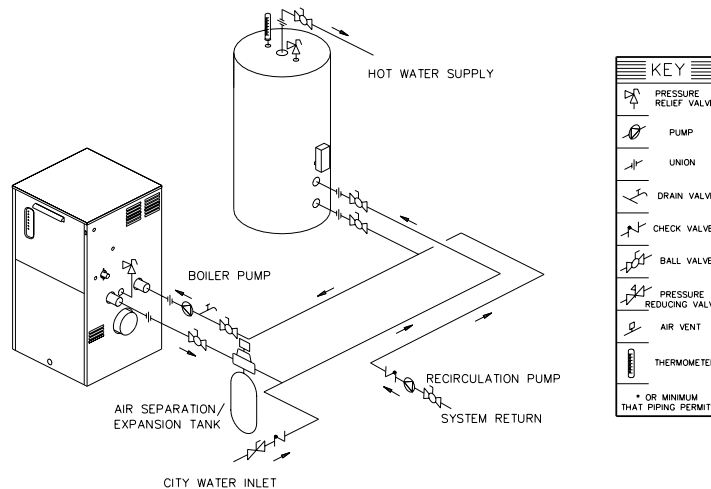

Figure F-1b

SINGLE BOILER DOMESTIC HOT WATER WITH ONE STORAGE TANK AND CHX

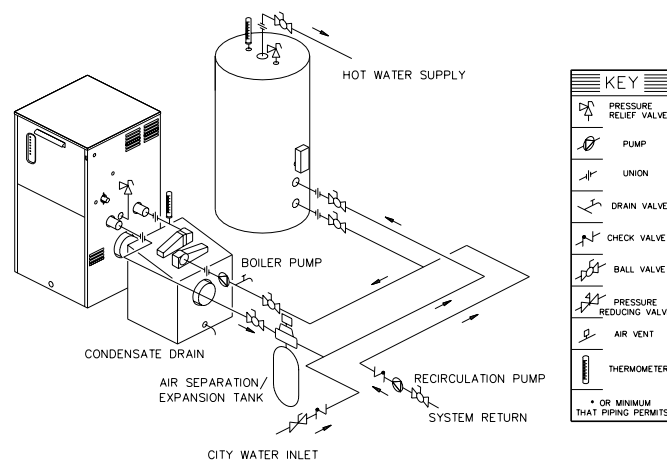

Figure F-1bb
SINGLE BOILER DOMESTIC HOT WATER WITH ONE STORAGE TANK AND CHX (2 pump system)

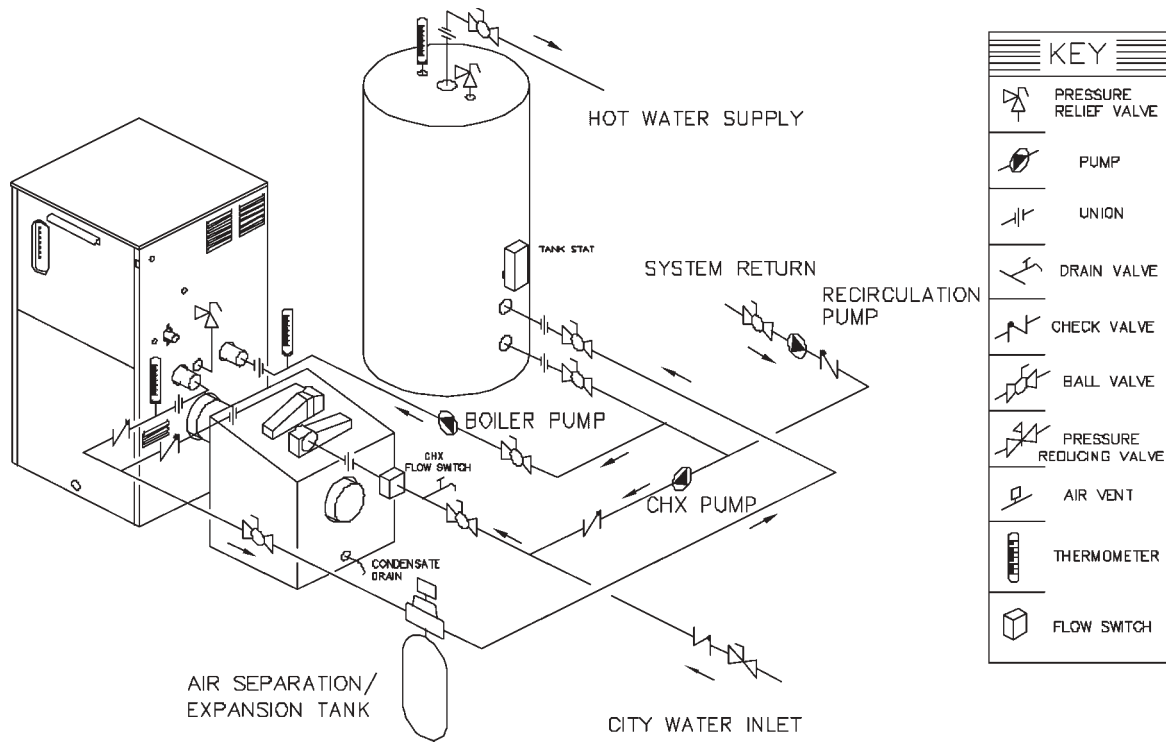
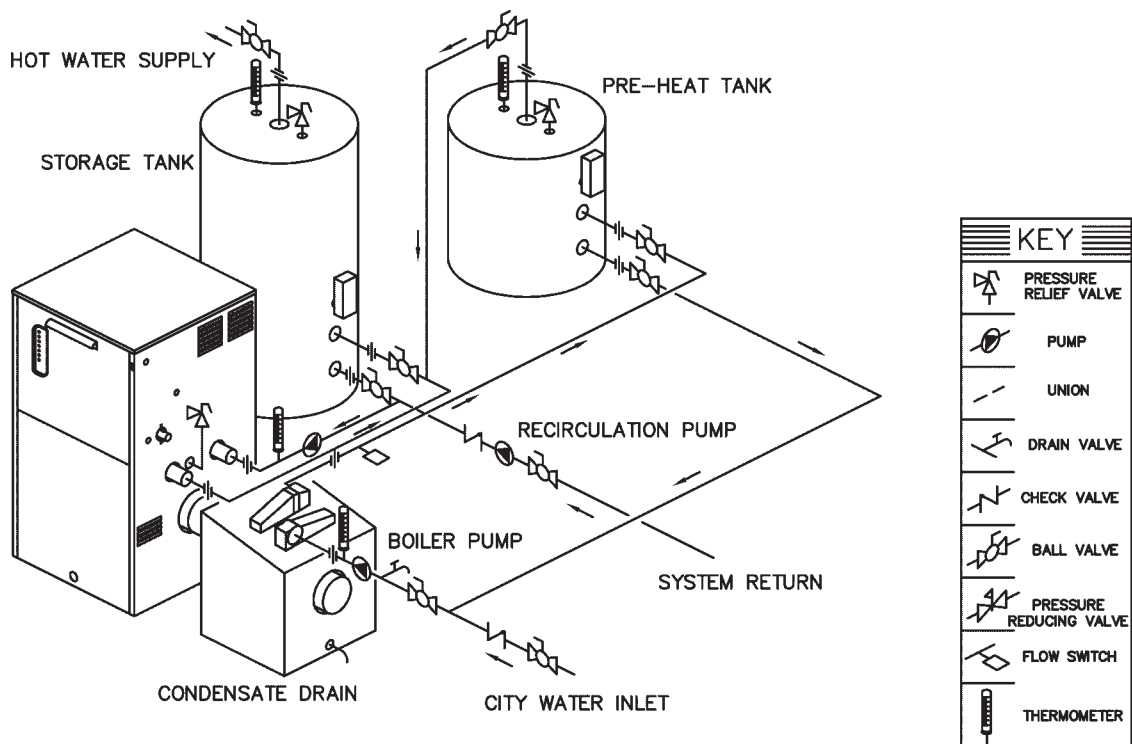

Figure F-1c
SINGLE BOILER DOMESTIC HOT WATER WITH ONE STORAGE TANK, ONE PRE-HEAT TANK AND CHX



SECTION G: POOL HEATING

CAUTION:

Power to the heater should be interlocked with the main system pump to make sure the heater does not fire without the main system pump in operation. Improper flow control can damage the heater. Uncontrolled flow (too high) or restricted flow (too low) can seriously affect heater operation. Follow these instructions to make sure your heater is properly installed.

The ADB unit is equipped with an external pump and bypass arrangement that blends outlet water with the inlet to increase the inlet water temperature, thereby reducing the likelihood of condensation forming on the heat exchanger. The pump also serves to circulate water through the heater from the main system piping.

To complete the installation of the pool heater, the pool thermostat needs to be installed in the main return water line. This will insure that the heater will be energized at the right time. If the main water line is too far away from the heater and the capillary bulb will not reach it, locate the pool thermostat adjacent to the main line and run wires back to the heater. See Figure G1-a and Figure G2-b.

Adjustment of the bypass valve is critical to proper operation of the heater. The bypass valve should be adjusted to achieve an inlet water temperature of 100°F and an outlet water temperature of 120°F. When starting with a cold pool, make initial adjustments. Make final adjustments when pool water approaches desired temperature. Refer to flow rate chart below:

Model	Loop Flow* Rate (GPM)	Heater Flow Rate (GPM)
751	30	60
1001	40	80
1501	60	120

* Loop is secondary piping to heater from main system.

AUTOMATIC CHLORINATORS AND CHEMICAL FEEDERS

All chemicals must be introduced and completely diluted into the pool or spa water before being circulated through the heater. Do not place chlorine tablets or bromine sticks in the skimmer. High chemical concentrations will result when the pump is not running (i.e. overnight).

Chlorinators must feed downstream of the heater and have an anti-siphoning device to prevent chemical backup into the heater when the pump is shut off.

NOTE: *High chemical concentrates from feeders and chlorinators that are out of adjustment will cause very rapid corrosion to the heat exchanger in the heater. Such damage is not covered under the warranty.*

WINTERIZING YOUR HEATER

When heaters installed outdoors in freezing climate areas are to be shut down for the winter, please observe the following step-by-step procedure:

1. Turn off manual main gas and main gas shut off. Remove the drain plug or open the drain valves located on the bottom header.

POOL AND SPA WATER CHEMISTRY

NOTE: Chemical imbalance can cause severe damage to your heater and associated equipment. Maintain your water pH between 7.4 and 7.8 and total alkalinity between 100 and 150 p.p.m. If the mineral content and dissolved solids in the water become too high, scale forms inside the heat exchanger tubes, reducing heater efficiency and also damaging the heater (max TDS at 3000 p.p.m.). If the pH drops below 7.2, the heater will be severely damaged.

NOTE: Heat exchanger damage resulting from chemical imbalance is not covered under the warranty.

Figure G-1a
SINGLE BOILER - POOL APPLICATION

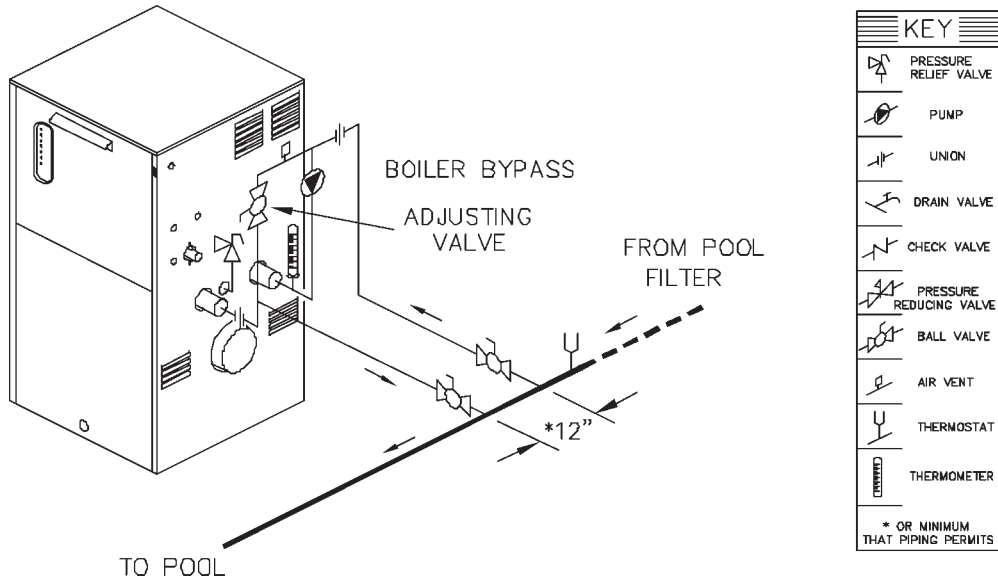

Figure G-2b
SINGLE BOILER - POOL APPLICATION WITH CHX

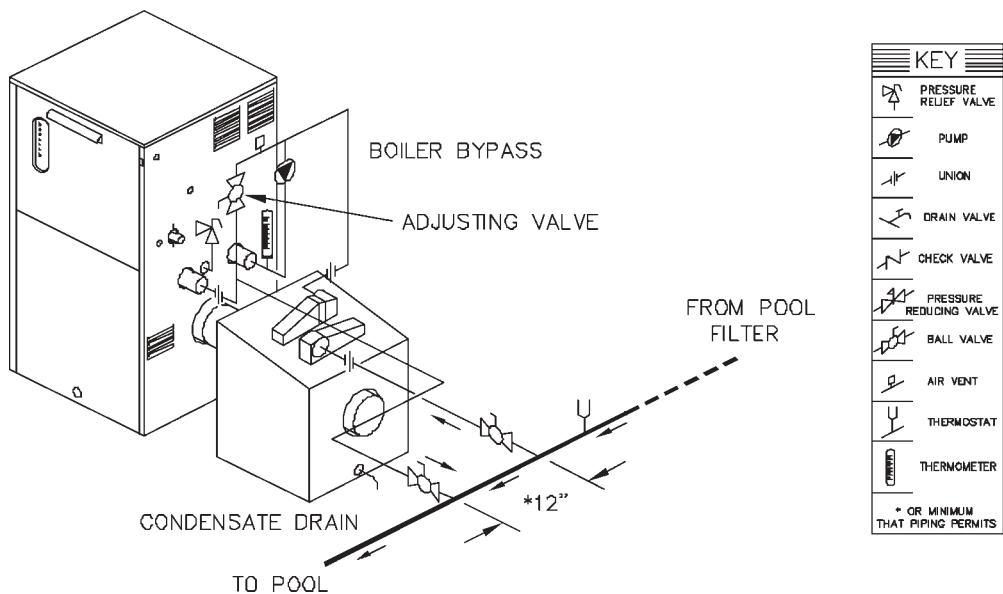
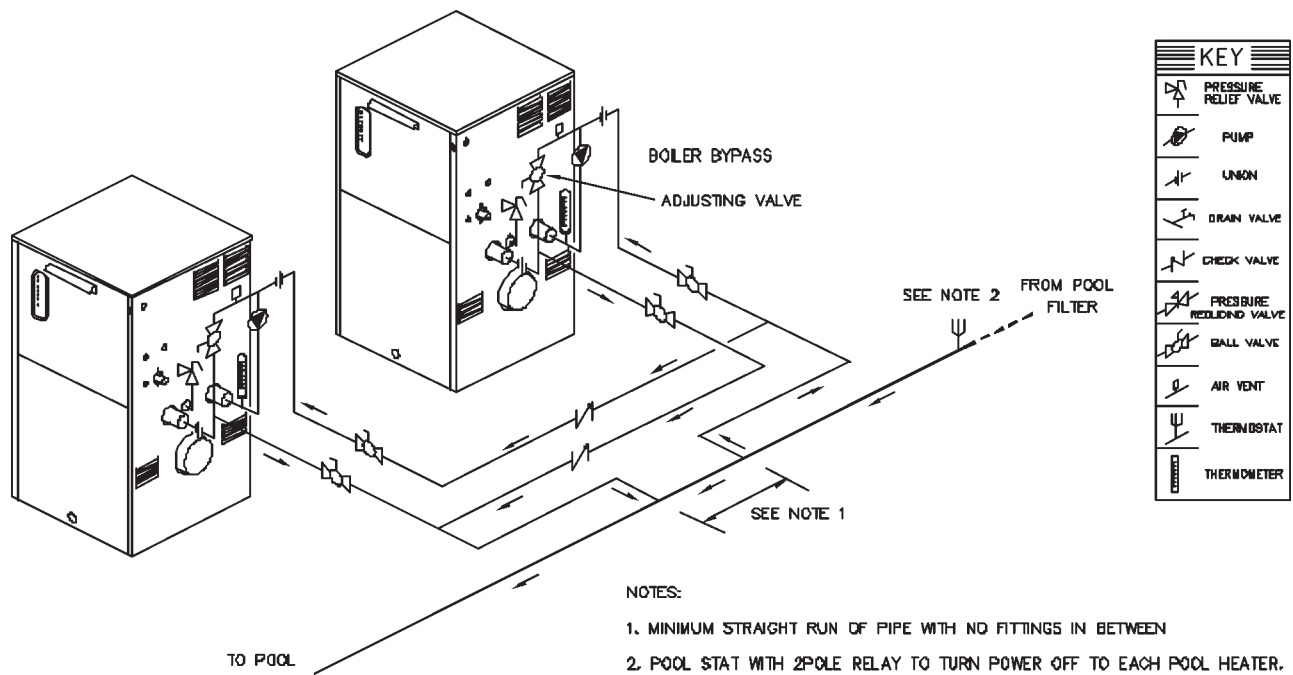

Figure G-3a
DOUBLE BOILER - POOL APPLICATION



ADB POOL SIZING: Indoor or Outdoor.

HEATER MODEL	MBTUH OUT	DESIRED TEMPERATURE RISE			
		20°F	25°F	30°F	35°F
POOL AREA IN SQUARE FEET					
P751	630	2692	2154	1795	1538
P751+CHX	735	3141	2513	2094	1795
P1001	839.5	3572	2857	2381	2041
P1001+CHX	979.5	4167	3334	2778	2381
P1501	1259.6	5384	4308	3590	3076
P1501+CHX	1469.5	6282	5026	4188	3590

This is based on average pool depth of 4' - 6" (4.5 FT)

SECTION H: GAS SUPPLY CONNECTIONS

DANGER:

Make sure the gas on which the boiler will operate is the same type as specified on the boiler model and rating plate.

Gas piping must have a sediment trap ahead of the boiler gas controls, and a manual shut-off valve located outside the heater jacket. A pounds to inches regulator must be installed to reduce to gas supply pressure to under 14" W.C. The regulator should be placed a minimum distance of 10 times the pipe diameter upstream of the boiler gas controls. All gas piping must be tested after installation in accordance with local codes. The boiler and its gas connection must be leak-tested before placing it in operation.

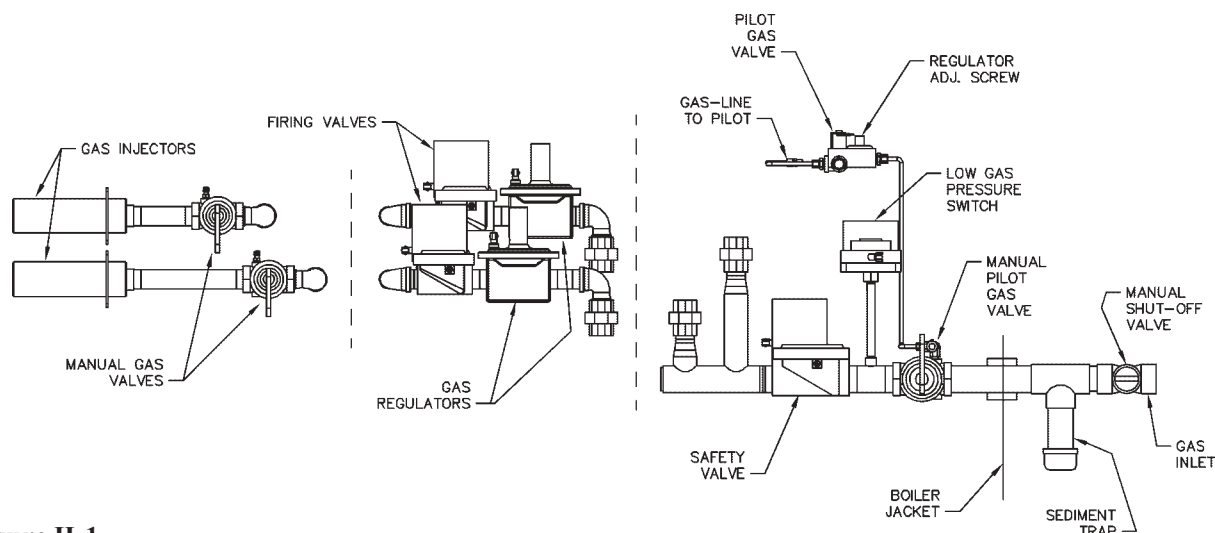

Figure H-1
GAS SUPPLY CONNECTION

The boiler and its manual shutoff valve must be disconnected from the gas supply during any pressure testing of the gas supply system at test pressures in excess of 1/2 PSIG (3.45 KPA). The boiler must be isolated from the gas supply piping system by closing the manual shutoff valve during any pressure testing of the gas supply piping system at test pressures equal to or less than 1/2 PSIG. Relieve test pressure in the gas supply line before reconnecting the boiler and its manual shut off valve to the gas supply line. **FAILURE TO FOLLOW THIS PROCEDURE MAY DAMAGE THE GAS VALVES.** Over pressurized gas valves are not covered by warranty. The boiler and its gas connections shall be leak tested before placing the appliance in operation. Use soapy water for leak test: **DO NOT** use open flame.

CAUTION:

Do not use Teflon tape on gas line pipe thread. A pipe compound rated for use with gas systems is recommended. Apply sparingly only on male pipe ends.

CAUTION:

Support gas supply piping with hangers, not by the boiler or its accessories. Ensure the gas piping is protected from physical damage and freezing where required.

GAS SUPPLY PRESSURE

A minimum of 7" W.C. and a maximum of 14" W.C. upstream gas pressure is required under load and no load conditions for natural gas. A minimum of 12" W.C. and a maximum of 14" W.C. is required for propane gas. The gas pressure regulator supplied is for low pressure service. **If upstream pressure exceeds 14" W.C, an intermediate gas pressure regulator, of the dead lockup type, must be installed.**

NOTICE:

The supply gas pressure must not fluctuate by more than +/- 1.0" WC. For fluctuating gas supply contact the factory.

When connecting additional gas utilization equipment to the gas piping system, the existing piping must be checked to determine if it has adequate capacity

MAXIMUM EQUIVALENT PIPE LENGTH
NATURAL GAS 1000 BTU/FT³ .60 SPECIFIC GRAVITY @.5" W.C. PRESSURE DROP

PIPE DIAMETER	1-1/2"	2"	2-1/2"	3"
751	65	200		
1001	35	125	200	
1501	15	60	125	225

GAS PRESSURE REGULATOR

The gas pressure regulator is nominally preset to the outlet values shown in table O-2 and O-3, within \pm . 1" W.C. If an adjustment is needed, turn the adjustment screw clockwise to increase pressure or counterclockwise to lower pressure.

VENTING OF DIAPHRAGM GAS COMPONENTS

Boilers have gas train components that have diaphragms in their construction that are supplied with a bleed line connection that must be connected to the outside atmosphere as required by NFGC or (for Canada) the B149 Installation Codes and applicable provisions of local codes. Under NO circumstances shall bleed lines terminate in the gas utilization equipment flue or exhaust system.

SECTION I: ELECTRICAL POWER CONNECTIONS

Installations must follow these codes:

- National Electrical Code and any other national, state, provincial or local codes or regulations having jurisdiction.
- Safety wiring must be N.E.C. Class 1.
- Boiler must be electrically grounded as required by N.E.C. ANSI/NFPA 70-latest edition.
- In Canada, C.S.A. C22. 1 C.E.C. Part 1.

The boiler is wired for 120 Volts. The voltage is indicated on the tie-in leads. Consult the wiring diagram shipped with the boiler in the instruction packet. The “TH” leads are connected to the remote tank control stat, thermostat, or electronic boiler control as applicable. 24 Volts are supplied to this connection through the boiler transformer. **DO NOT** attach line voltage to the “TH” leads. Before starting the boiler check to insure proper voltage to the boiler and pump.

Install a separate disconnect means for each load. Use appropriate-sized wire as defined by NEC, CSA and/or local code. All primary wiring should be 125% of minimum rating.

It is strongly recommended that all individually-powered control modules and the boiler should be supplied from the same power source.

SURGE PROTECTION

Microprocessor-based and solid state controls are vulnerable to damage from voltage and amperage fluctuations in the power supply. All sensitive control components should be protected by a suitable commercial-grade surge protection device.

If any of the original wire as supplied with the boiler must be replaced, it must be replaced with 105°C wire or its equivalent.

CHECK THE POWER SOURCE

Using a volt-ohm meter (VOM), check the following voltages at the circuit breaker panel prior to connecting any equipment: Make sure proper polarity is followed and house ground is proven.

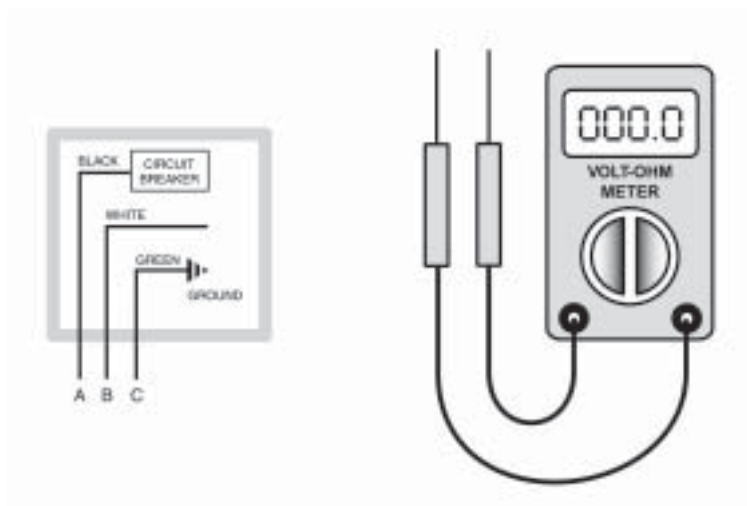

Fig # 9237

FIGURE I-1
CHECK POWER SOURCE

AC = 108 Volts AC Minimum, 132 Volts MAX
AB = 108 Volts AC Minimum, 132 Volts MAX
BC = Must be less than 1.0 Volts AC

MAKING THE ELECTRICAL CONNECTIONS

Refer to Fig. I-2 Wiring Connection, and Fig. L-2 Wiring Diagram.

1. Verify circuit breaker is properly sized by referring to boiler rating plate. A dedicated motor duty circuit breaker should be provided.
2. Turn off all power to the boiler. Verify that power has been turned off by testing with a volt-ohm meter prior to working with any electrical connections or components.
3. Observe proper wire colors while making electrical connections. Many electronic controls are polarity sensitive. Components damaged by improper electrical installation are not covered by warranty.
4. Provide an external surge suppressor capable of maintaining system integrity.
5. Provide overload protection and a disconnect means for equipment serviceability as required by local and state code.
6. Install boiler controls, thermostats, or building management systems in accordance with the applicable manufacturer's instructions.
7. Conduit should not be used as the ground. There must be a solid wired ground.

NOTICE:

A grounding electrode conductor shall be used to connect the equipment grounding conductors, the equipment enclosures, and the grounded service conductor to the grounding electrode.

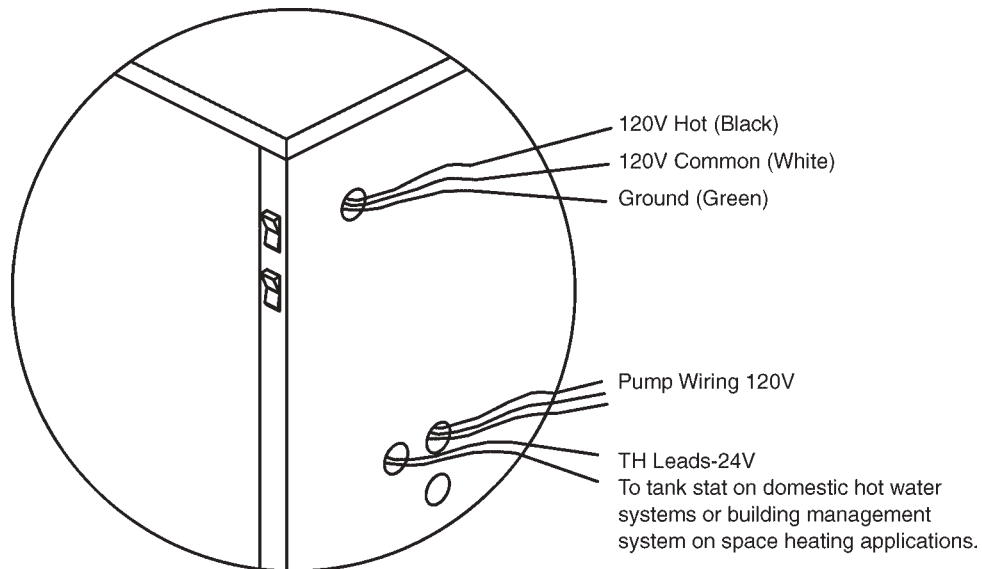

Figure I-2
FIELD WIRING CONNECTION

ELECTRICAL CONNECTIONS - DOMESTIC HOT WATER

CAUTION: Label all wires prior to disconnection when servicing controls. Wiring errors can cause improper and dangerous operation. Verify proper operation after servicing.

DANGER - SHOCK HAZARD

Make sure electrical power to the heater is disconnected to avoid potential serious injury or damage to components.

The boiler is normally wired for 120 volts. The voltage is indicated on the tie-in leads. Consult the wiring diagram shipped with the boiler in the instruction packet. The "TH" leads are for the remote tank control through the boiler transformer. DO NOT attach line voltage to the "TH" leads. Before starting boiler check to insure proper voltage to boiler and pump.

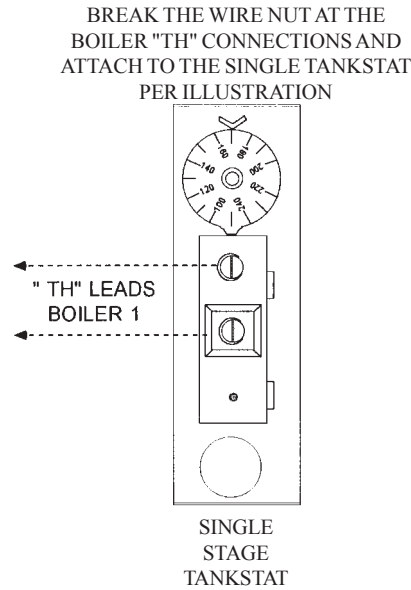

Boiler must be electrically grounded in accordance with National Electrical Code ANSI/NFPA No. 70, and CSA C22.1 C.E.C. Part 1 in Canada.

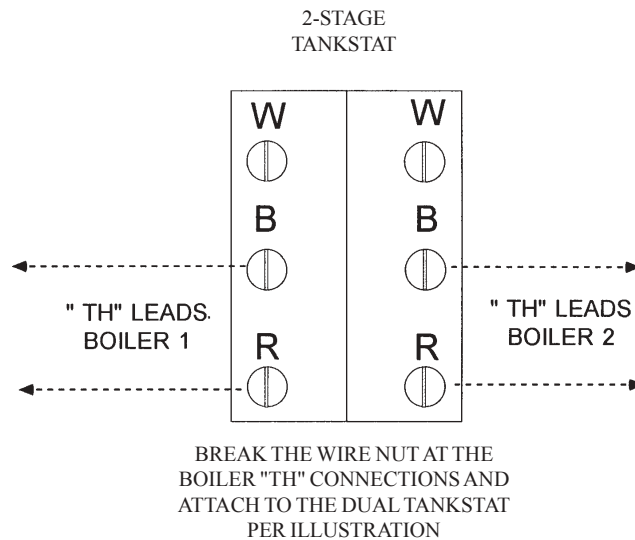

NOTES:

1. Field installed ground to inside of junction box.
2. If any of the original wire as supplied with the boiler must be replaced, it must be replaced with 105°C wire or its equivalent.

SECTION J: VENTING CONNECTIONS

GENERAL

CAUTION: *Proper installation of flue exhaust venting is critical for the safe and efficient operation of the boiler. For vent systems not shown in this section please contact your local authorized representative.*

CAUTION: *Stable vent pressure is critical to the safe and proper operation of the heater. A combination of barometric dampers, balancing dampers, extractors, or draft inducers may be required to stabilize the vent pressure.*

Definition of Appliance Categories

Boilers are divided into four categories based on the pressure produced in the exhaust and the likelihood of condensate production in the vent.

Category I. A boiler which operates with a non-positive vent static pressure and with a vent gas temperature that avoids excessive condensate production in the vent.

Category II. A boiler which operates with a non-positive vent static pressure and with a vent gas temperature that may cause excessive condensate production in the vent.

Category III. A boiler which operates with a positive vent pressure and with a vent gas temperature that avoids excessive condensate production in the vent.

Category IV. A boiler which operates with a positive vent pressure and with a vent gas temperature that may cause excessive condensate production in the vent.

See Table J-1 for vent category requirements for the Advanced Design Boiler

Note: *For additional information on appliance categorization, see appropriate ANSI Z21 Standard and the latest edition Standard of National Fuel Gas Code or in Canada, the latest edition of CGA Standard B149 Installation Code for Gas Burning Appliances and Equipment, or applicable provisions of local building codes.*

Determination of Appliance Category for Venting Purposes and Venting Arrangements

WARNING: *Contact the manufacturer of the vent material if there is any question about the appliance categorization and suitability of a vent material for application on a Category III or IV vent system. Using improper venting materials can result in personal injury, death or property damage.*

A D B V E N T I N G A R R A N G E M E N T S	HEAT EXCHANGER OPTIONS	COMBUSTION AIR SUPPLY	EXHAUST CONFIGURATION	APPLIANCE CATEGORY	CERTIFIED VENTING MATERIALS	COMBUSTION AIR INLET MATERIAL
	Without ADD-ON CONDENSING HEAT EXCHANGER (CHX)	From Inside Building (Non-Direct Venting)	Vertical Natural Draft Venting (See Section J-1)	I	Type B or Equivalent	
			Horizontal Thru-Wall Venting (See Section J-2)	III	Stainless Steel (Gas Tight)	
		From Outside Building (Direct Venting)	Vertical Venting (See Section J-4)	I	Type B or Equivalent	Galvanized Steel PVC ABS CPVC
			Horizontal Thru-Wall Venting (See Section J-3)	III	Stainless Steel (Gas Tight)	
	With ADD-ON CONDENSING HEAT EXCHANGER (CHX)	From Inside Building (Non-Direct Venting)	Vertical Venting (See Section J-5)	IV	UL 17-38 Certified Venting Material (e.g. AL 29-4C) Gas Tight	
			Horizontal Thru-Wall Venting (See Section J-6)	IV	UL 17-38 Certified Venting Material (e.g. AL 29-4C) Gas Tight	
		From Outside Building (Direct Venting)	Vertical Venting (See Section J-8)	IV	UL 17-38 Certified Venting Material (e.g. AL 29-4C) Gas Tight	Galvanized Steel PVC ABS CPVC
			Horizontal Thru-Wall Venting (See Section J-7)	IV	UL 17-38 Certified Venting Material (e.g. AL 29-4C) Gas Tight	

Table J-1 ADB Category Determination for Venting Purpose and Venting Arrangement

NOTE: PVC or CPVC vent maybe used inconjunction with CHX, special piping arrangement has to be made. Contact manufacturer for details.

Support of Vent Stack

The weight of the vent stack or chimney must not rest on the boiler vent connection. Support must be provided in compliance with applicable codes. The vent should also be supported to maintain proper clearances from combustible materials.

Use insulated vent pipe spacers where the vent passes through combustible roofs and walls.

Vent Terminal Location

NOTICE: *During winter months check the vent cap and make sure no blockage occurs from build up of snow. Condensate can freeze on the vent cap. Frozen condensate on the vent cap can result in a blocked flue condition.*

Give special attention to the location of the vent termination to avoid possibility of property damage or personal injury.

- a) Gases may form a white vapor plume in winter. The plume could obstruct a window view if the termination is installed in close proximity to windows.
- b) Prevailing winds could cause freezing of condensate and water/ice buildup on building, plants or roof.
- c) The bottom of the vent terminal and the air intake shall be located at least 12 inches above grade, including normal snow line.
- d) Un-insulated single-wall metal vent pipe shall not be used outdoors on cold climates for venting gas utilization equipment.
- e) Through-the-wall vents for Category II and IV appliances and non-categorized condensing appliances shall not terminate over public walkways or over an area where condensate or vapor could create a nuisance or hazard or could be detrimental to the operation of regulators, relief valves, or other equipment. Where local experience indicates that condensate is a problem with Category I and III appliances, this provision shall also apply.
- f) Locate and guard vent termination to prevent accidental contact by people and pets.
- g) **DO NOT** terminate vent in window well, stairwell, alcove, courtyard or other recessed area, unless previously approved by local authority.
- h) **DO NOT** terminate above any door, window, or gravity air intake. Condensate can freeze causing ice formations.
- i) Locate or guard vent to prevent condensate from damaging exterior finishes. Use a 2' x 2' rust resistant sheet metal backing plate against brick or masonry surfaces.
- j) **DO NOT** extend exposed vent pipe outside of building. Condensate could freeze and block vent pipe.
- k) Multiple direct vent caps, when installed in the same horizontal plane, should have a three (3) foot clearance from the side of one vent cap to the side of the adjacent vent cap(s).

U.S. Installations- Refer to latest edition of the National Fuel Gas Code.

Vent termination requirements are as follows:

- a) Vent must terminate at least four (4) feet below, four (4) feet horizontally, or one (1) foot above any door, window or gravity air inlet to the building.
- b) The vent must not be less than seven (7) feet above grade when located adjacent to public walkways.
- c) Terminate vent at least three (3) feet above any forced air inlet located within ten (10) feet.
- d) Vent must terminate at least four (4) feet horizontally, and in no case above or below unless four (4) feet horizontal distance is maintained, from electric meters, gas meters, regulators, and relief equipment.
- e) Terminate vent at least six (6) feet away from adjacent walls.
- f) **DO NOT** terminate vent closer than five (5) feet below roof overhang.

Canada Installations- Refer to the latest edition of CAN/CGA-B149.1 and B149.2

A vent shall not terminate:

- a) Directly above a paved sidewalk or driveway which is located between two single family dwellings and serves both dwellings.
- b) Less than 7 ft. (2.13m) above a paved sidewalk or paved driveway located on public property.
- c) Within 6 ft. (1.8m) of a mechanical air supply inlet to any building.
- d) Above a meter/regulator assembly within 3 ft. (900mm) horizontally of the vertical center-line of the regulator.
- e) Within 6 ft. (1.8m) if any gas service regulator vent outlet.
- f) Less than 1 ft. (300mm) above grade level.
- g) Within 3 ft (1m) of a window or door which can be opened in any building, any non-mechanical air supply inlet to any building to the combustion air inlet of any other appliance.
- h) Underneath a verandah, porch or deck, unless:
 - (i) the verandah, porch or deck is fully open on a minimum of two sides beneath the floor, and
 - (ii) the distance between the top of the vent termination and the underside of the verandah, porch or deck is greater than 1 ft (30cm)

Venting Installation Tips

Support piping:

- horizontal runs- at least every five (5) feet.
- vertical runs - use braces:
- under or near elbows

Follow items listed below to avoid personal injury or property damage.

- Cut nonmetallic vent pipe with fine-toothed hacksaw (34 teeth per inch).
- Do not use nonmetallic vent pipe or fittings that are cracked or damaged.
- Do not use nonmetallic vent fittings if they are cut or altered.
- Do not drill holes, or use screws or rivets, in nonmetallic vent pipe or fittings.

To make metallic vent joints:

- Do not install seams of vent pipe on bottom of runs.
- 100% Seal all joints and seams with silicone sealant.

NOTICE:

For direct vent installations where the air is piped in from outside, the protective screen on the combustion air blower may be relocated to the air inlet termination elbow to act as an inlet screen.

WARNING:

Examine the venting system at least once a year. Check all joints and vent pipe connections for tightness, corrosion or deterioration.

NOTE: The words "*Flue Exhaust*", "*Flue*" and "*Exhaust Vent*" are used interchangeably.

VENTING CONFIGURATIONS

The following is a detailed explanation of each venting system WITHOUT and WITH add-on condensing heat exchanger (CHX), its installation requirements, the components used, and part numbers for each.

For boilers connected to gas vents or chimneys, vent installations shall be in accordance with Part 7, Venting of Equipment, of the latest edition of National Fuel Gas Code, or in Canada, the latest edition of CAN/CGA-B149.1 and .2 Installation Code for Gas Burning Appliances and Equipment, or applicable provisions of local building codes.

SECTION J-1

Natural Draft Vertical Venting Without Add-on Condensing Heat Exchanger (Category I)

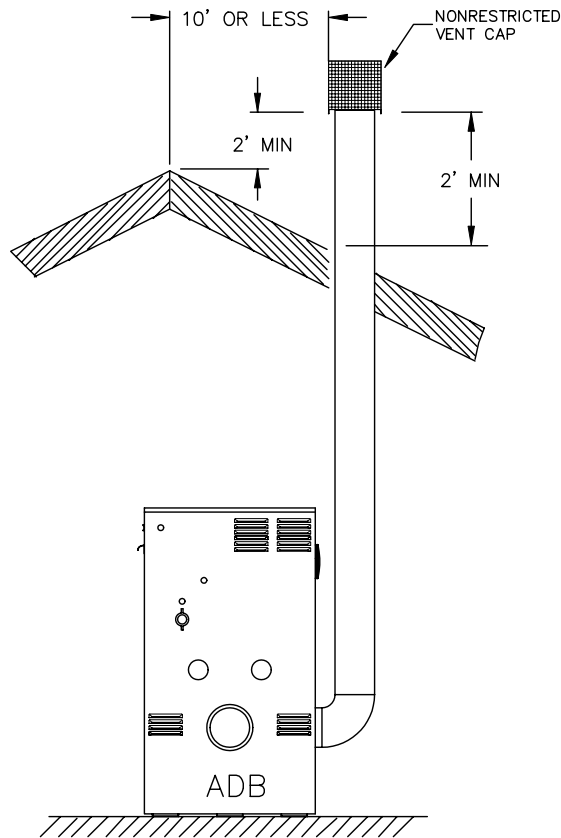

Figure J-1
NATURAL DRAFT VERTICAL VENT WITHOUT ADD-ON CONDENSING HEAT EXCHANGER*

Model	Venting Category	Certified Venting Material	Vent Size (inches)	Minimum/Maximum Venting Length (feet)
ADB-751	I	Type B or Equivalent	8	5/25
ADB-1001	I	Type B or Equivalent	10	5/25
ADB1501	I	Type B or Equivalent	12	5/25

NOTE: *Rear venting is recommended to minimize interference with water piping
 **Vent lengths are based on a lateral length of 2 feet. Refer to the latest edition of the National Fuel Gas Code for further details. (ANSI Z223.1), or in Canada the latest edition of CAN/CGA-B149.1 and B149.2.

- **Natural Draft Vertical Venting System Installation**

Natural draft venting uses the natural buoyancy of the heated flue products to create a thermal driving head that expels the exhaust gases from the flue. The negative draft must be within the range of 0.01 to 0.08” negative W.C. to insure proper operation. The vent material must be in accordance with the above instructions for vent materials. Vent material must be listed by a nationally recognized test agency.

The maximum and minimum venting length for Category I appliance shall be determined per the latest edition of the National Fuel Gas Code (U.S.) or B179.1 and .2 Installation Code (Canada).

The diameter of vent flue pipe should be sized according to Part 11 of the latest edition of the National Fuel Gas Code (U.S.) and part 7 and appendix B of the CAN/CGA-B149.1 and .2 installation code (Canada). The flue pipe diameter for conventional negative draft venting using double-wall B type vent is 8” for the ADB 751, 10” for the 1001, and 12” for the ADB 1501.

NOTICE: *Vent Adapter will have to be used to connect B vent to the unit.*

The connection from the appliance vent to the stack must be as direct as possible and shall be the same diameter as, or larger than the vent outlet. The vent must be installed to prevent accumulation of condensate and, where necessary, have means provided for drainage of condensate. The horizontal breaching of a vent must have an upward slope of not less than 1/4 inch per linear foot from the boiler to the vent terminal. The horizontal portions of the vent shall also be supported for the design and weight of the material employed to maintain clearances and to prevent physical damage or separation of joints.

- **Natural Draft Vertical Vent Termination**

The vent terminal should be vertical and should terminate outside the building at least two (2) feet above the highest point of the roof that is within 10 feet. The vent cap should have a minimum clearance of four (4) feet horizontally from and in no case above or below (unless a four (4) foot horizontal distance is maintained) electric meters, gas meters, regulators and relief equipment. The distance of the vent terminal from adjacent public walkways, adjacent buildings, open windows and building openings must be consistent with the National Fuel Gas Code, or in Canada, the latest edition of CAN/CGA-B149 Installation Code for Gas Burning Appliances and Equipment. Gas vents supported only by flashing and extended above the roof more than five feet should be securely guyed or braced to withstand snow and wind loads.

CAUTION: *Listed vent cap terminal must be used and sized adequately to evacuate the flue products from the boilers.*

- **Natural Draft Vertical Venting With Common Venting System, Category I Appliance Only
(NOT To Be Utilized With Add-on Condensing Heat Exchanger)**

Manifolds that connect more than one boiler to a common chimney must be sized to handle the combined load. Consult available guides for proper sizing of the manifold and the chimney. At no time should the area of the vent be less than the area of the largest boiler exhaust outlet.

WARNING: *Vent connectors serving appliances vented by natural draft shall not be connected into any portion of mechanical draft systems operating under a positive pressure.*

CAUTION: *Vent connectors for natural draft venting systems must be type “B” vent or better.*

Common venting systems may be too large when an existing unit is removed. At the time of removal of an existing appliance, the following steps must be followed with each appliance remaining connected to the common venting system placed in operation, while the other appliances remaining connected to the common venting system are not in operation.

- a) Seal any unused opening in the common venting system.
- b) Visually inspect the venting system for proper size and horizontal pitch and determine there is no blockage or restriction, leakage, corrosion or other unsafe condition.
- c) Insofar as is practical, close all building doors and windows and all doors between the space in which the appliances remaining connected to the common venting system are located and other spaces of the building. Turn on clothes dryers and any appliance not connected to the common vent system. Turn on any exhaust fans, such as range hoods and bathroom exhausts, so they will operate at maximum speed. Do not operate summer exhaust fan. Close fireplace dampers.
- d) Place in operation the appliances being inspected. Follow the manufacturers instructions for lighting each appliance. Adjust thermostat so appliance will operate continuously.
- e) Test for natural draft (negative pressure) 12" above the outlet elbow after 5 minutes of main burner operation. Use the flame of a match or candle, or smoke from a cigarette, cigar or pipe, toilet paper trick.
- f) After it has been determined that each appliance remaining connected to the common venting system properly vents when tested as outlined above, return doors, windows, exhaust fans, fireplace dampers and other gas burning appliances to their previous conditions of use.
- g) Any improper operation of the common venting system should be corrected so that the installation conforms with the latest edition of the National Fuel Gas Code, ANSI Z223.1, in Canada, the latest edition of CAN/CGA-B 149.1 and .2 Installation Code for Gas Burning Appliances and Equipment. When re-sizing any portion of the common venting system, the common venting system should be re-sized to approach the minimum size as determined using the appropriate tables in Appendix G in the latest edition of the National Fuel Gas Code, ANSI Z223.1, in Canada, Appendix B of the latest edition of the Installation Code for Gas Burning Appliances and Equipment.

SECTION J-2

Horizontal Thru-Wall Venting Without Add-on Condensing Heat Exchanger (Category III)

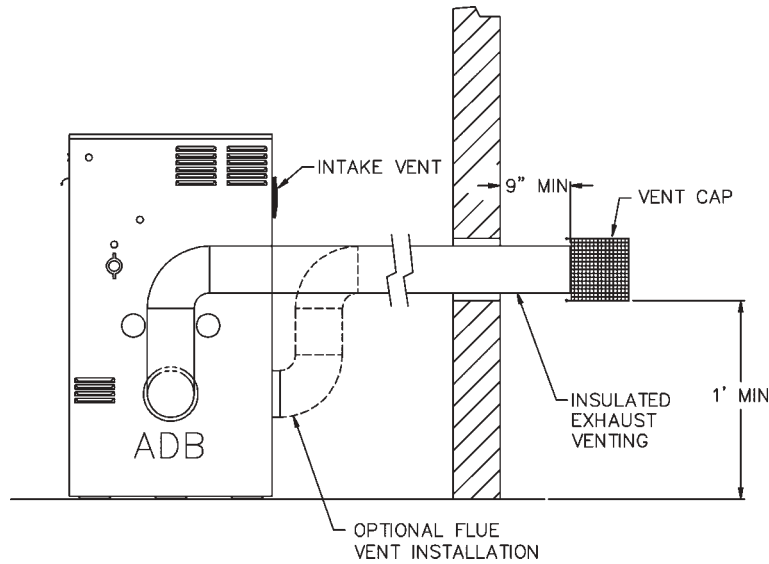

Figure J-2
HORIZONTAL THRU-WALL VENTING WITHOUT ADD-ON
CONDENSING HEAT EXCHANGER (CATEGORY III)

Model	Venting Category	Certified Venting Material	Vent Size (inches)	Maximum Venting Length (feet)
ADB-751	III	Stainless Steel (gas tight)	8	65 Subtract 10 ft per elbow, Max 3 elbows
ADB-1001	III	Stainless Steel (gas tight)	10	65 Subtract 10 ft per elbow, Max 3 elbows
ADB1501	III	Stainless Steel (gas tight)	12	65 Subtract 10 ft per elbow, Max 3 elbows

• **Horizontal Thru-wall Direct Venting System (Category III) Installation**

These installations utilize the boiler-mounted blower to vent the combustion products to the outdoors. Combustion air is taken from inside the room and the vent is installed horizontally through the wall to the outdoors. Adequate combustion and ventilation air must be supplied to the boiler room in accordance with the National Fuel Gas Code or, in Canada, the latest edition of CAN/CGA-B149.1 and .2 Installation Code for Gas Burning Appliances and Equipment.

The total length of the thru-wall exhaust vent system cannot exceed sixty-five (65) feet in length for the flue outlet. Each elbow used is equal to ten (10) feet of straight pipe. This will allow installation in one of the four following combinations.

- 65' of straight flue pipe.
- 55' of straight flue pipe and one elbow.
- 45' of straight flue pipe and two elbows.
- 35' of straight pipe and three elbows.

The direct vent cap is not considered in the overall length of the venting system.

The vent must be installed to prevent the flue gas leakage. Care must be taken during assembly to insure that all joints are sealed properly and are airtight.

The vent must be installed to prevent the potential accumulation of condensate in the vent pipes. It is recommended that:

- a) The vent be installed with a slight downward slope of not more than 1/4" per foot of horizontal run to the vent terminal.
- b) The vent be insulated through the length of the horizontal run.

For appliances installed in extreme cold climate, it is recommended that:

- a) The vent be installed with a slight upward slope of not more than 1/4" per foot of horizontal run to the vent terminal. In this case, an approved condensate trap must be installed per applicable codes.
- b) The vent be insulated through the length of the horizontal run.

- **Horizontal Thru-wall Direct Vent Termination**

The direct vent cap **MUST** be mounted on the exterior of the building. The direct vent cap cannot be installed in a well or below grade. The direct vent cap must be installed at least one (1) foot above ground level and above normal snow levels. The Raypak supplied direct vent cap must be used.

WARNING: *No substitutions of flue pipe or vent cap material are allowed. Such substitutions would jeopardize the safety and health of inhabitants.*

WARNING: *For common vent installations contact factory.*

The Stainless Steel direct vent cap must be furnished by the boiler manufacturer in accordance with its listing.

SECTION J-3

**Horizontal Thru-Wall Direct Venting/Combustion Air
(Category III)**

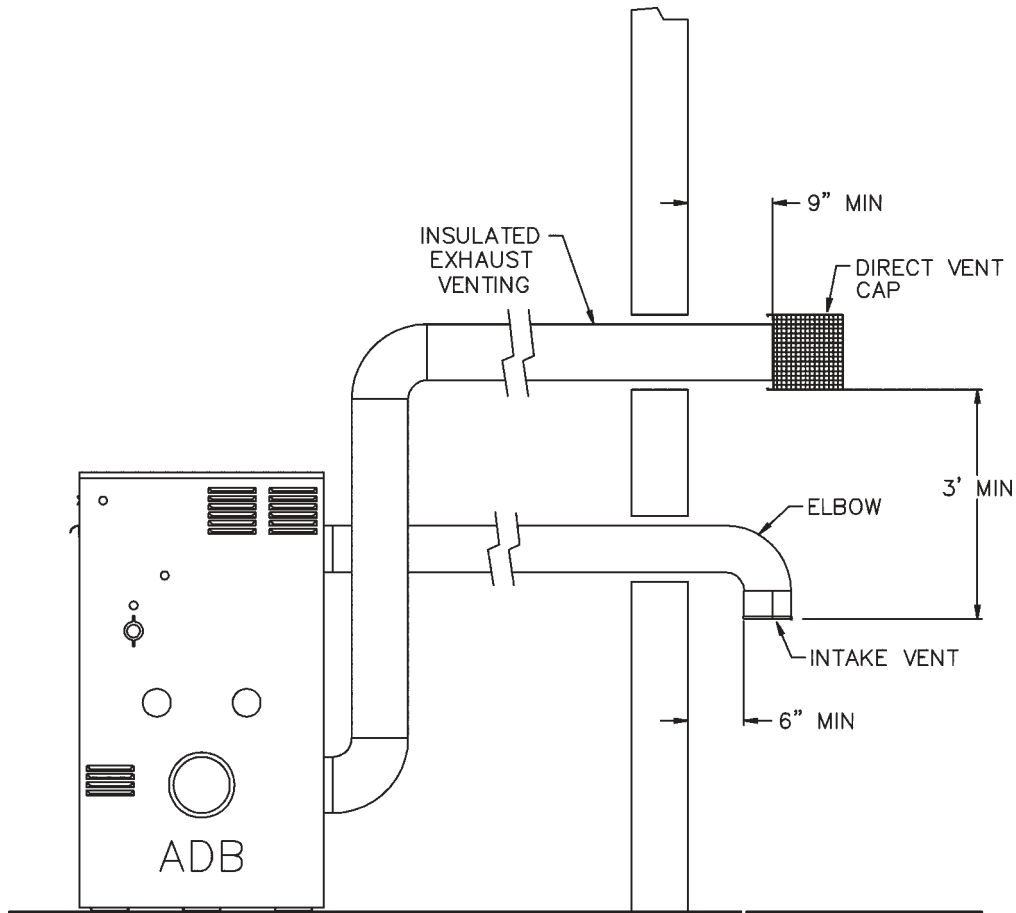

**Figure J-3
HORIZONTAL THRU-WALL DIRECT VENTING WITHOUT ADD-ON
SECONDARY CONDENSING HEAT EXCHANGER**

Model	Venting Category	Certified Venting Material	Vent Size (inches)	Maximum Venting Length (feet)	Combustion Air Intake Pipe Material	Air Inlet Size (inches)	Maximum Air Intake Length (feet)
ADB-751	III	Stainless Steel (gas tight)	8	45 Subtract 10 ft per elbow Max 3 Elbows	Galvanized Steel PVC ABS CPVC	6	45 Subtract 10 ft per elbow Max 3 Elbows
ADB-1001	III	Stainless Steel (gas tight)	10	45 Subtract 10 ft per elbow Max 3 Elbows	Galvanized Steel PVC ABS CPVC	6	45 Subtract 10 ft per elbow Max 3 Elbows
ADB1501	III	Stainless Steel (gas tight)	12	45 Subtract 10 ft per elbow Max 3 Elbows	Galvanized Steel PVC ABS CPVC	8**	45 Subtract 10 ft per elbow Max 3 Elbows

** If the boiler is direct vented, a 6" to 8" adapter must be installed at the blower inlet.

- **Horizontal Thru-wall Direct Venting System (Category III) Installation**

These installations utilize the boiler mounted blower to draw combustion air from outdoors and vent combustion products to the outdoors.

The total length of the thru-wall exhaust vent cannot exceed forty-five (45) feet in length for the flue outlet. Each elbow used is equal to ten (10) feet of straight pipe. This will allow installation in one of the three following combinations.

- 45' of straight flue pipe.
- 35' of straight flue pipe and one elbow.
- 25' of straight flue pipe and two elbows.

The total length air supply pipe cannot exceed forty-five (45) feet in length for the combustion air inlet. Each elbow used is equal to ten (10) feet of straight pipe. This will allow installation in one of the three following combinations.

- 45' of straight combustion air pipe
- 35' of straight combustion air pipe and one elbow.
- 25' of straight combustion air pipe and two elbows.

The direct vent cap is not considered in the overall length of the venting system.

Care must be taken during assembly that all joints are sealed properly and are airtight.

The vent must be installed to prevent the potential accumulation of condensate in the vent pipes. It is recommended that:

- a) The vent be installed with a slight downward slope of not more than 1/4" per foot of horizontal run to the vent terminal.
- b) The vent be insulated through the length of the horizontal run.

For appliances installed in extreme cold climate, it is recommended that:

- a) The vent be installed with a slight upward slope of not more than 1/4" per foot of horizontal run to the vent terminal. In this case, an approved condensate trap must be installed per applicable codes.
- b) The vent be insulated through the length of the horizontal run.

- **Horizontal Thru-wall Direct Vent Termination**

The direct vent cap **MUST** be mounted on the exterior of the building. The direct vent cap cannot be installed in a well or below grade. The direct vent cap must be installed at least one (1) foot above ground level and above normal snow levels.

Multiple direct vent caps **MUST NOT** be installed with one combustion air inlet directly above a direct vent cap. This vertical spacing would allow the flue products from the direct vent cap to be pulled into the combustion air intake installed above. This type of installation can cause non warrantable problems with components and poor operation of the unit due to the recirculation of flue products. Multiple direct vent caps, when installed in the same horizontal plane, should have three (3) foot clearance from the side of one vent cap to the side of the adjacent vent cap(s).

Combustion air supplied from outdoors must be free of particulate and chemical contaminants. To avoid a blocked flue condition, keep the vent cap clear of snow, ice, leaves, debris, etc.

WARNING: *For common vent installations call factory.*

WARNING: *No substitutions of flue pipe or vent cap material are allowed. Such substitutions would jeopardize the safety and health of inhabitants.*

The Stainless Steel direct vent cap must be furnished by the boiler manufacturer in accordance with its listing.

SECTION J-4

Vertical Direct Venting/Combustion Air (Category I)

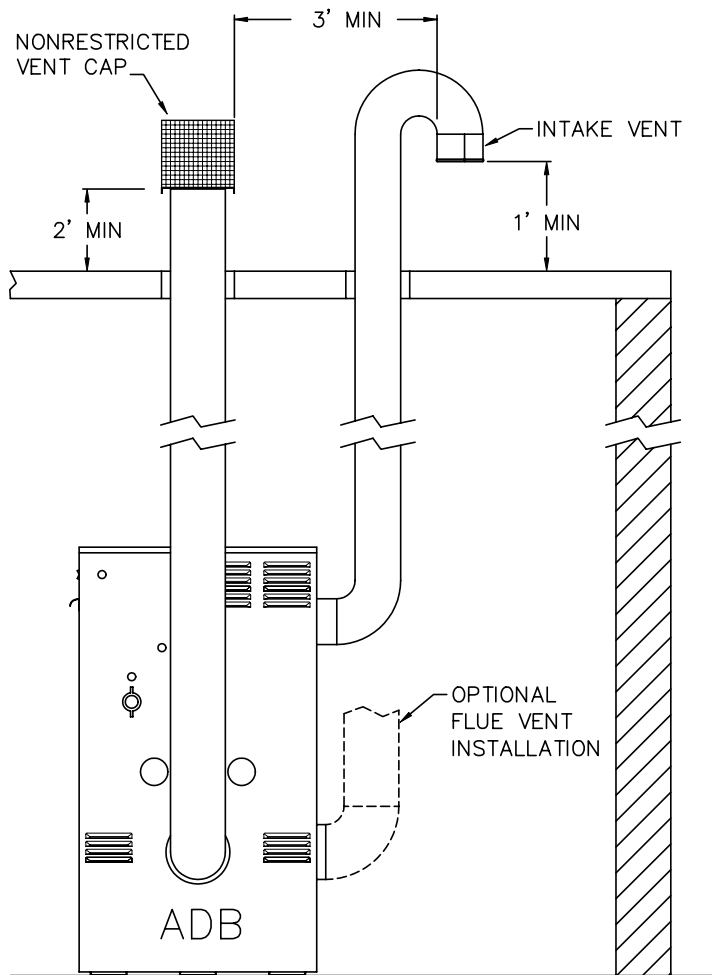

Figure J-4
VERTICAL DIRECT VENTING WITHOUT ADD-ON CONDENSING HEAT EXCHANGER

Model	Venting Category	Certified Venting Material	Vent Size (inches)	Min/Max Venting Height (feet)	Combustion Air Intake Pipe Material	Air Inlet Size (inches)	Maximum Air Intake Length (feet)
ADB-751	I	Type B or Equivalent	8	5/25	Galvanized Steel PVC ABS CPVC	6	45 Subtract 10 ft per elbow Max 3 Elbows
ADB-1001	I	Type B or Equivalent	10	5/25	Galvanized Steel PVC ABS CPVC	6	45 Subtract 10 ft per elbow Max 3 Elbows
ADB1501	I	Type B or Equivalent	12	5/25	Galvanized Steel PVC ABS CPVC	8**	45 Subtract 10 ft per elbow Max 3 Elbows

** If the boiler is direct vented, a 6" to 8" adapter must be installed at the blower inlet.

*Vent lengths are based on a lateral length of 2 feet. Refer to the latest edition of National Fuel Gas Code for further details (ANSI Z223.1) or in Canada the latest edition of CAN/CGA-B149.1 and B149.2.

- **Vertical Direct Venting System Installation**

These installations utilize the boiler mounted blower to draw combustion air from outdoors and uses the natural buoyancy of the heated flue products to create a thermal driving head that expels the exhaust gases from the flue. The negative draft must be within the range of 0.01 to 0.08” negative W.C. to insure proper operation. The vent material must be in accordance with the above instructions for vent materials. Vent material must be listed by a nationally recognized test agency.

The maximum and minimum venting length for Category I appliance shall be determined per the latest edition of the National Fuel Gas Code (U.S.) and CAN/CGA-B149.1 and .2 Installation Code (Canada).

The diameter of vent flue pipe should be sized according to part 11 of the latest edition of the National Fuel Gas Code (U.S.) and part 7 and Appendix B of CAN/CGA-B149.1 and .2 installation code (Canada). The flue pipe diameter for conventional negative draft venting using double-wall B type vent is 12” for the ADB 1500.

The connection from the appliance vent to the stack must be as direct as possible and should be the same as or larger than the vent outlet. The vent must be installed to prevent accumulation of condensate and, where necessary, have means provided for drainage of condensate. The horizontal breaching of a vent must have an upward slope of not less than 1/4 inch per linear foot from the boiler to the vent terminal. The horizontal portions of the vent shall also be supported for the design and weight of the material employed to maintain clearances and to prevent physical damage or separation of joints.

- **Vertical Direct Vent Termination**

The vent terminal should be vertical and should terminate outside the building at least two (2) feet above the highest point of the roof within 10 feet. The vent cap should have a minimum clearance of four (4) feet horizontally from and in no case above or below (unless a four (4) foot horizontal distance is maintained) electric meters, gas meters, regulators and relief equipment. The distance of the vent terminal from adjacent public walkways, adjacent buildings, open windows and building openings must be consistent with the National Fuel Gas Code, or in Canada, the latest edition of CAN/CGA-B149.1 and .2. Installation Code for Gas Burning Appliances and Equipment. Gas vents supported only by flashing and extended above the roof more than five feet should be securely guyed or braced to withstand snow and wind loads.

The vertical direct vent cap is designed for roof top mounting only. The air inlet opening MUST be installed one (1) foot above the roof line or above normal snow levels that might obstruct combustion air flow. This dimension is critical to the correct operation of the boiler and venting system and reduces the chance of blockage from snow. The vent cap must have a minimum 3 foot vertical clearance above the air inlet opening.

SECTION J-5

**Vertical Venting With Add-On Condensing Heat Exchanger
(Category IV) Domestic Water**

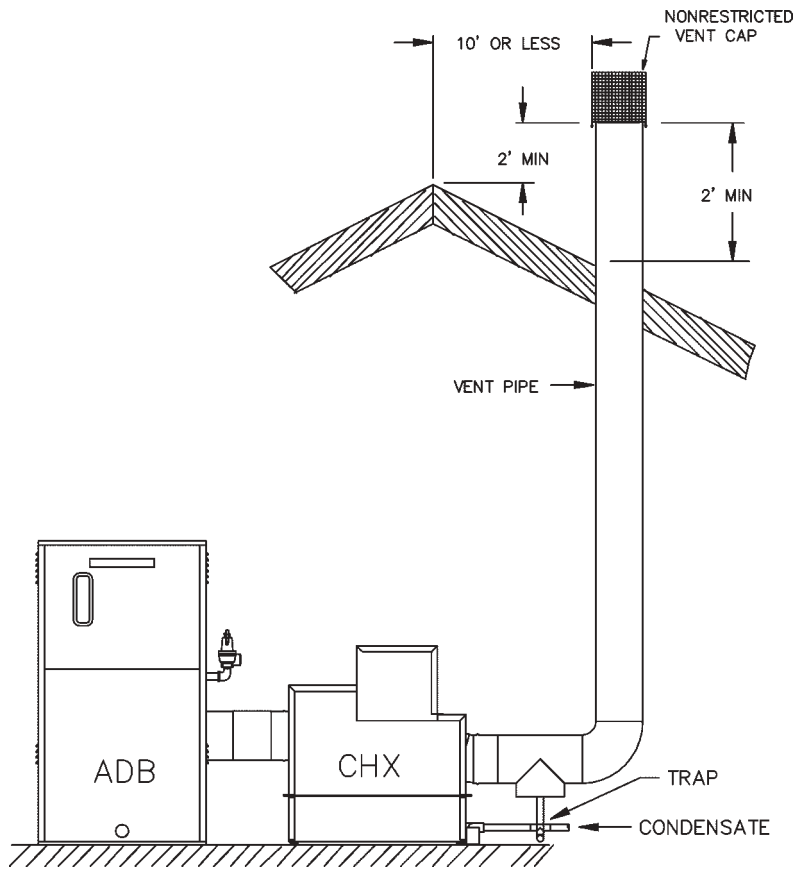

**Figure J-5
VERTICAL VENT (CATEGORY IV) WITH ADD-ON
CONDENSING HEAT EXCHANGER**

Model	Venting Category	Certified Venting Material	Vent Size (inches)	Maximum Venting Length (feet)
ADB-751 w/CHX	IV	UL 17-38 Certified Venting Material e.g. AL 29-4C Stainless Steel PVC*, CPVC*	8	55 Subtract 10 ft per elbow, Max 3 elbows
ADB-1001 w/CHX	IV	UL 17-38 Certified Venting Material e.g. AL 29-4C Stainless Steel PVC*, CPVC*	10	55 Subtract 10 ft per elbow, Max 3 elbows
ADB1501 w/CHX	IV	UL 17-38 Certified Venting Material e.g. AL 29-4C Stainless Steel PVC*, CPVC*	12	55 Subtract 10 ft per elbow, Max 3 elbows

* Contact Manufacturer for Details.

- **Vertical Vent (Category IV) with Add-on Condensing Heat Exchanger Installation**

These installations utilize the boiler mounted blower to vent the combustion products to the outdoors. Combustion air is taken from inside the room and the vent is installed vertically through the roof to the outdoors. Adequate combustion and ventilation air must be supplied to the boiler room in accordance with the National Fuel Gas Code or, in Canada, the latest edition of CAN/CGA-B149.1 AND .2. Installation Code for Gas Burning Appliances and Equipment.

UL 17-38 Certified Venting Material (e.g. AL29-4C) MUST be used. The vent must be installed to prevent the flue gas leakage. Care must be taken during assembly to insure that all joints are sealed properly and are airtight.

For certain installations, i.e. pool, heat-pump domestic hot water with pre-heat tank, PVC or CPVC may be used. Contact Manufacturer for details.

To prevent the condensation accumulation in the vent, it is required to install the horizontal portion of vent with a slight upward slope of not more than 1/4" per foot of horizontal run and an approved condensate trap must be installed per applicable codes.

WARNING: *No substitutions of flue pipe or vent cap material are allowed. Such substitutions would jeopardize the safety and health of inhabitants.*

The Stainless Steel non-restricted direct vent cap must be furnished by the boiler manufacturer in accordance with its listing.

SECTION J-6

Horizontal Thru-wall Venting With Add-on Condensing Heat Exchanger (CHX)

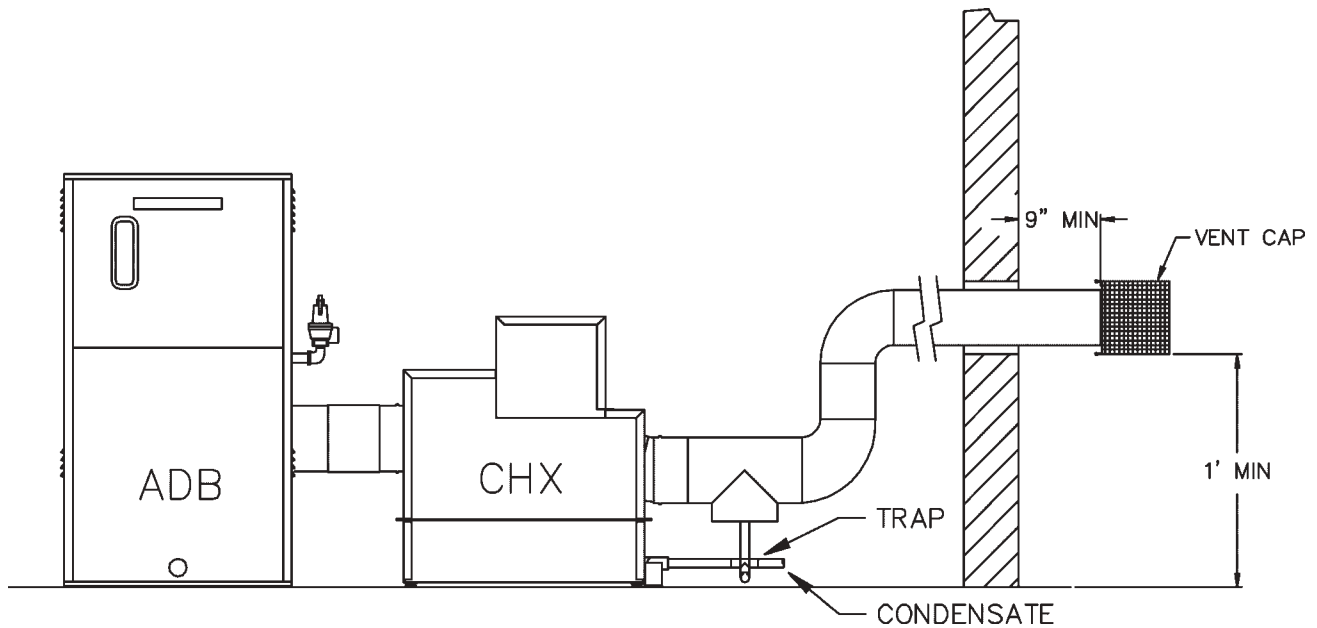

Figure J-6
HORIZONTAL THRU-WALL VENTING WITH ADD-ON
CONDENSING HEAT EXCHANGER

Model	Venting Category	Certified Venting Material	Vent Size (inches)	Maximum Venting Length (feet)
ADB-751 w/CHX	IV	UL 17-38 Certified Venting Material e.g. AL 29-4C Stainless Steel PVC*, CPVC*	8	55 Subtract 10 ft per elbow, Max 3 elbows
ADB-1001 w/CHX	IV	UL 17-38 Certified Venting Material e.g. AL 29-4C Stainless Steel PVC*, CPVC*	10	55 Subtract 10 ft per elbow, Max 3 elbows
ADB1501 w/CHX	IV	UL 17-38 Certified Venting Material e.g. AL 29-4C Stainless Steel PVC*, CPVC*	12	55 Subtract 10 ft per elbow, Max 3 elbows

* Contact Manufacturer for Details.

- **Horizontal Thru-wall Venting System (Category IV) Installation**

This installation utilize the boiler mounted blower to vent the combustion products to the outdoors. Combustion air is taken from inside the room and the vent is installed horizontally through the wall to the outdoors. Adequate combustion and ventilation air must be supplied to the boiler room in accordance with the National Fuel Gas Code or, in Canada, the latest edition of CAN/CGA-B149.1 and .2 Installation Code for Gas Burning Appliances and Equipment.

UL 17-38 Certified Venting Material (e.g. AL29-4C) MUST be used. The vent must be installed to prevent flue gas leakage. Care must be taken during assembly to insure that all joints are sealed properly and are airtight.

For certain installations, i.e. pool, heat pump, domestic hot water supply with pre-heat tank, PVC or CPVC may be used. Contact manufacturer for details.

To prevent condensate accumulation in the vent, it is required to install the horizontal portion of vent with a slight upward slope of not more than 1/4" per foot of horizontal run and an approved condensate trap must be installed per applicable codes, so the condensation in the vent pipe drains back to the boiler.

WARNING: *For common vent installations contact factory.*

WARNING: *No substitutions of flue pipe or vent cap material are allowed. Such substitutions would jeopardize the safety and health of inhabitants.*

The Stainless Steel non-restrictive direct vent cap must be furnished by the boiler manufacturer in accordance with its listing.

SECTION J-7

Horizontal Thru-Wall Direct Venting/Combustion Air With Add-On Condensing Heat Exchanger (Category IV)

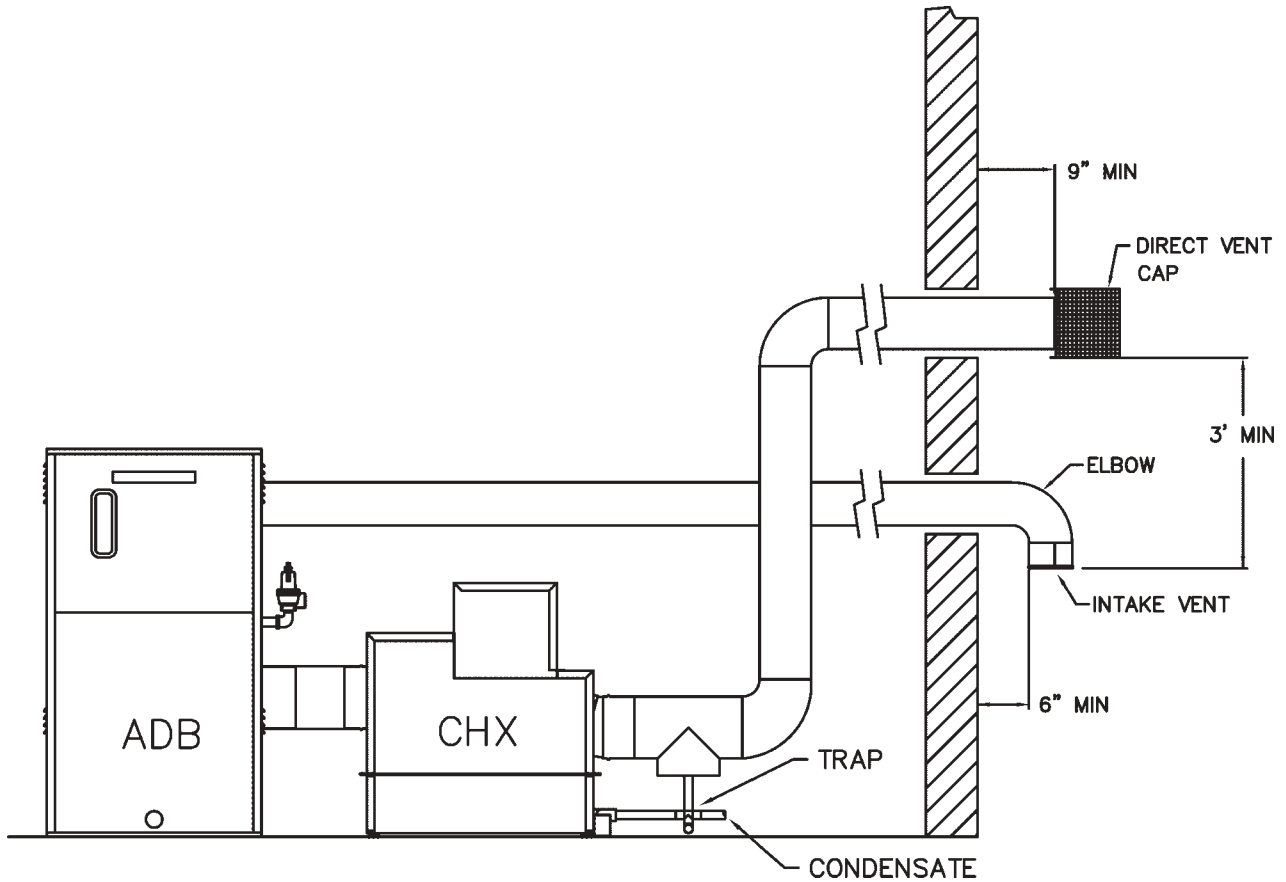

Figure J-7
HORIZONTAL THRU-WALL DIRECT VENTING WITH ADD-ON
CONDENSING HEAT EXCHANGER

Model	Venting Category	Certified Venting Material	Vent Size (inches)	Maximum Venting Length (feet)	Combustion Air Intake Pipe Material	Air Inlet Size (inches)	Maximum Air Intake Length (feet)
ADB-751 w/CHX	IV	UL 17-38 Certified Venting Material e.g. AL 29-4C Stainless Steel PVC*, CPVC*	8	35 Subtract 10 ft per elbow, Max 3 elbows	Galvanized Steel PVC ABS CPVC	6	35 Subtract 10 ft per elbow Max 3 Elbows
ADB-1001 w/CHX	IV	UL 17-38 Certified Venting Material e.g. AL 29-4C Stainless Steel PVC*, CPVC*	10	35 Subtract 10 ft per elbow, Max 3 elbows	Galvanized Steel PVC ABS CPVC	6	35 Subtract 10 ft per elbow Max 3 Elbows
ADB1501 w/CHX	IV	UL 17-38 Certified Venting Material e.g. AL 29-4C Stainless Steel PVC*, CPVC*	12	35 Subtract 10 ft per elbow, Max 3 elbows	Galvanized Steel PVC ABS CPVC	8**	35 Subtract 10 ft per elbow Max 3 Elbows

* Contact Manufacturer for Details.

** If the boiler is direct vented, a 6" to 8" adapter must be installed at the blower inlet.

- **Horizontal Thru-wall Direct Venting System With Add-on Condensing Heat Exchanger (Category IV) Installation**

These installations utilize the boiler mounted blower to draw combustion air from outdoors and vent combustion products to the outdoors.

UL 17-38 Certified Venting Material (e.g. AL29-4C) MUST be used. The vent must be installed to prevent the flue gas leakage. Care must be taken during assembly to insure that all joints are sealed properly and are airtight.

For certain installations, i.e. pool, heat-pump, domestic hot water supply with pre-heat tank, PVC or CPVC may be used. Contact manufacturer for details.

To prevent condensate accumulation in the vent, it is required to install the horizontal portion of vent with a slight upward slope of not more than 1/4" per foot of horizontal run and an approved condensate trap must be installed per applicable codes.

WARNING: *For common vent installations contact factory.*

WARNING: *No substitutions of flue pipe or vent cap material are allowed. Such substitutions would jeopardize the safety and health of inhabitants.*

The Stainless Steel non-restricted direct vent cap must be furnished by the boiler manufacturer in accordance with its listing.

SECTION J-8

Vertical Direct Venting/Combustion Air With Add-on Condensing Heat Exchanger (Category IV)

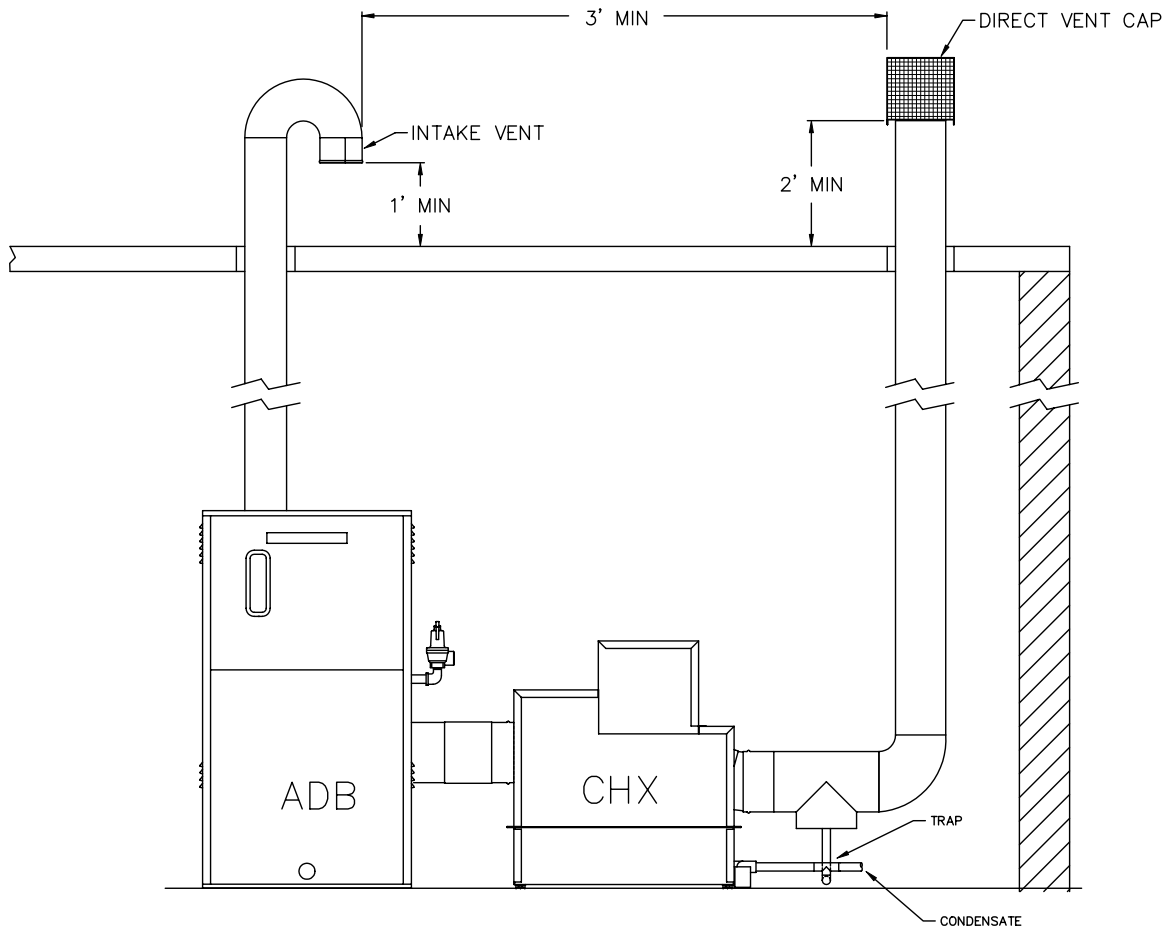

Figure J-8
VERTICAL DIRECT VENTING WITH ADD-ON
SECONDARY CONDENSING HEAT EXCHANGER

Model	Venting Category	Certified Venting Material	Vent Size (inches)	Maximum Venting Length (feet)	Combustion Air Intake Pipe Material	Air Inlet Size (inches)	Maximum Air Intake Length (feet)
ADB-751 w/CHX	IV	UL 17-38 Certified Venting Material e.g. AL 29-4C Stainless Steel PVC*, CPVC*	8	35 Subtract 10 ft per elbow, Max 3 elbows	Galvanized Steel PVC ABS CPVC	6	35 Subtract 10 ft per elbow Max 3 Elbows
ADB-1001 w/CHX	IV	UL 17-38 Certified Venting Material e.g. AL 29-4C Stainless Steel PVC*, CPVC*	10	35 Subtract 10 ft per elbow, Max 3 elbows	Galvanized Steel PVC ABS CPVC	6	35 Subtract 10 ft per elbow Max 3 Elbows
ADB1501 w/CHX	IV	UL 17-38 Certified Venting Material e.g. AL 29-4C Stainless Steel PVC*, CPVC*	12	35 Subtract 10 ft per elbow, Max 3 elbows	Galvanized Steel PVC ABS CPVC	8**	35 Subtract 10 ft per elbow Max 3 Elbows

* Contact Manufacturer for Details.

** If the boiler is direct vented, a 6" to 8" adapter must be installed at the blower inlet.

- **Vertical Direct Venting System With Add-on Condensing Heat Exchanger (Category IV) Installation**

These installations utilize the boiler mounted blower to draw combustion air from outdoors and vent combustion products to the outdoors.

UL 17-38 Certified Venting Material (e.g. AL29-4C) **MUST** be used. The vent must be installed to prevent flue gas leakage. Care must be taken during assembly to insure that all joints are sealed properly and are airtight.

For certain installations, i.e. pool, heat-pump, domestic hot water supply with pre-heat tank, PVC or CPVC may be used. Contact manufacturer for details.

To prevent the condensation accumulation in the vent, it is required to install the horizontal portion of vent with a slight upward slope of not more than 1/4" per foot of horizontal run and an approved condensate trap must be installed per applicable codes.

WARNING: *For common vent installations contact factory.*

WARNING: *No substitutions of flue pipe or vent cap material are allowed. Such substitutions would jeopardize the safety and health of inhabitants.*

The Stainless Steel non-restricted direct vent cap must be furnished by the boiler manufacturer in accordance with its listing.

Outdoor Installation with Add-On Condensing Heat Exchanger

Outdoor models are self-venting when installed with the factory-supplied non-restricted direct vent cap and require no additional vent piping. This special vent cap is provided with the boiler in accordance with AGA/CGA requirements. It must be installed directly on the boiler in a horizontal position. Notching of the vent cap mounting flange may be necessary to clear outlet piping on some models. See Section B for correct clearances.

Care must be taken when locating the outdoor unit because the flue gases discharged from the vent cap can condense as they leave the cap. Improper location can result in damage to adjacent structures or building finish. For maximum efficiency and safety, the following precautions must be observed:

- a) Outdoor models must be installed outdoors and must use the non-restricted direct vent cap supplied by the manufacturer.
- b) Periodically check venting system. The boiler's venting areas must never be obstructed in any way and minimum clearances must be observed to prevent restriction of combustion and ventilation air. Keep area clear and free of combustible and flammable materials.
- c) Do not locate adjacent to any window, door walkway, or gravity air intake. The vent should be located four (4) feet horizontally from such areas.
- d) Install above grade level and above normal snow levels.
- e) A venting system shall terminate at least 3 feet above any forced air inlet located within 10 feet.
- f) Adjacent brick or masonry surfaces must be protected with a rust-resistant sheet metal plate.
- g) Multiple Outdoor Vent installations require a four (4) feet clearance between vent caps.

NOTICE:

Condensate can freeze on the vent cap. Frozen condensate on the vent cap can result in a blocked flue condition.

The Stainless Steel non-restricted vent cap must be furnished by the boiler manufacturer in accordance with its listing.

The outdoor vent terminal must be installed in a horizontal position to prevent recirculation of flue products. The vent cap must be mounted directly on the vent pipe of the boiler.

NOTICE:

In areas of high winds (alleyways, air handlers, etc...), a downward 90° - elbow must be mounted on the combustion air inlet to prevent any air flow fluctuation.

SECTION K CONDENSATE DRAIN

WARNING: All condensation should be disposed of according to local, county, state, and federal laws. Refer to NFGC, section 7.9, for additional information.

The Condensing Heat Exchanger (CHX) can generate up to 1 (one) gallon per hour (GPH) of condensate for every 100,000 BTUH. The maximum condensation rate for the ADB 751 is 7.5 GPH, the ADB 1001 is 10 GPH, and the ADB1501 is 15 GPH.

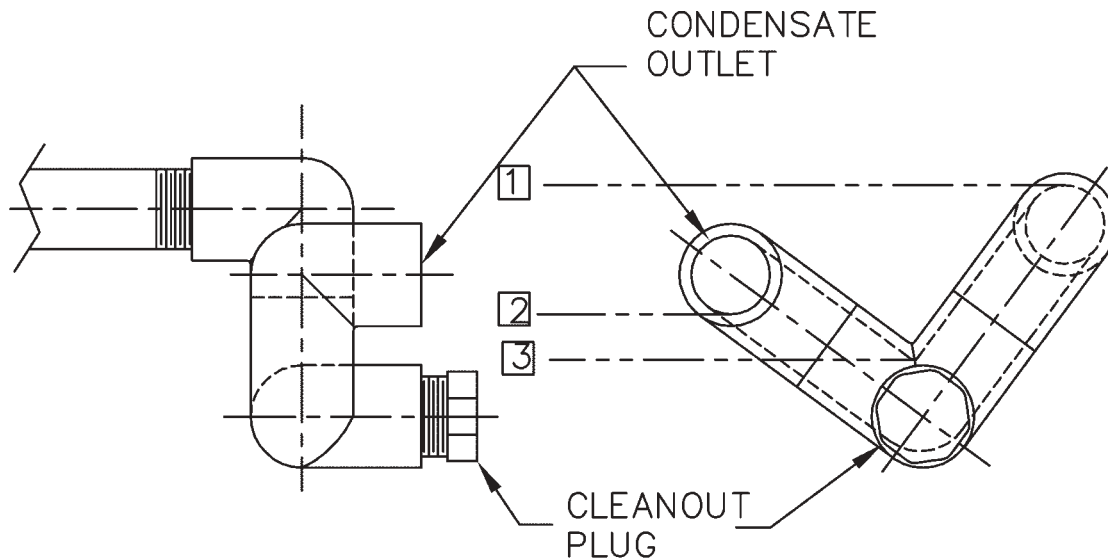

NOTE: **2** MUST ALWAYS BE BETWEEN **1** AND **3** TO PREVENT FLUE GAS CONTAMINATION AND/OR TRAPPED CONDENSATE IN CHX

Figure K-1
CONDENSATE TRAP ALIGNMENT

SECTION L CONTROLS

WARNING: *Installation, adjustment and service of boiler controls including timing of various operating functions must be performed by a qualified installer or service agency. Failure to do so may result in control damage, boiler malfunction, property damage, personal injury, or death.*

WARNING: *Turn off the power to the boiler before installation, adjustment or service of the Central Point Wiring board or any boiler controls. Failure to do so may result in board damage, boiler malfunction, property damage, personal injury, or death.*

CAUTION: *This appliance has provisions to be connected to more than one (1) supply source. To reduce the risk of electric shock, disconnect all such connections before servicing.*

CAUTION: *Risk of electric shock. More than one (1) disconnect switch may be required to de-energize the equipment before servicing.*

CENTRAL POINT WIRING (CPW)

Central Point Wiring is an advanced control integration technique that provides complete boiler diagnostic capability and greatly simplifies troubleshooting. At the heart of CPW is the Operations Status Center, which is comprised of two different circuit boards: the CPW board and one or more U-2 Diagnostic Boards.

THE CPW BOARD

The Central Point Wiring (CPW) board serves as the central tie point for connecting all other control components in the boiler. The CPW board provides boiler operating status and fault indication using eight LEDs which function as described in Table L-1

Table L-1 CPW Board LED Indicators

Light	Color	Indication
Power	Green	24 VDC is applied to the system
System Error	Red	Overload current on the board. Board is disabled.
Pump	Green	Boiler Pump is energized.
Pilot	Yellow	Power applied to the Pilot Gas Valve. (PV signal on.)
Main Gas	Green	Power applied to Main Gas Valve. (MV signal on.)
Call for Heat	Green	Thermostat is closed. Call for heat present.
Service	Red (Flashing)	One or more of the safeties are open. Refer to U-2 Board
Blower	Green	Blower is energized.

In addition to monitoring and displaying boiler status, the CPW board controls the timing of various operating functions including: boiler pump turn-off delay, blower fan pre-purge, and blower fan post-purge. The location of each user-adjustable timing is shown in Figure L-1.

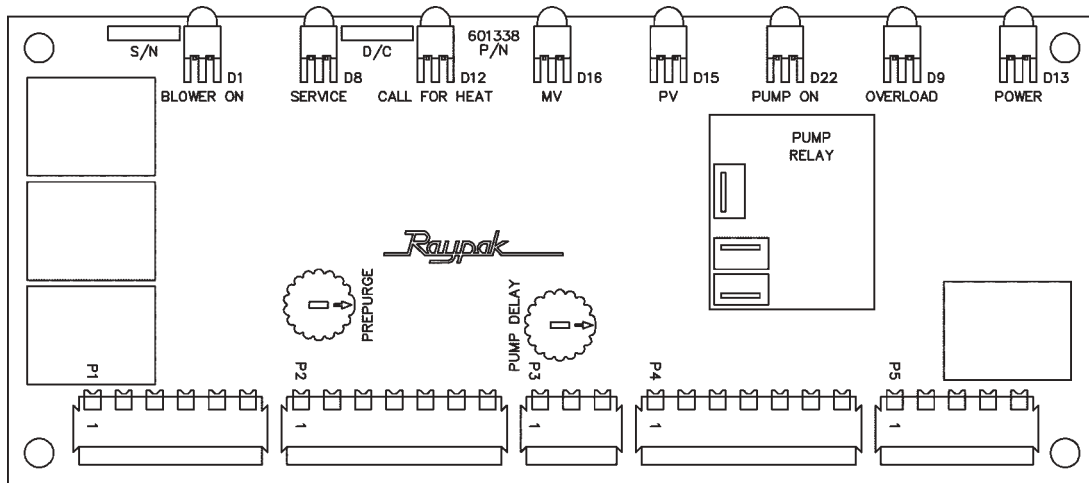

Figure L-1
CPW Board

- Pump Turn-off Delay

The CPW board has a built-in pump driver with pump turn-off delay, which allows the operator to set how long the pump will run after the boiler shuts off. The delay is factory-set for 7 minutes but can be field-adjusted from 3 minutes to 10 minutes. The pump relay can directly power a pump of up to 12.0 amps draw or 3/4 Hp capacity. Pumps with larger amp draws should be energized through a pump contactor that is controlled by the CPW board.

By properly setting the pump turn-off delay, the boiler pump will continue running for a limited period of time in order to extract any residual heat from the combustion chamber. The pump will then shut off to conserve energy until the next call for heat. The pump-off time delay should be set to the minimum time required to extract all residual heat from the heat exchanger. If temperature as monitored at the boiler outlet increases more than 5°F after the pump turns off following a firing cycle, the pump-off time delay should be extended by thirty seconds. Increase or decrease time delay as appropriate until outlet temperature does not spike more than 5°F after pump shut-off following a prolonged firing cycle (> 5min.)

CAUTION: *The boiler requires forced water circulation when the burner is operating and the pump must be interlocked with the boiler. See Section D for minimum water maximum flow rates and pump selection.*

NOTICE: *Pump will come on when power is first applied to the boiler.*

- Blower Fan Pre-purge

The CPW board has a built-in pre-purge delay which operates the blower fan for a user-adjustable time period prior to pilot trial for ignition. The pre-purge period ensures that the combustion chamber is clear of all excess combustible gases prior to commencing the pilot ignition cycle. The pre-purge delay is factory set for 45 seconds and it can be adjusted in the field from 45 seconds to 120 seconds. To optimize boiler response time on call-for-heat, set the pre-purge delay to the minimum allowed by local, state or national code.

- Blower Fan Post-purge

The CPW board has a built-in post-purge delay to exhaust residual combustion products after the main gas valve closes. The post-purge timing is factory set at 3 minutes and is not field-adjustable.

- Freeze Protection Feature

The CPW board is programmed to turn-off the blower in case there is a lock-out condition. If there is a call for heat signal, and the pilot valve signal is removed and not reactivated within a pre-set time for any reason, the CPW board will turn off the blower to prevent blowing cold air continuously and freezing the heat exchanger. The blower drives will open and the system will lock in the off state. To restart the system, primary power or the thermostat signal must be turned off and back on. The pre-set freeze protection feature time is approximately 5 minutes.

U-2 Diagnostics Board

The U-2 Diagnostics board is a solid-state electronic fault indicator that has been engineered to enhance safety, simplify troubleshooting and minimize equipment down time. The U-2 safety board is the central point for wiring, operations monitoring, and fault indication for the boiler safeties. By having each safety report directly to the U-2 board, each safety function can be individually monitored. The U-2 adds complete diagnostics features that aid in the rapid diagnosis of irregularities in boiler operation.

A single U-2 Diagnostics Board can monitor a maximum of eight safeties at one time. If, due to code requirements, more than eight safety devices must be monitored, two or more boards will be used to provide extended diagnostics capabilities. Advanced Design Boilers equipped with the standard safety suite will utilize the configuration shown in Table L-2.

Table L-2. U-2 Diagnostic Board LEDs

Light	Color	Indication
System Enabled	Yellow	U-2 Diagnostics safety board is functional.
Manual High Limit	Red	Water temperature is over the manual high limit setting.
Auto High Limit	Red	Water temperature is over the auto high limit setting.
Flow Switch	Red	Water flow rate is too low.
Low Water Cut-off (option)	Red	Insufficient water volume for boiler operation.
High/Low Gas Pressure	Red	Gas supply pressure is below or above the allowed minimum gas supply pressure to ensure safe operation.
Burner High Limit	Red	Mixer or PVC vent pipe, if installed, is over heated.
Blower/Ignition Lockout	Red	Blower failure, not enough combustion air or the equipment has an ignition lock-out condition.
Blocked Vent	Red	The vent pressure switch has detected a blocked vent.

The U-2 safety board has a series of red LED lights to indicate a fault occurring at a monitored safety. An additional light indicates that the diagnostics board is energized and is currently monitoring for safety faults. (In order to prevent spurious alarm conditions, the U-2 board monitors safeties only during the actual firing cycle.) Once a fault has been detected, the U-2 board will illuminate the corresponding LED lamp, will shut-down the boiler, and will light the flashing red LED “Service” lamp on the CPW board. If more than one fault is detected, the U-2 board will display the priority fault based on the safety hierarchy as labeled on the U-2 board. Once the first fault is cleared, the second fault lamp will illuminate until cleared.

WARNING Only qualified persons shall attempt to repair the boiler. Improper adjustment, service or maintenance may damage the equipment, create a hazard resulting in asphyxiation, explosion, fire, electric shock, personal injury or property damage, and will void the warranty.

**Figure L-2
WIRING DIAGRAM**

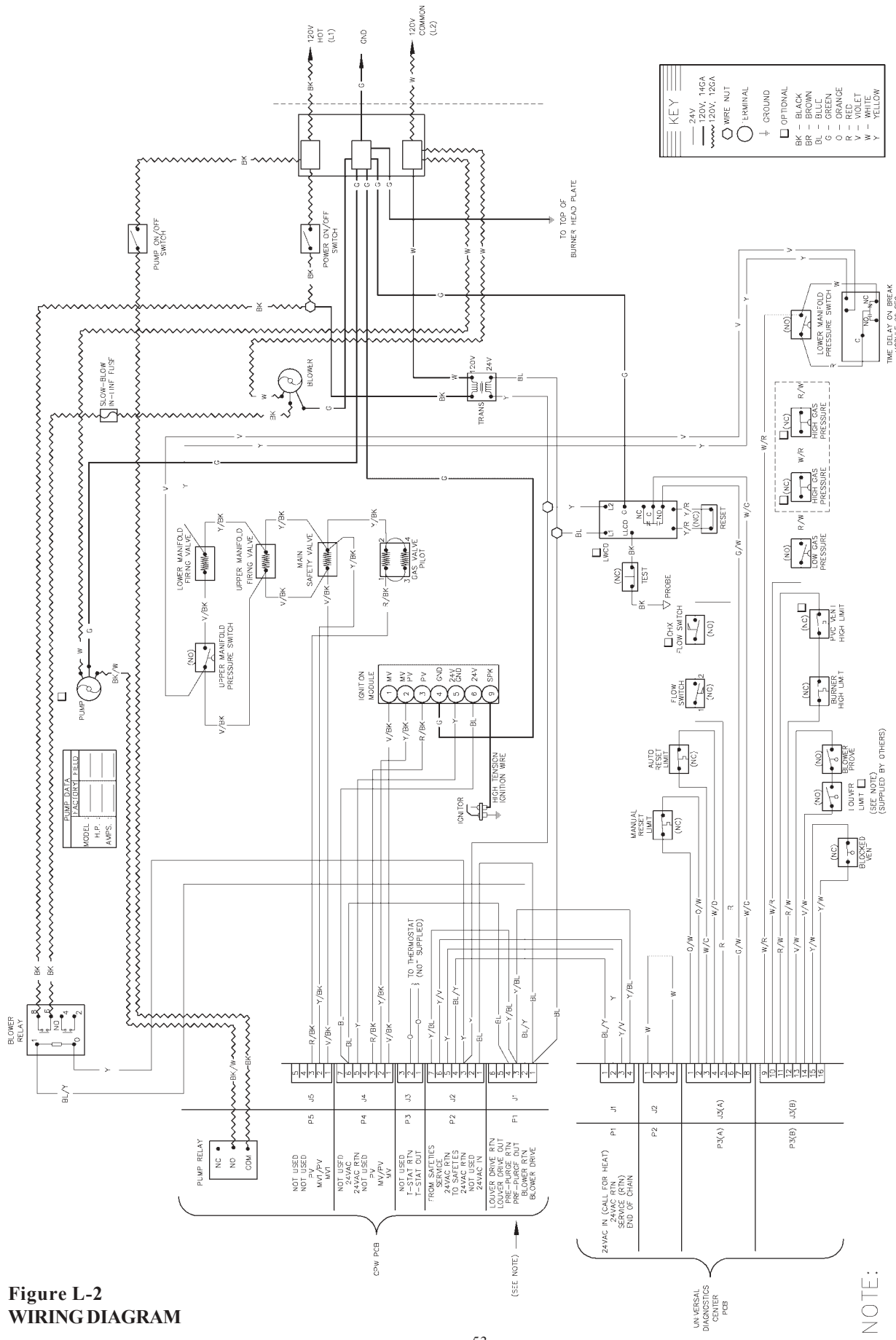

- NOTE:**
- ✓CHECK CONTROLS PROVIDED (WIRED AS SHOWN).
 - REPLACE WIRING WITH 105°C WIRE ONLY.
 - BOILER INPUT: 750,000 TO 1,500,000 B1UH
 - WHEN A LOUVER IS USED, A LOUVER LIMIT SWITCH MUST BE PLACED IN SERIES WITH THE BLOWER SWITCH. CONTACT FACTORY FOR DETAILS.

IGNITION CONTROL MODULE

The intermittent ignition device conserves energy by automatically extinguishing the pilot when the desired temperature is reached. When additional heat is needed, the combustion air blower starts to purge all air from the combustion chamber for about 45 seconds. On proof of air flow, the air proving switch closes and the pilot reignites electrically, eliminating the fuel costs of maintaining a constant pilot. To assure safe operation, the gas valve cannot open until the pilot relights and is verified. The 100% pilot safety is an electronic device which closes the main gas valve within 8/10 of a second whenever the pilot flame is interrupted. Pilot flame is automatically lit when the device is powered and pre-purged. Unit performs its own safety check and opens the main valve only after the pilot is proven to be lit.

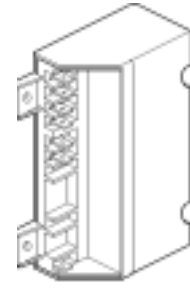

IGNITION MODULE

HIGH LIMIT - MANUAL RESET

This appliance is equipped with a manual reset, high limit, **safety** device. Push the reset button and adjust the setting to 40°F above the desired operating temperature.

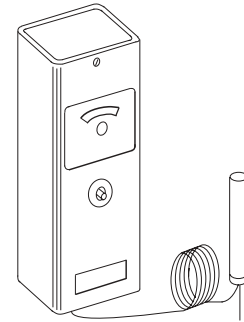

MANUAL RESET HIGH LIMIT

FLOW SWITCH

Dual-purpose control shuts off boiler in case of pump failure or low water condition. Mounted and wired in series with the main gas valve. Check with Manufacturer for proper paddle size. Utilize correct paddle size for proper operation.

NOTICE: *Flow switch will not operate if flow is less than 20 GPM.*

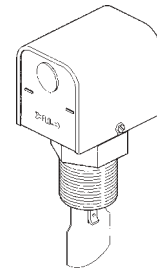

FLOW SWITCH

HIGH LIMIT - AUTO RESET

This appliance is equipped with an automatic, high limit, **safety** device. Set the auto high limit to 30°F above the desired operating temperature.

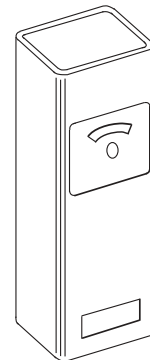

AUTO RESET HIGH LIMIT

LOW WATER CUT OFF (OPTIONAL)

The low water cut off automatically shuts down the burner whenever water level drops below the level of the sensing probe. A 3 second time delay prevents premature lockout due to temporary conditions such as power fluctuations or air pockets.

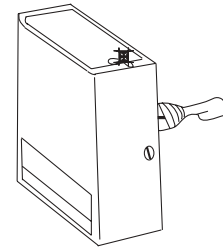

LOW WATER CUT OFF

HIGH AND LOW GAS PRESSURE SWITCHES - MANUAL RESET

The low gas pressure switch mounts upstream of the gas pressure regulator to ensure that sufficient gas pressure is present for proper regulator performance. The low gas pressure switch automatically shuts down the boiler if gas supply drops below the factory setting of 6" W.C. for Natural gas, and 10" W.C. for propane gas.

The high gas pressure switch (optional) mounts down-stream of the gas pressure regulator. If the gas pressure regulator fails, the high gas pressure switch automatically shuts down the burner.

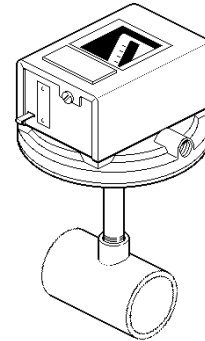

GAS PRESSURE SWITCH

SECTION M: GENERAL SAFETY PRECAUTIONS

To meet commercial water use needs, an external operating control for this hot water boiler is adjustable up to 210°F. However, water temperatures over 125°F can cause instant severe burns or death from scalds. The preferred starting point for setting the control for supplying general purpose hot water is 125°F.

Safety and energy conservation are factors to be considered when setting the water temperature on the thermostat. The most energy efficient operation will result when the temperature setting is the lowest that satisfies the needs consistent with the application.

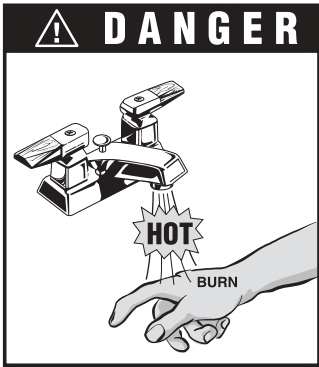

Water temperature over 125°F can cause severe burns instantly or death from scalds.

Children, disabled and elderly are at highest risk of being scalded.

See instruction manual before setting temperature at water heater.

Feel water before bathing or showering.

Temperature limiting valves are available, see note below.

Maximum water temperatures occur just after the boiler’s burner has shut off. To determine the water temperature being delivered, turn on a hot water faucet and place a thermometer in the hot water stream.

The following chart details the relationship of water temperature and time with regard to scald injury and may be used as a guide in determining the safest water temperature for your applications.

Temperature	Time to Produce Serious Burn	Temperature	Time to Produce Serious Burn
120°F.	More than 5 minutes	140°F.	Less than 5 seconds
125°F.	1-1/2 to 2 minutes	145°F.	Less than 3 seconds
130°F.	About 30 seconds	150°F.	About 1-1/2 seconds
135°F.	About 10 seconds	155°F.	About 1 second

Table courtesy of The Shriners Burn Institute

TIME/TEMPERATURE RELATIONSHIPS IN SCALDS

The temperature of the water in the hot water boiler can be regulated by setting the temperature dial on front of the thermostat. To comply with safety regulations the thermostat was set at its lowest setting before the hot water boiler was shipped from the factory. The illustration below shows the thermostat and how to adjust the water temperature.

To adjust the water temperature, insert a small straight screwdriver into slotted screw in hole in front of thermostat and turn wheel to desired setting.

CAUTION!! - Hotter water Increases the risk of SCALDING!

There is a Hot Water SCALD Potential if the tank thermostat is set too high.

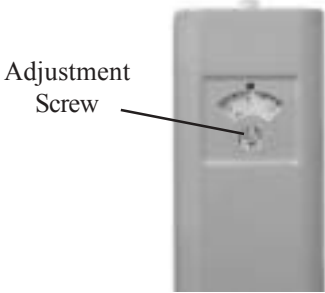

NOTE: When this hot water boiler is supplying general purpose hot water requirements for use by individuals, a thermostatically controlled mixing valve for reducing point of use water temperature is recommended to reduce the risk of scald injury. Contact a licensed plumber or the local plumbing authority for further information.

SECTION N: PRE-START-UP

FILL THE SYSTEM:

1. Close manual and automatic air vents and drain cock.
2. Fill to correct system pressure. Correct pressure will vary with each application.
3. Open automatic air vent two turns.
4. Slowly feed water to boiler.
5. Starting on the lowest floor, open air vents one at a time until water squirts out. Close vent.
6. Repeat with remaining vents.
7. Close manual water feed valve when correct boiler pressure is reached.

INSPECT VENTING SYSTEM:

1. Check all vent pipe connections and flue pipe material.
2. Ensure vent terminations are installed per code and are clear of all debris or blockage.

FOR YOUR SAFETY READ BEFORE LIGHTING

WARNING: *If you do not follow these instructions exactly, a fire or explosion may result causing property damage, personal injury or loss of life.*

1. This appliance does have an intermittent pilot. It is equipped with an ignition device which automatically lights the pilot. Do Not try to light the pilot or burner by hand.
2. BEFORE OPERATING, smell all around the appliance area for gas. Be sure to smell next to the floor because some gas is heavier than air and will settle on the floor.
3. WHAT TO DO IF YOU SMELL GAS
 - Do not try to light any appliance.
 - Do not touch any electrical switch; do not use any telephone in your building.
 - Immediately call your gas supplier from a neighbor's telephone. Follow the gas supplier's instructions.
 - If you cannot reach your gas supplier, call the fire department.
4. Use only your hand to push in or turn the gas control knob. Never use tools. If the knob will not turn by hand, do not try to repair it, call a qualified service technician. Forced or attempted repair may result in a fire or explosion.
5. Do not use this appliance if any part has been under water, immediately call a qualified service technician to inspect the appliance and to replace any part of the control system and any gas control which has been under water.

PRE-START-UP CHECK

1. Verify boiler is filled with water.
2. Check system piping for leaks. If found, repair immediately.
3. Vent air from system. Repeat steps 4 and 5 under "Fill the System." Air in system can interfere with water circulation and cause improper heat distribution.

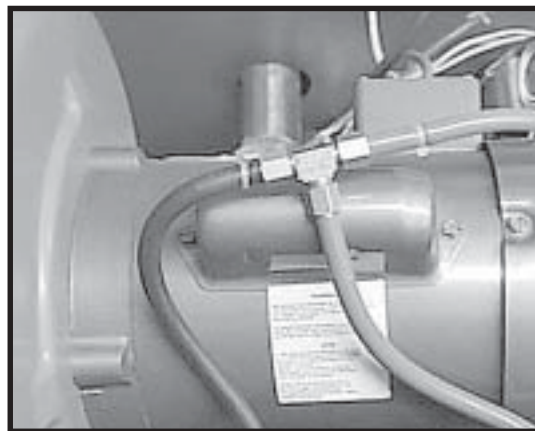
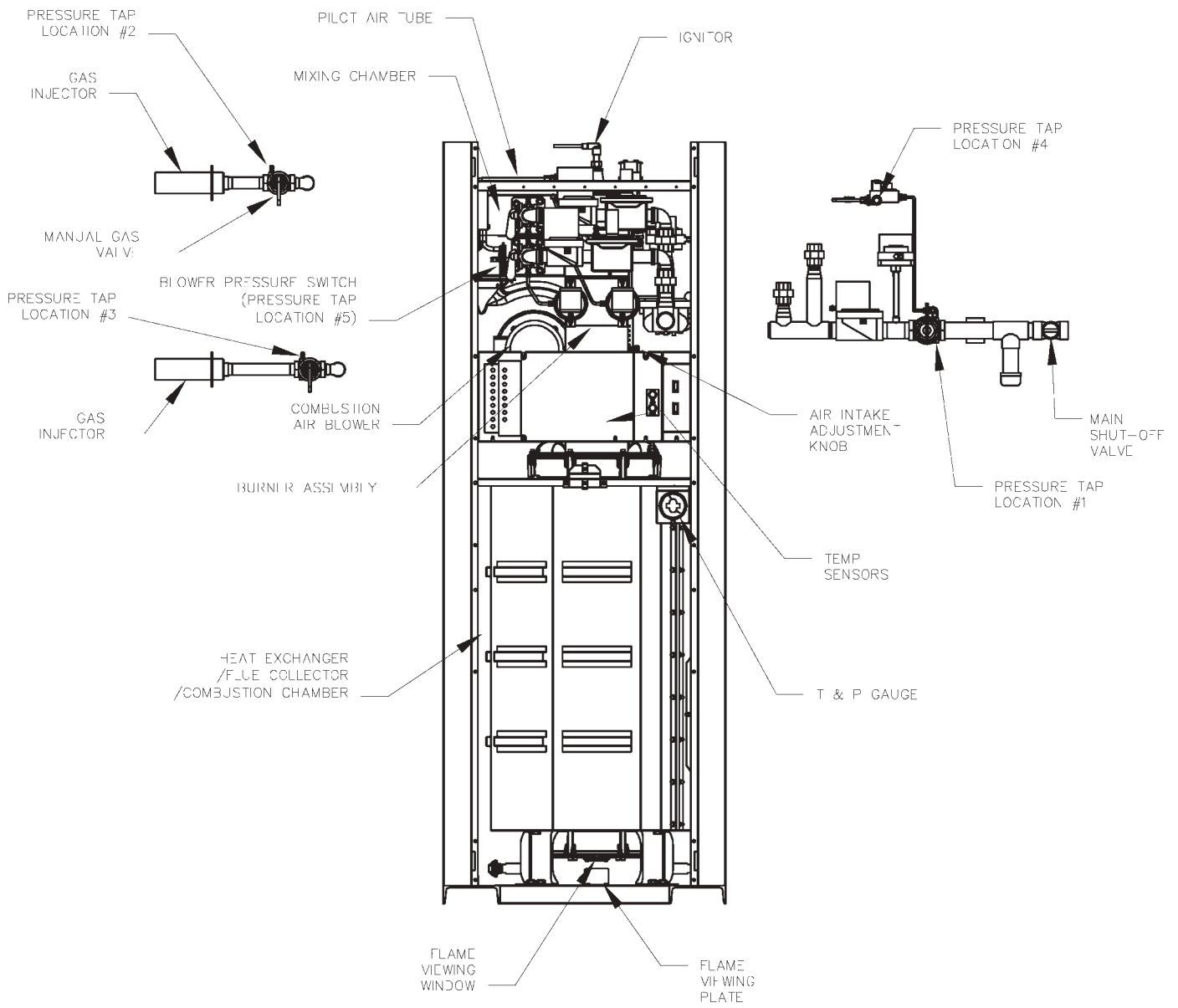

Blower "T" fitting detail.

Figure O-1
COMPONENT AND PRESSURE TAP LOCATIONS

SECTION O: ADB INITIAL START-UP

CAUTION: Verify that the vent system and combustion air supply have been approved.

1.0 TOOLS NEEDED

- One 8-0-8, 16" scale manometer (or larger)
- Four 4-0-4, 8" scale manometers (or larger)
- "T" fitting
- 7/16" and 1/2" open end wrenches
- Small and large flat-head screwdrivers
- Volt meter
- Amp probe
- Elec. Dual reading thermometer with strap on sensors
- 3/16" Allen wrench
- Combustion analyzer

2.0 PREPARATION FOR START-UP

WARNING: DO NOT TURN ON GAS AT THIS TIME

2.1 Check Power Supply

With voltmeter at incoming power check voltage between:

Hot - Common	(»120 VAC)
Hot - Ground	(»120 VAC)
Common - Ground	(<1 VAC)

If Common - Ground is > 1 VAC - STOP: Contact electrician to correct ground failure.

WARNING: Failure to do this may burn out 120V-24V transformer, or may cause other safety control damage or failure.

2.2 Attach Manometers to Measure Pressures (See Figure: O-1)

- Attach 16" scale manometer to the first gas shut-off valve pressure tapping, Location (1)
- Attach one 8" scale manometer to each manual gas valve pressure tapping, Locations (2) and (3).
- Attach one 8" scale manometer to the outlet side of pilot gas valve pressure tapping, Location (4).
- Attach one 8" manometer to "T" fitting, air pressure switch, and aluminum tubing, Location (5).

Turn Off The 1 ½ " Manual Gas Valve;
Turn Off Pilot Gas Valve;
Reset Low Gas Pressure Cut-off Switch;

2.3 Bleed Air from Gas Line

CAUTION: Make sure there is no ignition source in the boiler room

- With power off, slightly open union outside the cabinet to bleed air.
- Close union when you smell gas.
- Wait minimum 5 minutes to clear the gas out of the boiler room before continuing.

2.4 Check the Gas Supply Pressure, Location (1)

- Leave pilot gas valve and first manual gas valve closed;
- Slowly turn on main gas shut-off valve (outside the unit);
- Read the gas supply pressure from the manometer (Location 1);
- If pressure is > 14" W.C., Turn off the valve;
- Check if the service regulator is installed and/or adjust the service regulator.

3.0 START-UP

NOTICE: Reference the start-up pressures settings located on the side of the control box.

3.1 Blower Adjustment

1. Main gas shut-off valve is still closed;
2. Turn power on;
3. Check blower manometer reading, Location (5). Compare your reading to the “Pre-Fire” values shown in tables O-2 and O-3. If not, adjust the air shutter on the blower to attain the correct value;
4. Turn power off.

3.2 Pilot Adjustment

1. Turn on the gas shut-off valve, the main gas manual valve, and the pilot manual valve;
2. Turn off the manual gas valves at Locations (2) and (3);
3. Turn power on, after 40-45 seconds, ignition control will energize and send spark to ignition, observe through view port for spark;
4. If you do not see spark, turn off power, check ignition wire and proper grounding and wiring. Turn power back on. Repeat Step 3. If there is still no spark after several attempts the igniter may be misaligned;
5. Check to see if igniter is grounded out by pulling the spark wire and doing a continuity check between the igniter and burner. If the igniter is grounded out, it must be realigned. Remove the burner. Loosen the igniter nut, locate the igniter in the center of the burner head and tighten igniter nut. Confirm it is centered and reinstall burner head;
6. If you have spark, turn off unit;
7. Turn on power. Unit will pre-purge 40-45 seconds and to ignition trial. You will hear a click from pilot gas valve (you will not hear the sparking);
8. The pilot may not light at first trial; leave the unit running until you have pilot. If you still do not see pilot over 90 seconds; turn off the unit; repeat steps 6-8;
9. Check pilot manifold pressure, Location (4). Compare the reading to the value listed in the tables;
10. Check pilot flame; 8 distinct circular blue flames around the center of the pilot;
11. Replace the cap for pilot manifold adjustment screw; do not over-tighten.

TABLE O-2: Pressure Settings and Emission Guidelines (True Readings) for NAT. GAS

NATURAL GAS	Blower		Main Gas		Pilot Gas	CO ₂ % ± 0.3	O ₂ % ± 0.3	CO ppm Max	No _x ppm Max
	Pre-Fire	Firing	Top	Bottom					
ADB 751	3.5	3.7	2.4	2.4	3.5	8.3	6.1	150	20
ADB 751+CHX	3.6	3.8	2.7	2.7	3.6	8.3	6.1	150	20
ADB 1001	3.3	3.5	2.6	2.7	3.9	8.3	6.1	150	20
ADB1001+CHX	3.4	3.6	2.9	2.9	3.9	8.3	6.1	150	20
ADB 1501	3.4	3.7	2.6	2.1	3.5	9.2	4.5	150	20
ADB 1501+CHX	3.7	4.0	2.9	2.2	3.9	9.2	4.5	150	20

Note: For different gas control options, call factory for proper pressure settings (ie; IRI, etc)

TABLE O-3: Pressure Settings and Emission Guidelines (True Readings) for LP GAS

PROPANE GAS	Blower Pre-Fire	Blower Firing	Main Gas		Pilot Gas	CO ₂ % ± 0.3	O ₂ % ± 0.3	CO ppm Max
			Top	Bottom				
ADB 751	3.5	3.7	3.1	3.1	9.5	9.9	5.9	150
ADB 751+CHX	3.6	3.8	3.5	3.2	9.7	9.9	5.9	150
ADB 1001	3.4	3.6	3.7	3.7	9.5	9.7	6.2	150
ADB1001+CHX	3.6	3.8	4.1	4.2	9.5	9.7	6.2	150
ADB 1501	N/A	N/A	N/A	N/A	N/A	N/A	N/A	N/A
ADB 1501+CHX	N/A	N/A	N/A	N/A	N/A	N/A	N/A	N/A

Note: For different gas control options, call the factory for proper pressure settings (i.e. IRI, etc)

NOTICE: Emissions will vary with different applications (hydronic, water heater, or pool), venting (including direct vent), ambient conditions (T, P, and humidity), and the condition of the boiler.

NOTICE: For high altitude (above 5000 ft), call the factory for proper pressure settings.

3.3 Main Burner Adjustment

1. Turn on the unit; about 45 seconds later, the pilot should light. If the pilot fails to light, repeat step 3.2 for pilot adjustment;
2. Turn the top manual valve on, Location (2). The inner burner will fire;
3. Make sure that the supply gas manometer reads between 7 – 14” W.C. (dynamic pressure);
4. Check manifold pressure, Location (2); this should read to within ± 0.1” W.C. of the values shown in tables O-2 and O-3;
5. If adjustment is required, remove screw cap off the top gas pressure regulator, and adjust regulator;
6. Slowly turn the bottom manual valve on, Location (3). The outer burner will fire;
7. Make sure that the supply gas manometer reads between 7 – 14” W.C. (dynamic pressure);
8. Check manifold pressure, Location (3); this should read to within ± 0.1” W.C. of the values shown in tables O-2 and O-3;
9. If adjustment is required, remove screw cap off the bottom gas pressure regulator, and adjust regulator;
10. The blower pressure should increase about 3/10” (0.3”) W.C. equaling the “Firing” value in tables O-2 and O-3;
11. Lock the blower shutter by tightening the shutter nut while holding the black knob fixed;
12. Allow minimum 5 minutes of run time; then attach flue analyzer, check emission and compare the CO₂ reading to that of table O-2 & O-3;
13. If CO₂ is high, reduce bottom manifold gas pressure;
14. If CO₂ is low, increase the bottom manifold gas pressure;
15. All pressure readings especially manifold pressures should be within ±0.1” of listed values;
16. Replace the screw caps back on the gas regulators.

Your ADB is tuned in!

3.4 Safety Inspection

- Check thermostat and high limit settings.
- Attach thermometers to IN/OUT piping and take temperature measurement, see Table D-1 and F-1 for correct flow balance.
- During the following safety checks leave manometers, and analyzer hooked up, check and record.
- If other gas fired equipment in the room and on same gas main, check gas pressures on ADB with them running.

Remember supply gas should always be between 7” and 14” W.C.

- Check thermostat control for ON/OFF operation;
- Check safety Hi Limits for ON/OFF operation;
- While in operation inspect flow switch;
- Check the low gas pressure switch, it is factory set at 6” W.C. for natural gas;
- High gas pressure switch (optional) at 1” W.C. above manifold pressure;
- Insert ignition control lockout test as safety check.

3.5 Follow-up

- Safety checks must be recorded as performed;
- Turn unit on;
- After main burner ignition. Check Manometers for proper readings;
- Verify that the blower shutter is locked;
- Cycle unit several times and recheck readings;
- Re-analyze with unit running record or print results;
- Turn unit off, remove all Manometers and replace blower switch hose, replace all gas pressure caps and plugs;
- Check for gas leak one more time;
- Check around unit for debris and remove combustible and flammable products, i.e. paper, gasoline etc.

SECTION P: POST START-UP CHECK

Check off steps as completed:

1. Boiler and heat distribution units or storage tank filled with water?
2. Automatic air vent, if used, open two full turns during venting procedure?
3. Air purged from system?
4. Air purged from gas piping? Piping checked for leaks?
5. Followed start-up procedure for proper start-up?
6. Is burner flame visible?
7. Test safety controls: If boiler is equipped with a low water cutoff or additional safety controls, test for operation as outlined by manufacturer. Burner should be operating and should go off when controls are tested. When safety devices are restored, burners should reignite after pre-purge time delay.
8. Test limit control: While burner is operating, move indicator on high limit control below actual boiler water temperature. Burner should go off while blower circulator continues to operate. Raise setting on limit control above boiler water temperature and burner should reignite after pre-purge time delay.
9. Test ignition system safety device:
 - Turn power off.
 - Close the pilot manual valve.
 - Turn power on; after about 45 seconds of pre-purge, the pilot comes on. The pilot (and therefore the burner) should fail to light. The standard lockout time is 90 seconds; then the pilot light goes off and the boiler goes into post-purge. (If the lockout module is attached to boiler, a lockout light comes on.)
 - Turn the power off; open the pilot manual valve; (reset the lockout module if applicable).
 - Wait 30 seconds, then turn power on. The burner should ignite after pre-purge time delay.
10. To restart system, follow lighting instructions in Section O.
11. High limit control set to design temperature requirements of system?
For multiple zones: flow adjusted as required in each zone?
12. Boiler cycled with thermostat? Raise to highest setting and verify boiler goes through normal start-up cycle.
Reduce to lowest setting and verify boiler goes off.
13. Observed several operating cycles for proper operation?
14. Set room thermostat or tankstat to desired temperature?
15. Reviewed all instructions shipped with this boiler with owner or maintenance personnel, returned to envelope and given to owner or placed in pocket inside front panel on boiler?

SECTION Q: OPERATION

OPERATING INSTRUCTIONS

Lighting Instructions

1. **STOP!** Read the safety information first.
2. Set the thermostat to the lowest setting.
3. Turn off all electric power to the appliance.
4. This appliance is equipped with an ignition device which automatically lights the burner. Do Not try to light the burner by hand.
5. Remove upper front panel.
6. Turn on main manual gas valve and pilot manual gas valve.
7. Wait five (5) minutes to clear out any gas. Then smell for gas, especially near the floor. If you then smell gas. **STOP!** Follow the steps in the safety information.
If you do not smell gas, go to next step.
8. Turn on all electric power to the appliance.
9. Set thermostat to desired setting. The appliance will operate. The pilot burner will light after the pre-purge time delay (45 seconds). Then the pilot will light the main burner.
10. If the appliance will not operate, follow the instruction "To Turn Off Gas To Appliance", and contact a qualified service technician.
11. Replace upper front panel.

TO TURN OFF GAS TO APPLIANCE

1. Set the thermostat to lowest setting.
2. Turn off all electric power to the appliance if service is to be performed.
3. Remove upper front panel.
4. Turn off main manual gas valve and manual pilot gas valve.
5. Replace access panel.

If boiler fails to start, check for:

- Loose connections, blown fuse or service switch off?
- High temperature limit switch set below boiler water temperature?
- Thermostat set below room temperature?
- Gas not turned on at meter or boiler?
- Incoming dynamic gas pressure less than 6" W.C. for Natural gas, 10" W.C. for Propane?

SECTION R: MAINTENANCE

SUGGESTED MINIMUM MAINTENANCE SCHEDULE:

Regular service by a qualified service agency and maintenance must be performed to assure maximum boiler operating efficiency.

Maintenance as outlined below may be performed by the owner.

Yearly (Beginning of each heating season):

1. Annual service call by qualified service agency.
2. Visually check top of vent for soot. Call service person to clean. Some sediment at bottom of vent is normal.
3. Visually inspect venting system for proper function, deterioration or leakage.
4. Check that boiler area is free from combustible materials, gasoline, and other flammable vapors and liquids.
5. Check for and remove any obstruction to the flow of combustion or ventilation air to boiler.
6. Follow pre-start-up check in Section N.
7. Visually inspect burner flame. Should see light blue flame, with some orange at flame edge.
8. Check operation of safety devices. Refer to manufacturer's instructions.
9. Follow oil-lubricating instructions on circulator. Over-oiling will damage circulator. Water-lubricated circulators do not need oiling.
10. Visually inspect condensate drain piping for proper operation or deterioration (if appropriate). Check for plugged condensate trap. Use cleanout plug to clear trap.
11. To avoid potential of severe burn, DO NOT REST HANDS ON OR GRASP PIPES. Use a light touch - return piping will heat up quickly.
12. If mixing valve does not seem to be working, the spring and thermostat may need to be replaced. Call a qualified service technician.
13. Check for piping leaks around circulators, mixing valves, relief valves and other fittings. Repair, if found. DO NOT use petroleum based stop leak.

Daily:

1. Check that boiler area is free from combustible materials, gasoline, and other flammable vapors and liquids.
2. Check for and remove any obstruction to the flow of combustion or ventilation air to boiler.

Monthly:

1. Check for piping leaks around circulators, mixing valves, relief valves, and other fittings. If found, repair at once. DO NOT use petroleum-based stop leak compounds.
2. Visually inspect burner flame.
3. Visually inspect venting system for proper function, deterioration or leakage.
4. Check air vents for leakage.
5. Check the hose fitting/orifice on the blower. Make certain that orifice is not blocked by grease, dirt or any other debris. If necessary, use a thin wire to clean up the orifice.

Periodically:

1. Check relief valve. Refer to manufacturer's instructions on valve.
2. Test low water cutoff, if used. Refer to manufacturer's instructions.
3. Visually inspect condensate drain hose for proper operation or deterioration (if appropriate). Check for plugged condensate trap. Use cleanout plug to clear trap.
4. Clean screen in vent termination and air intake.

CLEANING BOILER HEATING SURFACES:

The following service procedures must be performed ONLY by a qualified service agency. Boiler owner should not attempt these procedures.

1. If you find soot in top of vent elbow (some sediment in bottom of vent is normal) - remove vent attachment to the ADB and clean flue exhaust baffle inside the boiler. Also check burner, replace if damaged.
2. If you find rust deposits in vent elbow - check for high water flowrate or low inlet water temperatures. Clean boiler as above.

SECTION S: CONNECTING CONDENSING HEAT EXCHANGER (CHX)

Refer to Figure S-1 for the following steps:

NOTICE: Connect the vent before connecting the water piping.
Install unions on water inlet and outlet of CHX for ease of maintenance. The CHX require cleaning as often as once the year.

1. Remove the shroud.
2. Remove the top cover.
3. Secure the 15° elbows (supplied) as shown one on each side of the CHX, using the stainless steel screws (supplied).
4. Seal the connection with high temperature RTV (supplied).
5. Replace the top cover.
6. Level the CHX with the ADB by adjusting the leveling screws at the base.
7. Place a line of RTV on the crimped end of the flue outlet from the ADB and slide the CHX to join the ADB flue outlet to the CHX flue inlet.
8. Connect the CHX water as specified in the piping diagram. Check for water leak.
9. Secure the flue connection from step 7 above with the stainless steel screws (supplied).
10. Connect the flue vent (Category IV venting, UL 17-38 Certified Venting Material) to the 15° elbow of the CHX flue outlet.
11. Connect the PVC pipe (not supplied) for condensate water disposal (check with local authority regarding condensate disposal).
12. Replace the shroud.
13. Allow the silicone (RTV) to cure over-night.

VENTSWITCHADJUSTMENT:

In order to insure proper operation of the ADB boiler with a CHX attached to it, **the vent switch must be adjusted** to proper setting. The vent switch is located on the J-box, just outside the ignition module. Use the following steps:

- Turn power off; disconnect the electrical wiring and the rubber hose.
- Remove the switch (it has a black plastic orifice at the hose connection).
- On the backside, remove the (purple) seal from atop the adjusting screw.
- Turn the plastic hex screw 1½ turn clockwise.
- Seal with silicone.
- Reinstall in reverse order.

CHX Rate of Flow and Pressure Drop

751	GPM	32	37	42	50	63	77	110
	ΔP	0.6	1.2	1.3	1.4	1.8	2.5	5.1
1001	GPM	42	51	56	66	84	97	110
	ΔP	1.1	1.6	1.8	2.8	4.4	5.1	6
1501	GPM	xx	52	63	74	84	98	126
	ΔP	xx	1.8	2.7	3.6	4.5	6	9.4

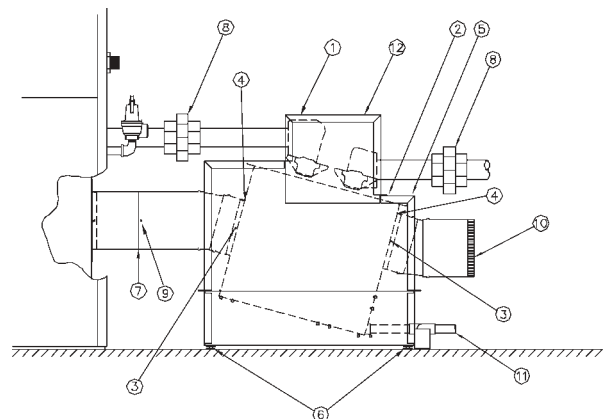

Figure S-1
Connecting Add-On Condensing Heat Exchanger to ADB

APPENDIX A

INSIDE COMBUSTION AIR CONTAMINATION:

All boilers experience some condensation during start-up.

The condensate from flue gas is slightly acidic. In most cases the pH level is not harmful to vents or drains. When combustion air is contaminated by vapors from products in areas listed below, the acidic levels in the condensate increase. Higher acidic levels attack many materials, including stainless steel commonly used in high efficiency systems.

The boiler can use special corrosion-resistant nonmetallic vent material. You may, however, choose to use outside combustion air for one or more of these reasons:

- installation is in an area containing contaminants listed below which will induce acidic condensation.
- you want to reduce infiltration into your building through openings around windows and doors.
- you are using AL29-4C stainless steel vent pipe, which is more corrosion-resistant than standard metallic vent pipe. In extremely contaminated area, this may also experience deterioration.

Products causing contaminated combustion air:

- spray cans containing chloro/fluorocarbons
- permanent wave solutions
- chlorinated waxes/cleaners
- chlorine-based swimming pool chemicals
- calcium chloride used for thawing
- sodium chloride used for water softening
- refrigerant leaks
- paint or varnish removers
- hydrochloric acid/muriatic acid
- cements and glues
- anti-static fabric softeners used in clothes dryers
- chloride-type bleaches, detergents, and cleaning solvents found in household laundry rooms
- adhesives used to fasten building products
- ... and other similar products.

Areas causing contaminated combustion air:

- dry cleaning/laundry areas and establishments
- metal fabrication plants
- beauty shops
- refrigeration repair shops
- photo processing plants
- auto body shops
- plastic manufacturing plants
- furniture refinishing areas and establishments
- new building construction
- remodeling areas.

Check for areas and products as listed above before installing boiler. If found:

- remove products permanently, OR
- provide outdoor combustion air.

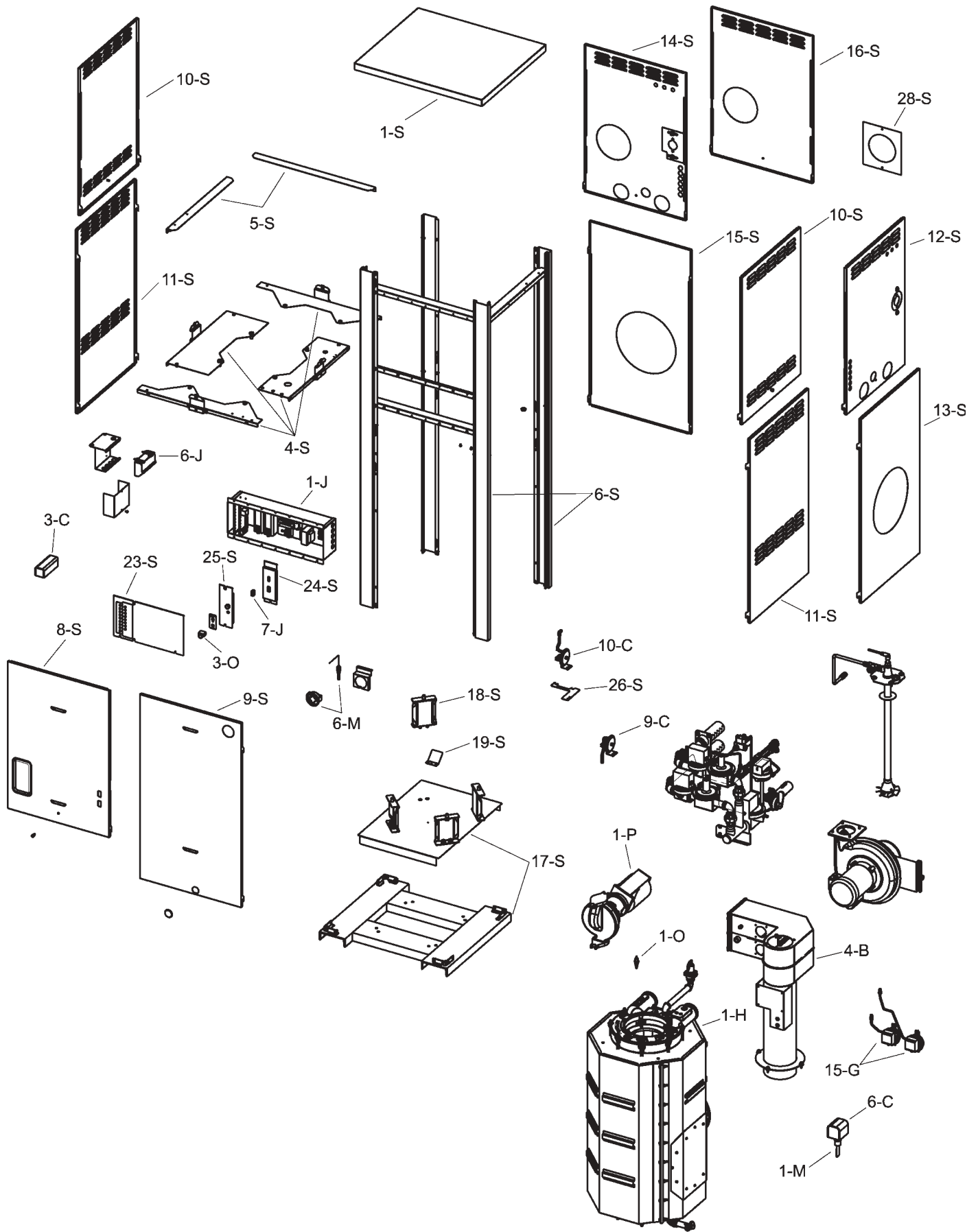

HEAT EXCHANGER DETAIL

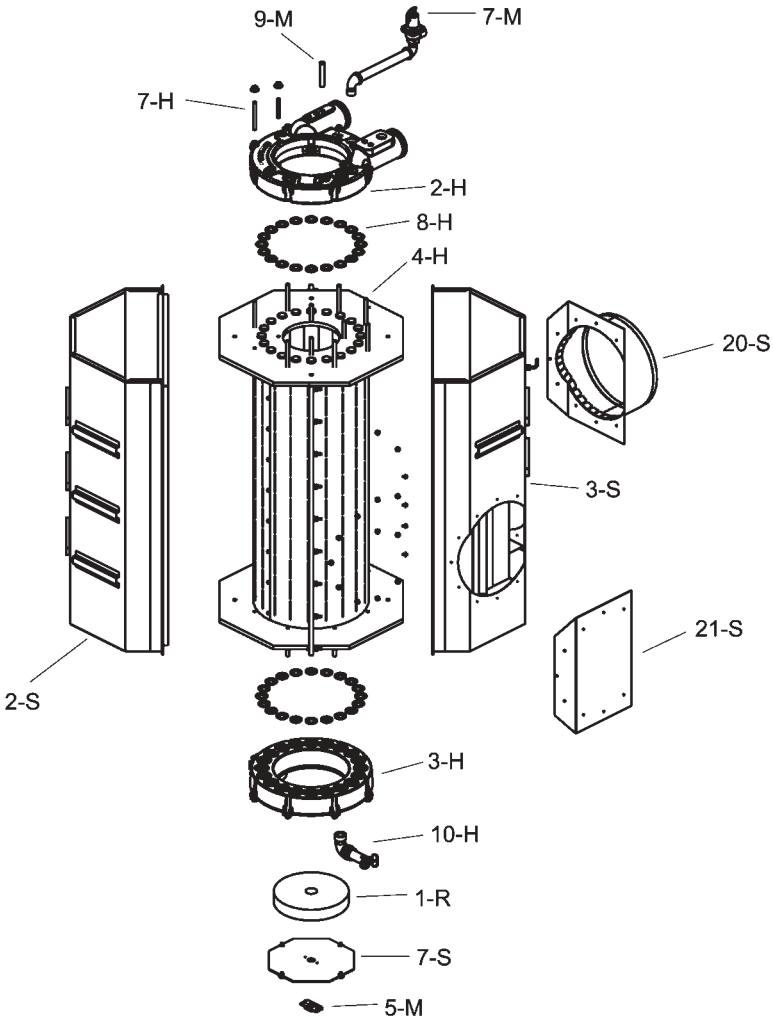

J-BOX DETAIL

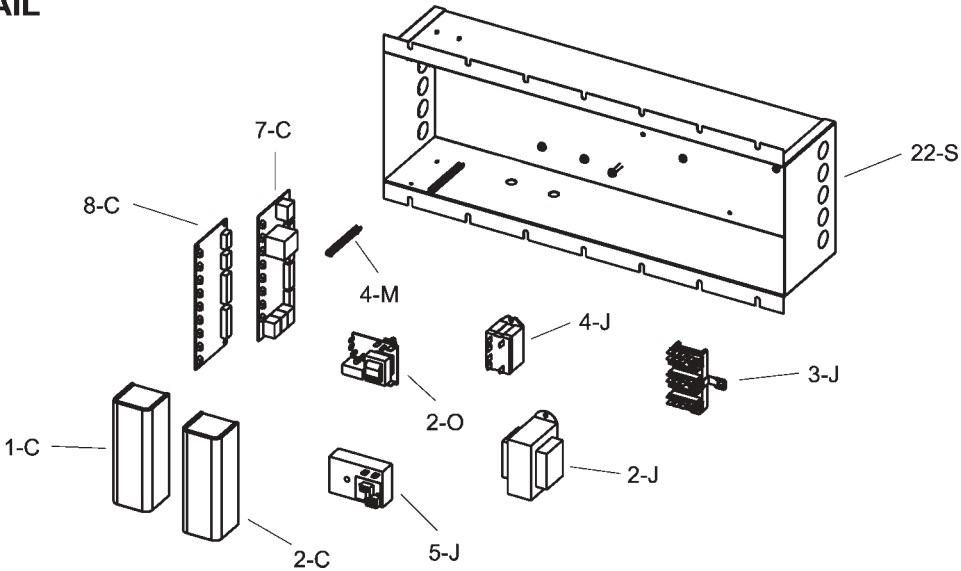

GAS TRAIN DETAIL

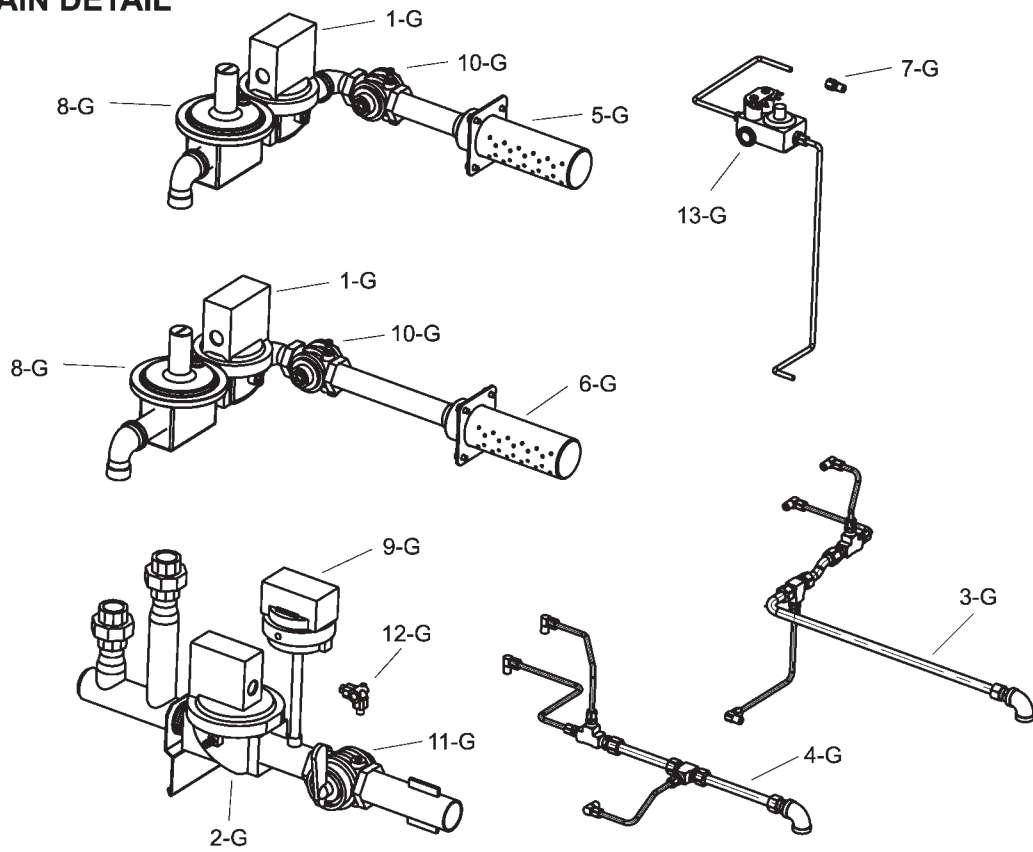

BURNER HEAD DETAIL

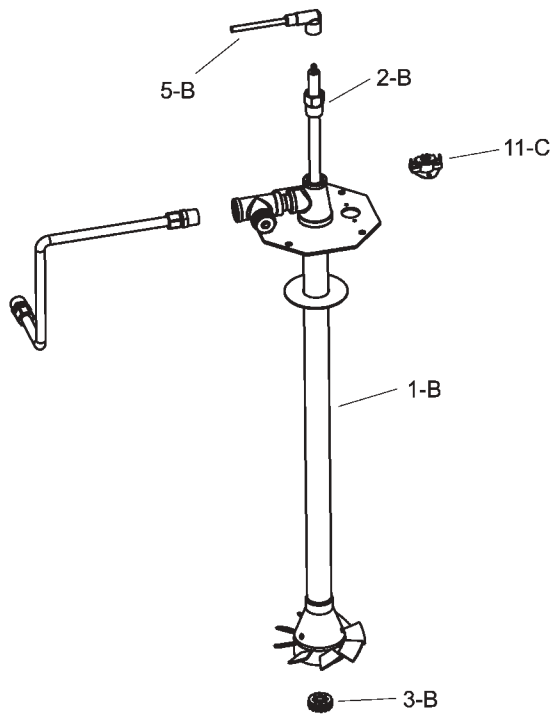

BLOWER DETAIL

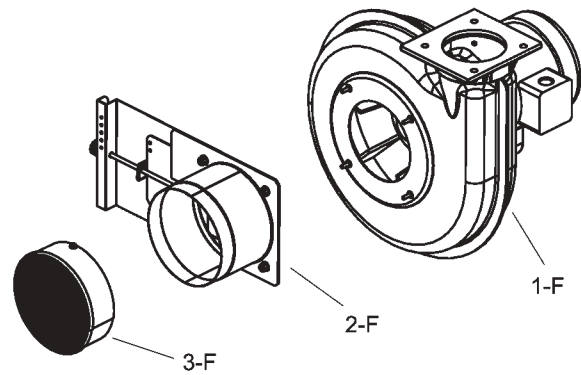

CALL OUT	DESCRIPTION	751	1001	1501
B	BURNER ASSEMBLY			
1-B	Burner / Pilot Assembly IID	008787F	008787F	007108F
	Burner / Pilot Assembly C-2	008788F	008788F	007113F
2-B	Ignitor-Spark Rod	007922F	007922F	007922F
3-B	Pilot Burner	007923F	007923F	007923F
4-B	Plenum Assembly Complete	008789F	008790F	007134F
5-B	High Tension Wire	009058F	009058F	009058F
C	CONTROLS			
1-C	Auto Reset High Limit 240	007141F	007141F	007141F
	Auto Reset High Limit 200	006445F	006445F	006445F
2-C	Manual Reset High Limit 240	007144F	007144F	007144F
	Manual Reset High Limit 200	008081F	008081F	008081F
3-C	Remote Aquastat (Tankstat) B-2	007148F	007148F	007148F
	Remote Aquastat (Tankstat) 2-Stage B-3	007392F	007392F	007392F
	Remote Aquastat (Tankstat) 2-Stage B-9	006760F	006760F	006760F
4-C	Controller 4-Stage B-10 Digital	006759F	006759F	006759F
	Controller 2-Stage B-11 Digital	007395F	007395F	007395F
5-C	Controller On/Off B-20	006445F	006445F	006445F
6-C	Flow Switch	007142F	007142F	007142F
7-C	Printed Circuit Board Central Point Wiring	007146F	007146F	007146F
8-C	Printed Circuit Board U2	007147F	007147F	007147F
9-C	Switch Pressure Vent Normally Closed	007158F	007158F	007158F
10-C	Switch Pressure Air Normally Open	007163F	007163F	007163F
11-C	Thermostat Manual Reset	006035F	006035F	006035F
J	CONTROLS			
1-J	Control Box Complete	009094F	009094F	009094F
2-J	Transformer 120/24 100 VA	007373F	007373F	007373F
3-J	Terminal Block w / Ground Lug	008523F	008523F	008523F
4-J	Relay DPST 24 VAC	007925F	007925F	007925F
5-J	Time Delay Contactor	008667F	008667F	008667F
6-J	Ignition Control IID	007156F	007156F	007156F
7-J	Switch-Rocker SPST 16A	006872F	006872F	006872F
F	FAN			
1-F	Blower Combustion Air	008793F	008793F	008793F
2-F	Air Shutter Assembly	007926F	007926F	009095F
3-F	Cap Intake Vent	007162F	007162F	007162F
G	GAS TRAIN			
1-G	Auto On/Off Valve 1" (V-88)	004093F	004093F	004093F
2-G	Auto On/Off Valve 1-1/2" (V-88)	004095F	004095F	004095F
3-G	Bleed Line Assembly	007927F	007927F	007927F
4-G	Vent Line Assembly	007928F	007928F	007928F
5-G	Manifold-Gas Injector Nat Upper	008860F	007171F	007171F
	Manifold-Gas Injector Pro Upper	007176F	007176F	007176F
6-G	Manifold-Gas Injector Nat Lower	008794F	008795F	007929F
	Manifold-Gas Injector Pro Lower	008796F	008797F	007930F
7-G	Orifice Pilot Pro	007180F	007180F	007180F
	Orifice Pilot Nat	008826F	008826F	008826F
8-G	Regulator Gas 1" Nat Top	008869F	007932F	007932F
	Regulator Gas 1" Nat Bottom	007932F	007932F	007932F
	Regulator Gas 1" Pro	003570F	003570F	003570F
9-G	Switch Low Gas Pressure	007187F	007187F	007187F
10-G	Valve Gas Manual A 1"	007189F	007189F	007189F
11-G	Valve Gas Manual A 1-1/2"	007933F	007933F	007933F
12-G	Valve Gas Manual B	007195F	007195F	007195F
13-G	Valve Pilot Gas Nat	007196F	007196F	007196F
	Valve Pilot Gas Pro	007197F	007197F	007197F
14-G	Switch High Gas Pressure (optional) Not Shown	007188F	007188F	007188F
15-G	Gas Pressure Switch	008169F	008169F	008169F

CALL OUT	DESCRIPTION	751	1001	1501
H	HEAT EXCHANGER			
1-H	Heat Exchange Assy. Cupro-Nickle (Bronze Header) (Includes 18-S)	009096F	009097F	009098F
	Heat Exchange Assy. Copper (Bronze Header) (Includes 18-S)	009099F	009100F	009101F
2-H	Inlet/Outlet Header Bronze	009102F	009103F	009103F
3-H	Return Header Bronze	007204F	007204F	007204F
4-H	Tube Bundle Cupro-Nickle	N/A	N/A	N/A
	Tube Bundle Copper	N/A	N/A	N/A
5-H	Flue Baffle	N/A	N/A	N/A
6-H	Heat Shield Baffle (2 pcs)	N/A	N/A	N/A
7-H	Studbolt	009104F	009104F	009104F
8-H	Header Gasket (20 PCS)	007343F	007343F	007343F
9-H	Well-Bulb Sensor 1/2"x 3-5/16"	007211F	007211F	007211F
10-H	Drain Valve	006536F	006536F	006536F
M	MISCELLANEOUS COMPONENTS			
1-M	Flow Swich Paddle	004079F	004079F	004079F
2-M	In Line Fuse Holder (Not Shown)	007216F	007216F	007216F
3-M	Fuse 15 amp (Not Shown)	007936F	007936F	007936F
4-M	Guide PC Card	007143F	007143F	007143F
5-M	Window Combustion Chamber	006947F	006947F	006947F
6-M	T & P Guage 0-75 PSI Remote Mount	007344F	007344F	007344F
	T & P Guage 0-200 PSI Remote Mount	007345F	007345F	007345F
7-M	PRV 30 PSI	007218F	007219F	007748F
	PRV 45 PSI	007346F	007221F	007751F
	PRV 60 PSI	007222F	007222F	007753F
	PRV 75 PSI	007223F	007223F	007156F
	PRV 125 PSI	007224F	007224F	007224F
	PRV 150 PSI	007225F	007225F	007225F
8-M	RTV Sealant 2.8 oz	008924F	008924F	008924F
	RTV Sealant 10 oz	005755F	005755F	005755F
9-M	Touch up Paint (Green)	750125	750125	750125
	Touch up Paint (Dark Gray)	750126	750126	750126
O	OPTIONS			
1-O	Remote Sensor for Low Water Cut-Off	007228F	007228F	007228F
2-O	Low Water Cut Off PC Board	007157F	007157F	007157F
3-O	Test / Reset Switch	005641F	005641F	005641F
P	PUMPS			
1-P	Pump -Circulating - Bronze (Soft Water)	007226F	007227F	007351F
	Pump -Circulating - Bronze (Medium Water)	007347F	007348F	007937F
	Pump -Circulating - Bronze (Hard Water)	007350F	007351F	007937F
	Pump -Circulating - CI (Soft Water)	007232F	007233F	007357F
	Pump -Circulating- CI (Medium Water)	007353F	007354F	007938F
	Pump -Circulating- CI (Hard Water)	007356F	007357F	007938F
R	REFRACTORY			
1-R	Blanket Return Header Refractory	007241F	007241F	007241F

CALL OUT	DESCRIPTION	751	1001	1501
S	SHEETMETAL			
1-S	Jacket Top	009106F	009106F	009106F
2-S	Flue Collector Front (No opening)	007245F	007246F	007247F
3-S	Flue Collector Rear (opening)	008802F	008803F	007252F
4-S	Heat Transfer Supports	009107F	009107F	009107F
5-S	Upper Cabinet Supports	009108F	009108F	009108F
6-S	Vertical Cabinet Supports	009109F	009110F	009111F
7-S	Return Header Cover	007257F	007257F	007257F
8-S	Jacket Upper Front Panel	009112F	009112F	009112F
9-S	Jacket Lower Front Panel	009113F	009114F	009115F
10-S	Jacket Upper Side Panel	009116F	009116F	009116F
11-S	Jacket Lower Side Panel	009117F	009118F	009119F
12-S	Jacket Upper Right Side Panel Connection Optional	009120F	009120F	009120F
13-S	Jacket Lower Right Side Panel Connection Optional	009121F	009122F	009123F
14-S	Jacket Upper Rear Panel	009124F	009124F	009124F
15-S	Jacket Lower Rear Panel	009125F	009126F	009127F
16-S	Jacket Upper Rear Panel Connection Optional	009128F	009128F	009128F
17-S	Base Assembly	009129F	009129F	009129F
18-S	Leg Bracket (4 pcs per boiler)	007306F	007306F	007306F
19-S	Base Reflector Panel	007307F	007307F	007307F
20-S	Flue Exhaust Flange Assembly	008816F	008817F	007308F
21-S	Flue Exhaust Cover	008818F	008819F	007313F
22-S	Control Box Assy	009130F	009130F	009130F
23-S	Control Box Cover	009131F	009131F	009131F
24-S	Power/Pump Switch Mounting Panel	009132F	009132F	009132F
25-S	Control Box Inner Panel	009105F	009105F	009105F
26-S	Bracket Pressure Switch MTG	007161F	007161F	007161F
27-S	Valve Pilot Mounting Bracket (Not shown)	007198F	007198F	007198F
28-S	Intake Air Cover Panel	007315F	007315F	007315F

CHX - Condensing Heat Exchanger (Not Shown)

CALL OUT	DESCRIPTION	751	1001	1501
H	HEAT EXCHANGER			
1-H	Heat Exchange Assy. Bronze	007619F	007620F	007941F
2-H	Inlet Header Bronze	007621F	007622F	007622F
3-H	Outlet Header Bronze	007623F	007624F	007624F
4-H	Tube Bundle Cupro-Nickle	007626F	007627F	007942F
5-H	Studbolt	007628F	007628F	007628F
6-H	Header Gasket	800001B	800001B	800001B
7-H	Condensing Drain	007629F	007630F	007630F
S	SHEETMETAL			
1-S	Internal Chamber	007632F	008820F	007943F
2-S	Base Assy	007634F	007635F	007635F
3-S	Cover Panel Front	007637F	007638F	007944F
4-S	Cover Panel Rear	007640F	007641F	007945F
5-S	Cover Panel Left Side	007643F	007644F	007946F
6-S	Cover Panel Right Side	007646F	007647F	007947F
7-S	Header Top Cover	007648F	007648F	007648F

START-UP SETTINGS

TODAY'S DATE: _____

PRESSURE SETTINGS:

Blower (burner off)..... _____ "W.C.
Pilot..... _____ "W.C.
Main Burner (Top)..... _____ "W.C.
Main Burner (Bottom)..... _____ "W.C.
Blower (burner on) _____ "W.C.
Supply Gas (static) _____ "W.C.
Supply Gas (dynamic) _____ "W.C.
Power Supply..... _____ Volts

EMISSION: (Analyzer readings)

CO₂..... _____ %
CO..... _____ PPM
Excess Air..... _____ %
O₂..... _____ %
NO_x..... _____ PPM
Flue Temperature..... _____ °F
amb. Temperature..... _____ °F

**LIMITED PARTS WARRANTY
ADVANCED DESIGN BOILER™**

SCOPE:

Raypak, Inc. ("Raypak") warrants to the original owner that all parts of this boiler which are actually manufactured by Raypak will be free from failure under normal use and service for the specified warranty periods and subject to the conditions set forth in this Warranty. Labor charges and other costs for parts removal or reinstallation, shipping and transportation are not covered by this Warranty but are the owner's responsibility.

HEAT EXCHANGER WARRANTY:

- Ten (10) Years from date of boiler installation. This includes only cupro nickel with bronze or cast iron waterways.
- Twenty (20) Years from date of boiler installation against "Thermal Shock" (excluded, however, if caused by boiler operation at large changes exceeding 150°F between the water temperature at intake and boiler temperature, or operating at boiler temperatures exceeding 230°F).

BLUFF HEAD BODY BURNER WARRANTY:

- Ten (10) Years from date of boiler installation.

ANY OTHER PART MANUFACTURED BY RAYPAK:

One (1) Year warranty from date of boiler installation, or eighteen (18) months from date of factory shipment based on Raypak's records, whichever comes first.

SATISFACTORY PROOF OF INSTALLATION DATE, SUCH AS INSTALLER INVOICE, IS REQUIRED. THIS WARRANTY WILL BE VOID IF THE BOILER RATING PLATE IS ALTERED OR REMOVED.

ADDITIONAL WARRANTY EXCLUSIONS:

This warranty does not cover failures or malfunctions resulting from:

1. Failure to properly install, operate or maintain the boiler in accordance with our printed instructions provided;
2. Abuse, alteration, accident, fire, flood and the like;
3. Sediment or lime buildup, freezing, or other conditions causing inadequate water circulation;
4. High velocity flow exceeding boiler design rates;
5. Failure of connected systems devices, such as pump or controller;
6. Use of non-factory authorized accessories or other components in conjunction with the boiler system;
7. Failing to eliminate air from, or replenish water in, the connected water system;
8. Chemical contamination of combustion air or use of chemical additives to water.

PARTS REPLACEMENT:

Under this Warranty, Raypak will furnish a replacement for any failed part. The failed part must first be returned to Raypak if requested, with transportation charges prepaid, and all applicable warranty conditions found satisfied. The replacement part will be warranted for only the unexpired portion of the original warranty. Raypak makes no warranty whatsoever on parts not manufactured by it, but Raypak will apply any such warranty as may be provided to it by the parts manufacturer.

TO MAKE WARRANTY CLAIM:

Promptly notify the original installer, supplying the model and serial numbers of the unit, date of installation and description of the problem. The installer must then notify his Raypak distributor for instructions regarding the claim. If either is not available, contact Service Manager, Raypak, Inc., 2151 Eastman Avenue, Oxnard, CA 93030 or call (805) 278-5300. In all cases proper authorization must first be received from Raypak before replacement of any part.

EXCLUSIVE WARRANTY - LIMITATION OF LIABILITY:

This is the only warranty given by Raypak. No one is authorized to make any other warranties on Raypak's behalf. THIS WARRANTY IN LIEU OF ALL OTHER WARRANTIES, EXPRESS OR IMPLIED, INCLUDING BUT NOT LIMITED TO IMPLIED WARRANTIES OF MERCHANTABILITY AND FITNESS FOR A PARTICULAR PURPOSE. RAYPAK'S SOLE LIABILITY AND THE SOLE REMEDY AGAINST RAYPAK WITH RESPECT TO DEFECTIVE PARTS SHALL BE AS PROVIDED IN THIS WARRANTY. IT IS AGREED THAT RAYPAK SHALL HAVE NO LIABILITY, WHETHER UNDER THIS WARRANTY, OR IN CONTRACT, TORT, NEGLIGENCE OR OTHERWISE, FOR ANY SPECIAL, CONSEQUENTIAL, OR INCIDENTAL DAMAGE, INCLUDING DAMAGE FROM WATER LEAKAGE. Some states do not allow limitations on how long an implied warranty lasts, or for the exclusion of incidental or consequential damages. So the above limitation or exclusion may not apply to you.

This Limited Warranty gives you specific legal rights. You may also have other rights which may vary from state to state. We suggest that you complete the information below and retain this certificate in the event warranty service is needed. Reasonable proof of the effective date of the warranty (date of installation) must be presented, otherwise, the effective date will be based on the date of manufacture plus thirty (30) days.



www.raypak.com

Raypak, Inc., 2151 Eastman Avenue, Oxnard, CA 93030 (805) 278-5300 FAX: (800) 872-9725
Raypak Canada LTD, 2805 Slough Street, Mississauga, Ontario, Canada L4T 1G2 (905) 677-7999 FAX: (905) 677-8036
Raypak Australia Pty. Ltd, 7 Geddes Street, Mulgrave, Victoria, Australia 3170 (613) 9560 4944 FAX: (613) 9560-4974
8/98 Litho in U. S. A.