

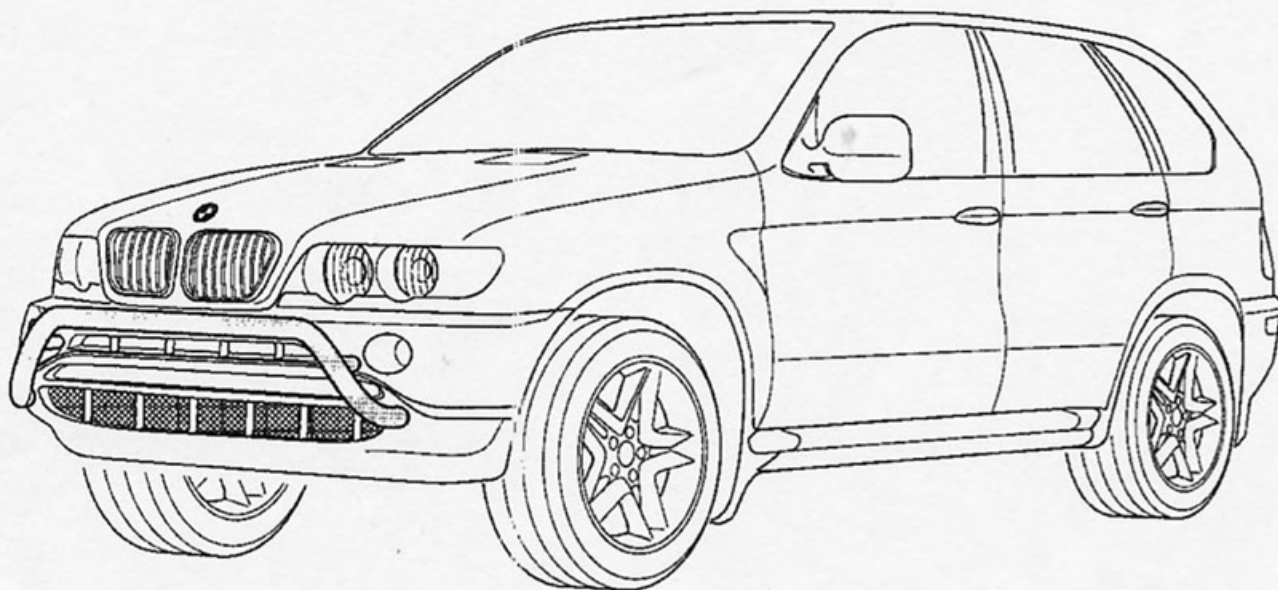

# Parts and Accessories Installation Instructions



F 53 0271 B

---

## Installation Kit for BMW Accessories - Front Bar

### BMW X5 (E53)

Only valid for vehicles with standard bumper

Specialised and electrical knowledge is required.  
Installation time approx. 2 hours, which can vary according to the condition  
and fittings of the vehicle.

Retrofit / Installation kit No. 51 10 0 018 007 (primed version)

**Contents**

Chapter	Page
1. Important notes on installing front bar .....	1
2. Preparations .....	2
3. Parts overview.....	3
4. Mount front bar .....	4
5. Templates for front bar .....	8

## 1. Important notes on installing front bar

Only intended for use within the BMW Dealer Organisation.

The front bar may only be installed by a specialist workshop that has the required special tools and manuals (servicing, repair, diagnostics, etc.).

 The primed front bar must be checked to ensure it fits correctly before it is painted. ◀

### Safety instructions

Make sure that the identification plate or the information stamped into the front bar is not destroyed or made illegible during mechanical machining or by painting.

 The front bar has no protective function for the vehicle. ◀

 The vehicle must not be towed by the front bar. ◀

**The item numbers only refer to the exploded views or to the texts in the related illustration.**

### Painting notes

 Following the painting instructions in the BMW painting manual. The front bag is supplied primed and must undergo the appropriate pre-treatment. ◀

### Subject to technical changes

#### Required tools and aids

1/2 inch socket wrench set  
1/4 inch socket wrench set  
Set of Phillips screwdrivers  
Files

Electric drill  
Drill bit set  
Stepped drill bits  
Pneumatic saw

## 2. Preparations

	<b>TIS AW No.</b>
Conduct brief test	
Disconnect battery	12 00 ...
Remove bumper	51 11 156
Remove front fog lamps	63 17 000

### 3. Parts overview

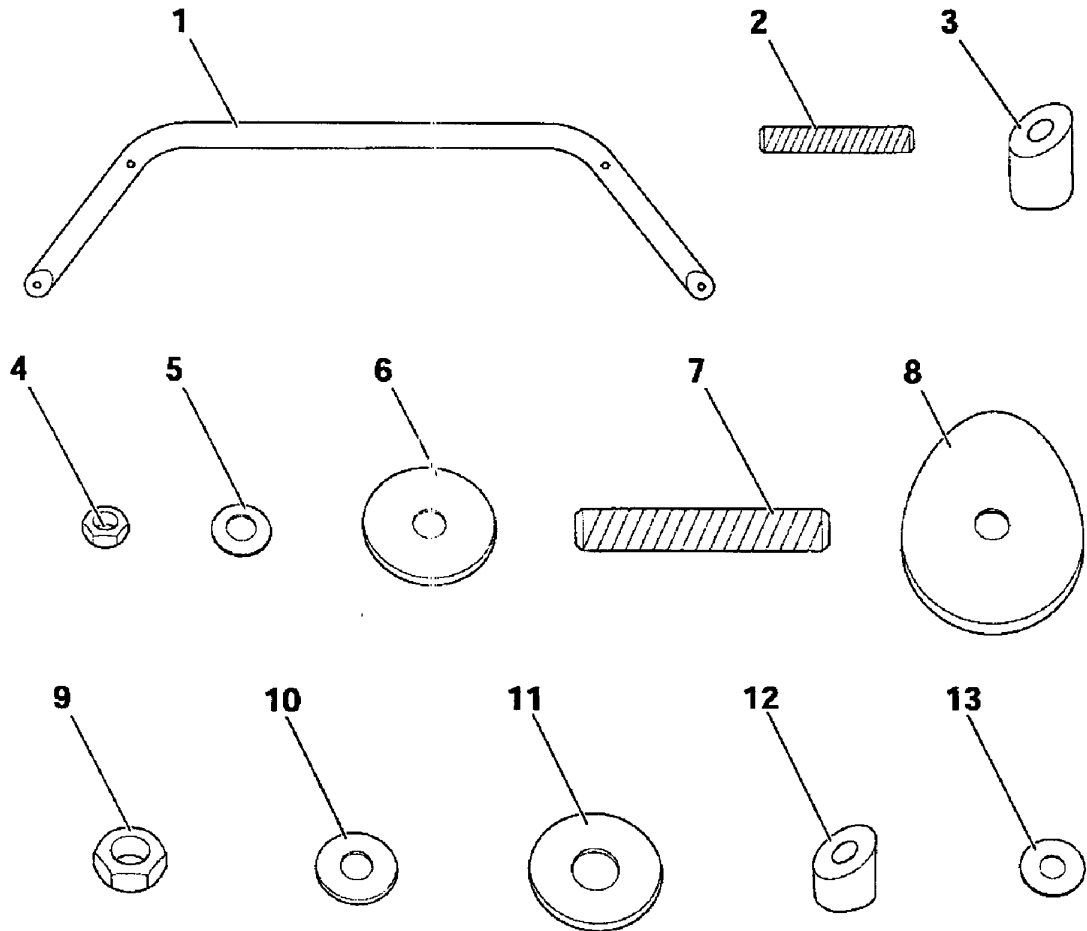

F 53 0272 B

- 1 Front bar
- 2 Grub screw M6 x 70 (2x)
- 3 Spacer rubber, diameter 15 x 25 mm (2x)
- 4 Hexagonal lock nut M6 DIN 985 (2x)
- 5 Washer, diameter 6.4 x 14 mm (2x)
- 6 Washer, diameter 60 x diameter 7 mm x 2 mm (2x)
- 7 Grub screw M8 x 50 (2x)
- 8 Expanded rubber washer (2x)
- 9 Hexagonal lock nut M8 DIN 985 (2x)
- 10 Washer, diameter 8.4 x 25 mm (2x)
- 11 Washer, diameter 60 x diameter 9 mm x 2 mm (2x)
- 12 Spacer, diameter 20 x diameter 9 mm x 12 mm (2x)
- 13 Washer, diameter 25 x diameter 6.5 mm x 1.25 mm (4x)

#### 4. Mount front bar

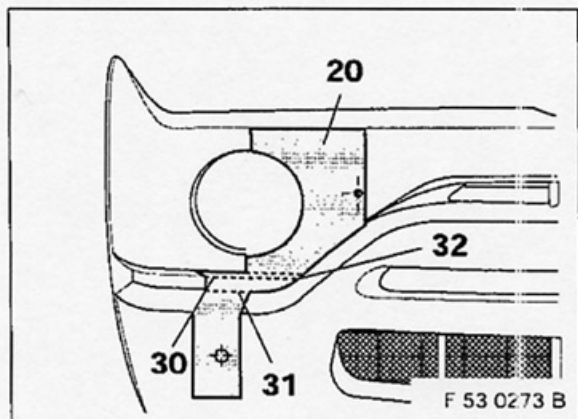

▶ Remount the outer mouldings on the left and right. Remove the license plate and license plate amplifier. ◀

Cut out the right-hand template (20). Begin with Line II (30) and Line III (31) and position the template exactly in the left-hand corner (32) of the recess of the trim panel. Then glue on the template without folds (Line II (30) is the reference line).

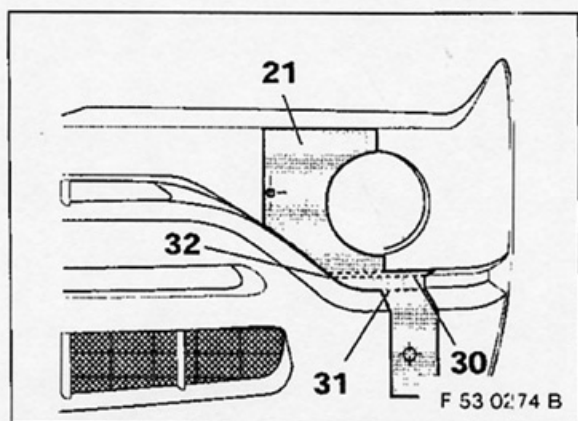

Cut out the left template (21). Start with line II (30) and line III (31) and put the template precisely at the left corner (32) of the depression of the cover and then stick the template on without making creases. (Line II (30) is the leader line).

4. Mount front bar

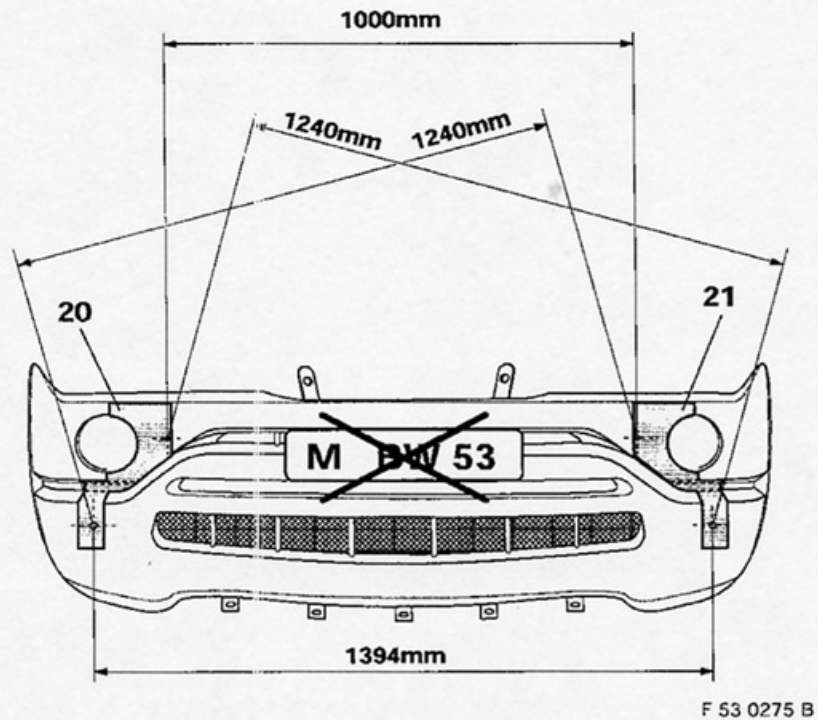

Check the proper positioning of the right-hand template (20) and the left-hand template (21) with the dimensions shown in the illustration. Align the templates (20 and 21) if necessary.

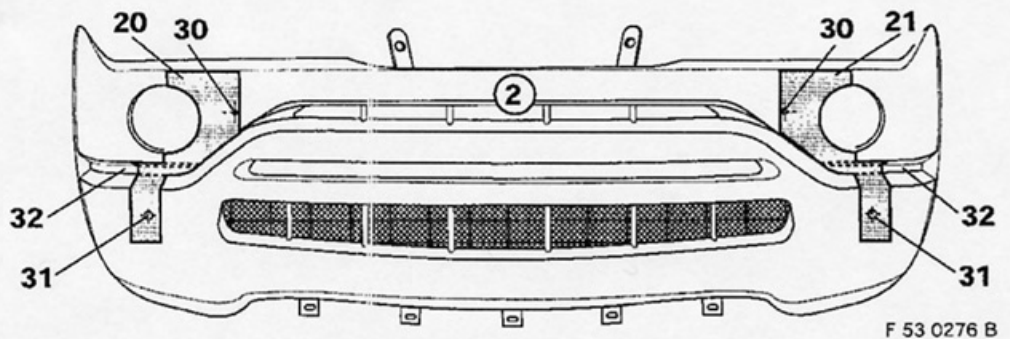

Drill the holes 8 mm dia. (30) and the holes 20 mm dia. (31) in the front apron (2) and deburr the holes.  
Remove the templates (20 and 21).  
Remove the outer moulding strips.

4. Mount front bar

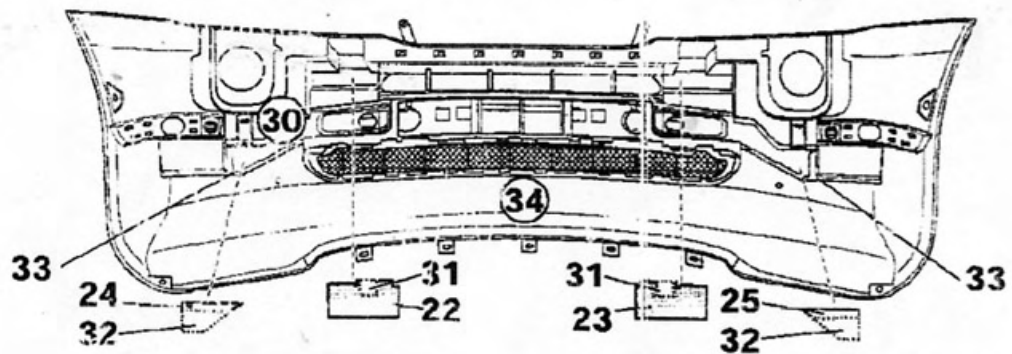

F 53 0277 B

Glue the template for the upper left plastic spacer (22) and the template for the upper right plastic spacer (23) onto the plastic spacer (30) as illustrated. Cut out the plastic spacer (30) along the marked lines (31) with a pneumatic saw and deburr. Glue the template for the lower left plastic spacer (24) and the template for the lower right plastic spacer (25) onto the plastic spacer (30) as illustrated. Cut out the plastic spacer (30) along the marked lines (32) with a pneumatic saw and deburr. Cut out the Styrofoam (33) beneath like the plastic spacer (30).

 The bumper (34) must not be damaged. ◀

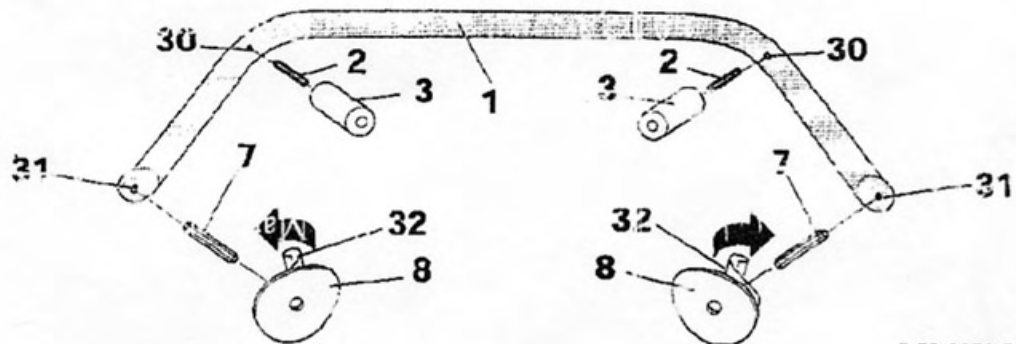

F 53 0278 B

Screw the two M6x70 set screws (2) into the existing M6 threaded holes (30) in the front bar (1) and push on the 15 mm dia. x 25 mm spacer rubber (3). Screw the two M8x50 set screws (7) into the existing M8 threaded holes (31) in the front bar (1). Pull the protective foil (32) off the cellular rubber disks (8) and glue the cellular rubber disks (8) onto the underside of the front bar (1).

 Screw in the set screws approx. 15 mm. ◀



#### 4. Mount front bar

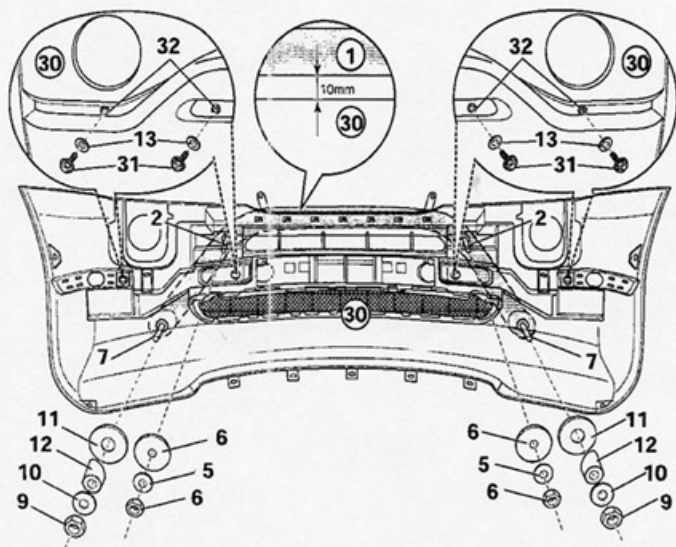

F 53 0279 B

Insert the pre-assembled bar (1) into the holes of the bumper (30) front the front and push the two 60 mm dia. x 7 mm washers (6) onto the M6x70 set screws (2).

Push the two 2.4 mm dia. washers (5) onto the M6x70 set screws (2) and screw on with the M6 self-locking hexagon nuts (4).

Push the two 60 mm dia. x 9 mm washers (11) onto the M8x50 set screws (7).

Push the two 20 mm dia. x 12 mm spacers (12) onto the M8x50 set screws (7) with the angled side toward the bumper.

Push the two 8.4 mm dia. washers (10) onto the M8x50 set screws (8) and screw on with the M8 self-locking hexagon nuts (9).

 Make sure that a uniform distance of 10 mm is maintained between the front bar (1) and the bumper (30) (adjustment is carried out via the M8 self-locking hexagon nuts (9)). ◀

Mount bumper.

 Push the four 25 mm dia. x 6.5 mm dia. washers (13) onto the four M6x18 hexagon bolts (31) and screw into the M6 thread (32). ◀

#### Final work

Screw the cover onto inside of the left and right wheel housing.

Adjust the front fog lamps.

Adjusting the headlight washer system (if present).