

HIGH EFFICIENCY COMMERCIAL CONDENSING BOILERS



SMART SYSTEM™

OPERATING CONTROL FEATURING
A BUILT-IN CASCADING SEQUENCER

5 MODELS: 399,000 – 800,000 BTU/HR

FIRING RATE MODULATION TO 5:1

LESS THAN 20 ppm NOx

DIRECT-VENT FLEXIBILITY TO 100 FEET



**UP TO 94.6%
THERMAL EFFICIENCY**



lochinvar.com



THE SMARTEST CHOICE FOR CONDENSING BOILER PERFORMANCE

The KNIGHT® XL, engineered with Lochinvar's exclusive SMART SYSTEM™ control and an array of other innovative features, places it far ahead of any commercial heating boiler in its class. It promises and delivers ultimate ease of installation and maintenance. With up to 94.6% thermal efficiency, low-NOx emissions and a fully modulating burner, it is the best "green choice" for today's environmentally focused market.

Five modulating/condensing stainless steel KNIGHT XL boilers are available, with 399,000–800,000 Btu/hr inputs, with remarkably small space-saving footprints. All are equipped for direct-vent installation with air intake and exhaust runs up to 100 feet using PVC, CPVC or AL29-4C venting materials. This range of choices is ideal for light-duty applications such as small hotels, schools and office buildings. For higher-demand applications, up to eight KNIGHT XL units can be installed utilizing the built-in cascading sequencer to deliver up to 6.4 million Btu/hr heating capacity.

THE KNIGHT XL BOILER reflects Lochinvar's constant commitment to providing all the options you need to serve every application.

THE KNIGHT XL COMBUSTION SYSTEM

ADVANCED NEGATIVE REGULATION TECHNOLOGY

KNIGHT XL safely and reliably operates with supply gas pressure as low as 4 inches water column, as Negative Regulation (Neg/Reg) technology automatically adjusts fan speed that ensures the correct volume and mix of fuel and air throughout the firing range.

"FAIL-SAFE" DIRECT-SPARK IGNITION

With each call for heat, two electrodes ignite the fuel/gas mixture. A third electrode then senses for flame. SMART SYSTEM will lock out and display the fault if ignition does not occur.

TWO-IN-ONE STAINLESS STEEL HEAT EXCHANGER

A combined primary and secondary heat exchanger captures flue gas heat and allows entering water temperatures as low as 50°F. The stainless steel, pH-tolerant design features a weld-sealed assembly with no O-rings or gaskets, and does not require special glycol. ASME Section IV approved and stamped.

FULLY MODULATING BURNER

The SMART SYSTEM allows fully modulating combustion with 5:1 turndown. The burner can fire as low as 20% of maximum input, and modulates the firing rate up to 100% as demand increases. The burner is a single stainless steel assembly covered with woven steel mesh, and fires in a 360° pattern along the entire length of the primary heat exchanger. This allows the compact KNIGHT XL to exceed the capacity of units with larger multiple burners.

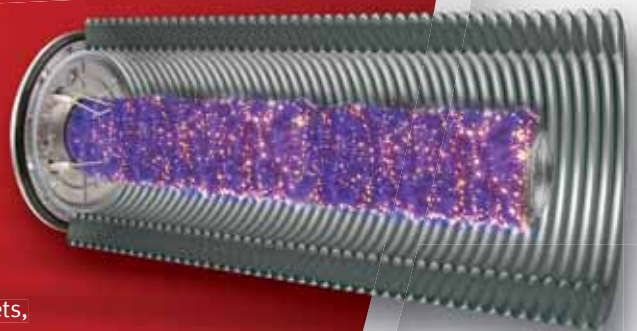

SMART

THE BRAIN THAT DRIVES BRILLIANT PERFORMANCE!

SMART SYSTEM provides unequalled control and monitoring functions that are easy to understand and use.

2-LINE, 16-CHARACTER LCD DISPLAY

Setup and diagnostic information in words, not codes

PASSWORD SECURITY

Dual password levels for installer and user

BUILDING MANAGEMENT SYSTEM CONTROL (0 – 10 V)

BMS-driven input for control of modulation rate or temperature

PC CONNECTION

Can be used with KNIGHT XL PC software to program and troubleshoot SMART SYSTEM functions, and to track historical data, including faults, trends and energy consumption

OUTDOOR RESET

Outdoor temperature monitor guides the reset schedule to meet heat loss/load of the building

NIGHT SETBACK

Program a setback for any time of the day, each day of the week

SYSTEM PUMP CONTROL AND BOILER PUMP CONTROL

Switching contacts control power to both system and boiler pumps on a call for heat. Programmable pump delay orders pumps to operate after a call has been satisfied

PUMP RELAY WITH FREEZE PROTECTION

Ensures water temperature does not fall below 40°F

HOT WATER GENERATOR COMPATIBILITY

One boiler in a sequence can be assigned for Domestic Hot Water Prioritization (DHWP) to meet domestic water demand

INLET/OUTLET AND SYSTEM TEMPERATURE SENSORS

Installer can select which sensor controls the setpoint

LOW WATER FLOW INDICATOR

Protects against high temperature differential in the heat exchanger with reduced firing rate or shutdown

PRODUCT SERVICE INDICATOR

Program reminders for cycle count, operation hours or last service

FIELD CONNECTION VERSATILITY

User-friendly terminal strip allows for 28 low-voltage field connections. Plus 4 line voltage connections supply power to the unit, and up to 3 pumps operated by the SMART SYSTEM



15-1/2"

zero clearance
to combustibles

The 4-unit installation shown illustrates the space-saving KNIGHT XL footprint, and the ease and versatility of the two-pipe direct-vent design.

SYSTEMTM

INCLUDING A BUILT-IN CASCADING SEQUENCER!



In commercial buildings requiring a multiple boiler system, modulating operation of individual units should be sequenced so that the system functions as an integrated whole.

SMART SYSTEM includes a built-in cascading sequencer for up to 8 KNIGHT XL units. This eliminates the initial cost and labor required with installation of a separate sequencer. And, because it's engineered specifically for Lochinvar boilers, it removes any uncertainty about using a "third-party" sequencer, to ensure precise, dependable cascading operation.

When utilizing the built-in cascading sequencer, KNIGHT XL boilers communicate through a simple 2-wire daisy chain connection. On demand, one boiler in the system functions as the leader, and modulates with demand to capacity. The additional load then "cascades" to the second boiler, which fires and modulates to meet added demand via a patented process to match system load and reduce equipment short cycling.



Cascading continues as additional boilers fire in sequence, until all units are in operation or demand is satisfied. When demand drops, the patented cascading process reverses, with the precision, control and performance you expect from Lochinvar.

SMART SYSTEM also controls Lead-Lag Rotation. Every 24 hours the lead boiler role is shifted to the next unit in the sequence. This rotation ensures long life by distributing "lead-lag" runtimes equally over each unit in the system.

EASY HANDLING ON THE JOBSITE

Because of its compact design and stainless steel heat exchanger, KNIGHT XL boilers are remarkably lightweight and easy to handle on the jobsite.

DIRECT-VENTING UP TO 100 FEET

KNIGHT XL offers tremendous flexibility for placement of units within the building, because it permits direct-vent air intake and exhaust runs up to 100 equivalent feet using either PVC, CPVC or AL29-4C stainless steel vent pipe. Intake and exhaust runs can terminate horizontally through a sidewall or vertically through the roof.

EASY ACCESS TO INTERNAL COMPONENTS

The front and top panels of the KNIGHT XL boiler can be quickly removed without any tools. This provides fast, easy access to internal components and electrical connections during installation and service.



KNIGHT® XL BOILER DIMENSIONS AND SPECIFICATIONS

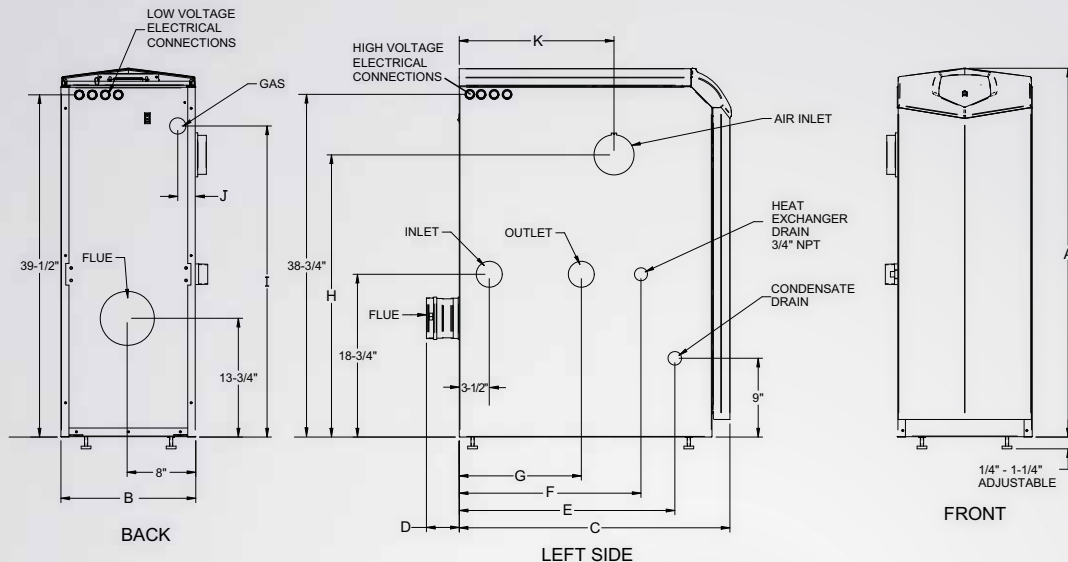

Model Number Guide			
KB	N	700	M13
Model	Natural Gas	Btu/hr Input	Firing Controls

Knight XL Boiler,
Natural Gas,
700,000 Btu/hr input,
M13 firing controls

KNIGHT XL HEATING BOILER

Model Number	Input		Thermal Efficiency	Output MBH	Net I=B=R MBH
	Min MBH	Max MBH			
KBN399	80	399	93.3%	372	324
KBN500	100	500	93.3%	467	406
KBN600	120	600	94.6%	567	493
KBN700	140	700	94.3%	660	574
KBN800	160	800	94.0%	752	654

DIMENSIONS AND SPECIFICATIONS

A	B	C	D	E	F	G	H	I	J	K	Gas Conn.	Water Conn.	Air Inlet	Vent Size	Shipping Wt. (lbs.)
42-1/2"	15-1/2"	27-3/4"	3-3/4"	20-3/4"	21"	14"	34"	34"	2"	18-3/4"	1"	1-1/2"	4"	4"	280
42-1/2"	15-1/2"	31-1/4"	3-3/4"	25-1/2"	21"	14"	32-1/2"	36"	2"	18"	1"	1-1/2"	4"	4"	310
42-1/2"	15-1/2"	36-1/4"	3-3/4"	25"	21"	14"	36"	32-3/4"	5-1/2"	19-1/2"	1"	2"	4"	4"	340
42-1/2"	15-1/2"	40-1/4"	3-3/4"	29"	23"	17"	36"	32-3/4"	3-1/4"	23-1/2"	1"	2"	4"	6"	370
42-1/2"	15-1/2"	45-1/4"	3-3/4"	33-1/4"	23"	17"	36"	32-3/4"	3-1/4"	27-3/4"	1"	2"	4"	6"	405

Notes: Change 'N' to 'L' for L.P. Gas Model. No deration on L.P. models. Performance data based on manufacturer test results. 120 VAC /15 AMP circuit required. All dimensions shown in inches.

STANDARD FEATURES

- Up to 94.6% Thermal Efficiency
- Modulating Burner with 5:1 Turndown
 - Direct-Spark Ignition
 - Low NOx Operation
 - Sealed Combustion
 - Low Gas Pressure Operation
- Vertical & Horizontal Direct-Vent
 - Category IV venting up to 100 feet
 - PVC, CPVC or AL29-4C Venting up to 100 Feet
 - Factory Supplied Sidewall Vent Termination
- ASME Stainless Steel Heat Exchanger
 - ASME Certified, "H" Stamped
 - Gasketless Heat Exchanger
 - 160 psi Working Pressure
 - Highly efficient, condensing design
 - On/Off Switch
 - Adjustable High Limit w/ Manual Reset
 - Flow Switch
 - Inlet & Outlet Temperature Sensors
 - Flue Temperature Sensor
 - Low Air Pressure Switch
 - 50 psi ASME Relief Valve
 - Temperature & Pressure Gauge
 - Adjustable Leveling Legs
 - Condensate Trap
 - Zero Clearances to Combustible Material
 - 10 Year Limited Warranty (See Warranty for Details)

SMART SYSTEM FEATURES

- SMART SYSTEM Digital Operating Control
 - 2 line, 16 Character Display
 - Dual Level Password Security
 - Domestic Hot Water Prioritization
 - Built in Cascading Sequencer for up to 8 Boilers
 - Building Management System Integration with 0-10 VDC Input
 - Outdoor Reset Control with Outdoor Air Sensor
 - Low Water Flow Safety Control & Indication
 - Inlet & Outlet Temperature Readout
 - Freeze Protection
 - Service Reminder
 - Time Clock
- Data Logging
 - Hours Running, Space Heating
 - Hours Running, Domestic Hot Water
 - Ignition Attempts
 - Last 10 Lockouts
- Programmable System Efficiency Optimizers
 - Night Setback
 - Anti-Cycling
 - Outdoor Air Reset Curve
 - Ramp Delay
 - Boost Temperature & Time
- Three Pump Control
 - System Pump
 - Boiler Pump
 - Domestic Hot Water Pump
- High Voltage Terminal Strip
 - 120 VAC / 50-60 Hertz / 1 Phase Power Supply
 - Three sets of Pump Contacts with Pump Relays

- Low Voltage Terminal Strip
 - 24 VAC Auxiliary Device Relay
 - Auxiliary Proving Switch Contacts
 - Flow Switch Contacts
 - Alarm on Any Failure Contacts
 - Runtime Contacts
 - DHW Thermostat Contacts
 - Room Thermostat Contacts
 - System Sensor Contacts
 - DHW Tank Sensor Contacts
 - Outdoor Air Sensor Contacts
 - Cascade Contacts
 - 0-10 VDC BMS External Control Contact

OPTIONAL EQUIPMENT

- Alarm Bell on Any Failure
- Condensate Neutralization Kit
- High & Low Gas Pressure Switches w/ Manual Reset (KB500-KB800)
- Low Water Cutoff w/Manual Reset & Test
- SMART SYSTEM PC Software
- Stainless Steel Vent Kits (KB700-KB800)
- Multi-Stack Frame

FIRING CODES

- M9 Standard Construction
- M7 California Code
- M13 CSD1 / FM / GE Gap (KB500-KB800)



Patent # 7,506,617

