



Service Manual

Models: 400 - 801



⚠ WARNING

This manual must only be used by a qualified heating installer / service technician. Read all instructions, including this manual and the Knight XL Installation and Operation Manual, before installing. Perform steps in the order given. Failure to comply could result in severe personal injury, death, or substantial property damage.



Save this manual for future reference.

Contents

CONTENTS	2	2. MAINTENANCE	
Hazard Definitions	2	Maintenance and Annual Startup	28-32
PLEASE READ BEFORE PROCEEDING	3	3. TROUBLESHOOTING	
Handling Ceramic Fiber Materials	3	Before Troubleshooting	33
When servicing boiler	4	Check Control Module Fuses	33
Boiler operation	4	Table 3-1 - Troubleshooting Chart - No Display	34
Boiler water	4	Checking Temperature Sensors	35
Freeze protection fluids	4	Table 3-3 - Troubleshooting Chart - Noisy System	36
WHAT IS IN THIS MANUAL	5	Table 3-4 - Troubleshooting Chart - Fault Messages	37-43
1. SERVICE		Combustion Analysis Procedure	44
Near Boiler Piping	6	Table 3-5 - Troubleshooting Chart - Combustion Levels	44
The Knight XL Display	7	Table 3-6 - Flue Products	44
Control Inputs	8	Gas Valve Adjustment Procedure	45
Control Outputs	9	Revision Notes	Back Cover
General Operation	10		
Sequence of Operation	11-12		
Display Panel Menu Access	13		
Display Panel Parameter Access	14		
Parameter Table	15-18		
Viewable and Changeable Control Parameters	19-27		

Hazard definitions

The following defined terms are used throughout this manual to bring attention to the presence of hazards of various risk levels or to important information concerning the life of the product.

DANGER

DANGER indicates an imminently hazardous situation which, if not avoided, will result in death or serious injury.

WARNING

WARNING indicates a potentially hazardous situation which, if not avoided, could result in death or serious injury.

CAUTION

CAUTION indicates a potentially hazardous situation which, if not avoided, may result in minor or moderate injury.

CAUTION

CAUTION used without the safety alert symbol indicates a potentially hazardous situation which, if not avoided, may result in property damage.

NOTICE

NOTICE indicates special instructions on installation, operation, or maintenance that are important but not related to personal injury or property damage.

Please read before proceeding

⚠ WARNING

Installer – Read all instructions, including this manual and the Knight XL Installation and Operation Manual, before installing. Perform steps in the order given.

User – This manual is for use only by a qualified heating installer/service technician. Refer to the Knight XL User’s Information Manual for your reference.

Have this boiler serviced/inspected by a qualified service technician at least annually.

Failure to comply with the above could result in severe personal injury, death or substantial property damage.

NOTICE

When calling or writing about the boiler – Please have the boiler model and serial number from the boiler rating plate.

Consider piping and installation when determining boiler location (see the Knight XL Installation and Operation Manual).

Any claims for damage or shortage in shipment must be filed immediately against the transportation company by the consignee.

Handling ceramic fiber materials

REMOVAL OF COMBUSTION CHAMBER LINING

⚠ WARNING

The combustion chamber insulation in this appliance contains ceramic fiber material. Ceramic fibers can be converted to cristobalite in very high temperature applications. The International Agency for Research on Cancer (IARC) has concluded, “Crystalline silica inhaled in the form of quartz or cristobalite from occupational sources is carcinogenic to humans (Group 1).” Normal operating temperatures in this appliance are below the level to convert ceramic fibers to cristobalite. Abnormal operating conditions would have to be created to convert the ceramic fibers in this appliance to cristobalite.

The ceramic fiber material used in this appliance is an irritant; when handling or replacing the ceramic materials it is advisable that the installer follow these safety guidelines.

- Avoid breathing dust and contact with skin and eyes.
 - Use NIOSH certified dust respirator (N95). This type of respirator is based on the OSHA requirements for cristobalite at the time this document was written. Other types of respirators may be needed depending on the job site conditions. Current NIOSH recommendations can be found on the NIOSH website at <http://www.cdc.gov/niosh/homepage.html>. NIOSH approved respirators, manufacturers, and phone numbers are also listed on this website.
 - Wear long-sleeved, loose fitting clothing, gloves, and eye protection.
- Apply enough water to the combustion chamber lining to prevent airborne dust.
- Remove the combustion chamber lining from the appliance and place it in a plastic bag for disposal.
- Wash potentially contaminated clothes separately from other clothing. Rinse clothes washer thoroughly.

NIOSH stated First Aid.

- Eye: Irrigate immediately.
- Breathing: Fresh air.

Please read before proceeding

When servicing boiler –

- To avoid electric shock, disconnect electrical supply before performing maintenance.
- To avoid severe burns, allow boiler to cool before performing maintenance.

Boiler operation –

- Do not block flow of combustion or ventilation air to the boiler.
- Should overheating occur or gas supply fail to shut off, do not turn off or disconnect electrical supply to circulator. Instead, shut off the gas supply at a location external to the appliance.
- Do not use this boiler if any part has been under water. The possible damage to a flooded appliance can be extensive and present numerous safety hazards. Any appliance that has been under water must be replaced.

Boiler water –

- Thoroughly flush the system (without boiler connected) to remove sediment. The high-efficiency heat exchanger can be damaged by build-up or corrosion due to sediment.
- Do not use petroleum-based cleaning or sealing compounds in the boiler system. Gaskets and seals in the system may be damaged. This can result in substantial property damage.
- Do not use “homemade cures” or “boiler patent medicines”. Serious damage to the boiler, personnel, and/or property may result.
- Continual fresh make-up water will reduce boiler life. Mineral buildup in the heat exchanger reduces heat transfer, overheats the stainless steel heat exchanger, and causes failure. Addition of oxygen carried in by makeup water can cause internal corrosion. Leaks in boiler piping must be repaired at once to prevent the introduction of makeup water.

Freeze protection fluids –

- NEVER use automotive antifreeze. Use only inhibited propylene glycol solutions which are specifically formulated for hydronic systems. Ethylene glycol is toxic and can attack gaskets and seals used in hydronic systems.

What is in this manual?

Service

Near boiler piping

- Typical system components

The Knight XL display

- Display panel readout, buttons and their functions

Control module inputs

- Control module inputs and options

Control module outputs

- Control module outputs and options

General

- How the boiler operates
- How the control module operates
- Access modes -- user and installer
- Sequence of operation -- Domestic Hot Water (DHW)/space heating

Control panel menu access

- Accessing programming mode and locating menus (See separate guide covering the interface.)

Control panel parameter access

- Accessing and changing parameters from the display panel

Quick start information -- parameter table

- An index of available adjustments and readouts, where to access them and where to find detailed information.

Knight XL operation

- A: General
- B: Temperature Setting
- C: Data Logging
- D: Functions
- E: DHW Settings
- F: Outdoor Reset
- G: Anti-cycling
- H: Control Modes
- I: Circulation Pumps
- J: Building Management System (BMS)
- K: Service Notification

Maintenance

- Service and maintenance schedules
- Address reported problems
- Inspect boiler area and boiler interior
- Clean condensate trap
- Check all piping for leaks
- Check air openings
- Flue vent system and air piping
- Check water system
- Check expansion tank
- Check boiler relief valve
- Inspect ignition electrode
- Check ignition ground wiring
- Check all boiler wiring
- Check control settings
- Perform start-up and checks
- Check burner flame
- Check flame signal
- Check flue gas temperature
- General maintenance
- Review with owner
- Cleaning boiler heat exchanger
- Oiled bearing circulators

Troubleshooting

- Troubleshooting table - No display
- Checking temperature sensors
- Sensor tables
- Troubleshooting table - Fault messages displayed on boiler interface
- Combustion analysis procedure
- Gas valve adjustment procedure

1 Service

Near boiler piping

This piping reference is included to specify the *Near Boiler Piping* specific to the Knight XL. This piping scheme is important for proper operation of the SMART SYSTEM control. See the Knight XL Installation and Operation Manual for more detailed piping diagrams.

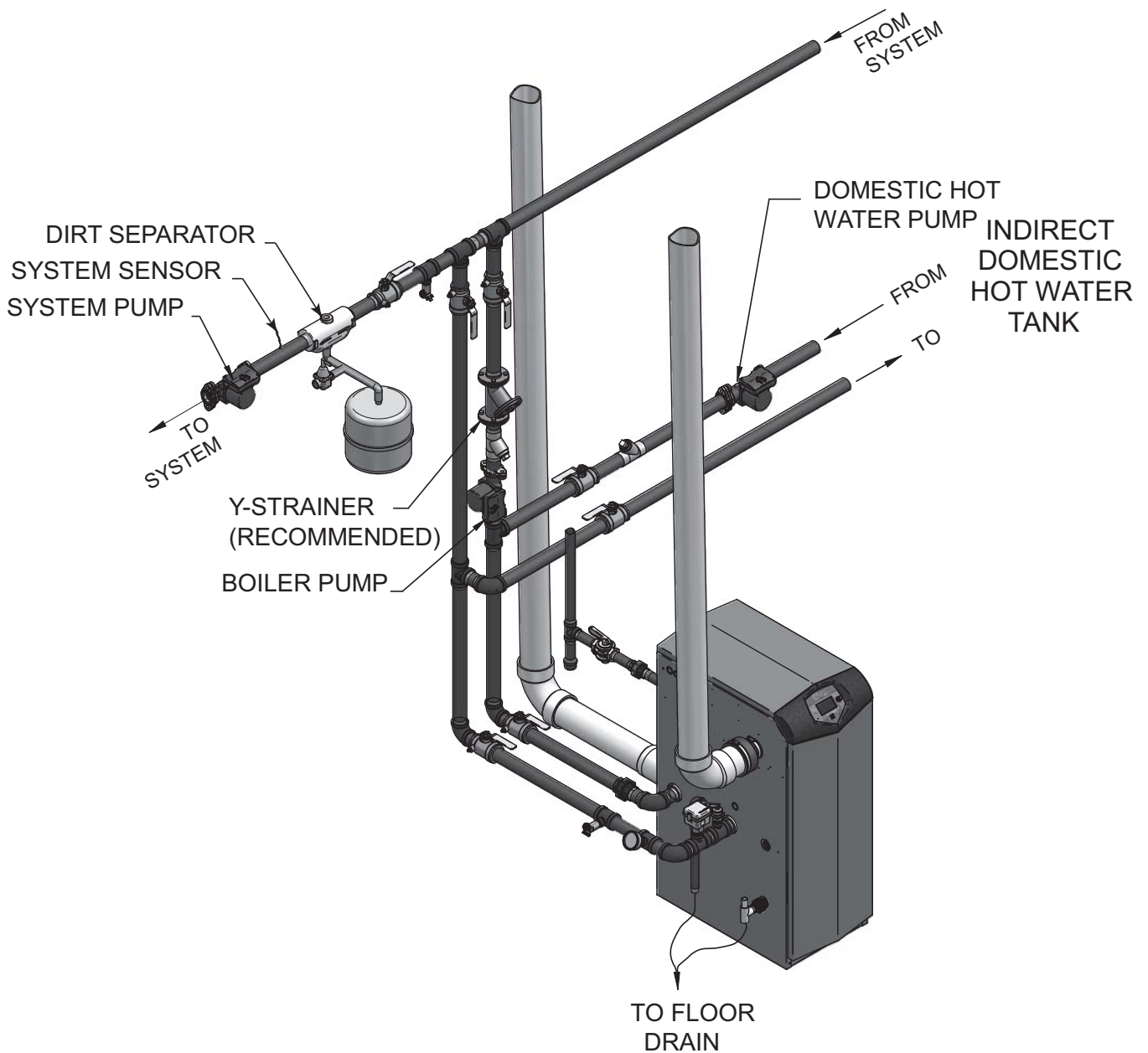

1 Service *(continued)*

The Knight XL display

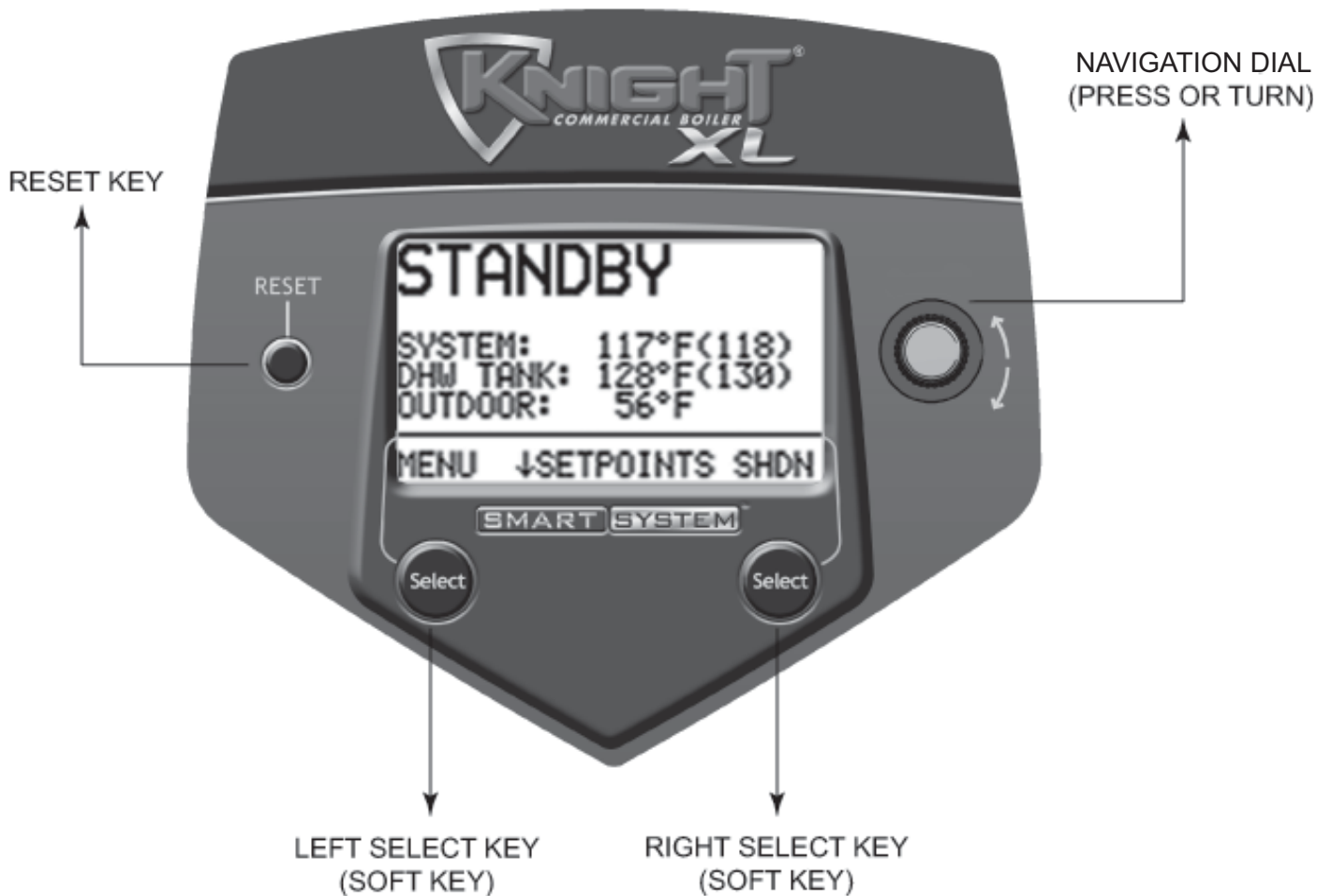

The information on the bottom of the display shows the functions of the two SELECT keys (on either corner), and the NAVIGATION dial (in the center):

MENU = Left SELECT Key

SETPOINTS = NAVIGATION Dial - Pressing Down

SHDN = Right SELECT Key

1 Service

Control inputs

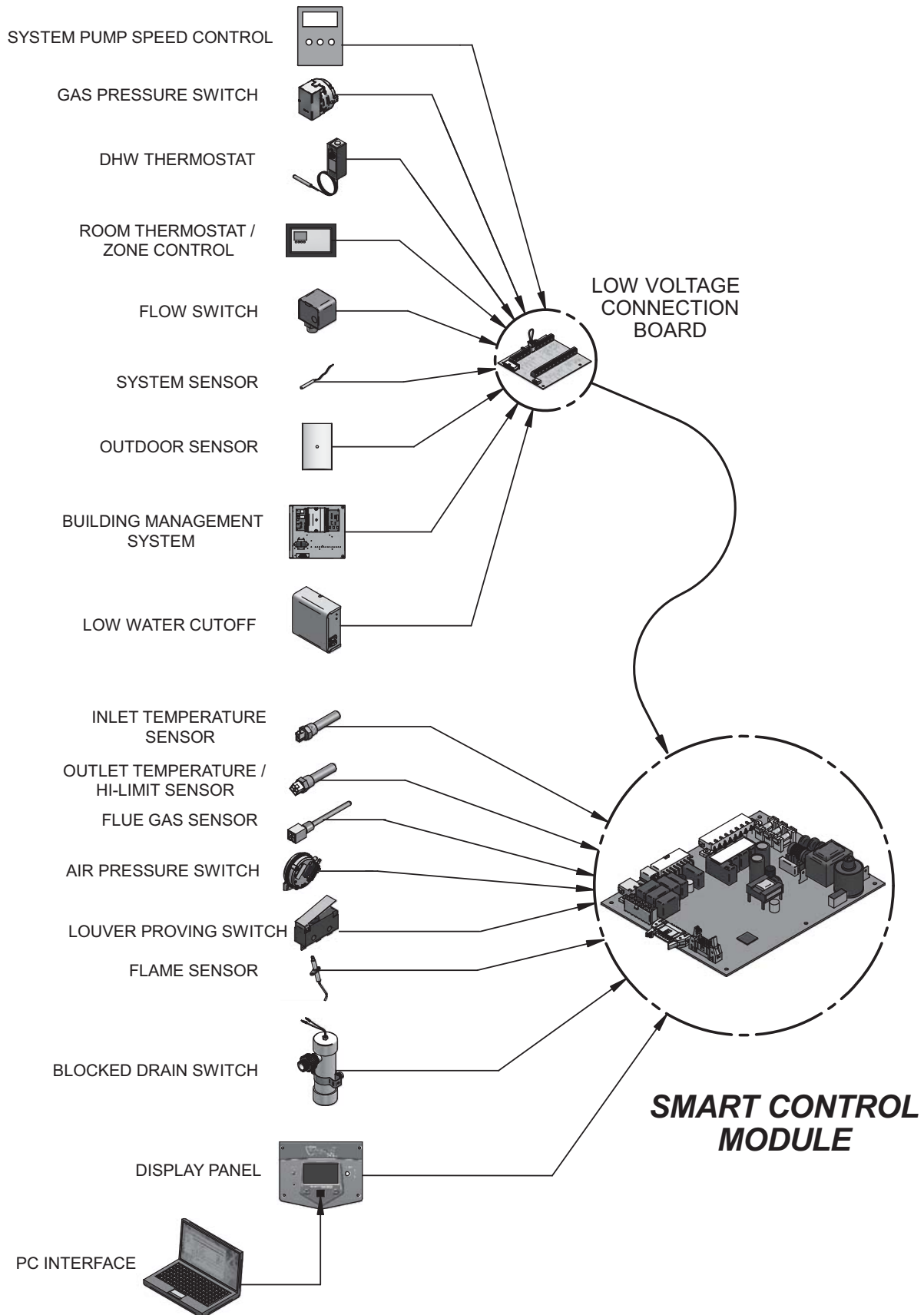

1 Service *(continued)*

Control outputs

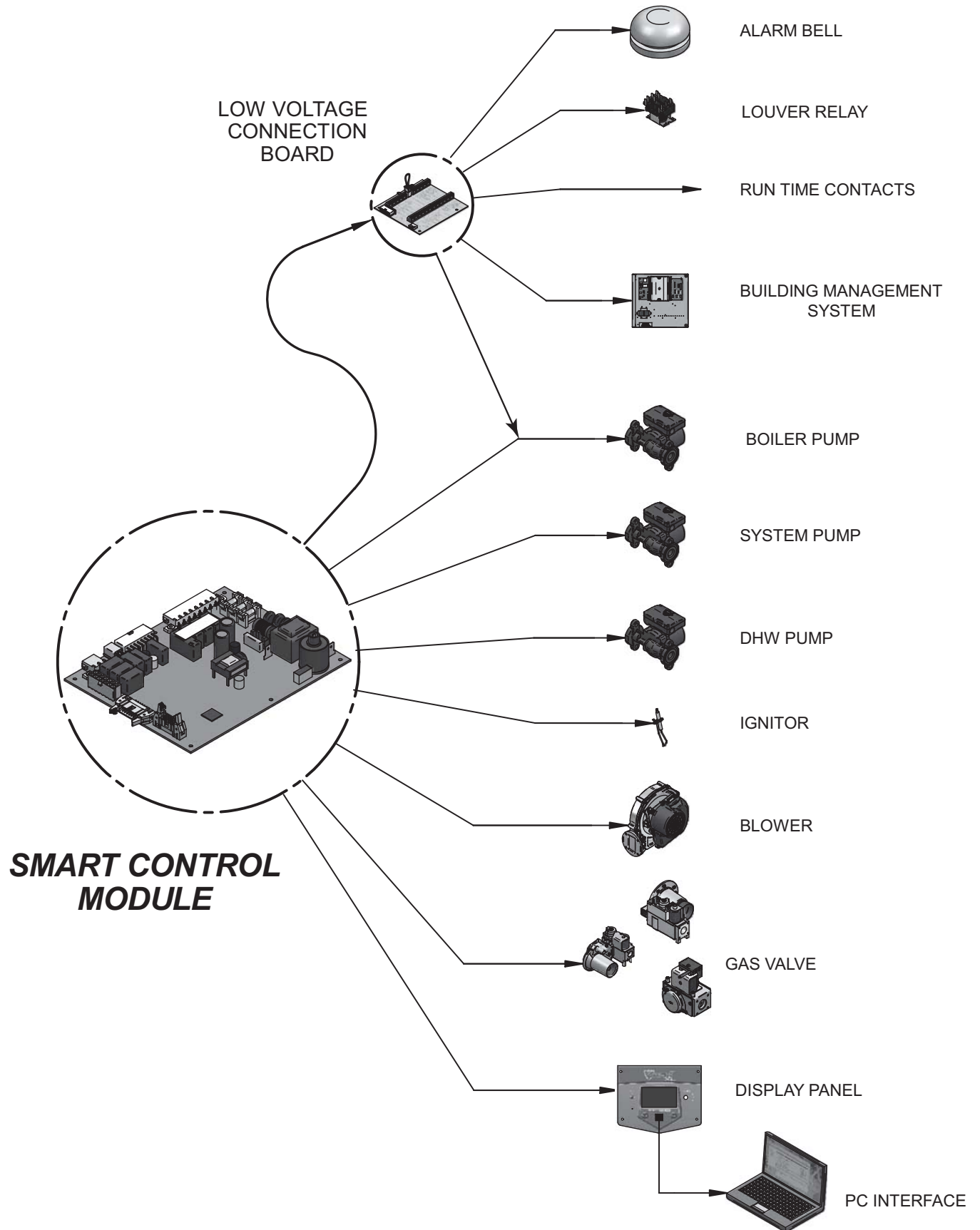

1 Service

General Operation

How the boiler operates

The Knight XL uses an advanced stainless steel heat exchanger and an electronic control module that allows fully condensing operation. The blower pulls in gas and air and pushes flue products out of the boiler through the heat exchanger and flue piping. The control module regulates blower speed to control boiler firing rate. The gas valve senses the amount of air flowing into the boiler and allows only the right amount of gas to flow.

How the control module operates

The Knight XL control module receives input from boiler sensors. The control module activates and controls the blower and gas valve to regulate heat input and switches boiler, DHW and system pumps on and off as needed. The user/installer programs the module to meet system needs by adjusting control parameters. These parameters set operating temperatures and boiler operating modes. Boiler operation can be based on boiler outlet water temperature, boiler return water temperature or system supply temperature, depending on the parameter setting.

Sequence of operation

Table 1-1 shows control module normal sequences of operation for space heating and DHW operation. The combined operation sequence is for a typical application, programmed to provide DHW priority.

Access modes

User

The user can adjust space heating and tank target temperatures by pressing the NAVIGATION dial when “↓SETPOINTS” is flashing at the bottom of the display. The date and time, and the temperature units can also be changed.

Installer

Most parameters are available only to the installer, accessible by entering the installer password (5309).

Saving parameters (reference the Parameter Table - Table 1-4 on pages 15 - 18 of this manual)

NOTICE

Please note that the brackets ([]) denote screen status.

To save parameters and exit programming:

Press the RIGHT SELECT [SAVE] key and then press the RIGHT SELECT [HOME] key.

To enter a parameter and continue programming:

Press the RIGHT SELECT [SAVE] key 1 time to return to the parameter listings; press again to return to the menu listings. Remember to press the RIGHT SELECT [HOME] key when finished programming in order to save the changes made.

1 Service *(continued)*

Table 1-1 Sequence of Operation

OPERATION	DISPLAY
1. Upon a call for heat, the gas pressure switch(es) must be closed.	<pre> START SYSTEM: 116°F TANK: 128°F(125) OUTDOOR: 56°F ----- MENU ↵↵SCREEN SHDN </pre>
2. Once the gas pressure switch(es) are closed, the control turns on the appropriate pumps (system and boiler pumps for space heating, DHW pump for DHW). The flow switch and/or LWCO must close.	<pre> START SYSTEM: 116°F TANK: 128°F(125) OUTDOOR: 56°F ----- MENU ↵↵SCREEN SHDN </pre>
3. The control turns on power to the louver relay. The louver proving switch, air pressure switch, and blocked drain switch must close.	<pre> START SYSTEM: 116°F TANK: 128°F(125) OUTDOOR: 56°F ----- MENU ↵↵SCREEN SHDN </pre>
4. The control starts a 15 second prepurge cycle by initiating the blower.	<pre> PRE-PURGE SYSTEM: 117°F(118) TANK: 128°F(130) OUTDOOR: 56°F ----- MENU ↵↵SCREEN SHDN </pre>
5. The control starts a 4 second trial for ignition by firing the spark electrode and opening the gas valve.	<pre> IGNITION SYSTEM: 117°F(118) DHW TANK: 128°F(130) OUTDOOR: 56°F ----- MENU ↵↵SCREEN SHDN </pre>
6. If flame is not detected within 1 second after the sparking ends, the control will perform a 10 second post-purge, then start another prepurge cycle and try to light the burner again. On the 501 and larger models, the control will lock out if this second attempt also fails. On the 400 model, the control will perform a total of 4 attempts before locking out.	<pre> POST-PURGE SYSTEM: 117°F(118) TANK: 128°F(130) OUTDOOR: 56°F ----- MENU ↵↵SCREEN SHDN </pre>
7. If flame is detected, it holds the firing rate steady for 5 seconds to let the flame stabilize, then it begins to modulate the firing rate based on a set point or some other command (such as a 0-10V BMS signal).	<pre> 42% SYSTEM: 117°F(118) TANK: 128°F(130) OUTDOOR: 56°F ----- MENU ↵↵SCREEN SHDN </pre>

1 Service









Table 1-1 (continued from previous page) *Sequence of Operation*

OPERATION	DISPLAY
8. If the space heating call for heat is active, and the tank thermostat or sensor starts a DHW call for heat, the boiler will switch to the DHW mode. If programmed for normal DHW operation (not as a zone), the DHW pump will turn on first, then the boiler pump will turn off 2 seconds later. This will divert the boiler's outlet water from the heating system and send it to the tank coil instead. The control will then modulate to maintain the outlet temperature to the DHW boiler set point.	<pre> 42% 🔥 1 🔥 SYSTEM: 117°F(118) TANK: 124°F(130) OUTDOOR: 56°F ----- MENU ↵SCREEN SHDN </pre>
9. If the boiler is not part of a Cascade, and both the space heating and DHW calls for heat remain active long enough, the boiler will switch back and forth between the two heating modes until one of them is satisfied.	<pre> 42% 🔥 🏠 🔥 SYSTEM: 117°F(118) TANK: 124°F(130) OUTDOOR: 56°F ----- MENU ↵SCREEN SHDN </pre>
10. Once both calls for heat are satisfied, the control will turn off the burner. The blower will continue to run during a 10 second postpurge.	<pre> POST-PURGE ANTI-CYCLING SYSSYM: 117°F(118) TANK: 124°F(130) OUTDOOR: 56°F ----- MENU ↵SCREEN SHDN </pre>
11. Any pumps that are running will continue to run for their respective pump delay times before turning off, unless programmed to remain on continuously. A 60 second anti-cycle period will start, which will delay any new call for heat until it times out.	<pre> BLOCKED ANTI-CYCLING SYSTEM: 117°F(118) TANK: 124°F(130) OUTDOOR: 56°F ----- MENU ↵SCREEN SHDN </pre>
12. In Standby, ready to start a new cycle.	<pre> STANDBY SYSTEM: 117°F DHW TANK: 128°F(130) OUTDOOR: 56°F ----- MENU ↓SETPOINTS SHDN </pre>

1 Service *(continued)*

Display panel menu access









Table 1-2 Use this procedure to access menus from the display panel

BUTTON	SCREEN STATUS	OPERATION	DISPLAY
	[SHDN]	Press the RIGHT SELECT soft key [SHDN].	STANDBY OUTLET 117°F INLET 128°F <hr/> MENU ↓SETPOINTS SHDN
	[YES]	Press the LEFT SELECT soft key [YES].	STANDBY SHUTDOWN <hr/> YES _____ NO
	[MENU]	Press and hold the LEFT SELECT soft key [MENU] for five (5) seconds.	STANDBY OUTLET 117°F INLET 128°F <hr/> MENU ↓SETPOINTS SHDN
		Rotate the NAVIGATION dial clockwise until 5 is displayed (first digit on the left).	SHUTDOWN PASSWORD 0000 <hr/> EXIT ↓NEXT SAVE
		Press the NAVIGATION dial to select the next digit. Rotate the NAVIGATION dial clockwise until 3 is shown in the display.	SHUTDOWN PASSWORD 5000 <hr/> EXIT ↓NEXT SAVE
		Press the NAVIGATION dial 2 times to move to the last digit. Rotate the NAVIGATION dial counterclockwise until 9 is displayed.	SHUTDOWN PASSWORD 5300 <hr/> EXIT ↓NEXT SAVE
	[SAVE]	Press the RIGHT SELECT soft key [SAVE].	SHUTDOWN PASSWORD 5309 <hr/> EXIT ↓NEXT SAVE
		Rotate the NAVIGATION dial counterclockwise to select a category.	SHUTDOWN >GENERAL TEMPERATURE SETTINGS DATA LOGGING FUNCTIONS <hr/> HOME ↵ SCROLL

1 Service

Display panel parameter access

Table 1-3 This is a typical example of accessing a parameter, shown for parameter Temperature Settings, MIN SH Setpt

BUTTON	SCREEN STATUS	OPERATION	DISPLAY
<p><i>This example shows how to access parameter Temperature Settings. The first display shown is at the beginning of the menu listings, after entering the installer access code.</i></p>			
		Rotate the NAVIGATION dial counterclockwise until the arrow (>) is next to TEMPERATURE SETTINGS .	<pre> SHUTDOWN >GENERAL TEMPERATURE SETTINGS DATA LOGGING FUNCTIONS ----- HOME < > SCROLL </pre>
		Press the NAVIGATION dial one time.	<pre> SHUTDOWN GENERAL >TEMPERATURE SETTINGS DATA LOGGING FUNCTIONS ----- HOME < > SCROLL </pre>
		Rotate the NAVIGATION dial counterclockwise until the arrow (>) is next to MIN SETPT .	<pre> SHUTDOWN SH1 SETPT 180°F MIN SETPT 32°F MAX SETPT 190°F SH1 OFFSET 10°F ----- HOME < > SCROLL </pre>
		Press the NAVIGATION dial one time.	<pre> SHUTDOWN SH1 SETPT 180°F >MIN SETPT 32°F MAX SETPT 190°F SH1 OFFSET 10°F ----- HOME < > SCROLL </pre>
		Rotate the NAVIGATION dial to the desired temperature.	<pre> SHUTDOWN SH1 SETPT 180°F >MIN SETPT 32°F MAX SETPT 190°F SH1 OFFSET 10°F ----- HOME < > SCROLL </pre>
	[SAVE]	Press the RIGHT SELECT soft key [SAVE] one time.	<pre> SHUTDOWN SH1 SETPT 180°F MIN SETPT 32°F MAX SH1 ----- HOME < > SCROLL </pre>
	[EXIT]	Press the LEFT SELECT soft key [EXIT] if all desired changes have been made.	<pre> SHUTDOWN SH1 SETPT 180°F MIN SETPT 32°F MAX SH1 ----- EXIT SAVE </pre>
	[HOME]	Press the LEFT SELECT soft key [HOME].	<pre> SHUTDOWN SH1 SETPT 180°F MIN SETPT 32°F MAX SETPT 190°F SH1 OFFSET 10°F ----- HOME SAVE </pre>

1 Service *(continued)*

Parameter table

Table 1-4 This table lists SMART SYSTEM control module parameters and where to access them

Menu	Sub Item	Description	See Page	User Access		Installer Access		
				Display	Modify	Display	Modify	
GENERAL	A	1	Date and Time	19	Yes	Yes	Yes	Yes
		2	Software Version (read only)	19	No	No	Yes	No
		3	Temperature Units (°C/°F)	19	Yes	Yes	Yes	Yes
		4	SH Night Setback Offset	19	No	No	Yes	Yes
		5	SH Night Setback On Times	19	No	No	Yes	Yes
		6	SH Night Setback Off Times	19	No	No	Yes	Yes
		7	DHW Night Setback Offset	19	No	No	Yes	Yes
		8	DHW Night Setback On Times	19	No	No	Yes	Yes
		9	DHW Night Setback Off Times	19	No	No	Yes	Yes
		10	Display Timeout	20	No	No	Yes	Yes
TEMPERATURE SETTINGS	B	1	SH1 Set Point	20	Yes	Yes	No	No
		2	Minimum SH Set Point	20	No	No	Yes	Yes
		3	Maximum SH Set Point	20	No	No	Yes	Yes
		4	SH1 Offset Set Point	20	No	No	Yes	Yes
		5	SH1 Differential Set Point	20	No	No	Yes	Yes
		6	SH2 Set Point	20	Yes	Yes	No	No
		7	SH2 Offset Set Point	20	No	No	Yes	Yes
		8	SH2 Differential Set Point	20	No	No	Yes	Yes
		9	SH3 Set Point	20	Yes	Yes	No	No
		10	SH3 Offset Set Point	20	No	No	Yes	Yes
		11	SH3 Differential Set Point	20	No	No	Yes	Yes
		12	3-Way Valve Time	20	No	No	Yes	Yes
DATA LOGGING	C	1	Reset Last 10 Errors	20	No	No	Yes	Yes
FUNCTIONS	D	1	Service Mode Delay	20	No	No	Yes	Yes
		2	Freeze Protection Pump On	20	No	No	Yes	Yes
		3	Freeze Protection Burner On	20	No	No	Yes	Yes
		4	Freeze Protection Burner Differential	20	No	No	Yes	Yes

1 Service

Parameter table

Table 1-4 (continued from previous page) This table lists SMART SYSTEM control module parameters and where to access them

Menu	Sub Item	Description	See Page	User Access		Installer Access		
				Display	Modify	Display	Modify	
DHW SETTINGS	E	1	DHW Boiler Set Point	21	No	No	Yes	Yes
		2	DHW Tank Set Point	21	Yes	Yes	Yes	Yes
		3	Tank Set Point Differential	21	No	No	Yes	Yes
		4	Boiler Set Point Offset	21	No	No	Yes	Yes
		5	Boiler Set Point Differential	21	No	No	Yes	Yes
		6	SH/DHW Switching Time	21	No	No	Yes	Yes
		7	DHW/SH Switching Time	21	No	No	Yes	Yes
		8	Tank Minimum Set Point	21	No	No	Yes	Yes
		9	Tank Maximum Set Point	21	No	No	Yes	Yes
		10	DHW Type (Normal, Zone)	21	No	No	Yes	Yes
		11	Fan Speed Limiting for Indirect DHW Tank	21	No	No	Yes	Yes
OUTDOOR RESET	F	1	Low Outdoor Temperature	22	No	No	Yes	Yes
		2	High Outdoor Temperature	22	No	No	Yes	Yes
		3	SH1 Set Point at Low Outdoor Temp	22	No	No	Yes	Yes
		4	SH1 Set Point at High Outdoor Temp	22	No	No	Yes	Yes
		5	Outdoor Air Shutdown SH1	22	No	No	Yes	Yes
		6	Outdoor Air Shutdown Differential SH1	23	No	No	Yes	Yes
		7	Shift Reset Curve SH1	23	No	No	Yes	Yes
		8	SH2 Set Point at Low Outdoor Temp	22	No	No	Yes	Yes
		9	SH2 Set Point at High Outdoor Temp	22	No	No	Yes	Yes
		10	Outdoor Air Shutdown SH2	22	No	No	Yes	Yes
		11	Outdoor Air Shutdown Differential SH2	23	No	No	Yes	Yes
		12	Shift Reset Curve SH2	23	No	No	Yes	Yes
		13	SH3 Set Point at Low Outdoor Temp	22	No	No	Yes	Yes
		14	SH3 Set Point at High Outdoor Temp	22	No	No	Yes	Yes
		15	Outdoor Air Shutdown SH3	22	No	No	Yes	Yes
		16	Outdoor Air Shutdown Differential SH3	23	No	No	Yes	Yes
		17	Shift Reset Curve SH3	23	No	No	Yes	Yes

1 Service *(continued)*

Parameter table

Table 1-4 (continued from previous page) This table lists SMART SYSTEM control module parameters and where to access them

Menu	Sub Item	Description	See Page	User Access		Installer Access		
				Display	Modify	Display	Modify	
OUTDOOR RESET	F	18	Boost Temperature	23	No	No	Yes	Yes
		19	Boost Time	23	No	No	Yes	Yes
ANTI-CYCLING	G	1	Anti-Cycling Time	23	No	No	Yes	Yes
		2	Anti-Cycling Override Differential	23	No	No	Yes	Yes
		3	Ramp Delay (Enable, Disable)	23	No	No	Yes	Yes
		4	SH Ramp Delay	24	No	No	Yes	Yes
CONTROL MODES	H	1	Controlling Sensor	24	No	No	Yes	Yes
		2	BMS Tstat Input (Active/Inactive)	24	No	No	Yes	Yes
		3	BMS (Active/Inactive)	24	No	No	Yes	Yes
		4	ModBus (Active/Inactive)	25	No	No	Yes	Yes
		5	ModBus T/O (Timeout)	25	No	No	Yes	Yes
		6	Cascade Address	25	No	No	Yes	Yes
		7	Cascade Type (L/L / EFF)	25	No	No	Yes	Yes
		8	Max Cascade Outlet Set Point	25	No	No	Yes	Yes
		9	Cascade Offset	25	No	No	Yes	Yes
		10	Cascade Off/On Differential	25	No	No	Yes	Yes
		11	Min On/Off Time	25	No	No	Yes	Yes
		12	Min Next On Time	25	No	No	Yes	Yes
		13	Boiler Size	25	No	No	Yes	Yes
CIRCULATION PUMPS	I	1	System Pump Delay	26	No	No	Yes	Yes
		2	Boiler Pump Delay	26	No	No	Yes	Yes
		3	DHW Pump Delay	26	No	No	Yes	Yes
		4	Boiler Pump Anti-Seize Delay	26	No	No	Yes	Yes
		5	Boiler Pump Min Voltage	26	No	No	Yes	Yes
		6	System Pump Type (CFH/WWSD)	26	No	No	Yes	Yes
		7	DHW Pump Anti-Seize Delay	26	No	No	Yes	Yes
		8	System Pump Anti-Seize Delay	26	No	No	Yes	Yes

1 Service

Parameter table

Table 1-4 (continued from previous page) This table lists SMART SYSTEM control module parameters and where to access them

Menu	Sub Item	Description	See Page	User Access		Installer Access		
				Display	Modify	Display	Modify	
BMS	J	1	BMS Type (Power / Set Point)	26	No	No	Yes	Yes
		2	Volts at Min	26	No	No	Yes	Yes
		3	Volts at Max	26	No	No	Yes	Yes
		4	Rate at Min Volts	26	No	No	Yes	Yes
		5	Rate at Max Volts	26	No	No	Yes	Yes
		6	Set Point at Min Volts	27	No	No	Yes	Yes
		7	Set Point at Max Volts	27	No	No	Yes	Yes
		8	On Volts	27	No	No	Yes	Yes
		9	Off Differential Volts	27	No	No	Yes	Yes
SERVICE NOTIFICATION	K	1	Service Notification Months	27	No	No	Yes	Yes
		2	Service Notification Running Time	27	No	No	Yes	Yes
		3	Service Notification Cycles	27	No	No	Yes	Yes
		4	Reset Maintenance Reminder	27	No	No	Yes	Yes
		5	Installer Name and Phone Number	27	No	No	Yes	Yes

1 Service *(continued)*

Viewable and changeable control parameters

CAUTION

Before changing parameters, note the settings so that the unit can be returned to its original operating parameters.

A: General

Date and Time

The control uses an internal clock for the night setback feature and for logging of events. For these features to work correctly, the clock must be set when the boiler is first installed or anytime the boiler has been powered off for more than four (4) hours. To set the clock, parameter **A1** must be accessed.

NOTICE

The internal clock does not adjust for Daylight Savings Time and therefore, will require a manual adjustment.

Software Version

The software version allows the user to view the software version in use by the control. This software controls the operation of the boiler. When a new software version becomes available, the existing control can be replaced with a new control to update the software.

Software version is read only.

Temperature units (°C / °F)

The control can be configured to display temperature in either °C or °F. This parameter can be changed by the user or the installer by accessing parameter **A3**. The default is °F.

Space Heating (SH) and Domestic Hot Water (DHW) Night Setback Offset

The unit's internal clock can be set up to run at a lower set point temperature during unoccupied times. Both the space heating and DHW can be programmed for night setback. When in night setback, the control reduces the set point by a fixed amount. For space heating, it subtracts the space heating night setback offset from each of the SH user set points (parameters **B1**, **B6**, and **B9**), or the calculated outdoor reset set point (if lower). For DHW, it subtracts the DHW night setback offset from the tank set point (parameter **E2**). **NOTE:** The DHW night setback will not work without a tank sensor installed.

The installer may adjust the space heating night setback offset by accessing **A4** and the DHW night setback offset by accessing parameter **A7**. The minimum setting is 0°F (0°C) and the maximum setting is 90°F (50°C).

Space Heating (SH) and Domestic Hot Water (DHW) Night Setback On Times

This is the time in which the SH Night Setback Offset becomes active. There are 7 start times and 7 stop times each for the space heating and DHW night setback features. Both may be set to any time within a 7-day week. These settings are referred to as triggers. Multiple start or stop triggers may be set within a single day, if desired. When a start trigger and a stop trigger are set to the same time, the stop trigger has priority. The installer may adjust the space heating night setback start triggers by accessing parameter **A5**. The DHW start triggers in parameter **A8**. This screen shows the start trigger number, the day of the week, and the time of day.

NOTICE

Please note that the brackets ([]) denote screen status.

1. When the screen is first accessed, start trigger number 1 is shown. If a different trigger number is desired, the installer can rotate the NAVIGATION dial until the desired trigger number is displayed. Once the desired trigger number is selected, the installer can press the SCROLL knob and the day of the week will start to flash.
2. The installer can adjust the day of the week to the one he wishes to set. Once the day is set, the installer can press the NAVIGATION dial and the hour will begin to flash.
3. After setting the hour, the installer can press the SCROLL knob and the minutes will flash. Once all settings have been made, the installer can press the RIGHT SELECT [SAVE] key. The installer can now select a different trigger and adjust the settings for that trigger.
4. Once all adjustments are made, the installer can press the RIGHT SELECT [SAVE] key to save all of the new settings and return to the **A** menu, or press the LEFT SELECT [EXIT] key to return to the **A** menu without saving the changes.

Space Heating (SH) and Domestic Hot Water (DHW) Night Setback Off Times

The corresponding space heating night setback stop triggers are set by accessing parameter **A6**. The stop triggers for the DHW night setback feature can be adjusted by accessing parameter **A9**. The adjustment procedure for these parameters is identical to the space heating start triggers described above.

1 Service

Display Timeout

This is the time in which the display remains illuminated. The range is 10 seconds to 10 minutes. The default is 3 minutes.

B: Temperature Settings

Space Heating (SH1, SH2, SH3) Set Point

CAUTION

Mixing valves are required for the protection of any low temperature loops.

There are three (3) individual user set points for better zone control. These are listed as SH1 Set Point through SH3 Set Point. If multiple set points are calling for heat the highest set point has priority. The range is 32°F (0°C) to 190°F (88°C). The default is 125°F (52°C).

Space Heating (SH) Minimum Set Point

The SH minimum set point sets the minimum water temperature set point that can be used for space heating operation. The user or installer will not be able to program the control with a lower SH set point. This parameter can only be changed by the installer by accessing parameter **B2**. The temperature range of this parameter is 32°F (0°C) to 190°F (88°C). The default value is 70°F (21°C).

Space Heating (SH) Maximum Set Point

The SH maximum set point sets the maximum water temperature set point that can be used for space heating. The user or installer will not be able to program the control with a higher SH set point. This parameter can only be changed by the installer by accessing parameter **B3**. The temperature range of this parameter is 32°F (0°C) to 190°F (88°C). The default value is 185°F (85°C).

SH1 - SH3 Offset Set Point

The SH offset sets how many degrees above set point the temperature has to go before the boiler will shut off. This parameter can only be changed by the installer by accessing parameters **B4**, **B7** and **B10**. The temperature range of these parameters is 0°F to 20°F. The default value is 10°F.

SH1 - SH3 Differential Set Point

The SH differential sets how many degrees below the offset the temperature has to drop before the boiler turns back on. This parameter can only be changed by the installer by accessing parameters **B5**, **B8** and **B11**. The range is 0°F to 60°F. The default is 20°F.

3-Way Valve Time

Not used.

C: Data Logging

Reset last 10 errors

The reset last 10 errors function clears the last 10 errors log.

D: Functions

Service Mode Delay

By pressing the pin button on the front of the display for five (5) seconds, the control will be placed in Service Mode. This will override all other heat demands. The Service Mode allows the installer to set the unit to either maximum firing rate or minimum firing rate for the purpose of combustion analysis. The delay sets the length of time the boiler will stay in the Service Mode if no keys have been pressed before going back to its original state. This parameter can only be changed by the installer by accessing parameter **D1**. The time range of this parameter is 0 to 30 minutes. The default value is 20 minutes.

Freeze Protection Pump On

The SMART SYSTEM control will turn on the boiler and system pump outputs whenever the inlet temperature drops below this setting. This is done to prevent the water in the heat exchanger from freezing. Certain low-temperature applications (such as snow melt) can operate at temperatures around freezing, so this setting needs to be lowered in these cases. The installer can adjust the temperature at which the pump outputs are turned on by accessing parameter **D2**. The minimum setting is -4°F (-20°C), and the maximum setting is 45°F (7.2°C). The default setting is 45°F (7.2°C).

Freeze Protection Burner On

If running the pumps does not prevent the inlet temperature from falling closer to freezing, the SMART SYSTEM control will fire the burner at low fire. The installer can adjust the temperature at which the burner fires by adjusting parameter **D3**. The minimum setting is -4°F (-20°C), and the maximum setting is 45°F (7.2°C). The default setting is 37°F (2.8°C).

Freeze Protection Burner Differential

Once the burner has started firing due to a low inlet temperature, the inlet temperature must increase by this amount before the burner turns back off. The installer can adjust this differential by accessing parameter **D4**. The minimum setting is 0°F, and the maximum is 20°F. The default setting is 5°F (2.8°C).

1 Service *(continued)*

E: DHW Settings

DHW Boiler Set Point

When a DHW call for heat becomes active, the control will use the DHW boiler set point to determine the firing rate of the boiler based on the boiler outlet water temperature.

This parameter can be changed by the installer by accessing parameter **E1**. The temperature range of this parameter is 60°F (16°C) to 190°F (88°C). The default value is 180°F (82°C).

DHW Tank Set Point

By installing a tank sensor, the SMART SYSTEM control can perform the tank thermostat function. The SMART SYSTEM control automatically detects the presence of this sensor, and generates a DHW call for heat when the tank temperature drops below the tank set point differential (parameter **E3**), and finishes the call for heat when the tank temperature reaches tank set point. This parameter can be changed by the installer by accessing parameter **E2**. The temperature range of this parameter is 68°F (20°C) to 190°F (88°C). The default value is 125°F (52°C).

Tank Set Point Differential

When a tank sensor is installed, the tank temperature must drop this amount below the tank set point (parameter **E2**) before the heater will turn on. The installer can adjust this setting by accessing parameter **E3**. The minimum setting is 0° (0°C), and the maximum is 40°F (22°C). The default setting is 6°F (3°C).

Boiler Set Point Offset

This parameter reflects the degrees above DHW boiler set point the temperature has to go before the boiler will shut off. The range is 0°F (0°C) to 20°F (13°C). The default setting is 10°F (6°C).

Boiler Set Point Differential

This parameter reflects the degrees below DHW boiler offset the temperature has to go before the boiler shuts off. The range is 0°F (0°C) to 60°F (33°C). The default setting is 20°F (13°C).

SH/DHW Switching Time

When a boiler has a space heating demand and it receives a DHW demand, it will immediately switch to the DHW demand and start a timer. Once the timer has expired, the boiler will switch back to the space heating demand and start another timer. Once this timer expires, it will switch back to the DHW demand. The installer can adjust the length of time the boiler will service the space heating demand by accessing parameter **E6**. The minimum setting is 0 minutes and the maximum setting is 200 minutes. The default time is 30 minutes.

DHW/SH Switching Time

When a boiler has a DHW demand and it receives a space heating demand, the SMART SYSTEM control will start a timer. Once the timer expires, it will stop the DHW demand and service the space heating demand. The installer can adjust the length of time the boiler will service the DHW demand by accessing parameter **E7**. The minimum setting is 0 minutes and the maximum setting is 200 minutes. The default setting is 30 minutes.

Tank Minimum Set Point

This setting controls the minimum user set point for the tank temperature. The installer can adjust this by accessing parameter **E8**. The minimum setting is 60°F (16°C) and the maximum setting is the maximum tank set point (parameter **E9**).

Tank Maximum Set Point

This setting controls the maximum user set point for the tank temperature. The installer can adjust this by accessing parameter **E9**. The minimum setting is the minimum tank set point (parameter **E8**) and the maximum setting is 185°F (85°C).

DHW Type

This parameter determines whether the Knight XL treats the indirect DHW tank as a separate load, or as a zone on the primary loop. When programmed as a separate load, the boiler will turn on the DHW pump and then turn off the boiler pump when an indirect DHW demand begins. When programmed as a zone, the boiler will turn on the DHW pump, leave the boiler pump on and raise the system set point to the DHW boiler set point (parameter **E1**), if it is higher than the current SH set point.

This setting may be changed by the installer by accessing parameter **E10**. The choices are NORMAL and ZONE. The default setting is NORMAL.

Fan Speed Limiting for Indirect DHW Tank

This parameter determines the maximum fan speed (and therefore the maximum rate) to be used when heating an indirect DHW tank. This setting may be used when the tank is unable to accept all of the BTU's available from the boiler. This parameter may be adjusted by the installer by accessing parameter **E11**. The default value is the maximum fan speed for that model.

1 Service

F: Outdoor Reset

The option of controlling up to three (3) different outdoor resets for low outdoor temperatures is available.

Low Outdoor Temperature

When the outdoor air temperature drops below this point, the water temperature will be at parameters **F3**, **F8** and **F13** (FIG. 1-1). However, if the user set point is set lower, the water temperature will be limited by the user set point instead. This parameter can be changed by the installer by accessing parameter **F1**. The temperature range of this parameter is -40°F (-40°C) to 104°F (40°C). The default value is 25°F (-4°C).

High Outdoor Temperature

When the outdoor air temperature rises to or above this point, the water temperature will be at parameters **F4**, **F9** and **F14** (FIG. 1-1). This parameter can be changed by the installer by accessing parameter **F2**. The temperature range of this parameter is -40°F (-40°C) to 104°F (40°C). The default value is 70°F (21°C).

SH1 - SH3 Set Point at Low Outdoor Temperature

When the outdoor air temperature drops below this point, the water temperature will be at this setting (FIG. 1-1). However, if the user set point is set lower, the water temperature will be limited by the user set point instead. These parameters can be changed by the installer by accessing parameters **F3**, **F8** and **F13**. The temperature range of this parameter is -40°F (-40°C) to 104°F (40°C). The default value is 25°C (-4°C).

SH1 - SH3 Set Point at High Outdoor Temperature

When the outdoor air temperature rises to or above this point, the water temperature will be at this setting (FIG. 1-1). These parameters can be changed by the installer by accessing **F4**, **F9** and **F14**. The temperature range of this parameter is -40°F (-40°C) to 104°F (40°C). The default value is 70°F (21°C).

Outdoor Air Shutdown (SH1 - SH3)

When the outdoor temperature rises above this point, the control will block all SH demands (DHW demands will still be active). These parameters can be changed by the installer by accessing parameters **F5**, **F10** and **F15**. The temperature range of this parameter is 32°F (0°C) to 104°F (40°C). The default value is 70°F (21°C).

Figure 1-1 Outdoor Air Reset Curve

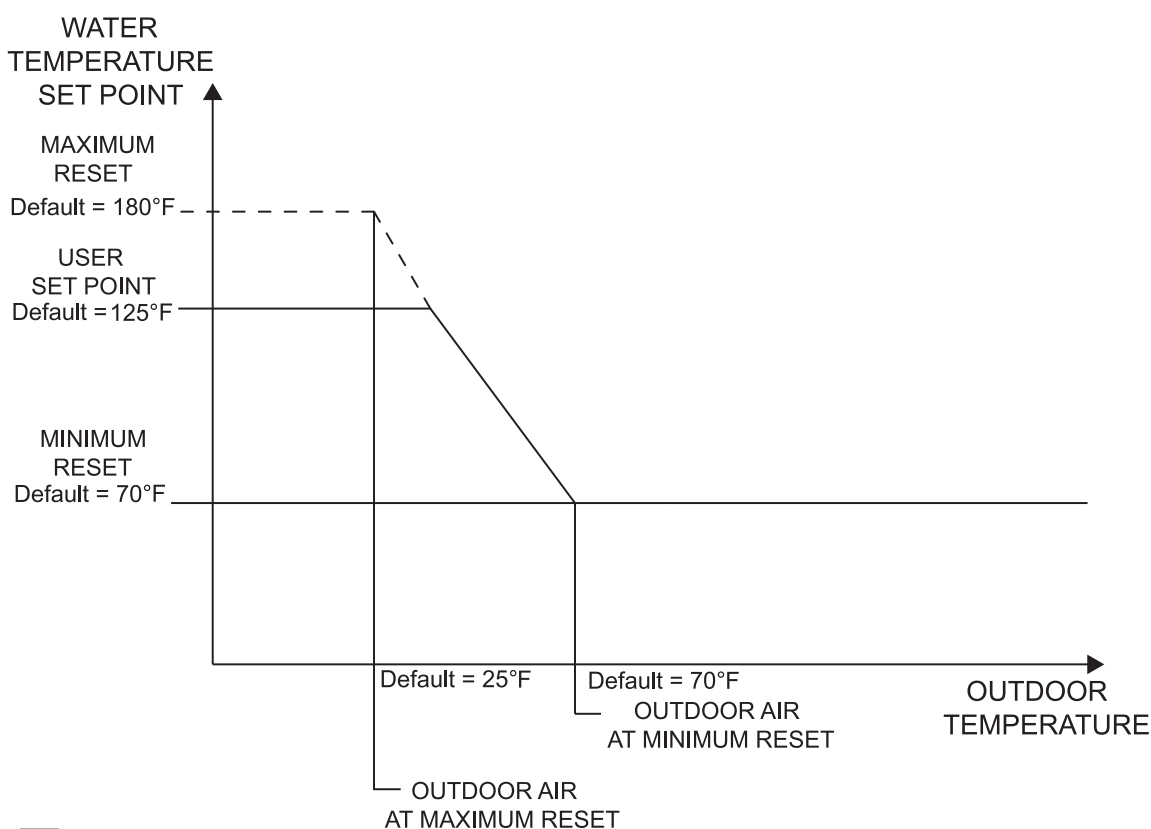

1 Service *(continued)*

Outdoor Air Shutdown Differential (SH1 - SH3)

The outdoor air shutdown differential parameter is the number of degrees below parameters **F5**, **F10** and **F15** the outdoor air temperature must go before the boiler will respond to a SH demand. These parameters can be changed by the installer by accessing parameters **F6**, **F11** and **F16**. The temperature range of this parameter is 0°F (0°C) to 90°F (50°C). The default value is 10°F (6°C).

Shift Reset Curve (SH1 - SH3)

There is a shift reset curve for each outdoor reset. The shift reset curve parameter shifts the actual set point above the calculated set point the number of degrees in this parameter. These parameters can be changed by the installer by accessing parameter **F7**, **F12** and **F17**. The temperature range of this parameter is -17°F (-27°C) to 18°F (-8°C). The default value is 0°F (0°C). This feature will be active if this parameter is set to anything other than 0°F (0°C).

Boost Temperature

If a SH demand lasts longer than the programmed time delay setting (**F19**) and there have been no DHW demands, the control will increase the water temperature set point by the amount in this parameter. If the SH demand continues through another time period, the set point will be increased again. This will continue until either the SH demand ends, a maximum of 20 increases has occurred, or the maximum set point has been reached. Once the SH demand has been satisfied the set point will revert back to its calculated setting. The boost temperature can be changed by the installer by accessing parameter **F18**. The temperature range of this parameter is 0°F (0°C) to 25°F (-4°C). The default value is 0°F (0°C). This feature will be active if this parameter is set to anything other than 0°F (0°C).

Boost Time

The boost time parameter sets the amount of time that must elapse with a SH demand before the water temperature set point will be increased. This parameter can be changed by the installer by accessing parameter **F19**. The time range for this parameter is 0 minute to 50 minutes. The default value is 0 minutes.

G: Anti-Cycling

Anti-Cycling Time

Once a SH demand has been satisfied, a set amount of time must elapse before the control will respond to a new SH demand. The control will block the new heat demand and anti-cycling will be shown in the display until the time has elapsed or the water temperature drops below parameter **G2**. This parameter can be changed by the installer by accessing parameter **G1**. The time range for this parameter is 0 minutes to 10 minutes. The default value is 1 minute.

Anti-Cycling Override Differential

The control will bypass the anti-cycling time if the water temperature drops too quickly. The control will use the water temperature the boiler was at when it shut off as the starting point. If the temperature drops below the temperature parameter the control will abort anti-cycling and allow the boiler to fire. This parameter can be changed by the installer by accessing parameter **G2**. The temperature range of this parameter is 0°F (0°C) to 54°F (30°C). The default value is 10°F (6°C).

Ramp Delay (Enable / Disable)

This parameter allows the installer to enable or disable the SH ramp delay by accessing parameter **G4**.

1 Service

SH Ramp Delay

NOTICE

Please note that the brackets ([]) denote screen status.

The SMART SYSTEM control can be programmed to limit the firing rate for a fixed period of time at the start of a space heating demand. There are six (6) possible limits, each with their own time delay. The first limit applies as soon as the burner starts. Once its time delay expires, the second limit is applied and its timer begins. The control steps through these limits until the 6th (sixth) limit expires. Note, however, that the rate can be held to less than 100% if so desired. The installer can adjust the firing limits and time delays by accessing parameter **G4**. Once this parameter is selected, the screen will show the step number, the time delay for that step and the limit value corresponding with that step. If the installer wishes to adjust one of the values in that step, he can press the NAVIGATION dial until the value he wishes to change is flashing. The installer can then rotate the NAVIGATION dial to adjust that value. If the installer presses the RIGHT SELECT [SAVE] key while the limit value is flashing, the step value will flash again. The installer can then select the next step and adjust the delay and limit values corresponding with that step.

When finished, the installer can press the RIGHT SELECT [SAVE] key to store the new settings, or the LEFT SELECT [EXIT] key to return to the **G** parameter list without saving the changes. The delay value can be set between 0 minutes and 120 minutes. The limit value can be set between 0% and 100%.

H: Control modes

Controlling Sensor

The SH controlling sensor parameter selects the sensor the control will use to regulate the boiler firing rate. This parameter is adjustable by the installer by accessing parameter **H1**. The sensor selections are as follows: The outlet sensor regulates the firing rate based on the outlet water temperature of the boiler and the inlet sensor regulates the firing rate based on the inlet water temperature of the boiler. If the outlet sensor is selected, and the optional system supply sensor is connected, the control will regulate the firing rate based on the system supply sensor temperature. The default sensor is the Outlet Sensor.

BMS Thermostat Input (Active / Inactive)

When controlling the boiler through the 0 - 10V BMS input or through ModBus, the boiler can be enabled one of two ways. With parameter **H2** set to ACTIVE, the boiler will be enabled by closing the Room Thermostat 1 input. With parameter **H2** set to INACTIVE, the boiler will be enabled by the voltage level on the 0 - 10V input (in the case of 0 - 10V BMS control), or the 0 - 10V input value received through ModBus. The default value is INACTIVE.

BMS (Active / Inactive)

The set point or modulation of the boiler may be controlled through the 0 - 10V BMS input or through Modbus. When parameter **H3** is set to INACTIVE, the 0 - 10V input will be ignored. When set to ACTIVE, the set point or modulation will be controlled by the voltage on the 0 - 10V input (in the case of 0 - 10V BMS control), or the 0 - 10V input value received through ModBus. The default value is INACTIVE.

Figure 1-2 Ramp Delay Interval

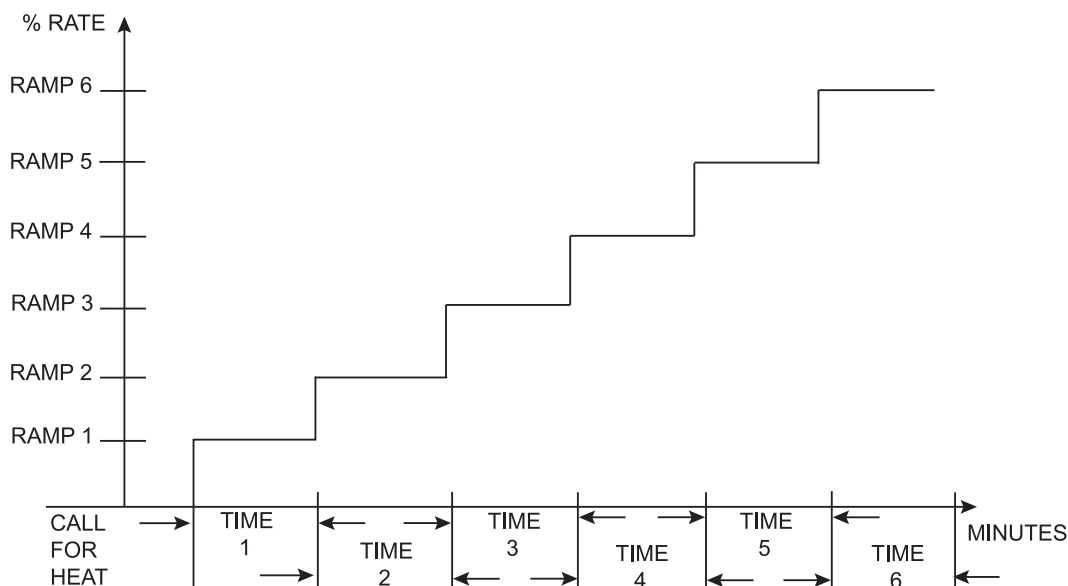

1 Service *(continued)*

Modbus (Active / Inactive)

When BMS is set to ACTIVE (see BMS Active / Inactive) and the boiler is being controlled through Modbus, set parameter **H4** to ACTIVE. Otherwise, set the Modbus parameter to INACTIVE. Note that the boiler can still be monitored by ModBus with this parameter set to INACTIVE. The default value is INACTIVE.

Modbus T/O (Timeout)

The amount of time the unit controls will wait to receive a communication string from the BMS controller before reverting back to its own internal parameters. This parameter is adjustable by the installer by accessing parameter **H5**. The default value is 10 seconds.

Cascade Address

The boiler designated as the Leader needs to be programmed with address 0. All the Member boilers require addresses from 1 to 7, and the addresses must be different for each Member. The addresses can be in any order, regardless of the order in which the units are wired together. This parameter is adjustable by the installer by accessing parameter **H6**. The outdoor air (if used) and system supply sensor must be connected to the Leader boiler. The default address is 1.

If installing the boilers in an existing system, the new boilers should be programmed as the Leader and/or the higher number addresses.

Cascade Type (L/L / EFF)

There are two (2) options for the way a Cascade divides the load between its heaters. The first is Lead/Lag, designated at L/L in the menu. This method is used when it is desired to have the least amount of total flow through the boilers. This method works much like the current Cascade, except it will modulate the last two (2) boilers, instead of just the last boiler. This change provides for smoother transitions when a boiler turns on or off. When the last boiler reaches 100% and the calculated load is still increasing, it will start the next boiler at 20% and reduce the previous boiler to 80%, thus eliminating the sudden jump in total output of the Cascade. Therefore, the dead-zone we had in the original Cascade is no longer necessary. When the calculated load is decreasing and the last boiler gets down to 20% fire, it will hold it there and start lowering the firing rate on the next-to-last boiler. When the next-to-last boiler reaches 35%, it will turn the last boiler off and raise the rate of the next-to-last boiler to 55%, thus eliminating the sudden drop in total output of the Cascade.

The other Cascade divider method is Efficiency Optimization, designated as EFF in the menu. This method is used, as the name implies, when it is desired to have the most efficient system. When the first boiler reaches a certain rate (default = 90%), it lowers its rate to 45% and turns on the next boiler at 45%. The two (2) boilers then modulate at the same rate.

As the calculated load increases further and both boilers ramp up to 90%, it lowers the rate of the first two (2) boilers to 60% and brings the next boiler on at 60%. The three (3) boilers then modulate together. As the calculated load decreases, the boilers will reach a lower threshold (default = 35%), at which time the last boiler (the third in our example) will turn off and the Cascade will increase the rates of the remaining boilers to provide the equivalent total output as before ($(3 \times 35\%) / 2 = 52.5\%$ in our example).

Maximum Cascade Outlet Set Point

This parameter determines the set point used by the individual boilers in a Cascade. When a boiler is commanded to fire by the Leader boiler, it will attempt to achieve this temperature at its outlet. The Leader boiler will limit the modulation of the last boiler to fire in order to hold the temperature at the system supply sensor to the user set point. If any of the boiler outlet temperatures reach the maximum cascade set point, the boiler will then modulate down on its own in order to keep its outlet temperature within the maximum cascade set point. Therefore, this parameter can be used to limit the outlet temperatures of all the boilers in a Cascade. Note that this parameter does not apply when the boiler is heating an indirect DHW tank. This parameter is adjustable by the installer by accessing parameter **H8**. The default maximum cascade set point is 185°F (85°C).

Cascade Offset

This parameter determines how much the temperature must go above set point before the lead boiler will turn off. This parameter can be adjusted by the installer by accessing parameter **H9**. The default value is 10°F (6°C).

Cascade Off-On Differential

This parameter determines how much the temperature must go below the turn off temperature (Set point + Offset) before the lead boiler turns on. This parameter can be adjusted by the installer by accessing parameter **H10**. The default value is 20°F (11°C).

Minimum On/Off Time

In order to prevent units in a Cascade from short cycling, this parameter defines the minimum ON and OFF time for each unit. The installer can adjust this time by accessing parameter **H11**. The minimum setting is 0 seconds and the maximum setting is 10 minutes. The default is 30 seconds.

Minimum Next On Time

In order to reduce the risk of temperature overshoot with a Cascade, this parameter defines the minimum time delay from starting one unit until the next unit may be started. The installer can adjust this time delay by accessing parameter **H12**. The minimum setting is 0 minutes and the maximum setting is 10 minutes. The default is 60 seconds.

Boiler Size

Not used.

1 Service

I: Circulation pumps

System Pump Delay

The system pump delay parameter sets the length of time the system pump (if connected) will run after a SH demand has been satisfied. Setting the delay time to 0 will disable the pump. This parameter is adjustable by the installer by accessing parameter **I1**. The time range for this parameter is 0 minutes to 40 minutes. The default time is 30 seconds.

Boiler Pump Delay

The SH pump delay parameter sets the length of time the boiler pump will run after a SH demand has been satisfied. Setting the delay time to 0 will disable the pump. This parameter is adjustable by the installer by accessing parameter **I2**. The time range for this parameter is 0 minutes to 40 minutes. The default time is 30 seconds.

DHW Pump Delay

The DHW pump delay parameter sets the length of time the DHW pump (if connected) will run after a DHW demand has been satisfied. Setting the delay time to 0 will disable the pump. This parameter is adjustable by the installer by accessing parameter **I3**. The time range for this parameter is 0 minutes to 40 minutes. The default time is 30 seconds.

Boiler Pump Anti-Seize Delay

If the boiler pump does not run for 24 hours, it will be turned on briefly to prevent it from seizing. The length of time it runs is determined by parameter **I4**. The range of this setting is 0 seconds to 40 minutes. The default setting is 20 seconds.

Boiler Pump Minimum Voltage

The speed of the boiler pump can be controlled by the SMART SYSTEM control in order to maintain a minimum ΔT through the heat exchanger. Thus, as the firing rate decreases, the speed of the boiler pump can decrease as well. The SMART SYSTEM control outputs a 0 - 10V signal to the boiler pump to control its speed. Parameter **I5** determines the minimum voltage given to the boiler pump, thereby setting its minimum speed. The range of this setting is 2.5V to 10V. The default setting is 3.5V.

System Pump Type (CFH / WWSD) CFH = Call for Heat, WWSD = Warm Weather Shutdown

The system pump can be programmed to operate in response to any of the Room Thermostat inputs, or to run continuously until the boiler goes into Outdoor Shutdown. To program the system pump to operate only with a space heating call for heat, set parameter **I6** to CFH. To program the system pump to run continuously until outdoor shutdown starts, set parameter **I6** to WWSD. The default setting is CFH.

DHW Pump Anti-Seize Delay

If the boiler pump does not run for 24 hours, it will be turned on briefly to prevent it from seizing. The length of time it runs is determined by parameter **I4**. The range of this setting is 0 seconds to 40 minutes. The default setting is 20 seconds.

System Pump Anti-Seize Delay

If the boiler pump does not run for 24 hours, it will be turned on briefly to prevent it from seizing. The length of time it runs is determined by parameter **I4**. The range of this setting is 0 seconds to 40 minutes. The default setting is 20 seconds.

J: BMS

BMS Type (Power / Set Point)

When programmed for BMS control through the 0 - 10V BMS input or through ModBus, the 0 - 10V signal can be interpreted as either a modulation command or a set point. When parameter **J1** is set to POWER, the 0 - 10V signal will control the modulation. When set to SETPOINT, the 0 - 10V signal will control the SH set point. The default setting is POWER.

Volts at Minimum

When programmed for BMS control through the 0 - 10V BMS input or through ModBus, parameter **J2** should be set to the minimum voltage signal sent to the SMART SYSTEM control. The range of this parameter is 0.0V to the Volts at Minimum value (parameter **J3**). The default setting is 2.0V.

Volts at Maximum

When programmed for BMS control through the 0 - 10V BMS input or through ModBus, parameter **J3** should be set to the maximum voltage signal sent to the SMART SYSTEM control. The range of this parameter is the Minimum value (parameter **J2**) to 10.0V. The default value is 10.0V.

Rate at Minimum Volts

When programmed for BMS control through the 0 - 10V BMS input or through ModBus and the BMS Type is programmed as POWER, the modulation percentage represented by the Volts at Minimum parameter (**J2**) is set by parameter **J4**. The minimum value is 0% and the maximum is the Power at Maximum Volts setting **J5**. The default value is 20%.

Rate at Maximum Volts

When programmed for BMS control through the 0 - 10V BMS input or through ModBus and the BMS Type is programmed as POWER, the modulation percentage represented by the Volts at Maximum parameter (**J3**) is set by parameter **J5**. The minimum value is the Power at Minimum Volts setting **J4** and the maximum is 100%. The default value is 100%.

1 Service *(continued)*

Set Point at Minimum Volts

When programmed for BMS control through the 0 - 10V BMS input or through ModBus and the BMS Type is programmed as SETPOINT, the set point represented by the Volts at Minimum parameter (J2) is set by parameter J6. The minimum value is 32°F (0°C) and the maximum is the Set Point at Maximum Volts setting J7. The default value is 70°F (21°C).

Set Point at Maximum Volts

When programmed for BMS control through the 0 - 10V BMS input or through ModBus and the BMS Type is programmed as SETPOINT, the set point represented by the Volts at Maximum parameter (J4) is set by parameter J7. The minimum value is the Set Point at Minimum Volts setting J6 and the maximum is 190°F (88°C). The default value is 180°F (82°C).

On Volts

When programmed for BMS control through the 0 - 10V BMS input or through ModBus and the BMS Thermostat Input is set to INACTIVE, parameter J8 determines the 0 - 10V BMS input voltage at which the boiler is enabled. The minimum value is 0.5V and the maximum is 10.0V. The default value is 2.0V.

Off Differential Volts

When programmed for BMS control through the 0 - 10V BMS input or through ModBus and the BMS Thermostat Input is set to INACTIVE, parameter J9 determines how far below the On Volts setting J8 the 0 - 10V BMS input voltage must be in order to disable the boiler. The minimum value is 0.2V and the maximum is the On Volts setting J8. The default value is 1.0V.

K: Service Notification

Service Notification in Months

When the boiler control determines that a scheduled service is due based on days of installation, the boiler display will alternate the standard boiler display text with the message SERVICE DUE every 5 seconds. This parameter is adjustable by the installer by accessing parameter K1. The time range for this parameter is 0 months to 36 months. The default time is 0 months.

This feature has been disabled by the manufacturer. To enable this feature change parameter K1 to the desired time range.

Service Notification Running Time

When the boiler control determines that a scheduled service is due based on the hours of actual operation, the boiler display will turn yellow and a new status screen will appear informing the installer that maintenance is required. This parameter is adjustable by the installer by accessing parameter K2. The time range for this parameter is 0 hours to 100,000 hours. The default time is 8,760 hours.

Service Notification Cycles

When the boiler control determines that a scheduled service is due based on the number of boiler cycles, the boiler display will alternate the standard boiler display text with the message SERVICE DUE every 5 seconds. This parameter is adjustable by the installer by accessing parameter K3. The range for this parameter is 0 cycles to 100,000 cycles. The default is 50,000 cycles.

Reset Maintenance Reminder

Once servicing has been completed, the service notification counter should be reset. This parameter can be reset by the installer by accessing parameter K4. Once accessed, press the RESET key to reset the service notification counter.

Installer Name and Phone Number

NOTICE

Please note that the brackets ([]) denote screen status.

When a Maintenance Reminder timer or counter has expired, a Maintenance Reminder screen will appear on the display. By programming the installer's name and phone number, this information will appear on the Maintenance Reminder Screen at that time. This can be programmed by accessing parameter K5. When selected, another menu will appear with PHONE and NAME.

1. Rotate the NAVIGATION dial to point to the name/phone number to program and press the NAVIGATION dial. The screen will now display the selected item (either PHONE or NAME).
2. Press the NAVIGATION dial again. A cursor will appear at the bottom of the screen. By rotating the NAVIGATION dial, various numbers and characters will appear. When the desired number/character is found, press the NAVIGATION dial. The cursor will move to the next position.
3. Repeat this procedure until the entire message is entered. If you make a mistake and wish to back up one character, select the back arrow (←) character and press the NAVIGATION dial.
4. When finished, press the RIGHT SELECT [SAVE] key to return to the previous menu.

2 Maintenance

Maintenance and annual startup

Table 2-1 Service and Maintenance Schedules

Service technician (see the following pages for instructions)		Owner maintenance (see the Knight XL User's Information Manual for instructions)	
ANNUAL START-UP	General:		
	<ul style="list-style-type: none"> • Address reported problems • Inspect interior; clean and vacuum if necessary; • Clean condensate trap and fill with fresh water • Check for leaks (water, gas, flue, condensate) • Verify flue and air lines in good condition and sealed tight • Check system water pressure/system piping/expansion tank • Check control settings • Check ignition and flame sense electrodes (sand off any deposits; clean and reposition) • Check wiring and connections • Perform start-up checkout and performance verification per Section 10 in the Knight XL Installation and Operation Manual. • Flame inspection (stable, uniform) • Flame signal (at least 10 microamps at high fire) • Clean the heat exchanger if flue temperature is more than 54°F (30°C) above return water temperature. 	Daily	<ul style="list-style-type: none"> • Check boiler area • Check pressure/temperature gauge
	<p>If combustion or performance indicate need:</p> <ul style="list-style-type: none"> • Clean heat exchanger • Remove and clean burner using compressed air only • Clean the blower wheel 	Monthly	<ul style="list-style-type: none"> • Check vent piping • Check air piping • Check air and vent termination screens • Check relief valve • Check condensate drain system • Check air vents
		Periodically	<ul style="list-style-type: none"> • Test low water cutoff (if used) • Reset button (low water cutoff)
		Every 6 months	<ul style="list-style-type: none"> • Check boiler piping (gas and water) for leaks • Operate relief valve
	End of season months	<ul style="list-style-type: none"> • Shut boiler down (unless boiler used for domestic hot water) 	

2 Maintenance *(continued)*

⚠ WARNING Follow the Service and maintenance procedures given throughout this manual and in component literature shipped with the boiler. Failure to perform the service and maintenance could result in damage to the boiler or system. Failure to follow the directions in this manual and component literature could result in severe personal injury, death, or substantial property damage.

⚠ WARNING The boiler should be inspected annually only by a qualified service technician. In addition, the maintenance and care of the boiler designated in Table 2-1 and explained on the following pages must be performed to assure maximum boiler efficiency and reliability. Failure to service and maintain the boiler and system could result in equipment failure.

⚠ WARNING Electrical shock hazard – Turn off power to the boiler before any service operation on the boiler except as noted otherwise in this instruction manual. Failure to turn off electrical power could result in electrical shock, causing severe personal injury or death.

Address reported problems

1. Inspect any problems reported by the owner and correct before proceeding.

Inspect boiler area

1. Verify that boiler area is free of any combustible materials, gasoline and other flammable vapors and liquids.
2. Verify that air intake area is free of any of the contaminants listed in Section 1 of the Knight XL Installation and Operation Manual. If any of these are present in the boiler intake air vicinity, they must be removed. If they cannot be removed, reinstall the air and vent lines per this manual and the Knight XL Installation and Operation Manual.

Inspect boiler interior

1. Remove the front access cover and inspect the interior of the boiler.
2. Vacuum any sediment from inside the boiler and components. Remove any obstructions.

Clean condensate trap

1. Inspect the condensate drain line, condensate PVC fittings, and condensate trap.
2. Remove the PVC cap retaining screw from the PVC cap (FIG. 2-1).
3. Remove the 2 inch PVC cap with the switch located at the top of the trap (FIG. 2-1).
4. Remove any sediment in the trap.
5. Fill with fresh water until the water begins to pour out of the drain.
6. Replace the cap. Press the cap onto the trap until the cap makes contact with the drain.
7. Replace the retaining screw.

Figure 2-1 Condensate Trap

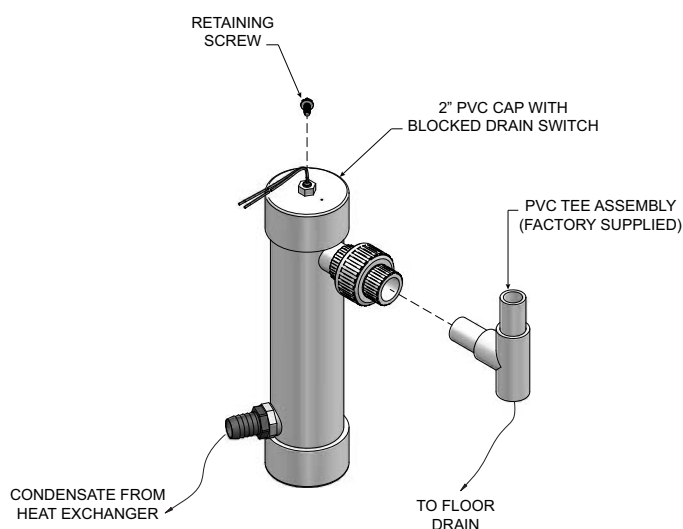

⚠ WARNING The condensate trap must be filled with water during all times of boiler operation to avoid flue gas emission from the condensate drain line. Failure to fill the trap could result in severe personal injury or death.

Check all piping for leaks

⚠ WARNING Eliminate all system or boiler leaks. Continual fresh makeup water will reduce boiler life. Minerals can build up in sections, reducing heat transfer, overheating heat exchanger, and causing heat exchanger failure. Leaking water may also cause severe property damage.

1. Inspect all water and gas piping and verify to be leak free.
2. Look for signs of leaking lines and correct any problems found.
3. Check gas line using the procedure found in Section 7 - Gas Connections of the Knight XL Installation and Operation Manual.

2 Maintenance

Flue vent system and air piping

1. Visually inspect the entire flue gas venting system and air piping for blockage, deterioration or leakage. Repair any joints that show signs of leakage. Verify that air inlet pipe is connected and properly sealed.
2. Verify that boiler vent discharge and air intake are clean and free of obstructions.

⚠ WARNING Failure to inspect for the above conditions and have them repaired can result in severe personal injury or death.

Check water system

1. Verify all system components are correctly installed and operational.
2. Check the cold fill pressure for the system. Verify it is correct (must be a minimum of 12 psi (82.7 kPa)).
3. Watch the system pressure as the boiler heats up (during testing) to ensure pressure does not rise too high. Excessive pressure rise indicates expansion tank sizing or performance problem.
4. Inspect automatic air vents and air separators. Remove air vent caps and briefly press push valve to flush vent. Replace caps. Make sure vents do not leak. Replace any leaking vents.

Check expansion tank

1. Expansion tanks provide space for water to move in and out as the heating system water expands due to temperature increase or contracts as the water cools. Tanks may be open, closed or diaphragm or bladder type. See Section 6 - Hydronic Piping of the Knight XL Installation and Operation Manual for suggested best location of expansion tanks and air eliminators.

Check boiler relief valve

1. Inspect the relief valve and lift the lever to verify flow. Before operating any relief valve, ensure that it is piped with its discharge in a safe area to avoid severe scald potential. Read Section 6 - Hydronic Piping of the Knight XL Installation and Operation Manual before proceeding further.

⚠ WARNING

Safety relief valves should be re-inspected AT LEAST ONCE EVERY THREE YEARS, by a licensed plumbing contractor or authorized inspection agency, to ensure that the product has not been affected by corrosive water conditions and to ensure that the valve and discharge line have not been altered or tampered with illegally. Certain naturally occurring conditions may corrode the valve or its components over time, rendering the valve inoperative. Such conditions are not detectable unless the valve and its components are physically removed and inspected. This inspection must only be conducted by a plumbing contractor or authorized inspection agency – not by the owner. Failure to re-inspect the boiler relief valve as directed could result in unsafe pressure buildup, which can result in severe personal injury, death, or substantial property damage.

⚠ WARNING

Following installation, the valve lever must be operated AT LEAST ONCE A YEAR to ensure that waterways are clear. Certain naturally occurring mineral deposits may adhere to the valve, rendering it inoperative. When manually operating the lever, water will discharge and precautions must be taken to avoid contact with hot water and to avoid water damage. Before operating lever, check to see that a discharge line is connected to this valve directing the flow of hot water from the valve to a proper place of disposal. Otherwise severe personal injury may result. If no water flows, valve is inoperative. Shut down the boiler until a new relief valve has been installed.

2. After following the above warning directions, if the relief valve weeps or will not seat properly, replace the relief valve. Ensure that the reason for relief valve weeping is the valve and not over-pressurization of the system due to expansion tank waterlogging or undersizing.

2 Maintenance *(continued)*

Inspect ignition and flame sense electrodes

1. Remove the ignition and flame sense electrodes from the boiler heat exchanger access cover.
2. Remove any deposits accumulated on the ignition/flame sense electrode using sandpaper. If the electrodes cannot be cleaned satisfactorily, replace with new ones.
3. Replace ignition/flame sense electrode, making sure gasket is in good condition and correctly positioned.

Check ignition ground wiring

1. Inspect boiler ground wire from the heat exchanger access cover to ground terminal strip.
2. Verify all wiring is in good condition and securely attached.
3. Check ground continuity of wiring using continuity meter.
4. Replace ground wires if ground continuity is not satisfactory.

Check all boiler wiring

1. Inspect all boiler wiring, making sure wires are in good condition and securely attached.

Check control settings

1. Set the SMART SYSTEM control module display to Parameter Mode and check all settings. See Section 1 of this manual. Adjust settings if necessary. See Section 1 of this manual for adjustment procedures.
2. Check settings of external limit controls (if any) and adjust if necessary.

Perform start-up and checks

1. Start boiler and perform checks and tests specified in Section 10 - Start-up of the Knight XL Installation and Operation Manual.
2. Verify cold fill pressure is correct and that operating pressure does not go too high.

Check burner flame

1. Inspect flame through observation window.
2. If the flame is unsatisfactory at either high fire or low fire, turn off boiler and allow boiler to cool down. Remove the burner and clean it thoroughly using a vacuum cleaner or compressed air. Do not use compressed air to clean burner if performed inside a building.
3. Remove the burner, reference FIG.'s 2-2 thru 2-4.
4. When replacing the burner, ensure gasket is in good condition and positioned correctly (FIG.'s 2-2 thru 2-4).

Figure 2-2 Burner Assembly - Model 400

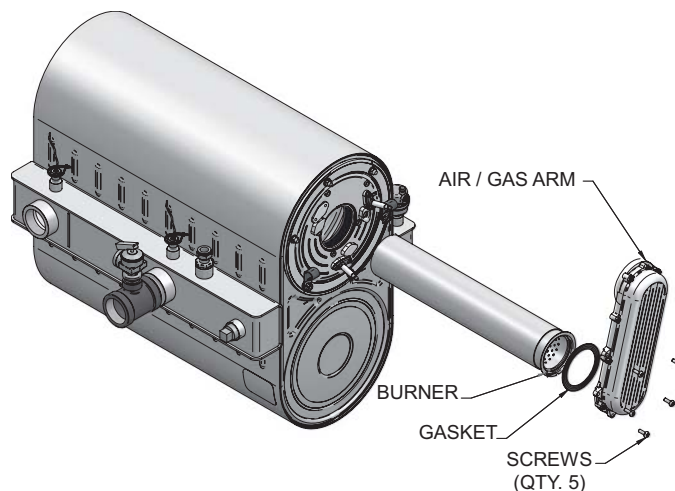

Figure 2-3 Burner Assembly - Model 501

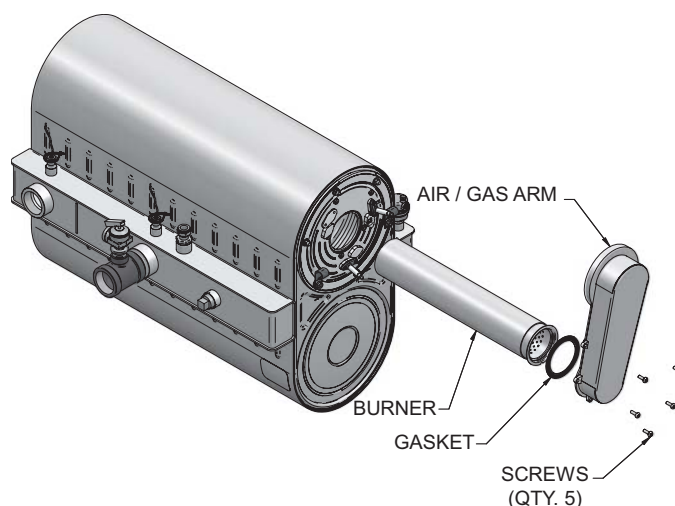
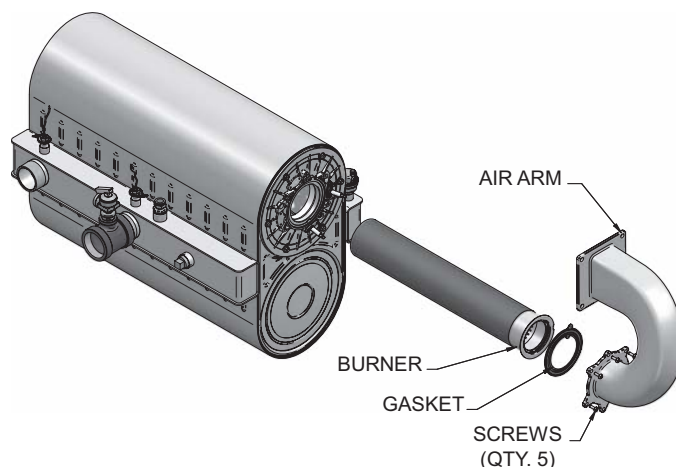

Figure 2-4 Burner Assembly - Models 601 - 801



2 Maintenance

Check flame signal

1. At high fire the flame signal shown on the display should be at least 10 microamps.
2. A lower flame signal may indicate a fouled or damaged flame sense electrode. If cleaning the flame sense electrode does not improve, ground wiring is in good condition, and ground continuity is satisfactory, replace the flame sense electrode.
3. See Section 3 - Troubleshooting in this manual for other procedures to deal with low flame signal.

Review with owner

1. Review the Knight XL User's Information Manual with the owner.
2. Emphasize the need to perform the maintenance schedule specified in the Knight XL User's Information Manual (and in this manual as well).
3. Remind the owner of the need to call a licensed contractor should the boiler or system exhibit any unusual behavior.
4. Remind the owner to follow the proper shutdown procedure and to schedule an annual start-up at the beginning of the next heating season.

Cleaning boiler heat exchanger

For recommended materials; including brush, appropriate extension(s), refractory cover, and detailed instructions see Table 2-2 - Heat Exchanger Cleaning Kits.

1. Shut down boiler:
 - Follow the "To Turn Off Gas to Appliance" instructions for the boiler in Section 10 - Startup of the Installation and Operation Manual.
 - Do not drain the boiler unless it will be exposed to freezing temperatures. If using freeze prevention fluid in system, do not drain.
2. Allow time for the boiler to cool to room temperature if it has been firing.
3. Remove the nuts securing the heat exchanger access cover to the heat exchanger and set aside.
4. Remove the heat exchanger access cover, burner, and gas/air arm assembly.

⚠ WARNING

The boiler contains ceramic fiber materials. Use care when handling these materials per instructions on page 3 of this manual. Failure to comply could result in severe personal injury.

5. Remove the condensate hose from the heat exchanger end. Connect a field supplied 3/4" diameter hose to a drain pan. Using field supplied means, cover the refractory in the back of the combustion chamber of the heat exchanger.
6. Use a vacuum cleaner to remove any accumulation on the boiler heating surfaces. Do not use any solvent.
7. Brush the heat exchanger while dry using a nylon bristle brush. **Caution:** DO NOT use a metal brush. Re-vacuum the heat exchanger.
8. Finish cleaning using a clean cloth dampened with warm water. Rinse out debris with a low pressure water supply.
9. Allow the heat exchanger to thoroughly dry.
10. Remove the field supplied rear refractory cover from the back of the combustion chamber of the heat exchanger and reassemble.
11. Close isolation valves on piping to isolate boiler from system. Attach a hose to the boiler drain and flush boiler thoroughly with clean water by using purging valves to allow water to flow through the water make-up line to the boiler.
12. Perform start-up and check-out procedures in the Check Flame and Combustion - Section 10 - Startup of the Installation and Operation Manual.
13. Replace the access cover and restore boiler to operation.

Table 2-2 Heat Exchanger Cleaning Kits

Model	Kit Number	Part Number	Component Description
400	KIT30063	CTN20005	Rear Refractory Cover
		MSC20083*	Nylon 4" Wheel Brush*
		MSC20084	3mm Allen Wrench
		MSC20086	1/4" x 24" Drill Extension
501 - 801	KIT30064	CTN20005	Rear Refractory Cover
		MSC20083*	Nylon 4" Wheel Brush*
		MSC20085	1/4" x 12" Drill Extension
		MSC20086	1/4" x 24" Drill Extension

⚠ CAUTION

* Do NOT use a metal brush. Only use the kit provided brush or an equivalent replacement nylon brush.

3 Troubleshooting

⚠ WARNING

Label all wires prior to disconnection when servicing controls. Wiring errors can cause improper and dangerous operation. Always disconnect power to the boiler before servicing. Failure to comply could result in severe personal injury, death, or substantial property damage.

⚠ WARNING

Never jumper (bypass) any device except for momentary testing as outlined in the Troubleshooting chart. Severe personal injury, death, or substantial property damage can result.

Before troubleshooting:

- Have the following items:
 - Voltmeter that can check 120 VAC, 24 VAC, and 12 VDC.
 - Continuity checker.
 - Contact thermometer.
- Check for 120 VAC (minimum 102 VAC to maximum 132 VAC) to boiler.
- Make sure thermostat is calling for heat and contacts (including appropriate zone controls) are closed. Check for 24 VAC between thermostat wire nuts and ground.
- Make sure all external limit controls are installed and operating.

Check the following:

- Wire connectors to control module are securely plugged in at the module and originating control.
- Gas pressures:
 - Maximum: 14 inches w.c. (3.5 kPa) (natural and LP) with no flow (lockup) or with boiler on
 - Minimum: 4 inches w.c. (1.0 kPa) (natural), 8 inches w.c. (2.0 kPa) (LP) with gas flowing (verify during boiler startup)

Check control module fuses

NOTICE

ALWAYS check control module fuses before replacing control module or any major components (blower, etc.). If one of these fuses is blown, it can prevent the control module or other components from operating.

- Turn OFF the power to the boiler at the external line switch.
- Remove top access cover.
- Remove the control module cover.
- Inspect fuses F1, F2, and F3, see FIG 3-1 below.

Figure 3-1 Control Module Fuses

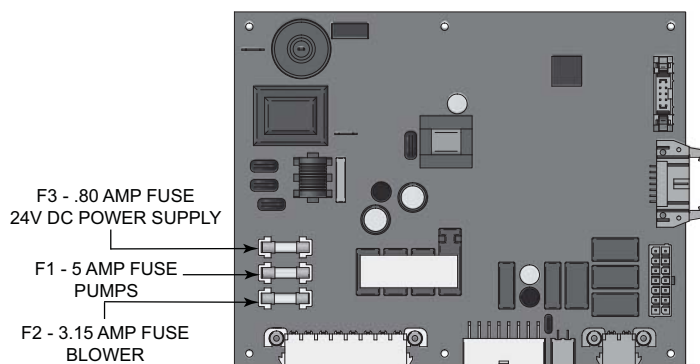

- The boiler is shipped with three (3) spare fuses in a plastic bag attached to the control module cover.
- If necessary, replace open fuse (F3 is .80 amps, F2 is 3.15 amps and F1 is 5 amps).

Note: Fuses F1, F2, and F3 are all slow blow fuses.

⚠ WARNING

Do not jumper fuse or replace with any fuse except as specified. Failure to comply could result in severe personal injury, death, or substantial property damage.

- Install control module cover and top access cover after fuse inspection.
- Restore power to the boiler at the external line switch and verify boiler operation (Section 10 - Start-up in the Knight XL Installation and Operation Manual) after completing boiler service.

3 Troubleshooting

Table 3-1 Troubleshooting Chart - No Display

FAULT	CAUSE	CORRECTIVE ACTION
No Display	- No 120 vac supplied to unit.	<ul style="list-style-type: none"> • Check external line switch, fuse, or breaker. • Check position of ON/OFF switch. Turn switch to the ON position. • Check 120 vac through the ON/OFF switch. • Check wiring harness connection between display board and main control board. Connect harness at both points.
	- No voltage through the switch.	<ul style="list-style-type: none"> • Replace switch.
	- Bad display board.	<ul style="list-style-type: none"> • Replace board.
	- Bad main control board.	<ul style="list-style-type: none"> • Replace the main control board.
	- Blown fuse.	<ul style="list-style-type: none"> • Replace fuse F3 on the main control board, see page 33 of this manual.
No Burner Operation	- Main control board temperature set point satisfied.	<ul style="list-style-type: none"> • Review temperature setting.
	- Remote thermostat satisfied.	<ul style="list-style-type: none"> • Review remote thermostat setting.
	- Outside air temperature above Warm Weather Shutdown (WWSD) set point for main control board.	<ul style="list-style-type: none"> • Check location of outside air sensor. Check resistance of outdoor air sensor and compare to Table 3-2B on page 35 of this manual.
	- Unit locked out on fault.	<ul style="list-style-type: none"> • Consult display for specific fault. Refer to fault descriptions on page 37 of this manual for corrective actions.
Unit Does Not Modulate Above 50%	- Ramp delay active.	<ul style="list-style-type: none"> • Check ramp delay parameter settings. Optional PC software required.
		<ul style="list-style-type: none"> • Turn ramp delay feature off. See page 23 of this manual for instructions on how to turn this feature off.
	- Boiler controlled by BMS.	<ul style="list-style-type: none"> • Check BMS parameter settings. Optional PC software required.
	- Flue sensor open.	<ul style="list-style-type: none"> • Verify that the flue sensor is located in the flue outlet.
		<ul style="list-style-type: none"> • Check wiring connections at the flue sensor. • Check the resistance of the flue sensor and compare to Table 3-2D on page 35 of this manual.

3 Troubleshooting *(continued)*

Checking temperature sensors

The boiler temperature sensors (inlet water, outlet water, system water, flue, and outdoor air) are all resistance type devices. The following tables show the correct values for the sensors at various temperatures. Use an ohmmeter to read the resistance of the sensor at a known temperature. If the resistance of the sensor does not closely match its corresponding table, replace the sensor.

It is important to note that the flue and outlet water sensors have two temperature sensing devices in one housing. These devices are designated as S1a/S1b, outlet sensor and S3a/S3b, flue sensor. Please reference the wiring diagram in the Knight XL Installation and Operation Manual for correct terminal location.

Table 3-2A - Inlet Water/System Sensor Resistance vs. Temperature

Temperature	Resistance	Temperature	Resistance
50	18,780	158	1,990
68	12,263	176	1,458
86	8,194	194	1,084
104	5,592	212	817
122	3,893		
140	2,760		

Table 3-2B - Outdoor Air Sensor Resistance vs. Temperature

Temperature	Resistance	Temperature	Resistance
-50	490,813	20	46,218
-40	336,606	30	34,558
-30	234,196	40	26,099
-20	165,180	50	19,900
10	118,018	60	15,311
0	85,362	70	11,883
10	62,465	80	9,299

Table 3-2C - Outlet Water Sensor Resistance vs. Temperature

S1a (Wire Color - R/BK and Y)				S1b (Wire Color - G and Y)			
Temperature	Resistance	Temperature	Resistance	Temperature	Resistance	Temperature	Resistance
50	19,553	158	2,004	50	40,030	158	3,478
68	12,690	176	1,464	68	25,030	176	2,492
86	8,406	194	1,084	86	16,090	194	1,816
104	5,715	212	816	104	10,610	212	1,344
122	3,958			122	7,166		
140	2,786			140	4,943		

Table 3-2D - Flue Sensor Resistance vs. Temperature

S3a (Wire Color - W/B and Y)				S3b (Wire Color - PR and Y)			
Temperature	Resistance	Temperature	Resistance	Temperature	Resistance	Temperature	Resistance
50	40,030	158	3,478	50	258,500	158	16,870
68	25,030	176	2,492	68	125,500	176	12,000
86	16,090	194	1,816	86	80,220	194	8,674
104	10,610	212	1,344	104	52,590	212	6,369
122	7,166			122	35,270		
140	4,943			140	24,160		

3 Troubleshooting

Table 3-3 Troubleshooting Chart - Noisy System

FAULT	CAUSE	CORRECTIVE ACTION
Noisy Operation	- Supply gas problem. Natural gas pressures should be between 4 inches w.c. and 14 inches w.c. LP gas pressures should be between 8 inches w.c. and 14 inches w.c.	• Refer to Section 7 - Gas Connections of the Knight XL Installation and Operation Manual for detailed information concerning the gas supply.
	- Gas/air mixture problem.	• Refer to the Gas Valve Adjustment Procedure on page 45 of this manual for the proper gas valve setting. Verify that the vent/air intake lengths do not exceed the maximum listed in the General Venting section of the Knight XL Installation and Operation Manual.
	- Dirty/damaged burner.	• Refer to page 31 in this manual for the burner removal and inspection procedure. Clean or replace the burner as necessary.
	- Low water flow through the heat exchanger.	• Refer to Section 6 - Hydronic Piping of the Knight XL Installation and Operation Manual for minimum flow rates. Verify that the boiler is piped in a primary/secondary fashion and that the boiler and system pump are running on a call for heat.
	- Air in the piping system.	• Properly purge all air from the piping system.
	- Low system water pressure.	• Verify system pressure is a minimum of 12 psi.
No Pump Operation - Boiler Pump System Pump or DHW Pump	- Blown fuse.	• Replace fuse F1 on the control board, see page 33 of this manual. Note: Make sure pump amperage does not exceed 1.8 amps.
	- Faulty pump.	• Replace pump.
	- Internal fault on control board.	• Replace main control board.
Relief Valve Opening	- System pressure exceeds relief valve setting.	• Lower the system pressure below the 30 psi rating of the supplied relief valve or replace the standard relief valve with a higher rated valve up to the maximum pressure of the heat exchanger. • Improperly sized expansion tank.

3 Troubleshooting *(continued)*

Table 3-4 Troubleshooting Chart - Fault Messages Displayed on Boiler Interface

FAULT	DESCRIPTION	CORRECTIVE ACTION
Gas Pressure SW (will require a manual reset once the condition has been corrected. Press the RESET button on the SMART SYSTEM display to reset.)	Either the optional manual reset low gas pressure switch or the optional manual reset high gas pressure switch tripped.	<ul style="list-style-type: none"> • Reset the pressure switches. • Measure the supply gas pressure to determine cause of failure. Natural gas pressures should be between 4 - 14 inches w.c. and LP gas pressures should be between 8 - 14 inches w.c. • Refer to Section 7 - Gas Connections of the Knight XL Installation and Operation Manual for detailed information concerning the gas supply. • Correct the supply gas pressure if necessary. • Check for a loose or misplaced jumper if pressure switches are not installed.
Flow Switch/LWCO (will require a manual reset once condition has been corrected. Press the RESET button on the SMART SYSTEM display to reset.)	Either the optional flow switch or the optional low water cutoff is not making.	<ul style="list-style-type: none"> • Check boiler pump operation on a call for heat. • Check for closed valves or obstructions in the boiler piping. • Verify system is full of water and all air has been purged from the system. • Check for loose or misplaced jumpers if flow switch or LWCO is not installed.
	Blown fuse.	<ul style="list-style-type: none"> • Replace fuse F3 on the control board, see page 33 of this manual.
Blocked Drain SW (will require a manual reset once condition has been corrected. Press the RESET button on the SMART SYSTEM display to reset.)	The blocked drain switch has detected excessive condensate build up inside the unit.	<ul style="list-style-type: none"> • Check condensate tube from unit to floor drain for proper installation and obstructions. • Inspect condensate trap for blockage. Clean if necessary. • Check for loose wiring connection at wire harness plug. • Bad blocked drain switch. Replace switch.
APS Open (will require a manual reset once the condition has been corrected. Press the RESET button on the SMART SYSTEM display to reset.)	Air pressure switch contacts are open.	<ul style="list-style-type: none"> • Check the wiring connections to switch. Wires should be connected to the common and normally closed terminals. • Air intake lengths exceed the maximum allowed lengths. Refer to Section 3 - General Venting of the Knight XL Installation and Operation Manual for proper lengths. • Check for obstruction or blockage in the air intake pipes or at terminations. • Check reference hoses connected to the air pressure switch for blockage or obstruction. • Inspect the burner. Reference page 31 of this manual for removal and cleaning procedures. Replace if necessary. • Inspect the heat exchanger. Reference page 32 of this manual for removal and cleaning procedures. Replace if necessary. • Faulty air pressure switch. Replace switch.

3 Troubleshooting

Table 3-4 (continued from previous page) Troubleshooting Chart - Fault Messages Displayed on Boiler Interface

FAULT	DESCRIPTION	CORRECTIVE ACTION
<p>Anti-cycling</p>	<p>The main control board has received a call for heat too quickly after the previous call for heat has ended.</p>	<ul style="list-style-type: none"> • The control board will release the call for heat after a set time period. • The control board will release the call for heat if the outlet temperature drops too quickly.
<p>Flame Fail Ign (will require a manual reset once the condition has been corrected. Press the RESET button on the SMART SYSTEM display to reset.)</p>	<p>The unit has failed to prove main burner ignition after four (4) attempts.</p>	<ul style="list-style-type: none"> • Inspect spark electrode and associated wiring for damage and connection. Reference page 31 of this manual for removal and cleaning procedures. Replace if necessary. • Check for proper electrical grounding of the unit. • Check incoming supply gas pressure. Natural gas pressures should be between 4 - 14 inches w.c. and LP gas pressures should be between 8 - 14 inches w.c. Refer to Section 7 - Gas Connections of the Knight XL Installation and Operation Manual for detailed information concerning the gas supply. • Verify that the plastic hose from the gas valve to the air inlet is connected and is not damaged. • Verify that the vent/air intake pipes are correctly installed and that there are no obstructions. • Check for 24 vac to the gas valve at the 2-pin connection on the side of the main control board during the ignition attempt. If no voltage is present, replace the main control board. • If 24 vac is present at the main control board, check the wiring between the main control board and the gas valve. Replace the wiring if necessary. Do not disconnect the wiring from the gas valve and attempt to measure voltage at that point. The main control board can detect if the gas valve is not connected and will display the Gas Valve or Gas Valve Fail fault. • If 24 vac is present, check the outlet of the valve to ensure the valve is flowing gas. With a manometer connected to the outlet tap of the gas valve, when the unit is in the prepurge period, there should be a negative pressure present. When the valve is energized a change in pressure should occur. If the pressure change does not occur, the gas valve is not opening. Replace the gas valve. • Inspect flame sensor and associated wiring. Reference page 31 of this manual for removal and cleaning procedures. Replace if necessary. • Inspect the burner. Reference page 31 of this manual for removal and cleaning procedures. Replace if necessary. • Replace the main control board.

3 Troubleshooting *(continued)*

Table 3-4 (continued from previous page) *Troubleshooting Chart - Fault Messages Displayed on Boiler Interface*

FAULT	DESCRIPTION	CORRECTIVE ACTION
<p>Flame Sequence (will require a manual reset once the condition has been corrected. Press the RESET button on the SMART SYSTEM display to reset.)</p>	<p>The flame detector circuit is seeing a flame signal while no flame is present.</p>	<ul style="list-style-type: none"> • Check supply voltage for proper polarity. • Check external wiring for voltage feedback. • Check the flame rod and make sure it is clean. • Check the internal wiring for bad connections. • Replace main control board.
<p>Auto Reset High Limit</p>	<p>The outlet water temperature has exceeded the setting of the automatic reset high limit.</p>	<ul style="list-style-type: none"> • Verify that the system is full of water and that all air has been properly purged from the system. • Verify that the boiler is piped properly into the heating system. Refer to Section 6 - Hydronic Piping of the Knight XL Installation and Operation Manual for the proper piping methods for the Knight XL boiler. • Check 120 vac to boiler pump motor on a call for heat. If voltage is not present, check wiring back to the main control board. • Replace the main control board if necessary. • If 120 vac is present on a call for heat and the boiler pump is not operating, replace the pump. • If the system pump is a variable speed pump, ensure that the system flow is not less than the boiler flow. • If operating on something other than an outlet sensor, check temperature setting of the main control board. • If the optional manual reset high limit has tripped, check setting of the device. • Check resistance of water sensors and compare to Table 3-2A on page 35 of this manual. Replace sensor if necessary. • Replace high limit.
<p>Fan Low OR Fan Speed Low (will require a manual reset once the condition has been corrected. Press the RESET button on the SMART SYSTEM display to reset.)</p>	<p>The actual fan RPM is 30% lower than what is being called for.</p>	<ul style="list-style-type: none"> • Vent/air intake lengths exceed the maximum allowed lengths. Refer to Section 3 - General Venting of the Knight XL Installation and Operation Manual for proper lengths. • Check for obstruction or blockage in the vent/air intake pipes or at terminations. • Check the wiring connections at the fan and at the main control board. • Replace the fan. • Replace the main control board.
	<p>Blown fuse.</p>	<ul style="list-style-type: none"> • Replace fuse F2 on the control board, see page 33 of this manual.

3 Troubleshooting

Table 3-4 (continued from previous page) *Troubleshooting Chart - Fault Messages Displayed on Boiler Interface*

FAULT	DESCRIPTION	CORRECTIVE ACTION
<p>GV/Relay Fail (will require a manual reset once the condition has been corrected. Press the RESET button on the SMART SYSTEM display to reset.)</p>	<p>The main control board did not detect the gas valve.</p>	<ul style="list-style-type: none"> • Check wiring harness connection at the gas valve and at the main control board. • Replace the gas valve wire harness. • Replace the gas valve. • Replace the main control board.
<p>Fan High OR Fan Speed High (will require a manual reset once the condition has been corrected. Press the RESET button on the SMART SYSTEM display to reset.)</p>	<p>The actual fan RPM is 30% higher than what is being called for.</p>	<ul style="list-style-type: none"> • Vent/air intake lengths exceed the maximum allowed lengths. Refer to Section 3 - General Venting of the Knight XL Installation and Operation Manual for proper lengths. • Check for obstruction or blockage in the vent/air intake pipes or at terminations. • Check the wiring connections at the fan and at the main control board. • Replace the fan. • Replace the main control board.
<p>Sensor Open (will require a manual reset once the condition has been corrected. Press the RESET button on the SMART SYSTEM display to reset.)</p>	<p>Either the inlet water or outlet water temperature sensor has been disconnected.</p>	<ul style="list-style-type: none"> • Check the sensors and their associated wiring. Repair or replace the sensor or wiring if damaged. • Measure the resistance of the sensors and compare the resistance to the tables on page 35 of this manual. • Replace the sensor if necessary.
<p>Sensor Shorted (will require a manual reset once the condition has been corrected. Press the RESET button on the SMART SYSTEM display to reset.)</p>	<p>Either the inlet water or outlet water temperature sensor has been shorted.</p>	<ul style="list-style-type: none"> • Check the sensors and their associated wiring. Repair or replace the sensor or wiring if damaged. • Measure the resistance of the sensors and compare the resistance to the tables on page 35 of this manual. • Replace the sensor if necessary.
<p>Louver Proving Sw (will require a manual reset once the condition has been corrected. Press the RESET button on the SMART SYSTEM display to reset.)</p>	<p>An optional remote proving switch is not making.</p>	<ul style="list-style-type: none"> • Check function of remote devices. • Check for loose or misplaced jumper if auxiliary proving switch is not installed.

3 Troubleshooting *(continued)*

Table 3-4 (continued from previous page) *Troubleshooting Chart - Fault Messages Displayed on Boiler Interface*

FAULT	DESCRIPTION	CORRECTIVE ACTION
Flue Temp High	The stack temperature has exceeded the set parameters for the boiler.	<ul style="list-style-type: none"> • Inspect the heat exchanger. Reference page 32 of this manual for the procedure on how to clean the flue side of the heat exchanger. • Inspect the flue sensor and associated wiring. Measure the resistance of the flue sensor and compare to Table 3-2D on page 35 of this manual. Replace the sensor if necessary. • Verify that the vent/air intake pipes are properly installed and that there are no obstructions. • Replace the main control board.
Delta T High	The temperature rise across the heat exchanger has exceeded the set parameters for the boiler.	<ul style="list-style-type: none"> • Verify that the system is full of water and that all air has been properly purged from the system. • Verify that the boiler is piped properly into the heating system. Refer to Section 6 - Hydronic Piping of the Knight XL Installation and Operation Manual for the proper piping methods for the Knight XL boiler. • Check for 120 vac to the boiler pump motor on a call for heat. If voltage is not present, check the wiring back to the main control board. Replace the main control board if necessary. • If 120 vac is present on a call for heat and the boiler pump is not operating, replace the pump. • Verify that the boiler pump is set to the proper speed or that the pump is the proper size. Reference Section 6 - Hydronic Piping of the Knight XL Installation and Operation Manual for boiler pump specifications.
Outlet Temp High	Outlet water temperature has exceeded the maximum outlet water temperature.	<ul style="list-style-type: none"> • Verify that the system is full of water and that all air has been properly purged from the system. • Verify that the boiler is piped properly into the heating system. Refer to Section 6 - Hydronic Piping of the Knight XL Installation and Operation Manual for the proper piping methods for the Knight XL boiler. • Check for 120 vac to the boiler pump motor on a call for heat. If voltage is not present, check wiring back to the main control board. Replace the main control board if necessary. • If 120 vac is present on a call for heat and the boiler pump is not operating, replace the pump.

3 Troubleshooting

Table 3-4 (continued from previous page) Troubleshooting Chart - Fault Messages Displayed on Boiler Interface

FAULT	DESCRIPTION	CORRECTIVE ACTION
Outlet Temp High (continued)	Outlet water temperature has exceeded the maximum outlet water temperature.	<ul style="list-style-type: none"> • Verify that the boiler pump is set to the proper speed or that the boiler pump is the proper size. Reference Section 6 - Hydronic Piping of the Knight XL Installation and Operation Manual for boiler pump specifications. • Replace the main control board.
Rem Ctrl Flt	External control is cycling too often.	<ul style="list-style-type: none"> • Check set point of the external control. • Check the wiring between the external control and the unit. • Replace the control.
Parameters Progr (will require a manual reset once the condition has been corrected. Press the RESET button on the SMART SYSTEM display to reset.)	After downloading parameters from a laptop, the main control board must be reset.	<ul style="list-style-type: none"> • Press the ENTER/RESET button on the SMART SYSTEM display panel.
Service Blk	While the unit is in Service Mode, the outlet temperature has exceeded 185°F.	<ul style="list-style-type: none"> • Establish a heating load to remove the heat from the boiler loop. • Verify that the system is full of water and that all air has been properly purged from the system. • Verify that the boiler is piped properly into the heating system. Refer to Section 6 - Hydronic Piping of the Knight XL Installation and Operation Manual for the proper piping methods for the Knight XL boiler. • Check 120 vac to the boiler pump motor on a call for heat. If voltage is not present, check the wiring back to the main control board. Replace the main control board if necessary. • If 120 vac is present on a call for heat and the boiler pump is not operating, replace the pump. • Verify that the boiler pump is set to the proper speed or that the boiler pump is the proper size. Reference Section 6 - Hydronic Piping of the Knight XL Installation and Operation Manual for boiler pump specifications.

3 Troubleshooting *(continued)*

Table 3-4 (continued from previous page) *Troubleshooting Chart - Fault Messages Displayed on Boiler Interface*

FAULT	DESCRIPTION	CORRECTIVE ACTION
Low 24 vac	120 vac input to the main control board has dropped below 80 vac.	<ul style="list-style-type: none"> • Check 120 vac supply to the transformer. • Check wiring connections at the low voltage terminal strip. • Check the wire size/length to remote devices. • Replace the transformer.
Watch Dog Error	The main control board has detected an internal fault.	<ul style="list-style-type: none"> • Replace the main control board.
Write EEPROM	The main control board has detected an internal fault.	<ul style="list-style-type: none"> • Replace the main control board.
CRC Parameters	The main control board has detected an internal fault.	<ul style="list-style-type: none"> • Replace the main control board.
No Error Stored	The main control board has detected an internal fault.	<ul style="list-style-type: none"> • Replace the main control board.

3 Troubleshooting

Combustion Analysis Procedure

1. Turn the main power off to the boiler by placing the "On/Off" switch in the OFF position.
2. Remove the flue temperature sensor from the flue pipe connection. **Note:** Combustion measurements will be made at this point.
3. Turn the main power on to the boiler by placing the "On/Off" switch in the ON position.
4. Place the boiler into the active position by pressing the RIGHT SELECT [ON] key (see page 7).
5. Locate the pinhole button below the RESET button on the display board (see page 7). Insert a thin wire (such as a paper clip) into the hole and press the button once and hold for 5 seconds to place the boiler into Service Mode. In Service Mode the boiler will fire at ignition speed and will then modulate up to full fire.
6. Remove the flue temperature sensor. Insert the probe from a combustion analyzer into the hole left by the removal of the flue temperature sensor.
7. Once the boiler has modulated up to full fire, measure the combustion. The values should be in the range listed in Table 3-6 above. The CO levels should be less than 150 ppm for a properly installed unit.

If the combustion is not within the specified range, reference the chart below for possible causes and corrective actions.

Table 3-6 Flue Products

Natural Gas		Propane	
CO ₂	O ₂	CO ₂	O ₂
8.0% - 10%	3.0% - 6.5%	9.0% - 11%	4.1% - 6.9%

8. Once the combustion analysis is complete, test the safety shutoff device by turning the manual shutoff valve to the OFF position and ensuring that the boiler shuts down and registers an alarm. Open the manual shutoff valve, reset the control, and return to Service Mode.
9. Turn the main power off to the boiler and replace the flue temperature sensor into the flue pipe connection.
10. Place the boiler back into normal operation.

⚠ WARNING

You must replace the flue gas temperature sensor to prevent flue gas spillage into the room. Failure to comply could result in severe personal injury, death, or substantial property damage.

Table 3-5 Troubleshooting Chart - Combustion Levels

POSSIBLE CAUSE	CORRECTIVE ACTION
Vent/Air Intake Length or Obstruction	<ul style="list-style-type: none"> • Refer to Section 3 - General Venting of the Knight XL Installation and Operation Manual for the proper venting and air intake methods for the Knight XL boiler. • Check for obstructions at the vent/air intake terminals.
Gas Supply Pressure	<ul style="list-style-type: none"> • Refer to Section 7 - Gas Connections of the Knight XL Installation and Operation Manual for the proper gas supply for the Knight XL boiler.
Dirty/Damaged Burner	<ul style="list-style-type: none"> • Refer to page 31 of this manual for burner removal and cleaning procedures. • Replace burner if necessary.
Gas Valve Adjustment	<ul style="list-style-type: none"> • Refer to page 45 of this manual for the gas valve adjustment procedure.

3 Troubleshooting *(continued)*

Gas valve adjustment procedure

If adjustment of the gas valve is deemed necessary, use the following procedures: (**Note:** The procedures below are model specific.)

CAUTION

Under normal operating conditions this valve should not need adjusting.

Model 400

Locate the throttle adjustment screw on the top of the gas valve, see FIG. 3-2. Using a screwdriver, turn the screw 1/8 turn **counterclockwise** to increase CO₂ levels or 1/8 turn **clockwise** to decrease CO₂ levels. After one adjustment on the valve, follow the Combustion Analysis Procedure on page 44 of this manual to measure the combustion.

If combustion is still not within the specified range, repeat the procedure. This procedure **SHOULD NOT** be performed more than four (4) times. If after four (4) adjustments and the combustion is still not within the specified range, revisit the possible causes in Table 3-5 on page 44 or replace the gas valve.

Figure 3-2 Gas Valve Adjustment: Model 400

THROTTLE ADJUSTMENT
SCREW

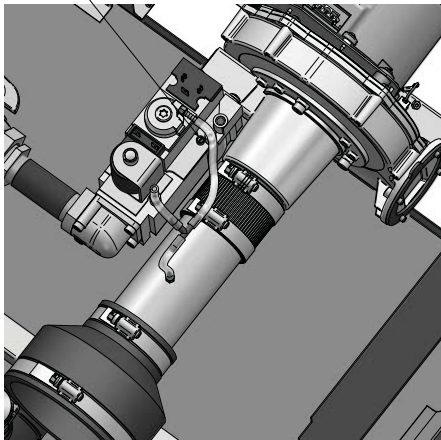

Model 501

Locate the throttle adjustment screw on top of the gas valve, see FIG. 3-3. Using a screwdriver, turn the screw a 1/4 turn **counterclockwise** to increase CO₂ levels or a 1/4 turn **clockwise** to decrease CO₂ levels. After one adjustment on the valve, follow the Combustion Analysis Procedure on page 44 of this manual to measure the combustion.

If combustion is still not within the specified range, repeat the procedure. This procedure **SHOULD NOT** be performed more than four (4) times. If after four (4) adjustments and the combustion is still not within the specified range, revisit the possible causes in Table 3-5 on page 44 or replace the gas valve.

Figure 3-3 Gas Valve Adjustment: Model 501

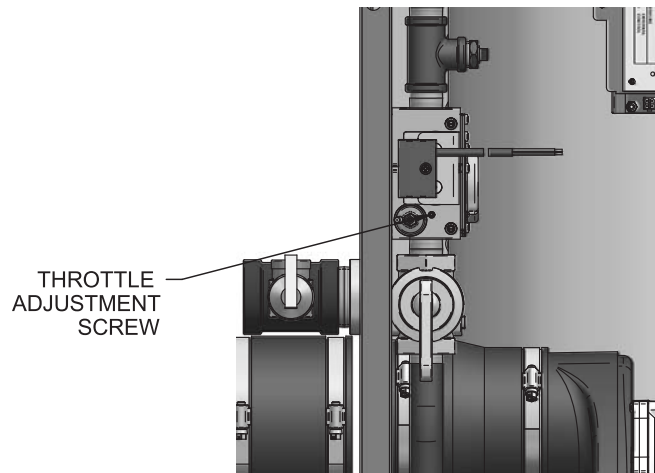

Models 601 - 801

Locate the throttle adjustment screw on top of the gas valve, see FIG. 3-4. Using an Allen wrench, turn the screw a 1/4 turn **counterclockwise** to increase CO₂ levels or a 1/4 turn **clockwise** to decrease CO₂ levels. After one adjustment on the valve, follow the Combustion Analysis Procedure on page 44 of this manual to measure the combustion.

If combustion is still not within the specified range, repeat the procedure. This procedure **SHOULD NOT** be performed more than four (4) times. If after four (4) adjustments and the combustion is still not within the specified range, revisit the possible causes in Table 3-5 on page 44 or replace the gas valve.

Figure 3-4 Gas Valve Adjustment: Models 601 - 801

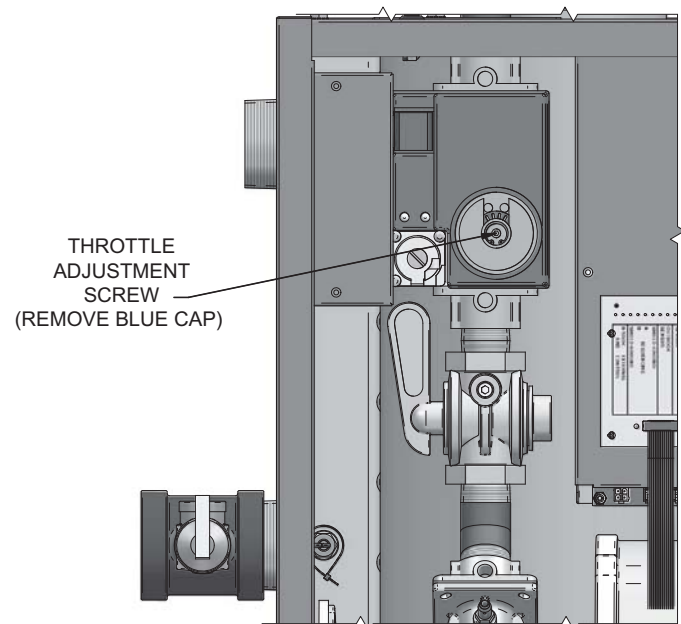

NOTES



Revision Notes: Revision A (ECO #C05747) initial release. Reflects the new model numbers for the Knight XL upgrade.

Revision B (ECO #C06234) reflects changes made to the Service Notification parameter.