

# CREST<sup>®</sup>

CONDENSING BOILER

## Service Manual

Models: 1.5 - 2.0 - 2.5 - 3.0 - 3.5



**⚠ WARNING**

This manual must only be used by a qualified heating installer / service technician. Read all instructions, including this manual and the Crest Installation and Operation Manual, before installing. Perform steps in the order given. Failure to comply could result in severe personal injury, death, or substantial property damage.

Save this manual for future reference.

# Contents

<b>CONTENTS</b> .....	2	<b>2. MAINTENANCE</b>	
Hazard Definitions.....	2	Maintenance and Annual Startup.....	31-35
<b>PLEASE READ BEFORE PROCEEDING</b> .....	3	<b>3. TROUBLESHOOTING</b>	
Handling Ceramic Fiber Materials.....	3	Before Troubleshooting.....	36
When servicing boiler .....	4	Check Control Module Fuses .....	36
Boiler operation.....	4	Table 3A - Troubleshooting Chart - No Display.....	37
Boiler water.....	4	Checking Temperature Sensors .....	38
Freeze protection fluids .....	4	Table 3F - Troubleshooting Chart - Noisy System .....	39
WHAT IS IN THIS MANUAL .....	5	Table 3G - Troubleshooting Chart - Fault Messages .	40-51
<b>1. SERVICE</b>		Combustion Analysis Procedure .....	52
Boiler Piping.....	6	Table 3H - Troubleshooting Chart - Combustion Levels	52
SMART TOUCH Display (Home Screen) .....	7	Table 3I - Flue Products.....	52
Control Inputs .....	8	Gas Valve Adjustment Procedure.....	53
Control Outputs.....	9	Revision Notes .....	Back Cover
General Operation .....	10-11		
Table 1A - Sequence of Operation .....	12		
Table 1B - Parameter Table.....	13-17		
Viewable and Changeable Control Parameters.....	18-25		
Cascade Screen.....	26		
Graph Screen.....	27		
History Screen.....	28-29		
Service Screen.....	30		

## Hazard definitions

The following defined terms are used throughout this manual to bring attention to the presence of hazards of various risk levels or to important information concerning the life of the product.

### **DANGER**

DANGER indicates an imminently hazardous situation which, if not avoided, will result in death or serious injury.

### **WARNING**

WARNING indicates a potentially hazardous situation which, if not avoided, could result in death or serious injury.

### **CAUTION**

CAUTION indicates a potentially hazardous situation which, if not avoided, may result in minor or moderate injury.

### **CAUTION**

CAUTION used without the safety alert symbol indicates a potentially hazardous situation which, if not avoided, may result in property damage.

### **NOTICE**

NOTICE indicates special instructions on installation, operation, or maintenance that are important but not related to personal injury or property damage.

## Please read before proceeding

**⚠ WARNING**

**Installer** – Read all instructions, including this manual and the Crest Installation and Operation Manual, before installing. Perform steps in the order given.

**User** – This manual is for use only by a qualified heating installer/service technician. Refer to the Crest User's Information Manual for your reference.

Have this boiler serviced/inspected by a qualified service technician at least annually.

Failure to comply with the above could result in severe personal injury, death or substantial property damage.

**NOTICE**

When calling or writing about the boiler – Please have the boiler model and serial number from the boiler rating plate.

Consider piping and installation when determining boiler location (see the Crest Installation and Operation Manual).

Any claims for damage or shortage in shipment must be filed immediately against the transportation company by the consignee.

## Handling ceramic fiber materials

### REMOVAL OF COMBUSTION CHAMBER LINING

**⚠ WARNING**

The combustion chamber insulation in this appliance contains ceramic fiber material. Ceramic fibers can be converted to cristobalite in very high temperature applications. The International Agency for Research on Cancer (IARC) has concluded, "Crystalline silica in the form of quartz or cristobalite from occupational sources is carcinogenic to humans (Group 1)." Normal operating temperatures in this appliance are below the level to convert ceramic fibers to cristobalite. Abnormal operating conditions would have to be created to convert the ceramic fibers in this appliance to cristobalite.

The ceramic fiber material used in this appliance is an irritant; when handling or replacing the ceramic materials it is advisable that the installer follow these safety guidelines.

- Avoid breathing dust and contact with skin and eyes.
  - Use NIOSH certified dust respirator (N95). This type of respirator is based on the OSHA requirements for cristobalite at the time this document was written. Other types of respirators may be needed depending on the job site conditions. Current NIOSH recommendations can be found on the NIOSH website at <http://www.cdc.gov/niosh/homepage.html>. NIOSH approved respirators, manufacturers, and phone numbers are also listed on this website.
  - Wear long-sleeved, loose fitting clothing, gloves, and eye protection.
- Apply enough water to the combustion chamber lining to prevent airborne dust.
- Remove the combustion chamber lining from the appliance and place it in a plastic bag for disposal.
- Wash potentially contaminated clothes separately from other clothing. Rinse clothes washer thoroughly.

#### NIOSH stated First Aid.

- Eye: Irrigate immediately.
- Breathing: Fresh air.

## Please read before proceeding

### When servicing boiler –

- To avoid electric shock, disconnect electrical supply before performing maintenance.
- To avoid severe burns, allow boiler to cool before performing maintenance.

### Boiler operation –

- Do not block flow of combustion or ventilation air to the boiler.
- Should overheating occur or gas supply fail to shut off, do not turn off or disconnect electrical supply to circulator. Instead, shut off the gas supply at a location external to the appliance.
- Do not use this boiler if any part has been under water. The possible damage to a flooded appliance can be extensive and present numerous safety hazards. Any appliance that has been under water must be replaced.

### Boiler water –

- Thoroughly flush the system (without boiler connected) to remove sediment. The high-efficiency heat exchanger can be damaged by build-up or corrosion due to sediment.
- Do not use petroleum-based cleaning or sealing compounds in the boiler system. Gaskets and seals in the system may be damaged. This can result in substantial property damage.
- Do not use “homemade cures” or “boiler patent medicines”. Serious damage to the boiler, personnel, and/or property may result.
- Continual fresh make-up water will reduce boiler life. Mineral buildup in the heat exchanger reduces heat transfer, overheats the stainless steel heat exchanger, and causes failure. Addition of oxygen carried in by makeup water can cause internal corrosion. Leaks in boiler piping must be repaired at once to prevent the introduction of makeup water.

### Freeze protection fluids –

- NEVER use automotive antifreeze. Use only inhibited propylene glycol solutions which are specifically formulated for hydronic systems. Ethylene glycol is toxic and can attack gaskets and seals used in hydronic systems.

## What is in this manual?

### Service

#### Near boiler piping

- Typical system components

#### The Crest boiler display

- Display panel readout, buttons and their functions

#### Control module inputs

- Control module inputs and options

#### Control module outputs

- Control module outputs and options

#### General

- How the boiler operates
- How the control module operates
- Access modes -- user and installer
- Sequence of operation -- HWG/space heating

#### Control panel menu access

- Accessing programming mode and locating menus  
(See separate guide covering the PC interface.)

#### Control panel parameter access

- Accessing and changing parameters from the display panel

#### Quick start information -- parameter table

- An index of available adjustments and readouts, where to access them and where to find detailed information.

#### Crest boiler operation

- Initial Setup
- Set Points
- Outdoor Reset
- Ramp Delay
- BMS
- Advanced Setup
- SH Night Setback
- HWG Night Setback
- Cascade
- Pumps
- Service Notification

### Maintenance

- Service and maintenance schedules
- Address reported problems
- Inspect boiler area and boiler interior
- Clean condensate trap
- Check all piping for leaks
- Check air openings
- Flue vent system and air piping
- Check water system
- Check expansion tank
- Check boiler relief valve
- Inspect ignition electrode
- Check ignition ground wiring
- Check all boiler wiring
- Check control settings
- Perform start-up and checks
- Check burner flame
- Check flame signal
- Check flue gas temperature
- General maintenance
- Review with owner
- Cleaning boiler heat exchanger
- Oiled bearing circulators

### Troubleshooting

- Troubleshooting table - No display
- Checking temperature sensors
- Sensor tables
- Troubleshooting table - Fault messages displayed on boiler interface
- Combustion analysis procedure
- Gas valve adjustment procedure

# 1 Service

## Boiler piping

This piping reference is included to specify the *Boiler Piping* specific to the Crest boiler. This piping scheme is important for proper operation of the SMART TOUCH control. See the Crest Installation and Operation Manual for more detailed piping diagrams.

### Single Boiler - Recommended - Primary / Secondary Piping with a Hot Water Generator

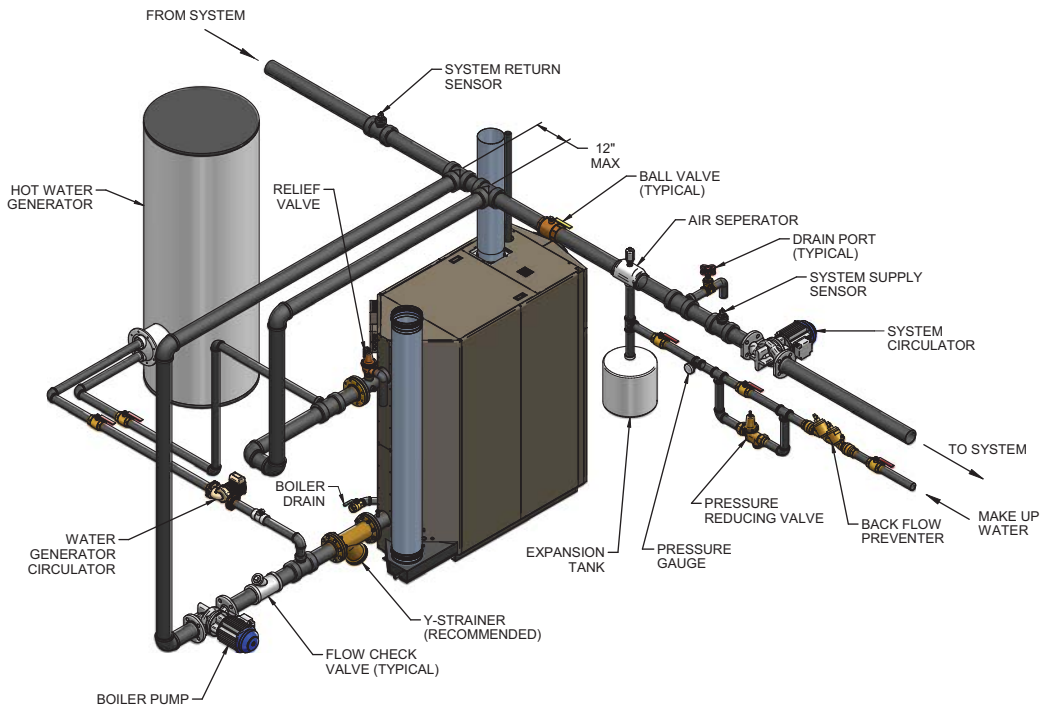

### Single Boiler - Alternate - Full Flow System Piping

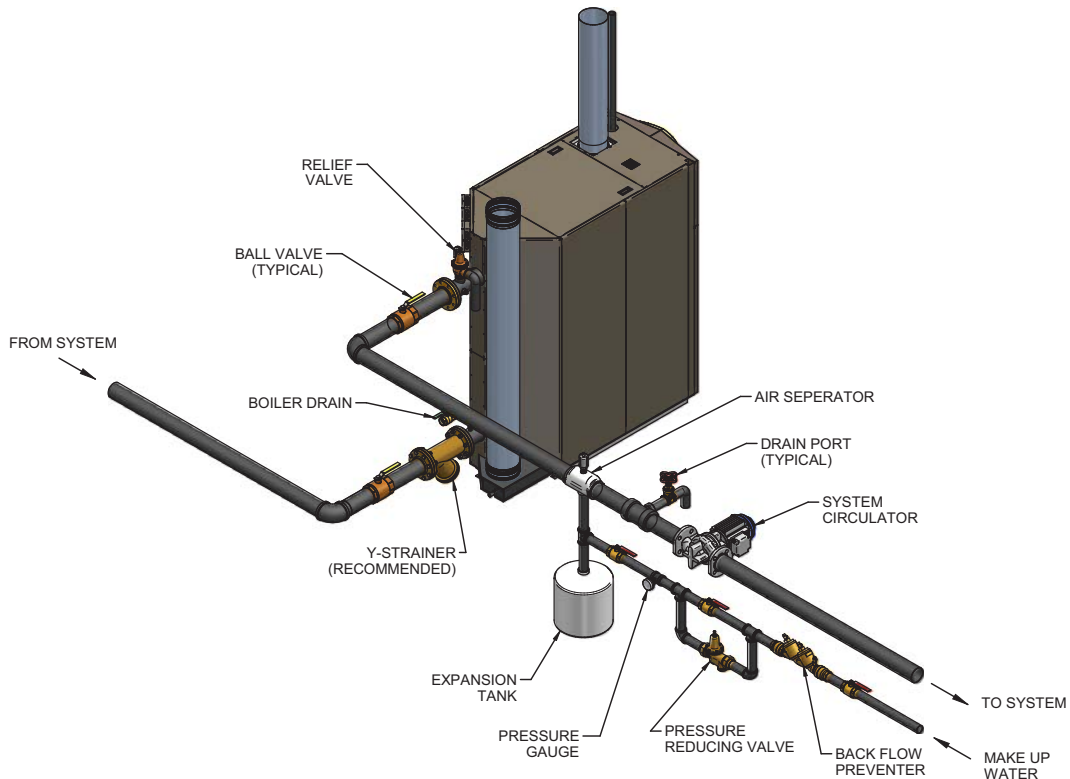

# 1 Service *(continued)*

## SMART TOUCH™

The Home Screen displays status, modulation rate, outlet water temperature, inlet water temperature, flue temperature, system supply temperature, system return temperature, outdoor air temperature, and domestic hot water tank temperature.

The boiler can be started and stopped by pressing the ON/OFF button. The Boiler Status Screen and Main Menu Screen can be accessed by pressing the appropriate button.

### Home Screen

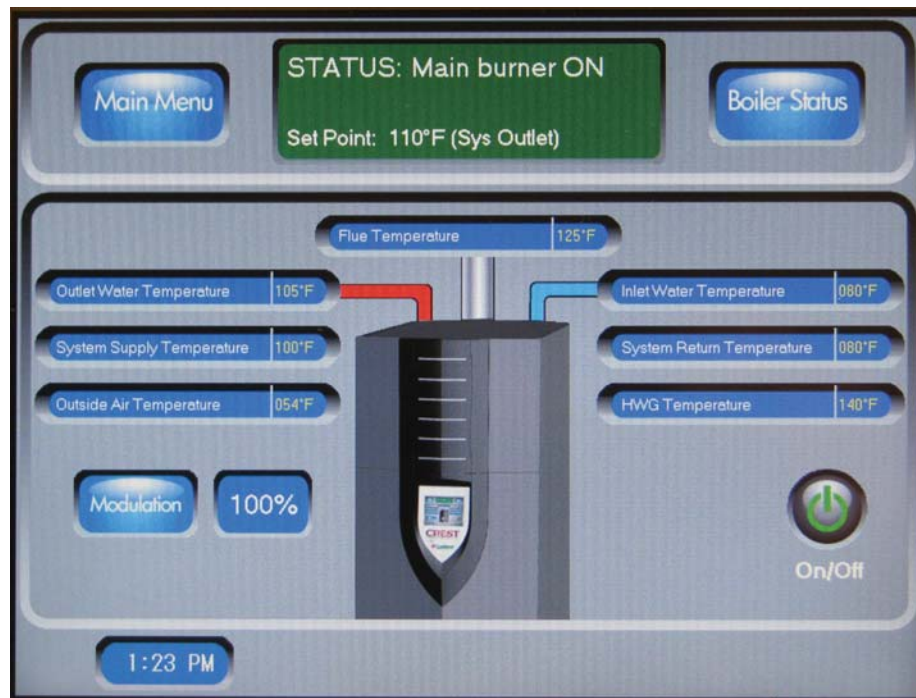

When the ON/OFF switch is turned to the ON position, the first screen visible on the LCD display will be the Home Screen. This screen displays the current status of the Crest boiler. The following items can be viewed or interacted with on the Home Screen:

**On/Off button** - Pressing this button allows the boiler to be placed in either Manual Shutdown Mode or Standby Mode.

**Status** - This line shows the current operating status of the Crest boiler and the current set point.

**Outlet Water Temperature** - This is the boiler outlet temperature.

**Inlet Water Temperature** - This is the boiler inlet temperature.

**System Supply Temperature** - This is the water temperature as measured by the system supply sensor located in the downstream piping (if connected).

**System Return Temperature** - This is the water temperature measured by the system return sensor located in the upstream piping (if connected).

**Outside Air Temperature** - This is the outdoor air temperature (if connected).

**HWG Temperature** - This is the temperature as measured by the tank sensor in the hot water storage tank (if connected).

**Flue Temperature** - Temperature measured by the flue sensor.

**Time** - The time is displayed in the lower left-hand corner of the display. Reference this manual for Night Setback parameters and more information regarding adjusting the date and time.

**Boiler Status button** - Pressing this button brings up the Boiler Status Screen. This screen shows the status of the various safeties, inputs, and outputs to the control module. Reference this manual for more information regarding this screen.

**Main Menu button** - Pressing this button brings up the Main Menu Screen. From this screen navigation to nine (9) other screens is possible.

**Modulation button** - Pressing this button brings up the Modulation Screen. This screen shows overall boiler modulation, individual fan speeds, and flame currents.

**Modulation Percentage** - Displays the current boiler firing rate.



# 1 Service

## Control inputs

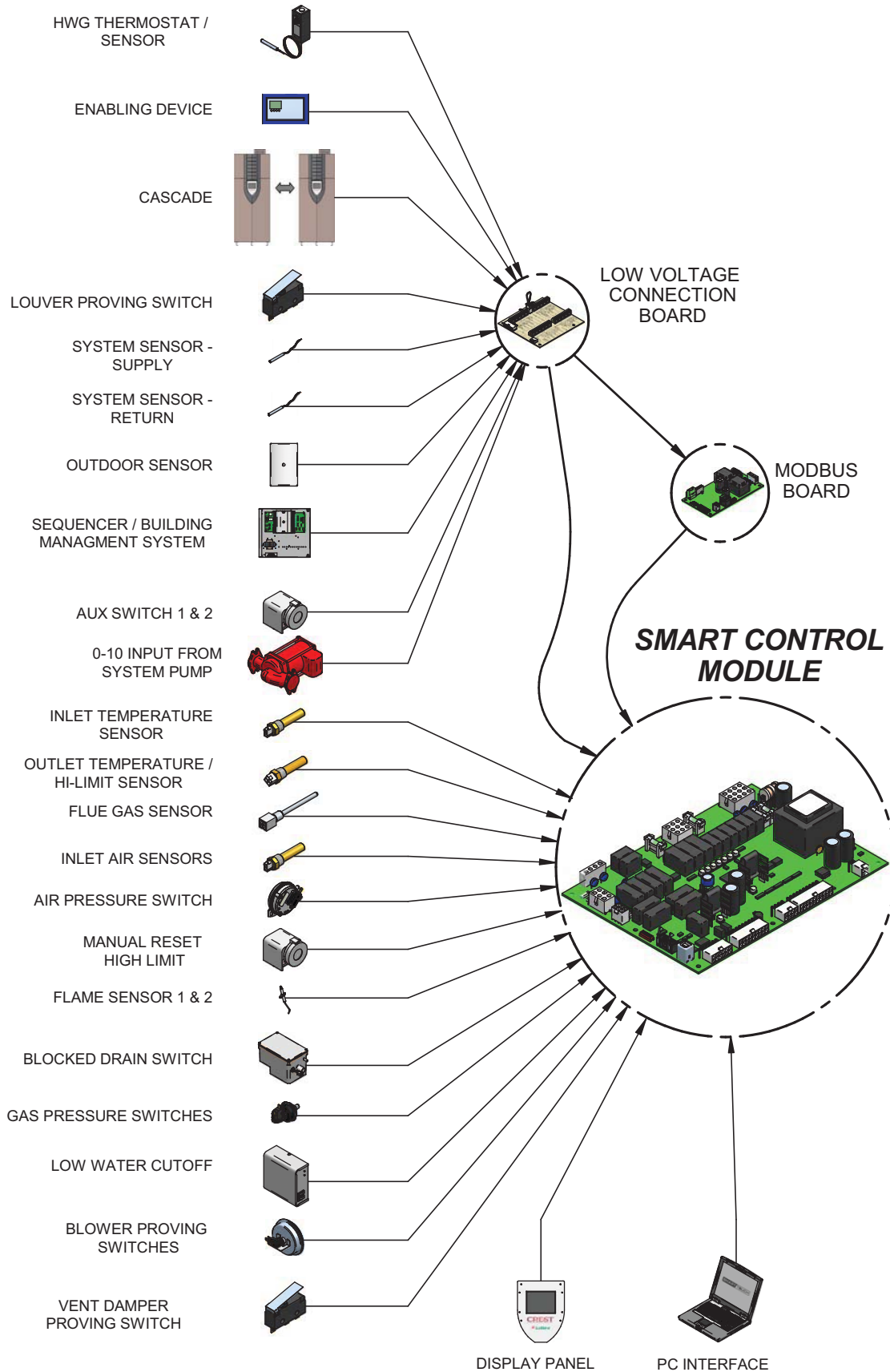



# 1 Service *(continued)*

## Control outputs

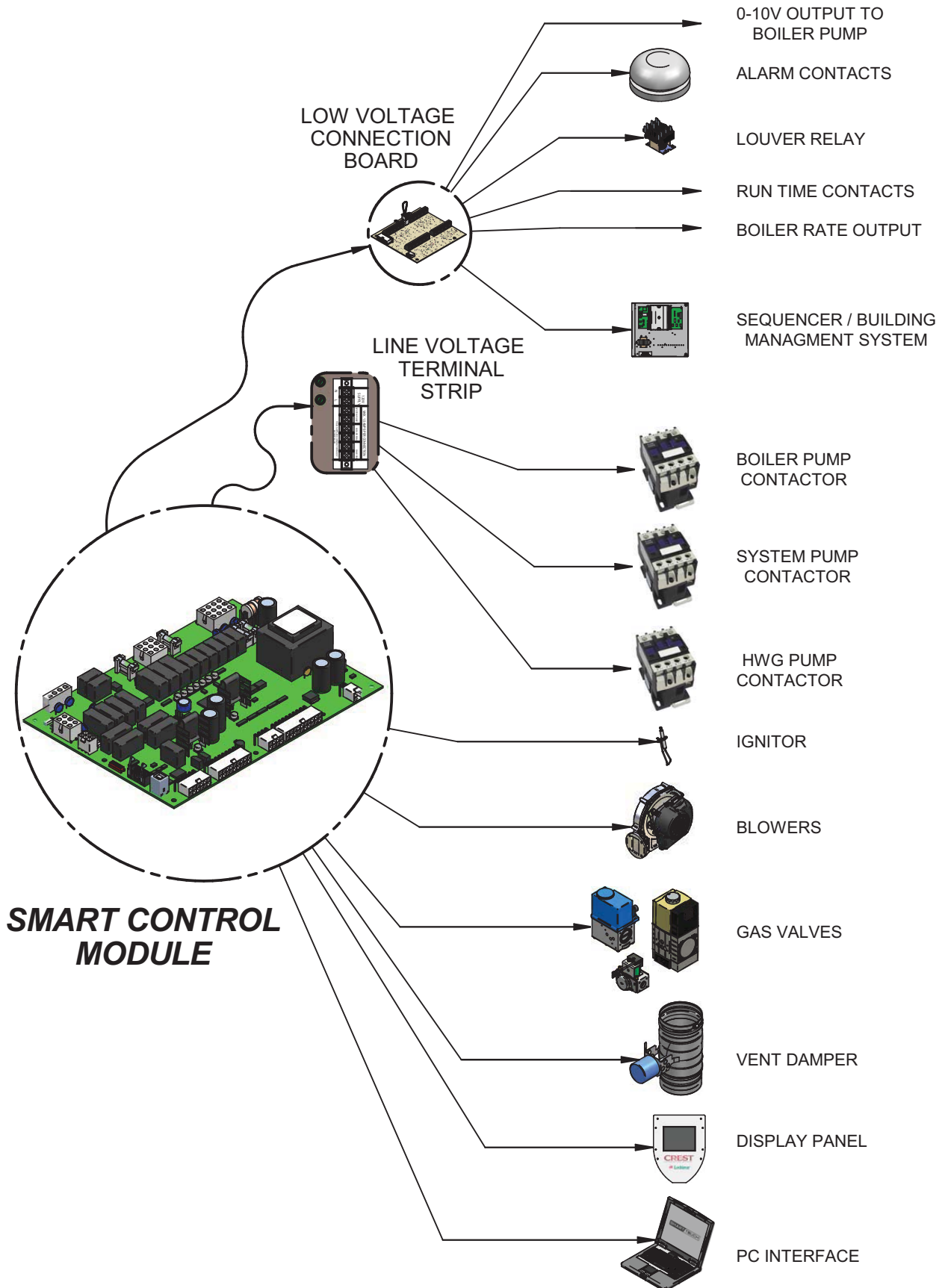

# 1 Service

## General Operation

### How the boiler operates

The Crest uses an advanced stainless steel heat exchanger and electronic control module that allows fully condensing operation. The blowers pull in air and push flue products out of the boiler through the heat exchanger and flue piping. The control module regulates blower speeds to control the boiler firing rate. The gas valves sense the amount of air flowing into the boiler and allow only the right amount of gas to flow.

### How the control modules operate

The Crest boiler is equipped with a SMART TOUCH control module. The SMART TOUCH control module receives inputs from boiler sensors and external devices. The control module activates and controls the blowers and gas valves to regulate heat input and switches the boiler, Hot Water Generator (HWG), and system pumps on and off as needed. The user programs the control module to meet system needs by adjusting control parameters. These parameters set operating temperatures and boiler operating modes.

### Sequence of operation

Table 1A (page 12) shows control module normal sequences of operation for space heating and HWG operation. The combined operation sequence is for a typical application, programmed to provide HWG priority.

### Access modes

#### User

The USER can adjust various space heating and HWG operating variables:

- Navigate to the Initial Setup Screen (FIG. 1-5).
- From the Home Screen (FIG. 1-1), press MAIN MENU, then press SETUP on the Main Menu Screen (FIG. 1-2).
- Press ENTER on the Password Screen (FIG. 1-3) (do not enter any values) and then press INITIAL SETUP on the Setup Screen (FIG. 1-4).

The USER can set the date and time and adjust temperature set points, and outdoor reset points.

Under the ADVANCED SETUP menu, the USER can change the TEMPERATURE UNITS and the LCD BACKLIGHT TIMER.

#### Installer

Most parameters are available only to the INSTALLER, accessible only by entering the installer password (5309) in the Password Screen (see the *User* Section).

Figure 1-1 Home Screen

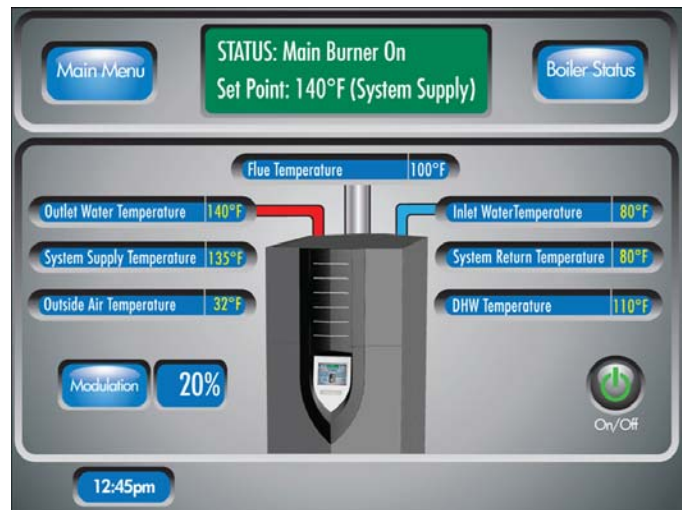
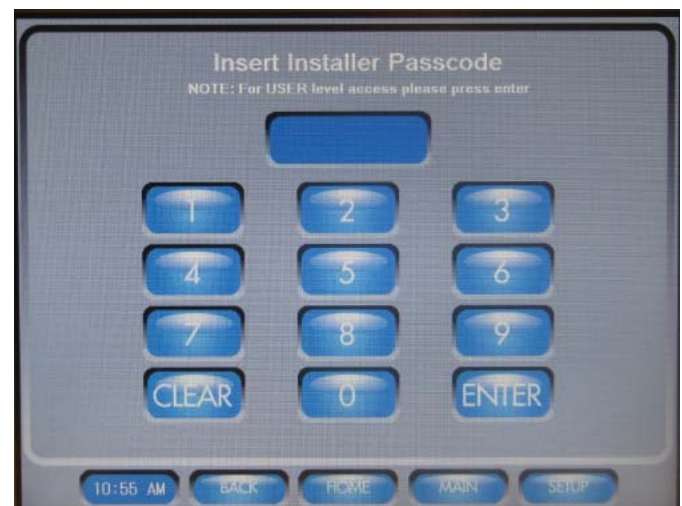

Figure 1-2 Main Menu Screen



Figure 1-3 Password Screen



# 1 Service *(continued)*

**Figure 1-4 Setup Screen**



**Figure 1-5 Initial Setup Screen**

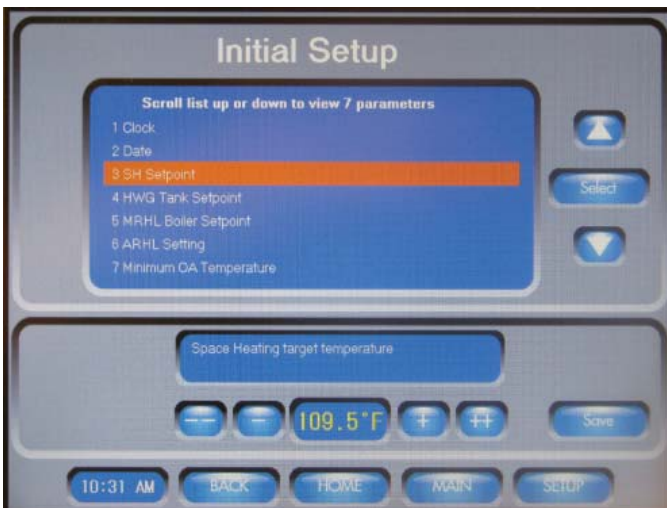

Saving parameters *(reference the Parameter Table - Table 1B on pages 13 - 17 of this manual)*

To adjust and save parameters (reference FIG. 1-5):

To change a parameter, use the arrows next to the parameter list on the Menu Screen to highlight the desired parameter, then press SELECT. A short description of the parameter and its current setting are then displayed on the bottom half of the screen. To adjust the setting, use the buttons to the left and right of the current setting.

**Note:** If the above mentioned buttons to adjust settings do not appear, the correct PASSWORD has not been entered.

Press the SAVE button after adjusting a parameter value. Additional parameter settings can then be adjusted or other navigation buttons can be used to return to previous screens or the Home Screen (FIG. 1-1).

**Note:** The SAVE button MUST BE pressed to ensure proper programming of the control. Failure to press the SAVE button will require all changes to be reprogrammed.

# 1 Service

**Table 1A** Sequence of Operation

## Sequence of operation

**Note:** This unit is equipped with two (2) gas train systems. Gas Train 1 will fire first. If the demand cannot be met by the first gas train, the second gas train (Gas Train 2) will fire.

1.	Upon a call for heat, the control turns on the appropriate pumps (system and boiler pumps for a space heating call, HW pump for a domestic hot water call).
2.	The control confirms that the low water cutoff contacts are closed and energizes the louvers (optional) and damper (optional) relays.
3.	The control confirms that the gas pressure switch, blocked drain switch, limits, louver proving switch (optional) and damper proving switch (optional) contacts close. The Pre-Purge cycle begins.
4.	The control confirms both blowers come up to the desired speed, both blower proving switches close, and the air pressure switch is closed.
5.	Once the Pre-Purge cycle is complete, the control lowers the blower speeds, initiates sparking of the ignition electrode, and opens Gas Valve 1.
6.	After a short wait, the control stops sparking and checks for the presence of flame current through the flame sense electrode.
7.	If the control does not detect flame current, the control will lockout indefinitely, until the RESET button on the touch screen LCD is pressed. Models FB 1500 - 2500 will have one retry.
8.	If the control detects flame current, the control will hold the blower speed constant for a few seconds to allow the flame to stabilize, then begin modulating the firing rate in order to maintain the controlling sensor to the desired set point temperature.
9.	If the current call for heat is for space heating and a HW call for heat becomes active, the control will turn on the HW pump relay output, then turn off the boiler pump. It will then modulate the blower speed in order to maintain the outlet temperature to the desired HW outlet set point temperature.
10.	If the first combustion system in the boiler is unable to maintain the desired set point temperature, the second combustion system in the boiler will be started. Both blowers will modulate to a set speed, and the second gas valve will be energized. The second combustion system will light from the first combustion system. The second flame will be monitored much like the first. Once both combustion systems are firing, the control will work in synchronization to maintain the desired set point temperature. If the heat load should decrease sufficiently, the second combustion system will be shut down.
11.	Once both the space heating and HW calls for heat are satisfied, the control will turn off the gas valve(s) and begin the Post-Purge cycle. Any pumps that are running will begin their respective Pump Delay cycles.
12.	At the end of the Post-Purge cycle, the louver relay contacts will de-energize.
13.	The control verifies that the blowers stop running and the blower proving switches open.
14.	At the end of the Pump Delay cycle(s), the pump(s) will be turned off.

# 1 Service *(continued)*

## Parameter table

**Table 1B** This table lists SMART TOUCH control module parameters and where to access them

Menu	Sub Item	Parameter Name (as shown on the LCD screen)	See Page	Min	Max	Default	User	Installer	
				Value	Value	Value	Access	Access	
INITIAL SETUP	A	1	Clock	18	N/A	N/A	N/A	Yes	Yes
		2	Date	18	N/A	N/A	N/A	Yes	Yes
		3	SH Setpoint	18	32	185	120	Yes	Yes
		4	HWG Tank Setpoint	18	32	185	120	Yes	Yes
		5	MRHL Setpoint	18	32	205	205	Yes	Yes
		6	ARHL Setpoint	18	32	200	200	Yes	Yes
		7	SH Setpoint at Low Outdoor Temp.	19	32	185	180	Yes	Yes
		8	SH Setpoint at High Outdoor Temp.	19	32	185	68	Yes	Yes
		9	Low Outdoor Temperature	19	-22	86	23	Yes	Yes
		10	High Outdoor Temperature	19	-22	86	86	Yes	Yes
		11	Boiler Pump Mode	24	N/A	N/A	N/A	No	Yes
		12	System Pump Mode	24	N/A	N/A	N/A	No	Yes
SETPOINTS	B	1	SH Min User Setpoint	18	32	185	32	No	Yes
		2	SH Max User Setpoint	18	32	185	185	No	Yes
		3	SH Setpoint	18	32	185	125	Yes	Yes
		4	SH Offset	18	0	36	9.9	No	Yes
		5	SH Differential	18	0	72	19.8	No	Yes
		6	HWG Tank Setpoint	18	32	185	120	Yes	Yes
		7	HWG Tank Differential	18	0	10	6.3	No	Yes
		8	MRHL Setting	18	32	205	204.8	Yes	Yes
		9	ARHL Setting	18	32	200	199.4	Yes	Yes
		10	HWG Minimum User Setpoint	19	32	185	60	No	Yes
		11	HWG Maximum User Setpoint	19	32	185	185	No	Yes
		12	HWG Boiler Setpoint	19	32	185	180	No	Yes
		13	HWG Boiler Offset	19	0	36	9.9	No	Yes
		14	HWG Boiler Differential	19	0	72	185	No	Yes
OUTDOOR RESET	C	1	SH Setpoint at Low Outdoor Temp.	19	32	185	180	Yes	Yes
		2	SH Setpoint at High Outdoor Temp	19	32	185	68	Yes	Yes
		3	Low Outdoor Temperature	19	-22	86	23	Yes	Yes
		4	High Outdoor Temperature	19	-22	86	86	Yes	Yes
		5	Outdoor Air Shutdown	19	32	122	79.7	No	Yes
		6	OA Shutdown Differential	20	32	122	79.7	No	Yes



# 1 Service

## Parameter table

**Table 1B** (continued from previous page) This table lists SMART TOUCH control module parameters and where to access them

Menu	Sub Item	Parameter Name (as shown on the LCD screen)	See Page	Min	Max	Default	User	Installer	
				Value	Value	Value	Access	Access	
OUTDOOR RESET	C	7	Boost Time	20	0	250	20	No	Yes
		8	Boost Temperature	20	0	25	0	No	Yes
		9	Shift OA Reset Curve	20	-27	27	0	No	Yes
RAMP DELAY	D	1	Ramp Delay Mode	20	N/A	N/A	N/A	No	Yes
		2	Ramp Delay Time #1	20	1	40	2	No	Yes
		3	Ramp Delay Time #2	20	1	40	2	No	Yes
		4	Ramp Delay Time #3	20	1	40	2	No	Yes
		5	Ramp Delay Time #4	20	1	40	1	No	Yes
		6	Ramp Delay Time #5	20	1	40	1	No	Yes
		7	Ramp Delay Time #6	20	1	40	1	No	Yes
		8	Ramp Delay Limit #1	20	10	100	20	No	Yes
		9	Ramp Delay Limit #2	20	10	100	30	No	Yes
		10	Ramp Delay Limit #3	20	10	100	40	No	Yes
		11	Ramp Delay Limit #4	20	10	100	55	No	Yes
		12	Ramp Delay Limit #5	20	10	100	75	No	Yes
		13	Ramp Delay Limit #6	20	10	100	100	No	Yes
BMS	E	1	BMS Active/Inactive	21	ACTIVE	INACTIVE	INACTIVE	No	Yes
		2	BMS Mode	21	POWER	SETPOINT	POWER	No	Yes
		3	BMS Volts at Min Rate	21	0	10	2	No	Yes
		4	BMS Volts at Max Rate	21	0	10	10	No	Yes
		5	BMS Rate at Min Volts	21	4	100	4	No	Yes
		6	BMS Rate at Max Volts	21	0	100	100	No	Yes
		7	BMS Volts at Min Setpoint	21	0	10	2	No	Yes
		8	BMS Volts at Max Setpoint	21	0	10	10	No	Yes
		9	BMS Setpoint at Min Volts	21	32	185	68.9	No	Yes
		10	BMS Setpoint at Max Volts	21	32	185	178.7	No	Yes
		11	BMS Volts to Enable	21	0	10	2	No	Yes
		12	Differential to Stop BMS Demand	21	0	10	0.5	No	Yes
		13	BMS Enable Mode	21	ENABLE	VOLTAGE	VOLTAGE	No	Yes

# 1 Service *(continued)*

## Parameter table

**Table 1B** (continued from previous page) This table lists SMART TOUCH control module parameters and where to access them

Menu	Sub Item	Parameter Name (as shown on the LCD screen)	See Page	Min	Max	Default	User	Installer	
				Value	Value	Value	Access	Access	
ADVANCED SETUP	F	1	Temperature Units	21	°F	°C	°F	Yes	Yes
		2	LCD Backlight Time	21	0	255	240	Yes	Yes
		3	Freeze Protection; Pump On	21	-22	45	44.6	No	Yes
		4	Freeze Protection; Burner On	22	-22	45	37.4	No	Yes
		5	Freeze Protection; Burner Diff	22	0	20	5	No	Yes
		6	HWG to SH Switching Time	22	0	240	30	No	Yes
		7	SH to HWG Switching Time	22	0	240	30	No	Yes
		8	Anti-Cycling Time	22	0	40	10	No	Yes
		9	Anti-Cycling Differential	22	0	40	1	No	Yes
		10	HWG Rate Limiting	22	10	100	100	No	Yes
		11	Service Mode Timeout	22	0	40	40	No	Yes
		12	Controlling Sensor	22	0	4	2	No	Yes
		13	Inlet Control Time Delay	22	0	40	3	No	Yes
SH NIGHT SETBACK	G	1	SH Night Setback Offset Temp	22	0	90	0	No	Yes
		2	SH Night Setback Mon End	22	N/A	N/A	N/A	No	Yes
		3	SH Night Setback Mon Begin	22	N/A	N/A	N/A	No	Yes
		4	SH Night Setback Tue End	22	N/A	N/A	N/A	No	Yes
		5	SH Night Setback Tue Begin	22	N/A	N/A	N/A	No	Yes
		6	SH Night Setback Wed End	22	N/A	N/A	N/A	No	Yes
		7	SH Night Setback Wed Begin	22	N/A	N/A	N/A	No	Yes
		8	SH Night Setback Thur End	22	N/A	N/A	N/A	No	Yes
		9	SH Night Setback Thur Begin	22	N/A	N/A	N/A	No	Yes
		10	SH Night Setback Fri End	22	N/A	N/A	N/A	No	Yes
		11	SH Night Setback Fri Begin	22	N/A	N/A	N/A	No	Yes
		12	SH Night Setback Sat End	22	N/A	N/A	N/A	No	Yes
		13	SH Night Setback Sat Begin	22	N/A	N/A	N/A	No	Yes
		14	SH Night Setback Sun End	22	N/A	N/A	N/A	No	Yes
		15	SH Night Setback Sun Begin	22	N/A	N/A	N/A	No	Yes



# 1 Service

## Parameter table

**Table 1B** (continued from previous page) This table lists SMART TOUCH control module parameters and where to access them

Menu	Sub Item	Parameter Name (as shown on the LCD screen)	See Page	Min	Max	Default	User	Installer	
				Value	Value	Value	Access	Access	
HWG NIGHT SETBACK	H	1	HWG Night Setback Offset Temp	22	0	90	0	No	Yes
		2	HWG Night Setback Mon End	22	N/A	N/A	N/A	No	Yes
		3	HWG Night Setback Mon Begin	22	N/A	N/A	N/A	No	Yes
		4	HWG Night Setback Tue End	22	N/A	N/A	N/A	No	Yes
		5	HWG Night Setback Tue Begin	22	N/A	N/A	N/A	No	Yes
		6	HWG Night Setback Wed End	22	N/A	N/A	N/A	No	Yes
		7	HWG Night Setback Wed Begin	22	N/A	N/A	N/A	No	Yes
		8	HWG Night Setback Thur End	22	N/A	N/A	N/A	No	Yes
		9	HWG Night Setback Thur Begin	22	N/A	N/A	N/A	No	Yes
		10	HWG Night Setback Fri End	22	N/A	N/A	N/A	No	Yes
		11	HWG Night Setback Fri Begin	22	N/A	N/A	N/A	No	Yes
		12	HWG Night Setback Sat End	22	N/A	N/A	N/A	No	Yes
		13	HWG Night Setback Sat Begin	22	N/A	N/A	N/A	No	Yes
		14	HWG Night Setback Sun End	22	N/A	N/A	N/A	No	Yes
		15	HWG Night Setback Sun Begin	22	N/A	N/A	N/A	No	Yes
MOD BUS	I	1	ModBus Active / Inactive	23	ACTIVE	INACTIVE	INACTIVE	No	Yes
		2	ModBus Out of Order Timer	23	5	120	30	No	Yes
CASCADE	J	1	Cascade Active / Inactive	23	ACTIVE	INACTIVE	INACTIVE	No	Yes
		2	Cascade Address	23	0	7	1	No	Yes
		3	Cascade Offset	23	0	40	10	No	Yes
		4	Cascade Differential	23	0	72	20	No	Yes
		5	Max Boiler Setpoint for Cascade	23	32	185	185	No	Yes
		6	Cascade Type	23	N/A	N/A	N/A	No	Yes
		7	Block Time Switching Boiler On / Off	23	0	255	60	No	Yes
		8	Minimum Next On Time	24	0	255	60	No	Yes
		9	Rate % to Switch On Next Boiler	24	1	100	80	No	Yes
		10	Rate % to Switch Off Last Boiler	24	1	100	10	No	Yes
		11	Number of Boiler Pumps Always On	24	0	8	0	No	Yes

# 1 Service *(continued)*

## Parameter table

**Table 1B** (continued from previous page) This table lists SMART TOUCH control module parameters and where to access them

Menu	Sub Item	Parameter Name (as shown on the LCD screen)	See Page	Min	Max	Default	User	Installer	
				Value	Value	Value	Access	Access	
PUMPS	K	1	Boiler Pump Delay	24	0.5	2400	30	No	Yes
		2	Boiler Pump Anti-Seize Time	24	0	40	0.33	No	Yes
		3	Boiler Pump Mode	24	N/A	N/A	N/A	No	Yes
		4	System Pump Mode	24	N/A	N/A	N/A	No	Yes
		5	System Pump Delay	24	0.5	2400	30	No	Yes
		6	System Pump Anti-Seize Time	24	0	40	0.33	No	Yes
		7	HWG Pump Delay	24	0.5	2400	30	No	Yes
		8	HWG Pump Anti-Seize Time	24	0	40	0.33	No	Yes
		9	Delta T Setpoint	24	0	60	0	No	Yes
SERVICE NOTIFICATION	L	1	Maintenance Notice - Months	25	0	36	12	No	Yes
		2	Maintenance Notice - Running Hours	25	0	100,000	10,000	No	Yes
		3	Maintenance Notice - Cycles	25	0	100,000	10,000	No	Yes
		4	Service Contact Number	25	N/A	N/A	N/A	No	Yes
		5	Service Contact Name	25	N/A	N/A	N/A	No	Yes

# 1 Service

## Viewable and changeable control parameters

**NOTICE**

See Table 1B on pages 13 - 17 of this manual for parameter references listed in this section. The parameter references listed in this section will not appear on the LCD screen.

**CAUTION**

Before changing parameters, note the settings so that the unit can be returned to its original operating parameters.

### A: Initial Setup

#### Clock and Date

The control uses an internal clock for the night setback feature and for logging of events. For these features to work correctly, the clock must be set when the boiler is first installed or anytime the boiler has been powered off for more than four (4) hours. This parameter must be accessed to set the clock. Parameter **A2** sets the date.

**NOTICE**

The internal clock does not adjust for Daylight Savings Time and therefore, will require a manual adjustment.

Parameters **A3** - **A12** shown in the Initial Setup Menu are grouped here for convenience. For a detailed explanation of each parameter, reference the specific menu for each parameter.

### B: Set Points

#### Space Heating (SH) Minimum Set Point

The SH minimum set point sets the minimum water temperature set point that can be used for space heating operation. The user or installer will not be able to program the control with a lower SH set point. This parameter can only be changed by the installer by accessing parameter **B1**.

#### Space Heating (SH) Maximum Set Point

The SH maximum set point sets the maximum water temperature set point that can be used for space heating. The user or installer will not be able to program the control with a higher SH set point. This parameter can only be changed by the installer by accessing parameter **B2**.

#### Space Heating (SH) Set Point

The SH set point sets the water temperature set point used during space heating calls. This parameter can be changed by the installer by accessing parameter **B3**.

#### SH Offset

The SH offset sets how many degrees above set point the temperature can go before the boiler will shut off. This parameter can only be changed by the installer by accessing parameter **B4**.

#### SH Differential

The SH differential sets how many degrees below the offset the temperature has to drop before the boiler turns back on. This parameter can only be changed by the installer by accessing parameter **B5**.

#### HWG Tank Set Point

By installing a tank sensor, the SMART TOUCH control can perform the tank thermostat function. The SMART TOUCH control automatically detects the presence of this sensor, and generates a call for heat when the tank temperature drops below the tank set point minus the differential (parameter **B7**), and finishes the call for heat when the tank temperature reaches tank set point. This parameter can be changed by the installer by accessing parameter **B6**.

#### HWG Tank Differential

When a tank sensor is installed, the tank temperature must drop this amount below the tank set point (parameter **B6**) before the boiler will turn on. The installer can adjust this setting by accessing the parameter **B7**.

#### Manual Reset High Limit

The SMART TOUCH control contains an integral Manual Reset High Limit (MRHL) on the outlet of the heat exchanger. Once the outlet temperature exceeds the MRHL set point, the boiler will shut down and lock out. Once the outlet temperature has dropped below this set point, the RESET button on the LCD display must be pressed to clear this lockout. This set point can be adjusted by accessing parameter **B8**.

#### Auto Reset High Limit

The SMART TOUCH control contains an integral Auto Reset High Limit (ARHL) on the outlet of the heat exchanger. Once the outlet temperature exceeds the ARHL set point, the boiler will shut down and lock out. Once the outlet temperature has dropped below this set point, the RESET button on the LCD display can be pressed to reset this lockout. If RESET is not pressed, the control will automatically reset the lockout after five (5) minutes. This set point can be adjusted by accessing parameter **B9**.

# 1 Service *(continued)*

## HWG Minimum User Set Point

This setting controls the minimum user set point for the tank temperature. The installer can adjust this by accessing parameter **B10**.

## HWG Maximum User Set Point

This setting controls the maximum user set point for the tank temperature. The installer can adjust this by accessing parameter **B11**.

## HWG Boiler Set Point

When a HWG call for heat becomes active, the control will use the HWG boiler set point to determine the firing rate of the boiler based on the boiler outlet water temperature.

This parameter can be changed by the installer by accessing parameter **B12**.

## HWG Boiler Offset

This parameter reflects the degrees above HWG boiler set point the outlet temperature can go before the boiler will shut off. This parameter can be changed by the installer by accessing parameter **B13**.

## HWG Boiler Differential

This parameter reflects the degrees below HWG boiler offset the outlet temperature has to go before the boiler turns on. This parameter can be changed by the installer by accessing parameter **B14**.

## C: Outdoor Reset

### SH Set Point at Low Outdoor Temperature

When the outdoor air temperature drops to or below the Low Outdoor Temperature setting (parameter **C3**), the water temperature will be at this setting (see FIG. 1-6). However, if the user set point is set lower, the water temperature will be limited by the user set point instead. This parameter can be changed by accessing parameter **C1**.

### SH Set Point at High Outdoor Temperature

When the outdoor air temperature rises to or above the High Outdoor Temperature setting (parameter **C4**), the water temperature will be at this setting (see FIG. 1-6). This parameter can be changed by accessing parameter **C2**.

### Low Outdoor Temperature

When the outdoor air temperature drops to its minimum (**C3**), the water temperature will be at parameter **C1** (FIG. 1-6). As the outdoor temperature continues to drop, the water temperature set point will continue to rise. However, if the user set point is set lower, the water temperature will be limited by the user set point instead. This parameter can be changed by accessing parameter **C3**.

### High Outdoor Temperature

When the outdoor air temperature rises to or above this set point, the water temperature will be at parameter **C2** (FIG. 1-6). This parameter can be changed by the installer by accessing parameter **C4**.

### Outdoor Air Shutdown

When the outdoor temperature rises above this point, the control will block all SH demands (HWG demands will still be active). This parameter can be changed by the installer by accessing parameter **C5**.

**Figure 1-6 Outdoor Air Reset Curve**

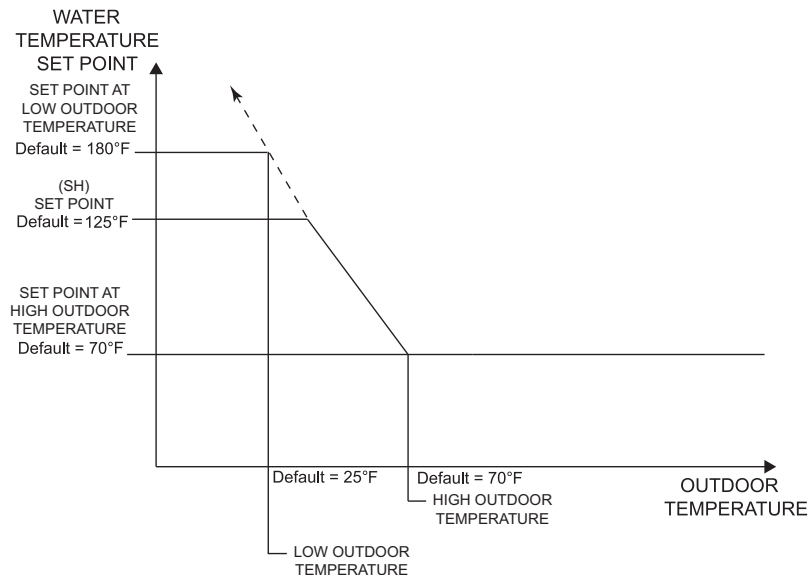

# 1 Service

## Outdoor Air Shutdown Differential

The outdoor air shutdown differential parameter is the number of degrees below parameter C5 the outdoor air temperature must go before the boiler will respond to a SH demand. This parameter can be changed by the installer by accessing parameter C6.

## Boost Time

The boost time parameter sets the amount of time that must elapse with a SH demand before the water temperature calculated set point will be increased. This parameter can be changed by the installer by accessing parameter C7.

## Boost Temperature

If a SH demand lasts longer than the programmed boost time delay setting (C7) and there have been no HWG demands, the control will increase the water temperature set point by the amount in this parameter. If the SH demand continues through another time period, the set point will be increased again. This will continue until either the SH demand ends, a maximum of 20 increases has occurred, or the maximum set point has been reached. Once the SH demand has been satisfied the set point will revert back to its calculated setting. The boost temperature can be changed by the installer by accessing parameter C8.

## Shift OA Reset Curve

The shift reset curve parameter shifts the actual set point above or below the calculated set point by the number of degrees in this parameter. This parameter can be changed by the installer by accessing parameter C9.

D: Ramp Delay

## Ramp Delay (Enable / Disable)

This parameter allows the installer to enable or disable the SH ramp delay by accessing parameter D1.

## SH Ramp Delay

The SMART TOUCH control can be programmed to limit the firing rate for a fixed period of time at the start of a space heating demand. There are six (6) possible limits, each with their own time delay. The first limit applies as soon as the burner starts. Once its time delay expires, the second limit is applied and its timer begins. The control steps through these limits until the 6th (sixth) limit expires. Note, however, that the 6th limit will also limit the rate for the rest of that heat demand. The installer can adjust the firing limits and time delays by accessing parameters D2 through D13.

Figure 1-7 Ramp Delay Interval

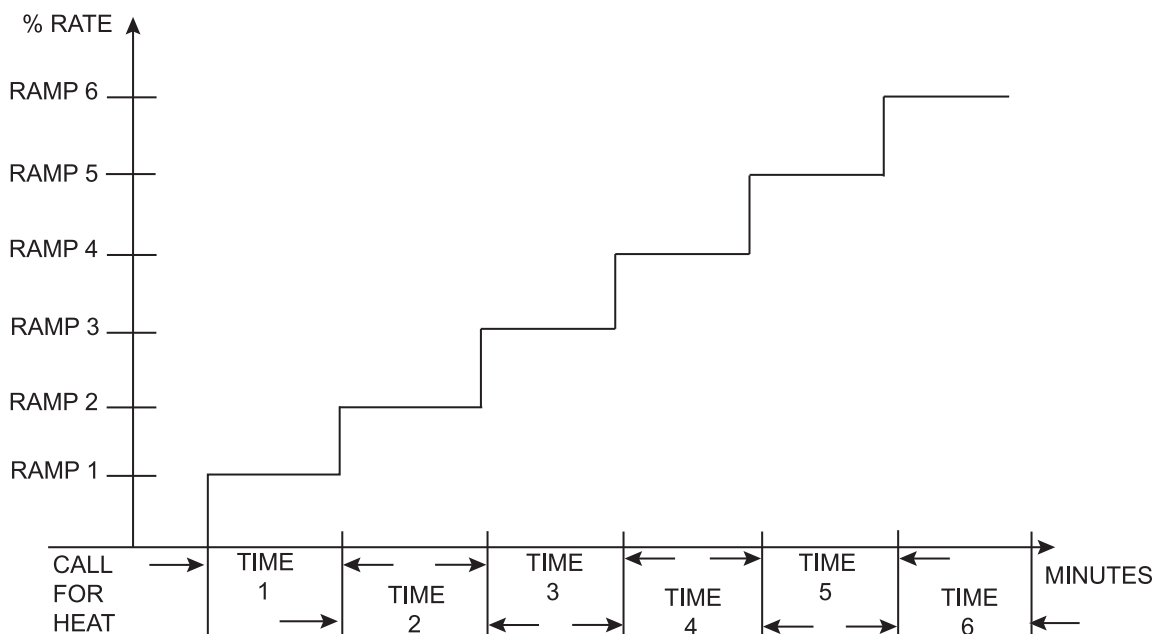

# 1 Service *(continued)*

## E: BMS

### **BMS (Active / Inactive)**

The set point or modulation of the boiler may be controlled through the 0 - 10V BMS input or through ModBus. When parameter **E1** set to INACTIVE, the 0 - 10V input will be ignored. When set to ACTIVE, the set point or modulation will be controlled by the voltage on the 0 - 10V input (in the case of 0 - 10V BMS control), or the 0 - 10V input value received through ModBus.

### **BMS Mode (Power / Set Point)**

When programmed for BMS control through the 0 - 10V BMS input or through ModBus, the 0 - 10V signal can be interpreted as either a modulation command or a set point. When parameter **E2** is set to POWER, the 0 - 10V signal will control the modulation. When set to SETPOINT, the 0 - 10V signal will control the SH set point.

### **BMS Volts at Minimum (Rate or Set Point)**

When programmed for BMS control through the 0 - 10V BMS input or through ModBus, parameters **E3** or **E7** should be set to the minimum voltage signal sent to the SMART TOUCH control.

### **BMS Volts at Maximum (Rate or Set Point)**

When programmed for BMS control through the 0 - 10V BMS input or through ModBus, parameter **E4** or **E8** should be set to the maximum voltage signal sent to the SMART TOUCH control.

### **BMS Rate at Minimum Volts**

When programmed for BMS control through the 0 - 10V BMS input or through ModBus and the BMS Type is programmed as POWER, the modulation percentage represented by the Volts at Minimum parameter (**E3**) is set by parameter **E5**.

### **BMS Rate at Maximum Volts**

When programmed for BMS control through the 0 - 10V BMS input or through ModBus and the BMS Type is programmed as POWER, the modulation percentage represented by the Volts at Maximum parameter (**E4**) is set by parameter **E6**.

### **BMS Set Point at Minimum Volts**

When programmed for BMS control through the 0 - 10V BMS input or through ModBus and the BMS Type is programmed as SETPOINT, the set point represented by the Volts at Minimum parameter (**E7**) is set by parameter **E9**.

### **BMS Set Point at Maximum Volts**

When programmed for BMS control through the 0 - 10V BMS input or through ModBus and the BMS Type is programmed as SETPOINT, the set point represented by the Volts at Maximum parameter (**E8**) is set by parameter **E10**.

### **BMS Volts to Enable**

When programmed for BMS control through the 0 - 10V BMS input or through ModBus and the BMS Enable Mode is set to INACTIVE, parameter **E11** determines the 0 - 10V BMS input voltage at which the boiler is enabled.

### **Differential to Stop BMS Demand**

When programmed for BMS control through the 0 - 10V BMS input or through ModBus and the BMS Enable Mode is set to INACTIVE, parameter **E12** determines how far below the On Volts setting **E11** the 0 - 10V BMS input voltage must be in order to disable the boiler.

### **BMS Enable Mode**

When controlling the boiler through the 0 - 10V BMS input or through ModBus, the boiler can be enabled one of two ways. With parameter **E13** set to ACTIVE, the boiler will be enabled by closing the Enable input. When parameter **E13** is set to INACTIVE, the boiler will be enabled by the voltage level on the 0 - 10V input (in the case of 0 - 10V BMS control), or the 0 - 10V input value received through ModBus.

## F: Advanced Setup

### **Temperature units (°C / °F)**

The control can be configured to display temperature in either °C or °F. This parameter can be changed by the user or the installer by accessing parameter **F1**.

### **Display Timeout (LCD Backlight Time)**

This is the time in which the display remains illuminated. This parameter can be changed by the user or the installer by accessing parameter **F2**.

### **Freeze Protection Pump On**

The SMART TOUCH control will turn on the boiler and system pump outputs whenever the inlet temperature drops below this setting. This is done to prevent the water in the heat exchanger from freezing. Certain low-temperature applications (such as snow melt) can operate at temperatures around freezing, so this setting needs to be lowered in these cases. The installer can adjust the temperature at which the pump outputs are turned on by accessing parameter **F3**.



# 1 Service

## Freeze Protection Burner On

If running the pumps does not prevent the inlet temperature from falling closer to freezing, the SMART TOUCH control will fire the burner at low fire if in the ON state. The installer can adjust the temperature at which the burner fires by adjusting parameter **F4**.

## Freeze Protection Burner Differential

Once the burner has started firing due to a low inlet temperature, the inlet temperature must increase by this amount before the burner turns back off. The installer can adjust this differential by accessing parameter **F5**.

## HWG/SH Switching Time

When a boiler has a HWG demand and it receives a space heating demand, the SMART TOUCH control will start a timer. Once the timer expires, it will stop the HWG demand and service the space heating demand. The installer can adjust the length of time the boiler will service the HWG demand by accessing parameter **F6**.

## SH/HWG Switching Time

When a boiler has a space heating demand and it receives a HWG demand, it will immediately switch to the HWG demand and start a timer. Once the timer has expired, the boiler will switch back to the space heating demand and start another timer. Once this timer expires, it will switch back to the HWG demand. The installer can adjust the length of time the boiler will service the space heating demand by accessing parameter **F7**.

## Anti-Cycling Time

Once a SH demand has been satisfied, a set amount of time must elapse before the control will respond to a new SH demand. The control will block the new heat demand and anti-cycling will be shown in the display until the time has elapsed or the water temperature drops below parameter **F9**. This parameter can be changed by the installer by accessing parameter **F8**.

## Anti-Cycling Differential

The control will bypass the anti-cycling time if the inlet water temperature drops too much. The control will use the inlet water temperature at the time the boiler shut off as the starting point. If the inlet temperature drops below this temperature parameter the control will abort anti-cycling and allow the boiler to fire. This parameter can be changed by the installer by accessing parameter **F9**.

## HWG Rate Liming (NOT AVAILABLE AT THIS TIME)

This parameter determines the maximum rate to be used when heating a HWG tank. This setting may be used when the tank is unable to accept all of the BTU's available from the boiler. This parameter may be adjusted by the installer by accessing parameter **F10**.

## Service Mode Timeout

The Service Mode allows the installer to set the unit to any firing rate for the purpose of combustion analysis. The delay sets the length of time the boiler will stay in the Service Mode if no keys have been pressed before going back to its original state. This parameter can only be changed by the installer by accessing parameter **F11**.

## Controlling Sensor

The SH controlling sensor parameter selects the sensor the control will use to regulate the boiler firing rate. This parameter is adjustable by the installer by accessing parameter **F12**. The sensor selections are as follows: The outlet sensor regulates the firing rate based on the outlet water temperature of the boiler and the inlet sensor regulates the firing rate based on the inlet water temperature of the boiler. If the outlet sensor is selected, and the optional system supply sensor is connected, the control will regulate the firing rate based on the system supply sensor temperature.

## Inlet Control Time Delay

When the inlet sensor is selected as the controlling sensor, the SMART TOUCH control will start by controlling the outlet/system supply temperature to the SH set point. After a time delay, the control will start to increase and regulate the system supply temperature in order to maintain the inlet/system return temperature to the SH set point. This time delay should be long enough for the heated water to work its way through the system loop and be measured by the inlet/system return sensor. This time delay is adjustable by the installer by accessing parameter **F13**.

## G/H: SH/HWG Night Setback

The installer may adjust the space heating night setback offset by accessing parameter **G1** and the HWG night setback offset by accessing parameter **H1**.

Once the internal clock has been set correctly, the SH night setback feature can be used to program a lower set point. The value of this parameter will be subtracted from the normal set point to determine the set point used during night setback. This parameter can be changed by the user or the installer by accessing parameters **G2** through **G15** and **H2** through **H15**. The temperature range for this parameter is 0°F to 90°F (50°C). The feature is turned off with a setting of 0°F.



# 1 Service *(continued)*

## I: ModBus

### ModBus (Active / Inactive)

When BMS is set to ACTIVE (see BMS Active / Inactive) and the boiler is being controlled through ModBus, set parameter **I1** to ACTIVE. Otherwise, set the ModBus parameter to INACTIVE. Note that the boiler can still be monitored by ModBus with this parameter set to INACTIVE.

### ModBus Out of Order Timer

When the boiler is being provided with certain commands and temperatures through ModBus, this information must be updated frequently. If it is not updated before this timer expires, the boiler will revert back to its own internal readings and control. This parameter is adjustable by the installer by accessing parameter **I2**.

## J: Cascade

### Cascade Active / Inactive

The boiler is part of a group of units sequenced together. The designated Leader unit determines the total output needed from the group based on the set point and controlling sensor reading. It assigns portions of the output to itself (Leader) and the Member units. When Cascade is active, each boiler in the group requires a unique address. This setting is adjustable by the installer by accessing parameter **J1**.

### Cascade Address

The boiler designated as the Leader needs to be programmed with address 0. All the Member boilers require addresses from 1 to 7, and the addresses must be different for each Member. The addresses can be in any order, regardless of the order in which the units are wired together. This parameter is adjustable by the installer by accessing parameter **J2**. The outdoor air (if used) and system supply sensor must be connected to the Leader boiler.

### Cascade Offset

This parameter determines how much the temperature can go above set point before the lead boiler will turn off. This parameter can be adjusted by the installer by accessing parameter **J3**.

### Cascade Off-On Differential

This parameter determines how much the temperature must go below the turn off temperature (Set point + Offset) before the lead boiler turns on. This parameter can be adjusted by the installer by accessing parameter **J4**.

### Maximum Boiler Set Point for Cascade

This parameter determines the set point used by the individual boilers in a Cascade. When a boiler is commanded to fire by the Leader boiler, it will attempt to achieve this temperature at its outlet. If any of the boiler outlet temperatures reach the maximum cascade set point, the boiler will then modulate down on its own in order to keep its outlet temperature within the maximum cascade set point. Therefore, this parameter can be used to limit the outlet temperatures of all the boilers in a Cascade. Note that this parameter does not apply when the boiler is heating an indirect HWG tank. This parameter is adjustable by the installer by accessing parameter **J5**.

### Cascade Type

The Cascade divider method is Efficiency Optimization, designated as EFF in the menu. This method is used, as the name implies, when it is desired to have the most efficient system. When the first boiler reaches a certain rate (default = 80%), it lowers its rate to 40% and turns on the next boiler at 40%. The two (2) boilers then modulate at the same rate. As the calculated load increases further and both boilers ramp up to 80%, it lowers the rate of the first two (2) boilers to 53% and brings the next boiler on at 53%. The three (3) boilers then modulate together. As the calculated load decreases, the boilers will reach a lower threshold (default = 10%), at which time the last boiler (the third in our example) will turn off and the Cascade will increase the rates of the remaining boilers to provide the equivalent total output as before ( $(3 \times 10\%) / 2 = 15\%$  in our example). This parameter can be adjusted by the installer by accessing parameter **J6**.

### Minimum On/Off Time

In order to prevent units in a Cascade from short cycling, this parameter defines the minimum ON and OFF time for each unit. The installer can adjust this time by accessing parameter **J7**.

# 1 Service

## Minimum Next On Time

In order to reduce the risk of temperature overshoot with a Cascade, this parameter defines the minimum time delay from starting one unit until the next unit may be started. The installer can adjust this time delay by accessing parameter **J8**.

## Rate % to Switch on Next Boiler

When the Cascade is programmed in the Efficiency Optimization Mode, the currently running boilers must ramp up to a certain firing rate before the next boiler in the Cascade will start. This percentage can be adjusted by accessing parameter **J9**.

## Rate % to Switch off Last Boiler

When the Cascade is programmed in the Efficiency Optimization Mode, the currently running boiler will stop. This percentage can be adjusted by accessing parameter **J10**.

## Number of Boiler Pumps Always On

When multiple Crest boilers are connected in a Cascade, the SMART TOUCH control can keep a minimum number of the boiler pumps running, regardless of how many of the boilers are firing. This is useful in full flow systems where the system flow is provided by the individual boiler pumps. This number can be adjusted by accessing parameter **J11**.

K: Pumps

## Boiler Pump Delay

The SH pump delay parameter sets the length of time the boiler pump will run after a SH demand has been satisfied. This parameter is adjustable by the installer by accessing parameter **K1**.

## Boiler Pump Anti-Seize Time

If the boiler pump does not run for 24 hours, it will be turned on briefly to prevent it from seizing. The length of time it runs is determined by parameter **K2**.

## Boiler Pump Mode

The SMART TOUCH control is able to control the boiler pump in 3 different ways. The options are as follows:

1. ON with a call for heat, with a constant speed.
2. ON with a call for heat, with a variable speed output.
3. Always OFF (not connected).

The Boiler Pump Mode can be adjusted by accessing parameter **K3**.

## System Pump Mode

The SMART TOUCH control is able to control the system pump in 5 different ways. The options are as follows:

1. ON with a call for heat, with a constant speed.
2. ON with a call for heat, with a variable speed input.
3. Always ON, with a constant speed, except during outdoor shutdown.
4. Always ON, with a variable speed input, except during outdoor shutdown.
5. Always OFF (not connected).

For options 2 and 4, the speed of the system pump is controlled by a separate control system. The System Pump Mode can be adjusted by accessing parameter **K4**.

## System Pump Delay

The system pump delay parameter sets the length of time the system pump (if connected) will run after a SH demand has been satisfied. This parameter is adjustable by the installer by accessing parameter **K5**.

## System Pump Anti-Seize Delay

If the boiler pump does not run for 24 hours, it will be turned on briefly to prevent it from seizing. The length of time it runs is determined by parameter **K6**.

## HWG Pump Delay

The HWG pump delay parameter sets the length of time the HWG pump (if connected) will run after a HWG demand has been satisfied. This parameter is adjustable by the installer by accessing parameter **K7**.

## HWG Pump Anti-Seize Delay

If the boiler pump does not run for 24 hours, it will be turned on briefly to prevent it from seizing. The length of time it runs is determined by parameter **K8**.

## $\Delta T$ Set Point

The SMART TOUCH control includes a 0 - 10Vdc output for controlling the speed of a variable speed boiler pump. The speed is regulated in order to, among other things, maintain a minimum delta T across the heat exchanger. This helps reduce the electrical consumption of the boiler pump when the boiler is firing at less than its maximum rate. (This feature is active only when a system supply sensor is installed). This set point can be adjusted by accessing parameter **K9**.

# 1 Service *(continued)*

## L: Service Notification

### **Service Notification in Months**

When the boiler control determines that a scheduled service is due based on the months of installation, the boiler display will turn yellow and a new status screen will appear informing the installer that maintenance is required. This parameter is adjustable by the installer by accessing parameter **L1**.

### **Service Notification Running Hours**

When the boiler control determines that a scheduled service is due based on the hours of actual operation, the boiler display will turn yellow and a new status screen will appear informing the installer that maintenance is required. This parameter is adjustable by the installer by accessing parameter **L2**.

### **Service Notification Cycles**

When the boiler control determines that a scheduled service is due based on the number of boiler cycles, the boiler display will turn yellow and a new status screen will appear informing the installer that maintenance is required. This parameter is adjustable by the installer by accessing parameter **L3**.

### **Installer Name and Phone Number**

When a Maintenance Reminder timer or counter has expired, a Maintenance Reminder screen will appear on the display. By programming the installer's name and phone number, this information will appear on the Maintenance Reminder Screen at that time. This can be programmed by accessing parameters **L4 and L5**. When selected, another menu will appear with PHONE and NAME.

# 1 Service

## Cascade Screen

Figure 1-8 Cascade Screen



The Cascade Screen provides the status of the Cascade System. This screen is only accessible when the boiler is the Leader of an active Cascade. There are many items displayed on the Cascade Screen. Among them is the Boiler Power Level Indicators. For each boiler present in the Cascade a power level indicator will be present above its corresponding Cascade address. The level of the indicator will rise and fall indicating the approximate power level of the boiler. The display box above each power level will display the following:

- “ 100%” – A percentage indicates that firing rate of the corresponding boiler.
- “ \_\_\_\_” – A blank field indicates that the corresponding boiler has lost communication.
- “Error” – Error indicates that the corresponding boiler is in Lockout.
- “Off” – Off indicates that the corresponding boiler is turned off.
- “HWG” – HWG indicates that the corresponding boiler is supplying a hot water generator demand.
- “Frost” – Frost indicates that the corresponding boiler is in frost protection and is not being controlled by the Leader.
- “- - “ – Two dash marks indicate that there is not a demand for the corresponding boiler.

# 1 Service *(continued)*

## Graph Screen

The Graph Screen consists of two (2) different screens. The First screen is the Parameter Selection Screen. By pressing the up and down arrow keys the desired parameter can be selected. When the SELECT button is pressed the parameter will appear in the bottom half of the first screen. If a parameter is selected by mistake, it can be de-selected by highlighting the parameter and pressing the SELECT button. A maximum of five (5) items can be graphed at one time.

**Figure 1-9** Graph Screen\_Parameter Selection

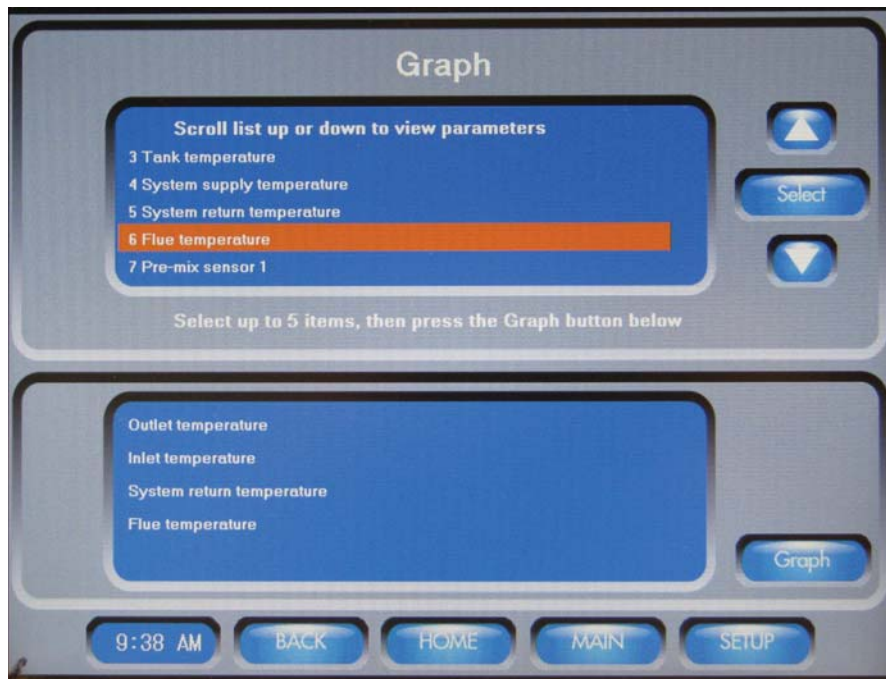

The Second screen is accessed by pressing the GRAPH button. Once the items to be graphed are selected, press the GRAPH button to view the graph. Each item graphed will have a different color line to represent it. The items selected will be shown below the graph along with their corresponding color. Press the BACK button to return to the Parameter Selection Screen.

**Figure 1-10** Graph Screen





# 1 Service History Screen

The History Screen shows the status of various counters and faults. Within the History Screen there are three separate screens. These screens are the “Lockout Faults”, “Blocking Faults” and “Runtime History”.

The default screen is the “Lockout Faults” screen. This screen allows you to view the last ten (10) lockout faults. Preceded by each fault is the date and time of when the fault occurred. The lockout faults can be reset by pressing the RESET FAULTS button.

**Figure 1-11** History Screen\_Lockout Faults



The next screen is the “Blocking Faults” Screen. This screen allows you the view the last ten (10) blocking faults. Preceded by each fault is the date and time of when the fault occurred. The blocking faults can be reset by pressing the RESET FAULTS button.

**Figure 1-12** Graph Screen\_Blocking Faults

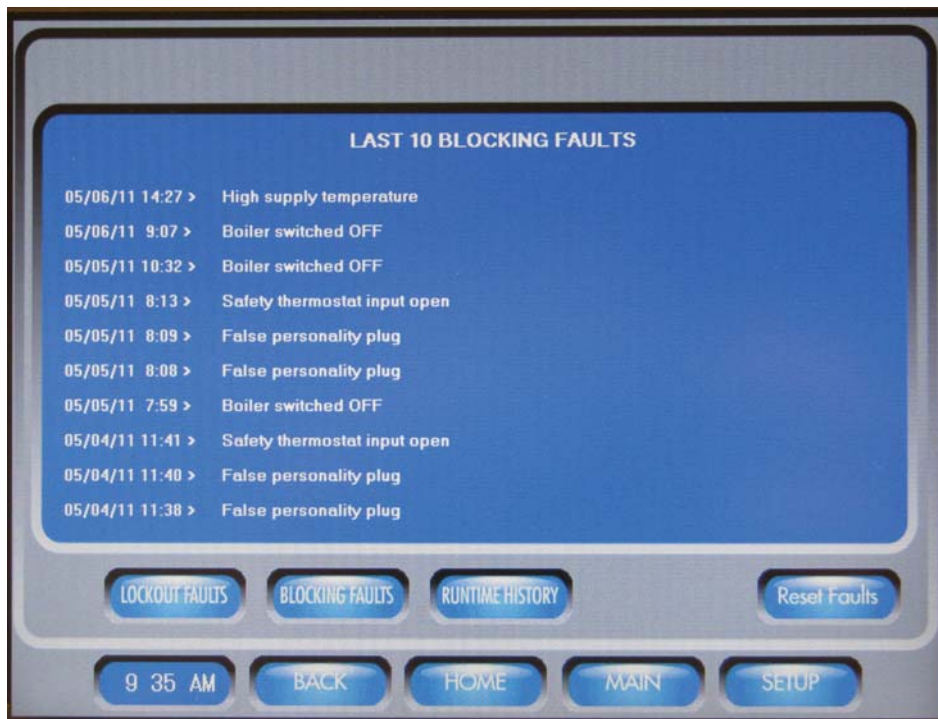

# 1 Service *(continued)*

## History Screen

The third screen is the “Runtime History”. There are several pieces of information that are displayed on this screen. Items that can be viewed on this screen are as follows:

- Power hours – Shows the number of hours the control has been powered on since the last reset.
  - Running hours – Shows the number of hours that the boiler has been firing since the last reset.
  - Ignition attempts – Shows the number of times the control has attempted to ignite since the last reset.
  - Successful Ignition attempts - Shows the number of times the control has successfully ignited since the last reset.
  - Total Power hours – Show the total number of hours the control has been powered.
  - Total Running hours – Show the total number of hours that the boiler has been firing.
  - Total ignition attempts – Show the total number of times the control has attempted to ignite.
  - Total Successful ignition attempts – Show the total number of times the control has successfully ignited.
- The top left of this screen details the running hours based on 4 different running positions.

**Figure 1-13** History Screen\_Runtime History

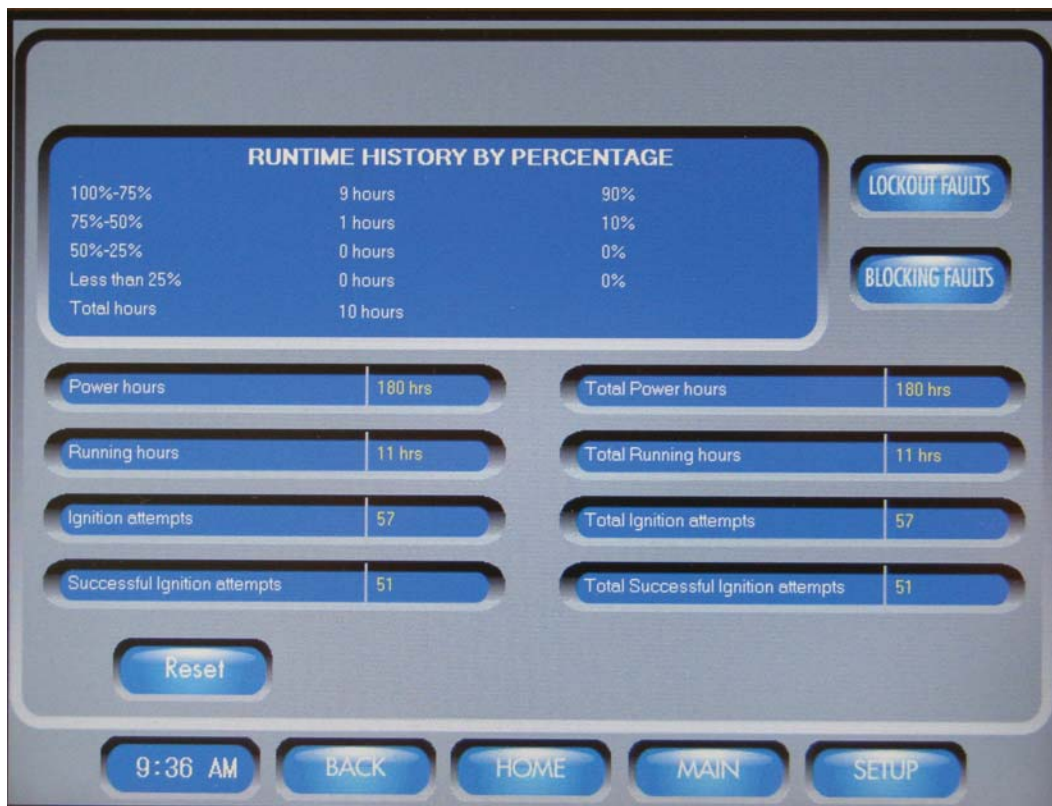



# 1 Service *(continued)*

## Service Screen

The Service Screen allows the integrated control to override all other heat demands and operate Valve 1 and Valve 2 at high fire and low fire conditions. To place the boiler into Service Mode, press the START button. As specified above the integrated control will override all other heat demands, however, all safeties will be active. If no buttons are pressed, the integrated control will automatically revert back to its original status after the “Remaining time in Servicer” counter expires.

Once the boiler has been placed into Service Mode it will light and modulate to low fire. At any time after that point there are two (2) ways to adjust the firing rate. The first way is by pressing one of the six (6) preset buttons. The second way is by manually adjusting the firing percentage using the “+” and “-“ buttons. When Service Mode is no longer needed press the STOP button to return to normal operation.

**Figure 1-14** Service Screen

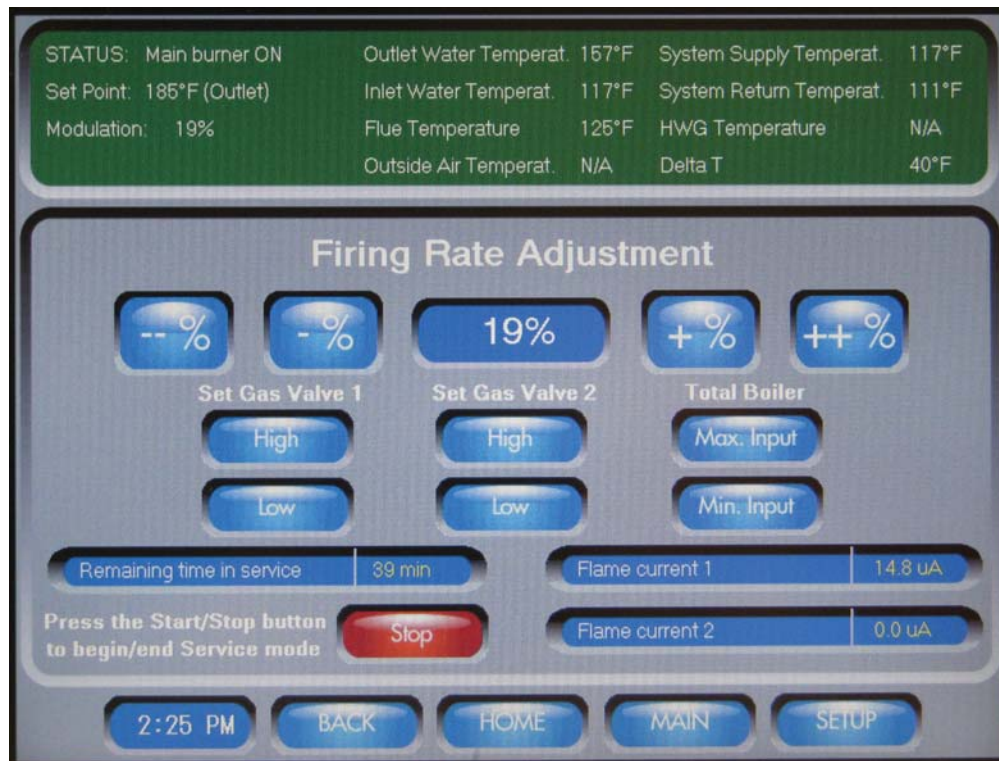

## 2 Maintenance

### Maintenance and annual startup

**Table 2A** Service and Maintenance Schedules

Service technician (see the following pages for instructions)		Owner maintenance (see the Crest User's Information Manual for instructions)	
<b>ANNUAL START-UP</b>	<b>General:</b>	<b>Daily</b>	<ul style="list-style-type: none"> <li>• Check boiler area</li> <li>• Check pressure/temperature gauge</li> </ul>
	<ul style="list-style-type: none"> <li>• Address reported problems, if any</li> <li>• Inspect interior; clean and vacuum if necessary;</li> <li>• Clean condensate trap and fill with fresh water</li> <li>• Check for leaks (water, gas, flue, condensate)</li> <li>• Verify flue and air lines in good condition and sealed tight</li> <li>• Check system water pressure/system piping/expansion tank</li> <li>• Check control settings</li> <li>• Check the ignition and both flame sense electrodes (sand off any deposits; clean and reposition)</li> <li>• Check wiring and connections</li> <li>• Perform start-up checkout and performance verification per Section 9 of the Crest Installation and Operation Manual.</li> <li>• Flame inspection (stable, uniform)</li> <li>• Check both flame signals (at least 10 microamps at high fire)</li> <li>• Test low water cutoff.</li> </ul>	<b>Monthly</b>	<ul style="list-style-type: none"> <li>• Check vent piping</li> <li>• Check air piping</li> <li>• Check air and vent termination screens</li> <li>• Check relief valve</li> <li>• Check condensate drain system</li> </ul>
	<p><b>If combustion or performance indicate need:</b></p> <ul style="list-style-type: none"> <li>• Clean heat exchanger</li> <li>• Remove and clean burner using compressed air only</li> <li>• Clean the blower wheels</li> </ul>	<b>Every 6 months</b>	<ul style="list-style-type: none"> <li>• Test low water cutoff</li> <li>• Reset button (low water cutoff)</li> <li>• Check boiler piping (gas and water) for leaks</li> <li>• Operate relief valve</li> </ul>
		<b>End of season months</b>	<ul style="list-style-type: none"> <li>• Shut boiler down (unless boiler used for domestic hot water)</li> </ul>

## 2 Maintenance

**⚠ WARNING** Follow the service and maintenance procedures given throughout this manual and in component literature shipped with the boiler. Failure to perform the service and maintenance could result in damage to the boiler or system. Failure to follow the directions in this manual and component literature could result in severe personal injury, death, or substantial property damage.

**⚠ WARNING** The boiler should be inspected annually only by a qualified service technician. In addition, the maintenance and care of the boiler designated in Table 2A and explained on the following pages must be performed to assure maximum boiler efficiency and reliability. Failure to service and maintain the boiler and system could result in equipment failure.

**⚠ WARNING** Electrical shock hazard – Turn off power to the boiler before any service operation on the boiler except as noted otherwise in this instruction manual. Failure to turn off electrical power could result in electrical shock, causing severe personal injury or death.

### Address reported problems

1. Inspect any problems reported by the owner and correct before proceeding.

### Inspect boiler area

1. Verify that boiler area is free of any combustible materials, gasoline and other flammable vapors and liquids.
2. Verify that air intake area is free of any of the contaminants listed in Section 1 of this manual. If any of these are present in the boiler intake air vicinity, they must be removed. If they cannot be removed, reinstall the air and vent lines per this manual.

### Inspect boiler interior

1. Remove the front access covers and inspect the interior of the boiler.
2. Vacuum any sediment from inside the boiler and components. Remove any obstructions.

### Clean condensate trap

1. Inspect the condensate drain line, vent line, condensate PVC fittings, and condensate trap.

#### Flush condensate trap with water

1. Remove the four (4) screws securing the top cover to the condensate trap and remove the cover (FIG. 2-1).
2. Locate the plastic ball inside the float tube. Verify there is nothing under the ball causing it to not seat properly.
3. Fill with fresh water until the water begins to pour out of the drain.
4. Replace the top cover and the screws removed in Step 1.

**Figure 2-1** Condensate Trap

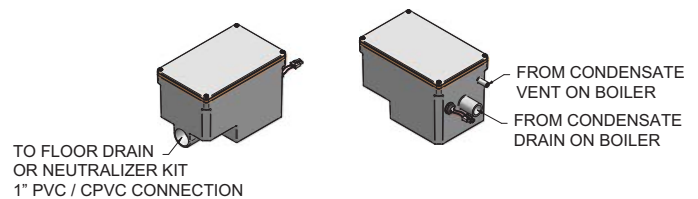

### Check all piping for leaks

**⚠ WARNING** Eliminate all system or boiler leaks. Continual fresh makeup water will reduce boiler life. Minerals can build up, reducing heat transfer, overheating heat exchanger, and causing heat exchanger failure. Leaking water may also cause severe property damage.

1. Inspect all water and gas piping and verify to be leak free.
2. Look for signs of leaking lines and correct any problems found.
3. Check gas line using the procedure found in Section 6 - *Gas Connections of the Crest Installation and Operation Manual*.

## 2 Maintenance *(continued)*

### Flue vent system and air piping

1. Visually inspect the entire flue gas venting system and air piping for blockage, deterioration or leakage. Repair any joints that show signs of leakage. Verify that air inlet pipe is connected and properly sealed.
2. Verify that boiler vent discharge and air intake are clean and free of obstructions.

**⚠ WARNING** Failure to inspect for the above conditions and have them repaired can result in severe personal injury or death.

### Check water system

1. Verify all system components are correctly installed and operational.
2. Check the cold fill pressure for the system. Verify it is correct (must be a minimum of 12 psi (82.7 kPa)).
3. Watch the system pressure as the boiler heats up (during testing) to ensure pressure does not rise too high. Excessive pressure rise indicates expansion tank sizing or performance problem.
4. Inspect automatic air vents and air separators. Remove air vent caps and briefly press push valve to flush vent. Replace caps. Make sure vents do not leak. Replace any leaking vents.

### Check expansion tank

1. Expansion tanks provide space for water to move in and out as the heating system water expands due to temperature increase or contracts as the water cools. Tanks may be open, closed or diaphragm or bladder type. See Section 5 - *Hydronic Piping* of the Crest Installation and Operation Manual for suggested best location of expansion tanks and air eliminators.

### Check boiler relief valve

1. Inspect the relief valve and lift the lever to verify flow. Before operating any relief valve, ensure that it is piped with its discharge in a safe area to avoid severe scald potential. Read Section 5 - *Hydronic Piping* of the Crest Installation and Operation Manual before proceeding further.

**⚠ WARNING**

Safety relief valves should be re-inspected AT LEAST ONCE EVERY THREE YEARS, by a licensed plumbing contractor or authorized inspection agency, to ensure that the product has not been affected by corrosive water conditions and to ensure that the valve and discharge line have not been altered or tampered with illegally. Certain naturally occurring conditions may corrode the valve or its components over time, rendering the valve inoperative. Such conditions are not detectable unless the valve and its components are physically removed and inspected. This inspection must only be conducted by a plumbing contractor or authorized inspection agency – not by the owner. Failure to re-inspect the boiler relief valve as directed could result in unsafe pressure buildup, which can result in severe personal injury, death, or substantial property damage.

**⚠ WARNING**

Following installation, the valve lever must be operated AT LEAST ONCE A YEAR to ensure that waterways are clear. Certain naturally occurring mineral deposits may adhere to the valve, rendering it inoperative. When manually operating the lever, water will discharge and precautions must be taken to avoid contact with hot water and to avoid water damage. Before operating lever, check to see that a discharge line is connected to this valve directing the flow of hot water from the valve to a proper place of disposal. Otherwise severe personal injury may result. If no water flows, valve is inoperative. Shut down the boiler until a new relief valve has been installed.

2. After following the above warning directions, if the relief valve weeps or will not seat properly, replace the relief valve. Ensure that the reason for relief valve weeping is the valve and not over-pressurization of the system due to expansion tank waterlogging or undersizing.

## 2 Maintenance

### Inspect ignition and flame sense electrodes

1. Remove the ignition and both flame sense electrodes from the burner plate.
2. Remove any deposits accumulated on the ignition/flame sense electrodes using sandpaper. If the electrodes cannot be cleaned satisfactorily, replace with new ones.
3. Replace ignition/flame sense electrodes, making sure the gaskets are in good condition and correctly positioned.

### Check ignition ground wiring

1. Inspect boiler ground wire from the heat exchanger access cover to ground terminal strip.
2. Verify all wiring is in good condition and securely attached.
3. Check ground continuity of wiring using continuity meter.
4. Replace ground wires if ground continuity is not satisfactory.

### Check all boiler wiring

1. Inspect all boiler wiring, making sure wires are in good condition and securely attached.

### Check control settings

1. Navigate to the Setup Screen and check all settings. See Section 1 of this manual. Adjust settings if necessary. See Section 1 of this manual for adjustment procedures.
2. Check settings of external limit controls (if any) and adjust if necessary.

### Perform start-up and checks

1. Start boiler and perform checks and tests specified in Section 9 - *Start-up of the Crest Installation and Operation Manual*.
2. Verify cold fill pressure is correct and that operating pressure does not go too high.

### Check burner flame

1. Inspect flame through observation windows.
2. If the flame is unsatisfactory at either high fire or low fire, remove and clean the burner. Clean the burner thoroughly using a vacuum cleaner or compressed air. Do not use compressed air to clean the burner if cleaning is performed inside a building.

- Shut down the boiler:
    - Follow the “To Turn Off Gas to Appliance” instructions for the boiler in Section 9 - Startup of the Crest Installation and Operation Manual.
    - Do not drain the boiler unless it will be exposed to freezing temperatures. If using freeze prevention fluid in system, do not drain.
3. Allow time for the boiler to cool to room temperature if it has been firing.
  4. Remove the top access panel to remove the gas/air manifold assembly.
  5. Remove the nuts securing the burner to the burner mounting plate. Remove the burner (FIG. 2-2).
  6. When replacing the burner, ensure gaskets are in good condition and positioned correctly (FIG. 2-2).
  7. When securing the burner, be sure to tighten the nuts, but DO NOT over-tighten. Tighten the nuts to a torque setting of no more than 6.2 ft.-lbs. When securing the burner mounting plate be sure to tighten the nuts, but DO NOT over-tighten. Tighten the nuts to a torque setting of no more than 15.5 ft.-lbs.

**Figure 2-2 Burner Assembly**

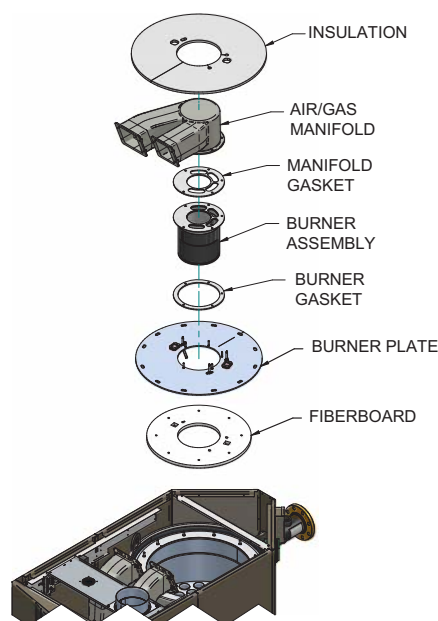

### Check flame signal

1. At high fire of each combustion system, the flame signal shown on the display should be at least 10 microamps.
2. A lower flame signal may indicate a fouled or damaged flame sense electrode. If cleaning the flame sense electrodes does not improve, ground wiring is in good condition, and ground continuity is satisfactory, replace the flame sense electrode.
3. See Section 3 - *Troubleshooting* in this manual for other procedures to deal with low flame signal.



## 2 Maintenance *(continued)*

### Review with owner

1. Review the Crest User's Information Manual with the owner.
2. Emphasize the need to perform the maintenance schedule specified in the Crest User's Information Manual (and in this manual as well).
3. Remind the owner of the need to call a licensed contractor should the boiler or system exhibit any unusual behavior.
4. Remind the owner to follow the proper shutdown procedure and to schedule an annual start-up at the beginning of the next heating season.

### Cleaning boiler heat exchanger

1. Shut down boiler:
  - Follow the "To Turn Off Gas to Appliance" instructions for the boiler in Section 9 - Startup.
  - Do not drain the boiler unless it will be exposed to freezing temperatures. If using freeze prevention fluid in system, do not drain.
2. Allow time for the boiler to cool to room temperature if it has been firing.
3. Remove the top access panel to remove the gas/air manifold assembly.
4. Remove the nuts securing the burner to the burner mounting plate. Remove the burner (FIG. 11-2).
5. Remove the nuts securing the burner mounting plate from the heat exchanger and set aside. Remove the entire burner mounting plate assembly.

#### ⚠ WARNING

The boiler contains ceramic fiber materials. Use care when handling these materials per instructions on this page. Failure to comply could result in severe personal injury.

6. Use a vacuum cleaner to remove any accumulation on the tube sheet surfaces. Do not use any solvent.
7. Brush the heat exchanger (tube sheet, combustion chamber walls, and tube entry) while dry using a nylon bristle brush. **Caution:** DO NOT use a metal brush. Re-vacuum the heat exchanger.
8. Finish cleaning using a clean cloth dampened with warm water.
9. Temporarily remove the condensate drain line from the condensate trap and route directly to a drain.
10. Rinse out debris with a low pressure water supply. The water will drain through the condensate connection.
11. Allow the heat exchanger to thoroughly dry.
12. Reconnect the condensate drain line to the condensate trap.
13. Close isolation valves on piping to isolate boiler from system. Attach a hose to the boiler drain and flush boiler thoroughly with clean water by using purging valves to allow water to flow through the water make-up line to the boiler.
14. When securing the burner, be sure to tighten the nuts, but DO NOT over-tighten. Tighten the nuts to a torque setting of no more than 6.2 ft.-lbs. When securing the burner mounting plate be sure to tighten the nuts, but DO NOT over-tighten. Tighten the nuts to a torque setting of no more than 15.5 ft.-lbs.

15. Replace the burner mounting plate assembly and gas/air manifold assembly. Ensure gaskets are in good condition and positioned properly. Restore boiler to operation.
16. Perform start-up and check-out procedures in the Check Flame and Combustion - Section 9 - Startup of the Crest Installation and Operation Manual.

### Handling ceramic fiber materials

#### REMOVAL OF COMBUSTION CHAMBER LINING

#### ⚠ WARNING

The combustion chamber insulation in this appliance contains ceramic fiber material. Ceramic fibers can be converted to cristobalite in very high temperature applications. The International Agency for Research on Cancer (IARC) has concluded, "Crystalline silica in the form of quartz or cristobalite from occupational sources is carcinogenic to humans (Group 1)." Normal operating temperatures in this appliance are below the level to convert ceramic fibers to cristobalite. Abnormal operating conditions would have to be created to convert the ceramic fibers in this appliance to cristobalite.

The ceramic fiber material used in this appliance is an irritant; when handling or replacing the ceramic materials it is advisable that the installer follow these safety guidelines.

- Avoid breathing dust and contact with skin and eyes.
  - Use NIOSH certified dust respirator (N95). This type of respirator is based on the OSHA requirements for cristobalite at the time this document was written. Other types of respirators may be needed depending on the job site conditions. Current NIOSH recommendations can be found on the NIOSH website at <http://www.cdc.gov/niosh/homepage.html>. NIOSH approved respirators, manufacturers, and phone numbers are also listed on this website.
  - Wear long-sleeved, loose fitting clothing, gloves, and eye protection.
- Apply enough water to the combustion chamber lining to prevent airborne dust.
- Remove the combustion chamber lining from the boiler and place it in a plastic bag for disposal.
- Wash potentially contaminated clothes separately from other clothing. Rinse clothes washer thoroughly.

#### NIOSH stated First Aid.

- Eye: Irrigate immediately.
- Breathing: Fresh air.

### 3 Troubleshooting

**⚠ WARNING**

Label all wires prior to disconnection when servicing controls. Wiring errors can cause improper and dangerous operation. Always disconnect power to the boiler before servicing. Failure to comply could result in severe personal injury, death, or substantial property damage.

**⚠ WARNING**

Never jumper (bypass) any device except for momentary testing as outlined in the Troubleshooting chart. Severe personal injury, death, or substantial property damage can result.

#### Before troubleshooting:

1. Have the following items:
  - a. Voltmeter that can check 120 vac, 24 vac, and 12 vdc.
  - b. Continuity checker.
  - c. Contact thermometer.
2. Check for 120 vac (minimum 102 vac to maximum 132 vac) to boiler.
3. Make sure thermostat is calling for heat and contacts are closed. Check for 24 vac between thermostat wire nuts and ground.
4. Make sure all external limit controls are installed and operating.

#### Check the following:

1. Wire connectors to control module are securely plugged in at the module and originating control.
2. Gas pressures:
  - Maximum: 14 inches w.c. (3.5 kPa) (natural and LP) with no flow (lockup) or with boiler on
  - Minimum: 4 inches w.c. (1.0 kPa) (natural and LP), with gas flowing (verify during boiler startup)

#### Check control module fuses

**NOTICE**

ALWAYS check control module fuses before replacing control module or any major components (blower, etc.). If one of these fuses is blown, it can prevent the control module or other components from operating.

1. Turn OFF the power to the boiler at the external line switch.
2. Remove the upper and lower doors.
3. Remove the four (4) screws securing the control panel cover to the unit to gain access to the control module.
4. Inspect fuses F2, F4, and F5, see FIG 3-1 below.

**Figure 3-1 Control Module Fuses**

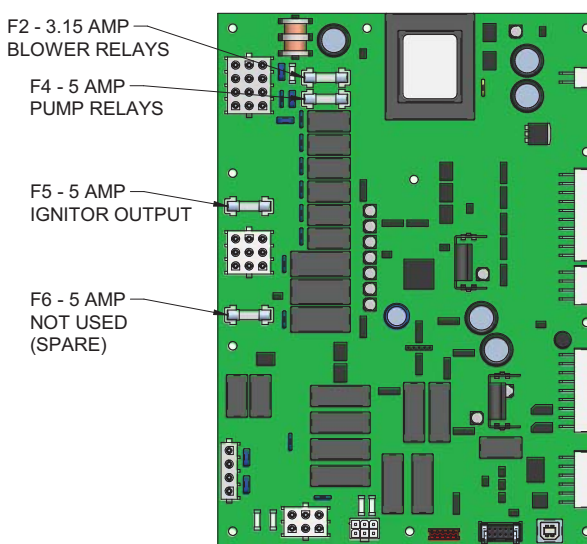

5. The boiler is shipped with four (4) spare fuses in a plastic bag located inside the control panel.
6. If necessary, replace open fuse (F2 is 3.15 amps, F4, F5 and F6 are 5 amps each).

**Note:** Fuses F2, F4, F5 and F6 are all slow blow fuses.

**⚠ WARNING**

Do not jumper fuse or replace with any fuse except as specified. Failure to comply could result in severe personal injury, death, or substantial property damage.

7. Re-install the control panel cover using the four (4) screws removed in Step 3. Re-install the upper and lower doors after fuse inspection.
8. Restore power to the boiler at the external line switch and verify boiler operation (Section 9 - Start-up in the Crest Installation and Operation Manual) after completing boiler service.



### 3 Troubleshooting *(continued)*

**Table 3A** Troubleshooting Chart - No Display

FAULT	CAUSE	CORRECTIVE ACTION
No Display	- No 120 vac supplied to unit.	<ul style="list-style-type: none"> <li>• Check external line switch, fuse, or breaker.</li> <li>• Check position of ON/OFF switch. Turn switch to the ON position.</li> <li>• Check 120 vac through the ON/OFF switch.</li> <li>• Check wiring harness connection between display board and main control board. Connect harness at both points.</li> </ul>
	- No voltage through the switch.	<ul style="list-style-type: none"> <li>• Replace switch.</li> </ul>
	- Bad display board.	<ul style="list-style-type: none"> <li>• Replace board.</li> </ul>
	- Bad main control board.	<ul style="list-style-type: none"> <li>• Replace the main control board.</li> </ul>
	- Blown fuse.	<ul style="list-style-type: none"> <li>• Replace fuse F2 on the main control board, see page 38 of this manual.</li> </ul>
No Burner Operation	- Main control board temperature set point satisfied.	<ul style="list-style-type: none"> <li>• Review temperature setting.</li> </ul>
	- Remote thermostat satisfied.	<ul style="list-style-type: none"> <li>• Review remote thermostat setting.</li> </ul>
	- Outside air temperature above Warm Weather Shutdown (WWSD) set point for main control board.	<ul style="list-style-type: none"> <li>• Check location of outside air sensor. Check resistance of outdoor air sensor and compare to Table 3C on page 38 of this manual.</li> </ul>
	- Unit locked out on fault.	<ul style="list-style-type: none"> <li>• Consult display for specific fault. Refer to fault descriptions on page 40 of this manual for corrective actions.</li> </ul>
Unit Does Not Modulate Up to 100%	- Ramp delay active.	<ul style="list-style-type: none"> <li>• Check ramp delay parameter settings. Optional PC software required.</li> </ul>
		<ul style="list-style-type: none"> <li>• Turn ramp delay feature off. See page 20 of this manual for instructions on how to turn this feature off.</li> </ul>
	- Boiler controlled by BMS.	<ul style="list-style-type: none"> <li>• Check BMS parameter settings.</li> </ul>

# 3 Troubleshooting

## Checking temperature sensors

The boiler temperature sensors (inlet water, outlet water, system water, flue, and outdoor air) are all resistance type devices. The following tables show the correct values for the sensors at various temperatures. Use an ohmmeter to read the resistance of the sensor at a known temperature. If the resistance of the sensor does not closely match its corresponding table, replace the sensor

It is important to note that the flue and outlet inlet air - S11/S13 #1 and S12/S14 #2 water sensors have two temperature sensing devices in one housing. These devices are designated as S1/S9, outlet sensor and S3/S10, flue sensor. Please reference the wiring diagram in the Crest Installation and Operation Manual for correct terminal location.

**Table 3B - Inlet Water/System Sensor Resistance vs. Temperature**

Temperature	Resistance	Temperature	Resistance
50	18,780	158	1,990
68	12,263	176	1,458
86	8,194	194	1,084
104	5,592	212	817
122	3,893		
140	2,760		

**Table 3C - Outdoor Air Sensor Resistance vs. Temperature**

Temperature	Resistance	Temperature	Resistance
-50	490,813	20	46,218
-40	336,606	30	34,558
-30	234,196	40	26,099
-20	165,180	50	19,900
10	118,018	60	15,311
0	85,362	70	11,883
10	62,465	80	9,299

**Table 3D - Outlet Water Sensor Resistance vs. Temperature**

Outlet	S1	R/Y	Outlet	S9	RW/Y
Pre-Mix Air 1	S11	GY/Y	Pre-Mix Air 1	S13	BR/Y
Pre-Mix Air 2	S12	BK/Y	Pre-Mix Air 2	S14	T/Y
Temperature	Resistance	Temperature	Resistance	Temperature	Resistance
50	19,553	158	2,004	50	40,030
68	12,690	176	1,464	68	25,030
86	8,406	194	1,084	86	16,090
104	5,715	212	816	104	10,610
122	3,958			122	7,166
140	2,786			140	4,943

**Table 3E - Flue Sensor Resistance vs. Temperature**

Flue	S3	GY/Y	Flue	S10	W/Y
Temperature	Resistance	Temperature	Resistance	Temperature	Resistance
50	40,030	158	3,478	50	258,500
68	25,030	176	2,492	68	125,500
86	16,090	194	1,816	86	80,220
104	10,610	212	1,344	104	52,590
122	7,166			122	35,270
140	4,943			140	24,160

### 3 Troubleshooting *(continued)*

**Table 3F** Troubleshooting Chart - Noisy System

FAULT	CAUSE	CORRECTIVE ACTION
Noisy Operation	<ul style="list-style-type: none"> <li>- Supply gas problem. Natural and LP gas pressures should be between 4 inches w.c. (1.0 kPa) and 14 inches w.c. (3.5 kPa).</li> </ul>	<ul style="list-style-type: none"> <li>• Refer to Section 6 - Gas Connections of the Crest Installation and Operation Manual for detailed information concerning the gas supply.</li> </ul>
	<ul style="list-style-type: none"> <li>- Gas/air mixture problem.</li> </ul>	<ul style="list-style-type: none"> <li>• Refer to the Gas Valve Adjustment Procedure on page 53 of this manual for the proper gas valve setting. Verify that the vent/air intake lengths do not exceed the maximum listed in the General Venting section of the Crest Installation and Operation Manual.</li> </ul>
	<ul style="list-style-type: none"> <li>- Dirty/damaged burner.</li> </ul>	<ul style="list-style-type: none"> <li>• Refer to page 34 in this manual for the burner removal and inspection procedure. Clean or replace the burner as necessary.</li> </ul>
	<ul style="list-style-type: none"> <li>- Air in the piping system.</li> </ul>	<ul style="list-style-type: none"> <li>• Properly purge all air from the piping system.</li> </ul>
No Pump Operation - Boiler Pump System Pump or HWG Pump	<ul style="list-style-type: none"> <li>- Blown fuse.</li> </ul>	<ul style="list-style-type: none"> <li>• Replace fuse F4 on the control board, see page 36 of this manual.</li> </ul>
	<ul style="list-style-type: none"> <li>- Faulty pump.</li> </ul>	<ul style="list-style-type: none"> <li>• Replace pump.</li> </ul>
	<ul style="list-style-type: none"> <li>- Internal fault on control board.</li> </ul>	<ul style="list-style-type: none"> <li>• Replace main control board.</li> </ul>
	<ul style="list-style-type: none"> <li>- Faulty pump relay.</li> </ul>	<ul style="list-style-type: none"> <li>• Replace relay.</li> </ul>
	<ul style="list-style-type: none"> <li>- Incorrect parameter setting.</li> </ul>	<ul style="list-style-type: none"> <li>• Reference the Boiler Pump Mode and System Pump Mode parameters in the Service section of this manual.</li> </ul>
Relief Valve Opening	<ul style="list-style-type: none"> <li>- System pressure exceeds relief valve setting.</li> </ul>	<ul style="list-style-type: none"> <li>• Lower the system pressure below the rating of the supplied relief valve or replace the standard relief valve with a higher rated valve up to the maximum pressure of the heat exchanger 160 psi (40 kPa).</li> <li>• Improperly sized expansion tank.</li> </ul>

# 3 Troubleshooting

**Table 3G** Troubleshooting Chart - Fault Messages Displayed on Boiler Interface

FAULT	DESCRIPTION	CORRECTIVE ACTION
<p>Gas Pressure SW Open (will require a manual reset once the condition has been corrected. Press the RESET button on the SMART TOUCH display to reset.)</p>	<p>Either the low gas pressure switch or one of the high gas pressure switches tripped.</p>	<ul style="list-style-type: none"> <li>• Measure the supply gas pressure to determine cause of failure. Natural and LP gas pressures should be between 4 - 14 inches w.c. (1.0 - 3.5 kPa).</li> <li>• Refer to Section 6 - Gas Connections of the Crest Installation and Operation Manual for detailed information concerning the gas supply.</li> <li>• Correct the supply gas pressure if necessary.</li> </ul>
<p>Low Water Cutoff Open (will require a manual reset once condition has been corrected. Press the RESET button on the SMART TOUCH display to reset.)</p>	<p>The low water cutoff is not making.</p>	<ul style="list-style-type: none"> <li>• Reset the LWCO from the RESET button on the front control panel.</li> <li>• Verify system is full of water and all air has been purged from the system.</li> <li>• Check for loose or misplaced jumpers if flow switch or LWCO is not installed.</li> </ul>
	<p>Blown fuse.</p>	<ul style="list-style-type: none"> <li>• Replace fuse F2 on the control board, see page 38 of this manual.</li> </ul>
<p>Blocked Drain SW Open (will require a manual reset once condition has been corrected. Press the RESET button on the SMART TOUCH display to reset.)</p>	<p>The blocked drain switch has detected excessive condensate build up inside the unit.</p>	<ul style="list-style-type: none"> <li>• Check condensate tube from unit to floor drain for proper installation and obstructions.</li> <li>• Inspect condensate trap for blockage. Clean if necessary.</li> <li>• Check for loose wiring connection at wire harness plug.</li> <li>• Bad blocked drain switch. Replace switch.</li> </ul>
<p>APS Open (will require a manual reset once the condition has been corrected. Press the RESET button on the SMART TOUCH display to reset.)</p>	<p>Blocked flue/inlet pressure switch contacts are open.</p>	<ul style="list-style-type: none"> <li>• Check the wiring connections to switch. Wires should be connected to the common and normally closed terminals.</li> <li>• Vent/air intake lengths exceed the maximum allowed lengths. Refer to Section 2 - General Venting of the Crest Installation and Operation Manual for proper lengths.</li> <li>• Check for obstruction or blockage in the vent/air intake pipes or at terminations.</li> <li>• Check reference hose and tubing connected to the pressure switch for blockage or obstruction.</li> <li>• Inspect the burner. Reference page 34 of this manual for removal and cleaning procedures. Replace if necessary.</li> <li>• Inspect the heat exchanger. Reference page 35 of this manual for removal and cleaning procedures. Replace if necessary.</li> <li>• Faulty air pressure switch. Replace switch.</li> <li>• Verify combustion air blower is operating. Replace if necessary.</li> </ul>

### 3 Troubleshooting *(continued)*

**Table 3G** *(continued from previous page) Troubleshooting Chart - Fault Messages Displayed on Boiler Interface*

FAULT	DESCRIPTION	CORRECTIVE ACTION
Anti-cycling	The main control board has received a call for heat too quickly after the previous call for heat has ended.	<ul style="list-style-type: none"> <li>• The control board will release the call for heat after a set time period.</li> <li>• The control board will release the call for heat if the outlet temperature drops too quickly.</li> </ul>
<p>Flame Failure Ignition (will require a manual reset once the condition has been corrected. Press the RESET button on the SMART TOUCH display to reset.)</p>	The unit has failed to prove main burner ignition. It will require a manual reset before attempting to fire again.	<ul style="list-style-type: none"> <li>• Inspect spark electrode and associated wiring for damage and connection. Reference page 34 of this manual for removal and cleaning procedures. Replace if necessary.</li> <li>• Visually check for presence of a spark from the view port.</li> <li>• Check for proper electrical grounding of the unit.</li> <li>• Check incoming supply gas pressure. Natural and LP gas pressures should be between 4 - 14 inches w.c. (1.0 - 3.5 kPa). Refer to Section 6 - Gas Connections of the Crest Installation and Operation Manual for detailed information concerning the gas supply.</li> <li>• Verify that the plastic hose from gas valve 1 to the air inlet is connected and is not damaged.</li> <li>• Verify that the vent/air intake pipes are correctly installed and that there are no obstructions.</li> <li>• If 120 vac is present at the main control board, check the wiring between the main control board and the gas valve. Replace the wiring if necessary. Do not disconnect the wiring from the gas valve and attempt to measure voltage at that point. The main control board can detect if the gas valve is not connected and will display the Gas Valve / Connection fault.</li> <li>• If 120 vac is present, check the outlet of the valve to ensure the valve is flowing gas. With a manometer connected to the outlet tap of the gas valve, when the unit is in the prepurge period, there should be a negative pressure present. When the valve is energized a change in pressure should occur. If the pressure change does not occur, the gas valve is not opening. Replace the gas valve.</li> <li>• Inspect flame sensor and associated wiring. Reference page 34 of this manual for removal and cleaning procedures. Replace if necessary.</li> <li>• Inspect the burner. Reference page 34 of this manual for removal and cleaning procedures. Replace if necessary.</li> </ul>

### 3 Troubleshooting

**Table 3G** (continued from previous page) Troubleshooting Chart - Fault Messages Displayed on Boiler Interface

FAULT	DESCRIPTION	CORRECTIVE ACTION
<p>Flame Out of Sequence 1 (will require a manual reset once the condition has been corrected. Press the RESET button on the SMART TOUCH display to reset.)</p>	<p>The flame detector 1 circuit is seeing a flame signal while no flame is present.</p>	<ul style="list-style-type: none"> <li>• Check supply voltage for proper polarity.</li> <li>• Check external wiring for voltage feedback.</li> <li>• Check the internal wiring for bad connections.</li> </ul>
<p>Flame Out of Sequence 2 (will require a manual reset once the condition has been corrected. Press the RESET button on the SMART TOUCH display to reset.)</p>	<p>The flame detector 2 circuit is seeing a flame signal from burner 1.</p>	<ul style="list-style-type: none"> <li>• Check combustion of burner 1 and adjust valve 1 if necessary.</li> <li>• Check supply voltage for proper polarity.</li> <li>• Check external wiring for voltage feedback.</li> <li>• Check the flame rod and make sure it is clean.</li> <li>• Check internal wiring for bad connections.</li> <li>• Remove and inspect the burner.</li> </ul>
<p>Flame Failure Running 1 (will require a manual reset once the condition has been corrected. Press the RESET button on the SMART TOUCH display to reset.)</p>	<p>The unit was running and lost the flame signal.</p>	<ul style="list-style-type: none"> <li>• Inspect flame rod 1 and associated wiring for damage and connection. Reference page 34 of this manual for removal and cleaning procedures. Replace if necessary.</li> <li>• Check for proper electrical grounding of unit.</li> <li>• Check incoming supply gas pressure. Natural and L.P. gas pressures should be between 4 - 14 inches w.c. (1.0 - 3.5 kPa). Refer to Section 6 - Gas Connections of the Crest Installation and Operation Manual for detailed information concerning the gas supply.</li> <li>• Verify that the plastic hose from the gas valve to the air inlet is connected and is not damaged.</li> <li>• Verify that the vent/air intake pipes are installed correctly and there are no obstructions.</li> <li>• Inspect flame sensor and associated wiring. Reference page 34 of this manual for removal and cleaning procedures. Replace if necessary.</li> <li>• Check combustion.</li> <li>• Inspect the burner. Reference page 34 of this manual for removal and cleaning procedures. Replace if necessary.</li> </ul>



### 3 Troubleshooting *(continued)*

**Table 3G** *(continued from previous page) Troubleshooting Chart - Fault Messages Displayed on Boiler Interface*

FAULT	DESCRIPTION	CORRECTIVE ACTION
<p>Flame Failure Running 2 (will require a manual reset once the condition has been corrected. Press the RESET button on the SMART TOUCH display to reset.)</p>	<p>The unit was running and lost the flame signal.</p>	<ul style="list-style-type: none"> <li>• Inspect flame rod 2 and associated wiring for damage and connection. Reference page 34 of this manual for removal and cleaning procedures. Replace if necessary.</li> <li>• Check for proper electrical grounding of unit.</li> <li>• Check incoming supply gas pressure. Natural and L.P. gas pressures should be between 4 - 14 inches w.c. (1.0 - 3.5 kPa). Refer to Section 6 - Gas Connections of the Crest Installation and Operation Manual for detailed information concerning the gas supply.</li> <li>• Verify that the plastic hose from the gas valve to the air inlet is connected and is not damaged.</li> <li>• Verify that the vent/air intake pipes are installed correctly and there are no obstructions.</li> <li>• Inspect flame sensor and associated wiring. Reference page 34 of this manual for removal and cleaning procedures. Replace if necessary.</li> <li>• Check combustion.</li> <li>• Inspect the burner. Reference page 34 of this manual for removal and cleaning procedures. Replace if necessary.</li> </ul>
<p>Gas Valve / Relay Failure 1 (will require a manual reset once the condition has been corrected. Press the RESET button on the SMART TOUCH display to reset.)</p>	<p>The main control board did not detect gas valve 1.</p>	<ul style="list-style-type: none"> <li>• Check wiring harness connection at the gas valve and at the main control board.</li> <li>• Replace the gas valve wire harness.</li> <li>• Replace the gas valve.</li> </ul>
<p>Gas Valve / Relay Failure 2 (will require a manual reset once the condition has been corrected. Press the RESET button on the SMART TOUCH display to reset.)</p>	<p>The main control board did not detect gas valve 2.</p>	<ul style="list-style-type: none"> <li>• Check wiring harness connection at the gas valve and at the main control board.</li> <li>• Replace the gas valve wire harness.</li> <li>• Replace the gas valve.</li> </ul>

### 3 Troubleshooting

**Table 3G** (continued from previous page) Troubleshooting Chart - Fault Messages Displayed on Boiler Interface

FAULT	DESCRIPTION	CORRECTIVE ACTION
<p>Auto Reset High Limit</p>	<p>The outlet water temperature has exceeded the setting of the automatic reset high limit.</p>	<ul style="list-style-type: none"> <li>• Verify that the system is full of water and that all air has been properly purged from the system.</li> <li>• Verify that the boiler is piped properly into the heating system. Refer to Section 5 - Hydronic Piping of the Crest Installation and Operation Manual for the proper piping methods for the Crest boiler.</li> <li>• Check 120 vac to boiler pump motor on a call for heat. If voltage is not present, check wiring back to the main control board.</li> <li>• Check the ARHL set point.</li> <li>• If 120 vac is present on a call for heat and the boiler pump is not operating, replace the pump.</li> <li>• If the system pump is a variable speed pump, ensure that the system flow is not less than the boiler flow.</li> <li>• If operating on something other than an outlet sensor, check temperature setting of the main control board.</li> <li>• If the optional manual reset high limit has tripped, check setting of the device.</li> <li>• Check resistance of water sensors and compare to Table 3B on page 38 of this manual. Replace sensor if necessary.</li> <li>• Replace the main control board.</li> </ul>
<p>Manual Reset High Limit Open (will require a manual reset once the condition has been corrected. Press the RESET button on the SMART TOUCH display to reset.)</p>	<p>The outlet water temperature has exceeded the setting of the high limit.</p>	<ul style="list-style-type: none"> <li>• Verify that the system is full of water and that all air has been properly purged from the system.</li> <li>• Verify that the boiler is piped properly into the heating system. Refer to Section 5 - Hydronic Piping of the Crest Installation and Operation Manual for the proper piping methods for the Crest boiler.</li> <li>• Check voltage to boiler pump motor on a call for heat. If voltage is not present, check wiring back to the main control board.</li> <li>• Replace the pump relay if necessary.</li> <li>• If 120 vac is present on a call for heat and the boiler pump is not operating, replace the pump.</li> <li>• If the system pump is a variable speed pump, ensure that the system flow is not less than the boiler flow.</li> <li>• If operating on either an inlet or system supply sensor, check temperature setting of the main control board.</li> <li>• If the high limit has tripped, check setting of the device and the MRHL set point.</li> <li>• Check resistance of water sensors and compare to Table 3B on page 38 of this manual. Replace sensor if necessary.</li> <li>• Replace high limit (if equipped).</li> <li>• Replace main control board.</li> </ul>

### 3 Troubleshooting *(continued)*

**Table 3G** (continued from previous page) *Troubleshooting Chart - Fault Messages Displayed on Boiler Interface*

FAULT	DESCRIPTION	CORRECTIVE ACTION
<p>Fan Speed Low 1 (will require a manual reset once the condition has been corrected. Press the RESET button on the SMART TOUCH display to reset.)</p>	<p>The actual fan 1 RPM is 30% lower than what is being called for.</p>	<ul style="list-style-type: none"> <li>• Vent/air intake lengths exceed the maximum allowed lengths. Refer to Section 2 - General Venting of the Crest Installation and Operation Manual for proper lengths.</li> <li>• Check for obstruction or blockage in the vent/air intake pipes or at terminations.</li> <li>• Check the wiring connections at fan 1 and at the main control board.</li> <li>• Replace the fan.</li> </ul>
	<p>Blown fuse.</p>	<ul style="list-style-type: none"> <li>• Replace fuse F2 on the control board, see page 36 of this manual.</li> </ul>
<p>Fan Speed Low 2 (will require a manual reset once the condition has been corrected. Press the RESET button on the SMART TOUCH display to reset.)</p>	<p>The actual fan 2 RPM is 30% lower than what is being called for.</p>	<ul style="list-style-type: none"> <li>• Vent/air intake lengths exceed the maximum allowed lengths. Refer to Section 2 - General Venting of the Crest Installation and Operation Manual for proper lengths.</li> <li>• Check for obstruction or blockage in the vent/air intake pipes or at terminations.</li> <li>• Check the wiring connections at fan 2 and at the main control board.</li> <li>• Replace the fan.</li> </ul>
	<p>Blown fuse.</p>	<ul style="list-style-type: none"> <li>• Replace fuse F2 on the control board, see page 36 of this manual.</li> </ul>
<p>Fan Speed High 1 (will require a manual reset once the condition has been corrected. Press the RESET button on the SMART TOUCH display to reset.)</p>	<p>The actual fan 1 RPM is 30% higher than what is being called for.</p>	<ul style="list-style-type: none"> <li>• Vent/air intake lengths exceed the maximum allowed lengths. Refer to Section 2 - General Venting of the Crest Installation and Operation Manual for proper lengths.</li> <li>• Check for obstruction or blockage in the vent/air intake pipes or at terminations.</li> <li>• Check the wiring connections at the fan and at the main control board.</li> <li>• Replace the fan.</li> </ul>
<p>Fan Speed High 2 (will require a manual reset once the condition has been corrected. Press the RESET button on the SMART TOUCH display to reset.)</p>	<p>The actual fan 2 RPM is 30% higher than what is being called for.</p>	<ul style="list-style-type: none"> <li>• Vent/air intake lengths exceed the maximum allowed lengths. Refer to Section 2 - General Venting of the Crest Installation and Operation Manual for proper lengths.</li> <li>• Check for obstruction or blockage in the vent/air intake pipes or at terminations.</li> <li>• Check the wiring connections at the fan and at the main control board.</li> <li>• Replace the fan.</li> </ul>

# 3 Troubleshooting

**Table 3G** (continued from previous page) Troubleshooting Chart - Fault Messages Displayed on Boiler Interface

FAULT	DESCRIPTION	CORRECTIVE ACTION
<p>Louver Proving Sw Open (will require a manual reset once the condition has been corrected. Press the RESET button on the SMART TOUCH display to reset.)</p>	<p>An optional remote proving switch is not making.</p>	<ul style="list-style-type: none"> <li>• Check function of remote devices.</li> <li>• Check for loose or misplaced jumper if proving switch is not installed.</li> </ul>
<p>Flue Temp High</p>	<p>The stack temperature has exceeded the set parameters for the boiler.</p>	<ul style="list-style-type: none"> <li>• Inspect the heat exchanger. Reference page 35 of this manual for the procedure on how to clean the flue side of the heat exchanger.</li> <li>• Inspect the flue sensor and associated wiring. Measure the resistance of the flue sensor and compare to Table 3E on page 38 of this manual. Replace the sensor if necessary.</li> <li>• Verify that the vent/air intake pipes are properly installed and that there are no obstructions.</li> </ul>
<p>Delta T High</p>	<p>The temperature rise across the heat exchanger has exceeded the set parameters for the boiler.</p>	<ul style="list-style-type: none"> <li>• Verify that the system is full of water and that all air has been properly purged from the system.</li> <li>• Verify that the boiler is piped properly into the heating system. Refer to Section 5 - Hydronic Piping of the Crest Installation and Operation Manual for the proper piping methods for the Crest boiler.</li> <li>• Check for 120 vac to the boiler pump motor on a call for heat. If voltage is not present, check the wiring back to the main control board. Replace the main control board if necessary.</li> <li>• If 120 vac is present on a call for heat and the boiler pump is not operating, replace the pump.</li> <li>• Verify that the boiler pump is set to the proper speed or that the pump is the proper size. Reference Section 5 - Hydronic Piping of the Crest Installation and Operation Manual for boiler pump specifications.</li> <li>• Inspect the inlet and outlet sensors and associated wiring. Measure the resistance of the sensors and compare to the tables on page 38 of this manual.</li> </ul>
<p>Outlet Temp High</p>	<p>Outlet water temperature has exceeded the maximum outlet water temperature.</p>	<ul style="list-style-type: none"> <li>• Verify that the system is full of water and that all air has been properly purged from the system.</li> <li>• Verify that the boiler is piped properly into the heating system. Refer to Section 5 - Hydronic Piping of the Crest Installation and Operation Manual for the proper piping methods for the Crest boiler.</li> <li>• Check for 120 vac to the boiler pump motor on a call for heat. If voltage is not present, check wiring back to the main control board. Replace the main control board if necessary.</li> <li>• If 120 vac is present on a call for heat and the boiler pump is not operating, replace the pump.</li> </ul>

### 3 Troubleshooting *(continued)*

**Table 3G** *(continued from previous page) Troubleshooting Chart - Fault Messages Displayed on Boiler Interface*

FAULT	DESCRIPTION	CORRECTIVE ACTION
<p>Outlet Temp High (continued)</p>	<p>Outlet water temperature has exceeded the maximum outlet water temperature.</p>	<ul style="list-style-type: none"> <li>• Verify that the boiler pump is set to the proper speed or that the boiler pump is the proper size. Reference Section 5 - Hydronic Piping of the Knight Boiler Installation and Operation Manual for boiler pump specifications.</li> <li>• Inspect the outlet sensors and associated wiring. Measure the resistance of the sensors and compare to the tables on page 38 of this manual.</li> </ul>
<p>Rem Ctrl Flt</p>	<p>External control is cycling too often.</p>	<ul style="list-style-type: none"> <li>• Check set point of the external control.</li> <li>• Check the wiring between the external control and the unit.</li> <li>• Replace the control.</li> </ul>
<p>Parameters Saved (will require a manual reset once the condition has been corrected. Press the RESET button on the SMART TOUCH display to reset.)</p>	<p>After downloading parameters from a laptop, the main control board must be reset.</p>	<ul style="list-style-type: none"> <li>• Press the RESET button on the SMART TOUCH display panel.</li> </ul>
<p>Service Blk</p>	<p>While the unit is in Service Mode, the outlet temperature has exceeded 185°F.</p>	<ul style="list-style-type: none"> <li>• Establish a heating load to remove the heat from the boiler loop.</li> <li>• Verify that the system is full of water and that all air has been properly purged from the system.</li> <li>• Verify that the boiler is piped properly into the heating system. Refer to Section 5 - Hydronic Piping of the Crest Installation and Operation Manual for the proper piping methods for the Crest boiler.</li> <li>• Check 120 vac to the boiler pump motor on a call for heat. If voltage is not present, check the wiring back to the main control board. Replace the main control board if necessary.</li> <li>• If 120 vac is present on a call for heat and the boiler pump is not operating, replace the pump.</li> <li>• Verify that the boiler pump is set to the proper speed or that the boiler pump is the proper size. Reference Section 5 - Hydronic Piping of the Crest Installation and Operation Manual for boiler pump specifications.</li> </ul>



### 3 Troubleshooting

**Table 3G** (continued from previous page) *Troubleshooting Chart - Fault Messages Displayed on Boiler Interface*

FAULT	DESCRIPTION	CORRECTIVE ACTION
<p>Sensor Open (will require a manual reset once the condition has been corrected. Press the RESET button on the display to reset.)</p>	<p>Either the inlet water or outlet water temperature sensor has been disconnected.</p>	<ul style="list-style-type: none"> <li>• Check the sensors and their associated wiring. Repair or replace the sensor or wiring if damaged.</li> <li>• Measure the resistance of the sensors and compare the resistance to the tables on page 38 of this manual.</li> <li>• Replace the sensor if necessary.</li> </ul>
<p>Sensor Shorted (will require a manual reset once the condition has been corrected. Press the RESET button on the display to reset.)</p>	<p>Either the inlet water or outlet water temperature sensor has been shorted.</p>	<ul style="list-style-type: none"> <li>• Check the sensors and their associated wiring. Repair or replace the sensor or wiring if damaged.</li> <li>• Measure the resistance of the sensors and compare the resistance to the tables on page 38 of this manual.</li> <li>• Replace the sensor if necessary.</li> </ul>
<p>Flue Sensor Open (will require a manual reset once the condition has been corrected. Press the RESET button on the display to reset.)</p>	<p>The flue sensor has been disconnected or removed from the flue.</p>	<ul style="list-style-type: none"> <li>• Check the sensor and its associated wiring. Repair or replace the sensor or wiring if damaged.</li> <li>• Measure the resistance of the sensors and compare the resistance to the tables on page 38 of this manual.</li> <li>• Replace the sensor in flue.</li> <li>• Replace the sensor if necessary.</li> </ul>
<p>Flue Sensor Shorted (will require a manual reset once the condition has been corrected. Press the RESET button on the display to reset.)</p>	<p>The flue sensor has been shorted.</p>	<ul style="list-style-type: none"> <li>• Check the sensor and its associated wiring. Repair or replace the sensor or wiring if damaged.</li> <li>• Measure the resistance of the sensors and compare the resistance to the tables on page 38 of this manual.</li> <li>• Replace the sensor if necessary.</li> </ul>
<p>Tank Open</p>	<p>Sensors equipped with an internal limit (such as the Lochinvar Squire® Indirect Tank), the limit has opened due to temperature (195°F) or the sensor has become disconnected.</p>	<ul style="list-style-type: none"> <li>• Check the tank temperature.</li> <li>• Repair or replace the sensor wiring if damaged.</li> <li>• Replace the sensor if necessary.</li> </ul>
<p>Blower Proving Switch Open 1 (will require a manual reset once the condition has been corrected. Press the RESET button on the display to reset.)</p>	<p>Blower proving pressure switch 1 contacts are open.</p>	<ul style="list-style-type: none"> <li>• Check the wiring connections to switch. Wires should be connected to the common and normally open terminals.</li> <li>• Remove switch and check for blockage in the orifice.</li> <li>• Vent/air intake lengths exceed the maximum allowed lengths. Refer to Section 2 - General Venting of the Crest Installation and Operation Manual for proper lengths.</li> <li>• Check for obstruction or blockage in the vent/air intake pipes or at terminations.</li> <li>• Inspect the burner. Reference page 34 of this manual for removal and cleaning procedures. Replace if necessary.</li> <li>• Verify combustion air blower 1 is operating. Replace if necessary.</li> <li>• Inspect the heat exchanger. Reference page 35 of this manual for removal and cleaning procedures.</li> <li>• Faulty pressure switch. Replace switch.</li> </ul>

### 3 Troubleshooting *(continued)*

**Table 3G** *(continued from previous page) Troubleshooting Chart - Fault Messages Displayed on Boiler Interface*

FAULT	DESCRIPTION	CORRECTIVE ACTION
<p>Blower Proving Switch Open 2 (will require a manual reset once the condition has been corrected. Press the RESET button on the display to reset.)</p>	<p>Pressure switch contacts are open.</p>	<ul style="list-style-type: none"> <li>• Check the wiring connections to switch. Wires should be connected to the common and normally open terminals.</li> <li>• Remove switch and check for blockage in the orifice.</li> <li>• Vent/air intake lengths exceed the maximum allowed lengths. Refer to Section 2 - General Venting of the Crest Installation and Operation Manual for proper lengths.</li> <li>• Check for obstruction or blockage in the vent/air intake pipes or at terminations.</li> <li>• Inspect the burner. Reference page 34 of this manual for removal and cleaning procedures. Replace if necessary.</li> <li>• Verify combustion air blower 2 is operating. Replace if necessary.</li> <li>• Inspect the heat exchanger. Reference page 35 of this manual for removal and cleaning procedures.</li> <li>• Faulty pressure switch. Replace switch.</li> </ul>
<p>Burner Supply Temperature Differential (will require a manual reset once the condition has been corrected. Press the RESET button on the display to reset.)</p>	<p>Combustion air to burner 1 temperature is higher than combustion air to burner 2 temperature or vice versa.</p>	<ul style="list-style-type: none"> <li>• Inspect the combustion air temperature sensor and associated wiring.</li> <li>• Measure the resistance of the combustion air temperature sensor and compare to Table 3E on page 38 of this manual</li> <li>• Replace the sensor if necessary.</li> <li>• Verify that the vent / air intake pipes are properly installed and that there are no obstructions.</li> </ul>
<p>Burner Supply Temperature High 1 (will require a manual reset once the condition has been corrected. Press the RESET button on the display to reset.)</p>	<p>Combustion air temperature is very high.</p>	<ul style="list-style-type: none"> <li>• Check if the vent backflow preventer is installed for boilers commonly vented.</li> <li>• Check if the vent backflow preventer is stuck open while the unit is off.</li> <li>• Inspect the combustion air temperature sensor and associated wiring.</li> <li>• Measure the resistance of the combustion air temperature sensor and compare to Table 3E on page 38 of this manual.</li> <li>• Replace the sensor if necessary.</li> </ul>
<p>Burner Supply Temperature High 2 (will require a manual reset once the condition has been corrected. Press the RESET button on the display to reset.)</p>	<p>Combustion air temperature is very high.</p>	<ul style="list-style-type: none"> <li>• Check if the vent backflow preventer is installed for boilers commonly vented.</li> <li>• Check if the vent backflow preventer is stuck open while the unit is off.</li> <li>• Inspect the combustion air temperature sensor and associated wiring.</li> <li>• Measure the resistance of the combustion air temperature sensor and compare to Table 3E on page 38 of this manual.</li> <li>• Replace the sensor if necessary.</li> </ul>

### 3 Troubleshooting

**Table 3G** (continued from previous page) *Troubleshooting Chart - Fault Messages Displayed on Boiler Interface*

FAULT	DESCRIPTION	CORRECTIVE ACTION
Too Many Resets - Try Later	Too many manual resets have occurred during a 15 minute period.	<ul style="list-style-type: none"> <li>• Wait 15 minutes and try again.</li> <li>• Turn power off to unit, wait 30 seconds and then turn power back on.</li> </ul>
Internal Fault	The main control board has detected an internal fault.	<ul style="list-style-type: none"> <li>• Replace the main control board.</li> </ul>
Writing to Memos	The main control board has detected an internal fault.	<ul style="list-style-type: none"> <li>• Replace the main control board.</li> </ul>
Flue Temp Shutdown	The stack temperature has exceeded the set parameters for the boiler.	<ul style="list-style-type: none"> <li>• Inspect the heat exchanger. Reference page 35 of this manual for the procedure on how to clean the flue side of the heat exchanger.</li> <li>• Inspect the flue sensor and associated wiring. Measure the resistance of the flue sensor and compare to Table 3E on page 38 of this manual. Replace the sensor if necessary.</li> <li>• Verify that the vent/air intake pipes are properly installed and that there are no obstructions.</li> <li>• Replace the main control board.</li> </ul>
Delta T Shutdown	The temperature rise across the heat exchanger has exceeded the set parameters for the boiler.	<ul style="list-style-type: none"> <li>• Verify that the system is full of water and that all air has been properly purged from the system.</li> <li>• Verify that the boiler is piped properly into the heating system. Refer to Section 5 - Hydronic Piping of the Crest Installation and Operation Manual for the proper piping methods for the Crest boiler.</li> <li>• Check for voltage to the boiler pump motor on a call for heat. If voltage is not present, check the wiring back to the pump relay. Replace the pump relay if necessary.</li> <li>• If 120 VAC is present on a call for heat and the boiler pump is not operating, replace the pump.</li> <li>• Verify that the boiler pump is set to the proper speed or that the pump is the proper size. Reference Section 5 - Hydronic Piping of the Crest Installation and Operation Manual for boiler pump specifications.</li> </ul>

### 3 Troubleshooting *(continued)*

**Table 3G** *(continued from previous page) Troubleshooting Chart - Fault Messages Displayed on Boiler Interface*

FAULT	DESCRIPTION	CORRECTIVE ACTION
Outlet Temp Shutdown	Outlet water temperature has exceeded the maximum outlet water temperature.	<ul style="list-style-type: none"> <li>• Verify that the system is full of water and that all air has been properly purged from the system.</li> <li>• Verify that the boiler is piped properly into the heating system. Refer to Section 5 - Hydronic Piping of the Crest Installation and Operation Manual for the proper piping methods for the Crest boiler.</li> <li>• Check for voltage to the boiler pump motor on a call for heat. If voltage is not present, check wiring back to the pump relay. Replace the pump relay if necessary.</li> <li>• If 120 VAC is present on a call for heat and the boiler pump is not operating, replace the pump.</li> </ul>
Watch Dog Error	The main control board has detected an internal fault.	<ul style="list-style-type: none"> <li>• Replace the main control board.</li> </ul>
Write EEPROM	The main control board has detected an internal fault.	<ul style="list-style-type: none"> <li>• Replace the main control board.</li> </ul>
CRC Parameters	The main control board has detected an internal fault.	<ul style="list-style-type: none"> <li>• Replace the main control board.</li> </ul>
No Error Stored	The main control board has detected an internal fault.	<ul style="list-style-type: none"> <li>• Press the RESET button on the SMART TOUCH display panel.</li> </ul>

# 3 Troubleshooting

## Combustion Analysis Procedure

1. Turn the main power off to the boiler by placing the "On/Off" switch in the OFF position.
2. Remove the flue temperature sensor from the flue collector. **Note:** Combustion measurements will be made at this point.
3. Turn the main power on to the boiler by placing the "On/Off" switch in the ON position.
4. Navigate to the Service Screen from the Home Screen by pressing the MAIN MENU button and then the SERVICE button.
5. On the Service Screen place heater into Service Mode by selecting the START button, then selecting **Set Gas Valve 1 - High**.
6. Insert the probe from a combustion analyzer into the hole left by the removal of the flue temperature sensor.
7. Once the heat exchanger has modulated up to rate, measure the combustion. The values should be in the range listed in Table 3I. CO levels should be less than 200 ppm for a properly installed unit. If the combustion is not within range reference the Troubleshooting Chart below for possible causes and corrective actions.

**Table 3I** Flue Products

Gas Valve	Natural Gas		Propane	
	CO <sub>2</sub>	O <sub>2</sub>	CO <sub>2</sub>	O <sub>2</sub>
1 - High	3.5% - 5.5%	11.2% - 14.8%	5.1% - 6.8%	10.5% - 13.2%
2 - High	7.8% - 8.6%	5.6% - 7.1%	9.4% - 11.0%	4.1% - 6.6%

8. After **Gas Valve 1** is set, repeat the same procedure for the second gas train by selecting **Set Gas Valve 2 - High** on the Service Screen.
9. Once the heater analysis is complete, test the safety shutoff device by turning the manual shutoff valve to the OFF position and ensuring that the heater shuts down and registers an alarm. Open the manual shutoff valve and reset the control.
10. Turn the main power off to the boiler and replace the flue temperature sensor into the flue pipe connection.
11. Place the boiler back into normal operation.

**⚠ WARNING**

You must replace the flue gas temperature sensor to prevent flue gas spillage into the room. Failure to comply could result in severe personal injury, death, or substantial property damage.

**Table 3H** Troubleshooting Chart - Combustion Levels

POSSIBLE CAUSE	CORRECTIVE ACTION
Vent/Air Intake Length or Obstruction	<ul style="list-style-type: none"> <li>• Refer to Section 2 - General Venting of the Crest Installation and Operation Manual for the proper venting and air intake methods for the Crest boiler.</li> <li>• Check for obstructions at the vent/air intake terminals.</li> </ul>
Gas Supply Pressure	<ul style="list-style-type: none"> <li>• Refer to Section 6 - Gas Connections of the Crest Installation and Operation Manual for the proper gas supply for the Crest boiler.</li> </ul>
Dirty/Damaged Burner	<ul style="list-style-type: none"> <li>• Refer to page 34 of this manual for burner removal and cleaning procedures.</li> <li>• Replace burner if necessary.</li> </ul>
Gas Valve Adjustment	<ul style="list-style-type: none"> <li>• Refer to page 53 of this manual for the gas valve adjustment procedure.</li> </ul>



### 3 Troubleshooting *(continued)*

#### Gas valve adjustment procedure

**CAUTION**

Under normal operating conditions this valve should not need adjusting.

Locate the throttle adjustment screw on the gas valve. For Models 1.5 and 2.0 see FIG. 3-2, for Model 2.5 see FIG. 3-3 and for Models 3.0 and 3.5 see FIG. 3-4. Using a screwdriver, turn the screw a 1/4 turn **counterclockwise** to increase CO<sub>2</sub> levels or a 1/4 turn **clockwise** to decrease CO<sub>2</sub> levels. After one adjustment on the valve, follow the Combustion Analysis Procedure on page 52 of this manual to measure the combustion.

If combustion is still not within the specified range, repeat the procedure. This procedure **SHOULD NOT** be performed more than four (4) times. If after four (4) adjustments and the combustion is still not within the specified range, revisit the possible causes in Table 3H on page 52 or replace the gas valve.

**Figure 3-3** Gas Valve Adjustment: Model 2.5

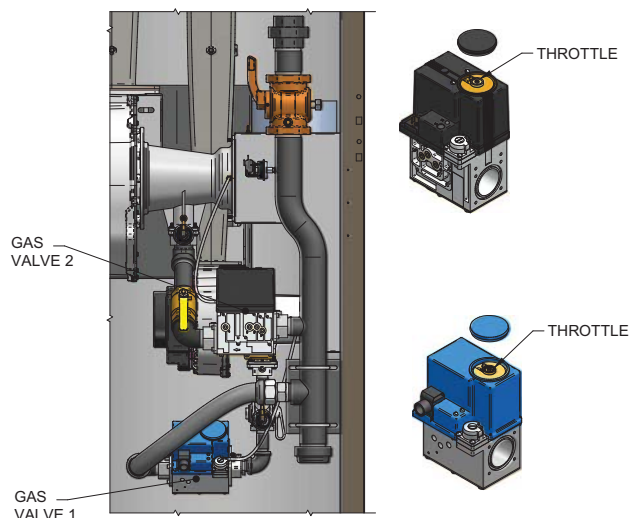

**Figure 3-4** Gas Valve Adjustment: Models 3.0 and 3.5

**Figure 3-2** Gas Valve Adjustment: Models 1.5 and 2.0

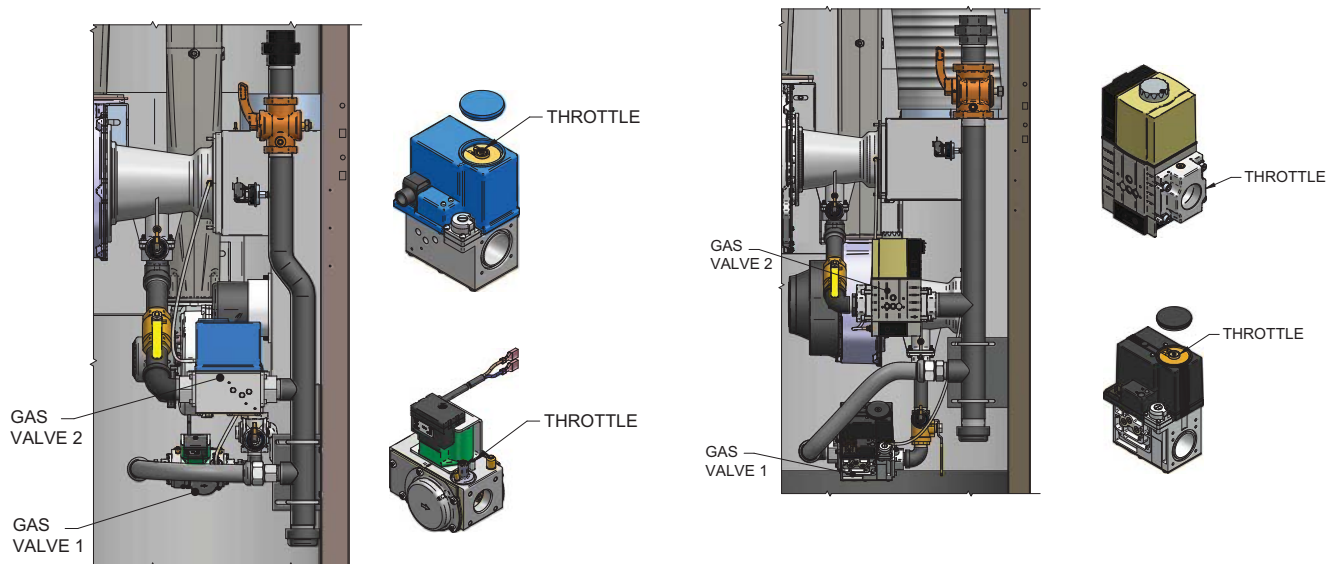



# NOTES

**Revision Notes:** Revision A (ECO #C08179) initial release.

Revision B (ECO C08436) reflects changes made to the parameter table, notice added to the parameter descriptions, changed out the screens on FIG.'s 1-8 and 1-14.