



M2400S™

2.4 GHz Wireless Broadband System

USER MANUAL

October 18, 2004
Revision A
for Firmware Version 1.0

Table of Contents

Preface	iv
FCC Information	iv
Warranty Information	iv
Firmware Notifications	iv
Section 1 Introduction	1
Overview	1
SmartPolling™ & Bandwidth Throttling	2
Auto-retransmit Feature (ARQ)	2
Section 2 Hardware Overview	3
M2400S AP and SU Hardware Components	3
Section 3 Getting Started	4
Connections and Power	4
Radio Management Concepts	5
Browser Interface	6
Command Line Interface	9
Telnet	9
Troubleshooting	10
Section 4 Basic Configuration via Browser Interface	11
Configuring the AP Subscriber Unit Database	11
Creating an SU in the SU Database	12
Configure Other Basic AP Parameters	13
Configure Basic SU Parameters	15
Link Control Page	16
RF Link Loopback Test	17
SU Ranging Test	18
Advanced Setup Page	18
Other Key Parameters	19
Site Survey Page	20
Basic Configuration via CLI	21
Access Point Basic Settings	21
Subscriber Unit Database Settings	24
Subscriber Unit Basic Settings	25
Section 5 Mounting Hardware	28
Cabling and Grounding Considerations	29
Section 6 Deployment	30
Site Selection	30
Site Survey	30
AP Search and SU Antenna Alignment	31
Link Management Commands	33
ARQ with Selected Repeat and Multirate Feature	36
Section 7 Management	36
Radio Management Access Via TCP/IP	36
SU Management from AP	36
Loading Multiple SU's into SUDB using DLOAD Command	37
SNMP	38
Objects for Monitoring and Control	38
SNMP Setup	38
Appendix A Command Set Reference	40
Appendix B Specifications	44

Table of Figures

Figure 1: Typical Deployment	1
Figure 2: Basic Components of an M2400S Radio	3
Figure 3: Bottom of Radio	3
Figure 4: Back of Radio	4
Figure 5: Side of Radio & Location of Reverse Polarity SMA Connector	4
Figure 6: Wiring Diagram	5
Figure 7: LED Summary	16
Figure 8: M2400S Mounting Hardware Assembly	28
Figure 9: Articulation for M2400S with Mono Pod Mount (not supplied)	28
Figure 10: Grounding of Radio	29

Preface

This manual covers basic configuration and installation of the M2400S Wireless Broadband System and applies to the following radio part numbers:

M2400S-AP	2.4 GHz Access Point
M2400S-SU	2.4 GHz Subscriber Unit

FCC Information

This device complies with Part 15 of FCC Rules and Regulations. Operation is subject to the following two conditions: (1) This device may not cause harmful interference, and (2) this device must accept any interference received, including interference that may cause undesired operation.

This equipment has been tested and found to comply with the limits for a Class B digital device, pursuant to Part 15 of the FCC Rules. These limits are designed to provide reasonable protection against harmful interference in a residential installation. This equipment generates, uses, and radiates radio-frequency energy; if not installed and used in accordance with these instructions, the unit may cause harmful interference to radio communications. However, there is no guarantee that interference will not occur in any particular installation. If this equipment does cause harmful interference to radio or television reception, which can be determined by turning the equipment off and on, the user is encouraged to correct the interference by one or more of the following measures:

- 1) Reorient the antenna.
- 2) Increase the separation between the affected equipment and the unit.
- 3) Connect the affected equipment to a power outlet on a different circuit from the one the receiver is connected to.
- 4) Consult the dealer and/or experienced radio/TV technician for help.

FCC ID: NCYM2400S

Canada:

IMPORTANT NOTE: Intentional or unintentional changes or modifications must not be made unless under the express consent of the party responsible for compliance. Any such modifications could void the user's authority to operate the equipment and will void the manufacturer's warranty. To comply with FCC RF exposure requirements, the following antenna installation and device operating configurations must be satisfied. The antenna for this unit must be fixed and mounted on an outdoor permanent structure with a minimum separation distance of two meters from any persons. Furthermore, it must not be co-located or operated in conjunction with any other antenna or transmitter.

Warranty Information

Radios from Trango Broadband Wireless are warranted for one year from date of purchase. Please see www.trangobroadband.com for a complete description of warranty coverage and limitations.

Firmware Notifications

To receive email notifications regarding firmware upgrades and product announcements, register at <http://www.trangobroadband.com/maillinglist/maillingListAdd.aspx>

Section 1 Introduction

Your Trango Broadband M2400S radio system provides a reliable and robust means to deliver broadband access to a wide geographic region through wireless Ethernet connectivity. This section will familiarize you with basic operational concepts, as well as an overview of the various components and hardware of the M2400S system.

Overview

The M2400S is a highly versatile and cost effective outdoor point-to-multipoint solution for wireless broadband service providers' enterprise connectivity applications. The M2400S delivers 5 Mbps over the air, and operates in the 2.4 GHz license free ISM band. Each radio includes an integrated dual polarized (horizontal and vertical) antenna, as well as a connector for the attachment of an external antenna, such as a Yagi or an omni style antenna.

Note: If you are going to install an external antenna, refer to the M2400S Professional Installation Guide. Contact Technical Support for access to the Professional Installation Guide.

The M2400S system consists of two types of radios: Access Points (APs) and Subscriber Units (SUs). Up to 126 subscriber units can be supported by a single AP, which acts as a hub in a star configuration. The AP delivers wireless broadband service (Ethernet connectivity) to one or more SUs according to a proprietary adaptive dynamic polling algorithm called SMARTPolling™. Network operators can co-locate multiple APs at a single cell site, thus increasing the aggregate throughput available at each wireless point-of-presence (POP).

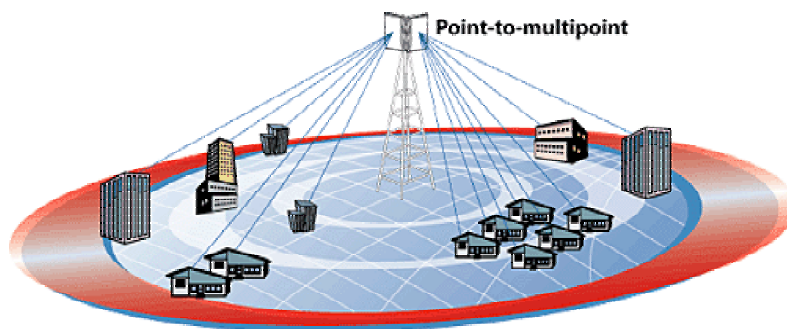

Figure 1: Typical Deployment

The AP typically resides at the center of the point-to-multipoint (PMP) network. It performs all management functions, including the allocation of bandwidth for all associated SUs. The M2400S AP provides a host of comprehensive tools and functions.

The M2400S system is classified as a Layer 2 multi-point bridge, thus all forms of Ethernet traffic will pass seamlessly over the system. There is no limitation on the number of IP addresses or hardware devices to which an individual subscriber unit may be connected.

Authentication of Subscriber Units is performed using a secure proprietary method, which is based on the MAC address of the Subscriber Unit. In order to establish a wireless link the MAC address of the SU must be present in the Access Point's Subscriber Unit Database (SUDB).

Both APs and SUs are IP addressable and can be managed remotely across the network. Users can manage the radios using the telnet command line interface or the graphical HTTP browser interface. The M2400S also provides remote firmware upgrade capability utilizing TFTP. APs include a full featured SNMP agent for the monitoring and controlling of both APs and SUs via SNMP.

The M2400S radios are powered using "power-over-Ethernet" for ease and low-cost installation. A single Cat-5 cable carries both Ethernet and DC power to the radio.

Both APs and SUs feature a handy "site survey" tool to check for interference, as well as RSSI tools for optimizing antenna positioning. The M2400S also features variable receiver threshold, full power control, dual polarized antennas, and various link diagnostic tools.

SmartPolling™ & Bandwidth Throttling

One of the major advantages of the M2400S system is the ability of the AP to handle multiple SU connections and share the 5 Mbps data throughput efficiently. Bandwidth allocation is managed by the AP's SMARTPolling™ algorithm according to provisioning rules set up by the system administrator. The AP polls each SU in a round robin format to determine if the SU has data to transfer. The SU only transmits the data "upstream" to the AP when the AP gives authorization via a "transmit grant." The SU passes every "downstream" data packet from the AP and identifies packets intended for it. In order for an SU to communicate with an AP, the system administrator must first add the MAC address and ID number of the SU to the SUDB in the AP. The SMARTPolling™ algorithm will poll active SUs more often, thus making the most efficient use of the 5 Mbps bandwidth. Several other parameters are considered in the Smart Polling™ algorithm, including upstream/downstream committed information rate (CIR), upstream/downstream maximum information rate (MIR), and Priority Setting.

Each of the above parameters is set in the AP by the system administrator and cannot be controlled at the SU. These parameters will be covered in greater detail later in this text.

When power is first applied to a properly installed SU, it will scan all available channels listening for a grant from an AP that has a matching Base ID and the SU's MAC in the its SUDB. The SU will then stop on that channel and respond to the AP using maximum RF power. Before the AP can add the SU to the polling list, it must authenticate the SU by verifying the MAC address and performing a ranging operation to the SU. Upon successfully locating and ranging the SU, the AP will then add the SU to the normal polling list. Once the AP is regularly polling the SU, the SU is said to be "associated" to the AP.

Once associated, the AP will send a command to the SU to adjust the SU's RF transmit power based on the Target RSSI parameter set in the AP. This process is referred to as "power leveling."

System operators may limit allowable bandwidth to specific customers utilizing the built-in CIR and MIR settings (measured in kbps) for each SU.

Auto-retransmit Feature (ARQ)

The M2400S features ARQ or "Automatic Repeat Request," which is the ability to correct for missing or corrupted packets of data by requesting the sending radio to re-transmit the data. Both the AP and SU units implement a form of ARQ known as "ARQ with Selected Repeat." The use of ARQ is especially important in areas of high interference. The ARQ feature can be turned on or off.

Section 2 Hardware Overview

This section provides detail about each radio in the M2400S family. Each radio in the M2400S family includes a built-in, electronically switchable, dual-polarized antenna, as well as a reverse polarity SMA connector for the attachment of an external antenna. For ease of installation, all units are designed for outdoor installation and powered by power-over-Ethernet (POE). The M2400S Access Point and Subscriber Units provide channels of operation within the 2400 MHz ISM band, which spans from 2400 MHz to 2483 MHz. Default channel spacing is 10 MHz, allowing for 8 non-overlapping channels.

M2400S AP and SU Hardware Components

Each radio comes equipped with, a power-over-Ethernet (PoE) J-Box, an AC adapter, and mounting hardware.

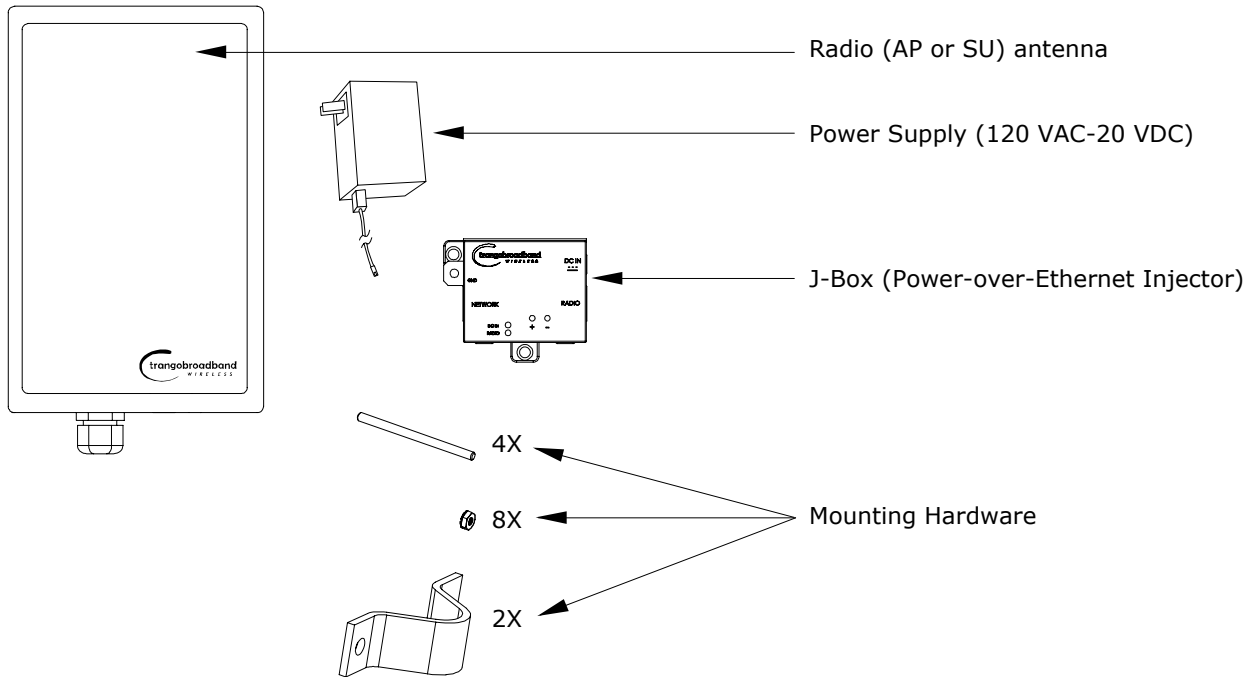

Figure 2: Basic Components of an M2400S Radio

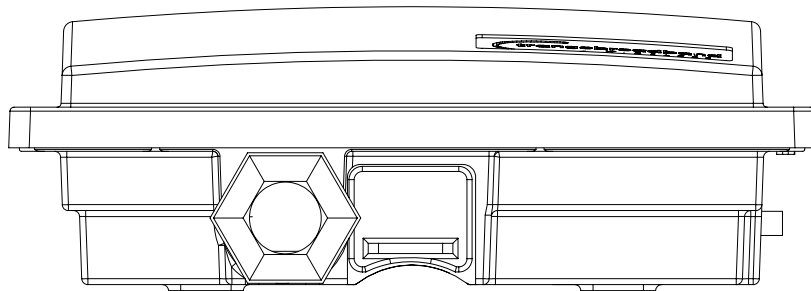

Figure 3: Bottom of Radio

At the bottom of the M2400S are two access ports: a twist-on weatherproof cable port for RJ-45 Ethernet (and PoE), and a translucent access cover plug over the unit's diagnostic LEDs and reset button. The LEDs will be discussed later in this text.

The radio's model number, FCC ID, MAC ID, and Serial # are located on the backside of the radio.

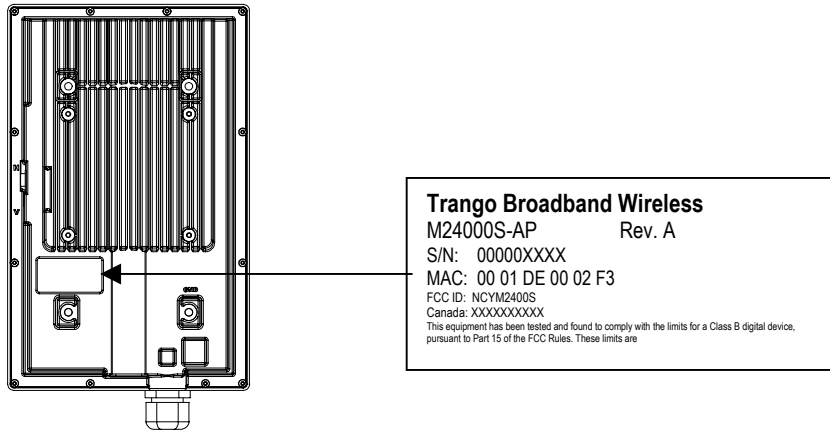

Figure 4: Back of Radio

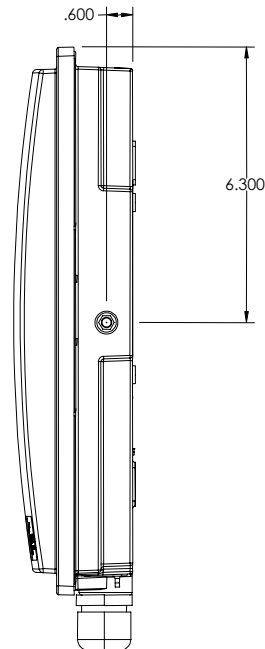

Figure 5: Side of Radio & Location of Reverse Polarity SMA Connector

Section 3 Getting Started

This section explains how to power your radios, establish TCP/IP connectivity to the radios, as well as how to access the HTTP browser and the command line interfaces.

Connections and Power

Connection and powering of radios is the same for APs and SUs.

- Connect a Cat-5 (straight through) Ethernet cable (we recommend shielded twisted pair) between the Radio port of the J-box and the RJ-45 connector on the radio. Note: this cable will carry power-over-Ethernet (PoE).
- NETWORK port connection is as follows:
 If connecting to a COMPUTER, use a Cross-Over Ethernet cable from the NETWORK port of the J-box to the computer's Ethernet port.
 If connecting to a HUB, SWITCH, or ROUTER, use a Straight-Thru cable.
- Plug the AC adapter into an AC outlet.
- Use Ground Lug to ground PoE device and shielded CAT5.
- Use voltmeter contacts to check line voltage (can be done with or without load).

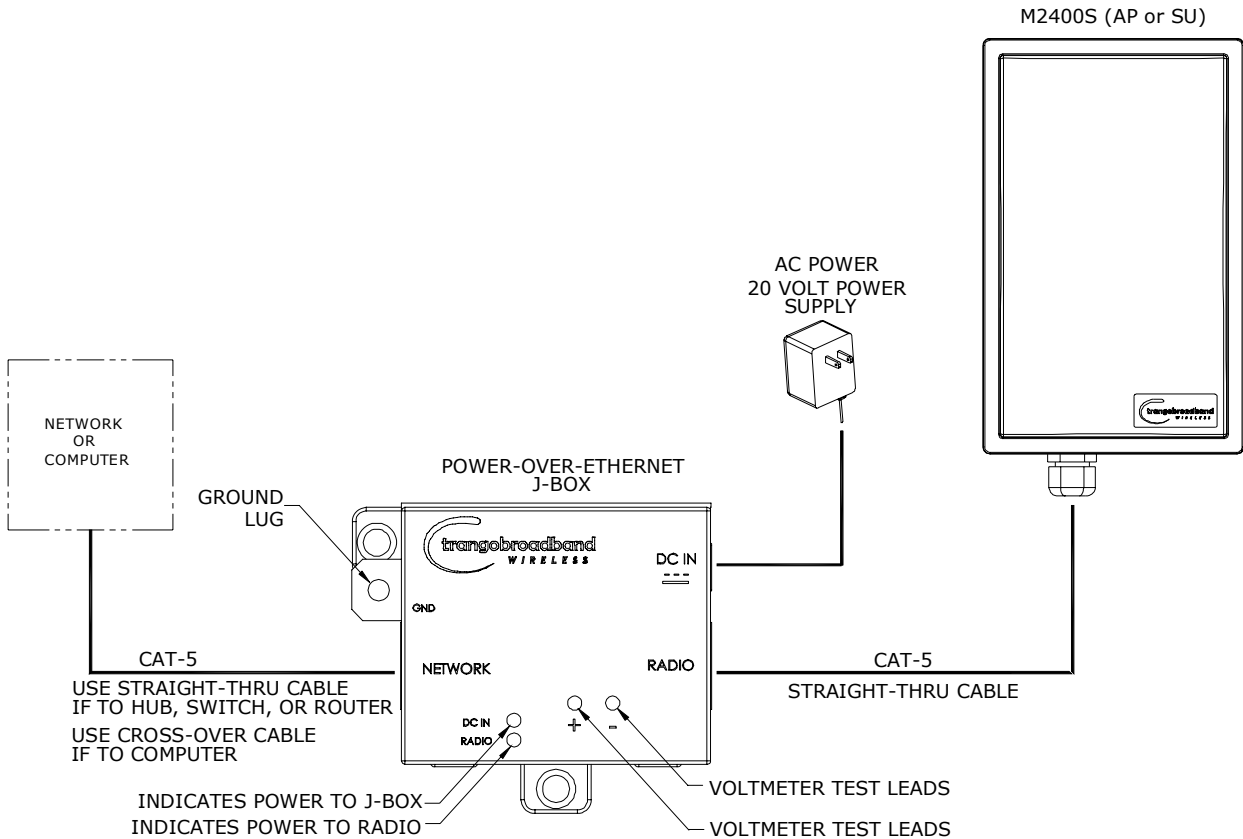

Figure 6: Wiring Diagram

Both green LEDs on the J-box should be lit, indicating power is present at the J-box as well as the radio. You are now ready to configure the radio via the Ethernet port.

Radio Management Concepts

Proper connections to the radios and careful IP/routing & planning will enable the network administrator to access and manage the radios remotely over the network via TCP/IP. Radio management over TCP/IP can be performed from computers connected to the Ethernet side of each radio. Computers connected to the AP can manage the SU over their wireless connection. Likewise, computers connected to the SU can manage the AP, provided that switch 7 (TCP/IP access to AP from SU) is enabled on the AP. Switches will be covered later in this text.

Opmode

To fully understand radio management for the M2400S system, it is important to be familiar with the concept of operation mode or “Opmode.”

APs and SUs can be in one of two Opmodes (“ON” or “OFF”). When in Opmode “OFF”, the AP is not transmitting and is not attempting to associate with any SUs. Alternatively, when in Opmode “ON,” the radio is transmitting and attempting to become associated.

Several functions, such as the site survey function and the SU RSSI function, can only be performed while the radio is in a particular Opmode. See Appendix D (Command Set Reference) for a complete listing of commands, and the appropriate Opmode for each command.

Switch Settings

M2400S firmware includes several “switches,” which are used to set certain operational parameters of the radios. Switch settings can be changed via the HTTP browser interface or the Command Line Interface. For purposes of radio TCP/IP management, the following four switches are important:

Switch 2 (SU) - TCP/IP access to SU from the AP’s side of network requires that the SU’s switch 2 (SW 2 – TCP/IP for AP) be ON. Default setting for SW 2 (from factory) is ON.

Switch 5 (AP and SU) – In order to utilize the radio’s HTTP Browser interface, switch 5 (SW 5 – Enable HTTP) must be ON. Default setting for SW 5 (from factory) is ON.

Switch 6 (SU) - TCP/IP access from Ethernet port of SU while in Opmode “ON,” requires that switch 6 (SW 6 – TCP/IP Service for Ethernet Port) be ON. Default setting for SW 6 (from factory) is ON. If SW 6 is OFF, TCP/IP access to SU from it’s Ethernet port is possible only if SU’s Opmode is “OFF.”

Switch 7 (AP) – TCP/IP access to AP from SU’s side of network requires that the AP’s switch 7 (SW 7 – TCP/IP for SU) be ON. Default setting for SW 7 (from factory) is ON.

Passwords

In order to log into an M2400S radio (either through telnet or through the web browser interface), the user must know the IP address and password. Both AP’s and SU’s feature two levels of passwords: Read Write (RW) and Read Only (RO). Be sure to change both passwords (RW and RO) prior to deployment of your radios on a live network. Passwords can be changed using the *password ro* and *password rw* command in either the CLI interface or in the command console of the browser interface.

Reset Button

Pressing the reset button will reset the radio’s IP address and password back to factory defaults.

Default IP (192.168.100.100) **Default Password** (trango)

Browser Interface

The M2400S (both AP and SU) features a convenient and easy-to-use web based configuration and management tool. No additional software is needed on your computer other than a web browser. Most functions can be performed using the browser interface, although several functions can only be performed using command line interface (CLI). The browser interface also includes a “command console” page that allows the user to enter most CLI commands without leaving the browser interface.

To use the browser interface, the following must be present:

- An Ethernet connection between a PC and the radio
- Ethernet PC connection with IP/subnet that is routable to the radio
- SW 5 ON (default)
- A web browser on the PC (i.e. Microsoft Internet Explorer)

Getting Started

In order to use the browser interface, simply connect the radio to a PC and type the radio's IP address (default IP address=**192.168.100.100**) into the web browser (i.e. Microsoft Internet Explorer). This will bring up the Login page.

NOTE: Login pages for AP and SU are similar.

Browser Interface Login Page

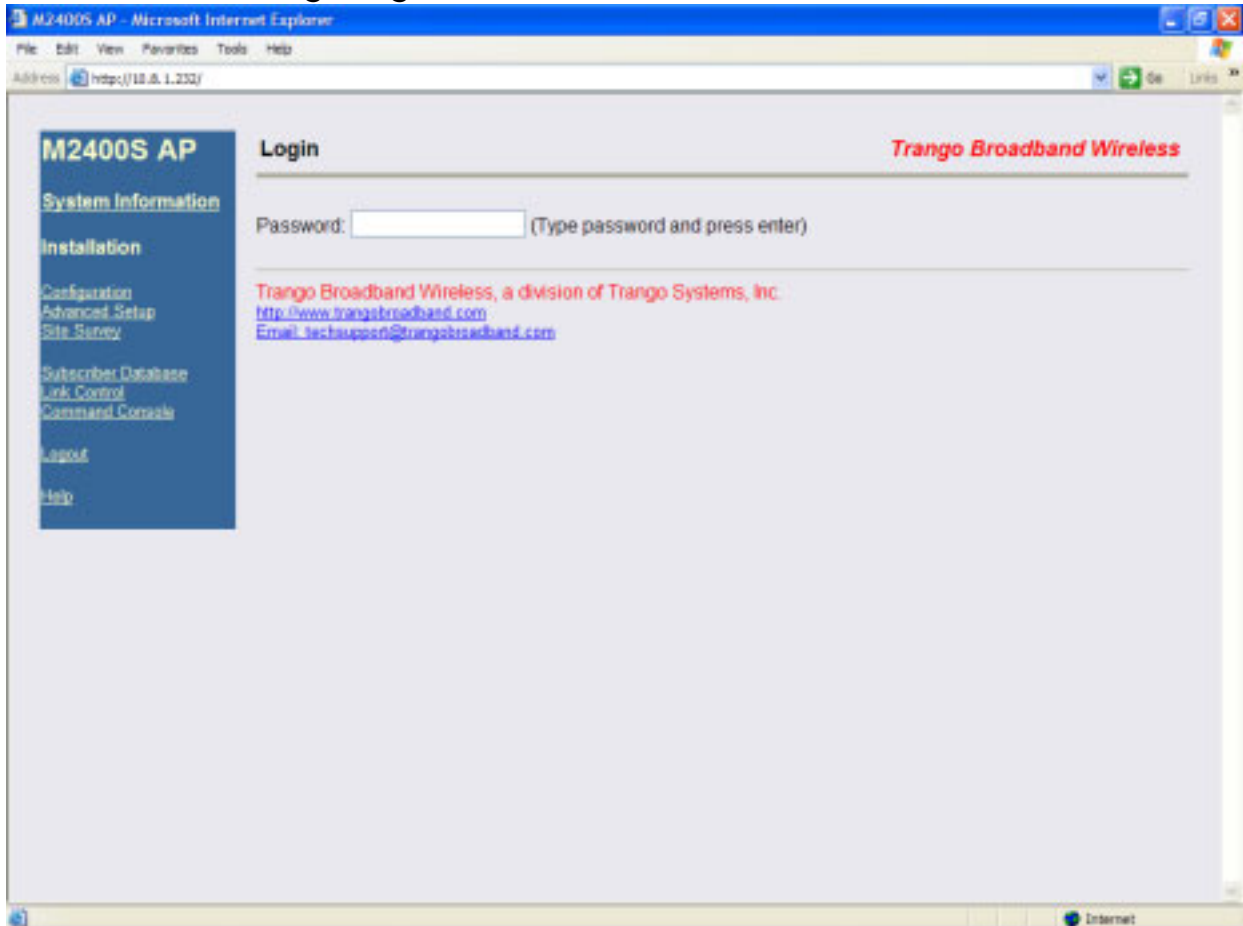

Type the password (default **trango**) and continue. This will bring up the radio's system information page.

Web Browser System Information Page

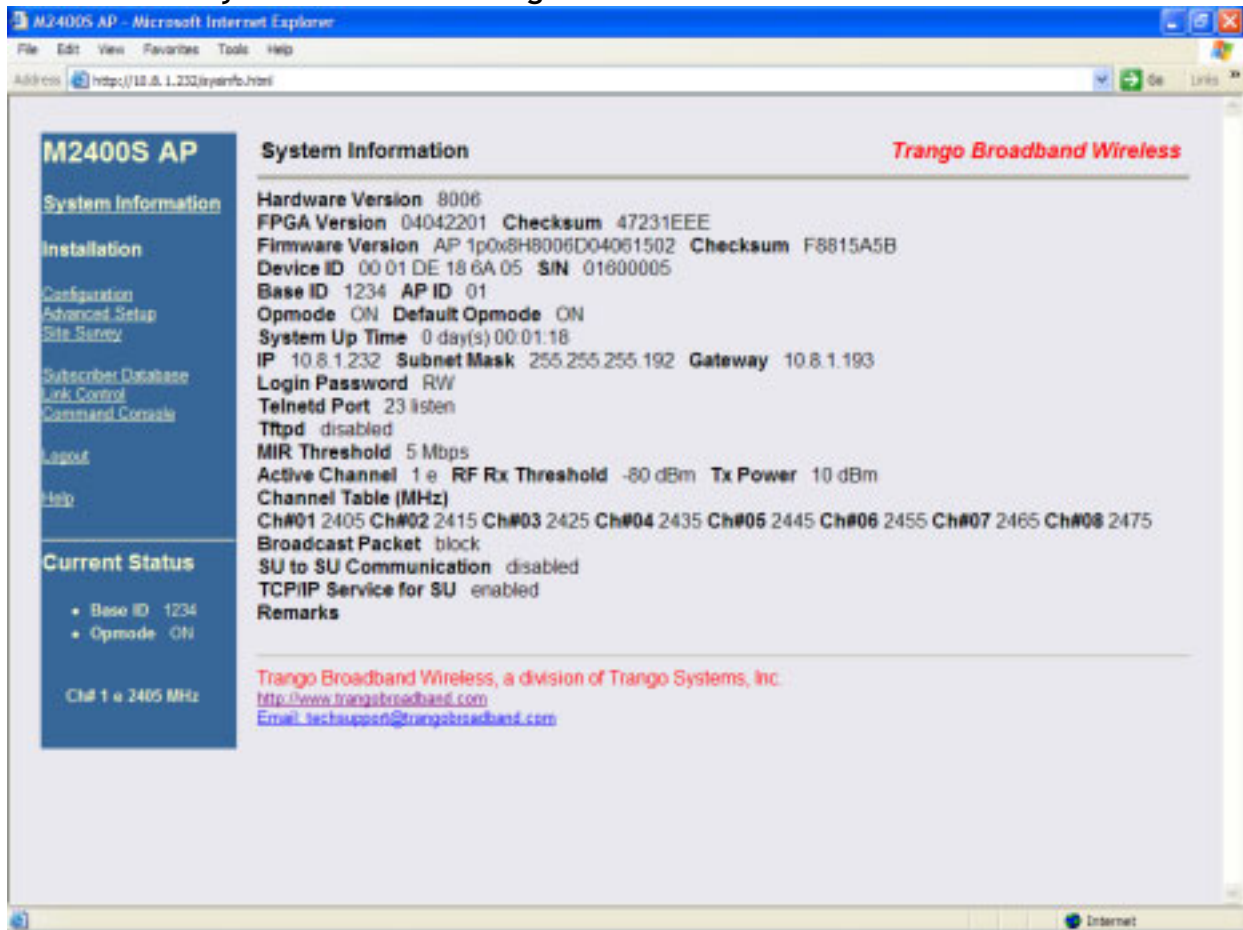

 Note: System Information screen for the Subscriber Unit is similar and is covered in detail later in this text.

Primary Features and Pages of the Browser Interface

Navigation Column: Each page features a navigation column, which runs along the left-hand side of the page. The model number of the radio is listed at the top of the navigation column. On the bottom of the navigation column is the Current Status of the radio that includes its Base ID, current Opmode, channel, antenna selection, and frequency.

The navigation column also features links to each of the following pages:

System Information: This page shows most of the basic configuration parameters of the radio. It is the first page shown after login.

Configuration: The essential parameters, such as Base ID, IP, subnet, gateway, channel, and antenna polarization are set here.

Advanced Setup: The advanced RF parameters, such as transmit power, receiver threshold control, and channel center frequencies are set here.

Site Survey: With Opmode “OFF,” the user can conduct a spectrum analysis using this page.

Subscriber Database: This is the page for defining which SUs can associate to the AP.

Link Control: This page shows which SUs are associated. This page also provides several tools for evaluating the quality of the wireless link.

Command Console: From this page, the user can run any console command that is not interactive (i.e. *ipconfig*) or time sensitive (*su linktest*). For a complete list of console commands, type *help* or *?* in the entry field.

Logout: This link will end the current browser session with the radio.

Help: The Browser Interface features useful [Help](#) pages which explain all listed parameters. To access the help pages click on the [Help](#) link.

Command Line Interface

Although most radio functions can be managed via the browser interface, the command line interface (CLI) provides slightly more functionality and is usually the management tool of choice for experienced users. The CLI can be accessed through Telnet.

Telnet

Open a command prompt (DOS) session on your PC. Open a telnet session by typing:

telnet [ip address of radio]

All Trango radios are pre-configured at the factory with a default IP address of 192.168.100.100. The factory default password is **trango**. Once you connect to the radio you will be greeted with current hardware and firmware information and prompted for a password. Type in the read-write (RW) password and press enter.

Example:

```
C:>telnet 192.168.100.100
Welcome to Trango Broadband Wireless M2400S-AP 1p0X21H0006D04081903
Password:
#>
```

To terminate a CLI session (Telnet or Serial) type the command *logout*.

 Note: Type *help* or *?* for a listing of all CLI commands. Type *help <command>* for the syntax of a particular command.

Example (to view a list of all commands that start with su)

```
#> ? su
su [all | <suid, 1..126>]
su info <suid, 1..126>
su linktest <suid, 1..126>
su password <suid|all> <rw|ro> <new password> <new password>
su ping <suid, 1..126>
su reboot <suid|all>
su sw <suid|all> <sw#, 0..7> <on | off>
su testrflink <suid, 1..126> <r>
su testrflink <all> <r>
sudb add <suid, 1..126> <pr|re> <device id,hex>
sudb cirmir <<suid>|all> <cir dn> <cir up> <mir dn> <mir up>
sudb defaultcirmir [<cir dn> <cir up> <mir dn> <mir up>]
sudb delete <<suid>|all>
sudb dload
sudb gid <<suid>|all> <0..15>
sudb view
survey <time, 1..10 sec> <antenna, h|v|e>
```

#>

 NOTE: The majority of the CLI commands will be covered throughout this text as well as in Appendix A – Command Set Reference.

Troubleshooting

If you cannot telnet into the radio or open a browser session, check cable connections, ensure proper use of cross-over vs. straight-through cable, and ensure PC's subnet is routable to radio's IP address. If you still cannot access the radio's management interfaces, consult the troubleshooting guide, which is available at www.trangobroadband.com in the Technical Support area of the website.

Section 4 Basic Configuration via Browser Interface

This section describes a few more basic concepts and how to establish a basic wireless link between AP and SU using the Browser (HTTP) Interface. This section is written to address only the most basic steps in establishing a link in the lab, or a bench-top environment. It is highly recommended to read the other sections of this manual to gain an understanding of all important configuration parameters and procedures prior to deploying any wireless equipment.

In this section you will:

- Learn about AP and SU Basic Configuration Screens and Parameters
- Populate AP's Subscriber Unit Data Base (SUDB) with at least one SU
- Configure Other Basic AP Parameters
- Configure Basic SU Parameters
- Establish a Wireless Link
- Evaluate Link Quality

The M2400S uses the concept of “association” to indicate that the AP and SU's are communicating. If all parameters are properly set, the AP will begin actively searching for the SU's in its SUDB. Once an active SU is detected, the authentication and association process will begin.

Essentials in Establishing a Wireless Link with M2400S Series Radios

- Base ID in AP and SU must match
- MAC Address of SU must be entered into the AP's SUDB
- SU must be set to “autoscan” all channels (switch 1), or be fixed on same channel as AP.
- AP must be in Opmode “ON”
- SU must be in Opmode “ON”
- Adequate signal strength must be received at each radio

If all of these parameters are met, the wireless link will automatically establish itself and Ethernet traffic will begin to pass between the radios.

 Note: This section utilizes the Browser Interface as the configuration tool. For the equivalent procedure using CLI commands, see Section 5.

Configuring the AP Subscriber Unit Database (SUDB)

Prior to establishing a wireless link, the user must configure the SUDB in the AP with each SU's MAC address and related settings. The SUDB includes information about each SU. Click on the [Subscriber Database](#) page to add, modify, or delete SUs. The key information for each SU includes the following:

SU ID:	User definable Subscriber Unit ID (1...126)
TYPE:	PR (Priority) or REG (Regular). Priority SUs are polled more frequently than regular SUs. Priority SUs will generally respond to the AP with less latency than regular SUs.
Group:	SU to SU Group # (1..F in hex) for SU to SU communications within the same sector. Note: This SU to SU feature allows interconnectivity between multiple SUs in the same sector, without the need for a router. Only SUs with same SU to SU group # may communicate with each another. If you do not want the SUs to communicate with each other, choose N/A for SU to SU group. In order to use SU to SU communication, AP switch #3 must be ON. Default setting for switch #3 is OFF.

 Note: SUs using SU to SU communication must be on the same subnet.

CIR UP:	Committed Information Rate from SU to AP. Minimum upstream rate (measured in Kbps) at which the SU will attempt to deliver bandwidth to the AP. Maximum setting is 5200.
---------	--

- CIR DOWN: Committed Information Rate from AP to SU. Minimum downstream rate (measured in Kbps) at which the AP will attempt to deliver bandwidth to that SU. Maximum setting is 5200.
- MIR UP: Maximum Information Rate from SU to AP. Maximum upstream rate (measured in Kbps) at which the SU will attempt to deliver bandwidth to the AP. Maximum setting is 5200.
- MIR DOWN: Maximum Information Rate from AP to SU. Maximum rate (measured in Kbps) at which the AP will attempt to deliver bandwidth to that SU. Maximum setting is 5200.
- DEVICE ID: MAC address of the SU.

Creating an SU in the SUDB

1. Connect to the AP (see Getting Started) and open the [Subscriber Database](#) page.

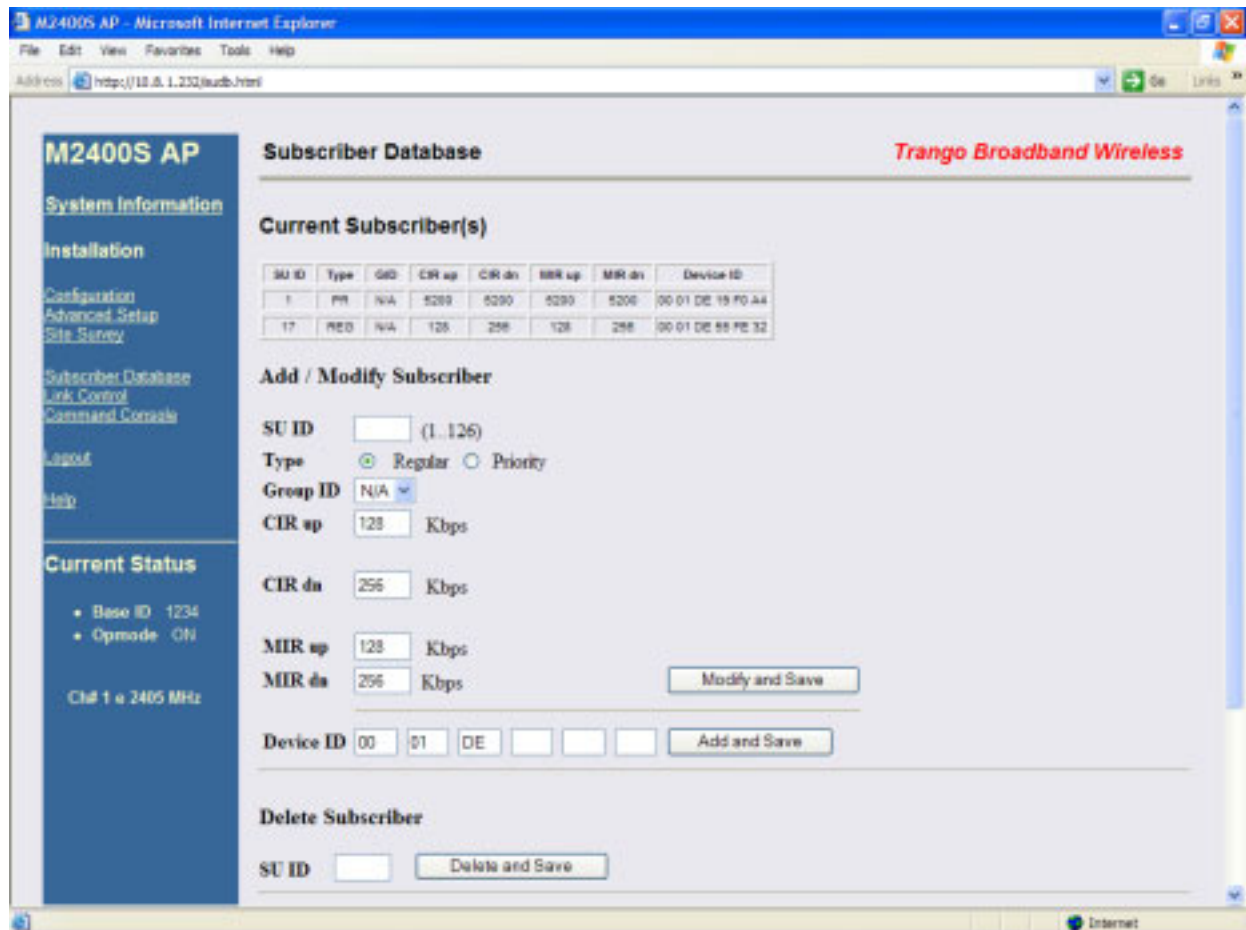

2. Enter the SU ID (range 1 – 126).
3. Select either PRIORITY or REGULAR.
4. If the SU will be part of an SU to SU group, enter the SU to SU group number.
5. CIR up (SU to AP Committed Information Rate) is the minimum upstream bandwidth for the SU in Kbps.
6. CIR dn (AP to SU Committed Information Rate) is the minimum downstream bandwidth for the SU in Kbps.
7. MIR up (SU to AP Maximum Information Rate) is the maximum upstream bandwidth for the SU in Kbps.
8. MIR dn (AP to SU Maximum Information Rate) is the maximum downstream bandwidth for the SU in Kbps.

9. Enter the Device ID (MAC Address of the SU).
10. Save and Activate changes.



Important! Always remember to Save and Activate changes, otherwise the SUDB will revert back to its previous state after a power cycle or reboot.



Important! SUs using SU to SU communication must be on the same subnet.

Configure Other Basic AP Parameters

In addition to setting up the SU in the SUDB, the following settings from the AP's [Configuration](#) page must be set (or left at default).

Base ID: Base station ID, consisting of four user definable alphanumeric characters. Input of Base ID will be in the format of xxxx. Where x is any character from the set : { 0..9; a..z; A..Z; '!@#\$\$%^&*()_+[\]\<>,./?' } . The Base ID is typically assigned to a single AP or a group of APs at a particular cell site. The Base ID in the AP must match the Base ID in the SU in order for a link to be established. This parameter can only be changed while in Opmode "OFF."

AP ID: User definable AP ID (00-FF). Default is last two digits of MAC ID. Once authenticated, the AP will automatically assign its AP ID to the SU. This parameter can only be changed while in Opmode "OFF."

IP Address, Subnet Mask, and Gateway:

The IP address used on the radio is for management purposes only. Since this is a layer-II device, these parameters do not play a role in establishing the wireless link.

Default Opmode:

Will initiate Operation Mode of the radio after a power cycle or reboot. When the radio enters Opmode "ON," it will be transmitting. When the radio enters Opmode "OFF," it will not be transmitting. The radio can be put into Opmode "OFF" regardless of its default Opmode by telnetting into the radio within the first 30 seconds after a power cycle or reboot.

Active Channel/Polarization:

Is the current channel and antenna polarization of the unit when in Opmode "ON."

To configure the AP's other basic settings, complete the following steps:

1. Connect to the AP (see Getting Started) and open the [Configuration](#) page.

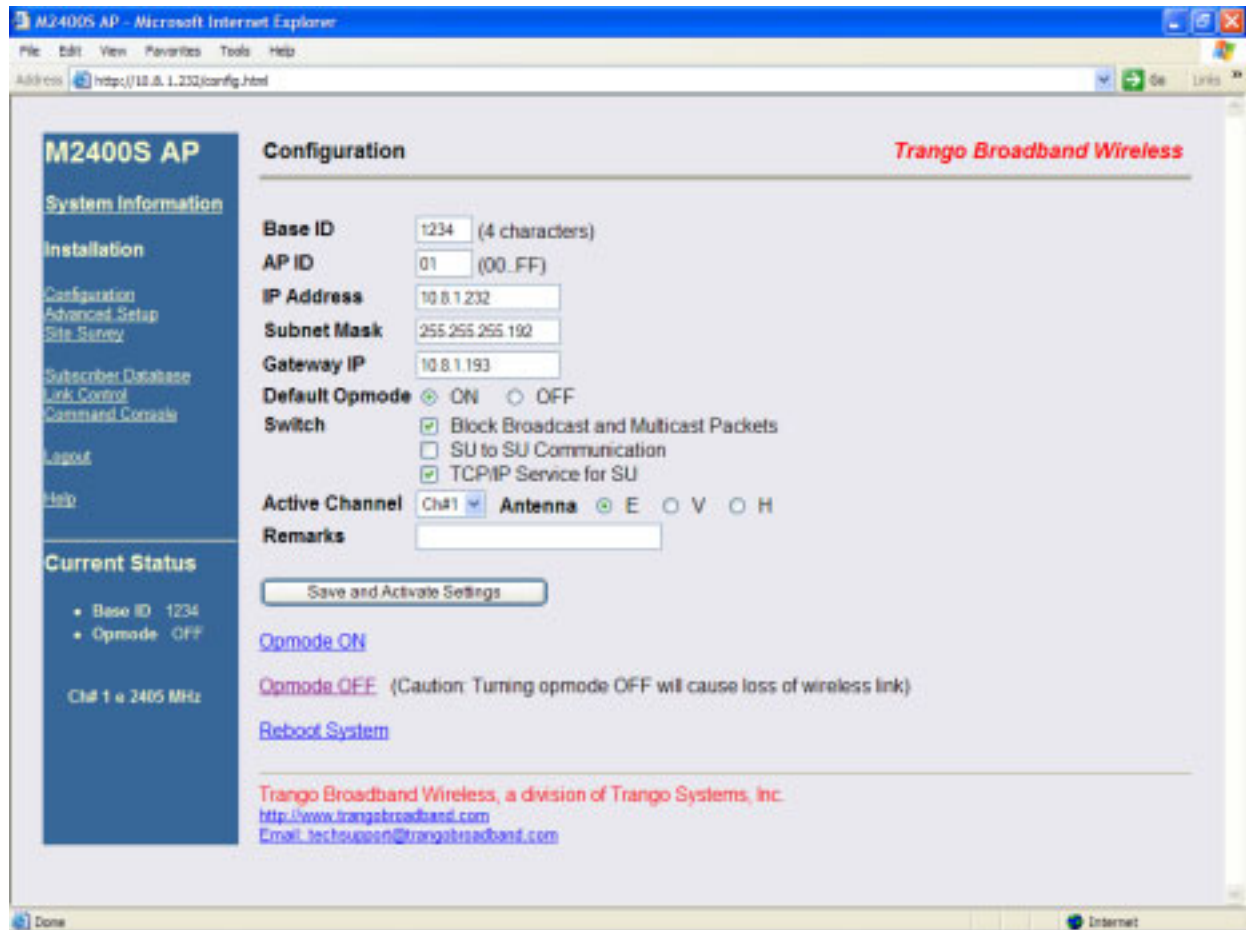

2. Set Base ID, or choose default base ID of 0000 (must match the SU).
3. Set AP ID (00-FF HEX).
4. Set IP, Subnet, and Gateway, or leave at default settings. Keep in mind if you change the IP Settings of the radio you will loose your HTTP session when you save and activate.
5. Choose Active Channel (1-8).
6. Choose Antenna Polarization (H or V) or choose E for an external antenna.
7. Ensure default Opmode is "ON."
8. Save and Activate Settings.
9. If this is the first SU to be added to the SUDB, reboot the AP.

After reboot, the AP will automatically enter its default Opmode, after approximately 40 seconds. At this time it will begin actively searching for all SUs in its SUDB. Once an active SU is detected, the authentication and association process will begin.

Configure Basic SU Parameters

In order to establish a working link, the Base ID in the SU must match the Base ID of the AP.

SU Basic Setup:

1. Connect to the SU (see Getting Started) and open the [Configuration](#) page.

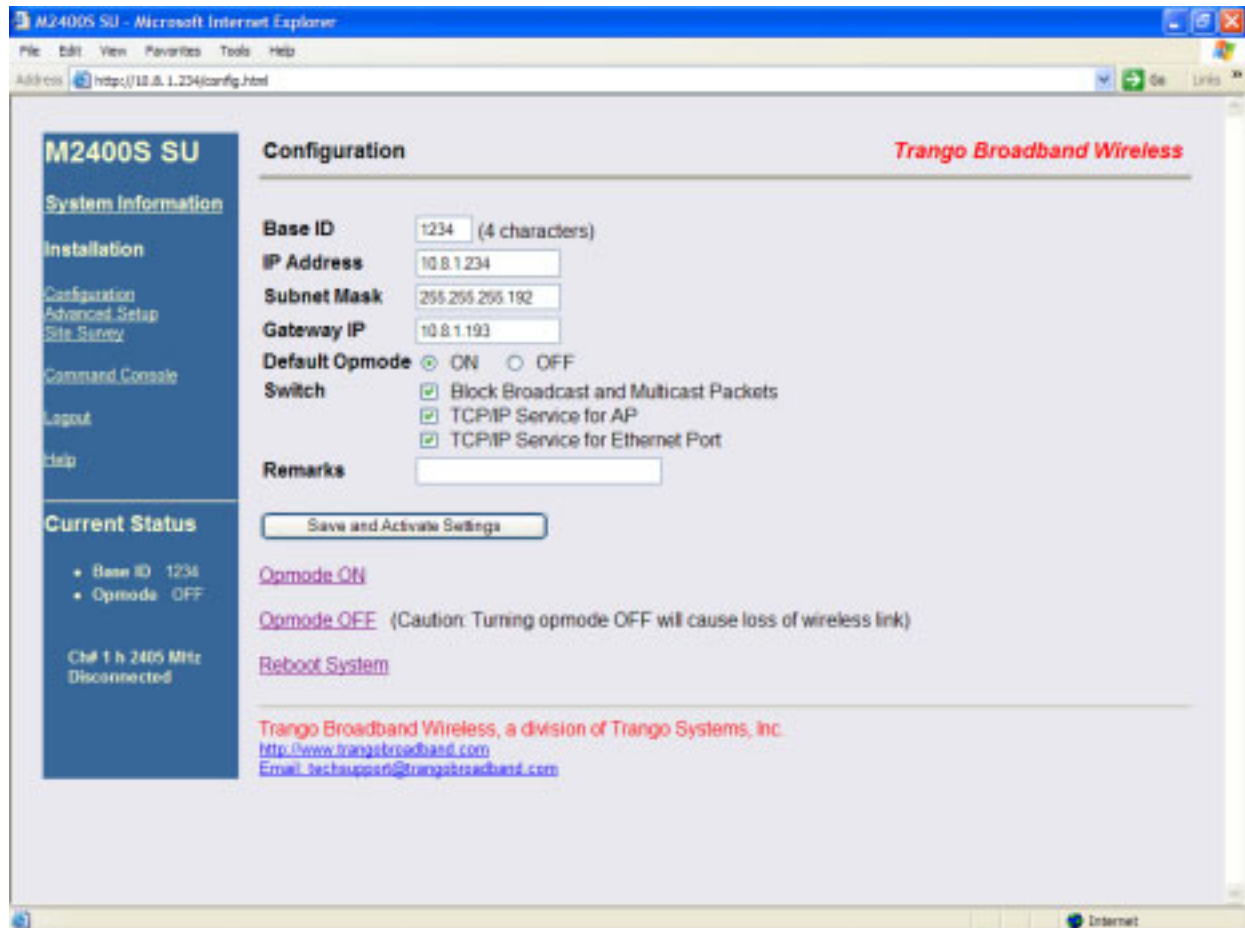

2. Set Base ID (must match the AP).
3. Set IP, subnet, and gateway, or leave at default settings. Keep in mind if you change the IP Settings of the radio you will lose your HTTP session when you save and activate.
4. Ensure default Opmode is "ON."
5. Save and Activate Settings.
6. If Opmode is "OFF," click [Opmode ON](#).

At this point, if all parameters have been set correctly and the radios are within range, a wireless link between the AP and SU will automatically become established. Once this occurs the SU will be in "associated" status.

Allow approximately 60 seconds for the radios to complete the boot-up cycle and to associate. If the AP is busy servicing many SUs, the association process may take slightly longer.

LED Summary

At this point it is useful to learn about the various LEDs that can be found on the bottom of the radio. These LEDs can assist the user in determining radio and link status.

RSSI LEDs (YELLOW) - In all modes except "Survey," the unit's four yellow LEDs indicate the level of RF signal being received from a valid AP.

Yellow LED 1 (rightmost): On when RSSI \geq -85 dBm
Yellow LED 2 : On when RSSI \geq -75 dBm
Yellow LED 3 : On when RSSI \geq -65 dBm
Yellow LED 4 (leftmost): On when RSSI \geq -55 dBm.

In addition, these 4 LEDs will flash once to indicate the 'factory reset' button has been activated.

ASSOCIATION LED (GREEN)

Blinking once every second in Opmode "OFF" (AP and SU).

Twice per second Opmode "ON" and scanning for an AP (SU Only).

Solid after unit is associated with an AP (SU Only).

Solid after unit is in Opmode "ON" (AP Only).

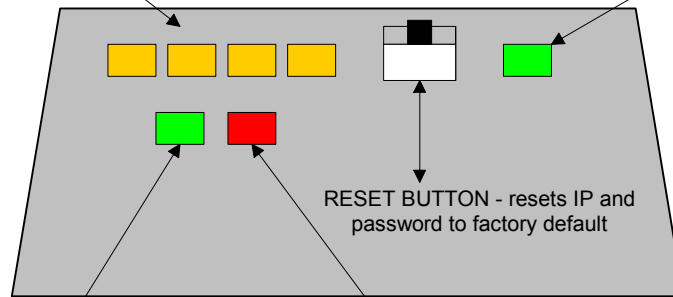

10/100 Link LED (GREEN) - Illuminated when link speed is negotiated at 100 BaseT. It is off when link speed is 10 BaseT or not connected.

ACT LED (RED) - Ethernet Activity Light

LED / RESET BUTTON WINDOW

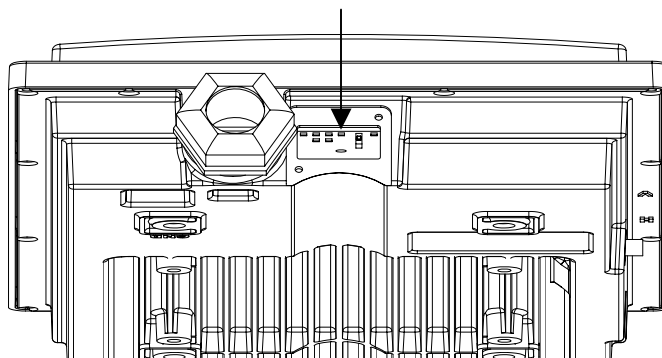
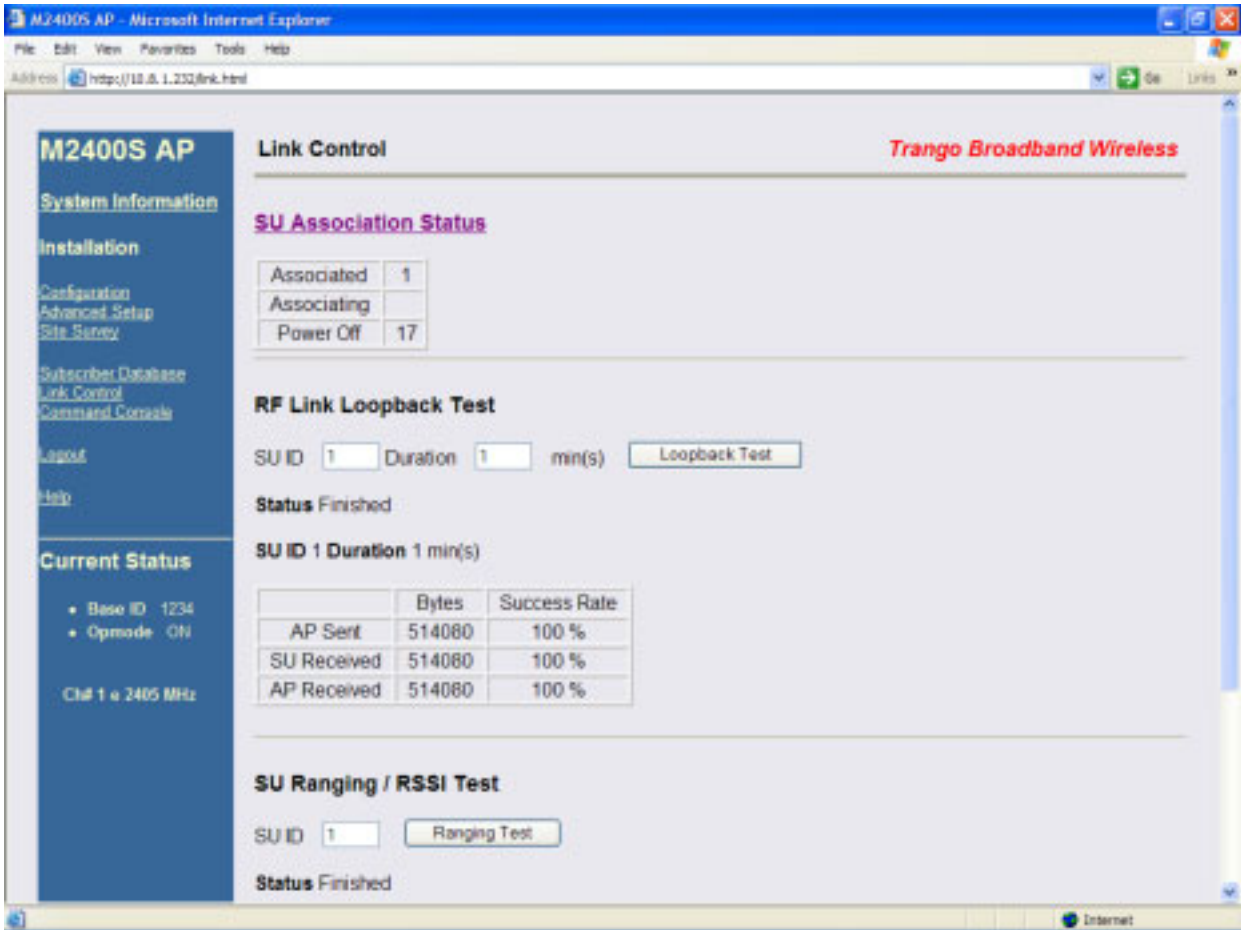

Figure 7: LED Summary

Link Control Page

The radio's firmware includes several useful tools to assist in determining which SUs are associated, and the quality of each link. One method for verifying link quality is by using the [Link Control](#) page.



On this page the user can immediately see which SUs are currently associated. In the page shown, SU ID# 1 is associated, and SU ID# 17 is not. Consider "Power Off" status synonymous with "not associated."

RF Link Loopback Test

The RF Link Loopback Test is one of the built-in tools for evaluating the quality of the wireless link. Specify an SU ID and time in minutes to conduct the test. The test is prioritized, so it will take precedence over all other traffic. 1600 byte packets are sent and received between the SU and AP at 50 millisecond intervals over the time specified.

RF Link Loopback Test

SU ID Duration min(s)

Status Finished

SU ID 41 Duration 1 min(s)

	Bytes	Success Rate
AP Sent	514080	100 %
SU Received	514080	100 %
AP Received	514080	100 %

SU Ranging Test

This test reports the SUs distance from AP in miles, received signal strength for uplink and downlink,

and SU TX Power. Use a link budget calculator to analyze results. Significant differences between calculated and actual values could indicate alignment or LOS issues!

Distance	RSSI from SU	RSSI from AP	SU Tx Power
0.0 mi	-81 dB	-80 dB	26 dBm

Advanced Setup Page

The advanced set up page includes several important parameters including RF TX Power, RF RX Threshold, target RSSI from SU (AP only), and Channel Table.

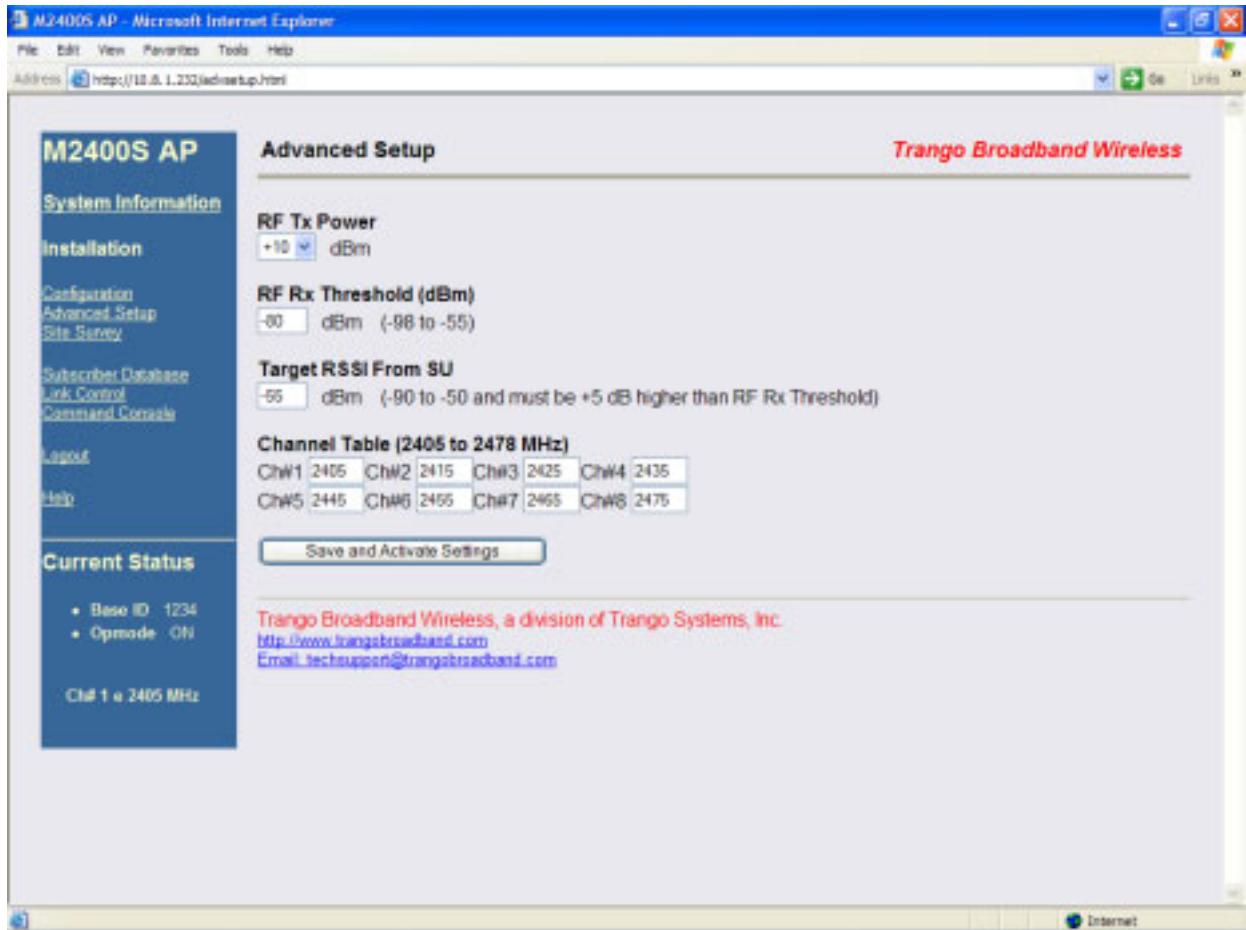

- RF TX Power:** Sets the conducted RF power output of the radio. Highest allowable setting is +23 dBm. Lowest setting is +10 dBm. This value does not include antenna gain.
- RF RX Threshold:** Sets the receive threshold of the radio. The radio will not process signals received below this level, so it is very useful for interference mitigation. For a smaller radius of operation, use a higher threshold (-75 is higher than -80).
- Target RSSI from SU:** Used by the powerleveling process to automatically adjust the RF output power level of all SUs in a sector so the signal strength from each SU, as measured at the AP, will be roughly equal.

Channel Table: Assigns channel numbers to actual frequencies of operation. Default settings allow the largest number of channels (8) within the band, while still maintaining a 10 MHz channel spacing.

Other Key Parameters

This section describes the remainder of the parameters listed on the System Information page. Most of these parameters are the same for both APs and SUs.

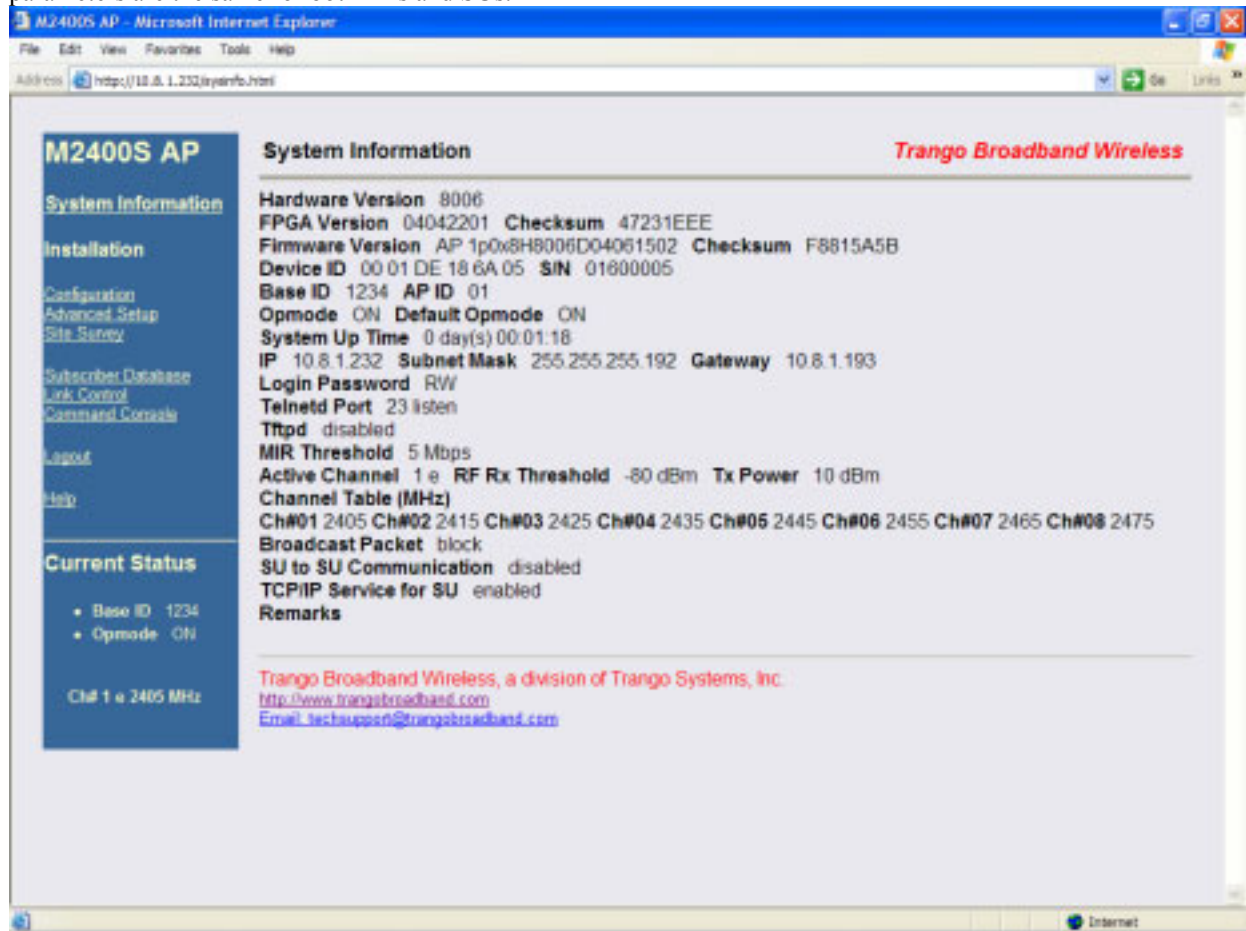

Hardware Version: Hardware version is factory-set and can not be changed by the user.

FPGA Version: Low level field programmable gate array firmware currently loaded on the radio. Normally the FPGA firmware will not require upgrading.

Firmware Version: Main firmware. In this example, the version part of the string is 1p0 (v1.0), the hardware code is H8006, and the remainder of the string is a date code.

Device ID: MAC address of the radio.

S/N: Serial number of the radio.

Telnetd Port: User changeable telnet port of radio.

TFTPD: Current status of TFTP daemon. Used for uploading firmware.

MIR Threshold: Shown in Mbps (0.5) Maximum Information Rate (MIR) Threshold. The MIR Threshold is the aggregate throughput of the AP at which the AP will start to enforce CIR rules for the SUs.

Active Channel: The channel currently being used by the radio.

RFRX Threshold: Sets the receive threshold of the radio. The radio will not process signals received below this level, so it is very useful for interference mitigation. For a smaller radius of operation use a higher threshold (-65 is higher than -70).

Broadcast Packet: This software switch (0) enables/disables the blocking of Ethernet control packets, except ICMP and ARP, to reduce the amount of unnecessary overhead introduced into the wireless link.

SU to SU Communication: If enabled (switch 3), SUs with matching SU to SU groups (except group 0) can communicate in peer-to-peer mode through the AP without the need of a router behind the AP. SUs using SU to SU communication must be on the same subnet.

TCP/IP Service for SU: If enabled, the AP can be accessed via TCP/IP (Telnet or HTTP) from the SU side of the network via the wireless link.

Remarks: User definable radio information (i.e. customer name, address of installation, etc). A maximum of 28 characters can be stored.

Site Survey Page

The Site Survey page provides a useful tool for detecting and measuring interference. The radio must be in Opmode "OFF" in order to use this feature.

Enter the number of minutes desired for the survey, and select the polarization H, V, or E (for an external antenna). Click "Start Survey." A survey of the default 8 channels will be performed. Results are reported in dBm per channel as average and peak. A channel is reported to be "Clear" if the peak and average are below the RF RX Threshold by more than 8 dB.

The screenshot shows the 'M2400S AP' web interface. On the left is a navigation menu with options like 'System Information', 'Installation', 'Configuration', 'Subscriber Database', 'Logout', and 'Help'. The main content area is titled 'Site Survey' and includes a 'Start Survey' button. Below the button, it shows 'Status Finished' and 'Antenna e Duration 1 min(s)'. A table displays the results of the survey for 8 channels, with columns for Channel, Avg dBm, Peak dBm, and Clear status.

Channel	Avg dBm	Peak dBm	Clear
1	-99	-94	yes
2	-99	-94	yes
3	-99	-94	yes
4	-93	-90	yes
5	-69	-69	no
6	-34	-33	no
7	-68	-68	no
8	-99	-94	yes

At the bottom of the page, there is contact information for Trango Broadband Wireless, a division of Trango Systems, Inc., including a website URL and an email address.

Section 5 Basic Configuration via CLI

This section covers how to utilize the radio's CLI interface to establish a working wireless link.

In this section, the most common settings using the CLI are discussed. Topics include:

- Access Point Basic Settings
- Subscriber Unit Database Settings
- Subscriber Unit Basic Settings

See Appendix A – Command Set Reference, for a complete listing of CLI commands.

See the “Getting Started” section for a description of how to access the radio using the telnet interface.

Access Point Basic Settings

After logging onto an AP or SU, it is good practice to type the *sysinfo* command to see the radio's basic system information. Example (Access Point):

```
#> sysinfo
[Hardware Version] 8006
[FPGA Version] 04042201 [Checksum] 47231EEE
[Firmware Version] AP 1p0x8H8006D04061502 [Checksum] F8815A5B
[Device ID] 00 01 DE 18 6A 05 [S/N] 01600005
[Base ID] 1234 [AP ID] 01
[System Up Time] 0 day(s) 01:37:29
[Opmode] on [Default Opmode] on
[IP] 10.8.1.232 [Subnet Mask] 255.255.255.192 [Gateway] 10.8.1.193
[Login Password] RW
[Httpd Port] 80 [Httpd Status] listen
[Telnetd Port] 23 [Telnetd Status] connected (10.8.0.60,1454)
[Tftpd] disabled
[RF Tx Power] 10 dBm
[RF Rx Threshold] -80 dBm
[MIR Threshold] 5 Mbps
[Ch#01] 2405 Mhz [Ch#02] 2415 Mhz [Ch#03] 2425 Mhz [Ch#04] 2435 Mhz
[Ch#05] 2445 Mhz [Ch#06] 2455 Mhz [Ch#07] 2465 Mhz [Ch#08] 2475 Mhz
[Default Channel] 1 e [Active Channel] 1 e
[Broadcast Packet] block [SU to SU] off [TCP/IP for SU] on
[Remarks]

[RF Rx] 0 kbps [RF Tx] 0 kbps [Eth Rx] 3 kbps [Eth Tx] 5 kbps
```

Many of these parameters can be changed by the user. A description of each of these changeable parameters, along with the related command is shown in the table below.



Important! When changing settings, it is usually necessary to type the *save ss* command in order to update the radio's flash memory. If you do not type the *save ss* command, the setting will be lost the next time the radio is rebooted or power cycled.

AP SYSTEM INFORMATION PARAMETERS AND RELATED COMMANDS		
AP Parameter	Description	Related CLI Command
Device ID	MAC Address of AP	N/A
Base ID	Specifies the cell or cluster to which the AP belongs. Base ID must match in AP and SU in order to establish a wireless link.	<i>set baseid <baseid></i> Example: #>set baseid aa12

AP SYSTEM INFORMATION PARAMETERS AND RELATED COMMANDS		
AP Parameter	Description	Related CLI Command
AP ID	This parameter provides a unique number for each AP. If Target AP is specified on SU, the SU can only authenticate with the specified AP. The default AP ID is the last two bytes of the MAC address.	set apid <apid> (00-FF in HEX) Example: #>set apid 33
Opmode	Current Opmode of the radio.	opmode on y This sets the radio to Opmode “ON.” If the radio is accessed via the Ethernet port within the first 30 seconds after reboot/power cycle, the Opmode will default to “OFF.”
Default Opmode	Determines the Opmode (“ON” or “OFF”) of the radio after reboot/power cycle. When this parameter is set to “ON,” the radio will progress into Opmode “ON” automatically after a reboot/power cycle.	set defaultopmode <on or off> Example: #>set defaultopmode on
Opmode Start	Determines the amount of time the radio will remain in Opmode “OFF” after reboot/power cycle before progressing to the default Opmode.	set defaultopmode on [<time (sec)>] Example: #>set defaultopmode on 60
IP Subnet Gateway	IP, Subnet, and Gateway address of the radio.	ipconfig [<new ip> <new subnet mask> <new gateway>] Example: #>ipconfig 10.1.1.2 255.0.0.0 10.1.1.1
TFTPD Status	TFTPD status (on or off). TFTPD should be turned on to import a file into the radio (such as new firmware). Default is off. TFTPD will revert to Off after rebooting.	tftpd [<on off>] Example: #>tftpd on

AP SYSTEM INFORMATION PARAMETERS AND RELATED COMMANDS		
AP Parameter	Description	Related CLI Command
MIR Threshold (Kbps)	User specified MIR Threshold. To specify total throughput level that the AP will serve only CIR (committed information rate) to associated SUs. When MIR Threshold is disabled, the AP will serve MIR for all its SUs. When MIR Threshold is activated, and the network traffic exceeds the MIR Threshold, the AP will only serve CIR for all its SUs. When MIR Threshold is activated, and the network traffic does NOT exceed the MIR Threshold, the AP will still serve MIR for all its SUs.	<i>mirth</i> [<0..3, Mbps>] Example: #>mirth 2
Active Channel	Current RF channel	<i>freq</i> [<ch#> <v h>] Example: #>freq 3 This command will change the channel of the AP to 3.
Antenna	Current antenna selection: (h)horizontal, (v)vertical, (e)external	<i>antenna</i> [<v h e>]
RF RX Threshold	Specifies the receiver sensitivity of the AP. It is a powerful tool when the radio is in a noisy environment. AP will block out any signal received which is below the RF Rx threshold. Separate settings exist for both ISM and UNII bands.	<i>rfrxth</i> [<-90 -85 -80 -75 -70 -65>] example: #>rfrxth -70
RF TX Power	Current transmit power of the AP not including antenna gain.	<i>power</i> <set> <min max>[<dBm>] Example: #>power set 10
Channel Table	Assigned frequencies to channels. All channels may be re-assigned as desired by the administrator.	<i>freq writechannel</i> [<ch#> <freq>] Example: #>freq writechannel 3 910 This command will change channel 3 to 910 Mhz.
Broadcast Packet Filter	This software switch (0) enables/disables the blocking of Ethernet control packets, except ICMP and ARP, to reduce the amount of unnecessary overhead introduced to the wireless link.	<i>sw 0</i> [<on/off>] (default is on) Example: #>sw 0 on note: All switch settings (0-7) are set using the <i>sw #</i> [<on/off>] command.
SU to SU	This software switch (3) enables/disables the SU to SU feature. When SU to SU is turned on, multiple SU's within	<i>sw 3</i> [<on/off>] (default is off) Example: #>sw 3 on

AP SYSTEM INFORMATION PARAMETERS AND RELATED COMMANDS		
AP Parameter	Description	Related CLI Command
	the same sector (meaning associated to that AP) can communicate with each other, provided they have the same SU2SU group number.	
TCP/IP for SU	This software switch (7) when on, allows users on the SU side of the network to telnet or HTTP into the AP.	sw 7 [<i><on off></i>] (default is on) Example: #>sw 7 off
Remarks	User definable radio information (i.e. customer name, address of installation, and so on). A maximum of 28 characters can be stored.	remarks [<i><remarks></i>] Example: #>remarks 123 Elm Street

Subscriber Unit Database Settings

Once you are familiar with the basic system information presented above, you are ready to add one or more SUs to the SUDB. There are five basic commands related to the SUDB: *sudb add*, *sudb cirmir*, *sudb defaultcirmir*, *sudb view*, and *save sudb*.

Adding an SU

You will need to know the following information to add an SU to the database:

1. MAC ID of the SU (printed on the back of the SU).
2. Polling priority: either PRIORITY or REGULAR.

 Note: SUs designated as PRIORITY will get polled more often by the AP.

To add an SU to the SUDB, use the following command and syntax:

```
sudb add <suid> <pr|reg> <device id>
suid: SU ID
pr: priority user
reg: regular user
<device id>: xx xx xx xx xx xx in hexadecimal (this is the MAC address of the SU)
```

Example:
#>sudb add 5 pr F3 3C 50 67 89 D4

In this example, SU ID 5 was added as a Priority SU. The MAC ID of that SU is F3 3C 50 67 89 D4.

 Note: You can add up to 126 entries in the SUDB

CIR / MIR Commands

The default CIR/MIR setting is 5000 Kbps for upstream and downstream values.

To change SU's CIR/MIR settings, use the following command:
sudb cirmir <suid | all> <cir dn> <cir up> <mir dn> <mir up>

Example:
#>sudb cirmir 5 128 256 5000 5000

In this example, SU #5's CIR downstream is set to 128 and CIR upstream is set to 256. MIR upstream and downstream are set to 5000.

To change the default CIR/MIR values, use the following command:

```
sudb defaultcirmir <default cir dn> <default cir up> <default mir dn> <default mir up>
```

Example:

```
#>sudb defaultcirmir 256 256 512 512
```

To view the entries in the SUDB, type the command **sudb view**.

To save the changes you have made to the SUDB, type **save sudb**

Other important SUDB related commands are **sudb delete**, **sudb gid**, and **sudb modify**. See Appendix A for descriptions of these commands.



Important! After updating the SUDB, type the command **save sudb** to save the SUDB. If you do not save the SUDB file will revert back to its previous state after power cycle or reboot.



Important! SUs using SU to SU communication must be on the same subnet.

Subscriber Unit Basic Settings

Once logged into the SU, you can receive a comprehensive snapshot of the system's configuration info and status by typing the command **sysinfo**.

```
#> sysinfo
[Hardware Version] 0006
[FPGA Version] 04042201 [Checksum] 47231EEE
[Firmware Version] SU 1p0x8H0006D04061502 [Checksum] 6DDF232C
[Device ID] 00 01 DE 19 F0 A4 [S/N] 01700004
[Base ID] 1234 [AP ID] 01 [SU ID] 1
[System Up Time] 0 day(s) 05:14:51
[Opmode] on [Default Opmode] on
[IP] 10.8.1.234 [Subnet Mask] 255.255.255.192 [Gateway] 10.8.1.193
[Login Password] RW
[Httpd Port] 80 [Httpd Status] listen
[Telnetd Port] 23 [Telnetd Status] connected (10.8.0.60,1738)
[Tftpd] disabled
[RF Tx Power] 22 dBm
[RF Rx Threshold] -98 dBm
[Ch#01] 2405 Mhz [Ch#02] 2415 Mhz [Ch#03] 2425 Mhz [Ch#04] 2435 Mhz
[Ch#05] 2445 Mhz [Ch#06] 2455 Mhz [Ch#07] 2465 Mhz [Ch#08] 2475 Mhz
[Default Channel] 1 h [Active Channel] 1 v [Associated] Y
[Broadcast Packet] block [Auto Scan AP] on [TCP/IP for AP] on [TCP/IP for Local
Eth] on
[Remarks]
```

```
[RF Rx] 3 kbps [RF Tx] 2 kbps [Eth Rx] 0 kbps [Eth Tx] 0 kbps
[ARQ RF Tx Retry] 0 [ARQ RF Tx Retry Maxed Out] 0
```

Many of these parameters can be changed by the user. A description of each of these changeable parameters, along with the related command, is shown in the table below.



Important! When changing settings, it is usually necessary to type the *save ss* command in order to update the radio's flash memory. If you do not type the *save ss* command, the setting will be lost the next time the radio is rebooted or power cycled.

SU SYSTEM INFORMATION PARAMETERS AND RELATED COMMANDS		
SU Parameter	Description	Related CLI Command
Device ID	MAC Address of the SU	N/A
Base ID	Specifies the cell or cluster to which the SU belongs.	<i>set baseid <baseid></i> Example: #>Set baseid aa12
Target AP	If unique AP ID selected, the SU can only associate with the specified AP. If ALL is selected, the SU can associate with any AP with a matching BASE ID.	<i>targetap <apid></i> Examples: #>targetap 33 #>targetap all
Opmode	Current Opmode of radio.	<i>opmode on y</i> - set Opmode to "ON." (note: "y" is necessary if default Opmode is "OFF.") <i>opmode off</i> – set Opmode to "OFF."
Default Opmode	Determines the Opmode ("ON" or "OFF") of the radio after reboot/power cycle. When this parameter is set to "ON," the radio will progress into Opmode "ON" automatically after reboot/power cycle.	<i>set defaultopmode <on or off></i> Example: #>set defaultopmode on
IP Subnet Gateway	IP, Subnet, and Gateway address of radio.	<i>ipconfig [<new ip> <new subnet mask> <new gateway>]</i> Example: #>ipconfig 10.1.1.3 255.0.0.0 10.1.1.1
TFTPD	TFTPD status (on or off). TFTPD should be turned on to import a file into the radio (such as new firmware). Default is off. TFTPD will revert to off after reboot/power cycle.	<i>tftpd [<on off>]</i> Example: #>tftpd on
RF TX Power	Current transmit power of the SU not including antenna gain. This is controlled by the AP.	Informational Parameter – can not be manually changed by user.
Active Channel	Shows the channel used in the current association, and "Associated" or "Disconnected" depending on the association status.	If Autoscan AP (SW 1) is on, the active channel (and antenna selection) will be set once the SU scans and begins the association process with an AP. If Autoscan AP is off, the active channel is set by the user, using the <i>freq</i> command. <i>freq [<ch#> <v h>]</i> Example:

SU SYSTEM INFORMATION PARAMETERS AND RELATED COMMANDS		
SU Parameter	Description	Related CLI Command
		#>freq 3 This command will change the channel of the AP to 3. Use the antenna command to select an antenna polarization. antenna [<i><h v e></i>]
Broadcast Packet Filter	This software switch (0) enables/disables the blocking of Ethernet control packets, except ICMP and ARP, to reduce the amount of unnecessary overhead introduced into the wireless link. Default setting is ON.	sw 0 [<i><on off></i>] Example: #>sw 0 on
AP Autoscan	This software switch (1) is to turn AP autoscan on or off.	sw 1 [<i><on off></i>] (default is on)
TCP/IP for AP	This software switch (2) when on, allows users at the AP side of the network to telnet or HTTP into the SU.	sw 2 [<i><on off></i>] (default is on) Example: #>sw 2 off
TCP/IP for Local Ethernet Port	This software switch (6) when on, allows users on the wired side of the SU to telnet or HTTP into the SU regardless of the Opmode.	sw 6 [<i><on off></i>] (default is on)
Remarks	User definable radio information (i.e. customer name, address of installation, and so on). A maximum of 28 characters can be stored.	remarks [<i><remarks></i>] Example: #>remarks 678 Oak Ave
Counters: RF TX RF RX Eth TX Eth RX	This is an average of wired and wireless, transmitted and received, traffic in kilobits per second.	Informational Parameter

Section 6 Mounting Hardware

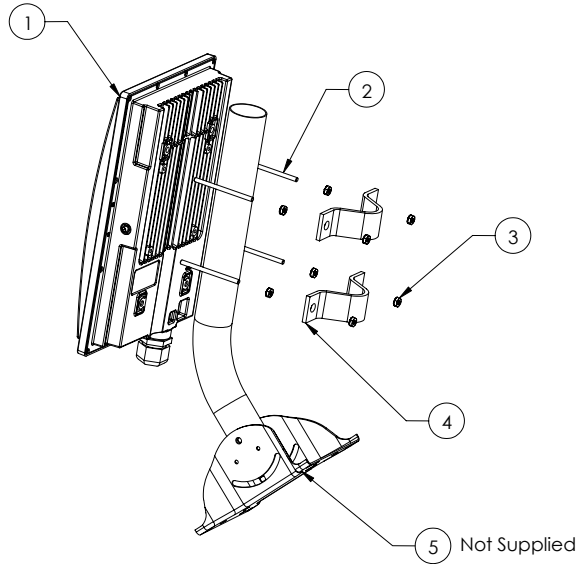

ITEM NO.	PART NUMBER	QTY.
1	Radio	1
2	5/16 x 3" Threaded Rod	4
3	5/16 Keps Nut	8
4	"V" Bracket	2
5	Mono Pod Mount (Not Supplied)	1

Figure 8: M2400S Mounting Hardware Assembly

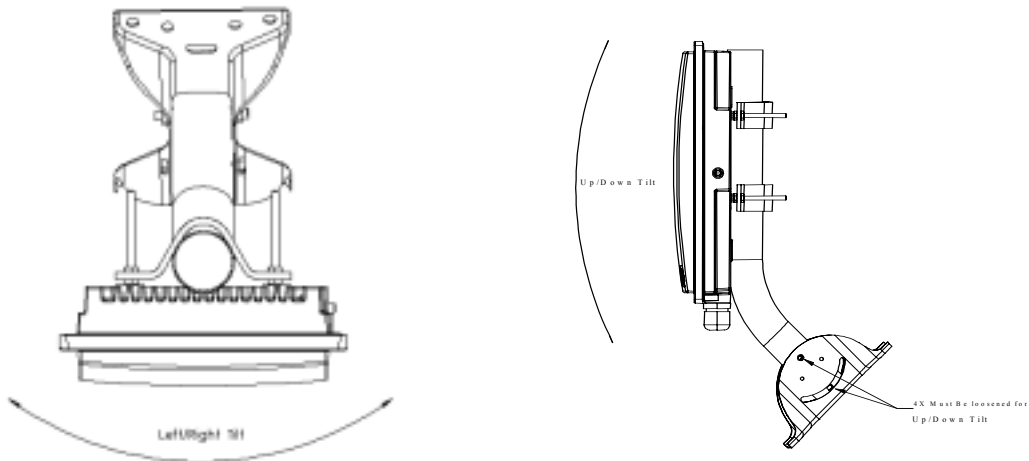

Figure 9: Articulation for M2400S with Mono Pod Mount (not supplied)

Cabling and Grounding Considerations

Grounding Example

Proper mounting of the radio includes consideration for grounding. Please note that if the radio is attached to a metal pole that is earth-grounded, no other grounding is necessary. If the radio is not earth-grounded via the mounting bracket, you must attach a grounding wire to the grounding stud on the back of the radio as in the adjacent diagram.

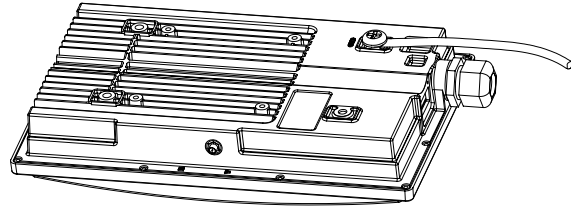

Figure 10: Grounding of Radio

Installation Notes

Access to the radio's RJ-45 Port and LED status lights are purposely located at the bottom of the radio to minimize the risk of water intrusion. **Do not mount the radio upside down.**

The J-Box is not a weatherized device and must be located either indoors or in a weather-protected cabinet.

Shielded twisted pair Cat-5 cable is recommended for all installations unless cable is placed in metal conduit.

The shield within the Cat-5 cable does not need to be grounded if the radio itself is grounded.

It is important to consider that most Cat-5 cable will deteriorate over time if exposed to the weather (especially direct sunlight). Conduit (metal or PVC) is recommended to protect the cable.



Important! The Ethernet port compression washer should be loosely tightened around the Cat-5 cable to allow pressure equalization within the radio enclosure. Leave approximately 1 mm around the Cat-5.

It is important to provide strain relief and drip loop for STP Cat-5 cables. Do not mount the radio upside down.

Section 7 Deployment

Once you are familiar with the basic operation of the radios, you are ready for deployment in the field. The deployment process consists of the following steps:

- Site Selection
- Site Survey
- Channel Planning
- SU Antenna Alignment
- Link Management Commands

Site Selection

Proper site selection for your AP will help ensure a successful deployment. Site selection will depend on a wide variety of factors, but from the radio's performance standpoint consider the following:

- Path from AP to SU should provide as few obstructions as possible. It is advisable to place the AP as high as possible on a tall building or tower.
- Ethernet cable is limited to 300 feet from Ethernet device (router, switch) to radio.
- Radios require grounding for optimal performance.
- AP provides sector coverage of 60 degrees azimuth and 18 degrees elevation
- Consider nearby sources of interference that could degrade performance of radio. Mount radios as far from sources of interference as possible.
- Perform a site survey to determine noise levels and the relative clarity of channels at the chosen installation location.

Site Survey

Both the AP and SU provide a powerful on-board site survey tool. This tool will tell you if there is interference present in the 2.4 GHz ISM band.

Command: `survey <time> <antenna>`

In order to use the survey command, the radio must be in Opmode "OFF." The survey can be performed for up to 10 seconds per channel (incrementing by 5 MHz). The test can be run for either the (h) horizontal polarization, (v) vertical polarization, or (e) external antenna.

Prior to performing the site survey, place the radio in the installation spot, and aim the radio in the desired direction.

The results of the test will provide you with a listing of each channel in the band, the average signal received, and the maximum signal received during the survey period.

In general you will be looking for frequencies with interference signal strength of -85 dBm or lower. If interference is present on various channels, it is recommended that you chose clean channels or alternate polarizations for your deployment. If it is not possible to use a clean channel/polarization combination, there are various methods available to mitigate the affects of interference. These methods include the use of the RFRX THRESHOLD settings, the use of external shields, and/or external narrower beam antennas.

Site Survey Example:

#> survey 2 v

Press [space] then [enter] to stop

```

2350 MHz    peak -94 dBm avg -99 dBm
2355 MHz    peak -94 dBm avg -99 dBm
2360 MHz    peak -94 dBm avg -99 dBm
2365 MHz    peak -94 dBm avg -99 dBm
2370 MHz    peak -94 dBm avg -99 dBm
2375 MHz    peak -94 dBm avg -99 dBm
2380 MHz    peak -94 dBm avg -99 dBm
2385 MHz    peak -94 dBm avg -99 dBm
2390 MHz    peak -94 dBm avg -99 dBm
2395 MHz    peak -94 dBm avg -99 dBm
2400 MHz    peak -94 dBm avg -99 dBm
2405 MHz Ch 1 peak -91 dBm avg -92 dBm
2410 MHz    peak -69 dBm avg -75 dBm **
2415 MHz Ch 2 peak -61 dBm avg -66 dBm ***
2420 MHz    peak -70 dBm avg -76 dBm *
2425 MHz Ch 3 peak -90 dBm avg -92 dBm
2430 MHz    peak -94 dBm avg -99 dBm
2435 MHz Ch 4 peak -94 dBm avg -99 dBm
2440 MHz    peak -94 dBm avg -99 dBm
2445 MHz Ch 5 peak -94 dBm avg -99 dBm
2450 MHz    peak -94 dBm avg -99 dBm
2455 MHz Ch 6 peak -94 dBm avg -99 dBm
2460 MHz    peak -94 dBm avg -99 dBm
2465 MHz Ch 7 peak -94 dBm avg -99 dBm
2470 MHz    peak -94 dBm avg -99 dBm
2475 MHz Ch 8 peak -94 dBm avg -99 dBm
2480 MHz    peak -94 dBm avg -99 dBm
2485 MHz    peak -94 dBm avg -99 dBm
2490 MHz    peak -94 dBm avg -99 dBm
2495 MHz    peak -94 dBm avg -99 dBm
2500 MHz    peak -94 dBm avg -99 dBm
2505 MHz    peak -94 dBm avg -99 dBm
2510 MHz    peak -94 dBm avg -99 dBm
2515 MHz    peak -94 dBm avg -99 dBm
2520 MHz    peak -94 dBm avg -99 dBm
2525 MHz    peak -94 dBm avg -99 dBm
2530 MHz    peak -94 dBm avg -99 dBm
2535 MHz    peak -94 dBm avg -99 dBm
2540 MHz    peak -94 dBm avg -99 dBm
2545 MHz    peak -94 dBm avg -99 dBm
2550 MHz    peak -94 dBm avg -99 dBm
#>

```

In this example of a survey on the vertical polarization for 2 seconds for each 5 MHz portion of spectrum, the largest amount of energy is detected at frequency 2415 MHz.

The asterisks (****) indicate the highest **avg** amount of energy detected and corresponds to the number of yellow colored LEDs lit.

Note: The survey also covers spectrum outside of the operational range of the radio.

Once the site survey is completed you are ready to install your radios. It is recommended that APs be installed first. The reason for this is that the SU has a built-in RSSI tool that will help you properly aim the SU toward the AP to achieve the maximum signal strength.

AP Search and SU Antenna Alignment

Once the AP is installed and aligned in the correct general direction, it is time to install the SU. The hardware installation of the SU is identical to the AP, including considerations for line-of-sight, cable distances, cable type, weather sealing, and grounding.

Once the SU is installed and aimed in the general direction of the AP it is time to perform an RSSI (relative signal strength indicator) test to determine the signal strength from the AP. Now you can precisely align the SU antenna for maximum signal strength.

Although it is possible to rely upon the Subscriber Unit's LEDs for alignment, more precise RSSI readings are available from the command *rssi*.

In conjunction with the *rssi* command, it is also useful to perform the *apsearch* command. This command will tell you which AP is providing an adequate signal at the location of the SU.

AP Search

1. Ensure AP is in Opmode "ON."
2. Run the *apsearch* command to verify which AP is providing the strongest signal strength.

```
#> apsearch
```

Press [space] then [enter] to stop

```
1 2405 Hz 1234 DE 18 6A 05 [H: -55 dBm] [V: -75 dBm] [E: -99 dBm]
2 2415 Hz ---- FF FF FF FF [H: -98 dBm] [V: -98 dBm] [E: -99 dBm]
3 2425 Hz ---- FF FF FF FF [H: -99 dBm] [V: -99 dBm] [E: -99 dBm]
4 2435 Hz ---- FF FF FF FF [H: -99 dBm] [V: -98 dBm] [E: -99 dBm]
5 2445 Hz ---- FF FF FF FF [H: -99 dBm] [V: -98 dBm] [E: -98 dBm]
6 2455 Hz ---- FF FF FF FF [H: -99 dBm] [V: -99 dBm] [E: -99 dBm]
7 2465 Hz ---- FF FF FF FF [H: -99 dBm] [V: -99 dBm] [E: -99 dBm]
8 2475 Hz ---- FF FF FF FF [H: -99 dBm] [V: -99 dBm] [E: -99 dBm]
#>
```

In this example, an AP is detected on channel 1 with polarization horizontal. Furthermore, the Base ID is 1234 and the MAC address is 00 01 DE 18 6A 05.

RSSI Command for Antenna Alignment

Step 1 Telnet into the SU (while in Opmode "OFF"). Use the *freq* and *antenna* command to note current radio settings.

Step 2 Run the *rssi* command. The telnet session screen will begin a continuous readout of the received signal strength. As you read the RSSI reading, move the antenna in the horizontal and vertical planes until the maximum RSSI reading is achieved. To allow for plenty of fade margin we recommend a continuous RSSI reading of -78 dBm or better. An RSSI of -88 dBm will allow you to establish a wireless link, but there may not be sufficient fade margin for reliable and continuous operation.

Example 1 has the wrong freq and antenna settings:

```
#> rssi
[ 1] peak -99 dBm avg -99 dBm
[ 2] peak -99 dBm avg -99 dBm
[ 3] peak -99 dBm avg -99 dBm
```

Example 2 has the correct freq and antenna settings:

```
#> rssi
[ 1] peak -38 dBm avg -80 dBm *
[ 2] peak -38 dBm avg -75 dBm **
[ 3] peak -37 dBm avg -75 dBm **
```

Step 3 If it is not possible to receive an adequate RSSI reading it may be necessary to reorient the AP (up/down, left/right) to increase the output power. Or move the SU to a location with better line-of-sight to the AP. Alternatively consider using external antennas on either the AP or SU or both.

Once you are satisfied with the RSSI reading, tighten down the SU in the optimum position. To stop the RSSI continuous readout hit SPACE ENTER.

SU Alignment Using LEDs

The LED RSSI indicators on the bottom of the radio provide a handy alignment tool. If all four LEDs are lit, the unit is receiving -64 dBm or stronger. If no LEDs are lit, there is not sufficient signal strength to establish a wireless link.

Lit LEDs	Signal Strength
0 LED	-86 dBm or weaker
1 LED	-76 to -85 dBm
2 LED	-69 to -75 dBm
3 LED	-66 to -70 dBm
4 LED	-65 dBm and stronger

Note: RSSI tool (telnet or LEDs) will show all RF energy on a given freq. i.e. – a nearby SU on the same freq. passing traffic may give the appearance of a strong signal from your AP when in fact it is not and cause a misalignment.

Link Management Commands

Once the radios are properly aligned for maximum RSSI, ensure the SU's default Opmode is "ON" and that all configuration parameters are correct.

Reboot the SU. Once the SU enters Opmode "ON" the authentication process will begin, and the two radios will begin to associate. From the AP side, there are several basic diagnostics commands, such as *su ping*, *su info*, and *su testrflink*, which can check if a reliable RF link has been established. It may take one minute or more for the association process to complete. This process may take longer if there are many SUs in the sector.

If all tests show favorable results, the wireless link will automatically begin passing Ethernet traffic between the radios.

In establishing and diagnosing the quality of the link between AP and SU(s), there are a few commands that are especially useful. All of these commands are performed at the AP. A summary of these commands follows:

su

Displays the status of all SUs in the AP's SUDB. SUs in the SUDB will appear by SU ID, and will be classified into one of the following status categories: Associated, Associating, or OFF. All associated SUs will be indicated.

Example:

```
#> su
[Priority] 1
[0] 1
[1]
[2]
[3]
[4]
[5]
[Associating]
[Power Off] 17
Success.
```

su ping <suID>

AP will send 10 RF pings to the designated SU ID. The response from each ping will indicate latency (in micro-seconds) and the received signal strength (RSSI) from the SU for each of the 10 pings. Note this command will also tell you the distance from the AP to the SU.

Example:

```
#> su ping 1
[#Begin]
```

```
[001]
Ping #0 -> -52 dB 220 us 0.0 mi
Ping #1 -> -53 dB 219 us 0.0 mi
Ping #2 -> -53 dB 220 us 0.0 mi
Ping #3 -> -52 dB 220 us 0.0 mi
Ping #4 -> -53 dB 219 us 0.0 mi
Ping #5 -> -52 dB 220 us 0.0 mi
Ping #6 -> -50 dB 220 us 0.0 mi
Ping #7 -> -52 dB 220 us 0.0 mi
Ping #8 -> -52 dB 220 us 0.0 mi
Ping #9 -> -52 dB 220 us 0.0 mi
[#End]
Avg = -51 dB
Success.
```

su <suid>

AP will poll the SU for SU's current status and will provide information such as SU range from AP, signal strength received at SU from AP, SU temperature, etc.

Example:

```
#> su 1
[ 1] pr [as] y [d] 0.0 [rssi at ap] -50 dBm [rssi at su] -60 dBm
[ip] 10.8.1.234 [subnet] 255.255.255.192 [gateway] 10.8.1.193
[mac] 00 01 DE 19 F0 A4
[hw ver] 0006 [fpga ver] 04042201 [fpga chksum] 47231EEE
[fw ver] 1p0x8 [fw chksum] 6DDF232C [fw datecode] 04061502
[default channel and antenna] 1 h [active channel and antenna] 1 h
[tx power] 23 dBm
[ch#1] 2405 [ch#2] 2415 [ch#3] 2425 [ch#4] 2435 [ch#5] 2445 [ch#6] 2455
[ch#7] 2465 [ch#8] 2475
[remarks]
[RF Tx Retry at AP] 0 [RF Tx Retry Maxed Out at AP] 0
[RF Tx Retry at SU] 0 [RF Tx Retry Maxed Out at SU] 0
Success.
```

```
#>
```

su linktest <suid>

This command checks the integrity of the wireless link from the standpoint of performance (throughput) and over-the-air packet loss. The AP will send 100 1600 byte packets to the SU, and the SU will return the packets it receives to the AP. A perfect link (without dropped packets) will yield average throughput of 5,000 Kbps. If heavy packet loss occurs it may be caused by interference or multi-path.

Example:

```
#> su linktest 1
[suid] 1 [pkt len] 1600 bytes [# of pkts per cycle] 100 [cycle] 10
0 [AP Tx] 100 [AP Rx] 100 [AP RxErr] 0 [SU Tx] 100 [SU Rx] 100 [SU RxErr] 0 5
00 ms 5120 kbps
1 [AP Tx] 100 [AP Rx] 100 [AP RxErr] 0 [SU Tx] 100 [SU Rx] 100 [SU RxErr] 0 5
00 ms 5120 kbps
2 [AP Tx] 100 [AP Rx] 100 [AP RxErr] 0 [SU Tx] 100 [SU Rx] 100 [SU RxErr] 0 5
00 ms 5120 kbps
3 [AP Tx] 100 [AP Rx] 100 [AP RxErr] 0 [SU Tx] 100 [SU Rx] 100 [SU RxErr] 0 5
00 ms 5120 kbps
```

Deployment

```
4 [AP Tx] 100 [AP Rx] 100 [AP RxErr] 0 [SU Tx] 100 [SU Rx] 100 [SU RxErr] 0 5
00 ms 5120 kbps
5 [AP Tx] 100 [AP Rx] 100 [AP RxErr] 0 [SU Tx] 100 [SU Rx] 100 [SU RxErr] 0 5
00 ms 5120 kbps
6 [AP Tx] 100 [AP Rx] 100 [AP RxErr] 0 [SU Tx] 100 [SU Rx] 100 [SU RxErr] 0 5
00 ms 5120 kbps
7 [AP Tx] 100 [AP Rx] 100 [AP RxErr] 0 [SU Tx] 100 [SU Rx] 100 [SU RxErr] 0 5
00 ms 5120 kbps
8 [AP Tx] 100 [AP Rx] 100 [AP RxErr] 0 [SU Tx] 100 [SU Rx] 100 [SU RxErr] 0 5
00 ms 5120 kbps
9 [AP Tx] 100 [AP Rx] 100 [AP RxErr] 0 [SU Tx] 100 [SU Rx] 100 [SU RxErr] 0 5
00 ms 5120 kbps
```

```
[AP Total nTx] 1000 pkts
[AP Total nRx] 1000 pkts
[AP Total nRxErr] 0 pkts
```

```
[SU Total nTx] 1000 pkts
[SU Total nRx] 1000 pkts
[SU Total nRxErr] 0 pkts
```

```
[AP to SU Error Rate] 0.00 %
[SU to AP Error Rate] 0.00 %
```

```
[Avg of Throughput] 5120 kbps
```

#> Success.

su testfrlink <suid>

This command also checks the integrity of the wireless link from the standpoint of over-the-air packet loss. In this test, the AP will send 20 large (1512 byte) packets to the SU, and the SU will in turn send the same 20 packets back to the AP. The expected result of an error free link is 20..20..20, indicating (in the following sequence) 20 packets sent from AP, 20 packets received back at AP, and 20 packets received at the SU. Any results other than 20..20..20 indicates a performance problem, most likely due to interference or inadequate signal to noise ratio. For thorough results it is recommended you run the command repeatedly for at least 1 minute or more to determine if packets are passing without error consistently over time. This command will give results without the help from ARQ. Note: This test does not provide as much detail as the ***linktest*** command.

The “r” is used in this command to repeat the RF link test repeatedly until the user terminates the test by hitting SPACE ENTER.

Example:

```
#> su testfrlink 1 r
```

Press [space] then [enter] to stop

```
[len] 1512
```

```
[suid] 1
```

```
[ 0] .....[AP Tx] 20 [AP Rx] 20 [SU Rx] 20
[ 1] .....[AP Tx] 20 [AP Rx] 20 [SU Rx] 20
[ 2] .....[AP Tx] 20 [AP Rx] 20 [SU Rx] 20
[ 3] .....[AP Tx] 20 [AP Rx] 20 [SU Rx] 20
[ 4] .....[AP Tx] 20 [AP Rx] 20 [SU Rx] 20
[ 5] .....[AP Tx] 20 [AP Rx] 20 [SU Rx] 20
```

Success.

```
#>
```

As another example, a result of 20..10..18 would indicate 20 packets sent from the AP, 18 packets received at the SU, and 10 packets received back to the AP. These types of results may be caused by Fresnel zone infringements, interference, or multi-path.

ARQ with Selected Repeat and Multirate Feature

The M2400S features ARQ, or “Automatic Repeat Request,” which provides the ability to correct for missing or erred packets of data by asking the sender to re-transmit the data.

Both the AP and SU units implement a form of ARQ known as Selective Repeat.

The units make a first attempt at transmitting a data frame using the 5.5 Mbps rate. Then, if a re-try is required, the 2nd attempt will be at 5.5 Mbps as well. The 3rd and 4th attempts will be at a rate of 2.75 Mbps. After the 4th attempt there will be no more re-tries. A counter describing “maximum retries reached” will be incremented.

- A minimum of 100ms is placed between re-transmission requests.
- The units buffer up to 1200 frames or 4 seconds worth of RF TX Data frames to support the ARQ algorithm.
- The AP unit maintains counters concerning the ARQ algorithm on a per SU basis. The counters shall include the following data:
 - Total Transmitted Frames
 - Total Retransmission Attempts
 - Total “Maximum Attempts Reached”

The SU also maintains a counter concerning its use of the ARQ algorithm. Counters include the following data:

- Total Transmitted Frames
- Total Retransmission Attempts
- Total “Maximum Attempts Reached”

Section 8 Management

Section Topics:

- Radio Management Access via TCP/IP
- SU Management from AP’s command set
- SNMP

Radio Management Access Via TCP/IP

The IP Address of an M2400S radio is for management purposes only. The IP address is not used for routing purposes or passing traffic. Users should take care to set appropriate IP schemes for all management activities including upgrading the radio’s firmware. It is not uncommon for users to assign public IP addresses to radios so that they can be accessed from anywhere on the Internet. In order to gain TCP/IP access to the SU (from either side of the wireless network) ensure that the SU switches 2 and 6 are turned on. In order to gain TCP/IP access to the AP from the SU side of the wireless network ensure that AP switch 7 is turned on.

SU Management from AP

The AP provides several commands that permit the management of associated SUs. In fact, most system management functions are performed by issuing commands from the AP. Presented below are a few examples of these commands:

```

su <all | suid, 1..126>
su info <suid, 1..126>
su linktest <suid, 1..126>
su password <suid | all> <rw|ro> <new password> <new password>
su ping <suid, 1..126>
su reboot <suid | all>
su sw <suid | all> <sw#, 0..7> <on | off>
su testrflink <suid, 1..126> <r>
su testrflink <all> <r>

```

Note: SU commands issued from the AP will automatically update the SU’s flash memory. No *save ss* command is necessary.

2. **Tftp** the file to the AP from your DOS prompt (example: **tftp <IP of AP> put mySUs.txt**).
3. From the AP telnet session run command **sudb dload** to load and activate the database.
4. Run command **sudb view** to verify the database entries.
5. Run the command **save sudb** to write the database to non-volatile memory.

SNMP

The M2400S supports Simple Network Management Protocol (SNMP) for network management. Network management consists of the following 4 categories: configuration, accounting, alarm, and monitoring and control. These capabilities allow the network operator to provide superior services through higher network availability and an integrated accounting system. For more information on SNMP and its uses you can visit <http://www.faqs.org/faqs/snmp-faq/>.

The Trango SNMP solution supports MIB-II (system only) and the Trango proprietary Management Information Base (MIB). The SNMP agent resides on the AP ONLY. It gathers health, status and performance statistics from all SUs locally. The agent then responds back to the SNMP manager upon request.

Users interested in using the SNMP functionality should review the entire M2400S MIB for a complete understanding of its features. The M2400S MIB is available for download at:

<http://www.trangobroadband.com/support/downloads.htm>

The following is an overview of a few of the more commonly used SNMP objects in the M2400S system.

Objects for Monitoring and Control

SU Bandwidth Monitoring

- **suRFInOctets** – Number of octets of payload transmitted from AP's RF port.
- **suRFOutOctets** – Number of octets of payload received on AP's RF port.

AP Bandwidth Monitoring

- **aptrafficEthInOctets** – Number of octets of payload received on the Ethernet port.
- **aptrafficEthOutOctets** – Number of octets of payload transmitted from the Ethernet port.
- **aptrafficRFInOctets** – Number of octets of payload received on the RF port.
- **aptrafficRFOutOctets** – Number of octets of payload transmitted from the RF port.

Link Status Monitoring – Various traps are defined as follows:

- SU Link Up – When SU associates to the AP
- SU Link Down – When SU disassociates from the AP

AP and SU Control – SNMP also provides several control capabilities. The majority of the features available on the CLI are also available in SNMP. Here are a few of these features:

- Add/delete subscriber
- Change channel
- Set power
- Set radio sensitivity

Review the Trango M2400S MIB for the complete listing of MIB Objects.

SNMP Setup

Trango Broadband provides only the MIB portion of the SNMP Management system. The radios act as individual agents, and it is up the user to provide an SNMP Manager software from a third party vendor. Below is an example of the setup process for SNMPC from Castle Rock™.

1. Unzip `trangopkg.zip` file to a local temporary directory.
2. Go to your local temporary directory. You will find 4 files as shown below.
 - a. `trango_m2400sap_1p0.mib` – M2400S AP MIB file

- b. trango.ico – M900S AP icon
- c. autoico.txt – instruction file (Selects Trango icon automatically during initial set-up.)
- d. readme.pdf
3. Copy trango_m2400sap_1p0.mib file to C:\Program Files\SNMPC Network Manager\mibfiles
4. Copy autoico.txt file to C:\Program Files\SNMPC Network Manager\mibfiles
5. Copy trango.ico file to C:\Program Files\SNMPC Network Manager\bitmaps
6. The MIB needs to be compiled into the SNMPC database

By default, the Read Community is set to “**public**,” and the Write Community is set to “**private**” in the AP. The Trap Community is “**SNMP_trap**.” The manager needs to have the same settings in order to communicate with the AP successfully.

To send traps from the AP set the following:

- trap destination IP (Trango MIB object trapconfig–trapconfigInfo)
- trap community string (Trango MIB object trapconfig–aptrpTable-AptrpEntry)
- enable each trap (Trango MIB object traonfig–aptrpTable-AptrpEntry)

Appendix A Command Set Reference

(ro = read only access, rw = read write access)

Command	Radio	Description	Access
?	AP/SU	Display complete list of commands and syntax	ro/rw
? <command>	AP/SU	Display specific command syntax	ro/rw
antenna	AP/SU	Display current antenna setting (h=horizontal, v=vertical, e=external)	ro/rw
antenna <e h v>	AP/SU	Select antenna mode (h=horizontal, v=vertical, e=external)	rw
aprssi <ch#> <antenna, h v e>	AP/SU	Scan two strongest APs (Opmode "OFF" only)	ro/rw
apsearch	AP/SU	Scan all channels to look for APs (Opmode "OFF" only)	ro/rw
arq	AP/SU	Display current ARQ settings	ro/rw
arq <on/off>	AP/SU	Enable/disable ARQ	rw
bye	AP/SU	Same as "logout"	ro/rw
eth link	AP/SU	Display current Ethernet setting	ro/rw
eth link <100fdx 100hdx 10fdx 10hdx aneg>	AP/SU	Change Ethernet duplex setting	rw
exit	AP/SU	Same as "logout"	ro/rw
freq	AP/SU	Display current channel	ro/rw
freq <ch#>	AP/SU	Change current channel	rw
freq channeltable	AP/SU	Display channel table	ro/rw
freq writechannel [<ch #> <freq>]...	AP/SU	Modify center frequency of channel. <ch #> = 1..8 <freq> = 2405..2475 Note: This command automatically writes to flash memory.	rw
help	AP/SU	Display complete list of commands and syntax	ro/rw
help <command>	AP/SU	Display specific command syntax	ro/rw
ipconfig [<new ip> <new subnet mask> <new gateway>]	AP/SU	Assign radio's IP, subnet mask, and gateway IP	rw
linktest <txrx rxtx> [<pkt len, bytes> [<# of pkts> [<# of cycle>]]]	AP/SU	Loopback test to check quality of the wireless link. Variable parameters include: pktlen = 64..1760, # 0 pkts = 1..500 # of cycles = 1..100000	ro/rw
logout	AP/SU	Log out of radio	ro/rw
maclist	AP/SU	Display current MAC table (MAC addresses of attached devices)	ro/rw
maclist reset	AP/SU	Display or reset current MAC table	ro/rw
mirth	AP	Display MIR (Maximum Information Rate) Threshold	ro/rw
mirth <0..3, Mbps>	AP	Assign MIR Threshold default = 3 Mbps mirth 0 = Always On mirth 3 = Disable MIR Threshold	rw
opmode	AP/SU	Display current Opmode	ro/rw
opmode on [<y>]	AP/SU	Set Opmode to be "ON" and use "y" if Opmode is not as same as default Opmode	ro/rw
password <rw/ro> <new pwd> <new pwd>	AP/SU	Specify new password (max 15 octs) rw=read/write password, ro=read only password	rw
ping <ip address>	AP/SU	Ping local Ethernet device Note: This command only works for local Ethernet devices, not SU or any device behind SU.	ro/rw
power	AP/SU	Display current TX power level default = max. power value	ro/rw
power set <min max <dBm>	AP/SU	Specify TX power for both band Note: SU's power will be adjusted by AP during association process (power leveling)	rw

Command	Radio	Description	Access
pppoeonly	SU	Display current PPPoE filter setting	ro/rw
pppoeonly <on off>	SU	Change PPPoE filter setting With PPPoE filter set to ON, only PPPoE packets will pass Default: off – Pass All Packets	rw
reboot	AP/SU	Reboot unit	ro/rw
remarks	AP/SU	Display remarks	ro/rw
remarks <str,31 octs>	AP/SU	Overwrite remarks	rw
reset	AP/SU	Reset radio's system settings back to factory defaults, then reboot	rw
rfrxth	AP/SU	Display current RF RX Threshold	ro/rw
rfrxth <-98..-55>	AP/SU	Change current RF RX Threshold default = -98 dBm	rw
rssi	AP/SU	Display current RX RSSI for packets received during a 1s window Opmode "OFF" only on AP	ro/rw
save <mainimage fpgaimage> <current chscksum> <new checksum>	AP/SU	Save new firmware. This command gets new firmware image from TFTP buffer, verifies checksum and writes to flash memory at main or FPGA image section.	rw
save subd	AP	Save SUBD into flash memory	rw
save <systemsetting ss>	AP/SU	Save current configuration into flash memory	rw
set apid <ap-id>	AP	Set AP ID, <ap-id> = 1..255	rw
set baseid <base-id, 4 oct>	AP/SU	Set base station id Base ID = XXXX where X = any alphanumeric character except "/"	rw
set defaultopmode <on off>	AP/SU	Set default Opmode to "ON" or "OFF" Factory set default Opmode is "OFF"	rw
set httpport [<port #>]	AP/SU	Set or display HTTPD port number port # = 1..65534 default port = 80	rw
set snmpcomm <read write trap id# trap all>	AP/SU	Set SNMP read or write or trap community string	rw
set telnetport [<port #>]	AP/SU	Specify telnet port, <port #> = 1..65534 Default port = 23	rw
snmpsample <min, 1..60>	AP/SU	Set SNMP sample period	rw
su password <suid all> <rw ro> <new password> <new password>	AP	Change read/write or read-only password of all or a specific subscriber	rw
su <all suid>	AP	Display all or specific SU information in SUBD	ro/rw
su info <suid>	AP	Command issued from the AP to gather information about specific SUs. <ol style="list-style-type: none"> 1. Distance 2. RSSI at AP 3. RSSI at SU 4. IP address 5. Subnet address 6. Gateway address 7. Device ID 8. Hardware version 9. FPGA version 10. FPGA checksum 11. Firmware version 12. Firmware checksum 13. Firmware datecode 14. Broadcast/multicast packet filter on/off 15. Auto scan AP on/off 16. TCP/IP for AP on/off 17. HTTPD on/off 18. TCP/IP service for Ethernet port on/off 19. Default channel and antenna 20. Active channel and antenna 21. TX power 	ro/rw

Command	Radio	Description	Access
		22. Remarks 23. RF TX retry at AP, RF TX retry maxed out at AP RF TX retry at SU, RF TX retry maxed out at SU	
su ipconfig <suid> <new IP> <new subnet> <new gateway>	AP	Change IP, subnet, gateway for specified SU	rw
su linktest <suid>	AP	Perform linktest for specified SU	ro/rw
su ping <suid>	AP	Request SU's ranging and RSSI information	ro/rw
su reboot <all suid>	AP	Reboot a specific SU or all SUs	rw
su sw <suid> <sw #> <on off>	AP	Change switch settings on specified SU	rw
sudb add <suid> <pr><re> <mac>	AP	Add new SU to SUDB	rw
sudb cirmir <<suid> all> <cir dn> <cir up> <mir dn> <mir up>	AP	Change SU's CIR/MIR settings	rw
sudb defaultcirmir	AP	Display default CIR and MIR in SUDB	ro/rw
sudb defaultcirmir <cir_dn, 0..3000> <cir_up, 0..3000> <mir_dn, 0..3000> <mir_up, 0..3000>	AP	Change default CIR and MIR	rw
sudb defaultcirmir <default cir dn> <default cir up> <default mir dn> <default mir up>	AP	Set MIR/CIR values to default values	rw
sudb delete <suid all>	AP	Delete SU in SUDB	rw
sudb dload	AP	Download SUDB file from TFTP buffer and write to flash memory. This command is used to load a text file that contains the SUDB into the AP. This command can be useful if there are large numbers of SUs in the sector.	rw
sudb gid <suid all> <0..15>	AP	Change SU's gid	rw
sudb view	AP	Display all SUDB	ro/rw
survey <search time, sec> <antenna, h v e>	AP/SU	Spectrum analysis of the entire band (and near band) <search time> = 1..10 sec per channel Opmode "OFF" only	ro/rw
Sw	AP/SU	Display current sw setting	ro/rw
sw 0 [<on off>]	AP/SU	set sw #0 – enable or disable packet filter for broadcast/ multicast packets on = filtering default = on	rw
sw 1 [<on off>]	SU	Enable or disable SU's autoscan AP feature If on, SU will automatically scan each channel and antenna port searching for AP. default=on	rw
sw 2 [<on off>]	SU	Enable or disable SU's TCP/IP service for AP Allows TCP/IP access to SU from AP side of network via wireless link. default = on	rw
sw 3 [<on off>]	AP	Enable or disable SU to SU (peer to peer) service default = off	rw
sw 5 [<on off>]	AP/SU	Enable or disable HTTPD (browser interface) default = on	rw
sw 6 [<on off>]	SU	Enable or disable TCP/IP service for Ethernet port while SU is in Opmode "ON" default = on	rw
sw 7 [<on off>]	AP	Enable or disable TCP/IP service for SU. Allows TCP/IP access to AP from SU side of network via wireless link. default = on	rw
sysinfo	AP/SU	Display system configuration	ro/rw
targetap	SU	Display the SU current setting for target AP	ro/rw
targetap all	SU	SU will associate with any AP with the same Base ID "all" is the default setting.	rw
targetap only <mac1, hex> [<mac2, hex>]	SU	SU will only associate with AP with specified MAC addresses.	rw
targetrssi	AP	Display SU Target RSSI in dBm. This setting is used in the SU power leveling process.	ro/rw
targetrssi <dBm, -90..-50>	AP	Change target RSSI. Note: Target RSSI must be +5 dB more than rfrxth (RFRX Threshold).	rw

Command	Radio	Description	Access
		default = -60	
tftpd	AP/SU	display current TFTP status (status is either on or off) This command will also list any contents of the TFTP buffer.	ro/rw
tftpd <on off>	AP/SU	enable or disable TFTP service. TFTP must be on in order to upload new firmware or new SUDB file.	rw
updateflash <systemsetting ss>	AP/SU	Save current settings. This command can be issued in several ways: save ss, updateflash systemsetting, save systemsetting, and updateflash ss	rw
updateflash <mainimage fpgaimage> <current chcksum> <new checksum>	AP/SU	Retrieve uploaded firmware from TFTP buffer, verify checksum, and write to flash memory at main or FPGA image section.	rw
updateflash sudb	AP	Save SUDB into flash memory	rw
ver	AP/SU	Display firmware and date codes 1. Version number and date code 2. Firmware and FPGA version code 3. Firmware and FPGA image checksum	ro/rw

Appendix B Specifications

All specifications apply to M2400S-AP and M2400S-SU unless otherwise noted.

Radio Transmit Specifications

Storable Channels:	8 memory locations
Agility:	2405 to 2475 MHz in 1 MHz increments
Default channels-	
Channel 1:	2405 MHz
Channel 2:	2415 MHz
Channel 3:	2425 MHz
Channel 4:	2435 MHz
Channel 5:	2445 MHz
Channel 6:	2455 MHz
Channel 7:	2465 MHz
Channel 8:	2475 MHz
Power Control Range:	Max: +23 dBm +/- 1 Min: +10 dBm +/- 2 Step: 1 dB
Pout:	+23 dBm max
Ant. Gain:	13 dBi (AP), +15dbi (SU)
EIRP:	+36 dBm (4 Watt) (AP), 38.5 dbm (SU w/ internal antenna)
Freq. Stability:	+/- 2.5 ppm PLL stabilized over temperature
Freq. Plan:	Upconversion from BB to 426 MHz IF to 2400 MHz
Modulated BW:	10 MHz (null to null, 40 dB down)
2 nd Harmonic atten:	Per CFR47 part 15.247
LO Supression:	Per CFR47 part 15.247

Receiver Specifications

Storable Channels:	8 memory locations
Agility:	2405 to 2475 MHz in 1 MHz increments
Default channels-	
Channel 1:	2405 MHz
Channel 2:	2415 MHz
Channel 3:	2425 MHz
Channel 4:	2435 MHz
Channel 5:	2445 MHz
Channel 6:	2455 MHz
Channel 7:	2465 MHz
Channel 8:	2475 MHz
Cascade Noise Figure:	< 5 dB
Receiver Sensitivity:	
5.5 MBPS Rate: (1x10 ⁻⁶ BER)	- 88 dBm typical-1600 byte packet - 88 dBm typical-64 byte packet
2.25 MBPS Rate: (1x10 ⁻⁶ BER)	- 91 dBm typical-1600 byte packet - 91 dBm typical-64 byte packet
Image Rejection:	> 90 dB
Frequency Plan:	Down conversion from 2400 MHz to 426 MHz IF to BB

LO stability: +/- 2.5 ppm PLL stabilized over temperature

Ethernet I/O Specifications

Data Input/Output:

Connector: Shielded RJ-45 Jack
Signaling Format: IEEE802.3i (10baseT) and IEEE802.3u (100baseT) compliant
Filtering: PPPoE per RFC 2516 (SU only)
Auto-Negotiation: Fully supports IEEE802.3-2002 Sect. 2 Clause 28
Bridging Frame Size: 60 to 1600 bytes
Mngmt Frames: 60 to 1472 bytes. (includes PING, TELNET, TFTP, HTTP)

Protection: Bi-directional transient voltage protection diodes on all data lines compliance with:
IEC61000-4-2 (ESD)
IEC61000-4-4 (EFT)
IEC61000-4-5 (Lightning)

Power Specifications

Input Voltage: Input voltage range at unit is 10.5 VDC to 24 VDC max

Power is supplied via unused pins of the RJ-45 Jack. Power is injected into Ethernet cable using a junction box (J-Box) provided.

Current Cons.: 500 mA in transmit and receive modes at max power using 20 V standard adapter (10 W) and 10 ft cable from J-Box to unit

Protection: 28 volt Transient Voltage Suppression (TVS) diode on power input
Note: Voltages above 28 volts will cause damage to unit.

Mechanical and Environmental Specifications

General

Material: High temp polycarbonate radome and diecast metal enclosure
Size: 12.5" x 8" x 2.75" including mounting studs
Weight: 4 lb
Mounting: 2 U-Brackets, all-thread rod, nuts and washers

Connectors/Indicators

RF Output: Integral internal patch antenna per Part 15C, 15.203
External RP-SMA-f connector for external antenna

FCC Compliance: The transceiver complies with the following:
FCC Part 15.247
FCC Part 15.207(a)

Environmental

Operating Temp: -40 to 60 deg C
Storage: -40 to 85 deg C
Humidity: 100 % when sealed properly
NEMA Rating: NEMA 4
Shock: Sustain 3 axis drop from 5 feet

Standard External Power Supply

20 Volt DC Power adapter and J-Box supplied with product.

Type: Linear wall mount transformer
Input: 120 VAC
Output: 20 VDC +/- 1 V
Max current: 600 mA
Connector: 5mm DC barrel-type plug

Standard External Power-over-Ethernet Junction Box

Type: In-line female-to-female RJ-45 adapter for CAT-5 Ethernet cable

Connectors:

Eth. In: Shielded RJ-45 Jack
DC Input: 5mm DC Barrel-type Jack
Eth. Out & DC Out: Shielded RJ-45 Jack

Pinout for Eth. Out: Power (+) on pins 7+8, ground (-) on pins 4+5, and eth. data on pins 1,2,3 & 6

Indicators: 2 LEDs to indicate power and a connection to radio
Protection: Resettable fuse for DC input

Integrated Antenna AP

Type: Air-loaded Patch Antenna
Polarization: Vertical or Horizontal Polarization (electrically selectable)
Frequency: 2405 to 2475 MHz
Gain: +13 +/- 1 dBiL
Az Beamwidth: 60 degrees (3 dB pts)
El Beamwidth: 18 degrees (3 dB pts)
Cross Pol: >15 dB
Front/Back Ratio: 12 dB
VSWR: < 2.0:1 over bandwidth

Integrated Antenna SU

Type: Air-loaded Patch Antenna
Polarization: Vertical or Horizontal Polarization (electrically selectable)
Frequency: 2405 to 2475 MHz
Gain: +15 +/- 1 dBiL
Az Beamwidth: 32 degrees (3 dB pts)
El Beamwidth: 18 degrees (3 dB pts)
Cross Pol: >15 dB
Front/Back Ratio: 12 dB
VSWR: < 2.0:1 over bandwidth