

SpeedStream®

Powerline Wireless Router

Model SS2524

SIEMENS

Part No. 007-0382-001

TABLE OF CONTENTS

CHAPTER 1 INTRODUCTION	1
Features.....	1
Package Contents.....	3
Physical Details.....	4
CHAPTER 2 INSTALLATION.....	6
Requirements.....	6
Procedure.....	6
CHAPTER 3 SETUP.....	8
Overview	8
Configuration Program	10
Setup Wizard.....	12
LAN Screen.....	16
Wireless Configuration.....	18
Powerline Configuration.....	23
Password Screen	24
CHAPTER 4 PC CONFIGURATION.....	26
Overview	26
Windows Clients	26
Macintosh Clients	38
Linux Clients.....	38
Other Unix Systems	38
Wireless Station Configuration	40
Powerline Configuration.....	41
CHAPTER 5 OPERATION AND STATUS.....	42
Operation	42
Status Screen.....	43
Connection Status - PPPoE.....	45
Connection Status - PPTP.....	47
Connection Details - Fixed/Dynamic IP Address	48
CHAPTER 6 ADVANCED FEATURES	50
Overview	50
Advanced Internet Screen	50
URL Filter.....	54
Virtual Servers.....	56
Dynamic DNS.....	59
Remote Management.....	62
Access Control	63
Firmware Upgrade	68
CHAPTER 7 ADVANCED CONFIGURATION	69
Overview	69
Network Clients Screen.....	70
Options.....	72
MAC Address	74
Routing.....	76

Security	80
APPENDIX A TROUBLESHOOTING.....	82
Overview	82
General Problems	82
Internet Access.....	82
APPENDIX B SPECIFICATIONS	84
SpeedStream Powerline Wireless Router.....	84
APPENDIX C TECHNICAL SUPPORT	86

© 2002 Efficient Networks, Inc. A Siemens Company. All rights reserved. Efficient Networks, its logos and SpeedStream are registered and unregistered trademarks of Efficient Networks, Inc. Siemens and the Siemens logo are trademarks of Siemens AG, Germany. All other trademarks are held by their respective companies. Efficient Networks reserves the right to make changes to product specifications at any time without notice.

All trademarks and trade names are the properties of their respective owners.

Chapter 1

Introduction

1

This Chapter provides an overview of the SpeedStream Powerline Wireless Router's features and capabilities.

Congratulations on the purchase of your new SpeedStream Powerline Wireless Router; commonly referred to as a Broadband Router. The SpeedStream Powerline Wireless Router is a multi-function device providing the following services:

- **Wireless LAN Access Point** for equipment compliant with the IEEE802.11b (DSSS) specifications.
- **Shared Broadband Internet Access** for all LAN users.
- **4-Port Switching Hub** for 10BaseT or 100BaseT connections.
- **Powerline Adapter** to link your Powerline users to the LAN and Wireless LAN.

10/100Base-T LAN

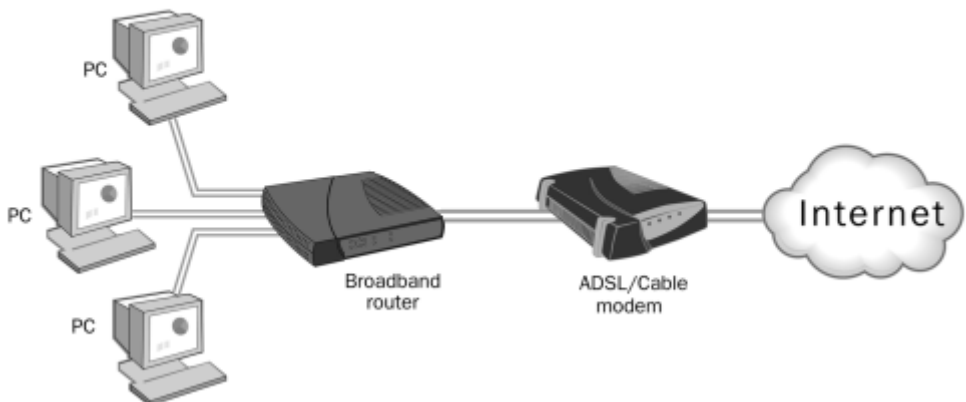

Figure 1: SpeedStream Powerline Wireless Router

Features

The SpeedStream Powerline Wireless Router incorporates many advanced features, carefully designed to provide sophisticated functions while being easy to use.

Internet Access Features

- **Shared Internet Access.** All users on the LAN can access the Internet through the SpeedStream Powerline Wireless Router, using only a single external IP Address. The local (invalid) IP Addresses are hidden from external sources. This process is called NAT (Network Address Translation).
- **DSL & Cable Modem Support.** The SpeedStream Powerline Wireless Router has a 10/100BaseT Ethernet port for connecting a DSL or Cable Modem. All popular DSL and Cable Modems are supported.

- **PPPoE and PPTP Support.** The Internet (WAN port) connection supports PPPoE (PPP over Ethernet) and PPTP (Peer-to-Peer Tunneling Protocol), as well as "Direct Connection" type services.
- **Fixed or Dynamic IP Address.** On the Internet (WAN port) connection, the SpeedStream Powerline Wireless Router supports both Dynamic IP Address (IP Address is allocated on connection) and Fixed IP Address.

Wireless Features

- **Standards Compliant.** The SpeedStream Powerline Wireless Router complies with the IEEE802.11b (DSSS) specifications for Wireless LANs.
- **WEP support.** Support for WEP (Wired Equivalent Privacy) is included. Both 64 Bit and 128 Bit keys are supported.
- **Access Control.** The Access Control feature can ensure that only trusted Wireless Stations can access your LAN.
- **Simple Configuration.** If the default settings are unsuitable, they can be changed quickly and easily.

Advanced Internet Functions

- **Conferencing & Telephony Applications.** Internet Telephony and Conferencing applications, which are often difficult to use when behind a Firewall, are supported.
- **Special Internet Applications.** Applications that use non-standard connections or port numbers are normally blocked by the Firewall. The ability to define and allow such applications is provided, to enable such applications to be used normally.
- **Virtual Servers.** This feature allows Internet users to access Internet servers on your LAN. The required setup is quick and easy.
- **DMZ.** One (1) PC on your local LAN can be configured to allow unrestricted 2-way communication with Servers or individual users on the Internet. This provides the ability to run programs that are incompatible with Firewalls.
- **URL Filter.** Use the URL Filter to block access to undesirable Web sites by LAN users.
- **Internet Access Log.** See which Internet connections have been made.
- **VPN Support.** VPN (Virtual Private Networking) connections using PPTP and IPSec are transparently supported - no configuration is required.

LAN Features

- **4-Port Switching Hub.** The SpeedStream Powerline Wireless Router incorporates a 4-port 10/100BaseT-switching hub, making it easy to create or extend your LAN. Any hub port will automatically act as a "unlink" port when required, making it easy to connect to another hub.
- **Powerline Interface.** The SpeedStream Powerline Wireless Router includes a standards-compliant Powerline adapter. This allows all your network users - wired, Wireless, or Powerline - to communicate with each other.
- **DHCP Server Support.** Dynamic Host Configuration Protocol provides a dynamic IP address to PCs and other devices upon request. The SpeedStream Powerline Wireless Router can act as a **DHCP Server** for devices on your local LAN and WLAN.
- **Multi Segment LAN Support.** LANs containing one or more segments are supported, via the Router's RIP (Routing Information Protocol) support and built-in static routing table.

Configuration & Management

- **Easy Setup.** Use your Web browser from anywhere on the LAN for configuration.
- **Remote Management.** The SpeedStream Powerline Wireless Router can be managed from any PC on your LAN. And, if the Internet connection exists, it can also (optionally) be configured via the Internet.
- **UPnP Support.** UPnP (Universal Plug and Play) allows automatic discovery and configuration of the SpeedStream Powerline Wireless Router. UPnP is supported by Windows ME, XP, or later.

Security Features

- **Password - protected Configuration.** Optional password protection is provided to prevent unauthorized users from modifying the configuration data and settings.
- **NAT Protection.** An intrinsic side effect of NAT (Network Address Translation) technology is that by allowing all LAN users to share a single IP address, the location and even the existence of each PC is hidden. From the external viewpoint, there is no network, only a single device - the SpeedStream Powerline Wireless Router.
- **Stateful Inspection Firewall.** All incoming data packets are monitored and all incoming server requests are filtered, thus protecting your network from malicious attacks from external sources.
- **Protection against DoS attacks.** DoS (Denial of Service) attacks can flood your Internet connection with invalid packets and connection requests; using so much bandwidth and so many resources that Internet access becomes unavailable. The SpeedStream Powerline Wireless Router incorporates protection against DoS attacks.

Package Contents

The following items should be included:

- SpeedStream Powerline Wireless Router (SS2524)
- Power Cord
- Wireless Antenna
- Quick Start Guide (QSG)
- Documentation CD-ROM
- Extended Warranty/Registration Card
- Safety and Certifications/Software License & Warranty

If any of the above items are damaged or missing, please contact SpeedStream Technical Support for assistance.

Physical Details

Front Panel LEDs

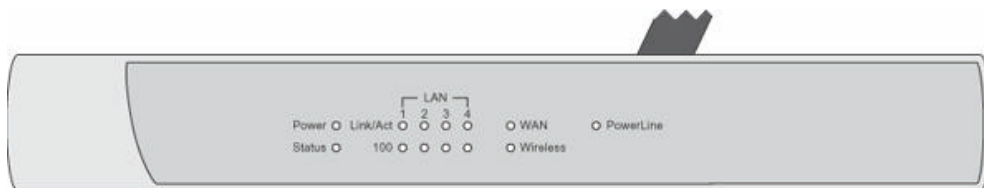

Figure 2: Front Panel

Power	<p>On - Normal operation.</p> <p>Off - No power</p>
Status	<p>On - Error condition.</p> <p>Off - Normal operation.</p> <p>Blinking - This LED blinks during start up, or when the Firmware is being upgraded.</p>
LAN	For each LAN port, there are 2 LEDs
(1, 2, 3, 4)	<ul style="list-style-type: none"> • Link/Act <ul style="list-style-type: none"> • On - Corresponding LAN (hub) port is active. • Off - No active connection on the corresponding LAN (hub) port. • Flashing - Data is being transmitted or received via the corresponding LAN (hub) port. • 100 <ul style="list-style-type: none"> • On - Corresponding LAN (hub) port is using 100BaseT. • Off - Corresponding LAN (hub) port connection is using 10BaseT, or no active connection.
WAN	<p>Flashing - data is being transmitted or received via the WAN port.</p> <p>Off - no data is being transferred.</p>
Wireless	<p>On - Wireless connection available; Wireless Access Point is ready for use.</p> <p>Off - No Wireless connection available.</p> <p>Flashing - Data is being transmitted or received via the Wireless access point. Data includes "network traffic" as well as user data.</p>
Powerline	<p>On - Powerline connection is available.</p> <p>Off - No Powerline connection available.</p> <p>Flashing - Data is being transmitted or received via the Powerline interface. Data includes "network traffic" as well as user data.</p>

Rear Panel



Figure 3 Rear Panel

- Power port** Connect the supplied power cord here.
- Aerial Antenna** Best results are usually obtained with the antenna in a vertical position.
- Reset Button** This button has two (2) functions:
- **Reboot.** When pressed and released, the SpeedStream Powerline Wireless Router will reboot (restart).
 - **Reset to Factory Defaults.** This button can also be used to clear ALL data and restore ALL settings to the factory default values.

To Clear All Data and restore the factory default values:

1. Power Off the router
2. Hold the Reset Button down while you Power On the router.
3. Continue holding the Reset Button until the Status (Red) LED blinks TWICE.
4. Release the Reset Button.
The factory default configuration has now been restored, and the Router is ready for use.

WAN port (10/100BaseT) Connect the DSL or Cable Modem here. If your modem came with a cable, use the supplied cable. Otherwise, use a standard CAT5 UTP LAN cable.

10/100BaseT LAN connectors Use standard LAN cables (RJ45 connectors) to connect to your PCs. Both 10BaseT and 100BaseT connections can be used simultaneously.

All 4 LAN ports are capable of being connected to another hub with a straight-through cable. Any port will automatically act as an “uplink” port when required.

Warning!

The case contains no user-serviceable components. Only qualified service staff should open the case.

Chapter 2

Installation

2

This Chapter covers the physical installation of the SpeedStream Powerline Wireless Router.

Requirements

Requirements:

- DSL or Cable Modem
- PC(s) with the TCP/IP protocol installed
- Cat 5 Ethernet cables with RJ-45 connectors
- Installed Powerline network adapter for each PC that will be connected to the network via Powerline.
- Installed Wireless network adapter for each PC that will be wirelessly connected to the network
- Installed 10/100 Ethernet network adapter for each PC that will be connected to the network via cabling

Procedure

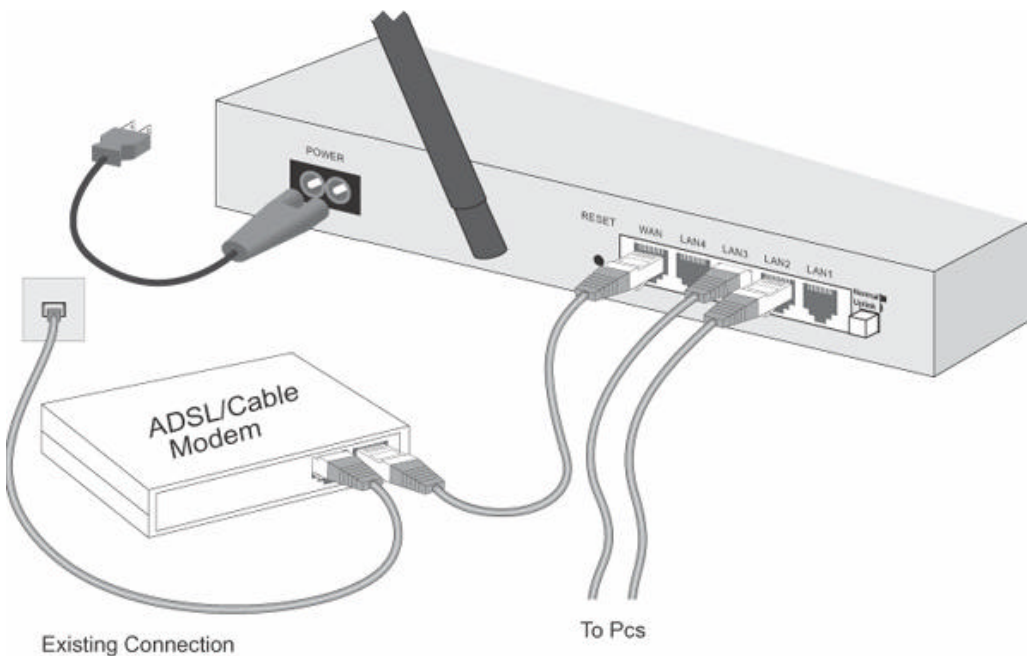

Figure 4: Installation Diagram

1. Ensure that the SpeedStream Powerline Wireless Router is powered OFF before commencing with installation. Leave your DSL/Cable modem connected to its wall socket (phone line or cable outlet).

2. Use Cat 5 Ethernet cable(s) to connect PC(s) to the hub ports on the SpeedStream Powerline Wireless Router. If desired, any port can also be connected to a standard port on another hub.
3. Connect your DSL/Cable modem to the WAN port on the SpeedStream Powerline Wireless Router using the Ethernet cable supplied with your DSL/Cable modem. If no cable was supplied with your modem, use a straight-through CAT 5 Ethernet cable.
4. Attach the wireless antenna to the connector provided on the back of the router. Secure the antenna by turning the grooved or ridged ring on the antenna until snug (Do not over tighten).
5. Connect the supplied power cord to the SpeedStream Powerline Wireless Router.



The SpeedStream Powerline Wireless Router has built-in surge protection. It is not recommended to plug the router into a power strip, surge protector or UPS as the Powerline connection speed and quality will be affected.

6. Check the LEDs:
 - The Status LED should flash, then turn Off.
 - The Power, WAN, Powerline and Wireless LEDs should be ON.
 - For each active LAN (PC) connection, the LAN Link/Act LED should be ON.

For more information, refer to Front Panel LEDs in Chapter 1.

Chapter 3

Setup

3

This Chapter provides details of the Setup process.

Overview

This chapter describes the setup procedure for:

- Internet Access
- LAN configuration
- Wireless LAN configuration.
- Powerline configuration.
- Assigning a Password to protect the configuration data.

PCs on your local LAN may also require configuration. For details, see *Chapter 4 - PC Configuration*.

Other configuration may be required, depending on which features and functions of the SpeedStream Powerline Wireless Router you wish to use. Use the table below to locate detailed instructions for the required functions.

To Do this:	Refer to:
Configure PCs on your LAN.	Chapter 4: PC Configuration
Check SpeedStream Powerline Wireless Router's operation and Status.	Chapter 5: Operation and Status
Use any of the following Internet features: <ul style="list-style-type: none">• Special Applications• DMZ• Virtual Servers• Dynamic DNS• Remote Management	Chapter 6: Advanced Features
Use any of the following Advanced Configuration settings: <ul style="list-style-type: none">• Network Clients• Options (Backup DNS, TFTP, UPnP)• Security and Firewall settings• Printer Port setup (for Linux/Unix only)• Routing (RIP and static Routing)• Firmware Upgrade	Chapter 7 Advanced Configuration



Note!

Where use of a certain feature requires that PCs or other LAN devices be configured, this is also explained in the relevant chapter.

Configuration Program

The SpeedStream Powerline Wireless Router contains an HTTP server. This enables you to connect to it, and configure it, using your Web Browser. **Your Browser must support JavaScript.** The configuration program has been tested on the following browsers:

- Netscape V4.08 or later
- Internet Explorer V4 or later

Preparation

Before attempting to configure the SpeedStream Powerline Wireless Router, please ensure that:

- The SpeedStream Powerline Wireless Router must be installed and powered ON.
- If the SpeedStream Powerline Wireless Router's default IP Address (192.168.254.254) is already used by another device, the other device must be turned OFF until the SpeedStream Powerline Wireless Router is allocated a new IP Address during configuration.
- If your PC uses a wired Ethernet connection, your PC and the SpeedStream Powerline Wireless Router must be directly connected (using the Hub ports on the Router) or on the same LAN segment.
- If your PC uses the Wireless or Powerline interfaces, the PC's settings must match those of the SpeedStream Powerline Wireless Router. The default settings are listed below.

Wireless	SSID: SpeedStream
	WEP: Disabled
	Channel: 11
Powerline	Network Password: SpeedStream

Connecting to the SpeedStream Powerline Wireless Router

Using UPnP

If your Windows operating system supports UPnP, an icon for the SpeedStream Powerline Wireless Router will appear in the system tray, notifying you that a new network device has been found, and offering to create a new desktop shortcut to the newly discovered device.

- Unless you intend to change the IP Address of the Router, you can accept the desktop shortcut.
- Whether you accept the desktop shortcut or not, you can always find UPnP devices in *My Network Places* (previously called *Network Neighborhood*).
- Double - click the icon for the SpeedStream Powerline Wireless Router (either on the Desktop, or in *My Network Places*) to start the configuration. Refer to the following section *Setup Wizard* for details of the initial configuration process.

Using your Web Browser

To establish a connection from your PC to the SpeedStream Powerline Wireless Router:

1. After installing the SpeedStream Powerline Wireless Router in your LAN, start your PC. If your PC is already running, restart it.
2. Start your Web browser.

3. In the *Address* box, enter "HTTP://" and the IP Address of the SpeedStream Powerline Wireless Router, as in this example, which uses the SpeedStream Powerline Wireless Router's default IP Address:

```
HTTP://192.168.254.254
```

If you can't connect

If the Router does not respond, check the following:

- The SpeedStream Powerline Wireless Router is properly installed, LAN connection is OK, and it is powered ON. You can test the connection by using the "Ping" command:
 - Open the MS-DOS window or command prompt window.
 - Enter the command:

```
ping 192.168.254.254
```

If no response is received, either the connection is not working, or your PC's IP address is not compatible with the SpeedStream Powerline Wireless Router's IP Address. (See next item.)
- If your PC is using a fixed IP Address, its IP Address must be within the range 192.168.254.1 to 192.168.254.253 to be compatible with the SpeedStream Powerline Wireless Router's default IP Address of 192.168.254.254. Also, the *Network Mask* must be set to 255.255.255.0. See *Chapter 4 - PC Configuration* for details on checking your PC's TCP/IP settings.
- Ensure that your PC and the SpeedStream Powerline Wireless Router are on the same network segment. (If you don't have a router, this must be the case.)
- If using a Wireless or Powerline connection, ensure that your PC's settings match the SpeedStream Powerline Wireless Router settings, as described in *Preparation* above.

Setup Wizard

The first time you connect to the SpeedStream Powerline Wireless Router, the Setup Wizard will run automatically. (The Setup Wizard will also run if the Router's default settings are restored.)

- Step through the Wizard until finished.
 - You need to know the type of Internet connection service used by your ISP. Check the data supplied by your ISP.
 - The common connection types and associated data are explained in the tables below.
- On the final screen of the Wizard, run the test and check that an Internet connection can be established.
 - If the connection fails, check your data, the Cable or DSL modem, and all connections.
 - When you exit the Wizard, you will see the Home screen. If you wish to run the Wizard again at any time, use the "Setup Wizard" button on the main menu.

Cable Modems

Data	Details	Check
Hostname	Some ISPs allocate a "Hostname". If so, you must enter this "Hostname" instead of using the default value.	Did your ISP allocate a "Hostname" to you? If so, enter the name provided. Otherwise, use the default value.
Domain name	Some ISPs allocate a "Domain Name". If so, you must enter this "Domain Name" instead of using the default value.	Did your ISP allocate a "Domain Name" to you? If so, enter the name provided. Otherwise, use the default value.
MAC address	Some ISPs record the MAC (physical) address of your PC, and will only permit connections from that address.	Does your ISP expect a particular MAC address? If YES, enter the value (if known), or use the "Clone MAC address" button to copy your PC's address to the SpeedStream Powerline Wireless Router. If NO, use the default MAC address.
IP Address	There are 2 systems used: <ul style="list-style-type: none"> Dynamic - Your IP Address is allocated automatically, when you connect to you ISP. Static - Your ISP allocates a permanent IP Address to you. 	Were you allocated a specified IP Address? If YES, select "Fixed IP address" in the Wizard, and enter the details provided by your ISP. If NO, select "Dynamic IP address" in the Wizard.

DSL Modems

Connection Type	Details	Data Required
PPPoE	You connect to the ISP only when required. The IP address is allocated automatically.	Username and password. Note that this is the Username and password for Internet access , not for E-mail.
PPTP	Mainly used in Europe. You connect to the ISP only when required.	<ul style="list-style-type: none"> • PPTP Server IP Address. • User name and password. • Your IP Address Check if were you allocated an IP Address by your ISP. <ul style="list-style-type: none"> • If so, select "Fixed IP address" in the Wizard, and enter the details provided by your ISP. • Otherwise, select "Dynamic IP address" in the Wizard.

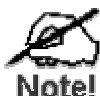

Note!

If your ISP currently requires using PPPoE client software on your PC, this software is no longer required and should be disabled or uninstalled.

Other Modems (e.g. Satellite Broadband)

Data	Details	Check
IP Address	<p>There are 2 systems used:</p> <ul style="list-style-type: none"> • Dynamic -Your IP Address is allocated automatically, when you connect to you ISP. • Static - Your ISP allocates a permanent IP Address to you. 	<p>Were you allocated a specified IP Address?</p> <p>If YES, select "Fixed IP address" in the Wizard, and enter the details provided by your ISP.</p> <p>If NO, select "Dynamic IP address" in the Wizard.</p>

Home Screen

After finishing the Setup Wizard, you will see the *Home* screen. When you connect in the future, you will see this screen when you connect. An example screen is shown below.

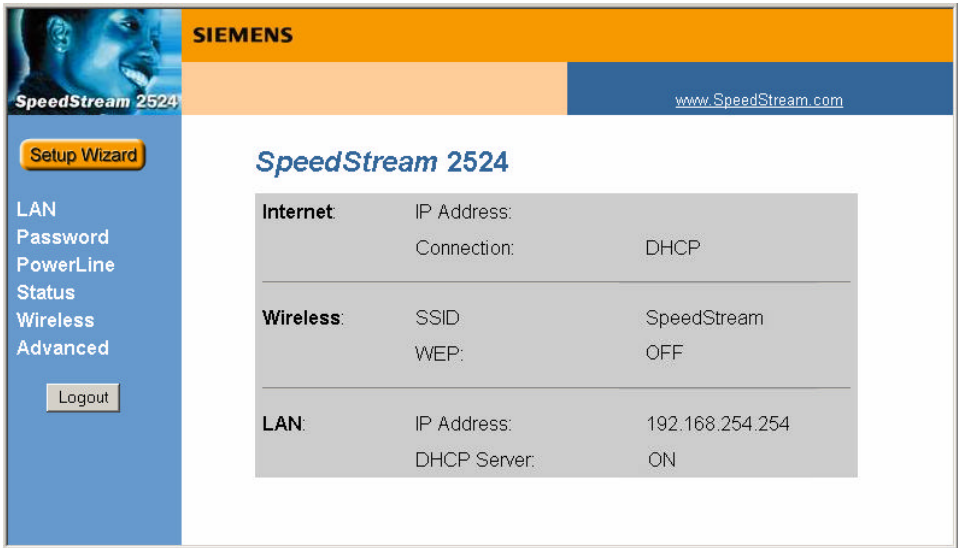

Figure 5: Home Screen

Navigation & Data Input

- Use the menu bar on the left of the screen, and the "Back" button on your Browser, for navigation.
- Changing to another screen without clicking "Save" does NOT save any changes you may have made. You must "Save" before changing screens or your data will be ignored.
- When finished, you should use the "Logout" button, rather than just close your Browser.



On each screen, clicking the "Help" button will display help for that screen.

From any help screen, you can access the list of all help files (help index).

LAN Screen

Use the *LAN* link on the main menu to reach the *LAN* screen. An example screen is shown below:

The screenshot shows the LAN configuration interface. It includes the following elements:

- LAN** (Section Header)
- TCP/IP** (Section Header)
- IP Address:** 192.168.254.254
- Subnet Mask:** 255.255.255.0
- DHCP Server**
- Start IP Address:** [] . [] . [] . 1
- Finish IP Address:** [] . [] . [] . 253
- Buttons:** Save, Cancel, Help

Figure 6: LAN Screen

Data - LAN Screen

TCP/IP	
IP Address	IP address for the SpeedStream Powerline Wireless Router, as seen from the local LAN. Use the default value unless the address is already in use or your LAN is using a different IP address range. In the latter case, enter an unused IP Address from within the range used by your LAN.
Subnet Mask	The default value 255.255.255.0 is standard for small (class "C") networks. For other networks, use the Subnet Mask for the LAN segment to which the SpeedStream Powerline Wireless Router is attached (the same value as the PCs on that LAN segment).
DHCP Server	<ul style="list-style-type: none"> • If Enabled, the SpeedStream Powerline Wireless Router will allocate IP Addresses to PCs (DHCP clients) on your LAN when they start up. The default (and recommended) value is Enabled. • If you are already using a DHCP Server, this setting must be Disabled, and the existing DHCP server must be re-configured to treat the SpeedStream Powerline Wireless Router as the Gateway. See the following section for further details. • The Start IP Address and Finish IP Address fields set the values used by the DHCP server when allocating IP Addresses to DHCP clients. This range also determines the number of DHCP clients supported. <p>See the following section for further details on using DHCP.</p>
Buttons	
Save	Save the data on screen.
Cancel	The "Cancel" button will discard any data you have entered and reload the file from the SpeedStream Powerline Wireless Router.

DHCP

What DHCP Does

A DHCP (Dynamic Host Configuration Protocol) **server** allocates a valid IP address to a DHCP **client** (PC or device) upon request.

- The client request is made when the client device starts up (boots).
- The DHCP Server provides the *Gateway* and *DNS* addresses to the client, as well as allocating an IP Address.
- The SpeedStream Powerline Wireless Router can act as a **DHCP server**.
- Windows 95/98/ME and other non-Server versions of Windows will act as a DHCP **client**. This is the default Windows setting for the TCP/IP network protocol. However, Windows uses the term *Obtain an IP Address automatically* instead of "DHCP Client".
- You must NOT have two (2) or more DHCP Servers on the same LAN segment. (If your LAN does not have other Routers, this means there must only be one (1) DHCP Server on your LAN.)

Using the SpeedStream Powerline Wireless Router's DHCP Server

This is the default setting. The DHCP Server settings are on the *LAN* screen. On this screen, you can:

- Enable or Disable the SpeedStream Powerline Wireless Router's *DHCP Server* function.
- Set the range of IP Addresses allocated to PCs by the DHCP Server function.



Note!

You can assign Fixed IP Addresses to some devices while using DHCP, provided that the Fixed IP Addresses are NOT within the range used by the DHCP Server.

Using another DHCP Server

You can only use one (1) DHCP Server per LAN segment. If you wish to use another DHCP Server, rather than the SpeedStream Powerline Wireless Router's, the following procedure is required.

1. Disable the DHCP Server feature in the SpeedStream Powerline Wireless Router. This setting is on the LAN screen.
2. Configure the DHCP Server to provide the SpeedStream Powerline Wireless Router's IP Address as the *Default Gateway*.

To Configure your PCs to use DHCP

This is the default setting for TCP/IP under Windows 95/98/Me. See *Chapter 4 - Client Configuration* for the procedure to check these settings.

Wireless Configuration

The SpeedStream Powerline Wireless Router is configured to work seamlessly with other SpeedStream wireless products right out of the box.

You may need to reconfigure some wireless settings to ensure that all settings match between wireless devices in the following situations:

- You are also using another manufacturer's wireless products
- The SpeedStream Powerline Wireless Router is being installed in an existing wireless network.

Note:

- Mismatched Wireless settings will prevent successful Powerline network connections between devices.
- The default Wireless settings are listed below. To use the Wireless Access Point in the SpeedStream Powerline Wireless Router, each Wireless Station must have compatible settings.

Mode	On each PC, the mode must be set to <i>Infrastructure</i> .
SSID (ESSID)	This must match the value used on the SpeedStream Powerline Wireless Router. The default value is SpeedStream Note! The SSID is case sensitive.
WEP	By default, WEP on the SpeedStream Powerline Wireless Router is disabled . <ul style="list-style-type: none"> • If WEP remains disabled on the SpeedStream Powerline Wireless Router, all stations must have WEP disabled. • If WEP is enabled on the SpeedStream Powerline Wireless Router, each station must use the same settings as the SpeedStream Powerline Wireless Router.

Wireless Screen

To change the SpeedStream Powerline Wireless Router's default settings for the Wireless Access Point feature, use the *Wireless* link on the main menu to reach the ***Wireless*** screen. An example screen is shown below.

Wireless

Identification

Regulatory Domain: USA

Station Name: SCOFFB01

SSID (Service Set Identifier)

Options

Channel No:

[WEP](#) data encryption: Off

Access Point

Allow **LAN** access by:

ALL Wireless stations

Selected Wireless stations only

Allow **Internet** access by:

ALL Wireless stations

Selected Wireless stations only

Figure 7: Wireless Screen

Data - Wireless Screen

Identification	
Regulatory Domain	It is illegal to use this device in any location outside of the regulatory domain.
Station name	<p>This is the same as the "Device Name" for the SpeedStream Powerline Wireless Router.</p> <p>On your PC, some Wireless status screens may display this name as the name of the Access Point in use.</p>
SSID (ESSID)	<ul style="list-style-type: none"> If using an ESS (Extended Service Set, with multiple access points) this ID is called an ESSID (Extended Service Set Identifier). To communicate, all Wireless stations should use the same SSID/ESSID.
Options	
Channel No.	<ul style="list-style-type: none"> Select the Channel you wish to use on your Wireless LAN. If you experience interference (shown by lost connections and/or slow data transfers) you may need to experiment with different channels to see which is the best. If using multiple Access Points, adjacent Access Points should use different Channels to reduce interference.

WEP data encryption	<ul style="list-style-type: none">• WEP (Wired Equivalent Privacy) status will display "Enabled" or "Disabled", depending on whether WEP is being used. If used, data is Encrypted before being transmitted, making communication more secure.• Click the "Configure WEP" button to access the WEP sub-screen, and view or change the WEP settings.
Access Point	
Allow LAN access by ...	<ul style="list-style-type: none">• All Wireless Stations - All wireless stations can use the access point to access your LAN.• Selected Wireless stations only - Only selected wireless stations can access your LAN. To select the required wireless stations, click the "Select Stations" button.
Allow Internet access by ...	<ul style="list-style-type: none">• All Wireless Stations - All wireless stations can use the access point to access the Internet.• Selected Wireless stations only - Only selected wireless stations can use the access point to access the Internet. To select the required wireless stations, click the "Select Stations" button.
Buttons	
Configure WEP	Click this button to view the WEP sub-screen. See the following section for more details.
Select Stations	Click this button to select the required PCs.
Save	Save the data on screen.
Cancel	The "Cancel" button will discard any data you have entered since the last "Save" operation.

WEP Screen

This screen is accessed by clicking the "Configure WEP" button on the *Wireless* screen. An example WEP screen is shown below. Note that in IE, the "Key Table" is only displayed when required.

Figure 8: WEP Screen

Data - WEP Screen

WEP Data Encryption	
Authentication Type	Select the appropriate value - "Open System" or "Shared Key". Check your Wireless card's documentation to see what method to use. Some Wireless cards do not support both methods.
Encryption	<p>Off</p> <ul style="list-style-type: none"> If OFF (default), data is NOT encrypted before being transmitted. <p>64 Bit Encryption</p> <ul style="list-style-type: none"> If selected, data is encrypted, using the default key, before being transmitted. The receiving station must be set to use 64 Bit Encryption, and have the same Key value in the same position in its key table. Otherwise, it will not be able to decrypt the data. Default Key - select the key you wish to be the default. Transmitted data is ALWAYS encrypted using the Default Key; the other Keys are for decryption only. Key Table: <ul style="list-style-type: none"> This table is used when Encrypting and Decrypting data. All stations, including this Access Point, always transmit data encrypted using their default key. The key number (1, 2, 3, 4) is also transmitted. The receiving station will use the key number (1, 2, 3, 4) to determine which key value to use for decryption. If the key value does not match the transmitting station, decryption will fail. The easiest way to ensure there are no problems is to have every Station, including the Access Point, use the same key table (all entries identical).

	<p>128 Bit Encryption</p> <ul style="list-style-type: none">• If selected, data is encrypted using the key before being transmitted. The receiving station must be set to use 128 Bit Encryption, and have the same Key value. Otherwise, it will not be able to decrypt the data.• Keys - Enter the key values you wish to use. Other stations must have the same key values.
<p>Passphrase</p>	<p>To generate a set of keys from a word or phrase:</p> <ol style="list-style-type: none">1. Select the type of key required (64 Bit or 128 Bit)2. Enter the word or phrase in the "Passphrase" field.3. Click the "Generate Keys" button.4. The screen will refresh with the key values inserted.

Powerline Configuration

The SpeedStream Powerline Wireless Router is configured to work seamlessly with other SpeedStream Powerline products right out of the box.

You may need to reconfigure some Powerline settings to ensure that all settings match between Powerline devices in the following situations:

- You are also using another manufacturer's Powerline products
- The SpeedStream Powerline Wireless Router is being installed in an existing Powerline network.

Note:

- Mismatched Powerline settings will prevent successful Powerline network connections between Powerline stations.
- The default Powerline Network Password is *SpeedStream*
- 56-bit DES encryption is always enabled for Powerline data security, changing the Powerline Network Password is recommended for added protection.

Powerline Screen

This screen can be reached via the Powerline link on the main menu.

This screen allows you to set the Powerline Network Password for the router as well as other Powerline devices on your network. All Powerline devices must use the same Powerline Network Password to communicate with each other.

You can also use this screen to assign a new Network Password to other Powerline stations on your LAN. To do this:

1. Enter the default passcodes of any Powerline stations on your LAN.
Each Powerline station has a unique Passcode/Password in the format xxxx-xxxx-xxxx-xxxx, usually shown on a label on the rear or base of the Powerline device.
2. In the "Other Stations" list, select the stations you wish to assign the Network Password to.
3. Click the "Set Network Password" Button.
4. A confirmation message will appear confirming the success of the password change for each device. An error message will appear if any device is not able to be reset to the new network password.

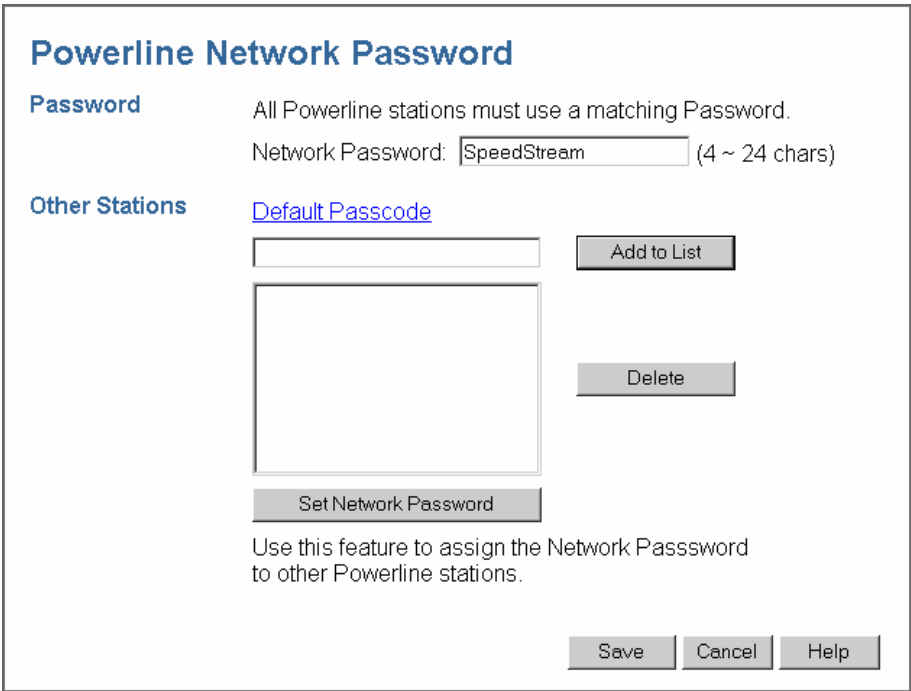

Figure 9: Powerline Screen

Data - Powerline Screen

Powerline Data Encryption	
Password	<p>The <i>Powerline Network Password</i> must be set to match other devices on your Powerline network to allow them to communicate with one another.</p> <p>The default value is <i>SpeedStream</i></p>
Other Stations	<p>This feature allows you to assign the <i>Powerline Network Password</i> to other Powerline stations on your LAN. Each Powerline station must be identified by its <i>Default Passcode</i>, usually indicated by a sticker on the bottom or back side of the Powerline device. Other Powerline devices must be connected to your powerline network and functioning properly before their network password can be reset using this function.</p> <ul style="list-style-type: none"> • Default Passcode - To add a station to the list, enter its Default Passcode in this field, and click the <i>Add to List</i> button. • Delete Button - Clicking this will delete selected stations from the list. • Set Network Password Button - Clicking this will assign the current <i>Powerline Network Password</i> to all selected stations. You can select multiple stations by holding the CTRL key while selecting. (On the Macintosh, use SHIFT instead of CTRL.)

Password Screen

The password screen allows you to assign a password to the SpeedStream Powerline Wireless Router. This password limits access to the configuration interface of your router.

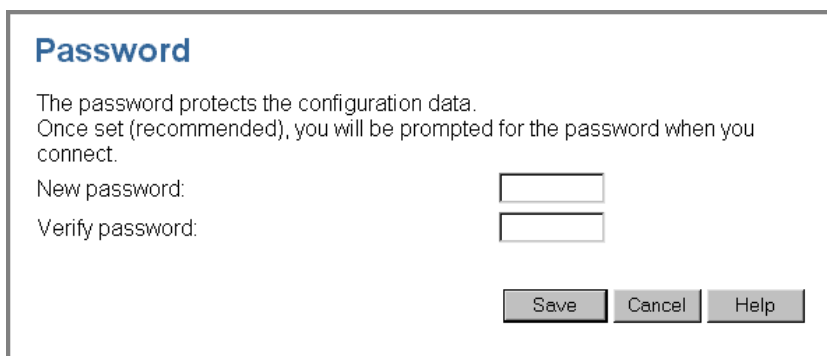

The screenshot shows a window titled "Password". Inside, there is a heading "Password" followed by explanatory text: "The password protects the configuration data. Once set (recommended), you will be prompted for the password when you connect." Below this, there are two input fields: "New password:" and "Verify password:". At the bottom right, there are three buttons: "Save", "Cancel", and "Help".

Figure 10: Password Screen

Once you have assigned a password to the SpeedStream Powerline Wireless Router (on the *Password* screen above) you will be prompted for the password when you connect, as shown below. (If no password has been set, this dialog will not appear.)

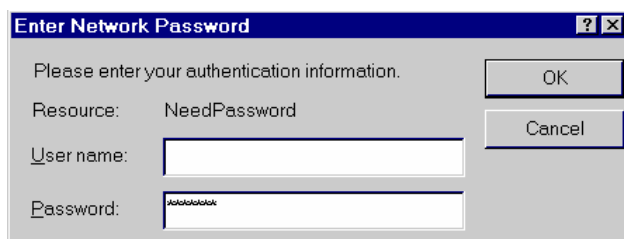

The screenshot shows a dialog box titled "Enter Network Password". It contains the text "Please enter your authentication information." and "Resource: NeedPassword". There are two input fields: "User name:" (which is blank) and "Password:" (which contains masked characters). On the right side, there are two buttons: "OK" and "Cancel".

Figure 11: Password Dialog

- Leave the "User Name" blank.
- Enter the password for the SpeedStream Powerline Wireless Router, as set on the *Password* screen above.

Chapter 4

PC Configuration



This Chapter details the PC Configuration required for each PC on the local LAN.

Overview

For each PC, the following may need to be configured:

- TCP/IP network settings
- Wireless settings
- Internet Access configuration
- Printer configuration

Windows Clients

This section describes how to configure Windows clients for:

- Internet access via the SpeedStream Powerline Wireless Router
- Sharing the Printer connected to the SpeedStream Powerline Wireless Router.

The first step is to check the PC's TCP/IP settings.

The SpeedStream Powerline Wireless Router uses the TCP/IP network protocol for all functions, so it is essential that the TCP/IP protocol be installed and configured on each PC.

TCP/IP Settings - Overview

If using the default SpeedStream Powerline Wireless Router settings, and the default Windows TCP/IP settings, no changes need to be made.

- By default, the SpeedStream Powerline Wireless Router will act as a DHCP Server, automatically providing a suitable IP Address (and related information) to each PC when the PC boots.
- For all non-Server versions of Windows, the default TCP/IP setting is to act as a DHCP client.

If using a Fixed (specified) IP address, the following changes are required:

- The *Gateway* must be set to the IP address of the SpeedStream Powerline Wireless Router
- The *DNS* should be set to the address provided by your ISP.



Note!

If your LAN has a Router, the LAN Administrator must re-configure the Router itself. Refer to *Chapter 7 - Routing* for details.

Checking TCP/IP Settings - Windows 9x/ME:

1. Select *Control Panel - Network*. You should see a screen like the following:

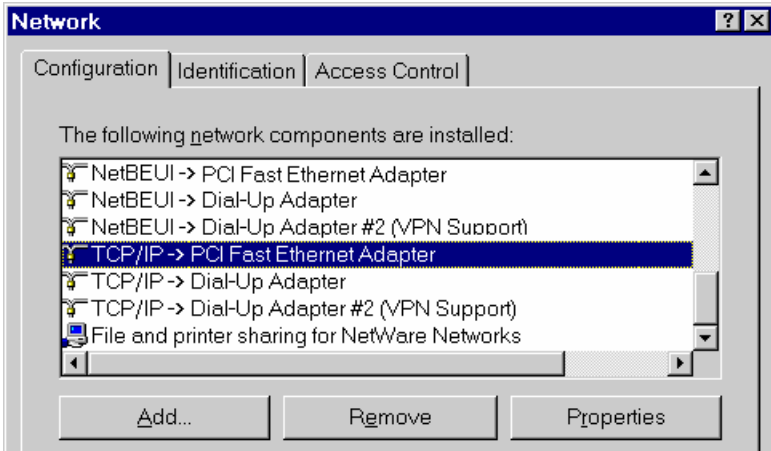

Figure 12: Network Configuration

2. Select the *TCP/IP* protocol for your network card.
3. Click on the *Properties* button. You should then see a screen like the following.

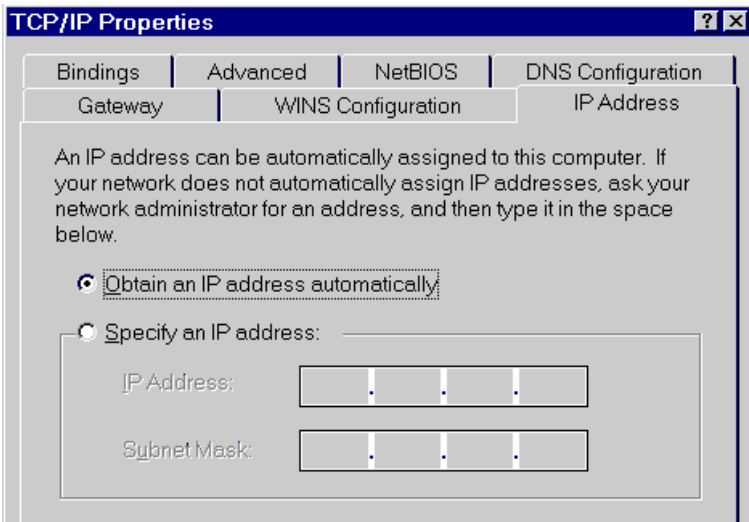

Figure 13: IP Address (Win 95)

Ensure your TCP/IP settings are correct, as follows:

Using DHCP

To use DHCP, select the radio button *Obtain an IP Address automatically*. This is the default Windows settings.

Restart your PC to ensure it obtains an IP Address from the SpeedStream Powerline Wireless Router.

Using "Specify an IP Address"

- If your PC is already configured, do NOT change the settings on the IP Address tab shown in Figure 13 above.

- On the *Gateway* tab, enter the SpeedStream Powerline Wireless Router's IP address in the *New Gateway* field and click *Add*. Your LAN administrator can advise you of the IP Address they assigned to the SpeedStream Powerline Wireless Router.

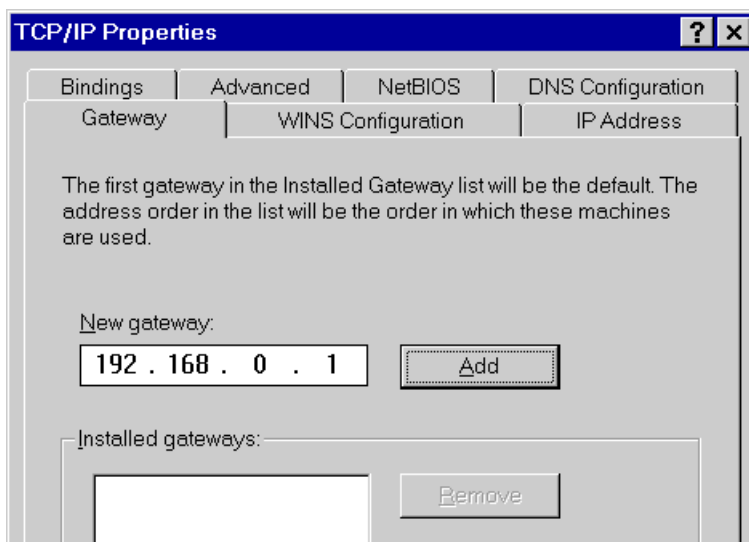

Figure 14: Gateway Tab

- On the *DNS Configuration* tab, ensure *Enable DNS* is selected. If the *DNS Server Search Order* list is empty, enter the DNS address provided by your ISP in the fields beside the *Add* button, then click *Add*.

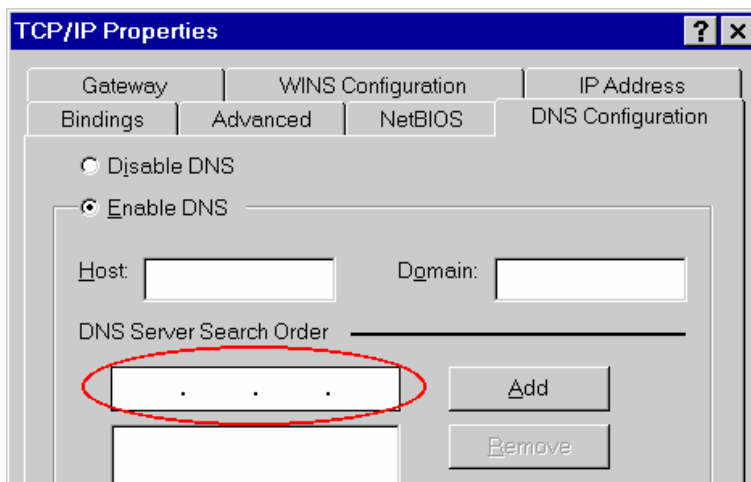

Figure 15: DNS Tab (Win 95/98)

Checking TCP/IP Settings - Windows NT4.0

1. Select *Control Panel - Network*, and, on the *Protocols* tab, select the TCP/IP protocol, as shown below.

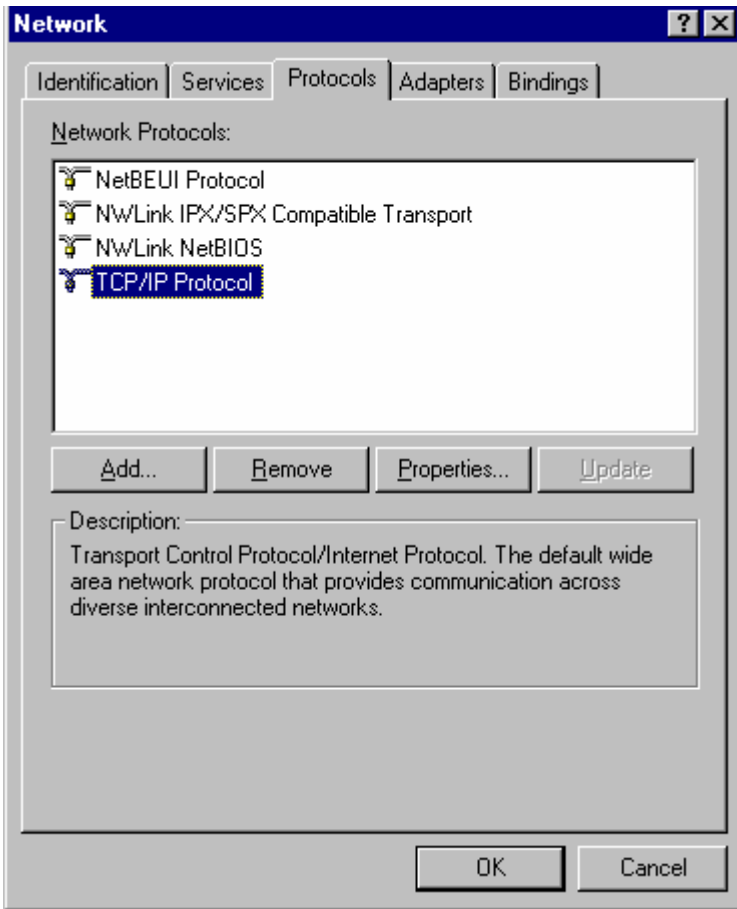

Figure 16: Windows NT4.0 - TCP/IP

2. Click the *Properties* button to see a screen like the one below.

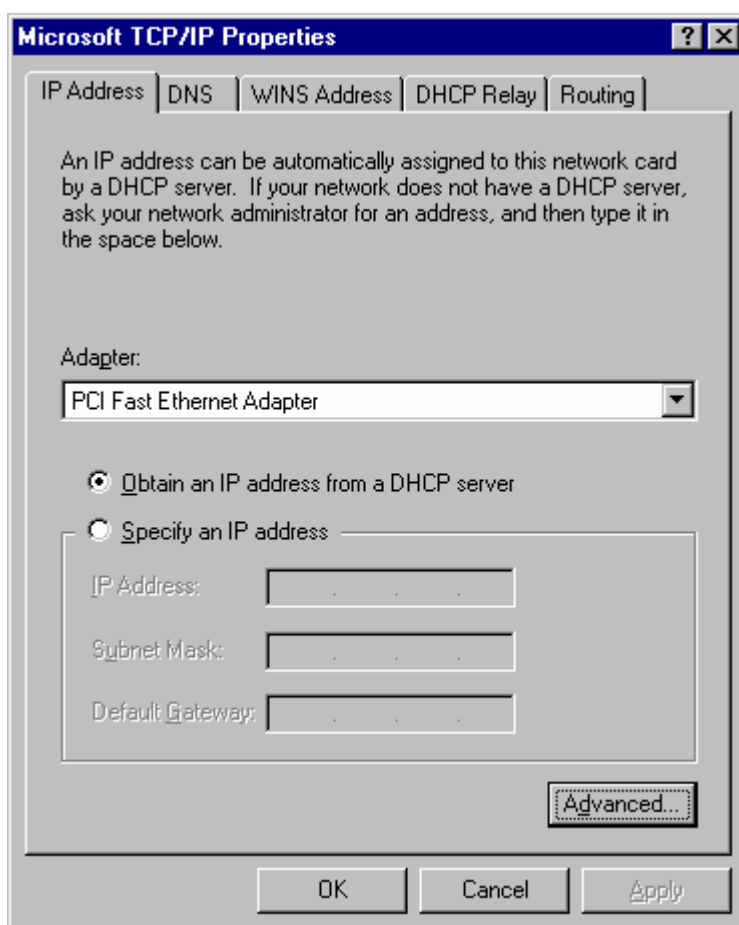

Figure 17: Windows NT4.0 - IP Address

3. Select the network card for your LAN.
4. Select the appropriate radio button - *Obtain an IP address from a DHCP Server* or *Specify an IP Address*, as explained below.

Obtain an IP address from a DHCP Server

This is the default Windows setting. **Using this method is recommended.** By default, the SpeedStream Powerline Wireless Router will act as a DHCP Server.

Restart your PC to ensure it obtains an IP Address from the SpeedStream Powerline Wireless Router.

Specify an IP Address

If your PC is already configured, check with your network administrator before making the following changes.

1. The *Default Gateway* must be set to the IP address of the SpeedStream Powerline Wireless Router. To set this:
 - Click the *Advanced* button on the screen above.
 - On the following screen, click the *Add* button in the *Gateways* panel, and enter the SpeedStream Powerline Wireless Router's IP address, as shown in Figure 18 below.
 - If necessary, use the *Up* button to make the SpeedStream Powerline Wireless Router the first entry in the *Gateways* list.

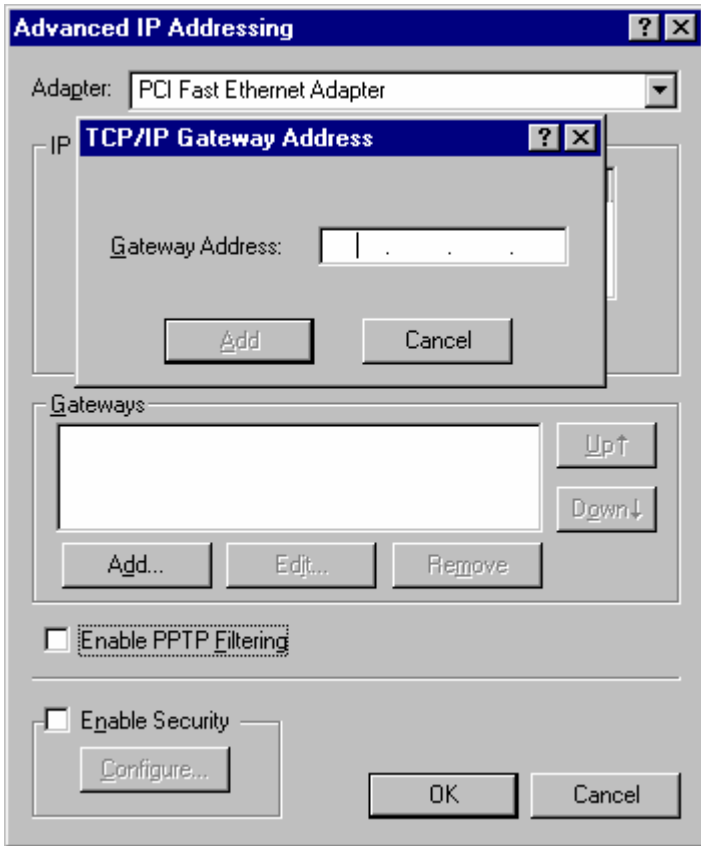

Figure 18 - Windows NT4.0 - Add Gateway

2. The DNS should be set to the address provided by your ISP, as follows:
 - Click the DNS tab.
 - On the DNS screen, shown below, click the *Add* button (under *DNS Service Search Order*), and enter the DNS provided by your ISP.

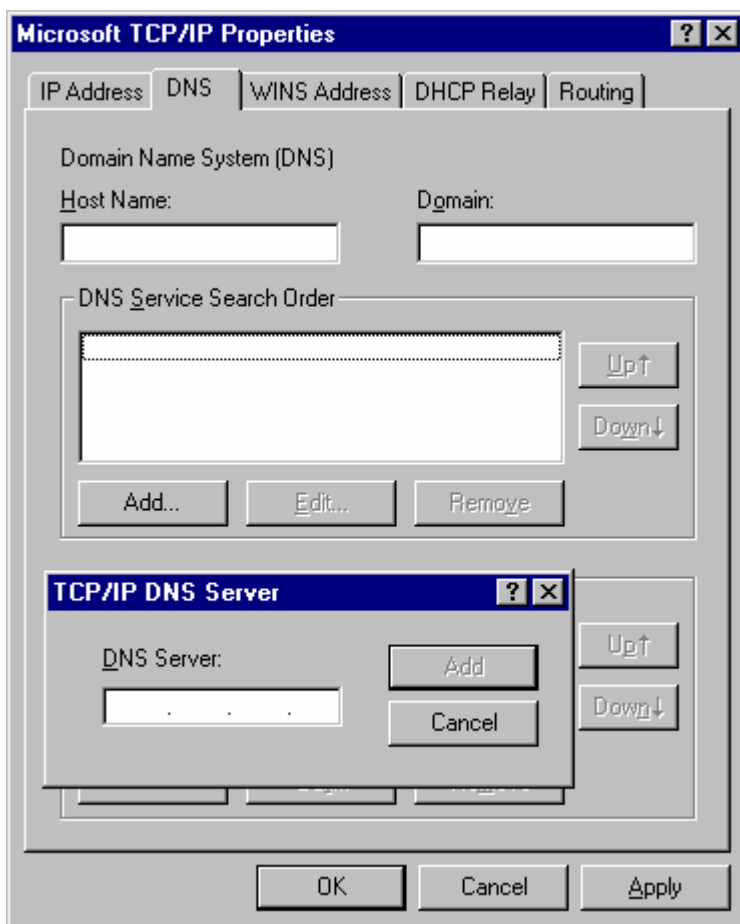

Figure 19: Windows NT4.0 - DNS

Checking TCP/IP Settings - Windows 2000:

1. Select *Control Panel - Network and Dial-up Connection*.
2. Right click the *Local Area Connection* icon and select *Properties*. You should see a screen like the following:

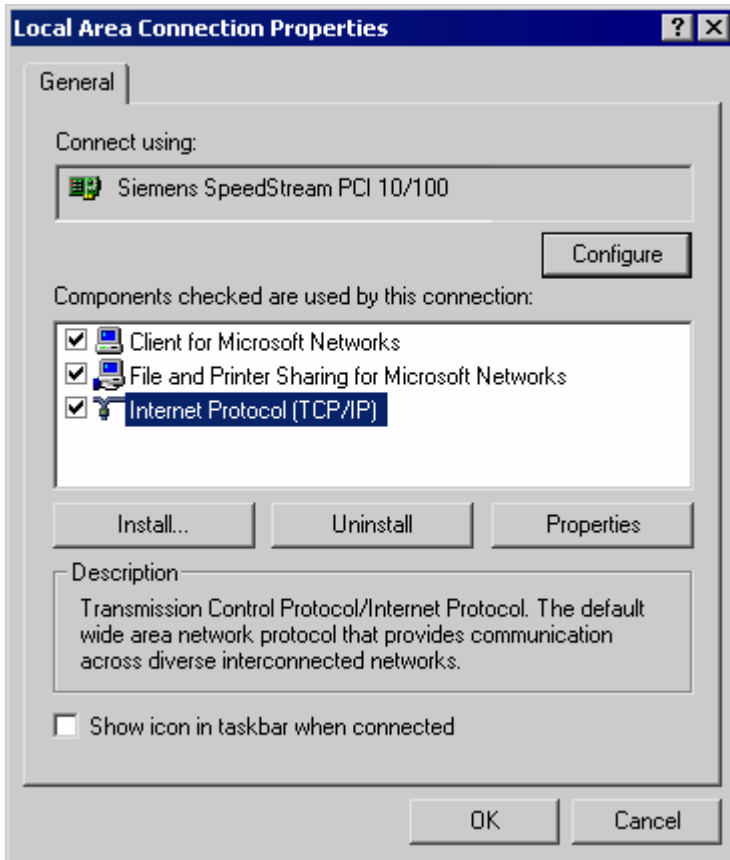

Figure 20: Network Configuration (Win 2000)

3. Select the *TCP/IP* protocol for your network card.
4. Click on the *Properties* button. You should then see a screen like the following.

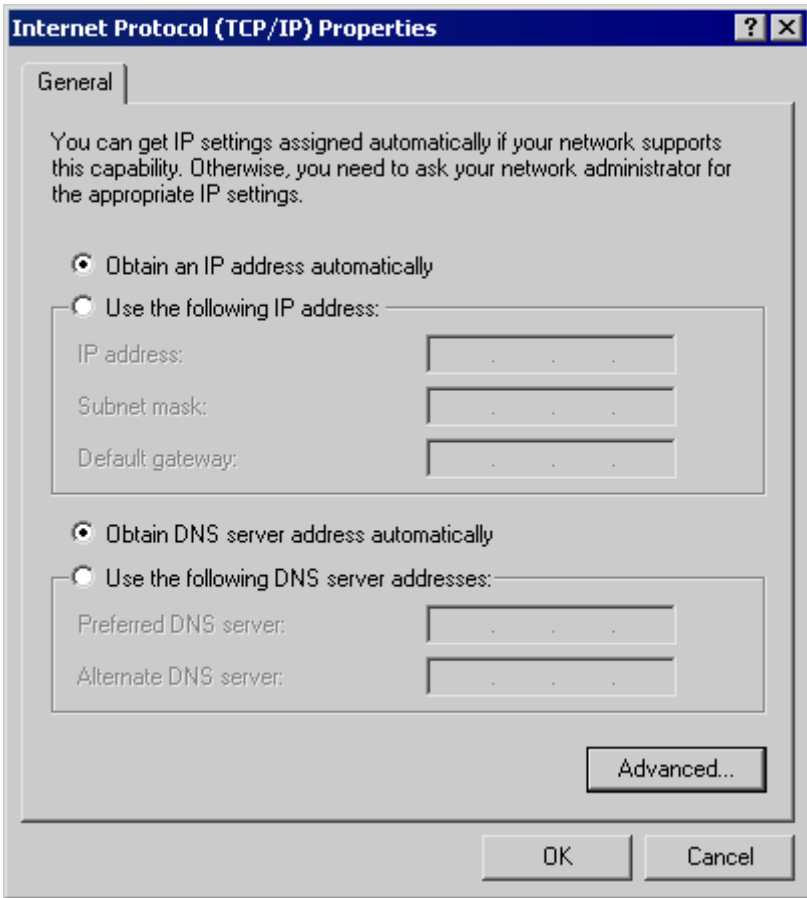

Figure 21: TCP/IP Properties (Win 2000)

5. Ensure your TCP/IP settings are correct:

Using DHCP

To use DHCP, select the radio button *Obtain an IP Address automatically*. This is the default Windows settings.

Restart your PC to ensure it obtains an IP Address from the SpeedStream Powerline Wireless Router.

Using a fixed IP Address ("Use the following IP Address")

If your PC is already configured, check your ISP's documentation before making the following changes.

- Enter the SpeedStream Powerline Wireless Router's IP address in the *Default gateway* field and click *OK*.
- If the *DNS Server* fields are empty, select *Use the following DNS server addresses*, and enter the DNS address or addresses provided by your ISP, then click *OK*.

Checking TCP/IP Settings - Windows XP:

1. Select *Control Panel - Network Connection*.
2. Right click the *Local Area Connection* and choose *Properties*. You should see a screen like the following:

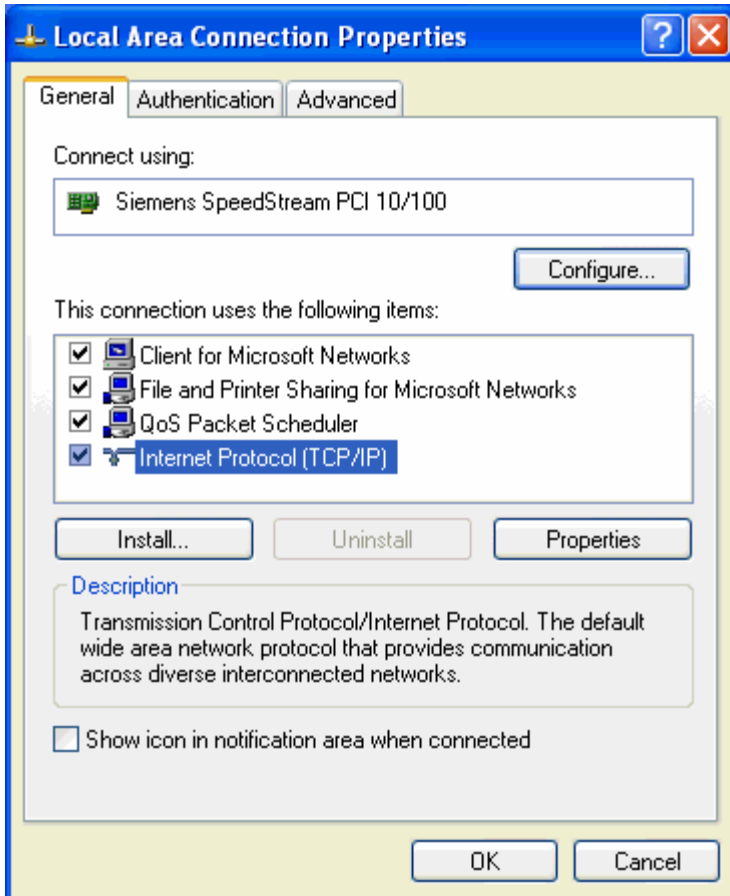

Figure 22: Network Configuration (Windows XP)

3. Select the *TCP/IP* protocol for your network card.
4. Click on the *Properties* button. You should then see a screen like the following.

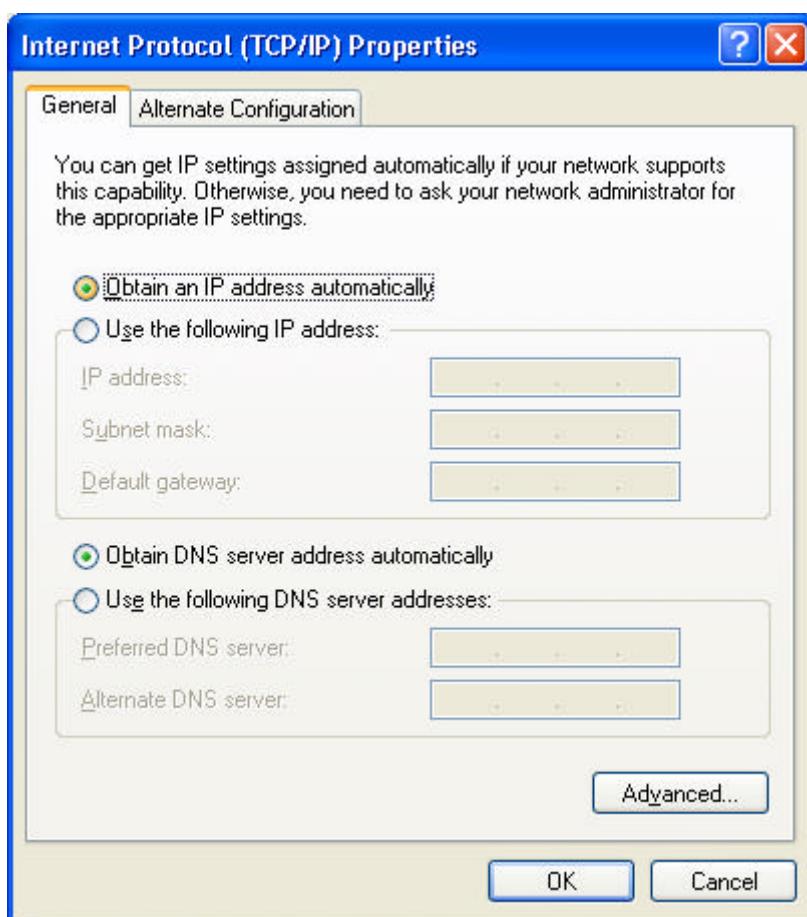

Figure 23: TCP/IP Properties (Windows XP)

5. Ensure your TCP/IP settings are correct.

Using DHCP

To use DHCP, select the radio button *Obtain an IP Address automatically*. This is the default Windows settings.

Restart your PC to ensure it obtains an IP Address from the SpeedStream Powerline Wireless Router.

Using a fixed IP Address ("Use the following IP Address")

- If your PC is already configured, do NOT change the settings on the screen shown in Figure 23 above, unless advised to do so by your network administrator.
- You can enter the SpeedStream Powerline Wireless Router's IP address in the *Default gateway* field and click *OK*. Your LAN administrator can advise you of the IP Address they assigned to the SpeedStream Powerline Wireless Router.
- If the *DNS Server* fields are empty, select *Use the following DNS server addresses*, and enter the DNS address or addresses provided by your ISP, then click *OK*.

Internet Access

To configure your PCs to use the SpeedStream Powerline Wireless Router for Internet access:

- Ensure that the DSL modem, Cable modem, or other permanent connection is functional.
- Use the following procedure to configure your Browser to access the Internet via the LAN, rather than by a Dial-up connection.

For Windows 9x/2000

1. Select *Start Menu - Settings - Control Panel - Internet Options*.
2. Select the *Connection* tab, and click the *Setup* button.
3. Select "I want to set up my Internet connection manually, or I want to connect through a local area network (LAN)" and click *Next*.
4. Select "I connect through a local area network (LAN)" and click *Next*.
5. Ensure all of the boxes on the following *Local area network Internet Configuration* screen are **unchecked**.
6. Check the "No" option when prompted "Do you want to set up an Internet mail account now?".
7. Click *Finish* to close the Internet Connection Wizard.
Setup is now completed.

For Windows XP

1. Select *Start Menu - Control Panel - Network and Internet Connections*.
2. Select *Set up or change your Internet Connection*.
3. Select the *Connection* tab, and click the *Setup* button.
4. Cancel the pop-up "Location Information" screen.
5. Click *Next* on the "New Connection Wizard" screen.
6. Select "Connect to the Internet" and click *Next*.
7. Select "Set up my connection manually" and click *Next*.
8. Check "Connect using a broadband connection that is always on" and click *Next*.
9. Click *Finish* to close the New Connection Wizard.
Setup is now completed.

Accessing AOL

To access AOL (America On Line) through the SpeedStream Powerline Wireless Router, the *AOL for Windows* software must be configured to use TCP/IP network access, rather than a dial-up connection. The configuration process is as follows:

- Start the *AOL for Windows* communication software. Ensure that it is Version 2.5, 3.0 or later. This procedure will not work with earlier versions.
- Click the *Setup* button.
- Select *Create Location*, and change the location name from "New Locality" to "Broadband Router".
- Click *Edit Location*. Select *TCP/IP* for the *Network* field. (Leave the *Phone Number* blank.)
- Click *Save*, then *OK*.
Configuration is now complete.
- Before clicking "Sign On", always ensure that you are using the "Broadband Router" location.

Macintosh Clients

From your Macintosh, you can access the Internet via the SpeedStream Powerline Wireless Router. The procedure is as follows.

1. Open the TCP/IP Control Panel.
2. Select *Ethernet* from the *Connect via* pop-up menu.
3. Select *Using DHCP Server* from the *Configure* pop-up menu. The DHCP Client ID field can be left blank.
4. Close the TCP/IP panel, saving your settings.

Note:

If using manually assigned IP addresses instead of DHCP, the required changes are:

- Set the *Router Address* field to the SpeedStream Powerline Wireless Router's IP Address.
- Ensure your DNS settings are correct.

Linux Clients

To access the Internet via the SpeedStream Powerline Wireless Router, it is only necessary to set the SpeedStream Powerline Wireless Router as the "Gateway".

Ensure you are logged in as "root" before attempting any changes.

Fixed IP Address

By default, most Unix installations use a fixed IP Address. If you wish to continue using a fixed IP Address, make the following changes to your configuration.

- Set your "Default Gateway" to the IP Address of the SpeedStream Powerline Wireless Router.
- Ensure your DNS (Name server) settings are correct.

To act as a DHCP Client (recommended)

The procedure below may vary according to your version of Linux and X -windows shell.

1. Start your X Windows client.
2. Select *Control Panel - Network*
3. Select the "Interface" entry for your Network card. Normally, this will be called "eth0".
4. Click the *Edit* button, set the "protocol" to "DHCP", and save this data.
5. To apply your changes
 - Use the "Deactivate" and "Activate" buttons, if available.
 - OR, restart your system.

Other Unix Systems

Internet Access

- Ensure the "Gateway" field for your network card is set to the IP Address of the SpeedStream Powerline Wireless Router.

- Ensure your DNS (Name Server) settings are correct.

Wireless Station Configuration

The SpeedStream Powerline Wireless Router is configured to work seamlessly with other SpeedStream wireless products right out of the box.

You may need to reconfigure some wireless settings to ensure that all settings match between wireless devices in the following situations:

- You are also using another manufacturer's wireless products
- The SpeedStream Powerline Wireless Router is being installed in an existing wireless network.

Note:

- Mismatched Wireless settings will prevent successful Powerline network connections between devices.
- The default Wireless settings are listed below. To use the Wireless Access Point in the SpeedStream Powerline Wireless Router, each Wireless Station must have compatible settings.

Mode	On each PC, the mode must be set to <i>Infrastructure</i> .
SSID (ESSID)	This must match the value used on the SpeedStream Powerline Wireless Router. The default value is SpeedStream Note! The SSID is case sensitive.
WEP	By default, WEP on the SpeedStream Powerline Wireless Router is disabled . <ul style="list-style-type: none"> • If WEP remains disabled on the SpeedStream Powerline Wireless Router, all stations must have WEP disabled. • If WEP is enabled on the SpeedStream Powerline Wireless Router, each station must use the same settings as the SpeedStream Powerline Wireless Router.

Powerline Configuration

The SpeedStream Powerline Wireless Router is configured to work seamlessly with other SpeedStream Powerline products right out of the box.

All Powerline devices must use the same Powerline Network Password

If necessary, reconfigure some devices to ensure this.

Note:

- For the SpeedStream Powerline Wireless Router, the default Powerline Network Password is *SpeedStream*
- 56-bit DES encryption is always enabled for Powerline data security.

Chapter 5

Operation and Status



This Chapter details the operation of the SpeedStream Powerline Wireless Router and the status screens.

Operation

Once both the SpeedStream Powerline Wireless Router and the PCs are configured, operation is automatic.

However, there are some situations where additional Internet configuration may be required:

- If using Internet-based *Conferencing & Telephony* applications, it may be necessary to specify which PC receives an incoming connection. Refer to *Chapter 6 - Advanced Features* for further details.
- Applications that use non-standard connections or port numbers may be blocked by the SpeedStream Powerline Wireless Router's built-in firewall. You can define such applications as *Special Applications* to allow them to function normally. Refer to *Chapter 6 - Advanced Features* for further details.
- Some non-standard applications may require use of the *DMZ* feature. Refer to *Chapter 6 - Advanced Features* for further details.

Status Screen

Use the *Status* link on the main menu to view this screen.

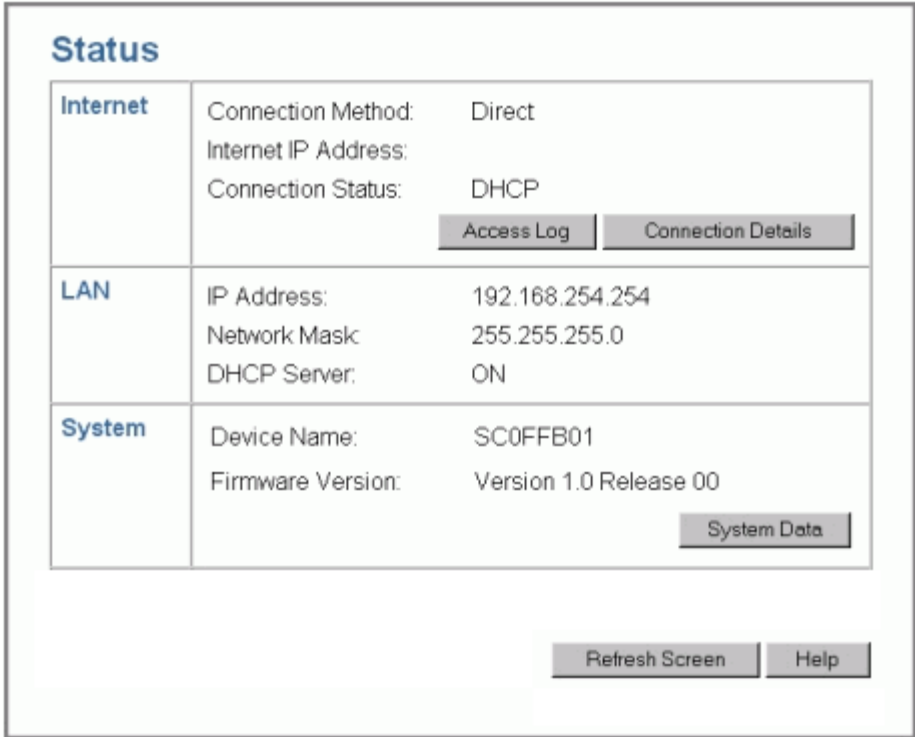

Figure 24: Status Screen

Data - Status Screen

Internet	
Connection Method	This indicates the current connection method, as set in the Setup Wizard.
Internet IP Address	This IP Address is allocated by the ISP (Internet Service Provider).
Connection Status	<p>Current connection status:</p> <ul style="list-style-type: none"> • OK • No connection • Error <p>If there is an error, you can click the "Connection Details" button to find out more information.</p>
"Access Log" Button	<p>Click this button to open a sub-window and view details of outgoing connections to the Internet. The log contains the following data:</p> <ul style="list-style-type: none"> • Date/Time - When the connection was first established. • Source IP Address - The IP Address of the local PC requesting the Internet connection.

	<ul style="list-style-type: none"> • Destination - The Internet address which was requested. If the <i>URL Filter</i> is enabled, this address will be shown as a URL. Otherwise, the IP address will be displayed. • Blocked - If the request was blocked by the <i>URL Filter</i> function, this will display "Yes". Otherwise, it will be blank.
"Connection Details" Button	Click this button to open a sub-window and view a detailed description of the current connection. Depending on the type of connection, a "log" may also be available.
LAN	
IP Address	The IP Address of the SpeedStream Powerline Wireless Router.
Network Mask	The Network Mask (Subnet Mask) for the IP Address above.
DHCP Server	<p>This shows the status of the DHCP Server function - either "Enabled" or "Disabled".</p> <p>For additional information about the PCs on your LAN, and the IP addresses allocated to them, use the <i>Network Clients</i> option on the <i>Advanced</i> menu.</p>
System	
Device Name	This displays the current name of the SpeedStream Powerline Wireless Router.
Firmware Version	The current version of the firmware installed in the SpeedStream Powerline Wireless Router.
"System Data" Button	Clicking this button will open a Window that lists all system details and settings.
Buttons	
Connection Details	View the details of the current Internet connection. The sub-screen displayed will depend on the connection method used. See the following sections for details of each sub-screen.
Access Log	View details of outgoing connections to the internet.
System Data	Display all system information in a sub-window.
Refresh Screen	Update the data displayed on screen.

Connection Status - PPPoE

If using PPPoE (PPP over Ethernet), a screen like the following example will be displayed when the "Connection Details" button is clicked.

Connection Status - PPPoE

Connection

Physical Address: 00-c0-02-0f-fb-02
 IP Address:
 Network Mask:
 PPPoE Link Status: OFF

Connection Log

```
068:Reset physical connection
067:stop PPP
066:try to hang up
065:Error: Connection to Server lost.
064:Error: PPP connection failed.
063:Send 0:CO:2:F:FA:15 FF:FF:FF:FF:FF:FF
```

Connect and Disconnect buttons should only be needed if the setting "Connect automatically, as required" is Disabled.

Figure 25: PPPoE Status Screen

Data - PPPoE Status Screen

Connection	
Physical Address	The hardware address of this device, as seen by remote devices on the Internet. (This is different to the hardware address seen by devices on the local LAN.)
IP Address	The IP Address of this device, as seen by Internet users. This address is allocated by your ISP (Internet Service Provider).
Network Mask	The Network Mask associated with the IP Address above.
PPPoE Link Status	<p>This indicates whether or not the connection is currently established.</p> <ul style="list-style-type: none"> • If the connection does not exist, the "Connect" button can be used to establish a connection. • If the connection currently exists, the "Disconnect" button can be used to break the connection.
Connection Log	
Connection Log	<ul style="list-style-type: none"> • The Connection Log shows status messages relating to the existing connection.

	<ul style="list-style-type: none"> • The most common messages are listed in the table below. • The "Clear Log" button will restart the Log, while the Refresh button will update the messages shown on screen.
Buttons	
Connect	If not connected, establish a connection to your ISP.
Disconnect	If connected to your ISP, hang up the connection.
Clear Log	Delete all data currently in the Log. This will make it easier to read new messages.
Refresh	Update the data on screen.

Connection Log Messages

Message	Description
Connect on Demand	Connection attempt has been triggered by the "Connect automatically, as required" setting.
Manual connection	Connection attempt started by the "Connect" button.
Reset physical connection	Preparing line for connection attempt.
Connecting to remote server	Attempting to connect to the ISP's server.
Remote Server located	ISP's Server has responded to connection attempt.
Start PPP	Attempting to login to ISP's Server and establish a PPP connection.
PPP up successfully	Able to login to ISP's Server and establish a PPP connection.
Idle time-out reached	The connection has been idle for the time period specified in the "Idle Time-out" field. The connection will now be terminated.
Disconnecting	The current connection is being terminated, due to either the "Idle Time-out" above, or "Disconnect" button being clicked.
Error: Remote Server not found	ISP's Server did not respond. This could be a Server problem, or a problem with the link to the Server.
Error: PPP Connection failed	Unable to establish a PPP connection with the ISP's Server. This could be a login problem (name or password) or a Server problem.
Error: Connection to Server lost	The existing connection has been lost. This could be caused by a power failure, a link failure, or Server failure.
Error: Invalid or unknown packet type	The data received from the ISP's Server could not be processed. This could be caused by data corruption (from a bad link), or the Server using a protocol that is not supported by this device.

Connection Status - PPTP

If using PPTP (Peer-to-Peer Tunneling Protocol), a screen like the following example will be displayed when the "Connection Details" button is clicked.

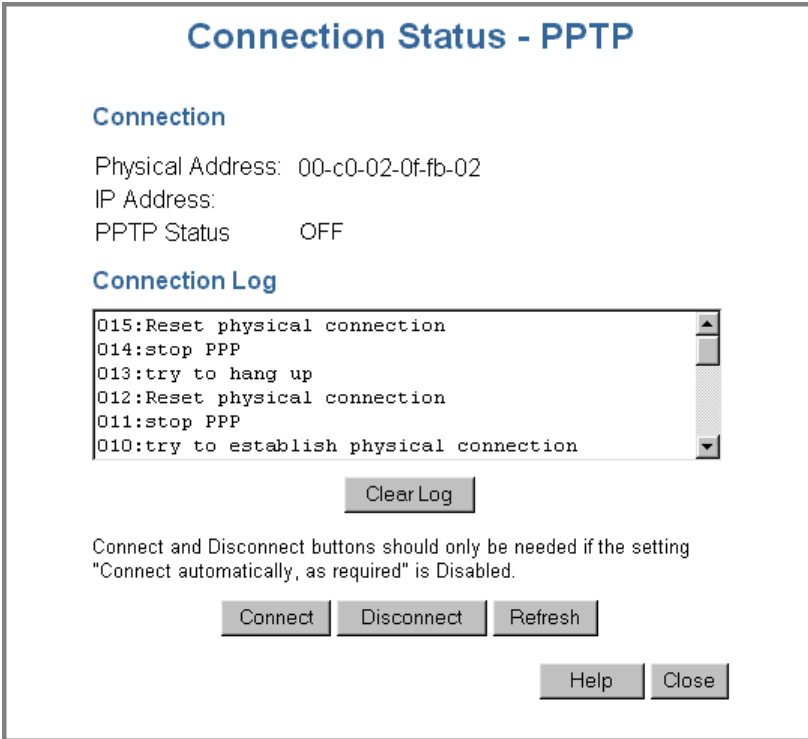

Figure 26: PPTP Status Screen

Data - PPTP Status Screen

Connection	
Physical Address	The hardware address of this device, as seen by remote devices on the Internet. (This is different to the hardware address seen by devices on the local LAN.)
IP Address	The IP Address of this device, as seen by Internet users. This address is allocated by your ISP (Internet Service Provider).
PPTP Status	This indicates whether or not the connection is currently established. <ul style="list-style-type: none"> • If the connection does not exist, the "Connect" button can be used to establish a connection. • If the connection currently exists, the "Disconnect" button can be used to break the connection.
Connection Log	
Connection Log	<ul style="list-style-type: none"> • The Connection Log shows status messages relating to the existing connection. • The "Clear Log" button will restart the Log, while the Refresh button will update the messages shown on screen.

Buttons	
Connect	If not connected, establish a connection to your ISP.
Disconnect	If connected to your ISP, hang up the connection.
Clear Log	Delete all data currently in the Log. This will make it easier to read new messages.
Refresh	Update the data on screen.

Connection Details - Fixed/Dynamic IP Address

If your access method is neither PPPoE nor PPTP, a screen like the following example will be displayed when the "Connection Details" button is clicked.

Connection Details

Internet

Physical Address: 00-c0-02-0f-fb-02
IP Address:
Network Mask:
Default Gateway:

DNS IP Address: 139.175.252.16

DHCP Client: ON
Lease obtained: 0 days,0 hrs,0 minutes
Remaining lease time: 0 days,0 hrs,0 minutes

Figure 27: Connection Status Screen

Data - Connection Details Screen

Internet	
Physical Address	The hardware address of this device, as seen by remote devices on the Internet. (This is different to the hardware address seen by devices on the local LAN.)
IP Address	The IP Address of this device, as seen by Internet users. This address is allocated by your ISP (Internet Service Provider).
Network Mask	The Network Mask associated with the IP Address above.
Default Gateway	The IP Address of the remote Gateway or Router associated with the IP Address above.
DNS IP Address	The IP Address of the Domain Name Server that is currently used.

DHCP Client	<p>This will show "Enabled" or "Disabled", depending on whether or not this device is functioning as a DHCP client.</p> <p>If "Enabled" the "Remaining lease time" field indicates when the IP Address allocated by the DHCP Server will expire. The lease is automatically renewed on expiry; use the "Renew" button if you wish to manually renew the lease immediately.</p>
Buttons	
<p>Release/Renew</p> <p>Button will display</p> <p>EITHER</p> <p>"Release"</p> <p>OR</p> <p>"Renew"</p>	<p>This button is only useful if the IP address shown above is allocated automatically on connection. (Dynamic IP address). Otherwise, it has no effect.</p> <ul style="list-style-type: none"> • If the ISP's DHCP Server has NOT allocated an IP Address for the SpeedStream Powerline Wireless Router, this button will say "Renew". Clicking the "Renew" button will attempt to re-establish the connection and obtain an IP Address from the ISP's DHCP Server. • If an IP Address has been allocated to the SpeedStream Powerline Wireless Router (by the ISP's DHCP Server), this button will say "Release". Clicking the "Release" button will break the connection and release the IP Address.
Refresh	Update the data shown on screen.

Chapter 6

Advanced Features



This Chapter explains when and how to use the SpeedStream Powerline Wireless Router's "Advanced" Features.

Overview

All advanced features are accessed via the **Advanced** menu. The following advanced features are provided.

- Special Applications
- DMZ
- Virtual Servers
- Dynamic DNS
- Remote Management
- Access Control
- Firmware Upgrade using your Web Browser

This chapter contains details of the configuration and use of each of these features.

Note: The screens shown below are identical for all SpeedStream Powerline and Wireless Routers; therefore, some screenshots are shared between multiple user manuals.

Advanced Internet Screen

This screen allows configuration of all advanced features relating to Internet access.

- Conferencing and Telephony applications
- Special Applications
- DMZ
- URL filter

An example screen is shown below.

Advanced Internet

Conferencing & Telephony Select an Application: AOE
H323(CUseeME & MS NetMeeting & TGI Phone)
ICU II (ICU 2)
Internet Phone

Send incoming calls to: Select a PC

Save when finished, not after each change.

Special Applications If an application does not work, you can define it as a Special Application.

Special Applications

DMZ Enable [DMZ](#), using Select a PC

My PC is not listed

URL Filter Enable [URL Filter](#)

Configure URL Filter

Save Cancel Help

Figure 28: Advanced Internet Screen

Conferencing & Telephony

The SpeedStream Powerline Wireless Router supports most applications transparently. But sometimes it is not clear which PC should receive an incoming connection. This problem could arise with the following *Conferencing & Telephony* applications:

- CUseeME
- ICQ
- ICU II (ICU 2)
- Internet Phone
- mIRC
- MS NetMeeting
- Yahoo Messenger

If this problem arises, you can use this screen to set which PC should receive an incoming connection, as described below.

Conferencing & Telephony	
Select an Application	This lists applications that may generate incoming connections, where the destination (on your local LAN) is unknown.
Send incoming calls to	<p>This lists the PCs on your LAN.</p> <ul style="list-style-type: none"> • For each application listed above, you can choose a destination PC. • If necessary, you can add PCs manually, using the <i>Network Clients</i> option on the advanced menu. • There is no need to "Save" after each change; you can set the destination PC for each application, then click "Save".

Special Applications

If you use Internet applications that use non-standard connections or port numbers, you may find that they do not function correctly because they are blocked by the SpeedStream Powerline Wireless Router's firewall. In this case, you can define the application as a "Special Application".

Special Applications Screen

This screen can be reached by clicking the *Special Applications* button on the *Internet* screen.

You can then define your Special Applications. You will need detailed information about the application; this is normally available from the supplier of the application.

Also, note that the terms "Incoming" and "Outgoing" on this screen refer to traffic from the client (PC) viewpoint

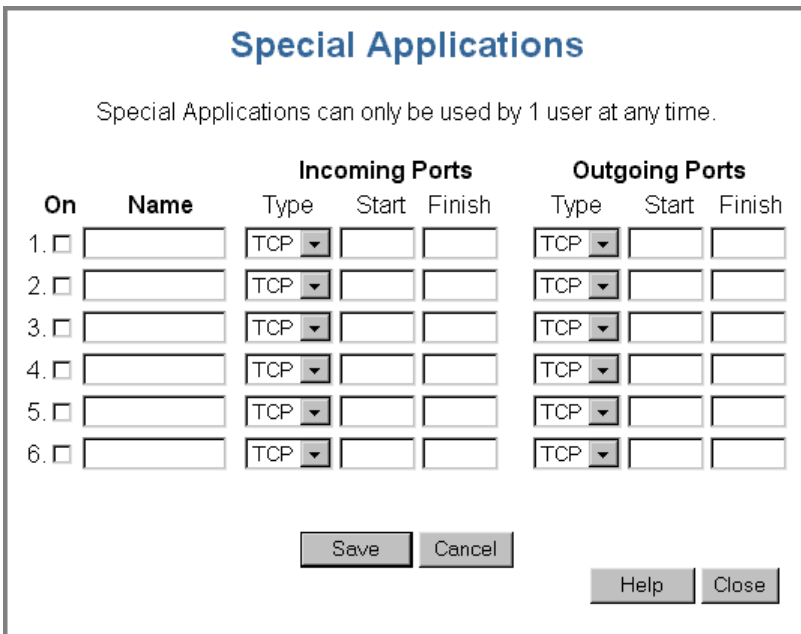

Figure 29: Special Applications Screen

Data - Special Applications Screen

Checkbox	Use this to Enable or Disable this Special Application as required.
Name	Enter a descriptive name to identify this Special Application.
Incoming Ports	<ul style="list-style-type: none"> • Type - Select the protocol (TCP or UDP) used when you receive data from the special application or service. (Note: Some applications use different protocols for outgoing and incoming data). • Start - Enter the beginning of the range of port numbers used by the application server, for data you receive. If the application uses a single port number, enter it in both the "Start" and "Finish" fields. • Finish - Enter the end of the range of port numbers used by the application server, for data you receive.
Outgoing Ports	<ul style="list-style-type: none"> • Type - Select the protocol (TCP or UDP) used when you send data to the remote system or service. • Start - Enter the beginning of the range of port numbers used by the application server, for data you send to it. If the application uses a single port number, enter it in both the "Start" and "Finish" fields. • Finish - Enter the end of the range of port numbers used by the application server, for data you send to it. If the application uses a single port number, enter it in both the "Start" and "Finish" fields.

Using a Special Application

- Configure the *Special Applications* screen as required.
- On your PC, use the application normally. Remember that only one (1) PC can use each Special application at any time. Also, when 1 PC is finished using a particular Special Application, there may need to be a "Time-out" before another PC can use the same Special Application. The "Time-out" period may be up to 3 minutes.



Note!

If an application still cannot function correctly, try using the "DMZ" feature.

DMZ

This feature, if enabled, allows one (1) computer on your LAN to be exposed to all users on the Internet, allowing unrestricted 2-way communication between the "DMZ PC" and other Internet users or Servers.

- This allows almost any application to be used on the "DMZ PC".
- The "DMZ PC" will receive all "Unknown" connections and data.
- If the DMZ feature is enabled, you must select the PC to be used as the "DMZ PC".
- The DMZ feature can be Enabled and Disabled on the *Advanced Internet* screen.



The "DMZ PC" is effectively outside the Firewall, making it more vulnerable to attacks. For this reason, you should only enable the DMZ feature when required.

URL Filter

The URL Filter allows you to block access to undesirable Web sites.

- To use this feature, you must define "filter strings". If the "filter string" appears in a requested URL, the request is blocked.
- Enabling the *URL Filter* also affects the *Internet Access Log*. If Enabled, the "Destination" field in the log will display the URL. Otherwise, it will display the IP Address.
- The *URL Filter* can be Enabled or Disabled on the *Advanced Internet* screen.

URL Filter Screen

Click the "Configure URL Filter" button on the *Internet* screen to access the *URL Filter* screen. An example screen is shown below.

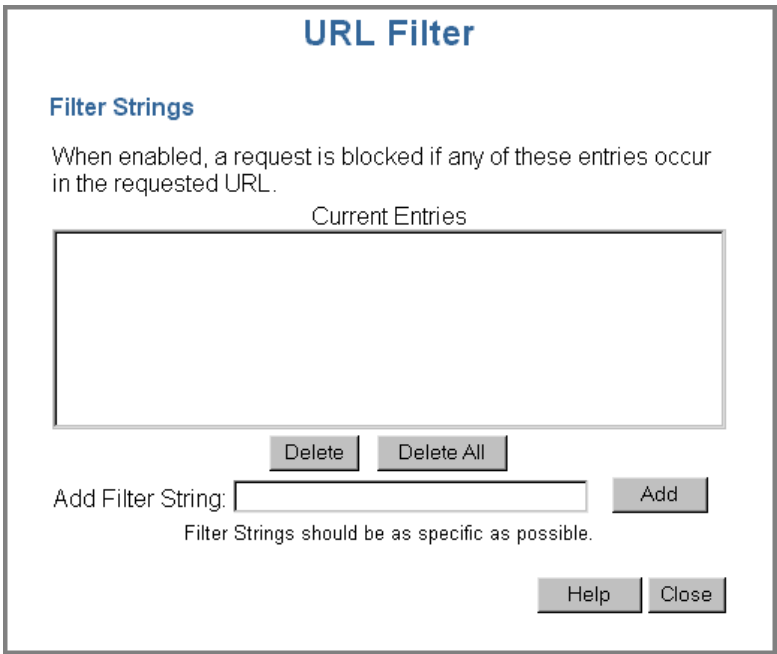

Figure 30: URL Filter Screen

Data - URL Filter Screen

Filter Strings	
Current Entries	This lists any existing entries. If you have not entered any values, this list will be empty.

Add Filter String

To add an entry to the list, enter it here, and click the "Add" button. An entry may be a Domain name (e.g. www.trash.com) or simply a string. (e.g. ads/) Any URL which contains ANY entry ANYWHERE in the URL will be blocked.

Buttons**Delete/Delete All**

Use these buttons to delete the selected entry or all entries, as required. Multiple entries can be selected by holding down the CTRL key while selecting.(On the Macintosh, hold the SHIFT key while selecting.)

Add

Use this to add the current Filter String to the site list.

Virtual Servers

This feature allows you to make Servers on your LAN accessible to Internet users. Normally, Internet users would not be able to access a server on your LAN because:

- Your Server does not have a valid external IP Address.
- Attempts to connect to devices on your LAN are blocked by the firewall in this device.

The "Virtual Server" feature solves these problems and allows Internet users to connect to your servers, as illustrated below.

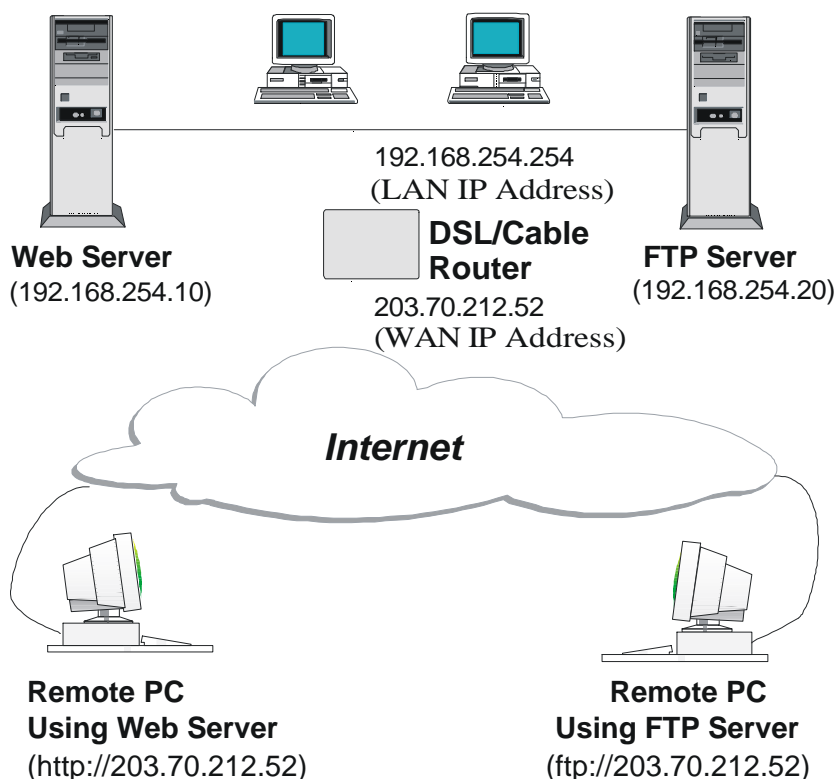

Figure 31: Virtual Servers

IP Address seen by Internet Users

Note that, in this illustration, both Internet users are connecting to the same IP Address, but using different protocols.

To Internet users, all virtual Servers on your LAN have the same IP Address. Your ISP allocates this IP Address.

This address should be static, rather than dynamic, to make it easier for Internet users to connect to your Servers.

However, you can use the *DDNS (Dynamic DNS)* feature to allow users to connect to your Virtual Servers using a URL, instead of an IP Address.

Virtual Servers Screen

The *Virtual Servers* screen is reached by the *Virtual Servers* link on the *Advanced* screen. An example screen is shown below.

Figure 32: Virtual Servers Screen

This screen lists a number of pre-defined Servers, and allows you to define your own Servers. Details of the selected Server are shown in the "Properties" area.

Data - Virtual Servers Screen

Servers	
Servers	This lists a number of pre-defined Servers, plus any Servers you have defined. Details of the selected Server are shown in the "Properties" area.
Properties	
Enable	Use this to Enable or Disable support for this Server, as required. <ul style="list-style-type: none"> • If Enabled, any incoming connections will be forwarded to the selected PC. • If Disabled, any incoming connection attempts will be blocked.
PC (Server)	Select the PC for this Server. The PC must be running the appropriate Server software.
Protocol	Select the protocol (TCP or UDP) used by the Server.
Internal Port No.	Enter the port number that the Server software is configured to use.

External Port No.	The port number used by Internet users when connecting to the Server. This is normally the same as the Internal Port Number. If it is different, this device will perform a "mapping" or "translation" function, allowing the server to use one port address, while clients use a different port address.
Buttons	
Defaults	This will delete any Servers you have defined, and set the pre-defined Servers to use their default port numbers.
Disable All	This will cause the "Enable" setting of all Virtual Servers to be set OFF.
Add	Add a new entry to the Virtual Server list, using the data shown in the "Properties" area on screen. The entry selected in the list is ignored, and has no effect.
Update	Update the current Virtual Server entry, using the data shown in the "Properties" area on screen.
Delete	Delete the current Virtual Server entry. Note that the pre-defined Servers cannot be deleted. Only Servers you have defined yourself can be deleted.
Clear Form	Clear all data from the "Properties" area, ready for input of a new Virtual Server entry.
Show All	List all entries in the Virtual Server database. The list will be in new window, allowing saving or printing of this data.

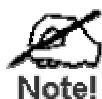
**Note!**

For each entry, the PC must be running the appropriate Server software.

Defining your own Virtual Servers

If the type of Server you wish to use is not listed on the *Virtual Servers* screen, you can define and manage your own Servers:

Create a new Server:

1. Click "Clear Form"
2. Enter the required data, as described above.
3. Click "Add".
4. The new Server will now appear in the list.

Modify (Edit) a Server:

1. Select the desired Server from the list
2. Make any desired changes (for example, change the Enable/Disable setting).
3. Click "Update" to save changes to the selected Server.

Delete a Server:

1. Select the entry from the list.
2. Click "Delete".

Note: You can only delete Servers you have defined. Pre-

defined Server cannot be deleted.

View all Settings of all Servers

Click the "Show All" button. This will generate a report in a new window, where it can be printed or saved, as well as viewed.



Note!

From the Internet, ALL Virtual Servers have the IP Address allocated by your ISP.

Connecting to the Virtual Servers

Once configured, anyone on the Internet can connect to your Virtual Servers. They must use the Internet IP Address (the IP Address allocated to you by your ISP).

e.g.

`http://203.70.212.52`

`ftp://203.70.212.52`

It is more convenient if you are using a Fixed IP Address from your ISP, rather than Dynamic. However, you can use the *Dynamic DNS* feature, described in the following section, to allow users to connect to your Virtual Servers using a URL, rather than an IP Address.

Dynamic DNS

This free service is very useful when combined with the *Virtual Server* feature. It allows Internet users to connect to your Virtual Servers using a URL, rather than an IP Address.

This also solves the problem of having a dynamic IP address. With a dynamic IP address, your IP address may change whenever you connect, which makes it difficult to connect to you.

The Service works as follows:

1. You must register for the service at <http://www.dyndns.org> (Registration is free). Your password will be E-mailed to you.
2. After registration, use the "Create New Host" option (at www.dyndns.org) to request your desired Domain name.
3. Enter your data from www.dyndns.org in the SpeedStream Powerline Wireless Router's DDNS screen.
4. The SpeedStream Powerline Wireless Router will then automatically ensure that your current IP Address is recorded at <http://www.dyndns.org>
5. From the Internet, users will be able to connect to your Virtual Servers (or DMZ PC) using your Domain name, as shown on this screen.

Dynamic DNS Screen

Select *Advanced* on the main menu, then *Dynamic DNS*, to see a screen like the following:

DDNS (Dynamic DNS)

DDNS Service Dynamic DNS allows you to provide Internet users with a domain name (instead of an IP Address) to access your Virtual Servers.

Register for this FREE service at <http://www.dyndns.org>

DDNS Data User name is set when you register; your password is E-mailed to you.

User Name:

Password:

Domain Name: .dyndns.org
(Allocated to you by www.dyndns.org)

DDNS Status:

Figure 33: DDNS Screen

Data - Dynamic DNS Screen

DDNS Service	
DDNS Service	<ul style="list-style-type: none"> You must sign up first to create a new account before using the service. The service is free. Click this link to connect to the www.dyndns.org Web site. Your initial password will be E-mailed to you; you can change this later if you wish. After registration, use the "Create New Host" link (on the www.dyndns.org Web site) to request a domain name.
DDNS Data	
User Name	Enter the "User name" specified at the www.dyndns.org Web site when you registered.
Password	Enter your current password for www.dyndns.org
Domain	<ul style="list-style-type: none"> Enter your domain name, as allocated at www.dyndns.org. The name should consist only of letters and the hyphen (dash). Using any other characters may cause problems.
DDNS Status	<p>This message is returned by the DDNS Server at www.dyndns.org</p> <ul style="list-style-type: none"> Normally, this message should be "Update successful" (current IP address was updated on the www.dyndns.org server). If the message is "No host", this indicates the host name entered was not allocated to you. You need to connect to

	www.dyndns.org and correct this problem.
--	--

Remote Management

This feature allows you to manage the SpeedStream Powerline Wireless Router via the Internet. An example screen is shown below.

Figure 34: Remote Management Screen

Data - Remote Management Screen

Remote Management	
Enable Remote Management	Enable to allow management via the Internet. If Disabled, this device will ignore management connection attempts from the Internet.
Port Number	Enter a port number between 1024 and 65535 (8080 is recommended). This port number must be specified when you connect (see below). Note: The default port number for HTTP (Web) connections is port 80, but using port 80 here will prevent the use of a Web "Virtual Server" on your LAN. (See <i>Advanced Internet - Virtual Servers</i>)
Current IP Address	You must use this IP Address to connect (see below). Your ISP allocates this IP Address. But if using a Dynamic IP Address, this value can change each time you connect to your ISP. So it is better if your ISP allocates you a Fixed IP Address.

To connect from a remote PC via the Internet

1. Ensure your Internet connection is established, and start your Web Browser.
2. In the "Address" bar, enter "HTTP://" followed by the Internet IP Address of the SpeedStream Powerline Wireless Router. If the port number is not 80, the port number is also required. (After the IP Address, enter ":" followed by the port number.)

e.g.

HTTP://123.123.123.123:8080

This example assumes the WAN IP Address is 123.123.123.123, and the port number is 8080.

Access Control

This feature is accessed by the *Access Control* link on the *Advanced* menu.

Overview

The Access Control feature allows administrators to restrict Internet Access by individual PCs. With the default settings, everyone has unrestricted Internet access.

To use this feature:

1. Set the desired restrictions on the "Default" group. All PCs are in the "Default" group unless explicitly moved to another group.
2. Set the desired restrictions on the other groups ("Group 1", "Group 2", "Group 3" and "Group 4") as needed.
3. Assign PCs to the groups as required.



Note!

Restrictions are imposed by blocking "Services", or types of connections. All common Services are pre-defined. If required, you can also define your own Services.

Access Control Log

To check the operation of the Access Control feature, an *Access Control Log* is provided. Click the *View Log* button on the *Access Control* screen to view this log.

This log shows attempted Internet accesses that have been **blocked** by the *Access Control* function.

Data shown in this log is as follows:

Date/Time	Date and Time of the attempted access.
Name	If known, the name of the PC whose access was blocked. This name is taken from the <i>Network Clients</i> database
Source IP address	The IP Address of the PC or device whose access request was blocked
MAC address	The hardware or physical address of the PC or device whose access request was blocked
Destination	The destination URL or IP address

Access Control Screen

To view this screen, select the *Access Control* link on the *Advanced* menu.

Figure 35: Access Control Screen

Data - Access Control Screen

Group	
Select Group	Select the desired Group. The screen will update to display the settings for the selected Group. Groups are named "Default", "Group 1", "Group 2", "Group 3" and "Group 4", and cannot be re-named.
"Members" Button	Click this button to add or remove members from the current Group. If the current group is "Default", then members cannot be added or deleted. This group contains PCs not allocated to any other group. See the following section for details of the <i>Group Members</i> screen.
Access Rights	
Internet Access	Select the desired options for the current group, as detailed below.
No Restriction	Nothing is blocked. Use this to create the least restrictive group.
Block All Access	All traffic via the WAN port is blocked. Use this to create the most restrictive group.

Use List Below - block Selected Services	You can select which Services are allowed, and which are blocked. Use this to gain fine control over a group.
Services	
Defined Services	Select the applications you wish to block. Multiple Services can be selected by holding the CTRL key (on the Macintosh, the SHIFT key) while selecting. Selected Services are blocked.
"Services" button	Click this to open the <i>Services</i> window, allowing you to define your own Services. See the following section for details of the <i>Services</i> screen.
Buttons	
Members	Click this button to add or remove members from the current Group. If the current group is "Default", then members cannot be added or deleted. This group contains PCs not allocated to any other group. See the following section for details of the <i>Group Members</i> screen.
Service	Click this button to add or remove services from the current list.
Save	Save the data on screen.
Cancel	Reverse any changes made since the last "Save".
View Log	See all the details in the Log.
Clear Log	Delete all data currently in the Log. This will make it easier to read new entries.

Group Members Screen

This screen is displayed when the *Members* button on the *Access Control* screen is clicked.

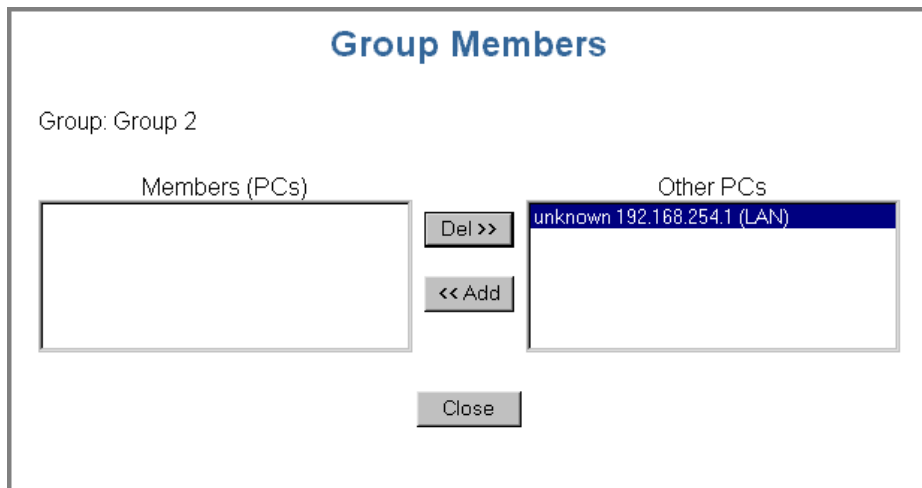

Figure 36: Group Members

Use this screen to add or remove members (PCs) from the current group.

- The "Del >>" button will remove the selected PC (in the *Members* list) from the current group.
- The "<< Add" button will add the selected PC (in the *Other PCs* list) to the current group.



PCs not assigned to any group will be in the "Default" group.
PCs deleted from any other Group will be added to the "Default" group.

Services Screen

This screen is displayed when the *Services* button on the *Access Control* screen is clicked.

The screenshot shows a window titled "Services". At the top, there is a section "Available Services" containing a list box with the following items: AIM(TCP:5190), BGP(TCP:179), BOOTP_CLIENT(UDP:68), BOOTP_SERVER(UDP:67..68), CU-SEEME(TCP/UDP:7648), and DNS(TCP/UDP:53). Below the list box is a "Delete" button. Underneath is a section "Add New Service" with a form containing the following fields: "Name:" with a text input field; "Type:" with a dropdown menu set to "TCP"; "Start Port:" with a text input field and "(TCP or UDP)" to its right; "Finish Port:" with a text input field and "(TCP or UDP)" to its right; and "ICMP Type:" with a text input field containing "n/a" and "(0..255)" to its right. At the bottom of the form are "Add" and "Cancel" buttons. At the bottom right of the window are "Help" and "Close" buttons.

Figure 37: Services

Data - Services Screen

Available Services	
Available Services	This lists all the available services.
"Delete" button	Use this to delete any Service you have added. Pre-defined Services can not be deleted.
Add New Service	
Name	Enter a descriptive name to identify this service.
Type	Select the protocol (TCP, UDP, ICMP) used to the remote system or service.
Start Port	For TCP and UDP Services, enter the beginning of the range of port numbers used by the service. If the service uses a single port number, enter it in both the "Start" and "Finish" fields.
Finish Port	For TCP and UDP Services, enter the end of the range of port numbers used by the service. If the service uses a single port number, enter it in both the "Start" and "Finish" fields.
ICMP Type	For ICMP Services, enter the type number of the required service.
Buttons	
Delete	Delete the selected service from the list.

Add	Add a new entry to the Service list, using the data shown in the "Add New Service" area on screen.
Cancel	Clear the " Add New Service " area, ready for entering data for a new Service.

Firmware Upgrade

The firmware (software) in the SpeedStream Powerline Wireless Router can be upgraded using your Web Browser.

You must first download the upgrade file, and then select *Upgrade* on the Advanced menu. You will see a screen like the following.

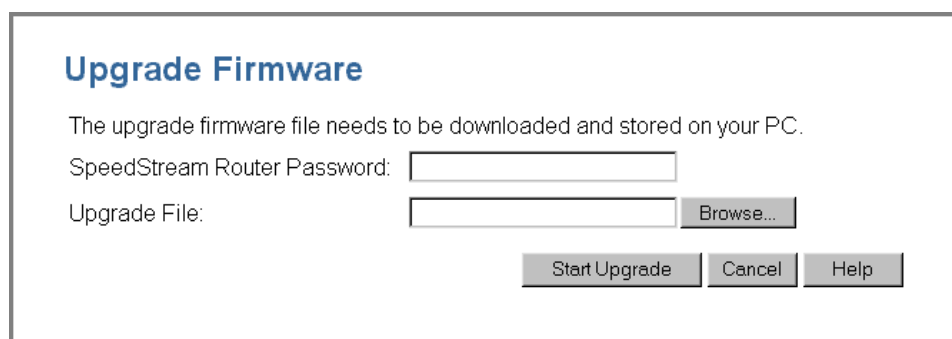

The screenshot shows a web interface titled "Upgrade Firmware". Below the title, there is a text instruction: "The upgrade firmware file needs to be downloaded and stored on your PC." Below this, there are two input fields. The first is labeled "SpeedStream Router Password:" and is empty. The second is labeled "Upgrade File:" and is also empty, with a "Browse..." button to its right. At the bottom of the form, there are three buttons: "Start Upgrade", "Cancel", and "Help".

Figure 38: Upgrade Firmware

To perform the Firmware Upgrade:

1. Click the "Browse" button and navigate to the location of the upgrade file.
2. Select the upgrade file. Its name will appear in the *Upgrade File* field.
3. Click the "Start Upgrade" button to commence the firmware upgrade.



Note!

The SpeedStream Powerline Wireless Router is unavailable during the upgrade process, and must restart when the upgrade is completed. Any connections to or through the SpeedStream Powerline Wireless Router will be lost.

Chapter 7

Advanced Configuration



This Chapter explains the settings available via the Advanced configuration section of the "Advanced" menu.

Overview

Normally, it is not necessary to use these screens, or change any settings. These screens and settings are provided to deal with non-standard situations, or to provide additional options for advanced users.

The settings available are:

Network Clients	This is the list of PCs shown when you select the "DMZ PC" or a "Virtual Server". This database is maintained automatically, but you can add and delete entries for PCs which use a Fixed (Static) IP Address.
Options	Various options, including DNS and UPnP.
Printer	Configure Logical Printers for use under Unix
MAC Address	Set the MAC (hardware) address used on the Internet (WAN port) interface. This is required only if your ISP has recorded the MAC (hardware) address you should use.
Routing	Only required if your LAN has other Routers or Gateways.
Security	Firewall settings.

Note: The screens shown below are identical for all SpeedStream SpeedStream Powerline Wireless Routers; therefore, some screenshots are shared between multiple user manuals.

Network Clients Screen

The *Network Clients* database is used whenever you need to select a PC (e.g. for the "DMZ" PC). It eliminates the need to enter IP addresses. An example *Network Clients* screen is shown below.

Network Clients

DHCP Clients are automatically added and updated.
If not listed, try restarting the PC.
PCs using a Fixed IP address can be added and deleted below.

Known PCs	
unknown	192.168.254.1 (LAN) (DHCP)

< Add

Name:

IP Address: . . .

Delete

Refresh Generate Report

Help

Figure 39: Network Clients Screen

- PCs that are "DHCP Clients" are automatically added to the database, and updated as required.
- By default, non-Server versions of Windows act as "DHCP Clients"; this setting is called "Obtain an IP Address automatically".
- The SpeedStream Powerline Wireless Router uses the "Hardware Address" to identify each PC, not the name or IP address. The "Hardware Address" can only change if you change the PC's network card or adapter.
- This system means you do NOT need to use Fixed (static) IP addresses on your LAN. However, you can add PCs using Fixed (static) IP Addresses to the *Network Clients* database if required.

Data - Network Clients Screen

Network Clients	
Known PCs	This lists all current entries. Data displayed is <i>name (IP Address) type</i> . For this model, the "type" will either be "LAN" or "WLAN" (Wireless LAN).
Name	If adding a new PC to the list, enter its name here. It is best if this matches the PC's "hostname".
IP Address	Enter the IP Address of the PC. The PC will be sent a "ping" to determine its hardware address. If the PC is not available (not connected, or not powered On) you will not be able to add it.

Buttons	
Add	This will add the new PC to the list. The PC will be sent a "ping" to determine its hardware address. If the PC is not available (not connected, or not powered On) you will not be able to add it.
Delete	Delete the selected PC from the list. This should be done in 2 situations: <ul style="list-style-type: none">• The PC has been removed from your LAN.• The entry is incorrect.
Refresh	Update the data on screen.
Generate Report	Display a read-only list showing full details of all entries in the <i>Network Clients</i> database.

Options

This screen allows advanced users to enter or change a number of settings. For normal operation, there is no need to use this screen or change any settings. An example Options screen is shown below.

Options

Backup DNS

Backup DNS (1) IP Address:

Backup DNS (2) IP Address:

These DNS (Domain Name Servers) are used only if the primary DNS is unavailable.

TFTP

Enable Firmware Upgrade using TFTP

UPnP

Enable UPnP Services

Allow configuration changes through UPnP

Allow Internet access to be disabled

Figure 40: Options Screen

Data - Options Screen

Backup DNS	
IP Address	Enter the IP Address of the DNS (Domain Name Servers) here. These DNS will be used only if the primary DNS is unavailable.
TFTP	
Enable Firmware Upgrade using TFTP	<ul style="list-style-type: none"> If enabled, TFTP (Trivial FTP) can be used to upgrade the firmware in this device. This is normally not required; a Windows utility is available for this purpose. You must obtain the firmware upgrade file first; instructions for using TFTP will be available with the upgrade.
UPnP	
Enable UPnP Services	<ul style="list-style-type: none"> UPnP (Universal Plug and Play) allows automatic discovery and configuration of equipment attached to your LAN. UPnP is by supported by Windows ME, XP, or later. If Enabled, this device will be visible via UPnP. If Disabled, this device will not be visible via UPnP.
Allow Configuration...	<ul style="list-style-type: none"> If checked, then UPnP users can change the configuration. If Disabled, UPnP users can only view the configuration.

**Allow Internet
access to be
disabled**

- If checked, then UPnP users can disable Internet access via this device.
 - If Disabled, UPnP users can NOT disable Internet access via this device.
-

MAC Address

The MAC (hardware) address is a low-level network identifier. It may be called "MAC Address", "Hardware Address", or "Physical Address". On a PC, this address is associated with the Network card or adapter. The address on the *MAC Address* screen is the address on the Internet (WAN port) interface, and has no effect on the LAN interface.

- If your ISP asks for the "Network Adapter Address", "Physical Address", "Hardware Address", or "MAC Address" for the PC the DSL/Cable modem is connected to, provide this value.
- If your ISP has already recorded a MAC address, you can change the address used by the SpeedStream Powerline Wireless Router to match the address recorded by your ISP.

MAC Address Screen

Select *MAC Address* from the *Advanced* menu to reach a screen like the example below.

Figure 41: MAC address screen

Data - MAC address Screen

MAC (hardware) Address	The current MAC (hardware) address is displayed. If your ISP has recorded a Hardware Address, you can "spoof" that address by entering it in the address field. The hardware address consists of 12 characters, where each character is a digit (0..9) or a character between A and F.
Buttons	
Default	Inserts the default MAC address into the MAC address field. You must click "Save" to actually change the address used.
Clone MAC Address	Inserts the MAC address from your PC into the MAC address field. You must click "Save" to actually change the address used.
Save	Save your changes to the SpeedStream Powerline Wireless Router.
Cancel	Reverse any changes made since the last "Save".



If the MAC address is changed, the SpeedStream Powerline Wireless Router must be

restarted.

Routing

Overview

- If you don't have other Routers or Gateways on your LAN, you can ignore the "Routing" page completely.
- If the SpeedStream Powerline Wireless Router is only acting as a Gateway for the local LAN segment, ignore the "Routing" page even if your LAN has other Routers.
- If your LAN has a standard Router (e.g. Cisco) on your LAN, and the SpeedStream Powerline Wireless Router is to act as a Gateway for all LAN segments, enable RIP (Routing Information Protocol) and ignore the Static Routing table.
- If your LAN has other Gateways and Routers, and you wish to control which LAN segments use each Gateway, do NOT enable RIP (Routing Information Protocol). Configure the Static Routing table instead. (You also need to configure the other Routers.)
- If using Windows 2000 Data center Server as a software Router, enable RIP on the SpeedStream Powerline Wireless Router, and ensure the following Windows 2000 settings are correct:
 - Open *Routing and Remote Access*
 - In the console tree, select *Routing and Remote Access, [server name], IP Routing, RIP*
 - In the "Details" pane, right-click the interface you want to configure for RIP version 2, and then click "Properties".
 - On the "General" tab, set *Outgoing packet protocol* to "RIP version 2 broadcast", and *Incoming packet protocol* to "RIP version 1 and 2".

Routing Screen

The routing table is accessed by the *Routing* link on the *Advanced* screen.

Using this Screen

Generally, you will use either RIP (Routing Information Protocol) OR the Static Routing Table, as explained above, although it is possible to use both methods simultaneously.

Static Routing Table

- If RIP is not used, an entry in the routing table is required for each LAN segment on your Network, other than the segment to which this device is attached.
- The other Routers must also be configured. See *Configuring Other Routers on your LAN* later in this chapter for further details and an example.

Figure 42: Routing Screen

Data - Routing Screen

RIP	
Enable RIP	<p>Check this to enable the RIP (Routing Information Protocol) feature of the SpeedStream Powerline Wireless Router.</p> <p>The SpeedStream Powerline Wireless Router supports RIP 1 only.</p>
Static Routing	
Static Routing Table Entries	<p>This list shows all entries in the Routing Table.</p> <ul style="list-style-type: none"> The "Properties" area shows details of the selected item in the list. Change any the properties as required, then click the "Update" button to save the changes to the selected entry.
Properties	<ul style="list-style-type: none"> Destination Network - The network address of the remote LAN segment. For standard class "C" LANs, the network address is the first 3 fields of the Destination IP Address. The 4th (last) field can be left at 0. Network Mask - The Network Mask for the remote LAN segment. For class "C" networks, the default mask is 255.255.255.0 Gateway IP Address - The IP Address of the Gateway or Router that the SpeedStream Powerline Wireless Router must use to communicate with the destination above. (NOT the router attached to the remote segment.) Metric - The number of "hops" (routers) to pass through to reach the remote LAN segment. The shortest path will be used.

	The default value is 1.
Buttons	
Save	Save the RIP setting. This has no effect on the Static Routing Table.
Add	Add a new entry to the Static Routing table, using the data shown in the "Properties" area on screen. The entry selected in the list is ignored, and has no effect.
Update	Update the current Static Routing Table entry, using the data shown in the "Properties" area on screen.
Delete	Delete the current Static Routing Table entry.
Clear Form	Clear all data from the "Properties" area, ready for input of a new entry for the Static Routing table.
Generate Report	Generate a read-only list of all entries in the Static Routing table.

Configuring Other Routers on your LAN

It is essential that all IP packets for devices not on the local LAN be passed to the SpeedStream Powerline Wireless Router, so that they can be forwarded to the external LAN, WAN, or Internet. To achieve this, the local LAN must be configured to use the SpeedStream Powerline Wireless Router as the *Default Route* or *Default Gateway*.

Local Router

The local router is the Router installed on the same LAN segment as the SpeedStream Powerline Wireless Router. This router requires that the *Default Route* is the SpeedStream Powerline Wireless Router itself. Typically, routers have a special entry for the *Default Route*. It should be configured as follows.

Destination IP Address	Normally 0.0.0.0, but check your router documentation.
Network Mask	Normally 0.0.0.0, but check your router documentation.
Gateway IP Address	The IP Address of the SpeedStream Powerline Wireless Router.
Metric	1

Other Routers on the Local LAN

Other routers on the local LAN must use the SpeedStream Powerline Wireless Router's *Local Router* as the *Default Route*. The entries will be the same as the SpeedStream Powerline Wireless Router's local router, with the exception of the *Gateway IP Address*.

- For a router with a direct connection to the SpeedStream Powerline Wireless Router's local Router, the *Gateway IP Address* is the address of the SpeedStream Powerline Wireless Router's local router.
- For routers that must forward packets to another router before reaching the SpeedStream Powerline Wireless Router's local router, the *Gateway IP Address* is the address of the intermediate router.

Static Routing - Example

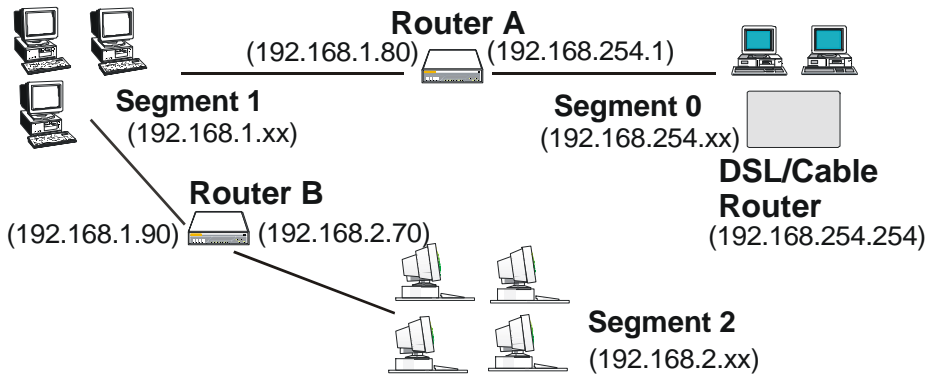

Figure 43: Routing Example

For the SpeedStream Powerline Wireless Router's Routing Table

For the LAN shown above, with 2 routers and 3 LAN segments, the SpeedStream Powerline Wireless Router requires 2 entries as follows.

Entry 1 (Segment 1)	
Destination IP Address	192.168.1.0
Network Mask	255.255.255.0 (Standard Class C)
Gateway IP Address	192.168.254.1 (SpeedStream Powerline Wireless Router's local Router)
Metric	1
Entry 2 (Segment 2)	
Destination IP Address	192.168.2.0
Network Mask	255.255.255.0 (Standard Class C)
Gateway IP Address	192.168.254.1 (SpeedStream Powerline Wireless Router's local Router)
Metric	2

For Router A's Default Route

Destination IP Address	0.0.0.0
Network Mask	0.0.0.0
Gateway IP Address	192.168.254.254 (SpeedStream Powerline Wireless Router's IP Address)

For Router B's Default Route

Destination IP Address	0.0.0.0
Network Mask	0.0.0.0
Gateway IP Address	192.168.254.254 (SpeedStream Powerline Wireless Router's local router)

Security

The security screen is accessed by the *Security* option on the *Advanced* menu.

Figure 44: Security Screen

Data - Security Screen

Firewall	
Enable DoS Firewall	<p>If enabled, DoS (Denial of Service) attacks will be detected and blocked. The default is enabled. It is strongly recommended that this setting be left enabled.</p> <p>Note:</p> <ul style="list-style-type: none"> • A DoS attack does not attempt to steal data or damage your PCs, but overloads your Internet connection so you cannot use it - the service is unavailable. • The SpeedStream Powerline Wireless Router uses "Stateful Inspection" technology. This system can detect situations where individual TCP/IP packets are valid, but collectively they become a DoS attack.
Threshold	<p>This setting affects the number of "half-open" connections allowed.</p> <ul style="list-style-type: none"> • A "half-open" connection arises when a remote client contacts the Server with a connection request, but then does not reply to the Server's response. • While the optimum number of "half-open" connections allowed (the "Threshold") depends on many factors, the most important factor is the available bandwidth of your Internet connection. • Select the setting to match the bandwidth of your Internet connection.

ICMP (Ping)**Respond to
ICMP (ping)**

The ICMP protocol is used by the "ping" and "traceroute" programs, and by network monitoring and diagnostic programs.

- If checked, the SpeedStream Powerline Wireless Router will respond to ICMP packets received from the Internet.
 - If not checked, ICMP packets from the Internet will be ignored. Disabling this option provides a slight increase in security.
-

Appendix A

Troubleshooting



This Appendix covers the most likely problems and their solutions.

Overview

This chapter covers some common problems that may be encountered while using the SpeedStream Powerline Wireless Router and some possible solutions to them. If you follow the suggested steps and the SpeedStream Powerline Wireless Router still does not function properly, contact your dealer for further advice.

General Problems

Problem 1: **Can't connect to the SpeedStream Powerline Wireless Router to configure it.**

Solution 1: Check the following:

- The SpeedStream Powerline Wireless Router is properly installed, LAN connections are OK, and it is powered ON. Check the LEDs for port status.
- Ensure that your PC and the SpeedStream Powerline Wireless Router are on the same network segment. (If you don't have a router, this must be the case.)
- If your PC is set to "Obtain an IP Address automatically" (DHCP client), restart it.
- If your PC uses a Fixed (Static) IP address, ensure that it is using an IP Address within the range 192.168.254.1 to 192.168.254.253 and thus compatible with the SpeedStream Powerline Wireless Router's default IP Address of 192.168.254.254.

Also, the Network Mask should be set to 255.255.255.0 to match the SpeedStream Powerline Wireless Router.

In Windows, you can check these settings by using *Control Panel-Network* to check the *Properties* for the TCP/IP protocol.

Internet Access

Problem 1: **When I enter a URL or IP address I get a time out error.**

Solution 1: A number of things could be causing this. Try the following troubleshooting steps.

- Check if other PCs work. If they do, ensure that your PCs IP settings are correct. If using a Fixed (Static) IP Address, check the Network Mask, Default gateway and DNS as well as the IP Address.
- If the PCs are configured correctly, but still not working, check the SpeedStream Powerline Wireless Router. Ensure that it is connected and ON. Connect to it and check its settings. (If you can't connect to it,

check the LAN and power connections.)

- If the SpeedStream Powerline Wireless Router is configured correctly, check your Internet connection (DSL/Cable modem etc) to see that it is working correctly.

Problem 2: **Some applications do not run properly when using the SpeedStream Powerline Wireless Router.**

Solution 2: The SpeedStream Powerline Wireless Router processes the data passing through it, so it is not transparent.

Use the *Special Applications* feature to allow the use of Internet applications that do not function correctly.

If this does solve the problem you can use the *DMZ* function. This should work with almost every application, but:

- It is a security risk, since the firewall is disabled for the *DMZ* PC.
- Only one (1) PC can use this feature.

Appendix B

Specifications



SpeedStream Powerline Wireless Router

Model	SS2524 SpeedStream Powerline Wireless Router
Dimensions	204mm(W) * 127mm(D) * 29mm(H)
Operating Temperature	0° C to 40° C
Storage Temperature	-10° C to 70° C
Network Protocol:	NAT, PPPoE, HTTP, DHCP client/server, TCP/IP
Network Interface:	5 Ethernet: 4 * 10/100BaseT (RJ45) auto-Switching Hub ports for LAN devices 1 * 10/100BaseT (RJ45) for WAN * Powerline Interface (via supplied power cord only) * 802.11b Wireless
LEDs	14
Power	110V AC

Wireless Interface

Standards	IEEE802.11b WLAN, PCMCIA 2.1, JEIDA 4.2
Frequency	2.4 to 2.4835GHz (Industrial Scientific Medical Band)
Channels	Maximum 14 Channels, depending on regulatory authorities
Data Rate	11 / 5.5 / 2 / 1 Mbps
Coverage Area	Closed Space: 25m @11Mbps, 100m @5.5Mbps or lower
Power	DC +3.3V / 220mA
Output Power	13dBm (typical)
Receiver Sensitivity	-80dBm Min.
Operating Temperature	0° to 55°C
Storage Temperature	-25° to 70°C
Relative humidity	10% to 90%

FCC Statement

This equipment has been tested and found to comply with the limits for a Class B digital device, pursuant to Part 15 of the FCC Rules. These limits are designed to provide reasonable protection against harmful interference in a residential installation.

This equipment generates, uses and can radiate radio frequency energy and, if not installed and used in accordance with the instructions, may cause harmful interference to radio communications. However, there is no guarantee that interference will not occur in a particular installation. If this equipment does cause harmful interference to radio or television reception, which can be determined by turning the equipment off and on, the user is encouraged to try to correct the interference by one of the following measures:

- Reorient or relocate the receiving antenna.
- Increase the separation between the equipment and receiver.
- Connect the equipment into an outlet on a circuit different from that to which the receiver is connected.
- Consult the dealer or an experienced radio/TV technician for help.

To assure continued compliance, any changes or modifications not expressly approved by the party responsible for compliance could void the user's authority to operate this equipment. (Example - use only shielded interface cables when connecting to computer or peripheral devices).

FCC Radiation Exposure Statement

This equipment complies with FCC RF radiation exposure limits set forth for an uncontrolled environment. This equipment should be installed and operated with a minimum distance of 20 centimeters between the radiator and your body.

This device complies with Part 15 of the FCC Rules. Operation is subject to the following two conditions:

- (1) This device may not cause harmful interference, and
- (2) this device must accept any interference received, including interference that may cause undesired operation.

This transmitter must not be co-located or operating in conjunction with any other antenna or transmitter.

Warning!

The case contains no user-serviceable components. Only qualified service staff should open the case.

Appendix C

Technical Support



Before contacting technical support, please refer to the previous Troubleshooting information. If you are still unable to resolve the problem, be prepared to provide the following information:

- Model number (SS2524)
- Date of purchase or installation
- Description of problem

SpeedStream Technical Support Services are available via the web, e-mail and telephone.

Visit our website at www.SpeedStream.com for the latest product information and support knowledge base.

Contact SpeedStream Support via e-mail at: Support@SpeedStream.com

Telephone Support for North America only: 877-823-6722