

L8151A Triple Aquastat® Relay

The L8151A is a remote bulb controller for use with hydronic heating systems that include domestic hot water service.



- Provides high limit, low limit, and circulator control for maintaining boiler temperatures.
- Can provide multizone control by using a separate thermostat and R845 Relay for each zone.
- An internal transformer powers the thermostat circuit.

- Shielded capillary allows convenient mounting.
- Consists of a diaphragm powerhead and micro switch assembly that responds to temperature changes in the boiler water.

CONTENTS

<i>Specifications</i>	2
<i>Ordering Information</i>	2
<i>Installation</i>	2
<i>Operation and Settings</i>	5
<i>Checkout</i>	6

Specification

IMPORTANT: *The specifications given in this publication do not include normal manufacturing tolerances. Therefore, this unit may not exactly match the listed specifications. Also, this product is tested and calibrated under closely controlled conditions, and some minor differences in performance can be expected if those conditions are changed.*

MODEL: L8151A Triple Aquastat® Relay for remote bulb control of hydronic heating systems that include domestic hot water.

ELECTRICAL RATINGS:

Power Supply: 120 Vac, 60 Hz; 220 Vac, 50 Hz and 240 Vac, 60 Hz operation.

Contact Ratings (A): See Table 1.

TABLE 1—CONTACT RATINGS.

	120 Vac	240 Vac
Full Load	7.4	3.7
Locked Rotor	44.4	22.2

MAXIMUM POWER CONSUMPTION: 8W at 120 Vac, 60 Hz.

MAXIMUM AMBIENT TEMPERATURE: 150°F (66°C) at case, 265°F (130°C) at sensing element.

PRESSURE RATING: 200 psi (1380 kPa) on outside of immersion well.

THERMOSTAT HEAT ANTICIPATOR SETTING: 0.2A. **LOW LIMIT (Fig. 2):**

Function: Maintains water temperature at setting during thermostat off periods.

Setting: 110°F to 220°F adjustable (43°C to 104°C).

Differential: 10°F to 25°F adjustable (6°C to 14°C).

HIGH LIMIT (Fig. 2):

Function: Opens burner circuit if water temperature reaches high limit setting.

Setting: 130°F to 240°F adjustable (54°C to 116°C).

Differential: 10°F fixed (6°C).

MOUNTING MEANS: Mounting lugs on back of case.

DIMENSIONS: See Fig. 1.

SENSING ELEMENT: 3/8 x 2-7/8 in. (10 x 73 mm).

CAPILLARY LENGTH: 36 in. (914 mm), armored capillary.

UNDERWRITERS LABORATORIES INC. LISTED: File No. MP466, Guide No. MBPR2.

Installation

WHEN INSTALLING THIS PRODUCT...

1. Read these instructions carefully. Failure to follow them could damage the product or cause a hazardous condition.

2. Check the ratings given in the instructions and on the product to make sure the product is suitable for your application.

3. Installer must be a trained, experienced service technician.

4. After installation is complete, check out product operation as provided in these instructions.



WARNING

CAN CAUSE PROPERTY DAMAGE, SEVERE INJURY OR DEATH.

Product is for use only in a system with a pressure relief valve.

Ordering Information

When purchasing replacement and modernization products from your TRADELINE® wholesaler or distributor, refer to the Tradeline® Catalog or price sheets for complete ordering number, or specify—

1. Order number.
2. Accessories, if desired.
3. Order additional system components and system accessories separately.

If you have additional questions, need further information, or would like to comment on our products or services, please write or phone:

1. Your local Home and Building Control Sales Office (please check the white pages of your phone directory).
2. Home and Building Control Customer Logistics
Honeywell Inc., 1885 Douglas Drive North
Minneapolis, Minnesota 55422-4386

In Canada—Honeywell Limited/Honeywell Limitée, 35 Dynamic Drive, Scarborough, Ontario M1V 4Z9. International Sales and Service Offices in all principal cities of the world. Manufacturing in Australia, Canada, Finland, France, Germany, Japan, Mexico, Netherlands, Spain, Taiwan, United Kingdom, U.S.A.

CAUTION

- Disconnect power supply before beginning installation to prevent electrical shock or equipment damage.
- Avoid making sharp bends or kinks in the capillary. Bends should be no less than 1 in. (25 mm).

IMPORTANT: *Terminals on these Aquastat® Relays are approved for copper wire only.*

Fig. 1—Approximate L8151 dimensions in in. (mm).

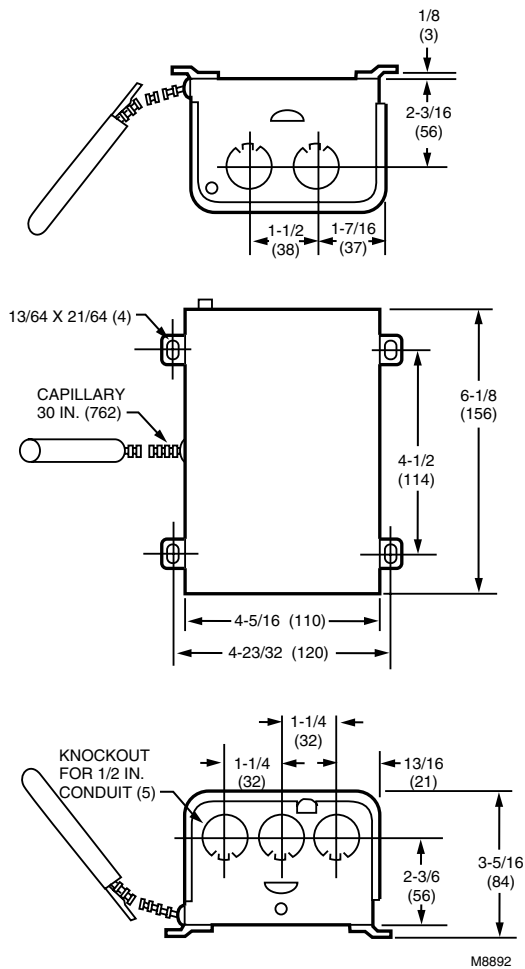

MOUNTING THE CASE

Mount the case in a convenient location near the boiler. Remember that the shielded capillary must reach from the case to the immersion well. This maximum ambient temperature of the selected location must not exceed 150°F (66°C) at the case, 265°F (130°C) at the sensing element.

IMMERSION WELL MOUNTING

NOTE: Immersion well must be ordered separately. For a list of available wells, refer to form 68-0040, Wells and Fittings for Temperature Controllers.

The boiler manufacturer generally provides a tapping for the immersion well. This tapping should be located at a point where typical water temperature can be measured. The immersion well must never be located close to a hot or cold water inlet or a steam coil, or where the pressure exceeds 200 psi (1380 kPa).

If the system is filled, drain to a point below the selected installation location.

Fig 2— Internal view of L8151.

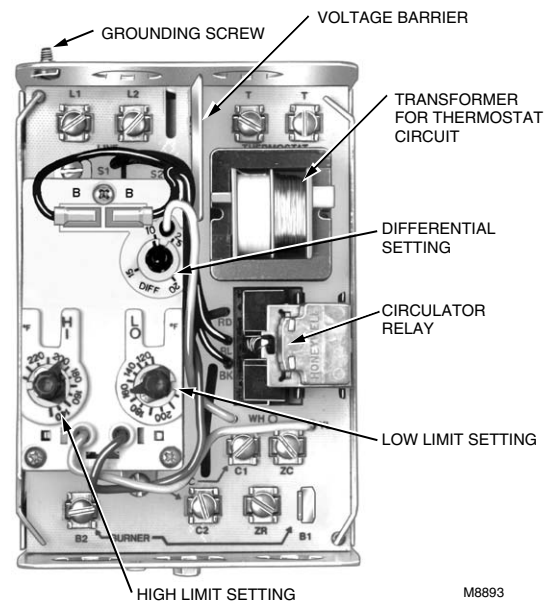

1. Screw the well into the boiler, tank, or pipe tapping.
2. Insert the bulb into the well, pushing tubing until bulb bottoms in well. Avoid making sharp bends or kinks in the capillary. Bends should be no sharper than 1 in. (25 mm) radius.
3. Attach the retainer clamp to end of well spud. Loosen draw nut and spread jaws of clamp with screwdriver if necessary, Fig. 3.

Fig. 3—Remote bulb installation.

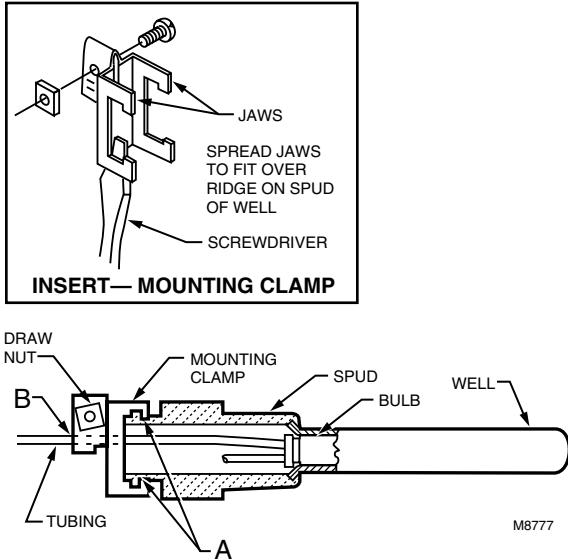

4. With part no.121371AA Retainer Clamp attached to well spud (be sure jaws of clamp hook over ridge at end of spud, as shown at points A), adjust tubing to fit through retainer clamp groove, as shown at point B.

5. Tighten draw nut so that retainer clamp is firmly attached to well spud and tubing is held securely in place. Be careful not to damage the capillary.

6. Carefully coil the excess capillary at the bottom of the Aquastat® case.

WIRING



CAUTION

- Disconnect power supply before wiring to avoid electrical shock or equipment damage.
- Be sure the terminal connections are inside an enclosure that meets local codes.

IMPORTANT: *Terminals on the L8151A Aquastat® Relay are approved for use only with copper wire. The terminals allow wraparound wiring only.*

1. Strip 7/16 in. of insulation from the wire end.
2. Wrap the wire at least three fourths of the distance around the screws as shown.
3. Use a standard flat-headed screwdriver to tighten the screw until the wire is snugly in contact with the screw and contact plate.
4. Tighten the screw an additional one-half turn.

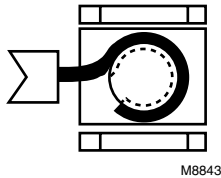

NOTE: Do not use a push-type ratchet screwdriver.

All wiring must comply with local electrical codes and ordinances. The limits given in the Specifications section must not be exceeded when applying this control. Use manufacturer instructions when wiring controlled equipment or refer to typical hookups in Fig. 4 through 6.

When the B1 terminal on the device being replaced is 1/4 in. tab terminal, use the existing wiring harness terminals to install the replacement device. When the B1 terminal on the device being replaced is a screw terminal, insert the provided tab terminal to screw terminal adapter on the 1/4 in. tab terminal of the replacement device. After the adapter is installed, the existing wraparound wire end can be reused to make an electrical connection to the B1 terminal.

NOTE: Do not use a push type ratchet screwdriver.

1. Strip 7/16 in. of insulation from the wire end.
2. Wrap the wire at least three-fourths of the distance around the screw as shown.
3. Using a standard, flat-headed screwdriver, tighten the screw until the wire is snugly in contact with the screw and contact plate.
4. Tighten the screw an additional one-half turn.

Fig. 4—Typical hookup for L8151A in a single zone system.

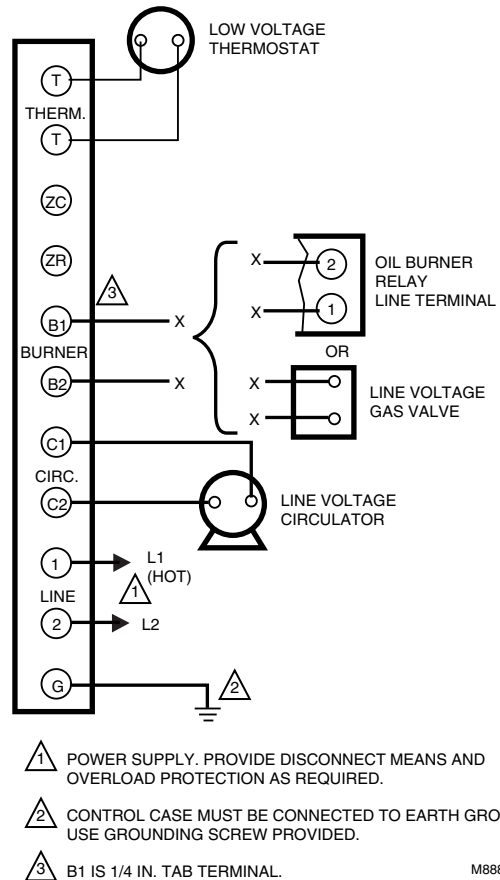

Operation and Settings

HIGH LIMIT

The high limit opens and turns off the burner when the water temperature reaches the setpoint. The high limit automatically resets after the water temperature drops past the setpoint and through the 10°F (6°C) differential.



WARNING

**CAN CAUSE PROPERTY DAMAGE,
SEVERE INJURY OR DEATH.**

Product is for use only in a system with a pressure relief valve.

LOW LIMIT AND CIRCULATOR CONTROL

On a temperature rise, with the adjustable differential at the minimum setting of 10°F (6°C), the low limit circuit (RB) breaks and the circulator circuit (R-W) makes at the control setpoint. On a temperature drop of 10°F (6°C) below the setpoint, the R-B circuit makes and the R-W circuit breaks.

Fig. 5—Typical hookup for the L8151A in a multizone system.

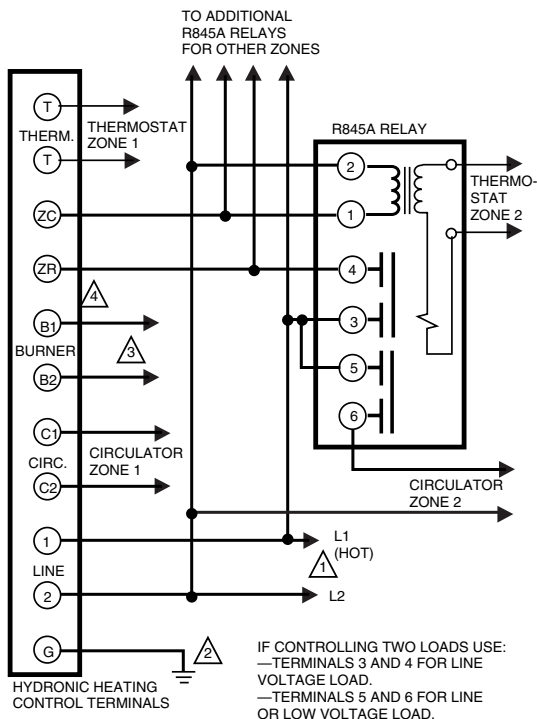

- ⚠️ POWER SUPPLY. PROVIDE DISCONNECT MEANS AND OVERLOAD PROTECTION AS REQUIRED.
- ⚠️ CONTROL CASE MUST BE CONNECTED TO EARTH GROUND. USE GROUNDING SCREW PROVIDED.
- ⚠️ LINE VOLTAGE OIL BURNER CONTROL OR GAS VALVE.
- ⚠️ B1 IS 1/4 IN. TAB TERMINAL.

M8885

Fig. 6—L8151A internal schematic.

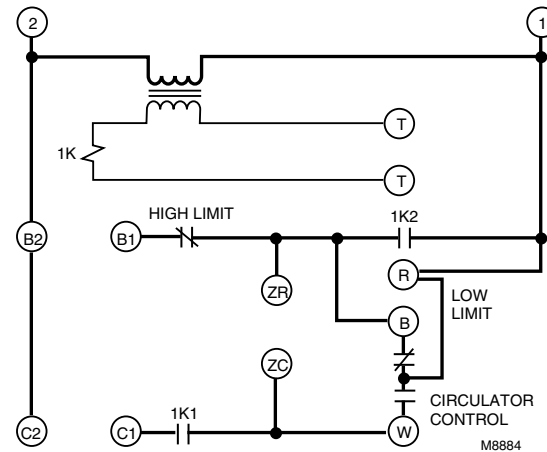
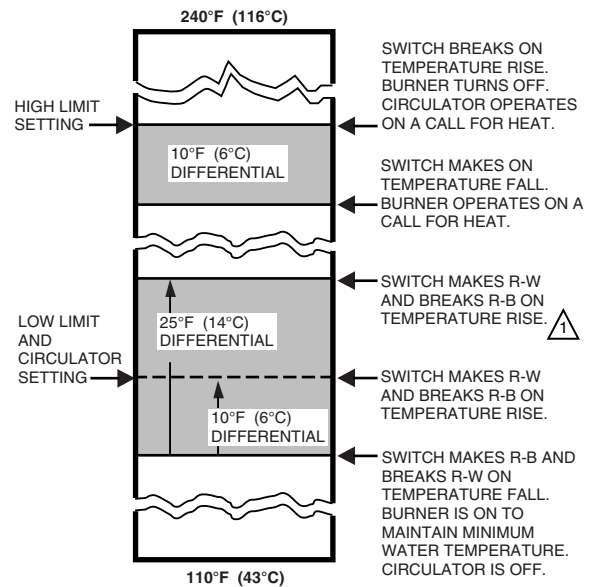

Fig. 7—Relationship of setpoints and differential.



- ⚠️ WHEN WATER REACHES PROPER TEMPERATURE, THE BURNER SHUTS OFF OR THE CIRCULATOR PUMP STARTS (WHEN CALLING FOR HEAT).

M1523

At any differential setting greater than 10°F (6°C), the R-B make and R-W break temperatures remain the same (control setting minus 10°F (6°C)). The R-B break and R-W make temperatures are the setpoint temperatures plus the difference between the differential setting and 10°F (6°C).

EXAMPLE: Setpoint of 140°F (60°C) differential set at 25°F (14°C). On a temperature rise, R-B breaks and R-W makes at 155°F (68°C). On a temperature fall, R-B makes and R-W breaks at 130°F (54°C); see Fig. 7.

THERMOSTAT ANTICIPATOR

Set the thermostat heat anticipator at 0.2A.

Checkout

Put the system into operation and observe each function through at least one complete cycle. Be sure the control operates as intended.

Honeywell

Automation and Control Solutions

Honeywell International Inc.
1985 Douglas Drive North
Golden Valley, MN 55422

Honeywell Limited-Honeywell Limitée
35 Dynamic Drive
Scarborough, Ontario M1V 4Z9



Printed in U.S.A. on recycled paper containing at least 10% post-consumer paper fibers.