

SmartNode 5200 Enterprise Session Border Router

Getting Started Guide



Important

This is a Class A device and is intended for use in a light industrial (commercial) environment only. It is not intended nor approved for use in a heavy industrial or residential environment.

This device is approved for connection to the public ISDN telecommunication network, over BRI/S0-ISDN interfaces.

Sales Office: +1 (301) 975-1000
Technical Support: +1 (301) 975-1007
E-mail: support@patton.com
WWW: www.patton.com

Patton Electronics Company, Inc.

7622 Rickenbacker Drive
Gaithersburg, MD 20879 USA
Tel: +1 (301) 975-1000
Fax: +1 (301) 869-9293
Support: +1 (301) 975-1007
Web: www.patton.com
E-mail: support@patton.com

Trademark Statement

The terms *SmartNode*, *SmartWare* and *SmartView* are trademarks of Patton Electronics Company. All other trademarks presented in this document are the property of their respective owners.

Copyright © 2010, Patton Electronics Company. All rights reserved.

The information in this document is subject to change without notice. Patton Electronics assumes no liability for errors that may appear in this document.

Warranty Information

The software described in this document is furnished under a license and may be used or copied only in accordance with the terms of such license. For information about the license, see [Appendix F, "End user license agreement"](#) on page 48 or go to www.patton.com.

Patton Electronics warrants all SmartNode router components to be free from defects, and will—at our option—repair or replace the product should it fail within one year from the first date of the shipment.

This warranty is limited to defects in workmanship or materials, and does not cover customer damage, abuse or unauthorized modification. If the product fails to perform as warranted, your sole recourse shall be repair or replacement as described above. Under no condition shall Patton Electronics be liable for any damages incurred by the use of this product. These damages include, but are not limited to, the following: lost profits, lost savings and incidental or consequential damages arising from the use of or inability to use this product. Patton Electronics specifically disclaims all other warranties, expressed or implied, and the installation or use of this product shall be deemed an acceptance of these terms by the user.

Summary Table of Contents

- 1 General information 14
- 2 Applications overview..... 18
- 3 SmartNode installation..... 20
- 4 Initial configuration 25
- 5 Contacting Patton for assistance 31
- A Compliance information 34
- B Specifications 36
- C Cabling 39
- D Port pin-outs 41
- E SmartNode 5200 factory configuration 43
- F End user license agreement 48

Table of Contents

Summary Table of Contents	3
Table of Contents	4
List of Figures	7
List of Tables	8
About this guide	9
Audience.....	9
Structure.....	9
Precautions	10
Safety when working with electricity	11
General observations	12
Typographical conventions used in this document.....	13
General conventions	13
1 General information.....	14
SmartNode 5200 overview	15
SmartNode 5200 rear panel	16
SmartNode 5200 front panel	17
2 Applications overview.....	18
Introduction.....	19
Typical application	19
3 SmartNode installation.....	20
Planning the installation.....	21
Site log	21
Network information	21
Network Diagram	21
IP related information	22
Software tools	22
Power source	22
Location and mounting requirements	22
Installing the gateway router.....	22
Placing the SmartNode	22
Installing cables	23
Connecting the 10/100Base-T Ethernet LAN and WAN cables	23
Connecting the power supply	23
4 Initial configuration.....	25
Introduction.....	26
Connecting the SmartNode to your laptop PC.....	26
Configuring the desired IP address	27
Factory-default IP settings	27
Login	27

Changing the WAN IP address	27
Connecting the SmartNode to the network.....	28
Loading the configuration (optional).....	29
Additional information.....	30
5 Contacting Patton for assistance	31
Introduction.....	32
Contact information.....	32
Patton support headquarters in the USA	32
Alternate Patton support for Europe, Middle East, and Africa (EMEA)	32
Warranty Service and Returned Merchandise Authorizations (RMAs).....	32
Warranty coverage	32
Out-of-warranty service	33
Returns for credit	33
Return for credit policy	33
RMA numbers	33
Shipping instructions	33
A Compliance information	34
Compliance.....	35
EMC	35
Low-Voltage Directive (Safety)	35
PSTN Regulatory	35
CE Declaration of Conformity.....	35
Authorized European Representative.....	35
B Specifications	36
Data connectivity	37
Voice signalling.....	37
IP services.....	37
Management	37
Operating environment.....	38
Operating temperature	38
Operating humidity	38
System.....	38
Dimensions	38
Weight and power dissipation	38
C Cabling	39
Introduction.....	40
Ethernet	40
D Port pin-outs	41
Introduction.....	42
Ethernet	42
E SmartNode 5200 factory configuration	43
Introduction.....	44

F End user license agreement	48
End User License Agreement	49
1. Definitions	49
2. Title	49
3. Term	49
4. Grant of License	49
5. Warranty	49
6. Termination	50
7. Other licenses	50

List of Figures

- 1 SmartNode 5200 15
- 2 SmartNode 5200 rear panel 16
- 3 SmartNode 5200 front panel 17
- 4 Internet telephony IAD application (SN5200 shown) 19
- 5 Router front panel LEDs 24
- 6 Connecting the SmartNode to your laptop PC 26
- 7 Connecting the SmartNode to the network 28
- 8 Typical Ethernet straight-through cable diagram 40

List of Tables

- 1 General conventions 13
- 2 Rear panel ports 16
- 3 SmartNode 5200 LED definitions 17
- 4 Sample site log entries 21
- 5 Factory default IP address and network mask configuration 27
- 6 SmartNode weight and maximum power specifications 38
- 7 RJ-45 socket 42

About this guide

This guide describes the SmartNode 5200 hardware, installation and basic configuration. For detailed software configuration information refer to the *SmartWare Software Configuration Guide* and the available Configuration Notes.

Audience

This guide is intended for the following users:

- Operators
- Installers
- Maintenance technicians

Structure

This guide contains the following chapters and appendices:

- [Chapter 1](#) on page 14 provides information about router features and capabilities
- [Chapter 2](#) on page 18 contains an overview describing router operation and applications
- [Chapter 3](#) on page 20 provides hardware installation procedures
- [Chapter 4](#) on page 25 provides initial procedures for configuring the SmartNode router
- [Chapter 5](#) on page 31 contains information on contacting Patton technical support for assistance
- [Appendix A](#) on page 34 contains compliance information for the SmartNode
- [Appendix B](#) on page 36 contains specifications for the routers
- [Appendix C](#) on page 39 provides cable recommendations
- [Appendix D](#) on page 41 describes the router's ports and pin-outs
- [Appendix E](#) on page 43 lists the factory configuration settings for SmartNode 5200
- [Appendix F](#) on page 48 provides license information that describes acceptable usage of the software provided with the SmartNode 5200

For best results, read the contents of this guide *before* you install the router.

Precautions

Notes, cautions, and warnings, which have the following meanings, are used throughout this guide to help you become aware of potential problems. **Warnings** are intended to prevent safety hazards that could result in personal injury. **Cautions** are intended to prevent situations that could result in property damage or impaired functioning.

Note A note presents additional information or interesting sidelights.



IMPORTANT

The alert symbol and IMPORTANT heading calls attention to important information.



CAUTION

The alert symbol and CAUTION heading indicate a potential hazard. Strictly follow the instructions to avoid property damage.



CAUTION

The shock hazard symbol and CAUTION heading indicate a potential electric shock hazard. Strictly follow the instructions to avoid property damage caused by electric shock.



WARNING

The alert symbol and WARNING heading indicate a potential safety hazard. Strictly follow the warning instructions to avoid personal injury.



WARNING

The shock hazard symbol and WARNING heading indicate a potential electric shock hazard. Strictly follow the warning instructions to avoid injury caused by electric shock.

Safety when working with electricity



- Do not open the device when the power cord is connected. For systems without a power switch and without an external power adapter, line voltages are present within the device when the power cord is connected.
- For devices with an external power adapter, the power adapter shall be a listed *Limited Power Source*. The mains outlet that is utilized to power the device shall be within 10 feet (3 meters) of the device, shall be easily accessible, and protected by a circuit breaker in compliance with local regulatory requirements.
- For AC powered devices, ensure that the power cable used meets all applicable standards for the country in which it is to be installed.
- For AC powered devices which have 3 conductor power plugs (L1, L2 & GND or Hot, Neutral & Safety/Protective Ground), the wall outlet (or socket) must have an earth ground.
- For DC powered devices, ensure that the interconnecting cables are rated for proper voltage, current, anticipated temperature, flammability, and mechanical serviceability.
- WAN, LAN & PSTN ports (connections) may have hazardous voltages present regardless of whether the device is powered ON or OFF. PSTN relates to interfaces such as telephone lines, FXS, FXO, DSL, xDSL, T1, E1, ISDN, Voice, etc. These are known as "hazardous network voltages" and to avoid electric shock use caution when working near these ports. When disconnecting cables for these ports, detach the far end connection first.
- Do not work on the device or connect or disconnect cables during periods of lightning activity



This device contains no user serviceable parts. This device can only be repaired by qualified service personnel.



This device is NOT intended nor approved for connection to the PSTN. It is intended only for connection to customer premise equipment.



In accordance with the requirements of council directive 2002/96/EC on Waste of Electrical and Electronic Equipment (WEEE), ensure that at end-of-life you separate this product from other waste and scrap and deliver to the WEEE collection system in your country for recycling.



Electrostatic Discharge (ESD) can damage equipment and impair electrical circuitry. It occurs when electronic printed circuit cards are improperly handled and can result in complete or intermittent failures. Do the following to prevent ESD:

- **Always follow ESD prevention procedures when removing and replacing cards.**
- **Wear an ESD-preventive wrist strap, ensuring that it makes good skin contact. Connect the clip to an unpainted surface of the chassis frame to safely channel unwanted ESD voltages to ground.**
- **To properly guard against ESD damage and shocks, the wrist strap and cord must operate effectively. If no wrist strap is available, ground yourself by touching the metal part of the chassis.**

General observations

- Clean the case with a soft slightly moist anti-static cloth
- Place the unit on a flat surface and ensure free air circulation
- Avoid exposing the unit to direct sunlight and other heat sources
- Protect the unit from moisture, vapors, and corrosive liquids

Typographical conventions used in this document

This section describes the typographical conventions and terms used in this guide.

General conventions

The procedures described in this manual use the following text conventions:

Table 1. General conventions

Convention	Meaning
Garamond blue type	Indicates a cross-reference hyperlink that points to a figure, graphic, table, or section heading. Clicking on the hyperlink jumps you to the reference. When you have finished reviewing the reference, click on the Go to Previous View button  in the Adobe® Acrobat® Reader toolbar to return to your starting point.
Futura bold type	Commands and keywords are in boldface font.
<i>Futura bold-italic type</i>	Parts of commands, which are related to elements already named by the user, are in boldface italic font.
<i>Italicized Futura type</i>	Variables for which you supply values are in <i>italic</i> font
Futura type	Indicates the names of fields or windows.
Garamond bold type	Indicates the names of command buttons that execute an action.
< >	Angle brackets indicate function and keyboard keys, such as <SHIFT>, <CTRL>, <C>, and so on.
[]	Elements in square brackets are optional.
{ a b c }	Alternative but required keywords are grouped in braces ({ }) and are separated by vertical bars ()
blue screen	Information you enter is in blue screen font.
screen	Terminal sessions and information the system displays are in screen font.
node	The leading IP address or nodename of a SmartNode is substituted with node in boldface italic font.
SN	The leading SN on a command line represents the nodename of the SmartNode
#	An hash sign at the beginning of a line indicates a comment line.

Chapter 1 **General information**

Chapter contents

SmartNode 5200 overview	15
SmartNode 5200 rear panel	16
SmartNode 5200 front panel	17

SmartNode 5200 overview

The SmartNode 5200 Enterprise Session Border Router (see [figure 1](#)) combines Ethernet switching, IP routing, VPN/Security, and Quality of Service with high-quality Voice over IP (VoIP) session control. This combination allows you to leverage low-cost Internet Telephony on existing IP-PBX equipment for complete SoHo and branch office voice and data connectivity.



Figure 1. SmartNode 5200

The SmartNode 5200 is equipped with a 10/100Base-T Ethernet WAN port and an integrated 4-port 10/100Base-T Ethernet switch.

The SmartNode 5200 Enterprise Session Border Router performs the following major functions:

- Standard compliant VoIP in accordance with SIP or H.323 protocols.
- Internet access and IP Routing with IP Quality of Service (QoS) support for mixed voice and data traffic.
- Enable universal SIP trunking for up to 32 SIP sessions

SmartNode 5200 rear panel

The SmartNode 5200 is a compact VoIP Gateway Router that supports 32 simultaneous SIP sessions. The SmartNode 5200 rear panel ports are described in [table 2](#).

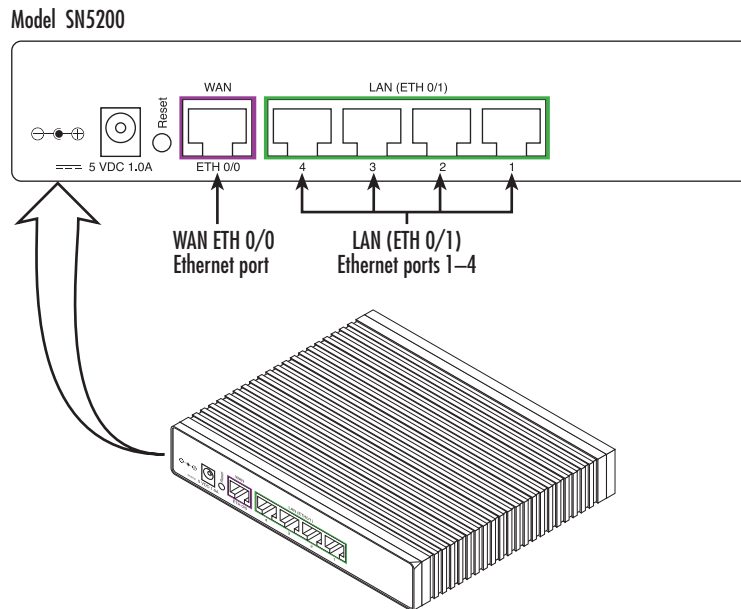

Figure 2. SmartNode 5200 rear panel

Table 2. Rear panel ports

Port	Description
WAN ETH 0/0	Auto-MDX Fast-Ethernet port, RJ-45 (see figure 2), connects the unit to an Ethernet WAN device (for example, a cable modem, DSL modem, or fiber modem).
LAN (ETH 0/1) 1-4	Switched Auto-MDX Fast-Ethernet ports, RJ-45 (see figure 2), connect the unit to an Ethernet LAN (for example, a PC, printer, or wireless bridge).
5V DC, 1.0A	The Model 5200 has a 5V DC power input (see figure 2).
Reset	<p>The reset button (see figure 2) has three functions:</p> <ul style="list-style-type: none"> Restart the unit with the current startup configuration—Press (for less than 1 second) and release the <i>Reset</i> button to restart the unit with the current startup configuration. Restart the unit with factory default configuration—Press the <i>Reset</i> button for 5 seconds until the <i>Power</i> LED (see figure 3 on page 17) starts blinking to restart the unit with factory default configuration. Restart the unit in bootloader mode (to be used only by trained SmartNode technicians)—Starting with the unit powered off, press and hold the <i>Reset</i> button as you apply power to the unit. Release the <i>Reset</i> button when the <i>Power</i> LED starts blinking so the unit will enter bootloader mode.

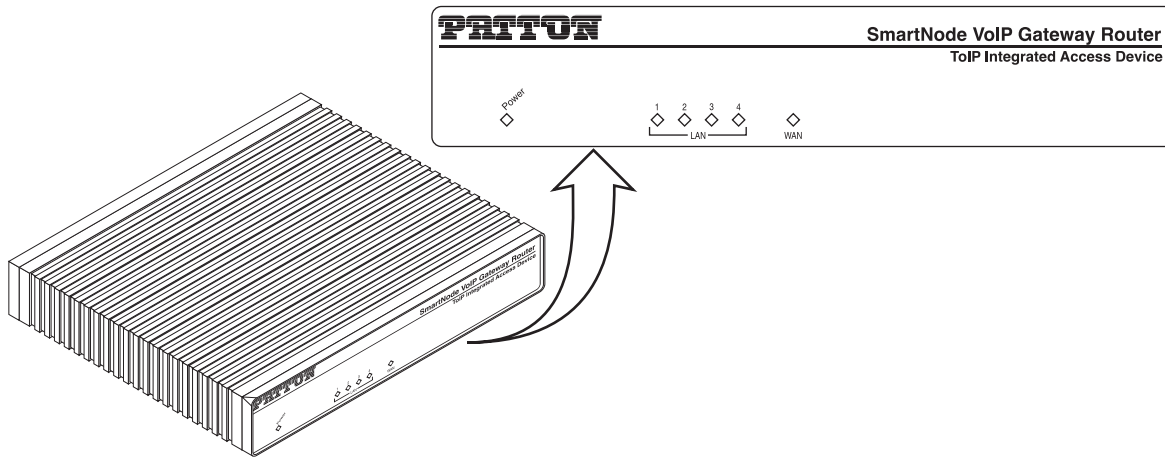

Figure 3. SmartNode 5200 front panel

SmartNode 5200 front panel

Figure 3 shows SmartNode 5200 LEDs, the LED definitions are listed in [table 3](#).

Table 3. SmartNode 5200 LED definitions

LED	Description
Note	If an error occurs, all LEDs will flash once per second.
Power	When lit, indicates power is applied and the unit is in normal operation. Off indicates no power applied. Flashes once per second during boot (startup).
VoIP Link	<ul style="list-style-type: none"> On indicates the gateway is registered to an H.323 gatekeeper/SIP server, or, in the case of direct routing, has at least one active VoIP connection. Off indicates the unit is not configured or registered, or has no active direct-routed VoIP connection. Flashing green indicates that the unit is attempting to register or has failed to register.
Ethernet (LAN 1-4 and WAN)	<ul style="list-style-type: none"> On when the Ethernet connection on the corresponding port has a link indication. Flashes when data is received or transmitted at the corresponding Ethernet port.

Chapter 2 **Applications overview**

Chapter contents

Introduction.....19
Typical application.....19

Introduction

Patton's SmartNode VoIP Enterprise Session Routers deliver the features you need for advanced multiservice voice and data network applications. They combine high quality voice-over-IP with powerful *quality of service* routing functions to build professional and reliable VoIP and data networks. This chapter describes typical applications for which this SmartNode is uniquely suited.

Note Detailed configuration information for the applications can be found on the CD-ROM that was included with your SmartNode device or online from the Patton webserver at www.patton.com.

Typical application

The SN5200 enables Universal SIP Trunking and provides a single Integrated Access Device with features like IP Routing, Redundancy, Security and a SIP registrar for survivability. The Enterprise can use a single conduit for both its voice and data traffic thus making the most cost efficient use of its resources. By using two SN5200 with VRRP enabled an Enterprise could connect to two ITSP and provide for failover incase the primary SIP provider trunk has a problem.

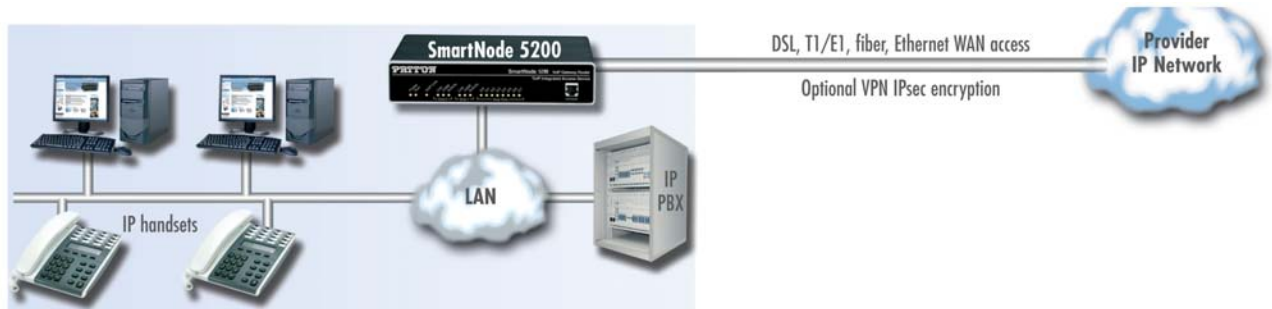

Figure 4. Internet telephony IAD application (SN5200 shown)

Broadband network connectivity integrates with any fixed IP, DHCP or PPPoE service. An integrated 10/100 Ethernet LAN switch, with advanced routing features such as NAT, Firewall/ACL, DynDNS as well as optional IPsec VPN, fulfills the requirements of demanding network users.

Quality of Service (QoS) features complete the offering with advanced voice prioritization and traffic management. Patton's patent-pending DownStreamQoS™ ensures voice without interruptions even over best-effort Internet connections.

Chapter 3 **SmartNode installation**

Chapter contents

Planning the installation	21
Site log	21
Network information	21
Network Diagram	21
IP related information	22
Software tools	22
Power source	22
Location and mounting requirements	22
Installing the gateway router.....	22
Placing the SmartNode	22
Installing cables	23
Connecting the 10/100Base-T Ethernet LAN and WAN cables	23
Connecting the power supply	23

Planning the installation



The mains outlet that is utilized to power the equipment must be within 10 feet (3 meters) of the device and shall be easily accessible.

Before installing the gateway router device, the following tasks should be completed:

- **Create a network diagram** (see section “[Network information](#)” on page 21)
- **Gather IP related information** (see section “[IP related information](#)” on page 22 for more information)
- **Install the hardware and software needed to configure the SmartNode.** (See section “[Software tools](#)” on page 22)
- **Verify power source reliability** (see section “[Power source](#)” on page 22).

After you have finished preparing for gateway router installation, go to section “[Installing the gateway router](#)” on page 22 to install the device.

Site log

Patton recommends that you maintain a site log to record all actions relevant to the system, if you do not already keep such a log. Site log entries should include information such as listed in [table 4](#).

Table 4. Sample site log entries

Entry	Description
Installation	Make a copy of the installation checklist and insert it into the site log
Upgrades and maintenance	Use the site log to record ongoing maintenance and expansion history
Configuration changes	Record all changes and the reasons for them
Maintenance	Schedules, requirements, and procedures performed
Comments	Notes, and problems
Software	Changes and updates to SmartWare software

Network information

Network connection considerations that you should take into account for planning are provided for several types of network interfaces are described in the following sections.

Network Diagram

Draw a network overview diagram that displays all neighboring IP nodes, connected elements and telephony components.

IP related information

Before you can set up the basic IP connectivity for your SmartNode 5200 you should have the following information:

- IP addresses used for Ethernet LAN and WAN ports
- Subnet mask used for Ethernet LAN and WAN ports
- IP addresses of central H.323 gatekeeper (if used)
- IP addresses and/or URL of SIP servers or Internet telephony services (if used)
- Login and password for PPPoE Access
- Login and password for SIP or H.323 based telephony services
- IP addresses of central TFTP server used for configuration upload and download (optional)

Software tools

You will need a PC (or equivalent) with Windows Telnet or a program such as *Tera Term Pro Web* (included on the SmartNode CD-ROM) to configure the software on your SmartNode router.

Power source

If you suspect that your AC power is not reliable, for example if room lights flicker often or there is machinery with large motors nearby, have a qualified professional test the power. Patton recommends that you include an uninterruptible power supply (UPS) in the installation to ensure that VoIP service is not impaired if the power fails.

Location and mounting requirements

The SmartNode router is intended to be placed on a desktop or similar sturdy, flat surface that offers easy access to the cables. Allow sufficient space at the rear of the chassis for cable connections. Additionally, you should consider the need to access the unit for future upgrades and maintenance.

Installing the gateway router

SmartNode hardware installation consists of the following:

- Placing the device at the desired installation location (see section “[Placing the SmartNode](#)”)
- Connecting the interface and power cables (see section “[Installing cables](#)” on page 23)

When you finish installing the SmartNode, go to chapter 4, “[Initial configuration](#)” on page 25.

Placing the SmartNode

Place the unit on a desktop or similar sturdy, flat surface that offers easy access to the cables. The unit should be installed in a dry environment with sufficient space to allow air circulation for cooling.

Note For proper ventilation, leave at least 2 inches (5 cm) to the left, right, front, and rear of the unit.

Installing cables



Do not work on the system or connect or disconnect cables during periods of lightning activity.

Connect the cables in the following order:

1. Connect the 10/100Base-T Ethernet LAN and WAN (see section “[Connecting the 10/100Base-T Ethernet LAN and WAN cables](#)” on page 23)
2. Connect the power supply (see section “[Connecting the power supply](#)” on page 23)

Connecting the 10/100Base-T Ethernet LAN and WAN cables

The SmartNode 5200 has automatic MDX (auto-crossover) detection and configuration on all Ethernet ports. Any of the ports can be connected to a host or hub/switch with a straight-through wired cable.

1. Connect port ETH 0/0 to the subscriber port of the broadband access modem (DSL, cable, WLL).
2. Connect Ethernet ports 1 to 4 to your LAN devices (PC, printer, switches, etc.)

For details on the Ethernet port pinout and cables, refer to [Appendix C, “Cabling”](#) on page 39 and [Appendix D, “Port pin-outs”](#) on page 41.

Connecting the power supply

Do the following to connect the power supply to the Model 5200:

Note *Do not connect the power cord to the AC power outlet at this time.*

1. Insert the barrel-type connector end of the AC power supply into the *5V DC, 1.0A* port (see [figure 2](#) on page 16).



The external router power supply automatically adjusts to accept an input voltage from 100 to 240 VAC (50/60 Hz).

Verify that the proper voltage is present before plugging the power cord into the receptacle. Failure to do so could result in equipment damage.

2. Verify that the AC power cord included with your router is compatible with local standards. If it is not, refer to “[Contacting Patton for assistance](#)” on page 31 to find out how to replace it with a compatible power cord.
3. Connect the male end of the AC power supply power cord to an appropriate AC power outlet.

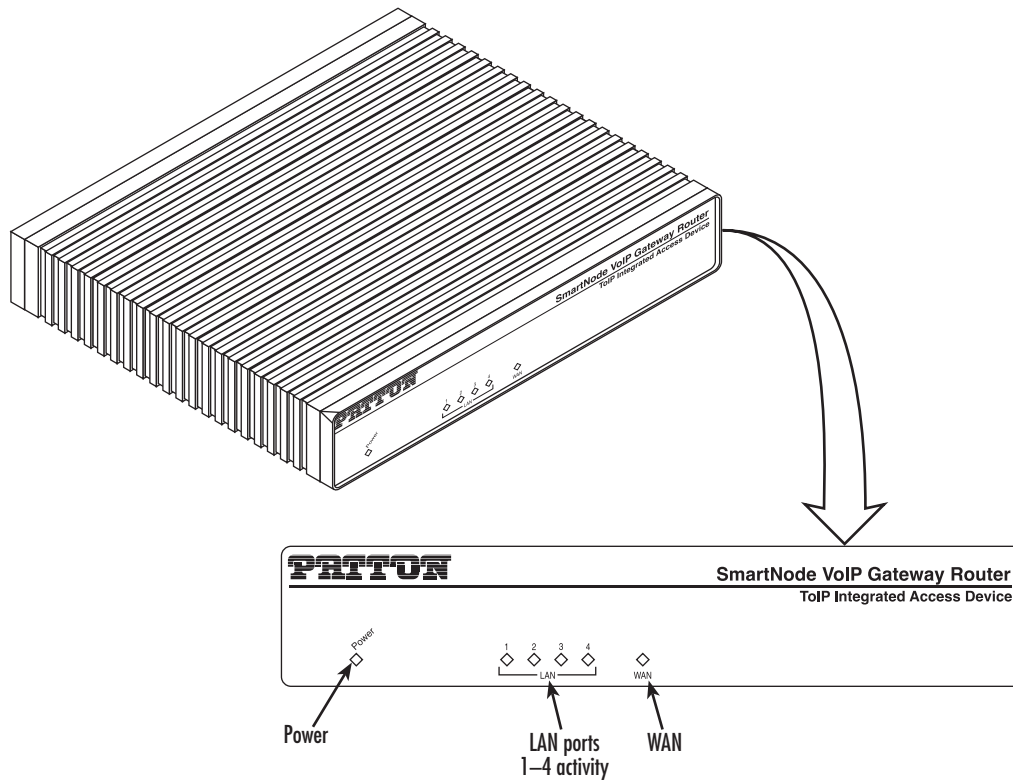

Figure 5. Router front panel LEDs

4. Verify that the green *Power* LED is lit (see [figure 5](#)).

Congratulations, you have finished installing the SmartNode Gateway Router! Now go to chapter 4, “[Initial configuration](#)” on page 25.

Chapter 4 **Initial configuration**

Chapter contents

Introduction.....	26
Connecting the SmartNode to your laptop PC.....	26
Configuring the desired IP address	27
Factory-default IP settings	27
Login	27
Changing the WAN IP address	27
Connecting the SmartNode to the network.....	28
Loading the configuration (optional).....	29
Additional information.....	30

Introduction

This chapter leads you through the basic steps to set up a new SmartNode and to download a configuration. Setting up a new SmartNode consists of the following main steps:

Note If you haven't already installed the SmartNode, refer to chapter 3, "SmartNode installation" on page 20.

- Connecting the SmartNode to your laptop PC
- Configuring the desired IP address
- Connecting the SmartNode to the network
- Loading the configuration (optional)

Note The SmartNode CD-ROM contains a collection of third party software tools (including TFTP servers and Telnet utilities) to help you configure, operate and monitor the SmartNode device.

Connecting the SmartNode to your laptop PC

First the SmartNode must be connected to the mains power supply with the power cable. Wait until the *Power* LED stops blinking and stays lit constantly. Now the SmartNode is ready.



CAUTION

The interconnecting cables shall be acceptable for external use and shall be rated for the proper application with respect to voltage, current, anticipated temperature, flammability, and mechanical serviceability.

The SmartNode 5200 Series is equipped with Auto-MDX Ethernet ports, so you can use straight-through cables for host or hub/switch connections (see figure 6).

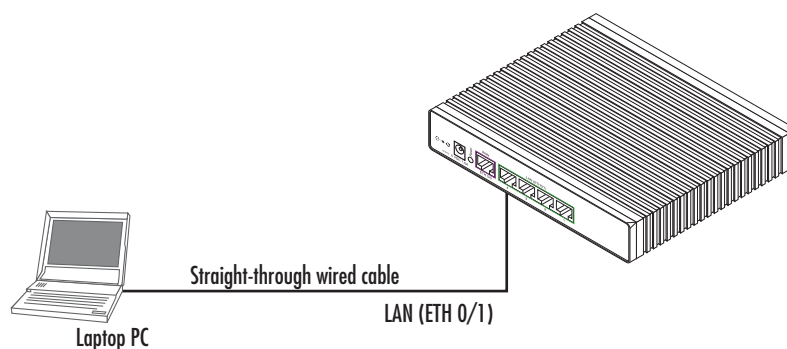

Figure 6. Connecting the SmartNode to your laptop PC

The SmartNode comes with a built-in DHCP server to simplify configuration. Therefore, to automatically configure the PC for IP connectivity to the SmartNode, the laptop PC must be configured for DHCP. The SmartNode will provide the PC with an IP address. You can check the connection to the SmartNode by executing the ping command from the PC command window as follows:

```
ping 192.168.1.1
```

Configuring the desired IP address

Factory-default IP settings

The factory default configuration for the Ethernet interface IP addresses and network masks are listed in [table 5](#). Both Ethernet interfaces are activated upon power-up. LAN interface *ETH 0/1 (LAN)* provides a default DHCP server, the WAN interface uses DHCP client to automatically assign the IP address and network mask.

Table 5. Factory default IP address and network mask configuration

	IP Address	Network Mask
WAN interface Ethernet 0 (ETH 0/0)	DHCP	DHCP
LAN interface Ethernet 1 (ETH 0/1)	192.168.1.1	255.255.255.0
DHCP address range	192.168.1.10–192.168.1.19	255.255.255.0

If these addresses match with those of your network, go to section “[Connecting the SmartNode to the network](#)” on page 28. Otherwise, refer to the following sections to change the addresses and network masks.

Login

To access the SmartNode, start the Telnet application. Type the default IP address for the router into the address field: **192.168.1.1**. Accessing your SmartNode via a Telnet session displays the login screen. Type the factory default login: *administrator* and leave the password empty. Press the *Enter* key after the password prompt.

```
login:administrator
password: <Enter>
192.168.1.1>
```

After you have successfully logged in you are in the operator execution mode, indicated by > as command line prompt. With the commands *enable* and *configure* you enter the configuration mode.

```
192.168.1.1>enable
192.168.1.1#configure
192.168.1.1(cfg)#
```

Changing the WAN IP address

Select the context IP mode to configure an IP interface.

```
192.168.1.1(cfg)#context ip router
192.168.1.1(ctx-ip)[router]#
```

Now you can set your IP address and network mask for the interface *ETH 0/0* (*WAN*). Within this example a network 172.16.1.0/24 address is assumed. The IP address in this example is set to 172.16.1.99 (you should set this the IP address given to you by your network provider).

```
192.168.1.1(ctx-ip)[router]#interface eth0
192.168.1.1(if-ip)[eth0]#ipaddress 172.16.1.99 255.255.255.0
2002-10-29T00:09:40 : LOGINFO      : Link down on interface eth0.
2002-10-29T00:09:40 : LOGINFO      : Link up on interface eth0.
172.16.1.99(if-ip)[eth0]#
```

Copy this modified configuration to your new start-up configuration. This will store your changes in non-volatile memory. Upon the next start-up the system will initialize itself using the modified configuration.

```
172.16.1.99(if-ip)[eth0]#copy running-config startup-config
172.16.1.99(if-ip)[eth0]#
```

The SmartNode can now be connected to your network.

Connecting the SmartNode to the network

In general, the SmartNode will connect to the network via the *WAN* (*ETH 0/0*) port. This enables the SmartNode to offer routing services to the PC hosts on *LAN* (*ETH 0/1*) port. The SmartNode 5200 Series is equipped with Auto-MDX Ethernet ports, so you can use straight-through or crossover cables for host or hub/switch connections (see [figure 7](#)).



The interconnecting cables shall be acceptable for external use and shall be rated for the proper application with respect to voltage, current, anticipated temperature, flammability, and mechanical serviceability.

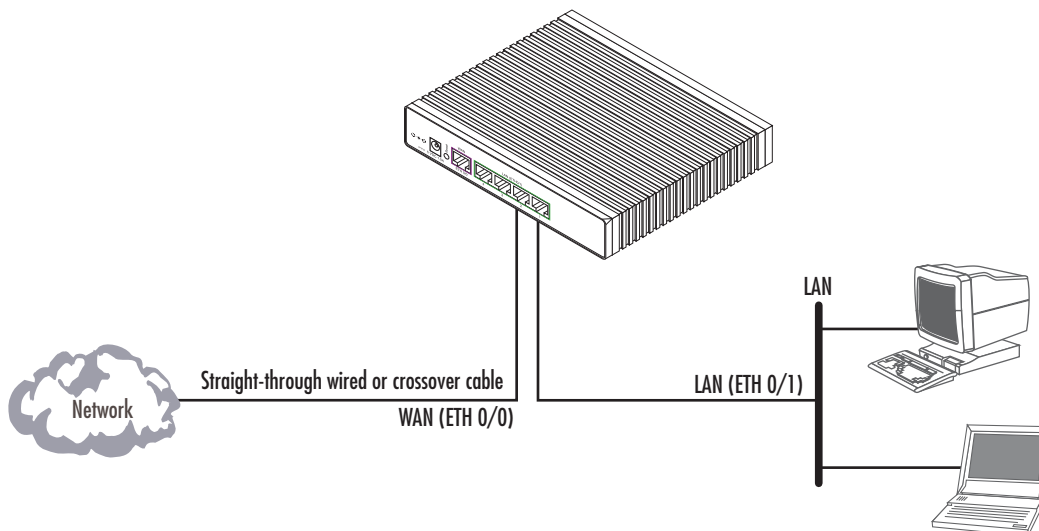

Figure 7. Connecting the SmartNode to the network

You can check the connection with the ping command from the SmartNode to another host on the network.

```
172.16.1.99(if-ip)[eth0]#ping <IP Address of the host>
```

Note If the WAN address is *not* set to DHCP, to ping a device outside your local LAN you must first configure the default gateway. (For information on configuring the default gateway, refer to section “Set IP addresses” in Appendix C, “Command Summary” of the *SmartNode Series SmartWare Software Configuration Guide*.)

Loading the configuration (optional)

Patton provides a collection of configuration templates on the CD-ROM that came with the SmartNode device—and also on the support page at www.patton.com/voip—one of which may be similar enough to your application that you can use it to speed up configuring the SmartNode. Simply download the configuration note that matches your application to your PC. Adapt the configuration as described in the configuration note to your network (remember to modify the IP address) and copy the modified configuration to a TFTP server. The SmartNode can now load its configuration from this server.

Note Patton regularly adds new configuration templates to the collection at www.patton.com/voip, so if you do not see your application on the CD-ROM, it may have been added to the website.

Note If your application is unique and not covered by any of Patton’s configuration templates, you can manually configure the SmartNode instead of loading a configuration file template. In that case, refer to the *SmartNode Series SmartWare Software Configuration Guide* for information on configuring the SmartNode device.

In this example we assume the TFTP server on the host with the IP address 172.16.1.11 and the configuration named *SN.cfg* in the root directory of the TFTP server.

```
172.16.1.99(if-ip)[eth0]#copy tftp://172.16.1.11/SN.cfg startup-config
Download...100%
172.16.1.99(if-ip)[eth0]#
```

After the SmartNode has been rebooted the new startup configuration will be activated.



When you issue the **reload** command, the SmartNode will ask if you want to copy the running configuration to the startup configuration. Since you just downloaded a configuration file to the startup configuration you must answer this question with **NO**. Otherwise, the downloaded configuration will be overwritten and lost!

```
172.16.1.99(if-ip)[eth0]#reload
Running configuration has been changed.
Do you want to copy the 'running-config' to the 'startup-config'?
Press 'yes' to store, 'no' to drop changes : no
Press 'yes' to restart, 'no' to cancel : yes
The system is going down
```

Additional information

For detailed information about configuring and operating guidance, set up procedures, and troubleshooting, refer to the *SmartNode Series SmartWare Software Configuration Guide* on the CD-ROM.

Chapter 5 **Contacting Patton for assistance**

Chapter contents

- Introduction.....32
- Contact information.....32
 - Patton support headquarters in the USA32
 - Alternate Patton support for Europe, Middle East, and Africa (EMEA)32
- Warranty Service and Returned Merchandise Authorizations (RMAs).....32
 - Warranty coverage32
 - Out-of-warranty service33
 - Returns for credit33
 - Return for credit policy33
 - RMA numbers33
 - Shipping instructions33

Introduction

This chapter contains the following information:

- “Contact information”—describes how to contact Patton technical support for assistance.
- “Warranty Service and Returned Merchandise Authorizations (RMAs)”—contains information about the RAS warranty and obtaining a return merchandise authorization (RMA).

Contact information

Patton Electronics offers a wide array of free technical services. If you have questions about any of our other products we recommend you begin your search for answers by using our technical knowledge base. Here, we have gathered together many of the more commonly asked questions and compiled them into a searchable database to help you quickly solve your problems.

Patton support headquarters in the USA

- Online support: available at www.patton.com
- E-mail support: e-mail sent to support@patton.com will be answered within 1 business day
- Telephone support: standard telephone support is available five days a week—from 8:00 am to 5:00 pm EST (1300 to 2200 UTC/GMT)—by calling +1 (301) 975-1007
- Fax: +1 (253) 663-5693

Alternate Patton support for Europe, Middle East, and Africa (EMEA)

- Online support: available at www.patton-inalp.com
- E-mail support: e-mail sent to support@patton-inalp.com will be answered within 1 business day
- Telephone support: standard telephone support is available five days a week—from 8:00 am to 5:00 pm CET (0900 to 1800 UTC/GMT)—by calling +41 (0)31 985 25 55
- Fax: +41 (0)31 985 25 26

Warranty Service and Returned Merchandise Authorizations (RMAs)

Patton Electronics is an ISO-9001 certified manufacturer and our products are carefully tested before shipment. All of our products are backed by a comprehensive warranty program.

Note If you purchased your equipment from a Patton Electronics reseller, ask your reseller how you should proceed with warranty service. It is often more convenient for you to work with your local reseller to obtain a replacement. Patton services our products no matter how you acquired them.

Warranty coverage

Our products are under warranty to be free from defects, and we will, at our option, repair or replace the product should it fail within one year from the first date of shipment. Our warranty is limited to defects in workmanship or materials, and does not cover customer damage, lightning or power surge damage, abuse, or unauthorized modification.

Out-of-warranty service

Patton services what we sell, no matter how you acquired it, including malfunctioning products that are no longer under warranty. Our products have a flat fee for repairs. Units damaged by lightning or other catastrophes may require replacement.

Returns for credit

Customer satisfaction is important to us, therefore any product may be returned with authorization within 30 days from the shipment date for a full credit of the purchase price. If you have ordered the wrong equipment or you are dissatisfied in any way, please contact us to request an RMA number to accept your return. Patton is not responsible for equipment returned without a Return Authorization.

Return for credit policy

- Less than 30 days: No Charge. Your credit will be issued upon receipt and inspection of the equipment.
- 30 to 60 days: We will add a 20% restocking charge (crediting your account with 80% of the purchase price).
- Over 60 days: Products will be accepted for repairs only.

RMA numbers

RMA numbers are required for all product returns. You can obtain an RMA by doing one of the following:

- Completing a request on the RMA Request page in the *Support* section at **www.patton.com**
- By calling **+1 (301) 975-1007** and speaking to a Technical Support Engineer
- By sending an e-mail to **returns@patton.com**

All returned units must have the RMA number clearly visible on the outside of the shipping container. Please use the original packing material that the device came in or pack the unit securely to avoid damage during shipping.

Shipping instructions

The RMA number should be clearly visible on the address label. Our shipping address is as follows:

Patton Electronics Company

RMA#: xxxx

7622 Rickenbacker Dr.

Gaithersburg, MD 20879-4773 USA

Patton will ship the equipment back to you in the same manner you ship it to us. Patton will pay the return shipping costs.

Appendix A **Compliance information**

Chapter contents

- Compliance35
 - EMC35
 - Low-Voltage Directive (Safety)35
 - PSTN Regulatory35
- CE Declaration of Conformity35
- Authorized European Representative35

Compliance

EMC

- EN55022, Class A
- EN55024

Low-Voltage Directive (Safety)

- IEC/EN60950-1, 2nd edition
- AS/NZS60950-1

PSTN Regulatory

- TBR 3:1995 A1
- AS/ACIF S031:2001

CE Declaration of Conformity

This device conforms to the requirements of Council Directive 1999/5/EC on the approximation of the laws of the member states relating to Radio and Telecommunication Terminal Equipment and the mutual recognition of their conformity.

The safety advice in the documentation accompanying this device shall be obeyed. The conformity to the above directive is indicated by CE mark on the device.

Authorized European Representative

D R M Green

European Compliance Services Limited.

Avalon House, Marcham Road

Abingdon,

Oxon OX14 1UD, UK

Appendix B **Specifications**

Chapter contents

- Data connectivity37
- Voice signalling37
- IP services37
- Management37
- Operating environment38
 - Operating temperature38
 - Operating humidity38
- System38
- Dimensions38
- Weight and power dissipation38

Note Refer to the software feature matrix for the most up-to-date specifications.

Data connectivity

10/100Base-TX Ethernet WAN port
4-port 10/100Base-TX Ethernet LAN switch
All ports full duplex, autosensing, auto-MDX

Voice signalling

SIPv2
H.323v4
SIP call transfer, redirect
Overlap or en-bloc dialing
DTMF in-band, out-of-band
Configurable progress tones

IP services

IPv4 router; RIPv1, v2 (RFC 1058 and 2453)
Programmable static routes
ICMP redirect (RFC 792); Packet fragmentation
DiffServe/ToS set or queue per header bits
Pocket Policing discards excess traffic
802.1p VLAN tagging
IPSEC AH & ESP Modes
Manual Key; IKE optional
AES/DES/3DES Encryption

Note To use the IPsec VPN capabilities including AES/DES/3DES encryption with the SmartNode 5200, you may need to purchase additional license keys.

Note The SmartNode 4562 is loaded with the VPN license from the factory.

Management

Industry standard CLI with remote Telnet access
HTTP web management and firmware loading
TFTP configuration & firmware loading
SNMP v1 agent (MIB II and private MIB)

Built-in diagnostic tools (trace, debug)

Operating environment

Operating temperature

32–104°F (0–40°C)

Operating humidity

5–80% (non condensing)

System

CPU Motorola MC875 operating at 66 MHz

Memory:

- 16 Mbytes SDRAM
- 4 Mbytes Flash

Dimensions

7.3W x 1.6H x 6.1D in. (18.5H x 4.1W x 15.5D cm)

Weight and power dissipation

See [table 6](#).

Table 6. SmartNode weight and maximum power specifications

SmartNode model	Weight	Maximum power dissipation
SN5200	30.5 oz./500 g	5W

Appendix C **Cabling**

Chapter contents

Introduction.....	40
Ethernet	40

Introduction

This section provides information on the cables used to connect the SmartNode and the interface cards to the existing network infrastructure and to third party products.

Ethernet

Ethernet devices (10Base-T/100Base-T) are connected to the SmartNode over a cable with RJ-45 plugs. All Ethernet ports on the SN5200 & SN4562 are Auto-MDX and use any straight or crossover cable to connect to hubs, switches, PCs or other devices.

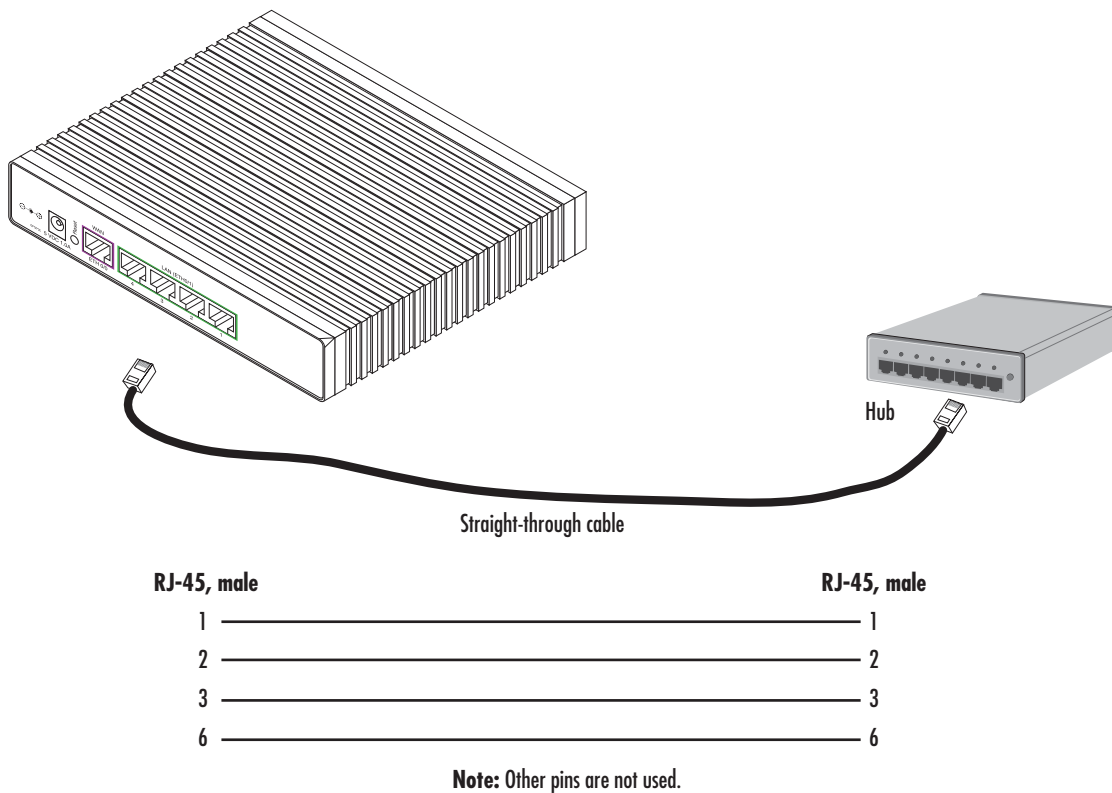

Figure 8. Typical Ethernet straight-through cable diagram

Appendix D **Port pin-outs**

Chapter contents

Introduction.....	42
Ethernet	42

Introduction

This section provides pin-out information for the ports of the SmartNode.

Ethernet

Table 7. RJ-45 socket

Pin	Signal
1	TX+
2	TX-
3	RX+
6	RX-

Note Pins not listed are not used.

Appendix E **SmartNode 5200 factory configuration**

Chapter contents

Introduction.....	44
-------------------	----

Introduction

The factory configuration settings for SmartNode 5200 are as follows:

```
#-----#
#
# 5200
# R3.xx BUILDxxxxx SIP
# 2005-08-25T00:00:00
# Factory configuration file
#
#-----#

dns-client server 10.56.128.44
dns-relay
webserver port 80 language en
sntp-client
sntp-client server primary 129.132.2.21 port 123 version 4
system hostname AA1

system

    ic voice 0
        low-bitrate-codec g729

profile napt NAPT

profile voip default
    codec 1 g711alaw64k rx-length 20 tx-length 20
    codec 2 g711ulaw64k rx-length 20 tx-length 20
    dtmf-relay rtp
    rtp traffic-class local-default

profile pstn default

profile ringing-cadence default
    play 1 1000
    pause 2 4000

profile sip default

profile dhcp-server DHCP
    network 192.168.1.0 255.255.255.0
    include 1 192.168.1.10 192.168.1.99
    lease 2 hours
```

```
default-router 1 192.168.1.1
domain-name-server 1 192.168.1.1

profile aaa default
method 1 local
method 2 none

context ip router

interface eth0
ipaddress 10.10.10.10 255.255.254.0
use profile napt NAPT
tcp adjust-mss rx mtu
tcp adjust-mss tx mtu

interface eth1
ipaddress 192.168.1.1 255.255.255.0
tcp adjust-mss rx mtu
tcp adjust-mss tx mtu

context ip router
dhcp-server use profile DHCP

context cs switch

routing-table called-e164 fromSIPWAN
route default dest-service SERVICE-SIP-LAN

routing-table called-e164 fromSIPLAN
route 3.... dest-service SERVICE-SIP-LAN
route default dest-interface SIP-WAN

interface sip SIP-WAN
bind context sip-gateway GWSIP-WAN
route call dest-table fromSIPWAN
remote sip.local.com

interface sip SIP-LAN
bind context sip-gateway GWSIP-LAN
route call dest-table fromSIPLAN
local 10.10.10.10

service sip-location-service SERVICE-SIP-LAN
bind location-service LS-LAN

context cs switch
no shutdown

authentication-service AUTHSERV
username 37060 password qHDk6Ej6cAk= encrypted
username 37061 password qHDk6Ej6cAk= encrypted
username 37062 password qHDk6Ej6cAk= encrypted
username 37063 password qHDk6Ej6cAk= encrypted
```

```
location-service LS-LAN
  domain 1 10.10.10.10

  identity 37060

    authentication outbound
      authenticate 1 authentication-service AUTHSERV username 37060

    authentication inbound
      authenticate 1 authentication-service AUTHSERV username 37060

    registration inbound

  identity 37061

    authentication outbound
      authenticate 1 authentication-service AUTHSERV username 37061

    authentication inbound
      authenticate 1 authentication-service AUTHSERV username 37061

    registration inbound

  identity 37062

    authentication outbound
      authenticate 1 authentication-service AUTHSERV username 37062

    authentication inbound
      authenticate 1 authentication-service AUTHSERV username 37062

    registration inbound

  identity 37063

    authentication outbound
      authenticate 1 authentication-service AUTHSERV username 37063

    authentication inbound
      authenticate 1 authentication-service AUTHSERV username 37063

    registration inbound

location-service LS-WAN
  domain 1 sip.local.com

  identity-group IDENT-GROUP-WAN

    authentication outbound
      authenticate 1 authentication-service AUTHSERV

    registration outbound
      registrar sip.local.com
      register auto
```

```
    call outbound

    call inbound

identity 37060 inherits IDENT-GROUP-WAN

    registration outbound

identity 37061 inherits IDENT-GROUP-WAN

    registration outbound

identity 37062 inherits IDENT-GROUP-WAN

    registration outbound

identity 37063 inherits IDENT-GROUP-WAN

    registration outbound

context sip-gateway GWSIP-WAN

    interface ifwan
        bind interface eth0 context router port 5062

context sip-gateway GWSIP-WAN
    bind location-service LS-WAN
    no shutdown

context sip-gateway GWSIP-LAN

    interface iflan
        bind interface eth0 context router port 5060

context sip-gateway GWSIP-LAN
    bind location-service LS-LAN
    no shutdown

port ethernet 0 0
    medium auto
    encapsulation ip
    bind interface eth0 router
    no shutdown

port ethernet 0 1
    medium auto
    encapsulation ip
    bind interface eth1 router
    no shutdown
```

Appendix F **End user license agreement**

Chapter contents

End User License Agreement	49
1. Definitions	49
2. Title	49
3. Term	49
4. Grant of License	49
5. Warranty	49
6. Termination	50
7. Other licenses	50

End User License Agreement

By opening this package, operating the Designated Equipment or downloading the Program(s) electronically, the End User agrees to the following conditions:

1. Definitions

- A) *Effective Date* shall mean the earliest date of purchase or download of a product containing the Patton Electronics Company Program(s) or the Program(s) themselves.
- B) *Program(s)* shall mean all software, software documentation, source code, object code, or executable code.
- C) *End User* shall mean the person or organization which has valid title to the Designated Equipment.
- D) *Designated Equipment* shall mean the hardware on which the Program(s) have been designed and provided to operate by Patton Electronics Company.

2. Title

Title to the Program(s), all copies of the Program(s), all patent rights, copyrights, trade secrets and proprietary information in the Program(s), worldwide, remains with Patton Electronics Company or its licensors.

3. Term

The term of this Agreement is from the Effective Date until title of the Designated Equipment is transferred by End User or unless the license is terminated earlier as defined in section “6. Termination” on page 50.

4. Grant of License

- A) During the term of this Agreement, Patton Electronics Company grants a personal, non-transferable, non-assignable and non-exclusive license to the End User to use the Program(s) only with the Designated Equipment at a site owned or leased by the End User.
- B) The End User may copy licensed Program(s) as necessary for backup purposes only for use with the Designated Equipment that was first purchased or used or its temporary or permanent replacement.
- C) The End User is prohibited from disassembling; decompiling, reverse-engineering or otherwise attempting to discover or disclose the Program(s), source code, methods or concepts embodied in the Program(s) or having the same done by another party.
- D) Should End User transfer title of the Designated Equipment to a third party after entering into this license agreement, End User is obligated to inform the third party in writing that a separate End User License Agreement from Patton Electronics Company is required to operate the Designated Equipment.

5. Warranty

The Program(s) are provided *as is* without warranty of any kind. Patton Electronics Company and its licensors disclaim all warranties, either express or implied, including but not limited to the implied warranties of merchantability, fitness for a particular purpose or non-infringement. In no event shall Patton Electronics Company or its licensors be liable for any damages whatsoever (including, without limitation, damages for loss of business profits, business interruption, loss of business information, or other pecuniary loss) arising out of the use of or inability to use the Program(s), even if Patton Electronics Company has been advised of the possibility of such damages. Because some states do not allow the exclusion or limitation of liability for consequential or incidental damages, the above limitation may not apply to you.

If the Program(s) are acquired by or on behalf of a unit or agency of the United States Government, the Government agrees that such Program(s) are *commercial computer software* or *computer software documentation* and that, absent a written agreement to the contrary, the Government's rights with respect to such Program(s) are limited by the terms of this Agreement, pursuant to Federal Acquisition Regulations 12.212(a) and/or DEARS 227.7202-1(a) and/or sub-paragraphs (a) through (d) of the "Commercial Computer Software - Restricted Rights" clause at 48 C.F.R. 52.227-19 of the Federal Acquisition Regulations as applicable.

6. Termination

- A) The End User may terminate this agreement by returning the Designated Equipment and destroying all copies of the licensed Program(s).
- B) Patton Electronics Company may terminate this Agreement should End User violate any of the provisions of section "4. Grant of License" on page 49.
- C) Upon termination for A or B above or the end of the Term, End User is required to destroy all copies of the licensed Program(s)

7. Other licenses

The Program may be subject to licenses extended by third parties. Accordingly, Patton Electronics Company licenses the Programs subject to the terms and conditions dictated by third parties. Third party software identified to the Programs includes:

- A routing license is included at no charge.
- MGCP and VPN capabilities will require the purchase of an additional license.
- The LGPL (Lesser General Public License) open source license distributed to you pursuant to the LGPL license terms (<http://www.gnu.org/licenses/lgpl.html>).
- RedBoot (Red Hat Embedded Debug and Bootstrap) embedded system debug/bootstrap environment from Red Hat distributed to you pursuant to the eCos license terms (<http://ecos.sourceware.org/license-overview.html>) and GNU General Public License (GPL) terms (<http://www.gnu.org/copyleft/gpl.html>). Source code is available upon request.