

USER MANUAL

Model 2135
Ethernet Micro-Bridge



PA PATTON
Electronics Co.



An ISO-9001
Certified
Company

Part# 07M2135-UM
Doc# 08303U2-001,
Rev. B
Revised 10/26/06

SALES OFFICE
(301) 975-1000
TECHNICAL SUPPORT
(301) 975-1007
<http://www.patton.com>

TABLE OF CONTENTS

<u>Section</u>	<u>Page</u>
1.0 Warranty Information	2
1.1 Radio and TV Interference	
1.2 CE Notice	
1.3 Service	
2.0 General Information	4
2.1 Features	
2.2 Description	
3.0 PPP Operational Background.....	5
3.1 Applications	
4.0 Installation	7
4.1 Connect to 10BaseT Ethernet Port	
4.1.1 Connect the 10BaseT Ethernet Port to a Hub	
4.1.2 Connect the 10BaseT Ethernet Port to a PC (DTE)	
4.2 Connect to the DTE Interface	
4.3 Power Connection	
4.3.1 AC Power Supply (100-240VAC)	
4.3.2 DC Power	
5.0 Configuration	9
5.1 LED Status Monitors	
5.1.1 LAN side LEDs	
5.1.2 LED Descriptions	
5.1.3 Power and DCE/DTE Interface LEDs	
Appendix A - Specifications	12
Appendix B - Factory Replacement Parts	13
Appendix C - 10BaseT Interface Pin Assignment	14
Appendix D - Terminal Interface Pin Assignment	15
Appendix E - Power Supply Interface.....	16

1.0 WARRANTY INFORMATION

Patton Electronics warrants all Model 2135 components to be free from defects, and will—at our option—repair or replace the product should it fail within one year from the first date of shipment.

This warranty is limited to defects in workmanship or materials, and does not cover customer damage, abuse or unauthorized modification. If this product fails or does not perform as warranted, your sole recourse shall be repair or replacement as described above. Under no condition shall Patton Electronics be liable for any damages incurred by the use of this product. These damages include, but are not limited to, the following: lost profits, lost savings and incidental or consequential damages arising from the use of or inability to use this product. Patton Electronics specifically disclaims all other warranties, expressed or implied, and the installation or use of this product shall be deemed an acceptance of these terms by the user.

1.1 RADIO AND TV INTERFERENCE

The Model 2135 generates and uses radio frequency energy, and if not installed and used properly—that is, in strict accordance with the manufacturer's instructions—may cause interference to radio and television reception. The Model 2135 has been tested and complies with the limits for a Class A computing device in accordance with the specification in Subpart J of Part 15 of FCC rules, that are designed to provide reasonable protection from such interference in a commercial installation. However, this is no guarantee that interference will not occur in a particular installation. If the Model 2135 does cause interference to radio or television reception, which can be determined by disconnecting the unit, the user is encouraged to try to correct the interference by one or more of the following measures: moving the computing equipment away from the receiver, re-orienting the receiving antenna and/or plugging the receiving equipment into a different AC outlet (such that the computing equipment and receiver are on different branches). In the event the user detects intermittent or continuous product malfunction due to nearby high power transmitting radio frequency equipment, the user is strongly advised to use only a shielded twisted pair data cable that is bonded to metalized external outer shield plugs at both ends. The use of a shielded cable satisfies compliance with the Electromagnetic Compatibility (EMC) directive.

1.2 CE NOTICE

The CE symbol on your Patton Electronics equipment indicates that it is in compliance with the Electromagnetic Compatibility (EMC) directive and the Low Voltage Directive (LVD) of the Union European (EU). A Certificate of Compliance is available by contacting Patton Technical Support.

1.3 SERVICE

All warranty and non-warranty repairs must be returned freight prepaid and insured to Patton Electronics. All returns must have a Return Materials Authorization (RMA) number on the outside of the shipping container. This number may be obtained from Patton Electronics Technical Support at:

Tel: (301) 975-1007
Email: <http://www.patton.com>
www: support@patton.com.

NOTE: Packages received without an RMA number will not be accepted.

Patton Electronics' technical staff is also available to answer any questions that might arise concerning the installation or use of your Model 2135. Technical Support hours: 8AM to 5PM EST, Monday through Friday.

WARNING!  This device is not intended to be connected to the public telephone network.

2.0 GENERAL INFORMATION

Thank you for your purchase of this Patton Electronics product. This product has been thoroughly inspected and tested and is warranted for One Year parts and labor. If any questions or problems arise during installation or use of this product, please do not hesitate to contact Patton Electronics Technical Support at (301) 975-1007.

2.1 FEATURES

- Integral V.35 Male to 10BaseT Ethernet
- Industry standard, shielded RJ-45 10BaseT connection
- 802.3 Ethernet supported by Transparent LAN bridging
- PPP Bridging Control Protocol (RFC 1638) with auto detection for compatibility with existing Patton Bridge Modules
- 4096 MAC address table
- 512 KB RAM; 128KB FLASH expandable to 512 KB
- Throughput latency of 1 frame
- Automatic LAN MAC address aging
- Nine LEDs monitor power, LAN, and DTE Interface signals

2.2 DESCRIPTION

The Patton Model 2135 MicroBridge is an Ethernet Bridge that provides LAN extension when used in conjunction with a V.35 DCE device, such as a DSU/CSU, NTU, or router. The Model 2135 performs transparent Ethernet bridging and functions at the MAC level, thus is transparent to higher level protocols such as TCP/IP, DECnet, NET-BIOS, and IPX network protocols. Only broadcast, multicast, or frames set up for peered LAN are forwarded. The Model 2135 is 802.3 Ethernet compliant and supports PPP Bridging Control Protocol (RFC 1638) on the DTE side.

3.0 PPP OPERATIONAL BACKGROUND

PPP is a protocol used for multi-plexed transport over a point-to-point link. PPP operates on all full duplex media, and is a symmetric peer-to-peer protocol, which can be broken into three main components: 1. A standard method to encapsulate datagrams over serial links; 2. A Link Control Protocol (LCP) to establish, configure, and test the data-link connection; 3. A family of Network Control Protocols (NCPs) to establish and configure different network layer protocols.

In order to establish communications over a point-to-point link, each end of the PPP link must first announce its capabilities and agree on the parameters of the link's operation. This exchange is facilitated through LCP Configure-Request packets.

Once the link has been established and optional facilities have been negotiated, PPP will attempt to establish a network protocol. PPP will use Network Control Protocol (NCP) to choose and configure one or more network layer protocols. Once each of the network layer protocols have been configured, datagrams from the established network layer protocol can be sent over the link. The link will remain configured for these communications until explicit LCP or NCP packets close the link down, or until some external event occurs.

The PPP Bridging Control Protocol (BCP), defined in RFC 1638, configures and enables/disables the bridge protocol on both ends of the point-to-point link. BCP uses the same packet exchange mechanism as the Link Control Protocol (LCP). BCP is a Network Control Protocol of PPP, bridge packets may not be exchanged until PPP has reached the network layer protocol phase.

3.1 Applications

In situations where a routed network requires connectivity to a remote Ethernet network, the interface on a router can be configured as a PPP IP Half Bridge. The serial line to the remote bridge functions as a Virtual Ethernet interface, effectively extending the routers serial port connection to the remote network. The bridge device sends bridge packets (BPDU's) to the router's serial interface. The router will receive the layer three address information and will forward these packets based on its IP address.

Figure 1 shows a typical Cisco router with a serial interface configured as a PPP Half Bridge. The router serial interface uses a remote device that supports PPP bridging to function as a node on the remote Ethernet network. The serial interface on the Cisco will have an IP address on the same Ethernet subnet as the bridge.

For example, the customer site is assigned the addresses 192.168.1.0/24 through 192.168.1.1/24. The address 192.168.1.1/24 is also the default gateway for the remote network. The above settings remove any routing/forwarding intelligence from the CPE. The associ-

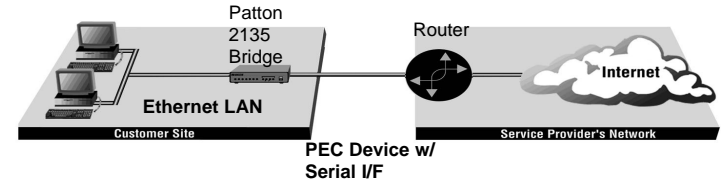

Figure 1. Cisco router with serial interface, configured as PPP Half Bridge.

ated Cisco configuration will set serial interface (s0) to accommodate half bridging for the above example.

Authentication is optional under PPP. In a point-to-point leased-line link, incoming customer facilities are usually fixed in nature, therefore authentication is generally not required. If the foreign device requires authentication via PAP or CHAP, the PPP software will respond with default Peer-ID consisting of the units Ethernet MAC address and a password which consists of the unit's Ethernet MAC address.

Some networking systems do not define network numbers in packets sent out over a network. If a packet does not have a specific destination network number, a router will assume that the packet is set up for the local segment and will not forward it to any other sub-network. However, in cases where two devices need to communicate over the wide-area, bridging can be used to transport non-routable protocols.

Figure 2 illustrates transparent bridging between two routers over a serial interface (s0). Bridging will occur between the two Ethernet Interfaces on Router A (e0 and e1) and the two Ethernet Interfaces on Router B (e0 and e1).

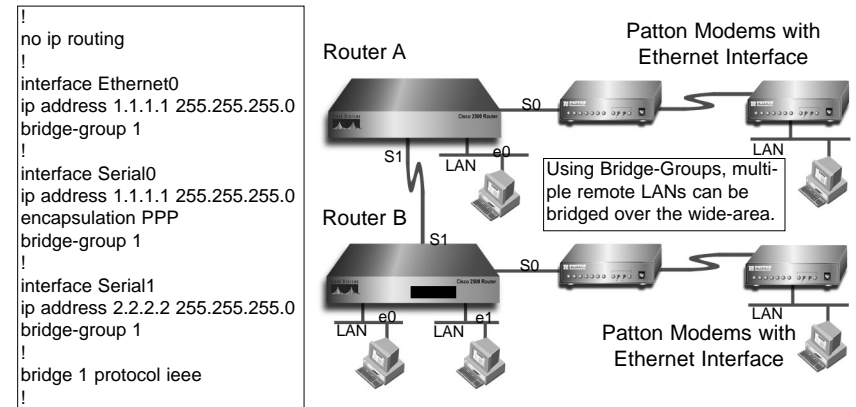

Figure 2. Transparent bridging between two routers over a serial link.

4.0 INSTALLATION

The 2135 is equipped with DTE, Network, and power interfaces. This section briefly describes connection to each interface.

4.1 CONNECT TO 10BASET ETHERNET PORT

The shielded RJ-45 Ethernet port on the Model 2135 is designed to connect directly to a 10BaseT network. Figure 3 shows the 10BaseT RJ-45 port pin description. You may make connections up to 3 feet using type 4 or 5 cable.

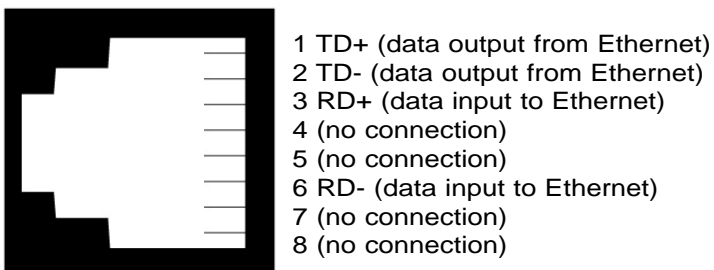
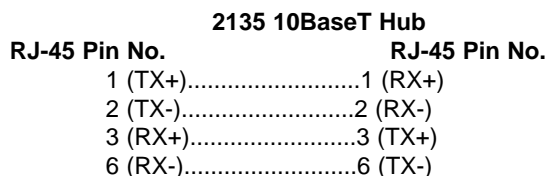

Figure 3. Model 2135 Ethernet connector pinout

4.1.1 Connect the 10BaseT Ethernet Port to a Hub

The Model 2135 10BaseT interface is configured as DTE (Data Terminal Equipment). Use the diagram below to construct a cable to connect the 2135 to a 10BaseT Hub.



4.1.2 Connect the 10BaseT Ethernet Port to a PC (DTE)

The Model 2135 10BaseT interface is configured as DTE (Data Terminal Equipment). To connect the 2135 to another DTE such as a 10BaseT network interface card in a PC, construct a 10BaseT crossover cable as shown in the diagram on the following page.

2135 10BaseT DTE

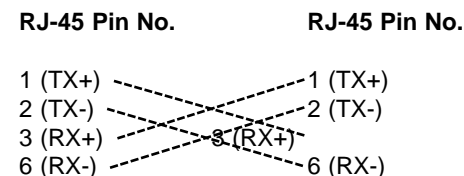

4.2 CONNECT TO THE DTE INTERFACE

The DTE interface is a V.35 DTE (M/34 male connector), designed to plug directly into a DCE interface (See Appendix C V.35 Interface Pin Assignments).

4.3 POWER CONNECTION

The Model 2135 offers either an AC or DC power supply.

4.3.1 AC Power Supply (100-240VAC)

The Model 2135 uses a 5VDC, 2A universal input 100-240VAC, power supply (center pin is +5V). The universal input power supply is equipped with a male IEC-320 connector. This power supply connects to the Model 2135 via a barrel jack on the rear panel. A variety of international power cords are available for the universal power supply.

The Model 2135 powers up as soon as it is plugged into an AC outlet. The unit does not have a power switch.

4.3.2 DC Power

The 36-60 VDC DC to DC adapter is supplied with the DC version of the Model 2135. The black and red leads plug into a DC source (nominal 48VDC) and the barrel power connector plugs into the barrel power supply jack on the 2135.



5.0 CONFIGURATION

All configuration is done through software auto-detection for the Model 2135. Once you have configured your mux or other equipment to be connected to the 2135, the unit is ready for operation. Observe that the serial port of the 2135 is configured as a DTE and must connect to a DCE.

The LAN port also requires no configuration to connect to a 10BaseT Ethernet.

Note: The V.35 Interface is configured as a DTE. The 2135 will transmit and receive data to and from the DCE, based on the speed of the clocks received from the DCE. On the LAN side interface, data is sent and received in burst mode at 10Mbps.

5.1 LED STATUS MONITORS

The 2135 uses two LEDs on the Ethernet connection side. A green LED indicates that link connection to the network is established. The yellow LED displays status codes (See section 5.1.2 for status code information).

Seven, low power, LEDs located on the top of the 2135 case indicate POWER and V.35 signal activity.

5.1.1 LAN side LEDs

The Model 2135 features two LAN LEDs that monitor general operation status and the 10BaseT twisted pair link integrity. Figure 4 shows the LEDs located at the rear of the Model 2135. Following Figure 4 is a description of each LED function. Figure 5 shows the LEDs located on the top of the Model 2135.

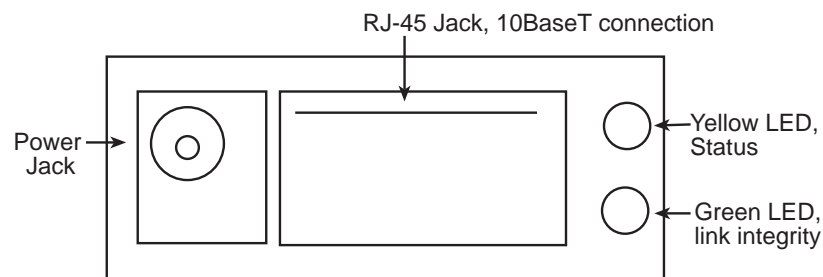

Figure 4. 2135 rear view

5.1.2 LED Descriptions

The status LED blinks yellow from one to eleven times to indicate system status. Each pulse pattern is separated by a 2 second "off" period. Greater pulse patterns have higher priority (buffer saturation has greater priority than an empty MAC table).

Valid system statuses are:

- 1 pulse = system status ok
- 2 pulses = No MAC entries in the MAC address table
- 3 pulses = Clear to send (CTS) or Carrier Detect (DCD) from base unit are not asserted
- 4 pulses = IMRC2/IA buffer is saturated
- 5 pulses = WAN receive frame(s) too large
- 6 pulses = WAN receive frame(s) not Octet aligned
- 7 pulses = WAN receive frame(s) aborted
- 8 pulses = Detected WAN receive frame(s) with bad CRC
- 9 pulses = Detected LAN receive frame(s) too large
- 10 pulses = Detected LAN receive frame(s) not Octet aligned
- 11 pulses = Detected LAN receive frame(s) with bad CRC

After a status code is displayed eight times and the associated condition is removed, the status code will no longer appear.

The link LED glows green to indicate link integrity on the 10BaseT twisted pair line.

5.1.3 Power and DCE/DTE Interface LEDs

Seven LEDs indicate POWER and DTE/DCE activity on the front of the 2135.

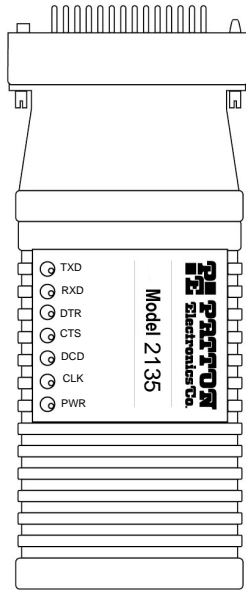

Figure 5. Front of Model 2135, showing LED Indicators

TXD- Transmit data LED (green) blinks to indicate data transitions and remains OFF when no data is transmitted (idle).

RXD- Received data LED (green) blinks to indicate data transitions and remains OFF when no data is received (idle).

DTR- Data Terminal Ready LED (yellow)- turns ON at power up to indicate to the DCE that the 2135 is active.

CTS- Clear to Send LED (yellow) - turns ON when the 2135 is ready to receive data from the DCE.

DCD- Data Carrier Detect LED (yellow) - Turns ON to indicate that a carrier detect signal is received from the DCE.

CLK- Clock Signal LED (yellow) - blinks to indicate that the transmit clock from the DCE is active. The CLK LED will remain OFF to indicate the absence of the transmit clock.

PWR- LED (green) turns ON as soon as power is applied to the 2135.

APPENDIX A

PATTON ELECTRONICS MODEL 2135 SPECIFICATIONS

LAN Connection:	RJ-45, 10BaseT, 802.3 Ethernet supported by Transparent LAN bridging
DTE connection:	M34 connector, V.35 (DTE orientation).
Protocol:	PPP (RFC 1661) with Bridging Control Protocol (RFC 1638)
MAC Address Table Size:	4096 entries
MAC Address Aging:	MAC addresses deleted after eight minutes inactivity
On-board Memory:	512 KB RAM; 128 KB FLASH
Frame Latency:	1 frame
LEDs LAN Side:	(1) yellow, general status; (1) green, link integrity
LEDs DTE Side:	TD, RD and Power, (green); DTR, CTS and CLK, (Yellow)
Power supply Input:	100-240VAC, 50-60Hz, 0.4A
Power Consumption:	500mA @ 5VDC.
Humidity:	Up to 90% non-condensing
Temperature:	0 -50 C
Dimensions:	9.0 x 5.3 x 2.0 cm (3.5"L x 2.1"W x 0.78"H)
Compliance:	FCC Part 15A CE Mark per EEC Directive 89/336/EEC Low Voltage Directive 73/23/EEC

APPENDIX B

2135 FACTORY REPLACEMENT PARTS

Part #	Description
07M2135.....	2135 User Manual
0805DCUI.....	100-250 VAC Universal Power Supply

APPENDIX C

10BaseT Interface Pin Assignment (RJ-45 Female Connector) (DTE Configuration)

Pin #	Signal
1 TD +	(data output from 2135)
2 TD -	(data output from 2135)
3 RD +	(data input to 2135)
4	no connection
5	no connection
6 RD -	(data input to 2135)
7	no connection
8	no connection

APPENDIX D

Terminal Interface Pin Assignment (M/34 Male Connector)

Pin #	Signal
A GND	(Earth Ground/Shield)
B SGND	(Signal Ground)
D CTS	(DCE Source)
E DSR	(DCE Source, Always On)
F CD	(DCE Source)
H (DTR)	(DTE Source)
P TD	(Transmit Data +, DTE Source)
R RD	(Receive Data +, DCE Source)
S TD/	(Transmit Data -, DTE Source)
T RD/	(Receive Data -, DCE Source)
V RC	(Receiver Clock +, DCE Source)
X RC/	(Receiver Clock -, DCE Source)
Y TC	(Transmitter Clock +, DCE Source)
AA TC/	(Transmitter Clock -, DCE Source)

APPENDIX E

POWER SUPPLY INTERFACE

Via 5VDC power jack (J1)
Center Pin: +5VDC @ 500 mA minimum
Outer Barrel: Ground

