

# NETOPIA™ 4541 AND 4542 ADSL ROUTERS

---

User's Reference Guide

netopia.

## **Copyright**

©2001 Netopia, Inc., v.080102  
All rights reserved. Printed in the U.S.A.

This manual and any associated artwork, software, and product designs are copyrighted with all rights reserved. Under the copyright laws such materials may not be copied, in whole or part, without the prior written consent of Netopia, Inc. Under the law, copying includes translation to another language or format.

Netopia, Inc.  
2470 Mariner Square Loop  
Alameda, CA 94501-1010  
U.S.A.

## **Part Number**

For additional copies of this electronic manual, order Netopia part number 6161090-PF-02.

## **Printed Copies**

For printed copies of this manual, order Netopia part number TER/Doc  
(P/N 6161090-00-02).

<b>Chapter 1 — Introduction.....</b>	<b>1-1</b>
Overview .....	1-1
Features and capabilities .....	1-1
How to use this guide .....	1-2
<b>Chapter 2 — Making the Physical Connections.....</b>	<b>2-1</b>
Find a location.....	2-1
What you need .....	2-1
Identify the connectors and attach the cables .....	2-2
Netopia 4541/4542 ADSL Router status lights.....	2-3
<b>Chapter 3 — Sharing the Connection.....</b>	<b>3-1</b>
Configuring TCP/IP on Windows-based Computers .....	3-1
Dynamic configuration (recommended).....	3-2
Static configuration (optional).....	3-3
Configuring TCP/IP on Macintosh Computers .....	3-5
Dynamic configuration (recommended).....	3-5
Static configuration (optional).....	3-6
<b>Chapter 4 — Connecting to Your Local Area Network .....</b>	<b>4-1</b>
Readying computers on your local network.....	4-1
Connecting to an Ethernet network.....	4-2
<b>Chapter 5 — Console-Based Management .....</b>	<b>5-1</b>
Connecting through a Telnet session.....	5-2
Configuring Telnet software .....	5-3
Connecting a console cable to your router .....	5-3
Navigating through the console screens .....	5-4
<b>Chapter 6 — Easy Setup .....</b>	<b>6-1</b>
Easy Setup console screens.....	6-1
Accessing the Easy Setup console screens .....	6-1
Quick Easy Setup connection path .....	6-2
DSL Line Configuration .....	6-3
Easy Setup Profile .....	6-4

IP Easy Setup .....	6-5
Easy Setup Security Configuration .....	6-7
<b>Chapter 7 — WAN and System Configuration .....</b>	<b>7-1</b>
WAN configuration.....	7-1
Creating a new Connection Profile .....	7-4
The default profile.....	7-7
IP parameters (default profile) screen .....	7-8
Scheduled connections .....	7-8
Viewing scheduled connections .....	7-9
Adding a scheduled connection .....	7-10
Set Weekly Schedule .....	7-11
Set Once-Only Schedule.....	7-12
Modifying a scheduled connection .....	7-13
Deleting a scheduled connection .....	7-13
System configuration screens .....	7-13
Navigating through the system configuration screens.....	7-14
System configuration features.....	7-15
IP setup.....	7-16
Filter sets (firewalls) .....	7-16
IP address serving .....	7-16
Date and time.....	7-16
Console configuration.....	7-17
SNMP (Simple Network Management Protocol) .....	7-17
Security.....	7-18
Upgrade feature set .....	7-18
Logging .....	7-18
Installing the Syslog client .....	7-19
<b>Chapter 8 — IP Setup .....</b>	<b>8-1</b>
IP Setup.....	8-2
IP subnets .....	8-4
Static routes.....	8-6
IP Address Serving .....	8-10

IP Address Pools .....	8-13
DHCP NetBIOS Options.....	8-15
More Address Serving Options.....	8-17
Configuring the IP Address Server options.....	8-18
DHCP Relay Agent.....	8-23
Connection Profiles .....	8-25
<b>Chapter 9 — Multiple Network Address Translation .....</b>	<b>9-1</b>
Overview .....	9-1
Features.....	9-1
Supported traffic.....	9-5
MultiNAT Configuration .....	9-5
Easy Setup Profile configuration .....	9-6
Server Lists and Dynamic NAT configuration .....	9-6
IP setup.....	9-7
Modifying map lists .....	9-12
Adding Server Lists.....	9-14
Modifying server lists .....	9-17
Deleting a server .....	9-19
Binding Map Lists and Server Lists .....	9-20
IP profile parameters .....	9-20
IP Parameters (WAN Default Profile).....	9-22
NAT Associations .....	9-24
MultiNAT Configuration Example .....	9-26
<b>Chapter 10 — Virtual Private Networks (VPNs).....</b>	<b>10-1</b>
Overview .....	10-1
About PPTP Tunnels .....	10-3
PPTP configuration.....	10-4
About IPsec Tunnels.....	10-7
Configuration .....	10-7
IP Profile Parameters .....	10-10
Advanced IP Profile Options.....	10-11
Interoperation with other features.....	10-12

About ATMP Tunnels.....	10-12
ATMP configuration.....	10-12
Encryption Support .....	10-15
MS-CHAP V2 and 128-bit strong encryption.....	10-15
ATMP/PPTP Default Profile.....	10-16
VPN QuickView .....	10-17
Dial-Up Networking for VPN.....	10-18
Installing Dial-Up Networking.....	10-18
Creating a new Dial-Up Networking profile .....	10-19
Configuring a Dial-Up Networking profile .....	10-20
Installing the VPN Client.....	10-21
Windows 95 VPN installation.....	10-21
Windows 98 VPN installation.....	10-22
Connecting using Dial-Up Networking .....	10-23
Allowing VPNs through a Firewall.....	10-23
PPTP example .....	10-24
ATMP example .....	10-26
<b>Chapter 11 — Security .....</b>	<b>11-1</b>
Suggested security measures.....	11-1
User accounts .....	11-1
Telnet access .....	11-3
About filters and filter sets .....	11-4
What's a filter and what's a filter set?.....	11-4
How filter sets work.....	11-4
How individual filters work.....	11-6
Design guidelines.....	11-11
Working with IP filters and filter sets.....	11-12
Adding a filter set.....	11-12
Deleting a filter set.....	11-17
A sample filter set.....	11-17
Firewall tutorial .....	11-20
General firewall terms .....	11-20

Basic IP packet components .....	11-21
Basic protocol types .....	11-21
Firewall design rules .....	11-22
Filter basics .....	11-24
Example filters .....	11-25
<b>Chapter 12 — Monitoring Tools .....</b>	<b>12-1</b>
Quick View status overview .....	12-1
General status .....	12-2
Current status .....	12-3
Status lights .....	12-3
Statistics & Logs .....	12-4
Event histories .....	12-4
IP Routing Table .....	12-7
General Statistics .....	12-7
System Information .....	12-9
SNMP .....	12-9
The SNMP Setup screen .....	12-10
SNMP traps .....	12-11
<b>Chapter 13 — Utilities and Diagnostics .....</b>	<b>13-1</b>
Ping .....	13-2
Trace Route .....	13-4
Telnet client .....	13-5
Factory defaults .....	13-6
Transferring configuration and firmware files with TFTP ...	13-7
Updating firmware .....	13-7
Downloading configuration files .....	13-8
Uploading configuration files .....	13-9
Transferring configuration and firmware files with XMODEM .....	13-9
Updating firmware .....	13-10
Downloading configuration files .....	13-11
Uploading configuration files .....	13-11

Restarting the system.....	13-12
<b>Appendix A — Troubleshooting.....</b>	<b>A-1</b>
Configuration problems .....	A-1
Console connection problems .....	A-2
Network problems .....	A-2
How to reset the router to factory defaults .....	A-3
Power outages.....	A-3
Technical support .....	A-4
How to reach us.....	A-4
<b>Appendix B — Technical Specifications and Safety Information ..</b>	<b>B-1</b>
Description.....	B-1
Power requirements .....	B-1
Environment .....	B-1
Software and protocols.....	B-1
Agency approvals.....	B-1
Regulatory notices .....	B-2
Important safety instructions .....	B-4
<b>Limited Warranty and Limitation of Remedies-Revised January 2002</b>	



# Chapter 1

## Introduction

---

### Overview

The Netopia 4541/4542 ADSL Router is a full-featured, stand-alone DSL router for connecting diverse local area networks (LANs) to the Internet and other remote networks. The Netopia 4541/4542 ADSL Router uses a high performance telecommunications line to provide your whole network with a high-speed connection to the outside world. Model 4541 is designed for North American users; model 4542 is designed for non-North American users. Both support the same features.

This section covers the following topics:

- [“Features and capabilities” on page 1-1](#)
- [“How to use this guide” on page 1-2](#)

---

### Features and capabilities

The Netopia 4541/4542 ADSL Router provides the following features:

- Support for IP routing for Internet and Intranet connectivity
- ADSL WAN interface supports symmetric data rates from 144 kbps to 2.32 Mbps
- Built-in VPN features offer secure Internet connections between remote offices and travelers
- Built-in firewall protects LAN resources from Internet intruders
- Support for Ethernet LANs with multiple Ethernet IP subnets
- 10/100-Base T Ethernet port connects easily to an existing LAN hub
- Interoperable with a wide array of DSLAM equipment
- Console-based Telnet client
- UNIX syslog client
- Status lights (LEDs) for easy monitoring and troubleshooting
- Support for Console-based management
- NAT/NATP, multi-NAT, and DHCP for security and convenience
- Wall-mountable, Bookshelf (Side-stackable), or Desktop-stackable design for efficient space usage

## *How to use this guide*

In addition to the simple documentation contained in the accompanying *Getting Started Guide*, this guide is designed to be your single source for information about your Netopia 4541/4542 ADSL Router. It is intended to be viewed on-line, using the powerful features of the Adobe Acrobat Reader. The information display has been deliberately designed to present the maximum information in the minimum space on your screen. You can keep this document open while you perform any of the procedures described, and find useful information about the procedure you are performing.

You can also print out all of the manual, or individual sections, if you prefer to work from hard copy rather than on-line documentation. The pages are formatted to print on standard 8 1/2 by 11 inch paper. We recommend that you print on 3-hole punched paper, so that you can put the pages in a binder for future reference. For your convenience, a printed copy is available from Netopia. Order part number TE4541/Doc.

This guide is organized into chapters describing the Netopia 4541/4542's advanced features. You may want to read each chapter's introductory section to familiarize yourself with the various features available.

Use the guide's table of contents and index to locate informational topics.

## Chapter 2

# Making the Physical Connections

This section tells you how to make the physical connections to your Netopia 4541/4542 ADSL Router. This section covers the following topics:

- “Find a location” on page 2-1
- “What you need” on page 2-1
- “Identify the connectors and attach the cables” on page 2-2
- “Netopia 4541/4542 ADSL Router status lights” on page 2-3

---

### Find a location

When choosing a location for the Netopia ADSL Router, consider:

- Available space and ease of installation
- Physical layout of the building and how to best use the physical space available for connecting your Netopia ADSL Router to the LAN
- Available wiring and jacks
- Distance from the point of installation to the next device (length of cable or wall wiring)
- Ease of access to the front of the unit for configuration and monitoring
- Ease of access to the back of the unit for checking and changing cables
- Cable length and network size limitations when expanding networks

For small networks, install the Netopia 4541/4542 near one of the LANs. For large networks, you can install the Netopia 4541/4542 in a wiring closet or a central network administration site.

---

### What you need

Locate all items that you need for the installation.

Included in your router package are:

- The Netopia 4541/4542 ADSL Router
- A power adapter and cord with a mini-DIN8 connector
- One Category 5 Ethernet cable
- One Category 5 DSL WAN (or Line) cable
- A DB-9 to DB-9 console cable
- The Netopia CD containing software and documentation

## 2-2 User's Reference Guide

You will need:

- A Windows 95 or 98–based PC or a Macintosh computer with Ethernet connectivity for configuring the Netopia 4541/4542. This may be built-in Ethernet or an add-on card, with TCP/IP installed and configured. See [“Sharing the Connection”](#) on page 3-1.
- An ADSL wall outlet wired for a connection to a Local Exchange Carrier (LEC) who supports Symmetric Digital Subscriber Line connections.

---

### Identify the connectors and attach the cables

Identify the connectors and switches on the back panel and attach the necessary Netopia Router cables.

The figure below displays the back of the Netopia 4541/4542 ADSL Router.

*Netopia 4541/4542 back panel*

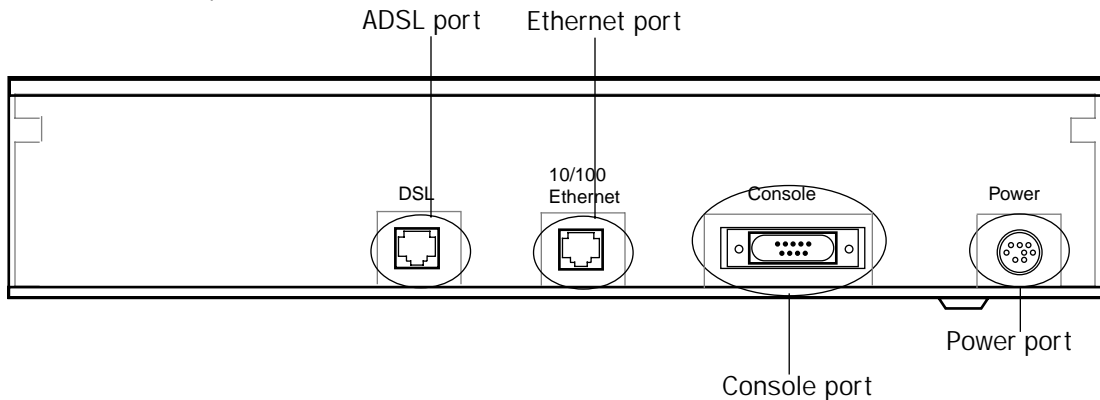

Port	Description
Power port	A mini-DIN8 power adapter cable connection.
Console port	A DB-9 console port for a direct serial connection to the console screens. You can use this if you are an experienced user. See <a href="#">“Connecting a console cable to your router”</a> on page 5-3.
DSL port	An RJ-48 jack labeled DSL for your ADSL connection.
Ethernet port	An RJ-45 10/100Base-T Ethernet jack. You will use this to configure the Netopia 4541/4542. For a new installation, use the Ethernet connection. Alternatively, you can use the console connection to run console-based management using a direct serial connection. You can either connect your computer directly the Ethernet port using a crossover cable, or connect both your computer and the Netopia 4541/4542 to an existing Ethernet hub on your LAN.

1. Connect the mini-DIN8 connector from the power adapter to the power port, and plug the other end into an electrical outlet.
2. Connect one end of the Category 5 cable to the DSL port, and the other end to your DSL wall outlet.

- Connect the Ethernet cable to the Ethernet port on the router and the other end to your computer.  
You should now have: the power adapter plugged in; the Ethernet cable connected between the router and your computer; and the DSL cable connected between the router and the DSL wall outlet.

### Netopia 4541/4542 ADSL Router status lights

The figure below represents the Netopia 4541/4542 status light (LED) panel.

Netopia 4541/4542 LED front panel

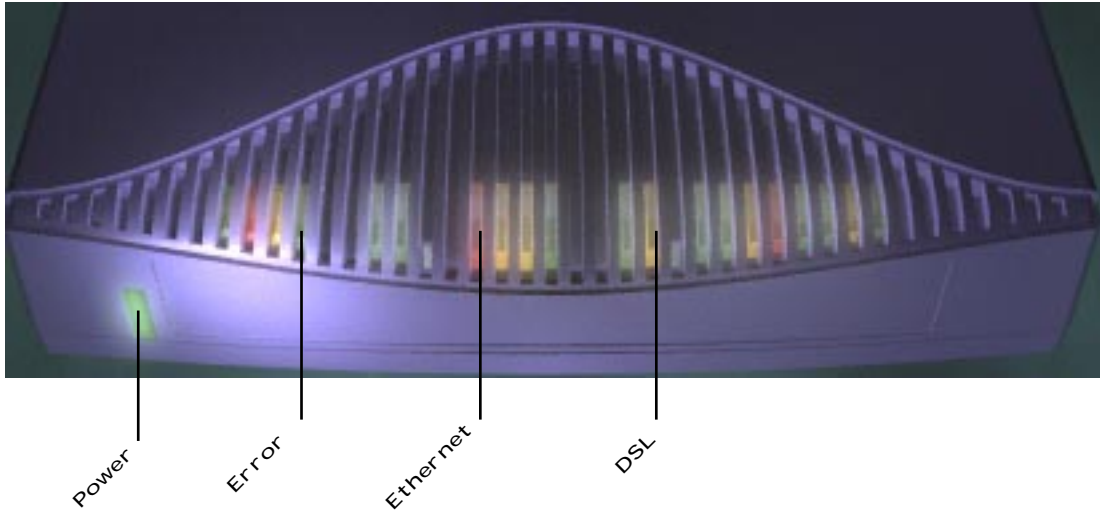

The following table summarizes the meaning of the various LED states and colors:

When this happens...	the LEDs...
The power is on	<b>Power</b> is green.
The Router detects an error	<b>Error</b> is red.
The Ethernet link is established	<b>Ethernet</b> is green.
The WAN has trained	<b>DSL</b> is green.
The WAN is training	<b>DSL</b> flashes green.
<b>Note:</b> The remaining LEDs are not used.	



## Chapter 3

# Sharing the Connection

Once you have set up your physical local area network, you will need to configure the TCP/IP stack on each client workstation connected to your Netopia 4541/4542. This chapter describes how to configure TCP/IP for both Windows-based and Macintosh computers.

This chapter explains the following topics:

- “Configuring TCP/IP on Windows-based Computers” on page 3-1
- “Configuring TCP/IP on Macintosh Computers” on page 3-5

---

### *Configuring TCP/IP on Windows-based Computers*

Configuring TCP/IP on a Windows computer requires the following:

- An Ethernet card (also known as a network adapter)
- The TCP/IP protocol must be “bound” to the adapter or card

## Dynamic configuration (recommended)

To configure your PC for dynamic addressing do the following:

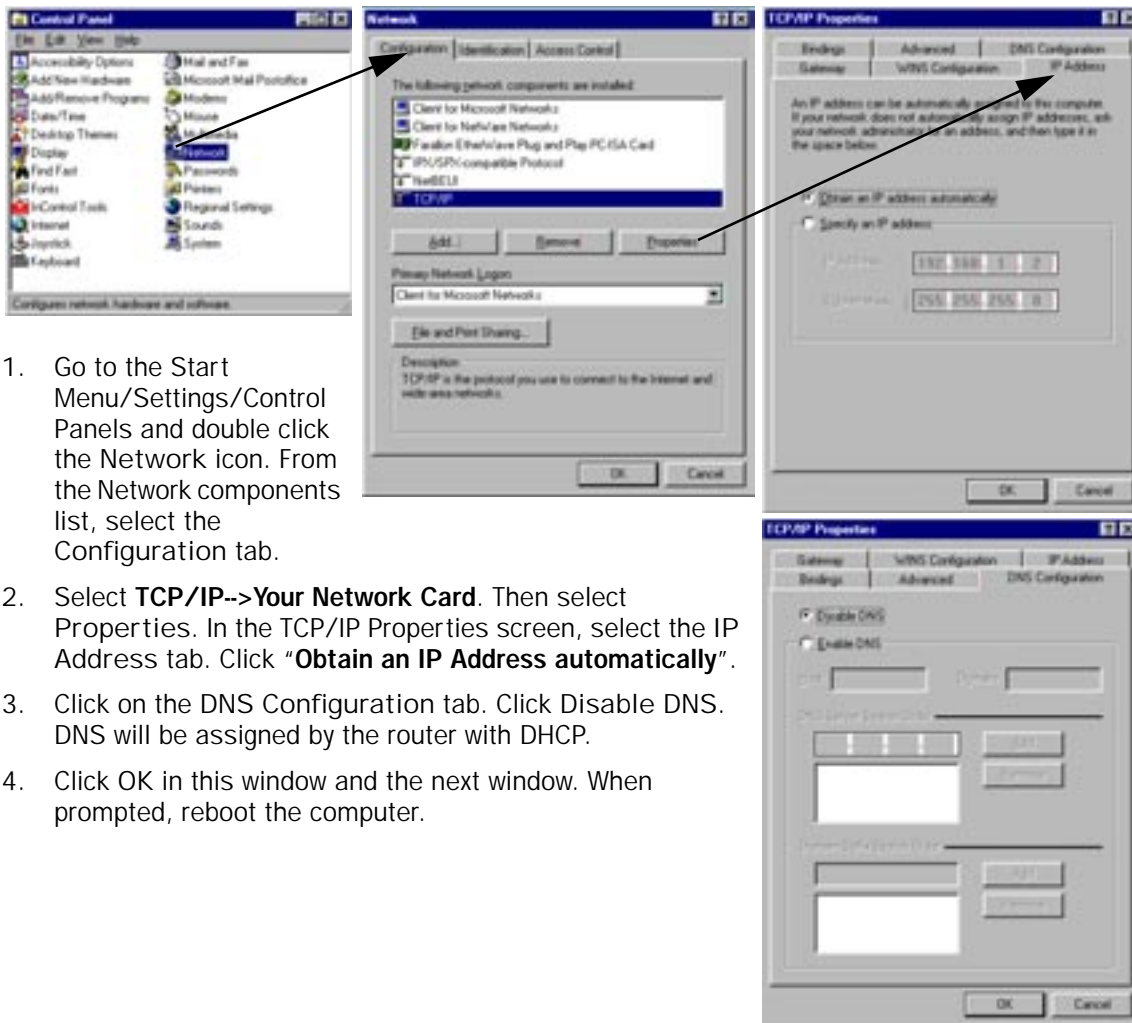

1. Go to the Start Menu/Settings/Control Panels and double click the Network icon. From the Network components list, select the Configuration tab.
2. Select **TCP/IP-->Your Network Card**. Then select Properties. In the TCP/IP Properties screen, select the IP Address tab. Click "**Obtain an IP Address automatically**".
3. Click on the DNS Configuration tab. Click Disable DNS. DNS will be assigned by the router with DHCP.
4. Click OK in this window and the next window. When prompted, reboot the computer.

Note: You can also use these instructions to configure other computers on your network to accept IP addresses served by the Netopia 4541/4542.



## Static configuration (optional)

If you are manually configuring for a fixed or static IP address, perform the following:

1. Go to Start Menu/Settings/Control Panels and double click the Network icon. From the Network components list, select the Configuration tab.
2. Select **TCP/IP-->Your Network Card**. Then select **Properties**. In the TCP/IP Properties screen, select the IP Address tab. Click "**Specify an IP Address.**"

Enter the following:

IP Address: 192.168.1.2

Subnet Mask: 255.255.255.0, or for 12-user models 255.255.255.240

This address is an example of one that can be used to configure the router. Your ISP or network administrator may ask you to use a different IP address and subnet mask.

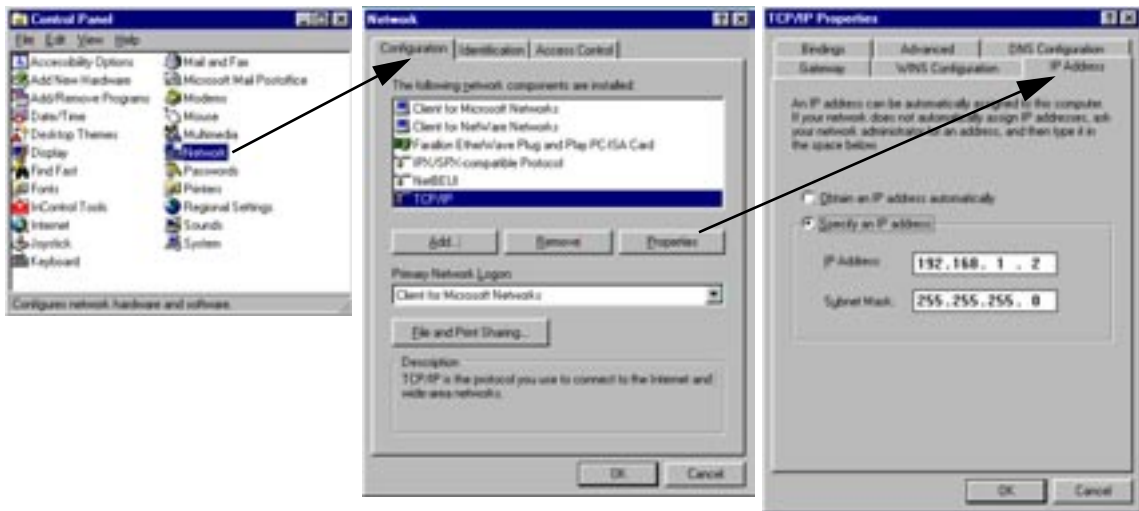

3. Click on the Gateway tab (shown below). Under "New gateway," enter 192.168.1.1. Click Add. This is the Netopia 4541/4542's pre-assigned IP address.



Click on the DNS Configuration tab. Click Enable DNS. Enter the following information:

Host: Type the name you want to give to this computer.

Domain: Type your domain name. If you don't have a domain name, type your ISP's domain name; for example, netopia.com.

DNS Server Search Order: Type the primary DNS IP address given to you by your ISP. Click Add. Repeat this process for the secondary DNS.

Domain Suffix Search Order: Enter the same domain name you entered above.



4. Click OK in this window and the next window. When prompted, reboot the computer.

Note: You can also use these instructions to configure other computers on your network with manual or static IP addresses. Be sure each computer on your network has its own IP address.

## Configuring TCP/IP on Macintosh Computers

The following is a quick guide to configuring TCP/IP for MacOS computers. Configuring TCP/IP in a Macintosh computer requires the following:

- You must have either Open Transport or Classic Networking (MacTCP) installed.

Note: If you want to use the Dynamic Host Configuration Protocol (DHCP) server built into your Netopia 4541/4542 to assign IP addresses to your Macintoshes, you must be running Open Transport, standard in MacOS 8 and optional in earlier system versions. You can have your Netopia 4541/4542 dynamically assign IP addresses using MacTCP; however, to do so requires that the optional AppleTalk kit be installed which can only be done after the router is configured.

- You must have built-in Ethernet or a third-party Ethernet card and its associated drivers installed in your Macintosh.

### Dynamic configuration (recommended)

The Dynamic Host Configuration Protocol (DHCP), which enables dynamic addressing, is enabled by default in the router. To configure your Macintosh computer for dynamic addressing do the following:

1. Go to the Apple menu. Select Control Panels and then TCP/IP.
2. With the TCP/IP window open, go to the Edit menu and select User Mode. Choose Basic and click OK.
3. In the TCP/IP window, select **"Connect via: Ethernet"** and **"Configure: Using DHCP Server."**

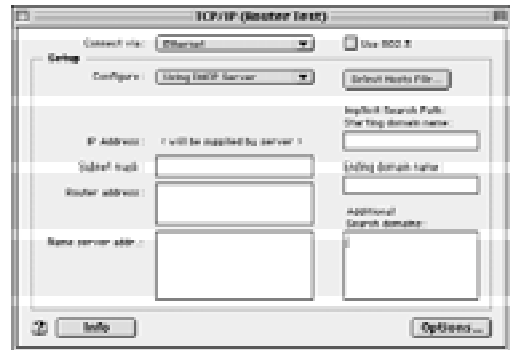

Note: You can also use these instructions to configure other computers on your network to accept IP addresses served by the Netopia 4541/4542.

## Static configuration (optional)

If you are manually configuring for a fixed or static IP address, perform the following:

1. Go to the Apple menu. Select Control Panels and then TCP/IP or MacTCP.
2. With the TCP/IP window open, go to the Edit menu and select User Mode. Choose Advanced and click OK.

Or, in the MacTCP window, select Ethernet and click the More button.

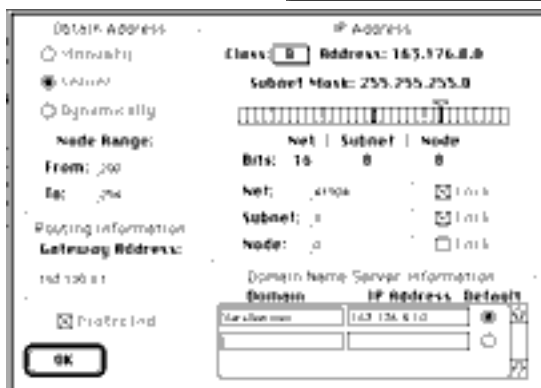
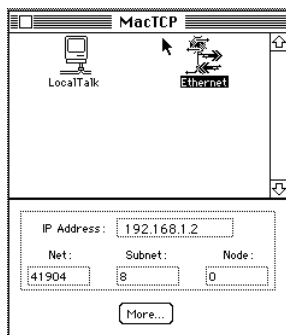
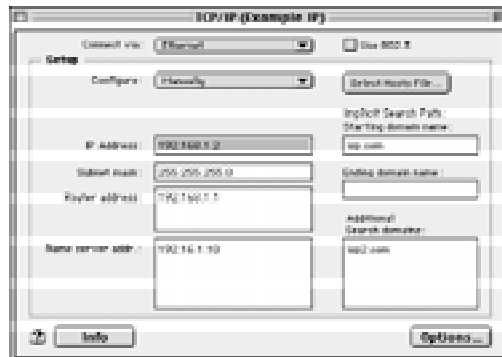

3. In the TCP/IP window or in the MacTCP/More window, select or type information into the fields as shown in the following table.

Option:	Select/Type:
Connect via:	Ethernet
Configure:	Manually
IP Address:	192.168.1.2
Subnet mask:	255.255.255.0, or for 12-user models 255.255.255.240
Router or Gateway address:	192.168.1.1
Name server address:	Enter the primary and secondary name server addresses given to you by your ISP
Implicit Search Path: Starting domain name:	Enter your domain name; if you do not have a domain name, enter the domain name of your ISP

4. Close the TCP/IP or MacTCP control panel and save the settings.
5. If you are using MacTCP, you must restart the computer. If you are using Open Transport, you do not need to restart.

Note: You can also use these instructions to configure other computers on your network to accept IP addresses served by the Netopia 4541/4542.

Note: You can also use these instructions to configure other computers on your network with manual or static IP addresses. Be sure each computer on your network has its own IP address.

More information about configuring your Macintosh computer for TCP/IP connectivity through a Netopia 4541/4542 can be found in Technote NIR\_026, "Open Transport and Netopia Routers," located on the Netopia Web site.



## Chapter 4

# Connecting to Your Local Area Network

This chapter describes how to physically connect the Netopia 4541/4542 to your local area network (LAN). Before you proceed, make sure the Netopia 4541/4542 is properly configured. You can customize the router's configuration for your particular LAN requirements using console-based management (see ["Console-Based Management"](#) on page 5-1).

This section covers the following topics:

- ["Readying computers on your local network"](#) on page 4-1
- ["Connecting to an Ethernet network"](#) on page 4-2

---

### *Readying computers on your local network*

PC and Macintosh computers must have certain components installed before they can communicate through the Netopia 4541/4542. The following illustration shows the minimal requirements for a typical PC or Macintosh computer.

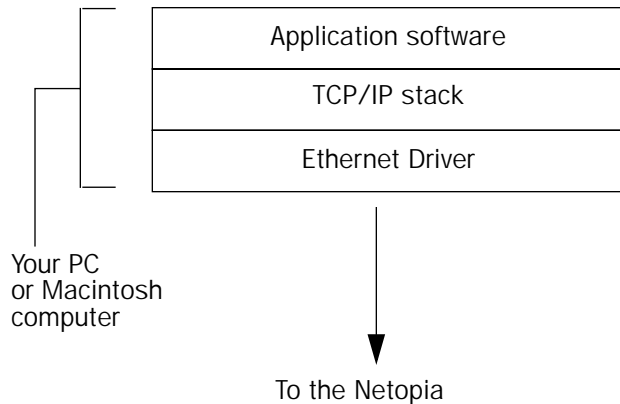

**Application software:** This is the software you use to send e-mail, browse the World Wide Web, read newsgroups, etc. These applications may require some configuration. Examples include the Eudora e-mail client and the Web browsers Microsoft Internet Explorer and Netscape Navigator.

**TCP/IP stack:** This is the software that lets your PC or Macintosh computer communicate using Internet protocols. TCP/IP stacks must be configured with some of the same information you used to configure the Netopia 4541/4542. There are a number of TCP/IP stacks available for PC computers. Windows 95 includes a built-in TCP/IP stack. Macintosh computers use either MacTCP or Open Transport. See ["Configuring TCP/IP on Windows-based Computers"](#) on page 3-1. Macintosh computers use either MacTCP or Open Transport. See ["Configuring TCP/IP on Macintosh Computers"](#) on page 3-5.

**Ethernet:** Ethernet hardware and software drivers enable your PC or Macintosh computer to communicate on the LAN.

## 4-2 User's Reference Guide

Once the Netopia 4541/4542 is properly configured and connected to your LAN, PC and Macintosh computers that have their required components in place will be able to connect to the Internet or other remote IP networks.

---

### Connecting to an Ethernet network

The Netopia 4541/4542 supports Ethernet connections through its Ethernet port. You can connect a standard 10 or 100Base-T Ethernet network to the Netopia 4541/4542 using its Ethernet port.

*Netopia 4541/4542 back panel*

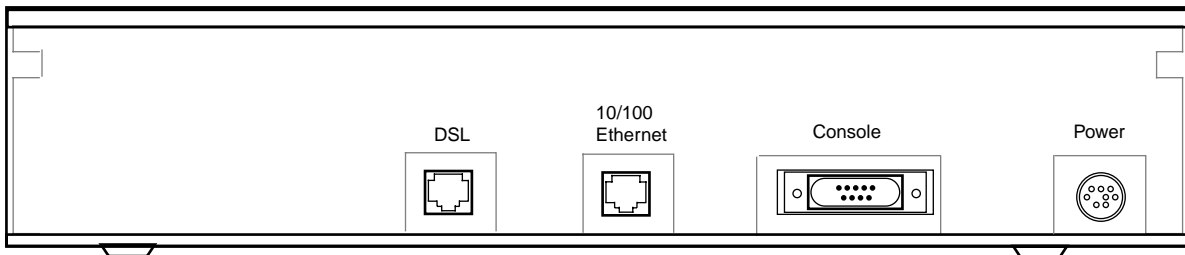

*The Netopia 4541/4542 in a 10Base-T network*

To connect your 10Base-T network to the Netopia 4541/4542 through the Ethernet port, use a 10Base-T cable with RJ-45 connectors.

If you have more than one device to connect, you can attach additional devices using a cross-over cable (not provided) or you can connect through a switch or repeater.

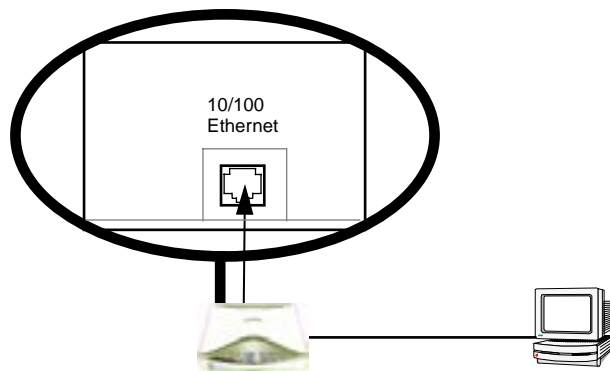



# Chapter 5

## Console-Based Management

Console-based management is a menu-driven interface for the capabilities built into the Netopia 4541/4542. Console-based management provides access to a wide variety of features that the router supports. You can customize these features for your individual setup. This chapter describes how to access the console-based management screens.

This section covers the following topics:

- “Connecting through a Telnet session” on page 5-2
- “Connecting a console cable to your router” on page 5-3
- “Navigating through the console screens” on page 5-4

Console-based management screens contain seven entry points to the Netopia 4541/4542 configuration and monitoring features. The entry points are displayed in the Main Menu shown below:

```
Netopia 4541

Easy Setup...
WAN Configuration...
System Configuration...
Utilities & Diagnostics...
Statistics & Logs...
Quick Menus...
Quick View...

Return/Enter goes to Easy Setup -- minimal configuration.
You always start from this main screen.
```

- The **Easy Setup** menu displays and permit changing the values contained in the default connection profile. You can use Easy Setup to initially configure the router directly through a console session. Easy Setup menus contain up to five descendant screens for viewing or altering these values. The number of screens depends on whether you have optional features installed.
- The **WAN Configuration** menu displays and permits changing your connection profile(s) and default profile, creating or deleting additional connection profiles, and configuring or reconfiguring the manner in which you

may be using the router to connect to more than one service provider or remote site.

- The **System Configuration** menus display and permit changing:
  - IP setup. See ["IP Setup" on page 8-1](#).
  - Filter sets (firewalls). See ["Security" on page 11-1](#).
  - IP address serving. See ["IP Address Serving" on page 8-10](#).
  - Date and time. See ["Date and time" on page 7-16](#).
  - Console configuration. See ["Connecting a console cable to your router" on page 5-3](#).
  - SNMP (Simple Network Management Protocol). See ["SNMP" on page 12-9](#).
  - Security. See ["Security" on page 11-1](#).
  - Upgrade feature set. See ["Upgrade feature set" on page 7-18](#).
- The **Utilities & Diagnostics** menus provide a selection of seven tools for monitoring and diagnosing the router's behavior, as well as for updating the firmware and rebooting the system. See ["Utilities and Diagnostics" on page 13-1](#) for detailed information.
- The **Statistics & Logs** menus display nine sets of tables and device logs that show information about your router, your network, and their history. See ["Statistics & Logs" on page 12-4](#) for detailed information.
- The **Quick Menus** screen is a shortcut entry point to 22 of the most commonly used configuration menus that are accessed through the other menu entry points.
- The **Quick View** menu displays at a glance current real-time operating information about your router. See ["Quick View status overview" on page 12-1](#) for detailed information.

---

## *Connecting through a Telnet session*

Features of the Netopia 4541/4542 can be configured through the console screens.

Before you can access the console screens through Telnet, you must have:

- A network connection locally to the router or IP access to the router.

**Note:** Alternatively, you can have a direct serial console cable connection using the provided console cable for your platform (PC or Macintosh) and the Console port on the back of the router. For more information on attaching the console cable, see ["Connecting a console cable to your router" on page 5-3](#).

- Telnet software installed on the computer you will use to configure the router

## Configuring Telnet software

If you are configuring your router using a Telnet session, your computer must be running a Telnet software program.

- If you connect a PC with Microsoft Windows, you can use a Windows Telnet application or simply run Telnet from the Start menu.
- If you connect a Macintosh computer, you can use the NCSA Telnet program supplied on the Netopia 4541/4542 CD. You install NCSA Telnet by simply dragging the application from the CD to your hard disk.

---

## Connecting a console cable to your router

You can perform all of the system configuration activities for your Netopia 4541/4542 through a local serial console connection using terminal emulation software, such as HyperTerminal provided with Windows 95, 98, 2000, or NT on the PC, or ZTerm, included on the Netopia CD, for Macintosh computers.

The Netopia 4541/4542 back panel has a connector labeled "Console" for attaching the Router to either a PC or Macintosh computer via the serial port on the computer. (On a Macintosh computer, the serial port is called the Modem port or Printer port.) This connection lets you use the computer to configure and monitor the Netopia 4541/4542 via the console screens.

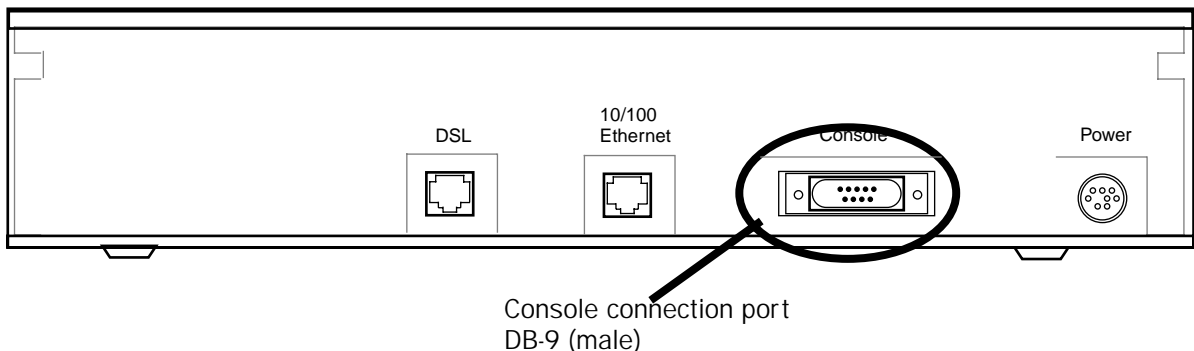

To connect the Netopia 4541/4542 to your computer for serial console communication, use a console cable appropriate to your platform:

- A DB-9 connector end attaches to a PC.
- A mini-DIN8 connector end attaches to a Macintosh computer depending on your computer's serial bus type. Since Macintosh computers have different serial bus connectors, you will need a mini-DIN8-to-DB-9 adapter. These are available from a variety of third-party manufacturers.
- A DB-9 end of the Console cable attaches to the Netopia 4541/4542's Console port.
- If you connect a PC with Microsoft Windows 95, 98, 2000, or NT, you can use the HyperTerminal application bundled with the operating system.
- If you connect a Macintosh computer, you can use the ZTerm terminal emulation program on the supplied Netopia 4541/4542 CD.

## 5-4 User's Reference Guide

Launch your terminal emulation software and configure the communications software for the values shown in the table below. These are the default communication parameters that the Netopia 4541/4542 uses.

Parameter	Suggested Value
Terminal type	<b>PC:</b> ANSI-BBS <b>Mac:</b> ANSI, VT-100, or VT-200
Data bits	8
Parity	None
Stop bits	1
Speed	9600 - 57600 bits per second
Flow Control	None
<b>Note:</b> The router firmware contains an autobaud detection feature. If you are at any screen on the serial console, you can change your baud rate and press Return (HyperTerminal for the PC requires a disconnect). The new baud rate is displayed at the bottom of the screen.	

---

### *Navigating through the console screens*

Use your keyboard to navigate the Netopia 4541/4542's configuration screens, enter and edit information, and make choices. The following table lists the keys to use to navigate through the console screens.

To...	Use These Keys...
Move through selectable items in a screen or pop-up menu	Up, Down, Left, and Right Arrow
Set a change to a selected item or open a pop-up menu of options for a selected item like entering an upgrade key	Return or Enter
Change a toggle value (Yes/No, On/Off)	Tab
Restore an entry or toggle value to its previous value	Esc
Move one item up	Up arrow or Control + K
Move one item down	Down arrow or Control + O
Display a dump of the device event log	Control + E
Display a dump of the WAN event log	Control + F
Refresh the screen	Control + L

# Chapter 6

## Easy Setup

This chapter describes how to use the Easy Setup console screens on your Netopia 4541/4542. After completing the Easy Setup console screens, your router will be ready to connect to the Internet or another remote site.

---

### *Easy Setup console screens*

Using four Easy Setup console screens, you can:

- Modify a connection profile for your router for the connection to your ISP or remote location
- Set up IP addresses and IP address serving
- Password-protect configuration access to your Netopia 4541/4542

### *Accessing the Easy Setup console screens*

To access the console screens, Telnet to the Netopia Router over your Ethernet network or physically connect with a serial console cable and access the Netopia Router with a terminal emulation program. See [“Connecting through a Telnet session” on page 5-2](#) or [“Connecting a console cable to your router” on page 5-3](#).

**Note:** Before continuing, make sure you have the information that your ISP or network administrator has given you for configuring the Netopia Router.

The Netopia Router’s first console screen, Main Menu, appears in the terminal emulation window of the attached PC or Macintosh computer when:

- The Netopia Router is turned on
- The computer is connected to the Netopia Router
- Telnet or the terminal emulation software is running and configured correctly

A screen similar to the following Main Menu appears:

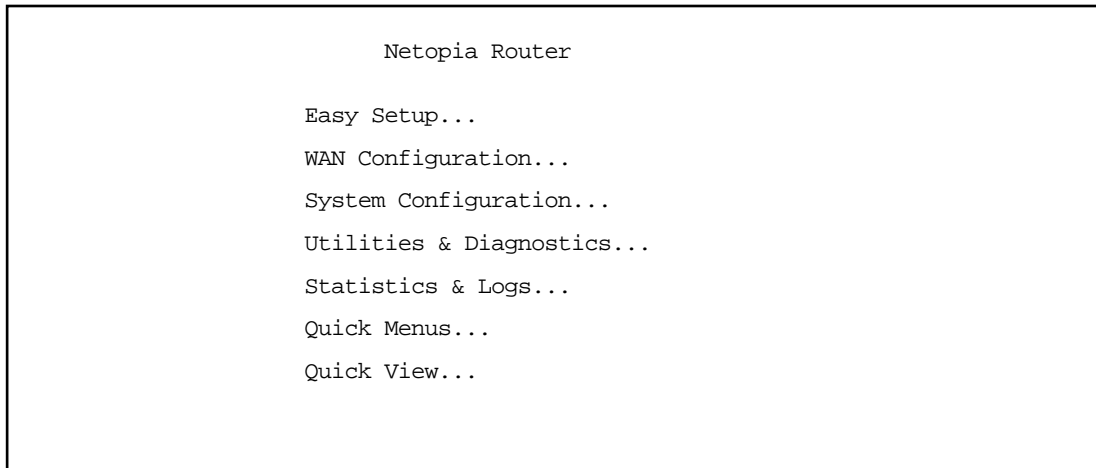

If you do not see the Main Menu, verify that:

- If you are using a serial connection, that your serial port speed is the same as the Netopia 4541/4542's default 9600 baud, for first use.
- The computer used to view the console screen has its serial port connected to the Netopia 4541/4542's Console port or an Ethernet connection to one of its Ethernet ports. See ["Connecting a console cable to your router"](#) on page 5-3 or ["Connecting through a Telnet session"](#) on page 5-2.
- Telnet or the terminal emulation software is configured for the recommended values.
- If you are connecting via the Console port, your computer's serial port is not being used by another device, such as an internal modem, or an application. Turn off all other programs (other than your terminal emulation program) that may be interfering with your access to the port.
- You have entered the correct password, if necessary. Your Netopia 4541/4542's console access may be password protected from a previous configuration. See your system administrator to obtain the password. See [Appendix A, "Troubleshooting,"](#) for more suggestions.

---

### ***Quick Easy Setup connection path***

If your ISP assigns your Router a Static IP address, do the following:

1. Open a Telnet session to 192.168.1.1 to bring up the Main Menu.

If you don't know how to do this, see ["Connecting through a Telnet session"](#) on page 5-2.

Alternatively, you can connect the console cable and open a direct serial console connection, using a terminal emulator program. See ["Connecting a console cable to your router"](#) on page 5-3.

The Main Menu appears.

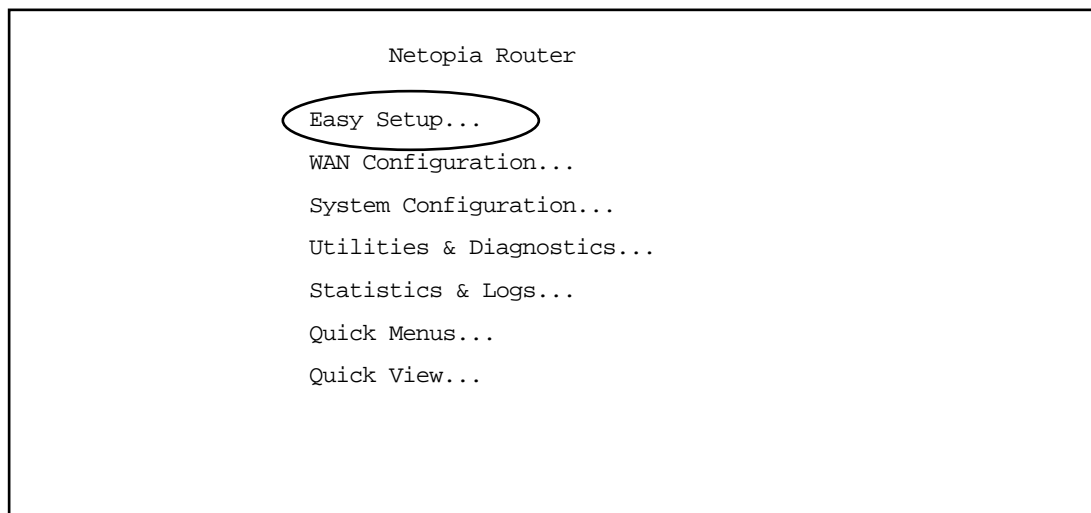

2. Select the first item on the Main Menu list, **Easy Setup**. Press Return to bring up the ADSL Line Configuration menu screen.

## DSL Line Configuration

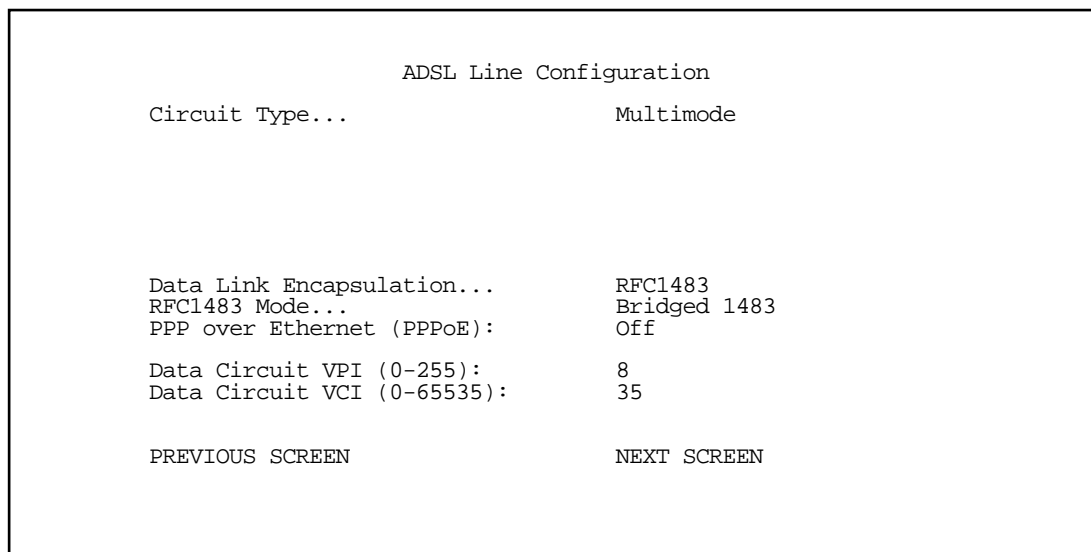

1. Select **Circuit Type** and, from the pop-up menu, choose the type of circuit to which you will be connecting: Multimode, T1.413, G.dmt, G.lite, or ADI.
2. Select **Data Link Encapsulation** and from the pop-up menu choose either RFC1483 (the default) or PPP.
  - If you selected RFC1483, the next pop-up menu **RFC1483 Mode** offers the choice of Bridged 1483 or

## 6-4 User's Reference Guide

Routed 1483. If you select Bridged 1483, a new option **PPP over Ethernet (PPPoE)** appears. You can then toggle PPPoE On or Off. Choosing Routed 1483 hides the PPPoE option.

- If you selected PPP, the next pop-up menu **PPP Mode** offers the choice of VC Multiplexed or LLC SNAP.
3. The next two fields, **Data Circuit VPI** and **Data Circuit VCI** are editable. Enter the Virtual Path Identifier and Virtual Channel Identifier values that your provider specifies.
  4. Press the Down arrow key until you reach **NEXT SCREEN**. Press Return to bring up the next screen.

### Easy Setup Profile

The Easy Setup Profile screen is where you configure the parameters that control the Netopia 4541/4542's connection to a specific remote destination, usually your ISP or a corporate site.

On a Netopia 4541/4542 you can add up to 15 more connection profiles, for a total of 16, although you can only use one at a time, unless you are using Virtual Private Networks (VPNs).

Connection Profile 1: Easy Setup Profile	
Connection Profile Name:	Easy Setup Profile
Address Translation Enabled:	Yes
IP Addressing...	Numbered
Local WAN IP Address:	0.0.0.0
Local WAN IP Mask:	0.0.0.0
Remote IP Address:	0.0.0.0
Remote IP Mask:	0.0.0.0
PPP Authentication...	None
PREVIOUS SCREEN	NEXT SCREEN

**Note:** The appearance of this screen varies, depending on the settings in the previous screen.

1. To enable address translation, toggle **Address Translation Enabled** to **Yes** (the default). For more information on Network Address Translation, see [Chapter 9, "Multiple Network Address Translation."](#)
2. From the **IP Addressing** menu item, choose between Unnumbered and Numbered addressing. Numbered is the default for ADSL. It assigns a unique IP address to the ADSL WAN interface, as required by most ISPs' routers. Unnumbered may be used for simpler configurations such as point-to-point applications.



If you selected Numbered, the following fields appear.

- Select the editable field labeled **Local WAN IP Address**.

The default address is 0.0.0.0, which allows for dynamic addressing, when your ISP assigns an address each time you connect. However, you can enter another specific address if you want to use static addressing. In that case, enter the local WAN address your ISP gave you. Press Return.

- Select the editable field labeled **Local WAN IP Mask**. Enter the mask address your ISP gave you. Press Return.

If you selected Unnumbered, the following fields appear.

- Select the editable field labeled **Remote IP Address** and enter the remote IP address. Press Return.
  - Select the editable field labeled **Remote IP Mask** and enter the remote mask address. Press Return.
3. If you selected PPP data link encapsulation in the DSL Line Configuration screen, a **PPP Authentication** menu item appears. The authentication protocol and user name/password combinations you enter must be assigned or agreed to in advance between you and your ISP. Select **PPP Authentication** and press Return.

From the pop-up menu that appears, select the authentication method your ISP uses: PAP (Password Authentication Protocol), CHAP (Challenge Handshake Authentication Protocol), or None.

- PAP is the most common, and requires you to enter a User Name and Password in the next two fields.
  - CHAP requires you to enter a Host Name and Secret in the next two fields.
4. Press the Down arrow key until you reach **NEXT SCREEN**. Press Return to bring up the next screen.

## *IP Easy Setup*

The IP Easy Setup screen is where you enter information about your Netopia Router's:

- Ethernet IP address
- Ethernet Subnet mask
- Domain Name
- Domain Name Server IP address
- Default gateway IP address

Consult with your network administrator to obtain the information you will need. For more information about setting up IP, see ["IP Setup" on page 8-2](#).

IP Easy Setup	
Ethernet IP Address:	192.168.1.1
Ethernet Subnet Mask:	255.255.255.0
Domain Name:	isp.net
Primary Domain Name Server:	209.3.224.21
Secondary Domain Name Server:	209.3.224.20
Default IP Gateway:	127.0.0.2
IP Address Serving:	On
Number of Client IP Addresses:	100
1st Client Address:	192.168.1.100
PREVIOUS SCREEN	NEXT SCREEN
Enter an IP address in decimal and dot form (xxx.xxx.xxx.xxx). Set up the basic IP & IPX attributes of your Netopia in this screen.	

1. Select **Ethernet IP Address** and enter the first IP address from the IP address range your ISP has given you. This will be the Netopia Router's IP address.

The Ethernet IP Address defaults to an address (192.168.1.1) within a range reserved by the Internet address administration authority for use within private networks.

Because this is a private network address, it should never be directly connected to the Internet. Using NAT for all your connection profiles will ensure this restriction. See [Chapter 9, "Multiple Network Address Translation,"](#) for more information.

2. Select **Ethernet Subnet Mask** and enter the subnet mask your ISP has given you. The Ethernet Subnet Mask defaults to a standard class mask derived from the class of the Ethernet IP address you entered in the previous step.
3. Press the Down arrow key until the editable field labeled **Domain Name** is highlighted.
4. Type the Domain Name your ISP gave you. Press Return. The next field **Primary Domain Name Server** will be highlighted.
5. Type the Primary Domain Name Server address your ISP gave you. Press Return. A new field **Secondary Domain Name Server** will appear. If your ISP gave you a secondary domain name server address, enter it here. Press Return until the next field **Default IP Gateway** is highlighted.
6. If you do not enter a **Default IP Gateway** value, the router defaults to the remote IP address you entered in the Easy Setup connection profile. If the Netopia Router does not recognize the destination of any IP traffic, it forwards that traffic to this gateway.

Do not confuse the remote IP address and the Default IP Gateway's address with the block of local IP addresses you receive from your ISP. You use the local IP addresses for the Netopia 4541/4542's Ethernet port and for IP clients on your local network. The remote IP address and the default gateway's IP address should point to your ISP's router.

7. Toggle **IP Address Serving** to On or Off, depending on whether you want the device's IP address server to supply dynamic IP addresses to your client workstations. Normally, you would accept the default On so that workstations on your LAN can have IP addresses assigned dynamically from the router.
8. The IP address server will provide 100 IP addresses automatically to workstations on your LAN. You only need to change the **Number of Client IP Addresses** if you have some other IP addressing scheme.
9. By default, the **1st Client Address** is 192.168.1.100, based on the device's default IP address of 192.168.1.1. You only need to change this if you have some other IP addressing scheme.
10. Press the Down arrow key until you reach **NEXT SCREEN**. Press Return.

## Easy Setup Security Configuration

The Easy Setup Security Configuration screen lets you password-protect your Netopia 4541/4542. Input your **Write Access Name** and **Write Access Password** with names or numbers totaling up to eleven digits.

If you password protect the console screens, you will be prompted to enter the name and password you have specified every time you log in to the console screens. Do not forget your name and password. If you do, you will be unable to access any of the configuration screens.

Additional security features are available. See "[Security](#)" on page 11-1.

Easy Setup Security Configuration

It is strongly suggested that you password-protect configuration access to your Netopia. By entering a Name and Password pair here, access via serial, Telnet, and SNMP will be password-protected.

Be sure to remember what you have typed here, because you will be prompted for it each time you configure this Netopia.

Write Access Name:

Write Access Password:

PREVIOUS SCREEN            TO MAIN MENU            RESTART DEVICE

Configure a Configuration Access Name and Password here.

The final step in configuring the Easy Setup console screens is to restart the Netopia 4541/4542, so that the configuration settings take effect.

1. Select **RESTART DEVICE**. A prompt asks you to confirm your choice.
2. Select **CONTINUE** to restart the Netopia Router and have your selections take effect.

**Note:** You can also restart the system at any time by using the Restart System utility (see "[Restarting the system](#)" on page 13-12) or by turning the Netopia Router off and on with the power switch.

## **6-8 User's Reference Guide**

The Router will restart and your configuration settings will be activated. You can then Exit or Quit your Telnet application.

Easy Setup is now complete.

## Chapter 7

# WAN and System Configuration

This chapter describes how to use the console-based management screens to access and configure advanced features of your Netopia 4541/4542 ADSL Router. You can customize these features for your individual setup. These menus provide a powerful method for experienced users to set up their router's connection profiles and system configuration.

This section covers the following topics:

- "WAN configuration" on page 7-1
- "Creating a new Connection Profile" on page 7-4
- "The default profile" on page 7-7
- "Scheduled connections" on page 7-8
- "System configuration screens" on page 7-13
- "Navigating through the system configuration screens" on page 7-14
- "System configuration features" on page 7-15

---

### WAN configuration

To configure your Wide Area Network (WAN) connection, navigate to the WAN Configuration screen from the Main Menu and select **WAN (Wide Area Network) Setup**.

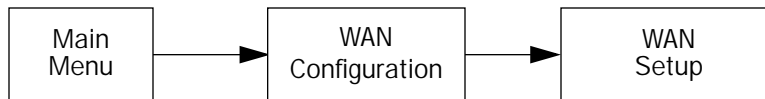

The ADSL Line Configuration screen appears.

```

                                ADSL Line Configuration

Circuit Type...                  Multimode

Signaling Mode...                FDM
Trellis Coding Enabled:         On

Cell Format...                   Scrambled
Unused Cell Format...            Idle

Data Link Encapsulation...      RFC1483
RFC1483 Mode...                 Bridged 1483
PPP over Ethernet (PPPoE):      Off

Display/Change Circuit...
Add Circuit...
Delete Circuit...

```

1. Select **Circuit Type** and from the pop-up menu choose the type of circuit to which you will be connecting.
  - Model 4541 offers Multimode, T1.413, G.dmt, G.lite, or ADI.
  - Model 4542 offers Multimode, ADI ETDI, ITU Standard, UR2, ADI Legacy, TI Legacy and Alcatel ETSI.
2. Select **Signaling Mode** and choose Echo Cancellation or FDM (the default).
3. If you selected Multimode or G.lite as the Circuit Type, the **Trellis Coding Enabled** field appears. Toggle it to On (the default) or Off.
4. Select whether the **Cell Format** is Unscrambled (the default) or Scrambled, and whether the **Unused Cell Format** is Empty or Idle (the default).
5. Select **Data Link Encapsulation** and press Return. The pop-up menu will offer you the choice of PPP or RFC1483.
  - If you selected PPP as your data link encapsulation method, the **PPP Mode** pop-up menu offers the choice of VC Multiplexed (the default) or LLC SNAP.
  - If you selected RFC1483 your data link encapsulation method, two additional options display: an **RFC1483 Mode** pop-up menu offers the choice of Bridged 1483 or Routed 1483. Bridged 1483 permits use of **PPP over Ethernet (PPPoE)** and is the default. You can then toggle PPPoE On or Off. Choosing Routed 1483 hides the PPPoE option.
6. To add a circuit, select **Add Circuit** and press Return. The Add Circuit screen appears.

Add Circuit	
Circuit Name:	Circuit 2
Circuit Enabled:	Yes
Circuit VPI (0-255):	0
Circuit VCI (0-65535):	0
Use Connection Profile...	Default Profile
Use Default Profile for Circuit	
ADD Circuit NOW	CANCEL

- Enter a name for the circuit in the Circuit Name field.
  - Toggle **Circuit Enabled** to Yes.
  - Enter the Virtual Path Identifier and the Virtual Channel Identifier in the **Circuit VPI** and **Circuit VCI** fields, respectively.
  - Then, select a Connection Profile for the Circuit. To use the Default Profile, select **Use Default Profile for Circuit** and press Return. For other options, select a profile from the **Use Connection Profile** pop-up menu.
  - Select **ADD Circuit NOW** and press Return.
7. To display or change a circuit, select **Display/Change Circuit**, select a circuit from the pop-up menu, and press Return. The fields are the same as those in the Add Circuit screen.
  8. To delete a circuit, select Delete Circuit, select a circuit from the pop-up menu, and press Return. In the confirmation window, select CONTINUE and press Return.
  9. Press Escape to return to the WAN Setup menu.

---

## Creating a new Connection Profile

For a Netopia 4541/4542, connection profiles are useful for configuring the connection and authentication settings for negotiating a PPP connection on the ADSL link. If you are using the PPP data link encapsulation method, you can store your authentication information in the connection profile so that your user name and password (or host name and secret) are transmitted when you attempt to connect.

Connection profiles define the networking protocols necessary for the router to make a remote connection. A connection profile is like an address book entry describing how the router is to get to a remote site, or how to recognize and authenticate a connection. To create a new connection profile, you navigate to the WAN Configuration screen from the Main Menu, and select **Add Connection Profile**.

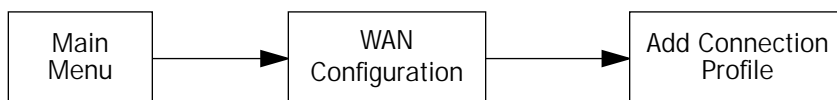

The **Add Connection Profile** screen appears.

```

                                Add Connection Profile

Profile Name:                      Profile 1
Profile Enabled:                    Yes
Data Link Encapsulation...         PPP
Data Link Options...

IP Profile Parameters...

COMMIT                               CANCEL

Configure a new Conn. Profile. Finished? ADD or CANCEL to exit.
```

On a Netopia 4541/4542 you can add up to 15 more connection profiles, for a total of 16, but you can only use one at a time, unless you are using VPNs.

1. Select **Profile Name** and enter a name for this connection profile. It can be any name you wish. For example: the name of your ISP.
2. Toggle **Profile Enabled** to **Yes** or **No**. The default is Yes.



3. Select **Data Link Encapsulation** and press Return. The pop-up menu offers the possible data link encapsulation methods for connection profiles used for a variety of purposes: PPP, RFC1483, ATMP, PPTP, or IPsec. If you select any data link encapsulation method other than RFC1483, a **Data Link Options** menu item is displayed; if you select RFC1483, Data Link Options is hidden.
4. If you chose any data link encapsulation method other than RFC1483, select **Datalink Options** and press Return.
  - If you selected ATMP, PPTP, or IPsec, see [Chapter 10, "Virtual Private Networks \(VPNs\)."](#)
  - If you selected PPP, the Datalink (PPP/MP) Options screen appears.

Datalink (PPP/MP) Options

Data Compression...	Standard LZS
Send Authentication...	PAP
Send User Name:	
Send Password:	
Receive User Name:	
Receive Password:	
Maximum Packet Size:	1500

In this Screen you will configure the PPP/MP specific connection params.

Select **Data Compression** and press Return. The pop-up menu offers the choices of None, Ascend LZS, or Standard LZS. Unless you are otherwise specifically directed, you can accept the default.

Select **Send Authentication** and press Return.

From the pop-up menu that appears, select the authentication method your ISP uses, if any: PAP (Password Authentication Protocol), CHAP (Challenge Handshake Authentication Protocol), or None.

- PAP is the most common, and requires you to enter a User Name and Password in the next two fields.
- CHAP requires you to enter a Host Name and Secret in the next two fields.

You can specify user name and password for both outgoing and incoming connections. The Send User Name/Password parameters are used to specify your identity when connecting to a remote location. The Receive User Name/Password parameters are used when the ISP router requires authentication; this is not commonly required.

5. You can edit the **Maximum Packet Size** field, if you want packets limited to a lower value than 1500. Return to the Add Connection Profile screen by pressing Escape.
6. Select **IP Profile Parameters** and press Return. The IP Profile Parameters screen appears.

```

                                IP Profile Parameters

Address Translation Enabled:      Yes
IP Addressing...                 Numbered

NAT Map List...                  Easy-PAT List
NAT Server List...              Easy-Servers

Local WAN IP Address:           0.0.0.0
Local WAN IP Mask:              0.0.0.0

Filter Set...
Remove Filter Set

RIP Profile Options...

```

7. Toggle or enter any IP Parameters you require and return to the Add Connection Profile screen by pressing Escape. For more information, see ["IP Setup" on page 8-2](#).
8. Select **COMMIT** and press Return. Your new Connection Profile will be added.

If you want to view the Connection Profiles in your device, return to the WAN Configuration screen, and select **Display/Change Connection Profile**. The list of Connection Profiles is displayed in a scrolling pop-up screen.

```

                                WAN Configuration
+--Profile Name-----IP Address-----+
+-----+-----+
Easy Setup Profile      255.225.255.255
Profile 1                0.0.0.0
+-----+-----+

```

---

## The default profile

If you are using RFC1483 datalink encapsulation, the Default Profile screen controls whether or not the ADSL link will come up without an explicitly configured connection profile. (PPP datalink encapsulation does not support a default profile, and the corresponding menu item is unavailable.) See [“Connection Profiles” on page 8-25](#) for more information.

You access the Default Profile screen from the Main Menu by selecting WAN Configuration and then selecting **Default Profile**.

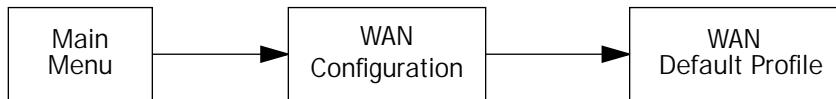

The Default Profile screen appears.

WAN Default Profile

Must Match a Defined Profile:      No

IP Parameters...

- You can set Must Match a Defined Profile item to Yes or No (the default). This item controls whether or not the ADSL link will come up without an explicitly configured connection profile. If your ISP is serving you a dynamic IP Address, you need not explicitly configure a connection profile, and the default behavior of the router will be to connect automatically once it is powered on.

## IP parameters (default profile) screen

If you are using RFC1483 datalink encapsulation, the IP Parameters (Default Profile) screen allows you to configure various IP parameters for ADSL connections established without an explicitly configured connection profile:

```
IP Parameters (Default Profile)

Address Translation Enabled:      No

Filter Set (Firewall)...
Remove Filter Set

Receive RIP:                      Both
Transmit RIP:                     Off

Return/Enter accepts * Tab toggles * ESC cancels.
```

For an ADSL link, Network Address Translation (NAT) is disabled by default in the Default Profile. You can enable it by toggling to Yes. For details on setting up IP Parameters see ["IP Setup" on page 8-2](#).

---

## Scheduled connections

Scheduled connections are useful for PPPoE, PPTP, and ATMP connection profiles.

To go to the Scheduled Connections screen, select **Scheduled Connections** in the WAN Configuration screen.

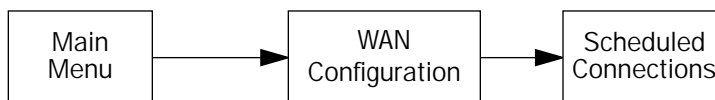

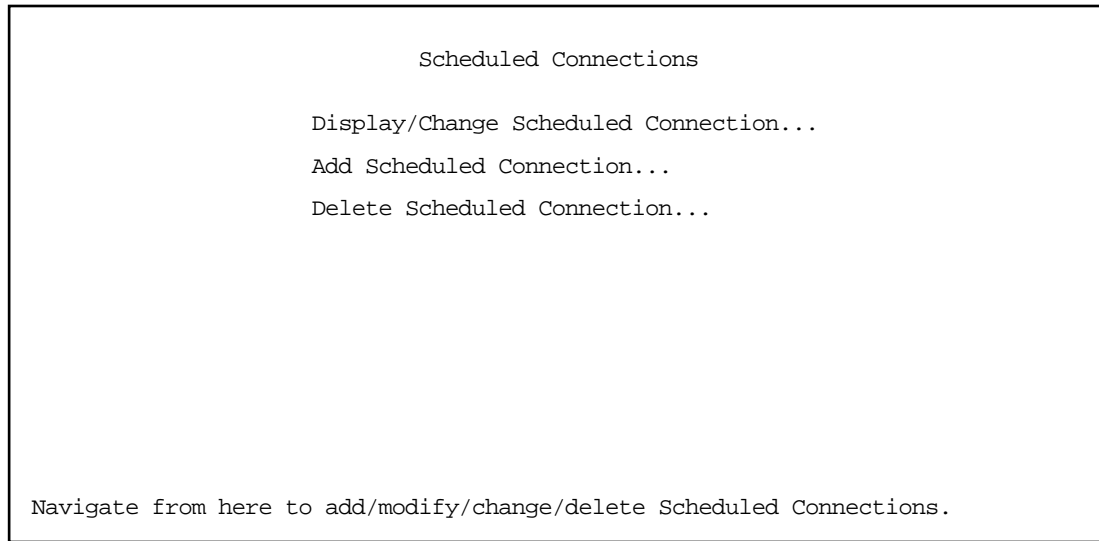

### Viewing scheduled connections

To display a table of scheduled connections, select **Display/Change Scheduled Connection** in the Scheduled Connections screen. Each scheduled connection occupies one row of the table.

Scheduled Connections

+-Days----	Begin At---HH:MM--	When----	Conn. Prof. Name----	Enabled-----+
mtWtfss	08:30PM	06:00	weekly Profile 01	No

The first column in the table shows a one-letter representation of the **Days** of the week, from Monday (M or m) to Sunday (S or s). If a letter representing a day is capitalized, the connection will be activated on that day; a lower-case letter means that the connection will not be activated on that day. If the scheduled connection is configured for a once-only connection, the word "once" will appear instead of the days of the week.

The other columns show:

- The time of day that the connection will **Begin At**
- The duration of the connection (**HH:MM**)
- Whether it's a recurring **Weekly** connection or used **Once Only**
- Which connection profile (**Conn. Prof.**) is used to connect
- Whether the scheduled connection is currently **Enabled**

The router checks the date and time set in scheduled connections against the system date and time.

### *Adding a scheduled connection*

To add a new scheduled connection, select **Add Scheduled Connection** in the Scheduled Connections screen and press Return. The Add Scheduled Connection screen appears.

Add Scheduled Connection

Scheduled Connection Enable:	On
How Often...	Weekly
Schedule Type...	Forced
Set Weekly Schedule...	
Use Connection Profile...	

ADD SCHEDULED CONNECTION                      CANCEL

Scheduled Connections dial remote Networks on a Weekly or Once-Only basis.

Follow these steps to configure the new scheduled connection:

- To activate the connection, select **Scheduled Connection Enable** and toggle it to **On**. You can make the scheduled connection inactive by toggling **Scheduled Connection Enable** to **Off**.
- Decide how often the connection should take place by selecting **How Often** and choosing **Weekly** or **Once Only** from the pop-up menu.
- The **Schedule Type** allows you to set the exact weekly schedule or once-only schedule.

Options are:

- **Forced Up**, meaning that this connection will be maintained whether or not there is a demand call on the line.
- **Forced Down**, meaning that this connection will be torn down or blocked whether or not there is a

demand call on the line.

- **Demand-Allowed**, meaning that this schedule will permit a demand call on the line.
- **Demand-Blocked**, meaning that this schedule will prevent a demand call on the line.
- **Periodic**, meaning that the connection is retried several times during the scheduled time.
- If **How Often** is set to **Weekly**, the item directly below **How Often** reads **Set Weekly Schedule**. If **How Often** is set to **Once Only**, the item directly below **How Often** reads **Set Once-Only Schedule**.

## Set Weekly Schedule

If you set **How Often** to **Weekly**, select **Set Weekly Schedule** and go to the Set Weekly Schedule screen.

- Select the days for the scheduled connection to occur and toggle them to **Yes**.

Set Weekly Schedule

Monday:	No
Tuesday:	No
Wednesday:	No
Thursday:	No
Friday:	No
Saturday:	No
Sunday:	No
Scheduled Window Start Time:	11:50
AM or PM:	AM
Scheduled Window Duration Per Day:	00:00

- Select **Scheduled Window Start Time** and enter the time to initiate the scheduled connection.
- You must enter the time in the format H:M, where H is a one- or two-digit number representing the hour and M is a one- or two-digit number representing the minutes. The colon is mandatory. For example, the entry 1:3 (or 1:03) would be accepted as 3 minutes after one o'clock. The entry 7:0 (or 7:00) would be accepted as seven o'clock, exactly. The entries 44, :5, and 2: would be rejected.
- Select **AM or PM** and choose **AM** or **PM** from the pop-up menu.
- Select **Scheduled Window Duration Per Day** and enter the maximum duration allowed for this scheduled connection, per call.

You are finished configuring the weekly options. Return to the Add Scheduled Connection screen to continue.

## Set Once-Only Schedule

If you set **How Often** to **Once Only**, select **Set Once-Only Schedule** and go to the Set Once-Only Schedule screen.

Set Once-Only Schedule

Place Call on (MM/DD/YY):	05/07/1998
Scheduled Window Start Time: AM or PM:	11:50 AM
Scheduled Window Duration:	00:00

- Select **Place Call On (Date)** and enter a date in the format MM/DD/YY or MM/DD/YYYY (month, day, year).

**Note:** You must enter the date in the format specified. The slashes are mandatory. For example, the entry 5/7/98 would be accepted as May 7, 1998. The entry 5/7 would be rejected.

- Select **Scheduled Window Start Time** and enter the time to initiate the scheduled connection.

**Note:** You must enter the time in the format H:M, where H is a one- or two-digit number representing the hour and M is a one- or two-digit number representing the minutes. The colon is mandatory. For example, the entry 1:3 (or 1:03) would be accepted as 3 minutes after one o'clock. The entry 7:0 (or 7:00) would be accepted as seven o'clock, exactly. The entries 44, :5, and 2: would be rejected.

- Select **AM or PM** and choose **AM** or **PM**.
- Select **Scheduled Window Duration** and enter the maximum duration allowed for this scheduled connection. Use the same format restrictions noted above.

You are finished configuring the once-only options. Return to the Add Scheduled Connection screen to continue.

- In the Add Scheduled Connection screen, select **Use Connection Profile** and choose from the list of connection profiles you have already created. A scheduled connection must be associated with a connection profile to be useful. The connection profile becomes active during the times specified in the associated scheduled connection, if any exists.
- Select **ADD SCHEDULED CONNECTION** to save the current scheduled connection. Select **CANCEL** to exit the Add Scheduled Connection screen without saving the new scheduled connection.



## *Modifying a scheduled connection*

To modify a scheduled connection, select **Display/Change Scheduled Connection** in the Scheduled Connections screen to display a table of scheduled connections.

Select a scheduled connection from the table and press Return. The Change Scheduled Connection screen appears. The parameters in this screen are the same as the ones in the Add Scheduled Connection screen (except that **ADD SCHEDULED CONNECTION** and **CANCEL** do not appear). To find out how to set them, see [“Adding a scheduled connection” on page 7-10](#).

## *Deleting a scheduled connection*

To delete a scheduled connection, select **Delete Scheduled Connection** in the Scheduled Connections screen to display a table of scheduled connections.

Select a scheduled connection from the table and press the Return key to delete it. To exit the table without deleting the selected scheduled connection, press the Escape key.

---

## *System configuration screens*

You can connect to the Netopia 4541/4542's system configuration screens in either of two ways:

- By using Telnet with the Router's Ethernet port IP address
- Through the console port, using a local terminal (see [“Connecting a console cable to your router” on page 5-3](#))

You can also retrieve the Netopia 4541/4542's configuration information and remotely set its parameters using the Simple Network Management Protocol (see [“SNMP” on page 12-9](#)).

Open a Telnet connection to the router's IP address; for example, “192.168.1.1.”

The console screen will open to the Main Menu, similar to the screen shown below:

```
Netopia Router

Easy Setup...
WAN Configuration...
System Configuration...
Utilities & Diagnostics...
Statistics & Logs...
Quick Menu...
Quick View...

Return/Enter goes to Easy Setup -- minimal configuration.
You always start from this main screen.
```

---

### *Navigating through the system configuration screens*

To help you find your way to particular screens, some sections in this guide begin with a graphical path guide similar to the following example:

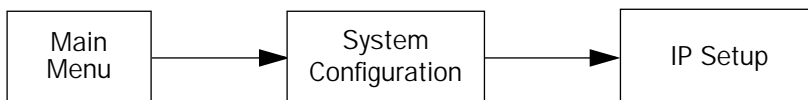

This particular path guide shows how to get to the Network Protocols Setup screens. The path guide represents these steps:

1. Beginning in the Main Menu, select **System Configuration** and press Return. The System Configuration screen appears.
2. Select **IP Setup** and press Return. The IP Setup screen appears.

To go back in this sequence of screens, use the Escape key.

## System configuration features

The Netopia 4541/4542 ADSL Router's default settings may be all you need to configure your Netopia 4541/4542. Some users, however, require advanced settings or prefer manual control over the default selections. For these users, the Netopia 4541/4542 provides system configuration options.

To help you determine whether you need to use the system configuration options, review the following requirements. If you have one or more of these needs, use the system configuration options described in later chapters.

- System configuration of dynamic IP address distribution through DHCP or BootP
- Greater network security through the use of filters
- Use of Network Time Protocol

To access the system configuration screens, select **System Configuration** in the Main Menu, then press Return.

The System Configuration menu screen appears:

```
System Configuration

IP Setup...
Filter Sets (Firewalls)...
IP Address Serving...

Date and Time...

Console Configuration...

SNMP (Simple Network Management Protocol)...

Security...

Upgrade Feature Set...

Logging...

Return/Enter to configure Networking Protocols (such as TCP/IP).
Use this screen if you want options beyond Easy Setup.
```

## IP setup

These screens allow you to configure your network's use of the IP networking protocol.

- Details are given in "IP Setup" on page 8-2.

## Filter sets (firewalls)

These screens allow you to configure security on your network by means of filter sets and a basic firewall.

- Details are given in "Security" on page 11-1.

## IP address serving

These screens allow you to configure IP address serving on your network by means of DHCP, WANIP, and BootP.

- Details are given in "IP Address Serving" on page 8-10.

## Date and time

You can set the system's date and time parameters in the Set Date and Time screen.

Select **Date and Time** in the System Configuration screen and press Return. The Set Date and Time screen appears.

```
Set Date and Time

NTP (Network Time Prot.) Enabled: On
Time Server Host Name/IP Address 204.152.184.72
Time Zone... GMT -8:00 Pacific Standard Time
NTP Update Interval (HHHH:MM) 0:00

System Date Format: MM/DD/YY

System Time Format: AM/PM
```

Follow these steps to set the system's date and time:

1. Toggle **NTP (Network Time Prot.) Enabled** to On to synchronize the Router's time and date with a network server. Toggle this field to Off to manually set the time and date; the options in this screen will change to allow you to manually enter the time and date parameters.

**Note:** If time and date are manually set, that information will be lost upon reboot or loss of power.

2. Enter the IP address of the time server in the field **Time Server Host Name/IP Address**.

3. Select the Router's time zone from the **Time Zone** pop-up menu and press Return.
4. In the **NTP Update Interval** field, enter how often to synchronize with the time server, using the format HHHH:MM where H is hours and M is minutes.
5. Select a **System Date Format**; the options are MM/DD/YY, DD/MM/YY, and YY/MM/DD, where M is month, D is day, and Y is year.
6. Select a **System Time Format**, either AM/PM or 24hrs.
7. Press Escape to return to the System Configuration menu.

## Console configuration

You can change the default terminal communications parameters to suit your requirements.

To go to the Console Configuration screen, select **Console Configuration** in the System Configuration screen.

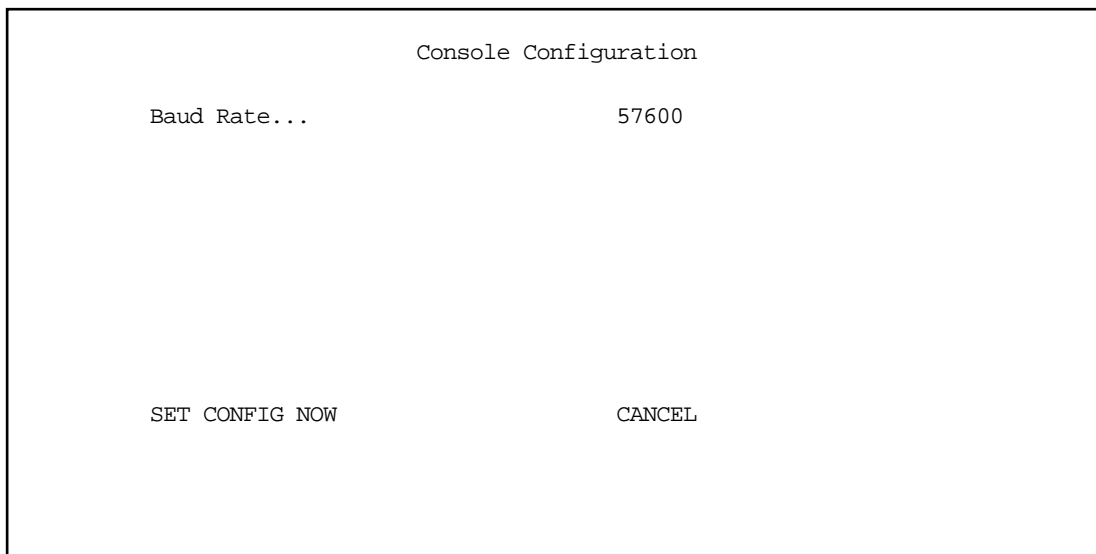

The screenshot shows a terminal window titled "Console Configuration". The text "Baud Rate..." is on the left and "57600" is on the right. At the bottom, there are two options: "SET CONFIG NOW" on the left and "CANCEL" on the right.

Follow these steps to change a parameter's value:

1. Select 57600, 38400, 19200, or 9600.
2. Select **SET CONFIG NOW** to save the new parameter settings. Select **CANCEL** to leave the parameter unchanged and exit the Console Configuration screen.

## SNMP (Simple Network Management Protocol)

These screens allow you to monitor and configure your network by means of a standard Simple Network Management Protocol (SNMP) agent.

- Details are given in "SNMP" on page 12-9.

## Security

These screens allow you to add users and define passwords on your network.

- Details are given in “Security” on page 11-1.

## Upgrade feature set

You can upgrade your Netopia 4541/4542 by adding new feature sets through the Upgrade Feature Set utility.

See the release notes that came with your router or feature set upgrade, or visit the Netopia Web site at [www.netopia.com](http://www.netopia.com) for information on new feature sets, how to obtain them, and how to install them on your Netopia 4541/4542.

## Logging

You can configure a UNIX-compatible syslog client to report a number of subsets of the events entered in the router's WAN Event History. See “WAN Event History” on page 12-5.

The Syslog client (for the PC only) is available on the Netopia CD.

Select **Logging** from the System Configuration menu.

The Logging Configuration screen appears.

Logging Configuration	
WAN Event Log Options	
Log Boot and Errors:	Yes
Log Line Specific:	Yes
Log Connections:	Yes
Log PPP, DHCP, CNA:	Yes
Log IP:	Yes
Syslog Parameters	
Syslog Enabled:	No
Hostname or IP Address:	
Facility...	Local 0

By default, all events are logged in the event history.

- By toggling each event descriptor to either **Yes** or **No**, you can determine which ones are logged and which are ignored.
- You can enable or disable the syslog client dynamically. When enabled, it will report any appropriate and previously unreported events.
- You can specify the syslog server's address either in dotted decimal format or as a DNS name up to 63 characters.

- You can specify the UNIX syslog Facility to use by selecting the **Facility** pop-up.
- Erase the log by selecting DUMP WAN LOG

## Installing the Syslog client

The Goodies folder on the Netopia CD contains a Syslog client daemon program that can be configured to report the WAN events you specified in the Logging Configuration screen.

To install the Syslog client daemon, exit from the graphical Netopia CD program and locate the CD directory structure through your Windows desktop or through Windows Explorer. Go to the Goodies directory on the CD and locate the Sds15000.exe program. This is the Syslog daemon installer. Run the Sds15000.exe program and follow the on-screen instructions for enabling the Windows Syslog daemon.

The following screen shows a sample syslog dump of WAN events:

```

May 5 10:14:06 tsnext.netopia.com Link 1 down: PPP PAP failure
May 5 10:14:06 tsnext.netopia.com >>Issued Speech Setup Request from our DN: 5108645534
May 5 10:14:06 tsnext.netopia.com Requested Disc. from DN: 917143652500
May 5 10:14:06 tsnext.netopia.com Received Clear Confirm for our DN: 5108645534
May 5 10:14:06 tsnext.netopia.com Link 1 down: Manual disconnect
May 5 10:14:06 tsnext.netopia.com >>Issued Speech Setup Request from our DN: 5108645534
May 5 10:14:06 tsnext.netopia.com Requested Disc. from DN: 917143652500
May 5 10:14:06 tsnext.netopia.com Received Clear Confirm for our DN: 5108645534
May 5 10:14:06 tsnext.netopia.com Link 1 down: No answer
May 5 10:14:06 tsnext.netopia.com --Device restarted-----
May 5 10:14:06 tsnext.netopia.com >>Received Speech Setup Ind. from DN: (not supplied)
May 5 10:14:06 tsnext.netopia.com Requested Connect to our DN: 5108645534
May 5 10:14:06 tsnext.netopia.com ASYNC: Modem carrier detected (more) Modem reports: 26400
V34
May 5 10:14:06 tsnext.netopia.com >>WAN: 56K Modem 1 activated at 115 Kbps
May 5 10:14:06 tsnext.netopia.com Connect Confirmed to our DN: 5108645534
May 5 10:14:06 tsnext.netopia.com PPP: Channel 1 up, Answer Profile name: Default Profile
May 5 10:14:06 tsnext.netopia.com PPP: NCP up, session 1, Channel 1 Final (fallback)
negotiated auth: Local PAP , Remote NONE
May 5 10:14:06 tsnext.netopia.com PPP: PAP we accepted remote, Channel 1 Remote name: guest
May 5 10:14:06 tsnext.netopia.com PPP: MP negotiated, session 1 Remote EDO: 06 03
0000C5700624 0
May 5 10:14:06 tsnext.netopia.com PPP: CCP negotiated, session 1, type: Ascend LZS Local
mode: 1, Remote mode: 1
May 5 10:14:06 tsnext.netopia.com PPP: BACP negotiated, session 1 Local MN: FFFFFFFF, Remote
MN: 00000001
May 5 10:14:06 tsnext.netopia.com PPP: IPCP negotiated, session 1, rem: 192.168.10.100 local:
192.168.1.1
May 5 10:14:06 tsnext.netopia.com >>WAN: 56K Modem 1 deactivated
May 5 10:14:06 tsnext.netopia.com Received Clear Ind. from DN: 5108645534, Cause: 0
May 5 10:14:06 tsnext.netopia.com Issued Clear Response to DN: 5108645534
May 5 10:14:06 tsnext.netopia.com Link 1 down: Remote clearing
May 5 10:14:06 tsnext.netopia.com PPP: IPCP down, session 1
May 5 10:14:06 tsnext.netopia.com >>Received Speech Setup Ind. from DN: (not supplied)

```





# Chapter 8

## IP Setup

The Netopia 4541/4542 uses Internet Protocol (IP) to communicate both locally and with remote networks. This chapter shows you how to configure the router to route IP traffic. You also learn how to configure the router to serve IP addresses to hosts on your local network.

Netopia's IP routing features Network Address Translation and IP address serving.

This section covers the following topics:

- ["IP Setup" on page 8-2](#)
- ["IP Address Serving" on page 8-10](#)
- ["More Address Serving Options" on page 8-17](#)
- ["DHCP Relay Agent" on page 8-23](#)
- ["Connection Profiles" on page 8-25](#)

Network Address Translation allows communication between the LAN connected to the Netopia 4541/4542 and the Internet using a single (or a few) IP address(es) instead of a routed account with separate IP addresses for each computer on the network.

Network Address Translation also provides increased security by hiding the local IP addresses of the LAN connected to the Netopia 4541/4542 from the outside world.

The setup is simpler, so ISPs typically offer Internet accounts supporting Network Address Translation at a significant cost savings.

For a detailed discussion of Network Address Translation, see [Chapter 9, "Multiple Network Address Translation."](#)

## IP Setup

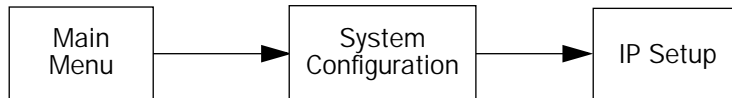

The IP Setup options screen is where you configure the Ethernet side of the Netopia 4541/4542. The information you enter here controls how the router routes IP traffic.

Consult your network administrator or ISP to obtain the IP setup information (such as the Ethernet IP address, Ethernet subnet mask, default IP gateway, and Primary Domain Name Server IP address) you will need before changing any of the settings in this screen. Changes to these settings that you make in this screen will take effect only after the Netopia 4541/4542 is reset.

To go to the IP Setup options screen, from the Main Menu, select **System Configuration**, then **IP Setup**.

The IP Setup screen appears.

```

                                     IP Setup

Ethernet IP Address:                  192.128.117.162
Ethernet Subnet Mask:                255.255.255.0
Define Additional Subnets...

Default IP Gateway:                  192.128.117.163

Primary Domain Name Server:          0.0.0.0
Secondary Domain Name Server:        0.0.0.0
Domain Name:                          yourdomain.com

Receive RIP...                        Both
Transmit RIP...                       Off

Static Routes...                      IP Address Serving...
Network Address Translation (NAT)...
```

Follow these steps to configure IP setup for your Netopia 4541/4542:

- Select **Ethernet IP Address** and enter the IP address for the Netopia 4541/4542's Ethernet port.
- Select **Ethernet Subnet Mask** and enter the subnet mask for the Ethernet IP address that you entered in the last step.
- If you desire multiple subnets select **Define Additional Subnets**. If you select this item you will be taken to the IP Subnets screen. This screen allows you to define IP addresses and masks for additional subnets. See "IP subnets" on page 8-4 for details.

The Netopia 4541/4542 supports multiple IP subnets on the Ethernet interface. You may want to configure multiple IP subnets to service more hosts than are possible with your primary subnet. It is not always possible to obtain a larger subnet from your ISP. For example, if you already have a full Class C subnet, your only option is multiple Class C subnets, since it is virtually impossible to justify a Class A or Class B assignment.

If you are using NAT, you can use the reserved Class A or Class B subnet.

- Select **Default IP Gateway** and enter the IP address for a default gateway. This can be the address of any major router accessible to the Netopia 4541/4542.
 

A default gateway should be able to successfully route packets when the Netopia 4541/4542 doesn't know how to route to the intended recipient's IP address. Typically, a default gateway is the ISP's router.
- Select **Primary Domain Name Server** and enter the IP address for a domain name server. The domain name server matches the alphabetic addresses favored by people (for example, robin.hood.com) to the IP addresses actually used by IP routers (for example, 163.7.8.202).
- If a secondary DNS server is available, select **Secondary Domain Name Server** and enter its IP address. The secondary DNS server is used by the Netopia 4541/4542 when the primary DNS server is inaccessible. Entering a secondary DNS is useful but not necessary.
- Select **Domain Name** and enter your network's domain name (for example, netopia.com). Netopia strongly recommends that you enter a domain name.
- Routing Information Protocol (RIP) is needed if there are IP routers on other segments of your Ethernet network that the Netopia 4541/4542 needs to recognize. If this is the case select **Receive RIP** and select **v1**, **v2**, or **Both** from the pop-up menu. With Receive RIP set to v1, the Netopia 4541/4542's Ethernet port will accept routing information provided by RIP packets from other routers that use the same subnet mask. Set to v2, the Netopia 4541/4542 will accept routing information provided by RIP packets from other routers that use different subnet masks. Set to Both, the Netopia 4541/4542 will accept information from either RIP v1 or v2 routers.
- If you want the Netopia 4541/4542 to advertise its routing table to other routers via RIP, select **Transmit RIP** and select **v1**, **v2 (broadcast)**, or **v2 (multicast)** from the pop-up menu. With Transmit RIP v1 selected, the Netopia 4541/4542 will generate RIP packets only to other RIP v1 routers. With Transmit RIP v2 (broadcast) selected, the Netopia 4541/4542 will generate RIP packets to all other hosts on the network. With Transmit RIP v2 (multicast) selected, the Netopia 4541/4542 will generate RIP packets only to other routers capable of recognizing RIP v2 packets.
- Select **Static Routes** to manually configure IP routes. See the section "[Static routes](#)," below.
- Select **Network Address Translation** to configure advanced MultiNAT features. See [Chapter 9, "Multiple Network Address Translation."](#)
- If you select **IP Address Serving** you will be taken to the IP Address Serving screen (see "[IP Address Serving](#)" on page 8-10). Since no two hosts can use the same IP address at the same time, make sure that the addresses distributed by the Netopia 4541/4542 and those that are manually configured are not the same. Each method of distribution must have its own exclusive range of addresses to draw from.

## IP subnets

The IP Subnets screen allows you to configure up to eight Ethernet IP subnets on unlimited-user models, one "primary" subnet and up to seven secondary subnets, by entering IP address/subnet mask pairs:

IP Subnets		
	IP Address	Subnet Mask
#1:	192.128.117.162	255.255.255.0
#2:	0.0.0.0	0.0.0.0
#3:		
#4:		
#5:		
#6:		
#7:		
#8:		

Note: You need not use this screen if you have only a single Ethernet IP subnet. In that case, you can continue to enter or edit the IP address and subnet mask for the single subnet on the IP Setup screen.

This screen displays up to eight rows of two editable columns, preceded by a row number between one and eight. If you have eight subnets configured, there will be eight rows on this screen. Otherwise, there will be one more row than the number of configured subnets. The last row will have the value 0.0.0.0 in both the IP address and subnet mask fields to indicate that you can edit the values in this row to configure an additional subnet. All eight row labels are always visible, regardless of the number of subnets configured.

- To add an IP subnet, enter the Netopia 4541/4542's IP address on the subnet in the **IP Address** field in a particular row and the subnet mask for the subnet in the **Subnet Mask** field in that row.

For example:

IP Subnets	
IP Address	Subnet Mask
#1: 192.128.117.162	255.255.255.0
#2: 192.128.152.162	255.255.0.0
#3: 0.0.0.0	0.0.0.0
#4:	
#5:	
#6:	
#7:	
#8:	

- To delete a configured subnet, set both the IP address and subnet mask values to 0.0.0.0, either explicitly or by clearing each field and pressing Return to commit the change. When a configured subnet is deleted, the values in subsequent rows adjust up to fill the vacant fields.

The subnets configured on this screen are tied to the address serving pools configured on the IP Address Pools screen, and that changes on this screen may affect the IP Address Pools screen. In particular, deleting a subnet configured on this screen will delete the corresponding address serving pool, if any, on the IP Address Pools screen.

If you have configured multiple Ethernet IP subnets, the IP Setup screen changes slightly:

```

                                     IP Setup

Subnet Configuration...

Default IP Gateway:                  192.128.117.163

Primary Domain Name Server:         0.0.0.0
Secondary Domain Name Server:       0.0.0.0
Domain Name:

Receive RIP...                       Both
Transmit RIP...                       v2 (multicast)

Static Routes...                      IP Address Serving...
Network Address Translation (NAT)...

Set up the basic IP attributes of your Netopia in this screen.
```

The IP address and Subnet mask items are hidden, and the **Define Additional Subnets...** item becomes **Subnet Configuration...**. If you select **Subnet Configuration**, you will return to the IP Subnets screen that allows you to define IP addresses and masks for additional Ethernet IP subnets.

### *Static routes*

Static routes are IP routes that are maintained manually. Each static route acts as a pointer that tells the Netopia 4541/4542 how to reach a particular network. However, static routes are used only if they appear in the IP routing table, which contains all of the routes used by the Netopia 4541/4542 (see ["IP Routing Table" on page 12-7](#)).

Static routes are helpful in situations where a route to a network must be used and other means of finding the route are unavailable. For example, static routes are useful when you cannot rely on RIP.

To go to the Static Routes screen, select **Static Routes** in the IP Setup screen and press Return.

The Static Routes screen will appear.

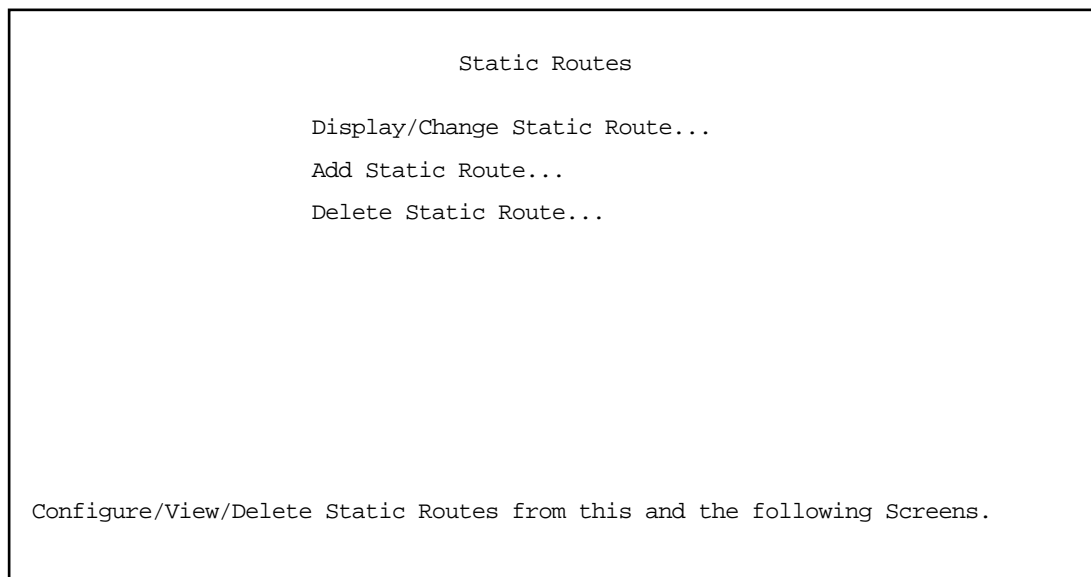

### Viewing static routes

To display a view-only table of static routes, select **Display/Change Static Route**. The table shown below will appear.

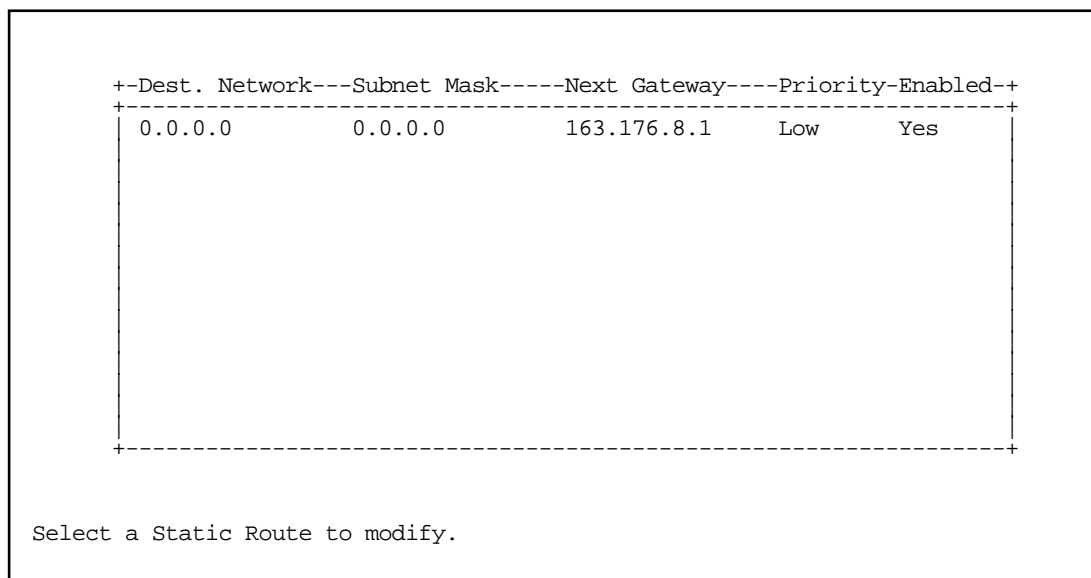

The table has the following columns:

**Dest. Network:** The network IP address of the destination network.

**Subnet Mask:** The subnet mask associated with the destination network.

**Next Gateway:** The IP address of the router that will be used to reach the destination network.

**Priority:** An indication of whether the Netopia 4541/4542 will use the static route when it conflicts with information received from RIP packets.

**Enabled:** An indication of whether the static route should be installed in the IP routing table.

To return to the Static Routes screen, press Escape.

### Adding a static route

To add a new static route, select **Add Static Route** in the Static Routes screen. The Add Static Route screen will appear.

Add Static Route

Static Route Enabled:	Yes
Destination Network IP Address:	0.0.0.0
Destination Network Subnet Mask:	0.0.0.0
Next Gateway IP Address:	0.0.0.0
Route Priority...	High
Advertise Route Via RIP:	No

ADD STATIC ROUTE NOW                      CANCEL

Configure a new Static Route in this Screen.

- To install the static route in the IP routing table, select **Static Route Enabled** and toggle it to **Yes**. To remove the static route from the IP routing table, select **Static Route Enabled** and toggle it to **No**.
- Be sure to read the rules on the installation of static routes in the IP routing table. See [“Rules of static route installation” on page 8-9](#).
- Select **Destination Network IP Address** and enter the network IP address of the destination network.
- Select **Destination Network Subnet Mask** and enter the subnet mask used by the destination network.
- Select **Next Gateway IP Address** and enter the IP address for the router that the Netopia 4541/4542 will use to reach the destination network. This router does not necessarily have to be part of the destination network, but it must at least know where to forward packets destined for that network.
- Select **Route Priority** and choose **High** or **Low**. High means that the static route takes precedence over RIP



information; Low means that the RIP information takes precedence over the static route.

- If the static route conflicts with a connection profile, the connection profile will always take precedence.
- To make sure that the static route is known only to the Netopia 4541/4542, select **Advertise Route Via RIP** and toggle it to **No**. To allow other RIP-capable routers to know about the static route, select **Advertise Route Via RIP** and toggle it to **Yes**. When Advertise Route Via RIP is toggled to **Yes**, a new item called **RIP Metric** appears below **Advertise Route Via RIP**.

With RIP Metric you set the number of routers, from 1 to 15, between the sending router and the destination router. The maximum number of routers on a packet's route is 15. Setting **RIP Metric** to **1** means that a route can involve 15 routers, while setting it to **15** means a route can only involve one router.

- Select **ADD STATIC ROUTE NOW** to save the new static route, or select **CANCEL** to discard it and return to the Static Routes screen.
- Up to 32 static routes can be created, but one is always reserved for the default gateway, which is configured using either Easy Setup or the IP Setup screen in system configuration.

### *Modifying a static route*

To modify a static route, in the Static Routes screen select **Display/Change Static Route** to display a table of static routes.

Select a static route from the table and go to the Change Static Route screen. The parameters in this screen are the same as the ones in the Add Static Route screen (see ["Adding a static route" on page 8-8](#)).

### *Deleting a static route*

To delete a static route, in the Static Routes screen select **Delete Static Route** to display a table of static routes. Select a static route from the table and press Return to delete it. To exit the table without deleting the selected static route, press Escape.

### *Rules of static route installation*

The Netopia 4541/4542 applies certain rules before installing enabled static routes in the IP routing table. An enabled static route will not be installed in the IP routing table if any of the following conditions are true:

- The static route's **Next Gateway IP Address** matches an IP address in the range of IP addresses being distributed by DHCP.
- The static route's **Next Gateway IP Address** is determined to be unreachable by the Netopia 4541/4542.
- The static route's route information conflicts with a connection profile's route information.
- The connection profile associated with the static route has a disabled dial-on-demand setting, and there is no current connection using that connection profile.

A static route that is already installed in the IP routing table will be removed if any of the conditions listed above become true for that static route. However, an enabled static route is automatically reinstalled once the conditions listed above are no longer true for that static route.

## IP Address Servicing

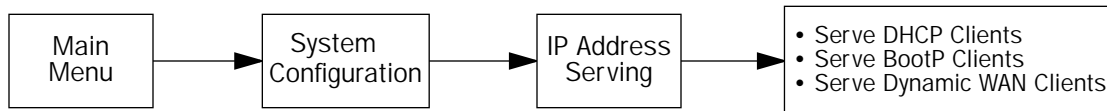

In addition to being a router, the Netopia 4541/4542 is also an IP address server. There are three protocols it can use to distribute IP addresses.

- The first, called Dynamic Host Configuration Protocol (DHCP), is widely supported on PC networks, as well as Apple Macintosh computers using Open Transport and computers using the UNIX operating system. Addresses assigned via DHCP are “leased” or allocated for a short period of time; if a lease is not renewed, the address becomes available for use by another computer. DHCP also allows most of the IP parameters for a computer to be configured by the DHCP server, simplifying setup of each machine.
- The second, called BOOTP (also known as Bootstrap Protocol), is the predecessor to DHCP and allows older IP hosts to obtain most of the information that a DHCP client would obtain. However, in contrast, BOOTP address assignments are “permanent” since there is no lease renewal mechanism in BOOTP.
- The third protocol, called Dynamic WAN, is part of the PPP/MP suite of wide area protocols used for WAN connections. It allows remote terminal adapters and NAT-enabled routers to be assigned a temporary IP address for the duration of their connection.

Since no two hosts can use the same IP address at the same time, make sure that the addresses distributed by the Netopia 4541/4542 and those that are manually configured are not the same. Each method of distribution must have its own exclusive range of addresses to draw from.

Go to the System Configuration screen. Select **IP Address Servicing** and press Return. The IP Address Servicing screen will appear.

```

                                IP Address Servicing
                                +-----+
                                |         |
IP Address Servicing Mode...  | Disabled |
                                | DHCP Server |
Number of Client IP Addresses: | DHCP Relay Agent |
1st Client Address:          |         |
Client Default Gateway...    | 192.168.1.1 |
                                +-----+

Serve DHCP Clients:          Yes
DHCP Lease Time (Hours):    1
DHCP NetBIOS Options...

Serve BOOTP Clients:        Yes

Serve Dynamic WAN Clients    Yes
  
```

Follow these steps to configure IP Address Serving:

- If you enabled IP Address Serving, then DHCP, BootP clients and Dynamic WAN clients are automatically enabled.
- The **IP Address Serving Mode** pop-up menu allows you to choose the way in which the Netopia 4541/4542 will serve IP addresses. The device can act as either a DHCP Server or a DHCP Relay Agent. (See “[DHCP Relay Agent](#)” on page 8-23 for more information.) In most cases, you will use the device to serve its own pool of IP addresses, hence DHCP Server is the default. Address serving can also be disabled.
- Select **Number of Client IP Addresses** and enter the total number of contiguous IP addresses that the Netopia 4541/4542 will distribute to the client machines on your local area network. Twelve-user models are limited to twelve IP addresses.

In the screen example shown above, five Client IP addresses have been allocated.

- Select **1st Client Address** and enter the first client IP address that you will allocate to your first client machine. For instance, on your local area network you may want to first figure out which machines are going to be allocated specific static IP addresses so that you can determine the pool of IP addresses that you will be serving addresses from via DHCP, BootP, and/or Dynamic WAN.

**Example:** Your ISP has given your Netopia 4541/4542 the IP address 192.168.6.137, with a subnet mask of 255.255.255.248. The subnet mask allocated will give you six IP addresses to use when connecting to the ISP over the Internet. Your address range will be from **.137-.143**. In this example you would enter **192.168.6.138** as the 1st Client Address, since the router itself must have an IP address.

- To enable DHCP, select **Serve DHCP Clients** and toggle it to **Yes**. DHCP serving is automatic when IP Address Serving is enabled.
- The default DHCP Lease time is one hour. This may be unnecessarily brief in your network environment. Consequently, the DHCP lease time is now configurable. The **DHCP Lease Time (Hours)** setting allows you to modify the router’s default lease time of one hour. You can enter any number up to and including 168 hours (one week) for the DHCP lease.

If you have configured multiple Ethernet IP subnets, the appearance of the IP Address Serving screen is altered slightly:

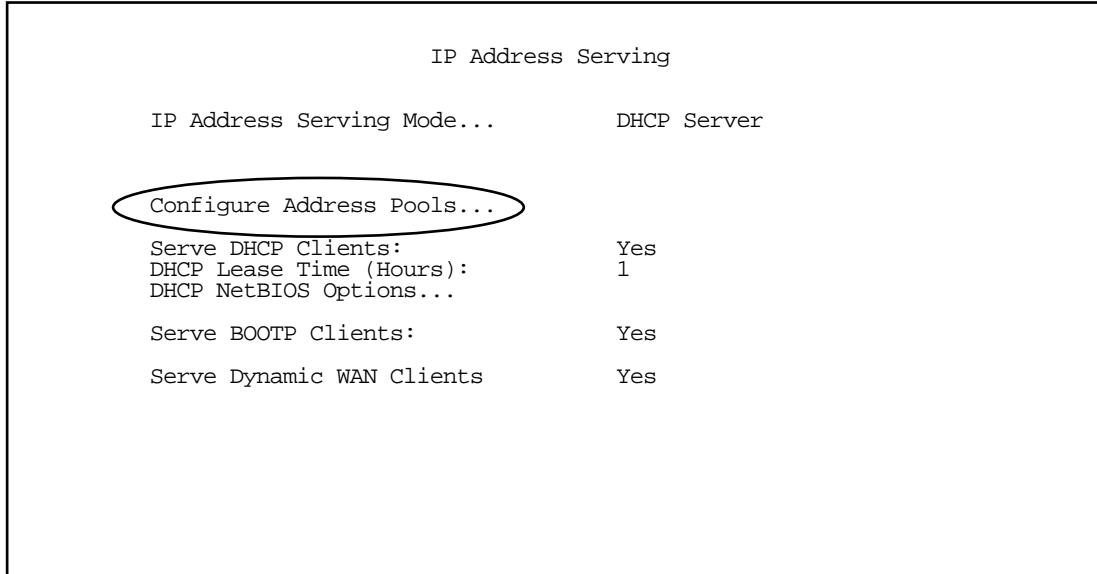

Three menu items are hidden, and **Configure Address Pools...** appears instead. If you select **Configure Address Pools...** you will be taken to the IP Address Pools screen that allows you to configure an address serving pool for each of the configured Ethernet IP subnets. See ["IP Address Pools"](#) on page 8-13.

## IP Address Pools

The IP Address Pools screen allows you to configure a separate IP address serving pool for each of up to eight configured Ethernet IP subnets:

IP Address Pools			
Subnet (# host addrs)	1st Client Addr	Clients	Client Gateway
192.128.117.0 (253)	192.128.117.196	16	192.128.117.162
192.129.117.0 (253)	192.129.117.110	8	192.129.117.4

This screen consists of between two and eight rows of four columns each. There are exactly as many rows as there are Ethernet IP subnets configured on the IP Subnets screen.

- The **Subnet (# host addrs)** column is non-selectable and non-editable. It indicates the network address of the Ethernet IP subnet for which an address pool is being configured and the number of host addresses available on the subnet. The network address is equal to the router's IP address on the subnet bitwise-ANDed with the subnet mask. The host address count is equal to the subnet size minus three, since one address is reserved for the network address, one for the subnet broadcast address, and one for the router's interface address on the subnet.

You can edit the remaining columns in each row.

- The **1st Client Addr** and **Clients** columns allow you to specify the base and extent of the address serving pool for a particular subnet. Entering 0.0.0.0 for the first client address or 0 for the number of clients indicates that no addresses will be served from the corresponding Ethernet IP subnet.
- The Client Gateway column allows you to specify the default gateway address that will be provided to clients served an address from the corresponding pool. The value defaults to the Netopia 4541/4542's IP address on the corresponding subnet (or the Netopia 4541/4542's default gateway, if that gateway is located on the subnet in question). You can override the value by entering any address that is part of the subnet.

DHCP, BootP, and dynamic WAN clients may receive an address from any one of the address serving pools configured on this screen.

Numerous factors influence the choice of served address. It is difficult to specify the address that will be served to a particular client in all circumstances. However, when the address server has been configured, and the clients involved have no prior address serving interactions, the Netopia 4541/4542 will generally serve the first unused address from the first address pool with an available address. The Netopia 4541/4542 starts from the pool on the first row and continues to the pool on the last row of this screen.

Once the address server and/or the clients have participated in address serving transactions, different rules apply:

- When requesting an address, a client will often suggest an address to be assigned, such as the one it was last served. The Netopia 4541/4542 will attempt to honor this request if the address is available. The client stores this address in non-volatile storage, for example, on disk, and the specific storage method/location differs depending on the client operating system.
- When requesting an address, a client may provide a client identifier, or, if it does not, the Netopia 4541/4542 may construct a pseudo-client identifier for the client. When the client subsequently requests an address, the Netopia 4541/4542 will attempt to serve the address previously associated with the pseudo-client identifier. This is normally the last address served to the client.
- Otherwise, the Netopia will select the least-recently used available address, starting from the first address in the first pool and ending with the last address in the last pool.

Note: The address serving pools on this screen are tied to the IP subnets configured on the IP Subnets screen. Changes to the IP Subnets screen may affect this screen. In particular, deleting a subnet on the IP Subnets screen will delete the corresponding address serving pool, if any, on this screen.

## DHCP NetBIOS Options

If your network uses NetBIOS, you can enable the Netopia 4541/4542 to use DHCP to distribute NetBIOS information.

NetBIOS stands for Network Basic Input/Output System. It is a layer of software originally developed by IBM and Sytek to link a network operating system with specific hardware. NetBIOS has been adopted as an industry standard. It offers LAN applications a variety of “hooks” to carry out inter-application communications and data transfer. Essentially, NetBIOS is a way for application programs to talk to the network. To run an application that works with NetBIOS, a non-IBM network operating system or network interface card must offer a NetBIOS emulator. Many vendors either provide a version of NetBIOS to interface with their hardware or emulate its transport layer communications services in their network products. A NetBIOS emulator is a program provided by NetWare clients that allow workstations to run applications that support IBM's NetBIOS calls.

- Select **DHCP NetBios Options** and press Return. The DHCP NetBIOS Options screen appears.

DHCP NetBios Options

Serve NetBios Type:	Yes
NetBios Type...	Type B
Serve NetBios Scope:	No
NetBios Scope:	
Serve NetBios Name Server:	No
NetBios Name Server IP Addr:	0.0.0.0

Configure DHCP-served NetBIOS options here.

- To serve DHCP clients with the type of NetBIOS used on your network, select **Serve NetBios Type** and toggle it to **Yes**.

- From the **NetBios Type** pop-up menu, select the type of NetBIOS used on your network.

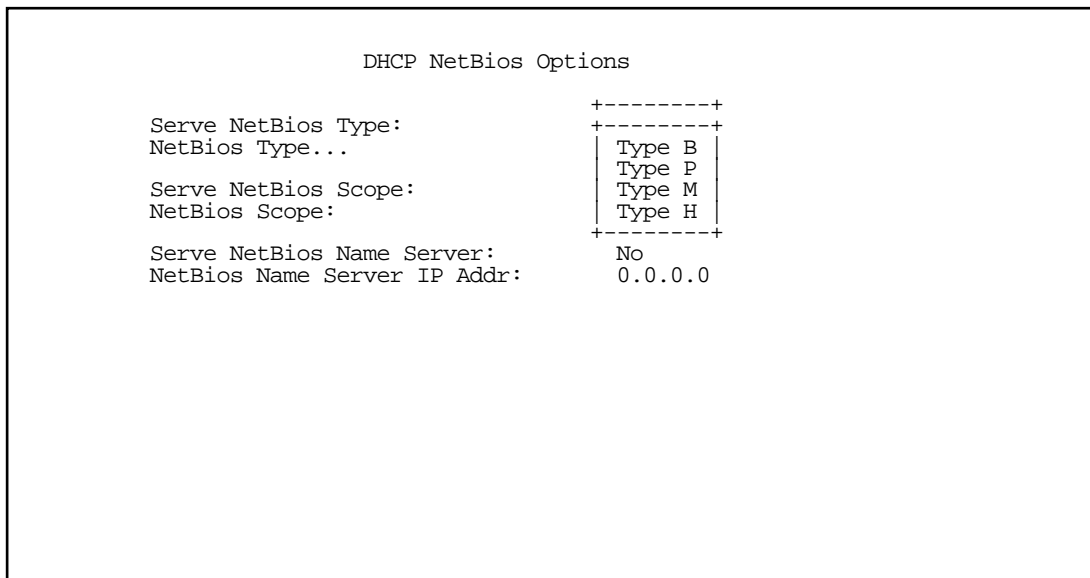

- To serve DHCP clients with the NetBIOS scope, select **Serve NetBios Scope** and toggle it to **Yes**. Select **NetBios Scope** and enter the scope.
- To serve DHCP clients with the IP address of a NetBIOS name server, select **Serve NetBIOS Name Server** and toggle it to **Yes**. Select **NetBios Name Server IP Addr** and enter the IP address for the NetBIOS name server. You are now finished setting up DHCP NetBIOS Options. To return to the IP Address Serving screen, press Escape.
- To enable BootP's address serving capability, select **Serve BOOTP Clients** and toggle to **Yes**.

**Note:** Addresses assigned through BootP are permanently allocated from the IP Address Serving pool until you release them. To release these addresses, navigate back to the Main Menu, then Statistics & Logs, Served IP Addresses, and Lease Management.

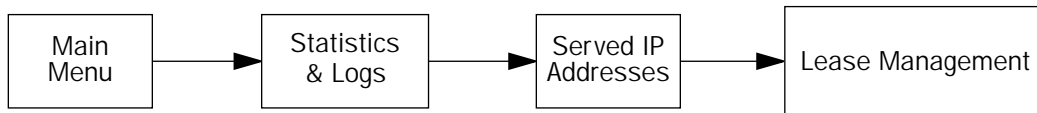



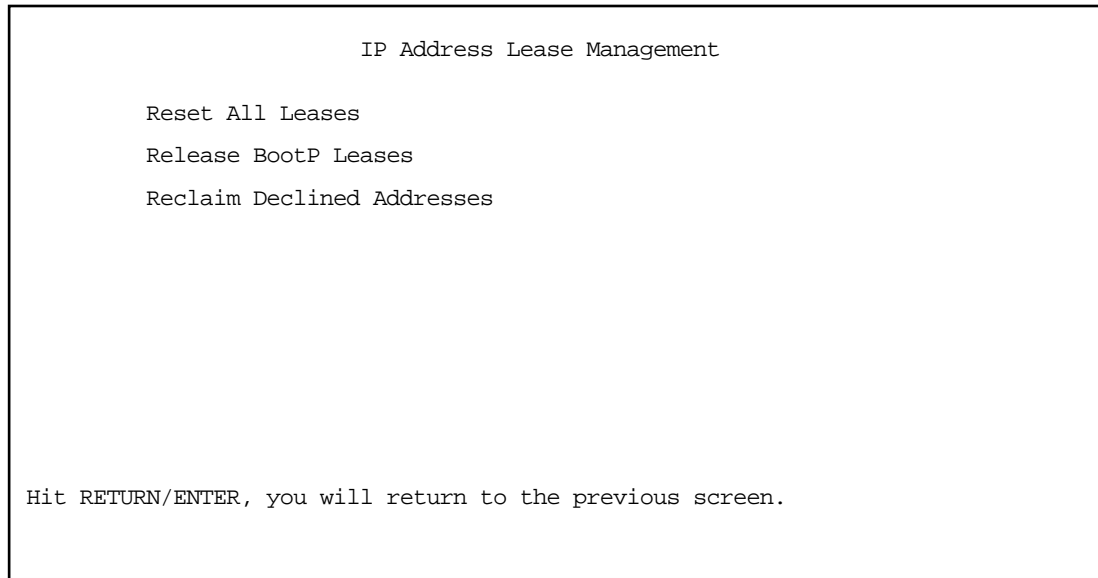

Select **Release BootP Leases** and press Return.

- Back in IP Address Serving, the Serve Dynamic WAN Clients toggle

---

## *More Address Serving Options*

The Netopia 4541/4542 includes a number of enhancements in the built-in DHCP IP address server. These enhancements include:

- The ability to exclude one or more IP addresses from the address serving pool so the addresses will not be served to clients.
- The ability to reserve a particular IP address for a client with a particular Ethernet MAC address.
- The ability to view the host name associated with a client to which the router has leased an IP address.
- The ability for the router's Ethernet IP address(es) to overlap the DHCP address serving pool(s).
- The ability to serve as a DHCP Relay Agent.

The Netopia 4541/4542 supports reserving an IP address only for a type 1 client identifier (i.e., an Ethernet hardware address). It does not support reserving an IP address for an arbitrary client identifier. (For more information on client identifiers, see RFC 2131, section 9.14.)

## Configuring the IP Address Server options

To access the enhanced DHCP server functions, from the Main Menu navigate to **Statistics & Logs** and then **Served IP Addresses**.



The following example shows the Served IP Addresses screen after three clients have leased IP addresses. The first client did not provide a Host Name in its DHCP messages; the second and third clients did.

Served IP Addresses			
-IP Address-----	Type----	Expires--	Host Name/Client Identifier-----
-----SCROLL UP-----			
192.168.1.100			
192.168.1.101			
192.168.1.102			
192.168.1.103	DHCP	00:59	EN: 00-00-C5-70-00-04
192.168.1.104	DHCP	00:59	Bill's Pentium
192.168.1.105	DHCP	00:45	Steve's Power Mac
192.168.1.106			
192.168.1.107			
192.168.1.108			
192.168.1.109			
192.168.1.110			
192.168.1.111			
192.168.1.112			
192.168.1.113			
-----SCROLL DOWN-----			
Lease Management...			

The rightmost column displays the host name supplied by the client if one was provided; otherwise it displays the client identifier. (If a host name is displayed, the client identifier is still accessible in a Details pop-up menu. See below.)

Note: The server does not query the client for its host name. Macintosh computers running versions of MacOS prior to MacOS version 8.5 (OT 2.0.1, TCP/IP 2.0.1) do not supply a host name option in their DHCP messages, so no host name will appear in the Served IP Addresses list.

You can select the entries in the Served IP Addresses screen. Use the up and down arrow keys to move the selection to one of the entries in the list of served IP addresses.

```

                                Served IP Addresses
-----IP Address-----Type----Expires--Host Name/Client Identifier-----
-----SCROLL UP-----
192.168.1.100
192.168.1.101
192.168.1.102
192.168.1.103
192.168.1.104
192.168.1.105
192.168.1.106      +-----+
192.168.1.107      +-----+
192.168.1.108      | Details...   | Barr's XPi 120
192.168.1.109      | Exclude      |
192.168.1.110      | Release      |
192.168.1.111      | Reserve...   |
192.168.1.112      +-----+
192.168.1.113
-----SCROLL DOWN-----
Lease Management...

```

Once you select an entry, pressing Return displays an action pop-up menu that lists operations that can be performed on that entry. Possible operations are **Details...**, **Exclude**, **Include**, **Release**, and **Reserve...** The action popup is context-sensitive and lists only those operations that apply to the selected IP address in its current lease state.

- **Details...** is displayed if the entry is associated with both a host name and a client identifier.

Selecting **Details...** displays a pop-up menu that provides additional information associated with the IP address. The pop-up menu includes the IP address as well as the host name and client identifier supplied by the client to which the address is leased.

```

                                Served IP Addresses
-----IP Address-----Type----Expires--Host Name/Client Identifier-----
-----SCROLL UP-----
192.168.1.100
192.168.1.101
+-----+
|
| IP Address is 192.168.1.108
| Host Name is  Barr's XPi 120
| Client ID is  EN: 00-00-c5-45-89-ef
|
|                                OK
|
+-----+
192.168.1.111   | Reserve... |
192.168.1.112   +-----+
192.168.1.113
-----SCROLL DOWN-----
Lease Management...

```

- **Exclude** is displayed if the entry is not already excluded.

Selecting **Exclude** excludes the IP address from the address serving pool so the address will not be served to a client. If the IP address is currently leased to or reserved for a client, you will be presented with a warning dialog asking you to confirm the operation.

```

Served IP Addresses
-----
-IP Address-----Type----Expires--Host Name/Client Identifier-----
-----SCROLL UP-----
192.168.1.100
192.168.1.101
192.1+-----+
192.1+-----+
192.1|
192.1| You are about to make changes that will affect an address
192.1| that is currently in use. Are you sure you want to do this?
192.1|
192.1|          CANCEL                      OK
192.1|
192.1+-----+
192.168.1.111 | Reserve... |
192.168.1.112 |-----+
192.168.1.113
-----SCROLL DOWN-----
Lease Management...

```

- **Include** is displayed if the entry is either excluded or declined.

An IP address is marked declined when a client to whom the DHCP server offers the address declines the address. A client declines an address if it determines that a leased address is already in use by another device.

Selecting **Include** restores the selected IP address to the address serving pool so that the IP address is once again eligible to be served to a client.

- **Release** is displayed if the entry is currently offered, leased, or reserved.

Selecting **Release** puts the selected entry in the available state. You will be presented with a warning dialog asking you to confirm the operation since the IP address is in use. There is no mechanism to notify the client to whom the address is leased that the lease has been terminated. Thus, the client will continue to use the address until the next time it attempts to renew its lease. In the interim, the server may lease the same IP address to a different client, thereby creating an address conflict. For this reason, releasing an address that is actively being used by a client is generally not recommended.

- **Reserve...** is displayed if the entry is available, declined, excluded, leased, offered, or reserved.

Reserving an IP address for a client with a particular Ethernet MAC address guarantees that a client with the specified MAC address will be offered or leased the specified IP address. Moreover, it prevents the specified IP address from being offered or leased to any other client.

Selecting **Reserve...** displays a pop-up dialog box that displays the IP address and editable item in which you can enter an Ethernet MAC address. The pop-up dialog box includes **OK** and **CANCEL** buttons for confirming or cancelling the operation. If the IP address is currently offered or leased to, or reserved for, a client, you will be presented with a warning dialog asking you to confirm the operation. Reserving an IP address guarantees that the IP address will only be leased.

```

                                Served IP Addresses
-----IP Address-----Type----Expires--Host Name/Client Identifier-----
-----SCROLL UP-----
192.168.1.100
192.168.1.101
192.168.1.102
192.168.1.103
192.168.1.104
192.168.1.105
192.168.1.106
192.168.1.107
192.168.1.108
192.168.1.109
192.168.1.110
192.168.1.111
192.168.1.112
192.168.1.113
-----SCROLL DOWN-----
Lease Management...

```

+-----+  
 | IP Address is 192.168.1.108  
 | MAC Address: 00-00-c5-45-89-ef  
 | CANCEL           OK  
 +-----+

The router's Ethernet IP address(es) will be automatically excluded from the address serving pool(s) on startup. Entries in the served IP address list corresponding to the router's Ethernet IP address(es) that have been automatically excluded on startup are not selectable.

```

                                Served IP Addresses
-----IP Address-----Type----Expires--Host Name/Client Identifier-----
-----SCROLL UP-----
192.168.1.1      Excluded for the router's IP address
192.168.1.2      Excluded
192.168.1.3      DHCP      00:24   Barr's XPi 120
192.168.1.4
192.168.1.5
192.168.1.6
192.168.1.7
192.168.1.8
192.168.1.9
192.168.1.10
192.168.1.11
192.168.1.12
192.168.1.13
192.168.1.14
-----SCROLL DOWN-----
Lease Management...

Hit RETURN/ENTER for available operations.

```

---

## DHCP Relay Agent

The Netopia 4541/4542 offers DHCP Relay Agent functionality, as defined in RFC1542. A DHCP relay agent is a computer system or a router that is configured to forward DHCP requests from clients on the LAN to a remote DHCP server, and to pass the replies back to the requesting client systems.

When a DHCP client starts up, it has no IP address, nor does it know the IP address of a DHCP server. Therefore, it uses an IP broadcast to communicate with one or more DHCP servers. These broadcasts are normally limited to the network segment on which the client is located, and do not pass through routers such as the Netopia Router. If the Netopia Router is configured to act as a DHCP server, it will assign the client an address from an address pool configured locally in the Netopia Router and respond to the client's request itself.

However, if the Netopia Router is configured to act as a DHCP relay agent, it does not satisfy the DHCP request itself, but instead forwards the request to one or more remote DHCP servers. These servers process the request, assign an address from an address pool configured on the remote server, and forward the response back to the Netopia Router for delivery back to the client. The agent then sends the response to the client on behalf of the DHCP server. This process is transparent to the client, which doesn't know that it is communicating through an intermediary rather than directly to a local server. Using DHCP relay, it is possible to centralize the configuration information for the host computers at many remote sites at a single location, easing the burden of administering configuration management for remote sites.

To configure the Netopia Router to act as a DHCP relay agent, from the Main Menu navigate to the System Configuration menu.

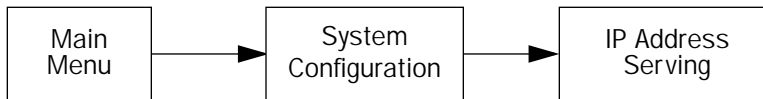

Select **IP Address Serving** and press Return. The IP Address Serving screen appears.

```

                                IP Address Serving
                                +-----+
                                |         |
IP Address Serving Mode...    | Disabled |
                                | DHCP Server |
Number of Client IP Addresses: | DHCP Relay Agent |
1st Client Address:          |         |
Client Default Gateway...    | 192.168.1.1 |
                                +-----+

Serve DHCP Clients:           Yes
DHCP NetBIOS Options...

Serve BOOTP Clients:         Yes
  
```

Select **IP Address Serving Mode**. The pop-up menu offers the choices of **Disabled**, **DHCP Server** (the default), and **DHCP Relay Agent**.

If you select DHCP Relay Agent and press Return, the screen changes as shown below.

```

                                IP Address Serving

IP Address Serving Mode...    DHCP Relay Agent

Relay Server #1:             10.1.1.1
Relay Server #2:             20.1.1.1
Relay Server #3:             30.1.1.1

Configure Address Serving (DHCP, BOOTP, etc.) here.
  
```

Now you can enter the IP address(es) of your remote DHCP server(s), such as might be located in your company's corporate headquarters. Each time you enter an IP address and press Return, an additional field appears. You can enter up to four DHCP server addresses.

In the example above, DHCP requests from clients on the LAN will be relayed to the DHCP servers at IP addresses 10.1.1.1, 20.1.1.1, and 30.1.1.1.



Note: The remote DHCP server(s) to which the Netopia Router is relaying DHCP requests must be capable of servicing relayed requests. Not all DHCP servers support this feature. For example, the DHCP server in the Netopia Router does *not*.

The DHCP server(s) to which the Netopia Router is relaying DHCP requests must be configured with one or more address pools that are within the Netopia Router's primary Ethernet LAN subnet. (There is no mechanism for DHCP clients to receive an address on a secondary subnet via a relayed DHCP request.)

---

## Connection Profiles

Since you will probably only have a single connection to your ISP over the DSL link, you may not need to create multiple connection profiles. Additional profiles may be useful for creating VPNs.

Connection Profiles define the line and networking protocols necessary for the router to make a remote connection. A connection profile is like an address book entry describing how the router is to get to a remote site, or how to recognize and authenticate a remote user connecting to the router. To create a new Connection Profile, you navigate to the WAN Configuration screen from the Main Menu, and select **Add Connection Profile**.

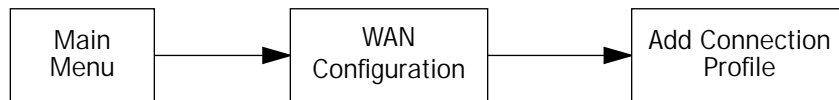

The Add Connection Profile screen appears.

Add Connection Profile

Profile Name:	Profile 1
Profile Enabled:	Yes
Data Link Encapsulation...	PPP
Data Link Options...	
IP Profile Parameters...	
<div style="display: flex; justify-content: space-around; margin-top: 20px;"> <span>COMMIT</span> <span>CANCEL</span> </div>	

Configure a new Conn. Profile. Finished? COMMIT or CANCEL to exit.

On a Netopia 4541/4542 you can add up to 15 more connection profiles, for a total of 16, although only one can be used at a time, unless you are using VPNs.

1. Select **Profile Name** and enter a name for this connection profile. It can be any name you wish. For example: the name of your ISP.

2. Toggle the **Profile Enabled** value to **Yes** or **No**. The default is Yes.
3. Select **IP Profile Parameters** and press Return. The IP Profile Parameters screen appears.

IP Profile Parameters

Address Translation Enabled:	Yes
IP Addressing...	Numbered
NAT Map List...	Easy-PAT List
NAT Server List...	Easy-Servers
Local WAN IP Address:	0.0.0.0
Local WAN IP Mask:	0.0.0.0
Remote IP Address:	0.0.0.0
Remote IP Mask:	0.0.0.0
Filter Set...	
Remove Filter Set	
RIP Profile Options...	

Configure IP requirements for a remote network connection here.

4. Toggle or enter any IP parameters you require and return to the Add Connection Profile screen by pressing Escape. For more information on NAT, see ["Multiple Network Address Translation," beginning on page 9-1](#). The Local WAN IP Address is displayed for numbered or NAT profiles. The Local WAN IP Mask is displayed for numbered profiles. The Remote IP Address and Remote IP Mask are displayed for unnumbered profiles.

5. Select **ADD PROFILE NOW** and press Return. Your new connection profile will be added.

If you want to view the connection profiles in your router, return to the WAN Configuration screen, and select **Display/Change Connection Profile**. The list of connection profiles is displayed in a scrolling pop-up screen.

```

                                WAN Configuration
+--Profile Name-----IP Address-----+
+-----+-----+
Easy Setup Profile           127.0.0.2
Profile 1                     0.0.0.0
+-----+-----+
on:      Yes

Up/Down Arrow Keys to select, ESC to dismiss, Return/Enter to Edit.
```



## Chapter 9

# Multiple Network Address Translation

The Netopia 4541/4542 offers advanced Multiple Network Address Translation functionality.

You should read this chapter completely before attempting to configure any of the advanced NAT features.

This chapter covers the following topics:

- [Overview on page 9-1](#)
- [MultiNAT Configuration on page 9-5](#)
- [Easy Setup Profile configuration on page 9-6](#)
- [Server Lists and Dynamic NAT configuration on page 9-6](#)
- [Adding Server Lists on page 9-14](#)
- [Binding Map Lists and Server Lists on page 9-20](#)
- [NAT Associations on page 9-24](#)
- [MultiNAT Configuration Example on page 9-26](#)

---

### Overview

NAT (Network Address Translation) is a means of mapping one or more IP addresses and/or IP service ports into different values. This *mapping* serves two functions:

- It allows the addresses of many computers on a LAN to be represented to the public Internet by only one or a few addresses, saving you money.
- It can be used as a security feature by obscuring the true addresses of important machines from potential hackers on the Internet.

To help you understand some of the concepts discussed here, it may be helpful to introduce some NAT terminology.

The term *mapping* refers to rules that associate one or more private addresses on the Netopia Router's LAN to one or more public addresses on the Netopia Router's WAN interface (typically the Internet).

The terms *private* and *internal* refer to addresses on the Netopia Router's LAN. These addresses are considered private because they are protected or obscured by NAT and cannot be directly accessed from the WAN (or Internet) side of the Netopia Router unless specifically configured otherwise.

The terms *public* and *external* refer to the WAN (or Internet) side of the Netopia Router.

### Features

MultiNAT features can be divided into several categories that can be used simultaneously in different combinations on a per-Connection Profile basis.

The following is a general description of these features:

### *Port Address Translation*

The simplest form of classic Network Address Translation is *PAT* (Port Address Translation). *PAT* allows a group of computers on a LAN, such as might be found in a home or small office, to share a single Internet connection using one IP address. The computers on the LAN can surf the Web, read e-mail, download files, etc., but their individual IP addresses are never exposed to the public network. Instead, a single IP address acts as the source IP address of traffic originating from the LAN. The Netopia Router allows you to define multiple *PAT* mappings, which can be individually mapped to different public IP addresses. This offers more control over the access permitted to users on the LAN.

A limitation of *PAT* is that communication must be initiated from the internal network. A user on the external side cannot access a machine behind a *PAT* connection. A *PAT* enhancement introduced in firmware version 4.4 is the ability to define multiple *PAT* mappings. Each of these can optionally map to a section or *range* of IP addresses of the internal network. *PAT* mapping allows only internal users to initiate traffic flow between the internal and external networks.

### *Server lists*

*Server lists*, previously known as exported services, make it possible to provide access from the public network to hosts on the LAN. *Server lists* allow you to define particular services, such as Web, ftp, or e-mail, which are available via a public IP address. You define the type of service you would like to make available and the internal IP address to which you would like to provide access. You may also define a specific public IP address to use for this service if you want to use an IP other than the WAN IP address of the Netopia Router.

### *Static mapping*

If you want to host your own Website or provide other Internet services to the public, you need more than classic NAT. The reason is noted under Port Address Translation above – external users cannot initiate traffic to computers on your LAN because external users can never see the real addresses of the computers on your LAN. If you want users outside your LAN to have access, for example, to a Web or FTP server that you host, you need to make a public representation of the real IP addresses of those servers.

*Static mappings* are a way to make one or more private IP addresses fully accessible from the public network via corresponding public IP addresses. Some applications may negotiate multiple TCP connections in the process of communication, which often does not work with traditional *PAT*. *Static mapping* offers the ability to use these applications through NAT. Each private IP address is mapped, on a one-to-one basis, to a public IP address that can be accessed from the Internet or public network. As with *PAT* mappings, you may have multiple *static mappings* to map a range of private IP addresses to a range of public IP addresses if desired.

### *Dynamic mapping*

*Dynamic mapping*, often referred to as many-to-few, offers an extension to the advantages provided by *static mapping*. Instead of requiring a one-to-one association of public addresses and private addresses, as is required in *static mapping*, *dynamic mapping* uses a group of public IP addresses to dynamically allocate *static mappings* to private hosts that are communicating with the public network. If a host on the private network initiates a connection to the Internet, for example, the Netopia Router automatically sets up a one-to-one mapping of that host's private IP address to one of the public IP addresses allocated to be used for *Dynamic NAT*. As long as this host is communicating with the Internet, it will be able to use that address. When traffic from that host ceases, and no traffic is passed from that host for five minutes, the public address is made available again for other private hosts to use as necessary.

When addresses are returned to the group of available addresses, they are returned to the head of the group, being the most recently used. If that same host requests a connection an hour later, and the same public address is still available, then it will be mapped to the same private host. If a new host, which has not previously requested a connection, initiates a connection it is allocated the last, or oldest, public address available.

Dynamic NAT is a way of sharing a range of public, or exterior, NAT addresses among one or more *groups* of private, or interior, hosts. This is intended to provide superior support for applications that traditionally have difficulty communicating through NAT. Dynamic NAT is intended to provide functionality beyond many-to-one and one-to-one translation. Netopia's NAT implementation makes it possible to have a static mapping of one public address to one private address, thus allowing applications such as NetMeeting to work by assuring that any traffic sent back to the source IP address is forwarded through to the internal machine.

Static one-to-one mapping works well if you have enough IP addresses for all the workstations on your LAN. If you do not, Dynamic NAT allows machines to make full use of the publicly routable IP addresses provided by the ISP as necessary, on demand. When these public IP addresses are no longer being used by a particular workstation, they are returned to a pool of available addresses for other workstations to use.

A common example is a DSL customer's application. Most DSL ISPs only provide customers with a few IP addresses for use on their network. For networks with more than four or five machines it is usually mandatory to use NAT. A customer may have 15 workstations on the LAN, all of which need Internet access. The customer is only provided five IP addresses by their ISP. The customer has eight hosts, which only need to use email and have Web access, but another seven hosts, which use NetMeeting to communicate with clients once or twice a day. NetMeeting will not work unless a static one-to-one mapping exists for the machine running NetMeeting to use for communication. The customer does not have enough IP addresses to create a one-to-one mapping for each of the seven users. This is where dynamic NAT applies.

The customer can configure four of these addresses to be used for Dynamic NAT. The fifth address is then used for the eight other machines that do not need one-to-one mappings. As each machine configured to use addresses from the dynamic pool tries to connect to the Internet it is allocated a public IP address to use temporarily. Once the communication has been terminated, that IP address is freed for one of the other six hosts to use.

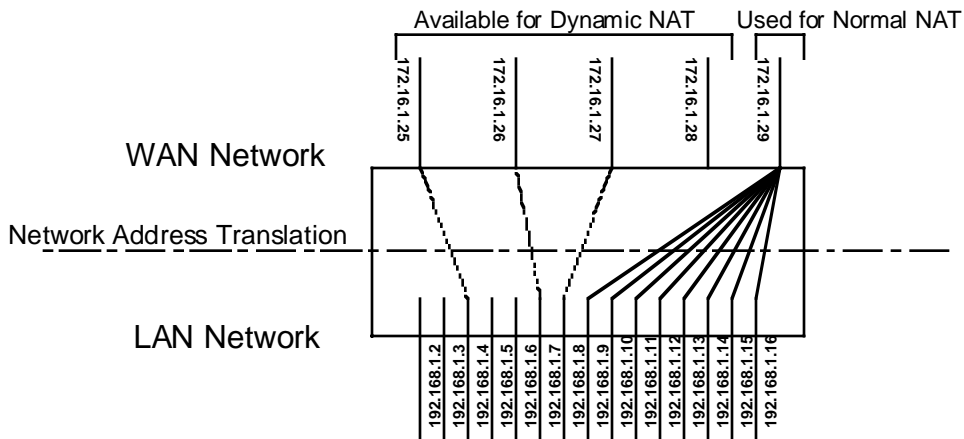

## 9-4 User's Reference Guide

Exterior addresses are allocated to internal hosts on a demand, or as-needed, basis and then made available when traffic from that host ceases. Once an internal host has been allocated an address, it will use that address for all traffic. Five minutes after all traffic ceases – no pings, all TCP connections closed, no DNS requests, etc. – the address is put at the head of an *available* list. If an interior host needs an exterior address an hour later, and the previously used address is still available, it will acquire the same address. If an interior host that has not previously been allocated an exterior address needs one, it will be allocated the last, hence the oldest, exterior address on the available list.

All NAT configurations are *rule-based*. This means that traffic passed through NAT from either the public or the private network is compared to the rules and mappings configured in the Netopia Router in a particular order. The first rule that applies to the traffic being initiated is used.

For example, if a connection is initiated from the public network and is destined for a public IP address configured on the Netopia Router, the following comparisons are made in this order.

1. The Netopia Router first checks its internal NAT cache to see if the data is part of a previously initiated connection, if not...
2. The Netopia Router checks the configured server lists to see if this traffic is intended to be forwarded to an internal host based on the type of service.
3. The Netopia Router then checks to see if there is a static, dynamic, or PAT mapping for the public IP address that the connection is being initiated to.
4. The Netopia Router answers the request itself if the data is destined for the Netopia's WAN interface IP address. Otherwise the data is discarded.

### Complex maps

Map lists and server lists are completely independent of each other. A Connection Profile can use one or the other or both.

MultiNAT allows complex mapping and requires more complex configuration than in earlier firmware versions. Multiple mapped interior subnets are supported, and the rules for mapping each of the subnets may be different. The figure below illustrates a possible multiNAT configuration.

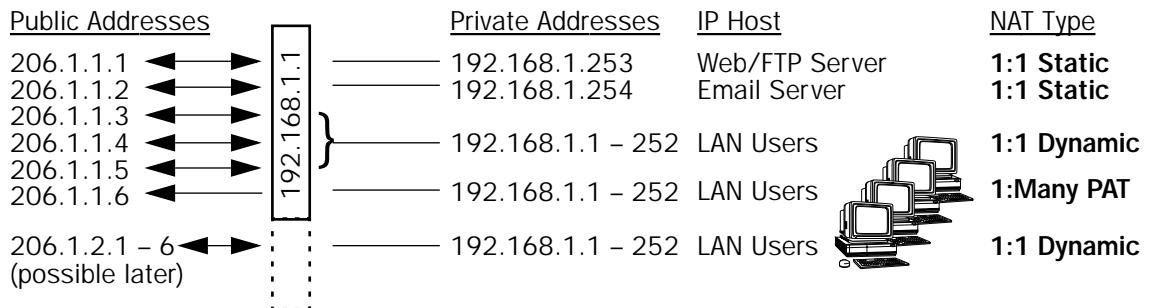



In order to support this type of mapping, you define two address ranges. First, you define a public range which contains the first and last public address to be used and the way in which these addresses should be used (PAT, static, or dynamic). You then configure an address map which defines the private IP address or addresses to be used and which public range they should be mapped to. You add the address map to the list of address maps which are configured, creating a map list. The mappings in the map list are order-dependent and are compared in order from the top of the list to the bottom. If a particular resource is not available, subordinate mappings can be defined that will redirect traffic.

## Supported traffic

MultiNat supports the following IP protocols:

- PAT: TCP/UDP traffic which does not carry source or destination IP addresses or ports in the data stream (i.e., HTTP, Telnet, 'r' commands, tftp, NFS, NTP, SMTP, NNTP, etc.).
- Static NAT: All IP protocol traffic which does not carry or otherwise rely on the source or destination IP addresses in the data stream.
- Dynamic NAT: All IP protocol traffic which does not carry or otherwise rely on the source or destination IP addresses in the data stream.

---

## MultiNAT Configuration

You configure the MultiNAT features through the console menu:

- For a simple 1-to-many NAT configuration (classic NAT or PAT), use the [Easy Setup Profile configuration](#), described below.
- For the more advanced features, such as server lists and dynamic NAT, follow the instructions in:
  - [IP setup](#), described on [page 9-7](#)
  - [IP profile parameters](#), described on [page 9-20](#)

## Easy Setup Profile configuration

The screen below is an example. Depending on the type of router you are using, fields displayed in this screen may vary.

```

Connection Profile 1: Easy Setup Profile

Connection Profile Name:          Easy Setup Profile

Address Translation Enabled:      Yes
IP Addressing...                 Numbered

Local WAN IP Address:            0.0.0.0
Local WAN IP Mask:              255.255.255.0
Remote IP Address:              127.0.0.2
Remote IP Mask:                 255.255.255.255

PPP Authentication...           PAP
Send User Name:                 tonyf
Send Password:                 *****

PREVIOUS SCREEN                 NEXT SCREEN

Return/Enter brings you to next screen.

```

The **Local WAN IP Address** is used to configure a NAT public address range consisting of the Local WAN IP Address and all its ports. The public address map list is named *Easy-PAT List* and the port map list is named *Easy-Servers*.

The two map lists, Easy-PAT List and Easy-Servers, are created by default and NAT configuration becomes effective. This will map all your private addresses (0.0.0.0 through 255.255.255.255) to your public address. These map lists are bound to the Easy Setup Profile. See [Binding Map Lists and Server Lists on page 9-20](#).

This is all you need to do if you want to continue to use a single PAT, or 1-to-many, NAT configuration.

## Server Lists and Dynamic NAT configuration

You use the advanced NAT feature sets by first defining a series of mapping rules and then grouping them into a *list*. There are two kinds of lists -- *map lists*, made up of dynamic, PAT and static mapping rules, and *server lists*, a list of internal services to be presented to the external world. Creating these lists is a four-step process:

1. **Define the public range** of addresses that external computers should use to get to the NAT internal machines. These are the addresses that someone on the Internet would see.
2. **Create a List name** that will act as a rule or server holder.
3. **Create a map or rule** that specifies the internal range of NATed addresses and the external range they are to be associated with.
4. **Associate the Map or Server List to your WAN interface** via a Connection Profile or the Default Profile.

The three NAT features all operate completely independently of each other, although they can be used simultaneously on the same Connection Profile.

You can configure a simple 1-to-many PAT (often referred to simply as NAT) mapping using Easy Setup. More complex setups require configuration using the **Network Address Translation** item on the IP Setup screen.

An example MultiNAT configuration at the end of this chapter describes some applications for these features. See the [MultiNAT Configuration Example](#) on page 9-26.

In order to configure the router to make servers on your LAN visible to the Internet, you use advanced features in the System Configuration screens, described in [IP setup](#).

## IP setup

To access the NAT configuration screens, from the Main Menu navigate to IP Setup:

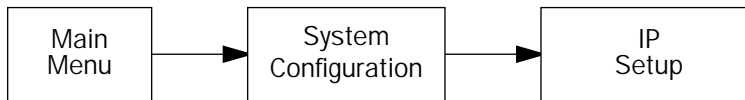

```

                                IP Setup

Ethernet IP Address:              192.168.1.1
Ethernet Subnet Mask:           255.255.255.0
Define Additional Subnets...

Default IP Gateway:              127.0.0.2

Primary Domain Name Server:      0.0.0.0
Secondary Domain Name Server:    0.0.0.0
Domain Name:                     isp.com

Receive RIP...                   Both
Transmit RIP...                  Off

Static Routes...                 IP Address Serving...
Network Address Translation (NAT)...

Set up the basic IP attributes of your Netopia in this screen.
  
```

Select **Network Address Translation (NAT)** and press Return.

The Network Address Translation screen appears.

```
Network Address Translation

Add Public Range...
Show/Change Public Range...
Delete Public Range...

Add Map List...
Show/Change Map List...
Delete Map List...

Add Server List...
Show/Change Server List...
Delete Server List...

NAT Associations...

Return/Enter to configure IP Address redirection.
```

**Public Range** defines an external address range and indicates what type of mapping to apply when using this range. The types of mapping available are *dynamic*, *static* and *pat*.

**Map Lists** define collections of mapping rules. A rule maps interior range addresses to exterior range addresses by the mapping techniques defined in the map list.

**Server Lists** bind internal IP addresses and ports to external IP addresses and ports so that connections initiated from the outside can access an interior server.

### *NAT rules*

The following rules apply to assigning NAT ranges and server lists:

- Static public address ranges must not overlap other static, PAT, public addresses, or the public address assigned to the router's WAN interface.
- A PAT public address must not overlap any static address ranges. It may be the same as another PAT address or server list address, but the port range must not overlap.

You configure the ranges of exterior addresses by first adding public ranges.

Select **Add Public Range** and press Return.

The Add NAT Public Range screen appears.

Add NAT Public Range	
Range Name:	my_first_range
Type...	pat
Public Address:	206.1.1.6
First Public Port:	49152
Last Public Port:	65535
ADD NAT PUBLIC RANGE	CANCEL

- Select **Range Name** and give a descriptive name to this range.
- Select **Type** and from the pop-up menu, assign its type. Options are **static**, **dynamic**, or **pat** (the default).
  - If you choose **pat** as the range type, select **Public Address** and enter the exterior IP address in the range you want to assign. Select **First** and **Last Public Port** and enter the first and last exterior ports in the range. These are the ports that will be used for traffic initiated from the private LAN to the outside world.

Note: For PAT map lists and server lists, if you use the Public Address 0.0.0.0, the list will acquire its public IP address from the WAN IP address specified by your WAN IP configuration in the Connection Profile. If that is a static IP address, then the PAT map list and server lists will acquire that address. If it is a negotiated IP address, such as may be assigned via DHCP or PPP, the PAT map list and server lists will acquire that address each time it is negotiated.

- If you choose **dynamic** as the range type, a new menu item, **First Public Address**, becomes visible. Select **First Public Address** and enter the first exterior IP address in the range you want to assign. Select **Last Public Address** and enter an IP address at the end of the range.
- If you choose **static** as the range type, a new menu item, **First Public Address**, becomes visible. Select **First Public Address** and enter the first exterior IP address in the range you want to assign. Select **Last Public Address** and enter an IP address at the end of the range.
- Select **ADD NAT PUBLIC RANGE** and press Return. The range will be added to your list and you will be returned to the Network Address Translation screen.

Once the public ranges have been assigned, the next step is to bind interior addresses to them. Because these bindings occur in ordered lists, called *map lists*, you must first define the list, then add mappings to it.

From the Network Address Translation screen select **Add Map List** and press Return.

The Add NAT Map List screen appears.

```

                                Add NAT Map List

Map List Name:                    my_map

Add Map...
    
```

- Select **Map List Name** and enter a descriptive name for this map list. A new menu item, **Add Map**, appears.
- Select **Add Map** and press Return. The Add NAT Map screen appears.

```

                                Add NAT Map ("my_map")

First Private Address:            192.168.1.1
Last Private Address:            192.168.1.254

Use NAT Public Range...

                                ADD NAT MAP                                CANCEL
    
```

- Select **First** and **Last Private Address** and enter the first and last interior IP addresses you want to assign to this mapping.
- Select **Use NAT Public Range** and press Return. A screen appears displaying the public ranges you have defined.

```

                                Add NAT Map ("my_map")
+--Public Address Range-----Type-----Name-----+
| 0.0.0.0          --          pat      Easy-PAT
| 206.1.1.6        --          pat      my_first_range ← Select
| 206.1.1.1        206.1.1.2    static  my_second_range
| <<NEW RANGE...>>
+-----+

```

Up/Down Arrow Keys to select, ESC to cancel, Return/Enter to Delete.

- From the list of public ranges you defined, select the one that you want to map to the interior range for this mapping and press Return.

If none of your preconfigured ranges are suitable for this mapping, you can select <<**NEW RANGE**>> and create a new range. If you choose <<**NEW RANGE**>>, the Add NAT Public Range screen displays and you can create a new public range to be used by this map. See [Add NAT Public Range on page 9-9](#).

- The Add NAT Map screen now displays the range you have assigned.

```

                                Add NAT Map ("my_map")

First Private Address:          192.168.1.1
Last Private Address:          192.168.1.254

Use NAT Public Range...        my_first_range
  Public Range Type is:        pat
  Public Range Start Address is: 206.1.1.6

ADD NAT MAP                      CANCEL

```

- Select **ADD NAT MAP** and press Return. Your mapping is added to your map list.

## Modifying map lists

You can make changes to an existing map list after you have created it. Since there may be more than one map list you must select which one you are modifying.

From the Network Address Translation screen select **Show/Change Map List** and press Return.

- Select the map list you want to modify from the pop-up menu.

```

Network Address Translation
+-NAT Map List Name--+
+-----+
Add Out  Easy-PAT List
Show/Ch  my_map
Delete
Add Map
Show/Ch
Delete
Add Ser
Show/Ch
Delete
NAT Ass
+-----+

```

Up/Down Arrow Keys to select, ESC to dismiss, Return/Enter to Edit.

The Show/Change NAT Map List screen appears.

```

Show/Change NAT Map List

Map List Name:          my_map

Add Map...
Show/Change Maps...
Delete Map...

```



- **Add Map** allows you to add a new map to the map list.
- **Show/Change Maps** allows you to modify the individual maps within the list.
- **Delete Map** allows you to delete a map from the list.

Selecting **Show/Change Maps** or **Delete Map** displays the same pop-up menu.

```

                                Show/Change NAT Map List
+---Private Address Range-----Type---Public Address Range-----+
| 192.168.1.1    192.168.1.254  pat    206.1.1.6    --
| 192.168.1.253  192.168.1.254  static 206.1.1.1    206.1.1.2
| 192.168.1.1    192.168.1.252  dynamic 206.1.1.3    206.1.1.5
+-----+-----+-----+-----+

```

Scroll to the map you want to modify using the arrow keys and press Return.

The Change NAT Map screen appears.

```

                                Change NAT Map ("my_map")

First Private Address:          192.168.1.253
Last Private Address:          192.168.1.254

Use NAT Public Range...       my_second_range
Public Range Type is:         static
Public Range Start Address is: 206.1.1.1
Public Range End Address is:  206.1.1.2

CHANGE NAT MAP                  CANCEL

```

Make any modifications you need and then select **CHANGE NAT MAP** and press Return. Your changes will become effective and you will be returned to the Show/Change NAT Map List screen.

---

## Adding Server Lists

Server lists, also known as Exports, are handled similarly to map lists. If you want to make a particular server's port accessible (and it isn't accessible through other means, such as a static mapping), you must create a server list.

Select **Add Server List** from the Network Address Translation screen.

The Add NAT Server List screen appears.

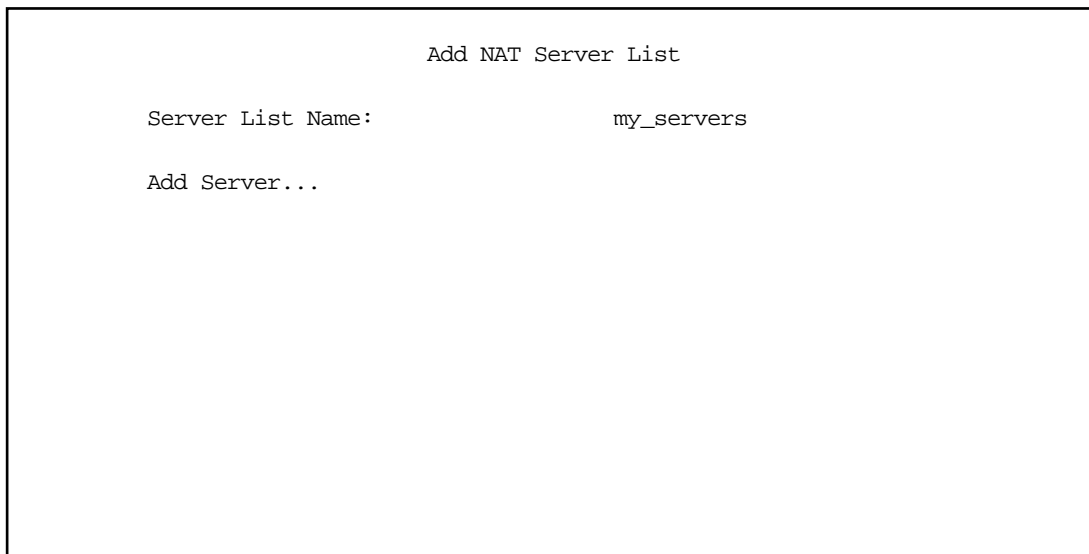

Add NAT Server List

Server List Name:

Add Server...

- Select **Server List Name** and type in a descriptive name. A new menu item, **Add Server**, appears.

- Select **Add Server** and press Return. The Add NAT Server screen appears.

```

                                Add NAT Server ("my_servers")

Service...
Server Private IP Address:      192.168.1.45
Public IP Address:              206.1.1.1

                                ADD NAT SERVER                CANCEL

```

- Select **Service** and press Return. A pop-up menu appears listing a selection of commonly exported services.

```

                                Add NAT Server ("my_servers")
                                +-Type-----Port(s)-----+
Service...
Server Private IP Address:
Public IP Address:
                                ftp      21
                                telnet   23
                                smtp     25
                                tftp     69
                                gopher   70
                                finger    79
                                www-http  80
                                pop2     109
                                pop3     110
                                snmp     161 - 162
                                timbuktu 407
                                pptp    1723
                                irc      6665 - 6669
                                Other...
                                +-----+
                                ADD NAT SERVER                CANCEL

```

- Choose the service you want to export and press Return.

You can choose a preconfigured service from the list, or define your own by selecting **Other**. If you select **Other**, a screen is displayed that allows you to enter the port number range for your customized service.

Other Exported Port	
First Port Number (1..65535):	31337
Last Port Number (1..65535):	31337
OK	CANCEL

- Enter the **First** and **Last Port Number** between ports 1 and 65535. Select **OK** and press Return. You will be returned to the Add NAT Server screen.

- Enter the **Server Private IP Address** of the server whose service you are exporting.

Since MultiNAT permits the mapping of multiple private IP addresses to multiple public IP addresses, your ISP or corporate site's router must be configured such that it knows that your multiple public addresses are accessible via your router.

If you want to use static mappings to map internal servers to public addresses, your ISP or corporate site's router must also be configured for static routes to these public addresses on the Netopia Router.

- Enter the **Public IP Address** to which you are exporting the service.

Note: For PAT map lists and server lists, if you use the Public Address 0.0.0.0, the list will acquire its public IP address from the WAN IP address specified by your WAN IP configuration in the Connection Profile. If that is a static IP address, then the PAT map list and server lists will acquire that address. If it is a negotiated IP address, such as may be assigned via DHCP or PPP, the PAT map list and server lists will acquire that address each time it is negotiated.

- Select **ADD NAT SERVER** and press Return. The server will be added to your server list and you will be returned to the Add NAT Server List screen.

Note: CUSeeMe (or other services that listen on specific ports) through MultiNat works as it did for non-MultiNat releases prior to version 4.4. In order to use **CUSeeMe** through the Netopia Router, you must export the ports 7648 and 7649. In MultiNat, you may use a port range export. Without the export, CUSeeMe will fail to work. This is true unless a static mapping is in place for the host using CUSeeMe. In that case no server list entry is necessary.

## Modifying server lists

Once a server list exists, you can select it for modification or deletion.

- Select **Show/Change Server List** from the Network Address Translation screen.
- Select the Server List Name you want to modify from the pop-up menu and press Return.

```

Network Address Translation
+-NAT Server List Name--+
+-----+
A | my_servers          | ..
S |                    |
D |                    |
+-----+
A |                    |
S |                    |
D |                    |
+-----+
A |                    |
S |                    |
D |                    |
+-----+

Up/Down Arrow Keys to select, ESC to dismiss, Return/Enter to Edit.

```

The Show/Change NAT Server List screen appears.

```

Show/Change NAT Server List

Server List Name:          my_servers

Add Server...
Show/Change Server...
Delete Server...

```

- Selecting **Show/Change Server** or **Delete Server** displays the same pop-up menu.

```

          Show/Change NAT Server List
    +-Private Address--Public Address---Port-----+
    |-----+-----+-----+
Se | 192.168.1.254   206.1.1.6       smtp
   | 192.168.1.254   206.1.1.5       smtp
   | 192.168.1.254   206.1.1.4       smtp
Ad | 192.168.1.254   206.1.1.3       smtp
   | 192.168.1.254   206.1.1.1       smtp
Sh |
De |
   |-----+-----+-----+
Up/Down Arrow Keys to select, ESC to dismiss, Return/Enter to Edit.

```

Select any server from the list and press Return. The Change NAT Server screen appears.

```

          Change NAT Server ("My Exports")

Service...                smtp
Server Private IP Address: 192.168.1.254
Public IP Address:        206.1.1.1

CHANGE NAT SERVER          CANCEL

```

You can make changes to the server's service and port or internal or external address.

Select **CHANGE NAT SERVER** and press Return. Your changes take effect and you are returned to the Show/Change NAT Server List screen.

## Deleting a server

To delete a server from the list, select **Delete Server** from the Show/Change NAT Server List menu and press Return.

A pop-up menu lists your configured servers. Select the one you want to delete and press Return. A dialog box asks you to confirm your choice.

```

                                Show/Change NAT Server List
+--Internal Address-External Address--Port-----+
|
Se | 192.168.1.254   206.1.1.6       smtp
   | 19+-----+
   | 19+-----+
Ad  | Are you sure you want to delete this Server?
Sh  |          CANCEL                CONTINUE
De  |
   |
   +-----+
+-----+

```

Choose **CONTINUE** and press Return. The server is deleted from the list.

## Binding Map Lists and Server Lists

Once you have created your map lists and server lists, for most Netopia Router models you must bind them to a profile, either a Connection Profile or the Default Profile. You do this in one of the following screens:

- the [IP profile parameters](#) screen (see below) of the Connection Profile configuration menu
- the [IP Parameters \(WAN Default Profile\)](#) screen (see [page 9-22](#)) of the Default Profile configuration menu
- the [Binding Map Lists and Server Lists](#) screen (see [page 9-20](#))

### IP profile parameters

To bind a map list to a Connection Profile, from the Main Menu go to the WAN Configuration screen then the Display/Change Connection Profile screen. From the pop-up menu list of your Connection Profiles, choose the one you want to bind your map list to. Select **IP Profile Parameters** and press Return.

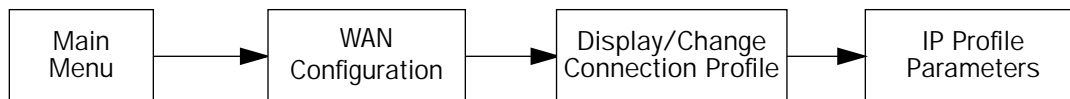

The IP Profile Parameters screen appears.

```

IP Profile Parameters

Address Translation Enabled:      Yes
IP Addressing...                 Unnumbered

NAT Map List...                  Easy-PAT List
NAT Server List...              Easy-Servers

Local WAN IP Address:           206.1.1.6
Local WAN IP Mask:              0.0.0.0
Remote IP Address:              127.0.0.2
Remote IP Mask:                 255.255.255.255

Filter Set...                    Basic Firewall
Remove Filter Set

RIP Profile Options...

Configure IP requirements for a remote network connection here.
  
```



- Select **NAT Map List** and press Return. A pop-up menu displays a list of your defined map lists.

```

                                IP Profile Parameters
                                +--NAT Map List Name--+
                                +-----+
Address Trans  Easy-PAT          s
IP Addressing my_map           mbered
                                <<None>>
NAT Map List. sy PAT
NAT Server Li
Local WAN IP
Remote IP Add 7.0.0.2
Remote IP Mas 5.255.255.255
Filter Set... tBIOS Filter
Remove Filter
Receive RIP:  th
                                +-----+

Up/Down Arrow Keys to select, ESC to dismiss, Return/Enter to Edit.

```

- Select the map list you want to bind to this Connection Profile and press Return. The map list you selected will now be bound to this Connection Profile.
- Select **NAT Server List** and press Return. A pop-up menu displays a list of your defined server lists.

```

                                IP Profile Parameters
                                +--NAT Server List Name--+
                                +-----+
Address Trans  Easy-Servers      s
IP Addressing my_servers       mbered
                                <<None>>
NAT Map List. sy PAT
NAT Server Li
Local WAN IP   0.0.0
Local WAN IP   0.0.0
Remote IP Add  7.0.0.2
Remote IP Mas  5.255.255.255
Filter Set...  tBIOS Filter
Remove Filter
Receive RIP:   th
                                +-----+

Up/Down Arrow Keys to select, ESC to dismiss, Return/Enter to Edit.

```

- Select the server list you want to bind to this Connection Profile and press Return. The server list you selected will now be bound to this Connection Profile.

Note: There is no interdependency between NAT and IP Addressing. Also, the Local WAN IP Address and Mask fields' visibility are dependent only on the IP Addressing type.

## IP Parameters (WAN Default Profile)

The Netopia 4541/4542 using RFC 1483 supports a WAN default profile that permits several parameters to be configured without an explicitly configured Connection Profile.

The procedure is similar to the procedure to bind map lists and server lists to a Connection Profile.

From the Main Menu go to the WAN Configuration screen, then the Default Profile screen. Select **IP Parameters** and press Return.

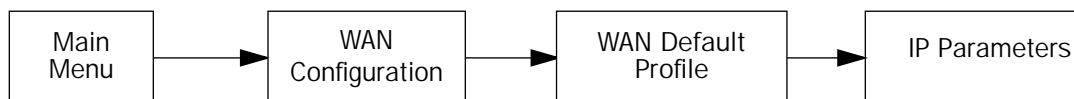

The IP Parameters (Default Profile) screen appears.

```

IP Parameters (Default Profile)

Address Translation Enabled:      Yes
NAT Map List...                  Easy-PAT List
NAT Server List...              Easy-Servers

Filter Set (Firewall)...
Remove Filter Set

Receive RIP:                      Both

Return/Enter to select <among/between> ...
  
```

- Toggle **Address Translation Enabled** to Yes.

- Select **NAT Map List** and press Return. A pop-up menu displays a list of your defined map lists.

```

IP Parameters (Default Profile)
+--NAT Map List Name----+
+-----+
Easy-PAT List
my_map
<<None>>
Address Trans s
NAT Map List.
NAT Server Li
Filter Set (F
Remove Filter
Receive RIP: th
+-----+

Up/Down Arrow Keys to select, ESC to dismiss, Return/Enter to Edit.

```

- Select the map list you want to bind to the default profile and press Return. The map list you selected will now be bound to the default profile.
- Select **NAT Server List** and press Return. A pop-up menu displays a list of your defined server lists.

```

IP Parameters (Default Profile)
+--NAT Server List Name--+
+-----+
Easy-Servers
my_servers
<<None>>
Address Trans s
NAT Map List.
NAT Server Li _first_map
Filter Set (F
Remove Filter
Receive RIP: th
+-----+

Up/Down Arrow Keys to select, ESC to dismiss, Return/Enter to Edit.

```

- Select the server list you want to bind to the default profile and press Return. The server list you selected will now be bound to the default profile.

Note: There is no interdependency between NAT and IP Addressing. Also, the Local WAN IP Address and Mask fields' visibility are dependent only on the IP Addressing type.

## NAT Associations

Configuration of map and server lists alone is not sufficient to enable NAT for a WAN connection because map and server lists must be linked to a profile that controls the WAN interface. This can be a Connection Profile, a WAN Ethernet interface, a default profile, or a default answer profile. Once you have configured your map and server lists, you may want to reassign them to different interface-controlling profiles, for example, Connection Profiles. To permit easy access to this IP Setup functionality, you can use the NAT Associations screen.

You access the NAT Associations screen from the Network Address Translation screen.

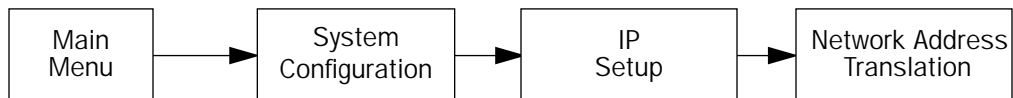

Select **NAT Associations** and press Return. The NAT Associations screen appears.

NAT Associations			
Profile/Interface Name-----	Nat?	Map List Name-----	Server List Name
Default Answer Profile	On	my_first_map	my_servers
Easy Setup Profile	On	Easy-PAT	my_servers
Profile 01	On	my_second_map	my_servers
Profile 02	On	my_first_map	my_server_list
Profile 03	On	<<None>>	<<None>>

- You can toggle **NAT? On** or **Off** for each Profile/Interface name. You do this by navigating to the **NAT?** field associated with each profile using the arrow keys. Toggle NAT on or off by using the Tab key.
- You can reassign any of your map lists or server lists to any of the Profile/Interfaces. You do this by navigating to the **Map List Name** or **Server List Name** field associated with each profile using the arrow

keys. Select the item by pressing Return to display a pop-up menu of all of your configured lists.

NAT Associations		
Profile/Interface Name-----	Nat	+NAT Map List Name--+
Easy Setup Profile	On	Easy-PAT List
Profile 01	On	my_first_map
Profile 02	On	my_second_map
Profile 03	On	my_map
Profile 04	On	<<None>>
Default Answer Profile	On	my_servers

Server List Name

my\_servers  
my\_servers  
my\_server\_list  
<<None>>  
<<None>>

Up/Down Arrow Keys to select, ESC to dismiss, Return/Enter to Edit.

- Select the list name you want to assign and press Return again. Your selection will then be associated with the corresponding profile or interface.

## MultiNAT Configuration Example

To help you understand a typical MultiNAT configuration, this section describes an example of the type of configuration you may want to implement on your site. The values shown are for example purposes only. *Make your own appropriate substitutions.*

A typical DSL service from an ISP might include five user addresses. Without PAT, you might be able to attach only five IP hosts. Using simple 1-to-many PAT you can connect more than five devices, but use only one of your addresses. Using multiNAT you can make full use of the address range. The example assumes the following range of addresses offered by a typical ISP:

Local WAN IP address:	206.1.1.6
Local WAN subnet mask:	255.255.255.248
Remote IP address:	206.1.1.254
Default gateway:	206.1.1.254

Public IP addresses assigned by the ISP are 206.1.1.1 through 206.1.1.6 (255.255.255.248 subnet mask).

Your internal devices have IP addresses of 192.168.1.1 through 192.168.1.254 (255.255.255.0 subnet mask).

Netopia Router's address is:	192.168.1.1
Web server's address is:	192.168.1.253
Mail server's address is:	192.168.1.254
FTP server's address is:	192.168.1.253

In this example you will statically map the first five public IP addresses (206.1.1.1 - 206.1.1.5) to the first five corresponding private IP addresses (192.168.1.1 - 192.168.1.5). You will use these 1-to-1 mapped addresses to give your servers "real" addresses. You will then map 206.1.1.6 to the remaining private IP addresses (192.168.1.6 - 192.168.1.254) using PAT.

The configuration process is as follows:

From the Main Menu go to the Easy Setup and then the Connection Profile screen.



Enter your ISP-supplied values as shown below.

```

          Connection Profile 1: Easy Setup Profile

Connection Profile Name:          Easy Setup Profile

Address Translation Enabled:      Yes
IP Addressing...                 Numbered

Local WAN IP Address:            206.1.1.6
Local WAN IP Mask:               255.255.255.248

PREVIOUS SCREEN                  NEXT SCREEN

Enter a subnet mask in decimal and dot form (xxx.xxx.xxx.xxx).
Enter basic information about your WAN connection with this screen.

```

Select **NEXT SCREEN** and press Return.

Your IP values are shown here.

```

          IP Easy Setup

Ethernet IP Address:              192.168.1.1
Ethernet Subnet Mask:            255.255.255.0

Domain Name:                     ISP.net
Primary Domain Name Server:      173.166.101.1
Secondary Domain Name Server:    173.166.102.1

Default IP Gateway:              206.1.1.254
IP Address Serving:              On

Number of Client IP Addresses:    20
1st Client Address:              192.168.1.2

PREVIOUS SCREEN                  NEXT SCREEN

Set up the basic IP & IPX attributes of your Netopia in this screen.

```

Then navigate to the Network Address Translation (NAT) screen.

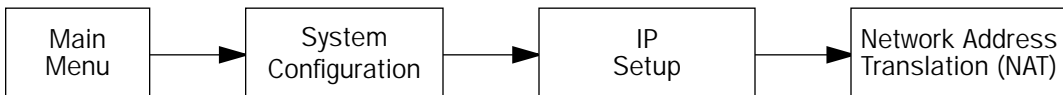

Select **Show/Change Public Range**, then **Easy-PAT Range**, and press Return. Enter the value your ISP assigned for your public address (206.1.1.6, in this example). Toggle **Type** to pat. Your public address is then mapped to the remaining private IP addresses using PAT. (If you were not using the Easy-PAT Range and Easy-PAT List that are created by default by using Easy Setup, you would have to *define* a public range and map list. For the purpose of this example you can just *alter* this range and list.)

Change NAT Public Range	
Range Name:	Easy-PAT Range
Type...	pat
Public Address:	206.1.1.6
First Public Port:	49152
Last Public Port:	65535
CHANGE NAT PUBLIC RANGE	CANCEL

Select **CHANGE NAT PUBLIC RANGE** and press Return. This returns you to the Network Address Translation screen.

Select **Add Public Range** and press Return. Type a name for this static range, as shown below. Enter the first and last public addresses your ISP assigned in their respective fields as shown. The first five public IP addresses (206.1.1.1 - 206.1.1.5, in this example) are statically mapped to the first five corresponding private IP addresses (192.168.1.1 - 192.168.1.5).

Add NAT Public Range	
Range Name:	Static Range
Type...	static
First Public Address:	206.1.1.1
Last Public Address:	206.1.1.5
ADD NAT PUBLIC RANGE	CANCEL

Return/Enter to commit changes.



Select **ADD NAT PUBLIC RANGE** and press Return. You are returned to the Network Address Translation screen.

Next, select **Show/Change Map List** and choose **Easy-PAT List**. Select **Add Map**. The **Add NAT Map** screen appears. (Now the name *Easy-PAT List* is a misnomer since it has a static map included in its list.) Enter in 192.168.1.1 for the **First Private Address** and 192.168.1.5 for the **Last Private Address**.

```

                                Add NAT Map ("Easy-PAT List")

First Private Address:           192.168.1.1
Last Private Address:           192.168.1.5

Use NAT Public Range...

ADD NAT MAP                      CANCEL

```

Select **Use NAT Public Range** and from the pop-up menu choose **Static Range**. Select **ADD NAT MAP** and press Return.

This will statically map the first five public IP addresses to the first five corresponding private IP addresses and will map 206.1.1.6 to the remaining private IP addresses using PAT.

### Notes on the example

The Easy-Map List and the Easy-PAT List are attached to any new Connection Profile by default. If you want to use this NAT configuration on a previously defined Connection Profile then you need to *bind* the Map List to the profile. You do this through either the NAT Associations screen or the profile's configuration screens.

The PAT part of this example setup will allow any user on the Netopia Router's LAN with an IP address in the range of 192.168.1.6 through 192.168.1.254 to *initiate* traffic flow to the outside world (for example, the Internet). No one on the Internet would be able to initiate a conversation with them.

The Static mapping part of this example will allow any of the machines in the range of addresses from 192.168.1.1 through 192.168.1.5 to communicate with the outside world as if they were at the addresses 206.1.1.1 through 206.1.1.5, respectively. It also allows any machine on the Internet to access any service (port) on any of these five machines.

You may decide this poses a security risk. You may decide that anyone can have complete access to your FTP server, but not to your router, and only limited access to the desired services (ports) on the Web and Mail servers.

To make these changes, first limit the range of remapped addresses on the Static Map and then edit the default server list called Easy-Servers.

- First, navigate to the **Show/Change Map List** screen, select **Easy-PAT List** and then **Show/Change Maps**. Choose the **Static Map** you created and change the **First Private Address** from 192.168.1.1 to 192.168.1.4. Now the router, Web, and Mail servers' IP addresses are no longer included in the range of static mappings and are therefore no longer accessible to the outside world. Users on the Internet will not be able to Telnet, Web, SNMP, or ping to them. It is best also to navigate to the public range screen and change the **Static Range** to go from 206.1.1.5.
- Next, navigate to **Show/Change Server List** and select **Easy-Servers** and then **Add Server**. You should export both the Web (www-http) and Mail (smtp) ports to one of the now free public addresses. Select **Service...** and from the resulting pop-up menu select **www-http**. In the resulting screen enter your Web server's address, 192.168.1.2, and the public address, for example, 206.1.1.2, and then select **ADD NAT SERVER**. Now return to **Add Server**, choose the **smtp** port and enter 192.168.1.3, your Mail server's IP address for the **Server Private IP Address**. You can decide if you want to present both your Web and Mail services as being on the same public address, 206.1.1.2, or if you prefer to have your Mail server appear to be at a different IP address, 206.1.1.3. For the sake of this example, alias both services to 206.1.1.2.

Now, as before, the PAT configuration will allow any user on the Netopia Router's LAN with an IP address in the range of 192.168.1.6 through 192.168.1.254 to initiate traffic flow to the Internet. Someone at the FTP server can access the Internet and the Internet can access all services of the FTP machine as if it were at 206.1.1.5. The router cannot directly communicate with the outside world. The only communication between the Web server and the Internet is through port 80, the Web port, as if the server were located on a machine at IP address 206.1.1.2. Similarly, the only communication with the Mail server is through port 25, the SMTP port, as if it were located at IP address 206.1.1.2

## Chapter 10

# Virtual Private Networks (VPNs)

The Netopia 4541/4542 offers IPsec, PPTP, and ATMP tunneling support for Virtual Private Networks (VPN).

The following topics are covered in this chapter:

- "Overview" on page 10-1
- "About PPTP Tunnels" on page 10-3
- "About IPsec Tunnels" on page 10-7
- "About ATMP Tunnels" on page 10-12
- "Encryption Support" on page 10-15
- "ATMP/PPTP Default Profile" on page 10-16
- "VPN QuickView" on page 10-17
- "Dial-Up Networking for VPN" on page 10-18
- "Installing the VPN Client" on page 10-21
- "Allowing VPNs through a Firewall" on page 10-23

---

### Overview

When you make a long distance telephone call from your home to a relative far away, you are creating a private network. You can hold a conversation, and exchange information about the happenings on opposite sides of the state, or the continent, that you are mutually interested in. When your next door neighbor picks up the phone to call her daughter at college, at the same time you are talking to your relatives, your calls don't overlap, but each is separate and private. Neither house has a direct wire to the places they call. Both share the same lines on the telephone poles (or underground) on the street.

These calls are *virtual private networks*. *Virtual*, because they appear to be direct connections between the calling and answering parties, even though they travel over the public wires and switches of the phone company; *private*, because neither pair of calling and answering parties interacts with the other; and *networks*, because they exchange information.

Computers can do the same thing; it's called Virtual Private Networks (VPNs). Equipped with a Netopia 4541/4542, a single computer or private network (LAN) can establish a private connection with another computer or private network over the public network (Internet).

The Netopia 4541/4542 can be used in VPNs either to initiate the connection or to answer it. When used in this way, the routers are said to be *tunnelling* through the public network (Internet). The advantages are that, like your long distance phone call, you don't need a direct line between one computer or LAN and the other, but use the local connections, making it much cheaper; and the information you exchange through your tunnel is private and secure.

Tunneling is a process of creating a private path between a remote user or private network and another private network over some intermediate network, such as the IP-based Internet. A VPN allows remote offices or employees access to your internal business LAN through means of encryption allowing the use of the public Internet to look "virtually" like a private secure network. When two networks communicate with each other through a network based on the Internet Protocol, they are said to be *tunneling* through the IP network.

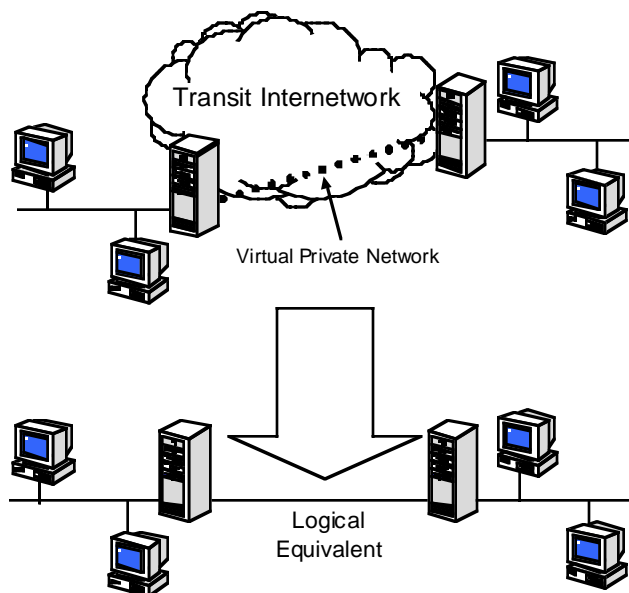

Unlike the phone company, private and public computer networks can use more than one protocol to carry your information over the wires. Three such protocols are in common use for tunnelling, Point-to-Point Tunneling Protocol (PPTP), Ascend Tunnel Management Protocol (ATMP), and IP Security (IPsec). The Netopia Router can use any one.

- Point-to-Point Tunneling Protocol (PPTP) is an extension of Point-to-Point Protocol (PPP) and uses a client and server model. Netopia's PPTP implementation is compatible with Microsoft's and can function as either the client (PAC) or the server (PNS). As a client, a Netopia R-series router can provide all users on a LAN with secure access over the Internet to the resources of another LAN by setting up a tunnel with a Windows NT server running Remote Access Services (RAS) or with another Netopia Router. As a server, a Netopia R-series router can provide remote users a secure connection to the resources of the LAN over a dial-up, cable, DSL, or any other type of Internet access. Because PPTP can create a VPN tunnel using the Dial-Up Networking (DUN) (see "[Dial-Up Networking for VPN](#)" on page 10-18) utility built into Windows 95, 98, or NT, no additional client software is required.
- Ascend Tunnel Management Protocol (ATMP) is the protocol that is implemented in many Ascend routers. ATMP is a simple protocol for connecting nodes and/or networks together over the Internet via a tunnel. ATMP encapsulates IP or other user data without PPP headers within General Routing Encapsulation (GRE) protocol over IP. ATMP is more efficient than PPTP for network-to-network tunnels.
- IPsec stands for IP Security, a set of protocols that supports secure exchange of IP packets at the IP layer. IPsec is deployed widely to implement Virtual Private Networks (VPNs). IPsec supports two encryption modes: Transport and Tunnel. Transport mode encrypts only the data portion (payload) of each packet, but leaves the header untouched. The more secure Tunnel mode encrypts both the header and the payload. On

the receiving side, an IPsec-compliant device decrypts each packet. The Netopia 4541/4542 supports the more secure Tunnel mode.

*DES* stands for Data Encryption Standard, a popular symmetric-key encryption method. DES uses a 56-bit key. The Netopia 4541/4542 offers IPsec DES encryption over the VPN tunnel.

When used to initiate the tunnelled connection, the Netopia 4541/4542 is called a *PPTP Access Concentrator* (*PAC*, in PPTP language), or a *foreign agent* (in ATMP language). When used to answer the tunnelled connection, the Netopia Router is called a *PPTP Network Server* (*PNS*, in PPTP language) or a *home agent* (in ATMP language).

In either case, the Netopia Router wraps, or encapsulates, information that one end of the tunnel exchanges with the other, in a wrapper called General Routing Encapsulation (GRE), at one end of the tunnel, and unwraps, or decapsulates, it at the other end.

Configuring the Netopia Router for use with the different protocols is done through the console-based menu screens. Each type is described in its own section:

- ["About PPTP Tunnels" on page 10-3](#)
- ["About IPsec Tunnels" on page 10-7](#)
- ["About ATMP Tunnels" on page 10-12](#)

Your configuration depends on which protocol you (and the router at the other end of your tunnel) will use, and whether or not you will be using the VPN client software in a standalone remote connection.

---

**Note:** You must choose which protocol you will be using, since you cannot both export PPTP and use ATMP, or vice versa, at the same time.

---

Having both an ATMP tunnel and a PPTP export is not possible because functions require GRE and the router's PPTP export/server does not distinguish the GRE packets it forwards. Since it processes all of them, ATMP tunneling is impaired. For example, you cannot run an ATMP tunnel between two routers and also have PPTP exported on one side.

## Summary

A Virtual Private Network (VPN) connects the components of one network over another network. VPNs accomplish this by allowing you to *tunnel* through the Internet or another public network in a manner that provides the same security and features formerly available only in private networks.

VPNs allow networks to communicate across an IP network. Your local networks (connected to the Netopia Router) can exchange data with remote networks that are also connected to a VPN-capable router.

This feature provides individuals at home, on the road, or in branch offices with a cost-effective and secure way to access resources on remote LANs connected to the Internet with Netopia Routers. The feature is built around three key technologies: PPTP, IPsec, and ATMP.

---

## About PPTP Tunnels

To set up a PPTP tunnel, you create a Connection Profile including the IP address and other relevant information for the remote PPTP partner. You use the same procedure to initiate a PPTP tunnel that terminates at a remote PPTP server or to terminate a tunnel initiated by a remote PPTP client.

## PPTP configuration

To set up the router as a PPTP Network Server (PNS) capable of answering PPTP tunnel requests you must also configure the VPN Default Answer Profile. See ["ATMP/PPTP Default Profile"](#) on page 10-16 for more information.

PPTP is a Datalink Encapsulation option in Connection Profiles. It is not an option in device or link configuration screens, as PPTP is not a native encapsulation. Consequently, the Easy Setup Profile does not offer PPTP datalink encapsulation. See the *User's Reference Guide* for information on creating Connection Profiles.

Channel 4 (and higher) events, such as connections and disconnections, reported in the WAN Event Histories are VPN tunnel events.

To define a PPTP tunnel, navigate to the Add Connection Profile menu from the Main Menu.

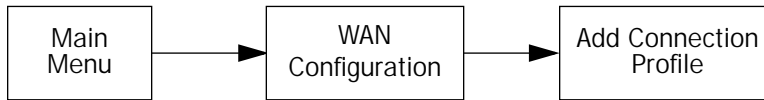

Add Connection Profile

Profile Name:	Profile 1
Profile Enabled:	+-----+
Data Link Encapsulation...	+-----+ PPP Frame Relay RFC1483 ATMP PPTP IPsec +-----+
IP Profile Parameters...	
COMMIT	CANCEL

When you define a Connection Profile as using PPTP by selecting PPTP as the datalink encapsulation method, and then select **Data Link Options**, the PPTP Tunnel Options screen appears.

PPTP Tunnel Options	
PPTP Partner IP Address:	173.167.8.134
Tunnel Via Gateway:	0.0.0.0
Authentication...	CHAP
Data Compression...	None
Send Host name:	tony
Send Password:	*****
Receive Host name:	kimba
Receive Password:	*****
Initiate Connections:	Yes
On Demand:	Yes
Optional Windows NT Domain Name:	
Idle Timeout (seconds):	300

- Enter the **PPTP Partner IP Address**. This specifies the address of the other end of the tunnel.  
If you do not specify the PPTP Partner IP Address the gateway cannot initiate tunnels, i.e., act as a PPTP Access Concentrator (PAC) for this profile. It can only accept tunnel requests as a PPTP Network Server (PNS).
- If you specify the PPTP Partner IP Address, and the address is in the same subnet as the Remote IP Address you specified in the IP Profile Parameters, the **Tunnel Via Gateway** option becomes visible. You can enter the address by which the gateway partner is reached.  
If you do not specify the PPTP Partner IP Address, the router will use the default gateway to reach the partner and the **Tunnel Via Gateway** field is hidden. If the partner should be reached via an alternate port (i.e. the LAN instead of the WAN), the **Tunnel Via Gateway** field allows this path to be resolved.
- From the pop-up menu select an **Authentication** protocol for the PPP connection. Options are PAP, CHAP, or MS-CHAP. The default is PAP. The authentication protocol must be the same on both ends of the tunnel.
- You can specify a **Data Compression** algorithm, either None or Standard LZS, for the PPTP connection.  
**Note:** When the Authentication protocol is MS-CHAP, compression is set to None, and the **Data Compression** option is hidden.
- When the authentication protocol is MS-CHAP, you can specify a **Data Encryption** algorithm for the PPTP connection. Available options are MPPE and None (the default). For other authentication protocols, this option is hidden. When MPPE is negotiated, the WAN Event History reports that it is negotiated as a CCP (compression) type. This is because the MPPE protocol uses a compression engine, even though it is not itself a compression protocol.

---

**Note:** The Netopia 4541/4542 supports 128-bit ("strong") encryption. Unlike MS-CHAP version 1, which supports one-way authentication, MS-CHAP version 2 supports mutual authentication between connected routers and is incompatible with MS-CHAP version 1 (MS-CHAP-V1). When you choose MS-CHAP as the authentication method for the PPTP tunnel, the Netopia router will start negotiating MS-CHAP-V2. If the router you are connecting to does not support MS-CHAP-V2, it will fall back to MS-CHAP-V1, or, if the router you are connecting to does not support MPPE at all, the PPP session will be dropped.

---

- You can specify a **Send Host Name** which is used with Send Secret for authenticating with a remote PNS when the profile is used for initiating a tunnel connection.
- You must specify a **Send Password** (the CHAP and MS-CHAP term for password), used for authenticating the tunnel when initiating a tunnel connection.
- You can specify a **Receive Host Name** which is used with the Receive Secret for authenticating a remote PPTP client.
- You must specify a **Receive Password**, used for authenticating the remote PPTP client.
- You can specify that this router will **Initiate Connections** (acting as a PAC) or only answer them (acting as a PNS).
- Tunnels are normally initiated **On Demand**; however, you can disable this feature. When disabled, the tunnel must be manually established or may be scheduled using the scheduled connections feature. See "[Scheduled connections](#)" on page 7-8.
- Some networks that use Microsoft Windows NT PPTP Network Servers require additional authentication information, called *Windows NT Domain Name*, when answering PPTP tunnel connection requests. Not all Windows NT installations require this information, since not all such installations use this authentication feature. The Windows NT Domain Name is not the same as the Internet domain name, but is the name of a group of servers that share common security policy and user account databases. Your PPTP tunnel partner's administrator will supply this Windows NT Domain Name if it is required. If you configure your Netopia 4541/4542 to initiate PPTP tunnel connections by toggling **Initiate Connections** to **Yes**, the **Optional Windows NT Domain Name** field appears. Enter the domain name your network administrator has supplied.
- You can specify the **Idle Timeout**, an inactivity timer, whose expiration will terminate the tunnel. A value of zero disables the timer. Because tunnels are subject to abrupt termination when the underlying datalink is torn down, use of the Idle Timeout is strongly encouraged.
- Return to the Connection Profile screen by pressing Escape.
- Select **IP Profile Parameters** and press Return.



The IP Profile Parameters screen appears.

IP Profile Parameters

Address Translation Enabled:	Yes
NAT Map List...	Easy-PAT
NAT Server List...	Easy-Servers
Local WAN IP Address:	0.0.0.0
Remote IP Address:	173.167.8.10
Remote IP Mask:	255.255.0.0
Filter Set...	
Remove Filter Set	
RIP Profile Options...	

- Enter the **Remote IP Address** and **Remote IP Mask** for the host to which you want to tunnel.

---

## About IPsec Tunnels

*IPsec* stands for IP Security, a set of protocols that supports secure exchange of IP packets at the IP layer. IPsec is deployed widely to implement Virtual Private Networks (VPNs). See ["Overview" on page 10-1](#) for more information.

IPsec supports two encryption modes: Transport and Tunnel. Transport mode encrypts only the data portion (payload) of each packet, but leaves the header untouched. The more secure Tunnel mode encrypts both the header and the payload. On the receiving side, an IPsec-compliant device decrypts each packet. Netopia Routers support the more secure Tunnel mode.

*DES* stands for Data Encryption Standard, a popular symmetric-key encryption method. DES uses a 56-bit key. The Netopia 4541/4542 offers IPsec DES encryption over the VPN tunnel.

## Configuration

IPsec tunnels are defined in the same manner as PPTP tunnels. You configure the Connection Profile as follows. From the Main Menu navigate to WAN Configuration and then Add Connection Profile.

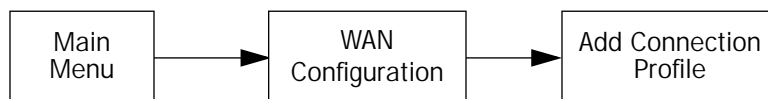

The Add Connection Profile screen appears.

Add Connection Profile

Profile Name:	Profile 1
Profile Enabled:	+-----+
Data Link Encapsulation...	+-----+
Data Link Options...	PPP Frame Relay RFC1483 ATMP PPTP IPsec
IP Profile Parameters...	+-----+
<div style="display: flex; justify-content: space-around; width: 100%;"> <span>COMMIT</span> <span>CANCEL</span> </div>	

- From the **Data Link Encapsulation** pop-up menu select **IPsec**.
- Then select **Data Link Options**. The IPsec Encryption & Authentication Options screen appears.

IPsec Encryption & Authentication Options

Encryption Transform...	+-----+
Encryption Key:	DES NULL
Authentication Type...	ESP
Authentication Transform...	HMAC-MD5-96
Authentication Key:	
<div style="display: flex; justify-content: space-around; width: 100%;"> <span>COMMIT</span> <span>CANCEL</span> </div>	

- You must specify an **Encryption Transform**. The choices are **DES** or **NULL**. The default is **DES**.

IPsec Encryption & Authentication Options

Encryption Transform...	DES
Encryption Key:	
Authentication Type...	ESP
Authentication Transform...	HMAC-MD5-96
Authentication Key:	

COMMIT
CANCEL

Enter a key of 16 Hex digits, e.g. '1234567890ABCDEF'

- You must enter an **Encryption Key** if the Encryption Transform is DES. The key for DES must be a hexadecimal string of 16 characters, using Hex characters only: '0'-'9', 'A'-'F' and 'a' - 'f'. No key entry appears if the encryption transform is NULL.
  - You must specify an **Authentication Type**. The default is **ESP**, and the choices are **ESP**, **None**, or **AH**. **ESP** provides confidentiality over the IP payload and optional authentication of the IP payload and ESP header. **AH** (Authentication Header) provides authentication over the immutable parts of the IP header, AH header and the IP payload. ESP is preferred.
  - You must specify an **Authentication Transform** if the Authentication Type is anything other than None. The default is **HMAC-MD5-96**, and the choices are **HMAC-MD5-96** or **HMAC-SHA1-96** for both AH and ESP.
  - You must specify an **Authentication Key** if the Authentication Type is anything other than None. The key must be an ASCII string of up to 48 characters for both HMAC-MD5-96 and HMAC-SHA1-96.
- Key:** The key is a hexadecimal entry of 16 bytes (32 characters of input) for MD5 and 20 bytes (40 characters of input) for SHA1. It is not possible to view the Encryption Keys or Authentication Key once they have been set.
- Press **COMMIT** to return to the Add Connection Profile screen.
  - Select **IP Profile Parameters**.

## IP Profile Parameters

The following IP Profile Options screen is displayed for an IPsec Connection Profile.

IP Profile Options	
SPI (Security Parameters Index):	123456789
Remote Tunnel Endpoint Address:	0.0.0.0
Idle Timeout (seconds):	300
Remote Members Network:	0.0.0.0
Remote Members Mask:	0.0.0.0
Address Translation Enabled:	Yes
NAT Map List...	Easy-PAT List
NAT Server List...	Easy-Servers
PAT IP Address:	1.1.1.1
Filter Set...	<<None>>
Remove Filter Set	
Advanced IP Profile Options...	
COMMIT	CANCEL

- You must specify an **SPI (Security Parameters Index)**, which is the ESP receive side SPI and the default SPI for ESP transmit, AH receive, and AH transmit. It must be unique relative to any other configuration profile "ESP Receive SPIs." (See ["Advanced IP Profile Options"](#) on page 10-11.)
- You must specify a **Remote Tunnel Endpoint Address**. Specify the IP address of your tunnel partner, the endpoint of the tunnel. The Remote Tunnel Endpoint Address may be 0.0.0.0, which implies that the IPsec tunnel will not be established until packets are received on the SPI specified. At that time the tunnel will be bound to the Remote Tunnel Endpoint until traffic from the remote gateway ceases for a timeout period.
- You can specify the **Idle Timeout**, an inactivity timer, whose expiration will terminate the tunnel. A value of zero disables the timer. Because tunnels are subject to abrupt termination when the underlying datalink is torn down, use of the Idle Timeout is strongly encouraged.
- You must specify a **Remote Members Network** address. This specifies the subnet of the remote IPsec tunnel and will be used with the Remote Members Mask to determine and set the route.
- You must specify a **Remote Members Mask**. This is the subnet mask of the remote subnet to which the IPsec tunnel will route.
- You can specify **Address Translation Enabled**. For more information see [Chapter 9, "Multiple Network Address Translation."](#) If Address Translation Enabled is set to **Yes**, you can specify the following three fields:
  - **NAT Map List**
  - **NAT Server List**
  - **PAT IP Address**  
(**Note:** Since there is no protocol to derive this address, 0.0.0.0 is not permitted.)

Map Lists, Server Lists, and PAT addresses are described in detail in [Chapter 9, "Multiple Network Address Translation."](#)

- You can specify a **Filter Set**. See ["About filters and filter sets"](#) on page 11-4.
- You can remove a **Filter Set**.
- You can choose to configure **Advanced IP Profile Options** (see ["Advanced IP Profile Options,"](#) in the following section).

---

**Note:** The SPI title field above changes to **SPI (Security Parameters Index) -- Use Advanced IP Profile Options** if any of the SPI values differ from each other.

---

## Advanced IP Profile Options

```

                                Advanced IP Profile Options

ESP Receive SPI:                123456789
ESP Transmit SPI:              123456789
AH Receive SPI:                123456789
AH Transmit SPI:               123456789

Local Tunnel Endpoint Address:  0.0.0.0
Next Hop Gateway:              0.0.0.0

SPI = Security Parameters Index, valid range is 1 - 4294967295.
```

- You can specify an **ESP Receive SPI**. The value must be unique over the set of all ESP SPIs specified for the remote tunnel endpoint.
- You can specify an **ESP Transmit SPI**. The value must be unique over the set of all ESP SPIs specified for the remote tunnel endpoint.
- You can specify an **AH Receive SPI** if AH authentication has been requested. The value must be unique over the set of all AH SPIs specified for the router.
- You can specify an **AH Transmit SPI** if AH authentication has been requested. The value must be unique over the set of all AH SPIs specified for the remote tunnel endpoint.
- You can specify a **Local Tunnel Endpoint Address**. If not 0.0.0.0, this value must be one of the assigned interface addresses, either WAN or LAN. This is used as the source address of all IPsec traffic.
- You can specify a **Next Hop Gateway**. If you specify the Remote Tunnel Endpoint Address, and the address is in the same subnet as the Remote Members Network you specified in the IP Profile Parameters, the **Next Hop Gateway** option allows you to enter the address by which the gateway partner is reached.

If you do not specify the Remote Tunnel Endpoint Address, the router will use the default gateway to reach the partner. If the partner should be reached via an alternate port (for example, the LAN instead of the WAN), the **Next Hop Gateway** field allows this path to be resolved.

### Interoperation with other features

- Address serving is not supported through IPsec Tunnels.
- AH is not supported through an interface that has NAT applied to it. NAT may be applied to the inner payload.
- AH is not supported through an interface which is either Unnumbered or Numbered with a dynamically assigned address unless the Local Tunnel Endpoint address is specified in the Advanced IP Profile Options screen.

---

### About ATMP Tunnels

To set up an ATMP tunnel, you create a Connection Profile including the IP address and other relevant information for the remote ATMP partner. ATMP uses the terminology of a *foreign agent* that initiates tunnels and a *home agent* that terminates them. You use the same procedure to initiate or terminate an ATMP tunnel. Used in this way, the terms *initiate* and *terminate* mean the beginning and end of the tunnel; they do not mean *activate* and *deactivate*.

ATMP is a tunneling protocol, with two basic aspects. Tunnels are created and torn down using a session protocol that is UDP-based. User (or client) data is transferred across the tunnel by encapsulating the client data within Generic Routing Encapsulation (GRE). The GRE data is then routed using standard methods.

### ATMP configuration

ATMP is a Datalink Encapsulation option in Connection Profiles. It is not an option in device or link configuration screens, since ATMP is not a native encapsulation. The Easy Setup Profile does not offer ATMP datalink encapsulation. See the *User's Reference Guide* for information on creating Connection Profiles.

The WAN Event History screens will report VPN tunnel events, such as connections and disconnections, as Channel 4 (and higher) events.

To define an ATMP tunnel, navigate to the **Add Connection Profile** menu from the Main Menu.

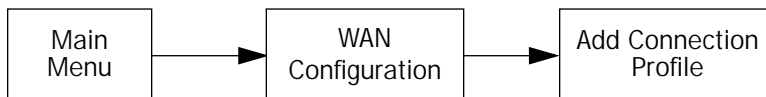

Add Connection Profile	
Profile Name:	Profile 2
Profile Enabled:	+-----+
Data Link Encapsulation...	PPP
Data Link Options...	Frame Relay
	RFC1483
	ATMP
	PPTP
	IPsec
	+-----+
IP Profile Parameters...	
COMMIT	CANCEL

When you define a Connection Profile as using ATMP by selecting ATMP as the datalink encapsulation method, and then select **Data Link Options**, the ATMP Tunnel Options screen appears.

ATMP Tunnel Options	
ATMP Partner IP Address:	173.167.8.134
Tunnel Via Gateway:	0.0.0.0
Network Name:	sam.net
Password:	****
Data Encryption...	DES
Key String:	
Initiate Connections:	Yes
On Demand:	Yes
Idle Timeout (seconds):	300

**Note:** An ATMP tunnel cannot be assigned a dynamic IP address by the remote server, as in a PPP connection. When you define an ATMP tunnel profile, the Local WAN IP Address, assigned in the IP Profile Parameters screen, must be the true IP address, not 0.0.0.0, if NAT is enabled.

- **ATMP Partner IP Address** specifies the address of the other end of the tunnel. When unspecified, the gateway can not initiate tunnels (i.e., act as a foreign agent) for this profile; it can only accept tunnel requests as a home agent.
- When you specify the ATMP Partner IP Address, and the address is in the same subnet as the Remote IP Address you specified in the IP Profile Parameters, you can specify the route (**Tunnel Via Gateway**) by which

the gateway partner is reached. If you do not specify the ATMP Partner IP Address, the router will use the default gateway to reach the partner and the **Tunnel Via Gateway** field is hidden. If the partner should be reached via an alternate port (i.e., the LAN instead of the WAN), the **Tunnel Via Gateway** field allows this path to be resolved.

- You can specify a **Network Name**. When the tunnel partner is another Netopia router, this name may be used to match against a Connection Profile. When the partner is an Ascend router in Gateway mode, then **Network Name** is used by the Ascend router to match a gateway profile. When the partner is an Ascend router in Router mode, leave this field blank.

- You must specify a **Password**, used for authenticating the tunnel.

**Note:** The Password entry will be the same for both ends of the tunnel.

- For Netopia-to-Netopia connections only, you can specify a **Data Encryption** algorithm for the ATMP connection from the pop-up menu, either DES or None. None is the default.

**Note:** Ascend does not support DES encryption for ATMP tunnels.

- You must specify a **Key String** of up to (and including) 20 characters when DES is selected. When encryption is None, this field is invisible.
- You can specify that this router will **Initiate Connections**, acting as a foreign agent (**Yes**), or only answer them, acting as a home agent (**No**).
- Tunnels are normally initiated **On Demand**; however, you can disable this feature. When disabled, the tunnel must be manually established through the call management screens.
- You can specify the **Idle Timeout**, an inactivity timer, whose expiration will terminate the tunnel. A value of zero disables the timer. Because tunnels are subject to abrupt termination when the underlying datalink is torn down, use of the Idle Timeout is strongly encouraged.
- Return to the Connection Profile screen by pressing Escape.
- Select **IP Profile Parameters** and press Return. The IP Profile Parameters screen appears.



IP Profile Parameters	
Address Translation Enabled:	Yes
NAT Map List...	Easy-PAT
NAT Server List...	Easy-Servers
Local WAN IP Address:	0.0.0.0
Remote IP Address:	173.167.8.10
Remote IP Mask:	255.255.0.0
Filter Set...	
Remove Filter Set	
RIP Profile Options...	

- Enter the **Remote IP Address** and **Remote IP Mask** for the host to which you want to tunnel.

---

## Encryption Support

Encryption is a method for altering user data into a form that is unusable by anyone other than the intended recipient. The recipient must have the means to decrypt the data to render it usable to them. The encryption process protects the data by making it difficult for any third party to get at the original data.

Netopia PPTP is fully compatible with Microsoft Point-to-Point Encryption (MPPE) data encryption for user data transfer over the PPTP tunnel. Microsoft Windows NT Server provides MPPE encryption capability only when Microsoft Challenge Handshake Authentication Protocol (MS-CHAP) is enabled. Netopia complies with this feature to allow MPPE only when MS-CHAP is negotiated. MS-CHAP and MPPE are user-selectable options in the PPTP Tunnel Options screen. If either the client or the server side specifies encryption, then encryption becomes mandatory for both.

Netopia's ATMP implementation supports Data Encryption Standard (DES) data encryption for user data transfer over the ATMP tunnel between two Netopia routers. The encryption option, none or DES, is a selectable option in the ATMP Tunnel Options screen.

## MS-CHAP V2 and 128-bit strong encryption

### Notes:

- The Netopia 4541/4542 supports 128-bit ("strong") encryption when using PPTP tunnels.  
ATMP does not have an option of using 128-bit MPPE. If you are using ATMP between two Netopia routers you can optionally set 56-bit DES encryption.
- When you choose MS-CHAP as the authentication method for a PPTP tunnel, the Netopia router will start negotiating MS-CHAPv2. If the router or VPN adapter client you are connecting to does not support MS-CHAPv2, the Netopia router will fall back to MS-CHAPv1, or, if the router or VPN adapter client you are connecting to does not support MPPE at all, the PPP session will be dropped. This is done automatically

and transparently.

---

## ATMP/PPTP Default Profile

The WAN Configuration menu offers a ATMP/PPTP Default Profile option. Use this selection when your router is acting as the server for VPN connections, that is, when you are on the answering end of the tunnel establishment. The ATMP/PPTP Default Profile determines the way the attempted tunnel connection is answered.

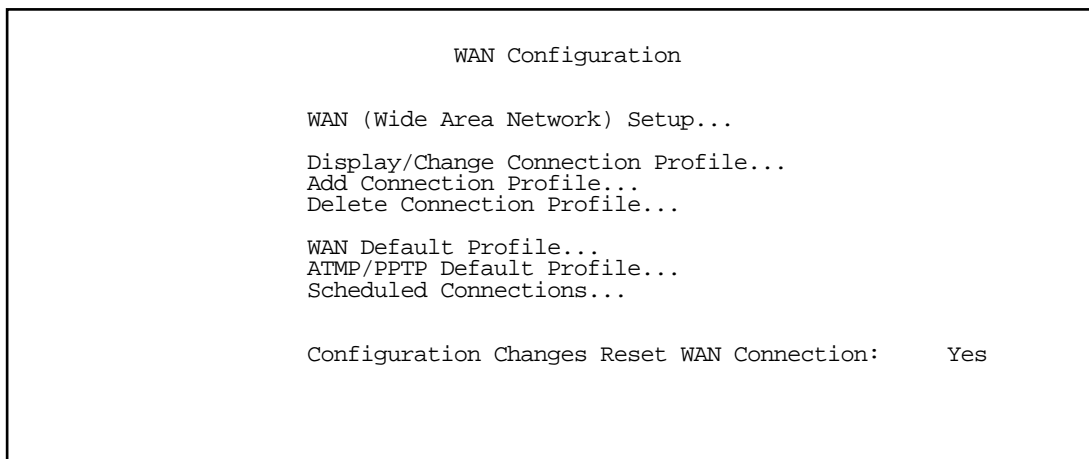

To set the parameters under which the router will answer attempted VPN connections, select **ATMP/PPTP Default Profile** and press Return. The ATMP/PPTP Default Profile screen appears.

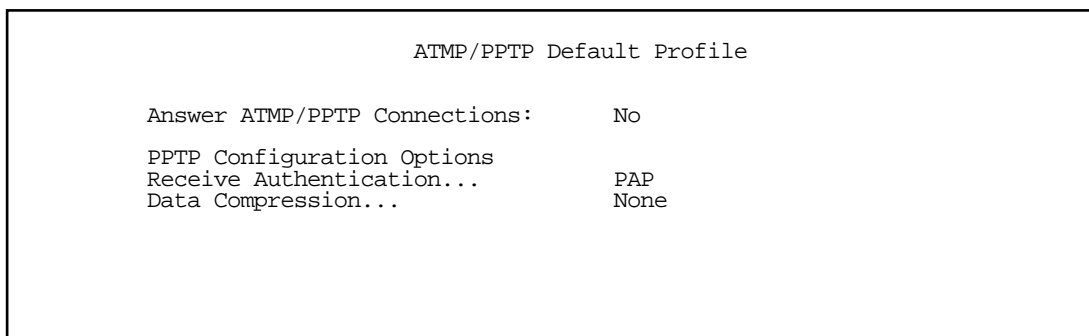

- Toggle **Answer ATMP/PPTP Connections** to **Yes** if you want the router to accept VPN connections or **No** (the default) if you do not.
- For PPTP tunnel connections only, you must define what type of authentication these connections will use. Select **Receive Authentication** and press Return. A pop-up menu offers the following options: PAP (the default), CHAP, or MS-CHAP.
- If you chose PAP or CHAP authentication, from the **Data Compression** pop-up menu select either None (the default) or Standard LZS.

If you chose MS-CHAP authentication, the **Data Compression** option is not required, and this menu item becomes hidden.

---

## VPN QuickView

You can view the status of your VPN connections in the VPN QuickView screen.

From the Main Menu select QuickView and then VPN QuickView.

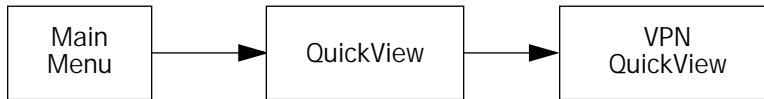

The VPN QuickView screen appears.

VPN Quick View						
Profile Name-----	Type-----	Rx Pckts---	Tx Pckts--	RxDiscard--	Remote Address--	
HA <-> FA1 (Jony Fon	ATMP	99	99	0	173.166.82.8	
HA <-> FA3 (Sleve M.	ATMP	13	14	0	173.166.117.91	

**Profile Name:** Lists the name of the Connection Profile being used, if any.

**Type:** Shows the data link encapsulation method (PPTP or ATMP).

**Rx Pckts:** Shows the number of packets received via the VPN tunnel.

**Tx Pckts:** Shows the number of packets transmitted via the VPN tunnel.

**Rx Discard:** Shows the number of packets discarded.

**Remote Address:** Shows the tunnel partner's IP address.

## *Dial-Up Networking for VPN*

Microsoft Windows Dial-Up Networking software permits a remote standalone workstation to establish a VPN tunnel to a PPTP server such as a Netopia Router located at a central site. Dial-Up Networking also allows a mobile user who may not be connected to a PAC to dial into an intermediate ISP and establish a VPN tunnel to, for example, a corporate headquarters, remotely. Netopia Routers also can serve as a PAC at the workstation's site, making it unnecessary for the standalone workstation to initiate the tunnel. In such a case, the Dial-Up Networking software is not required, since the Netopia Router initiates the tunnel.

This section is provided for users who may require the VPN client software for Dial-Up Networking in order to connect to an ISP who provides a PPTP account.

Microsoft Windows Dial-Up Networking (DUN) is the means by which you can initiate a VPN tunnel between your individual remote client workstation and a private network such as your corporate LAN via the Internet. DUN is a software adapter that allows you to establish a tunnel.

DUN is a free add-on available for Windows 95, and comes standard with Windows 98 and Windows NT. The VPN tunnel behaves as a private network connection, unrelated to other traffic on the network. Once you have installed Dial-Up Networking, you will be able to connect to your remote site as if you had a direct private connection, regardless of the intervening network(s) through which your data passes. You may need to install the Dial-Up Networking feature of Windows 95, 98, or 2000 to take advantage of the virtual private networking feature of your Netopia router.

**Note:** For the latest information and tech notes on Dial-Up Networking and VPNs be sure to visit the Netopia website at <http://www.netopia.com> and, for the latest software and release notes, the Microsoft website at <http://www.microsoft.com>.

## *Installing Dial-Up Networking*

Check to see if Dial-Up Networking is already installed on your PC. Open your My Computer (or whatever you have named it) icon on your desktop. If there is a folder named Dial-Up Networking, you don't have to install it. If there is no such folder, you must install it from your system disks or CDROM. Do the following:

1. From the **Start** menu, select **Settings** and then **Control Panel**.
2. In the Control Panel window, double-click the **Add/Remove Programs** icon.  
The Add/Remove Programs Properties window appears.
3. Click the **Windows Setup** tab.
4. Double-click **Communications**.

The Communications window appears.



5. In the Communications window, select **Dial-Up Networking** and click the **OK** button.  
This returns you to the Windows Setup screen. Click the **OK** button.
6. Respond to the prompts to install Dial-Up Networking from the system disks or CDROM.
7. When prompted, reboot your PC.

## *Creating a new Dial-Up Networking profile*

A Dial-Up Networking profile is like an address book entry that contains the information and parameters you need for a secure private connection. You can create this profile by using either the Internet Connection Wizard or the Make New Connection feature of Dial-Up Networking. The following instructions tell you how to create the profile with the Make New Connection feature. Do the following:

1. Double-click the **My Computer** (or whatever you have named it) icon on your desktop.  
Open the Dial-Up Networking folder, and then double-click **Make New Connection**. The Make New Connection wizard window appears.
2. Type a name for this connection (such as the name of your company, or the computer you are dialing into).  
From the pull-down menu, select the device you intend to use for the virtual private network connection. This can be any device you have installed or connected to your PC. Click the **Next** button. A screen appears with fields for you to enter telephone numbers for the computer you want to connect to.
3. Type the directory number or the **Virtual Circuit Identifier** number.  
This number is provided by your ISP or corporate administrator. Depending on the type of device you are using, the number may or may not resemble an ordinary telephone directory number.
4. Click the **Next** button.  
The final window will give you a chance to accept or change the name you have entered for this profile. If you are satisfied with it, click the **Finish** button. Your profile is complete.

## Configuring a Dial-Up Networking profile

Once you have created your Dial-Up Networking profile, you configure it for TCP/IP networking to allow you to connect to the Internet through your Internet connection device. Do the following:

1. Double-click the **My Computer** (or whatever you have named it) icon on your desktop.  
Open the Dial-Up Networking folder. You will see the icon for the profile you created in the previous section.
2. Right-click the icon and from the pop-up menu select **Properties**.
3. In the Properties window click the **Server Type** button.

From the Type of Dial-up Server pull-down menu select the appropriate type of server for your system version:



- Windows 95 users select **PPP: Windows 95, Windows NT 3.5, Internet**
- Windows 98 users select **PPP: Windows 98, Windows NT Server, Internet**

In the Allowed network protocols area check **TCP/IP** and uncheck all of the other checkboxes.

**Note:** Netopia's PPTP implementation does not currently support tunnelling of IPX and NetBEUI protocols.

- Click the **TCP/IP Settings** button.

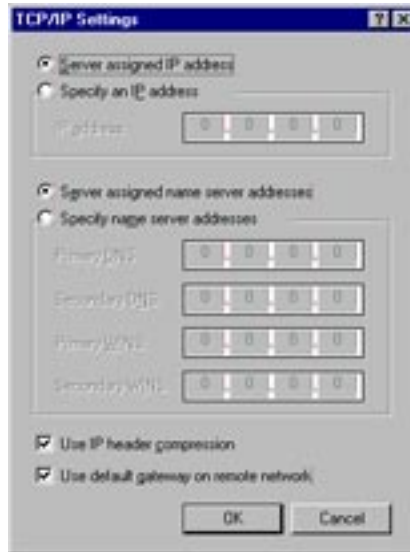

- If your ISP uses dynamic IP addressing (DHCP), select the Server assigned IP address radio button.
  - If your ISP uses static IP addressing, select the Specify an IP address radio button and enter your assigned IP address in the fields provided. Also enter the IP address in the Primary and Secondary DNS fields.
- Click the **OK** button in this window and the next two windows.

---

## Installing the VPN Client

Before Installing the VPN Client you must have TCP/IP installed and have an established Internet connection.

### Windows 95 VPN installation

- From your Internet browser navigate to the following URL:  
<http://www.microsoft.com/NTServer/nts/downloads/recommended/dun13win95/releasenotes.aso>  
 Download the Microsoft Windows 95 VPN patch dun 1.3 to the Windows 95 computer you intend to use as a VPN client with PPTP. Follow the installation instructions.
- From the Windows 95 **Start** menu select **Settings**, then **Control Panel** and click once.  
 The Control Panel screen appears.
- Double-click **Add/Remove Programs**.  
 The Add/Remove Programs screen appears.
- Click the **Windows Setup** tab.  
 The Windows Setup screen will be displayed within the top center box.
- Highlight **Communications** and double-click.

This displays a list of possible selections for the communications option. Active components will have a check in the checkboxes to their left.

6. Check **Dial Up Networking** at the top of the list and **Virtual Private Networking** at the bottom of the list.
7. Click **OK** at the bottom right on each screen until you return to the Control Panel. Close the Control Panel by clicking the upper right corner X.
8. Double-click the **My Computer** icon (normally at the left upper corner of the screen).

This will display the devices within My Computer. Scroll down the list to **Dial-Up Networking** and double-click it.

9. Double click **Make New Connection**.

This displays the Make New Connection installation screen. In this screen you will see a box labelled **Select a device**. From the pull-down menu to the right, select **Microsoft VPN Adapter**.

Click the **Next** button at the bottom of the screen

This displays the **VPN Host** screen. In the box to the top center of the screen enter your VPN server's IP address (for example, 192.168.xxx.xxx. This is not a proper Internet address)

## *Windows 98 VPN installation*

1. From the Windows 98 **Start** menu select **Settings**, then **Control Panel** and click once.

The Control Panel screen appears.

2. Double-click **Add/Remove Programs**.

The Add/Remove Programs screen appears.

3. Click the **Windows Setup** tab.

The Windows Setup screen will be displayed within the top center box.

4. Double-click **Communications**.

This displays a list of possible selections for the communications option. Active components will have a check in the checkboxes to their left.

5. Check **Dial Up Networking** at the top of the list and **Virtual Private Networking** at the bottom of the list.
6. Click **OK** at the bottom right on each screen until you return to the Control Panel. Close the Control Panel by clicking the upper right corner X.
7. Double-click the **My Computer** icon (normally at the left upper corner of the screen).

This will display the devices within My Computer. Scroll down the list to **Dial-Up Networking** and double-click it.

8. Double click **Make New Connection**.

This displays the Make New Connection installation screen. In this screen you will see a box labelled **Select a device**. From the pull-down menu to the right, select **Microsoft VPN Adapter**.

Click the **Next** button at the bottom of the screen

This displays the **VPN Host** screen. In the box to the top center of the screen enter your VPN server's IP address (for example, 192.168.xxx.xxx. This is not a proper Internet address)



## Connecting using Dial-Up Networking

A Dial-Up Networking connection will be automatically launched whenever you run a TCP/IP application, such as a web browser or email client. When you first run the application a Connect To dialog box appears in which you enter your User name and Password. If you check the Save password checkbox, the system will remember your User name and Password, and you won't be prompted for them again.

---

## Allowing VPNs through a Firewall

An administrator interested in securing a network will usually combine the use of VPNs with the use of a firewall or some similar mechanism. This is because a VPN is not a complete security solution, but rather a component of overall security. Using a VPN will add security to transactions carried over a public network, but a VPN alone will not prevent a public network from infiltrating a private network. Therefore, you should combine use of a firewall with VPNs, where the firewall will secure the private network from infiltration from a public network, and the VPN will secure the transactions that must cross the public network.

A strict firewall may not be provisioned to allow VPN traffic to pass back and forth as needed. In order to ensure that a firewall will allow a VPN, certain attributes must be added to the firewall's provisioning. The provisions necessary vary slightly between ATMP and PPTP, but both protocols operate on the same basic premise: there are control and negotiation operations, and there is the tunnelled traffic that carries the payload of data between the VPN endpoints. The difference is that ATMP uses UDP to handle control and negotiation, while PPTP uses TCP. Then both ATMP and PPTP use GRE to carry the payload.

For PPTP negotiation to work, TCP packets inbound and outbound destined for port 1723 must be allowed. Likewise, for ATMP negotiation to work, UDP packets inbound and outbound destined for port 5150 must be allowed. Source ports are dynamic, so, if possible, make this flexible, too. Additionally, PPTP and ATMP both require a firewall to allow GRE bi-directionally.

The following sections illustrate a sample filtering setup to allow either PPTP or ATMP traffic to cross a firewall:

- "PPTP example" on page 10-24
- "ATMP example" on page 10-26

Make your own appropriate substitutions. For more information on filters and firewalls, see [Chapter 11](#), "Security."

## PPTP example

To enable a firewall to allow PPTP traffic, you must provision the firewall to allow inbound and outbound TCP packets specifically destined for port 1723. The source port may be dynamic, so often it is not useful to apply a compare function upon this portion of the control/negotiation packets. You must also set the firewall to allow inbound and outbound GRE packets, enabling transport of the tunnel payload.

From the Main Menu navigate to Display/Change IP Filter Set, and from the pop-up menu select **Basic Firewall**.



Select **Display/Change Input Filter**.

*Display/Change Input Filter screen*

+#	Source IP Addr	Dest IP Addr	Proto	Src.Port	D.Port	On?	Fwd
1	0.0.0.0	0.0.0.0	TCP	NC	=2000	Yes	No
2	0.0.0.0	0.0.0.0	TCP	NC	=6000	Yes	No

Select Input Filter 1 and press Return. In the Change Input Filter 1 screen, set the Destination Port information as shown below.

Change Input Filter 1	
Enabled:	Yes
Forward:	Yes
Source IP Address:	0.0.0.0
Source IP Address Mask:	0.0.0.0
Dest. IP Address:	0.0.0.0
Dest. IP Address Mask:	0.0.0.0
Protocol Type:	TCP
Source Port Compare...	No Compare
Source Port ID:	0
Dest. Port Compare...	Equal
Dest. Port ID:	1723
Established TCP Conns. Only:	No

Select Input Filter 2 and press Return. In the Change Input Filter 2 screen, set the Protocol Type to allow GRE as shown below.

```

Change Input Filter 2

Enabled:                Yes
Forward:                Yes

Source IP Address:     0.0.0.0
Source IP Address Mask: 0.0.0.0

Dest. IP Address:     0.0.0.0
Dest. IP Address Mask: 0.0.0.0

Protocol Type:         GRE

```

In the Display/Change Filter Set screen select **Display/Change Output Filter**.

*Display/Change Output Filter screen*

```

+--#-----Source IP Addr-----Dest IP Addr-----Proto-Src.Port-D.Port--On?-Fwd--+
|-----|-----|-----|-----|-----|-----|-----|-----|-----|-----|
| 1   0.0.0.0   0.0.0.0   TCP   NC   =1723   Yes Yes |
| 2   0.0.0.0   0.0.0.0   GRE   --   --       Yes Yes |
|-----|-----|-----|-----|-----|-----|-----|-----|-----|-----|

```

Select Output Filter 1 and press Return. In the Change Output Filter 1 screen, set the Protocol Type and Destination Port information as shown below.

```

Change Output Filter 1

Enabled:                Yes
Forward:                Yes

Source IP Address:     0.0.0.0
Source IP Address Mask: 0.0.0.0

Dest. IP Address:     0.0.0.0
Dest. IP Address Mask: 0.0.0.0

Protocol Type:         TCP
Source Port Compare... No Compare
Source Port ID:        0
Dest. Port Compare...  Equal
Dest. Port ID:         1723
Established TCP Conns. Only: No

```

Select Output Filter 2 and press Return. In the Change Output Filter 2 screen, set the Protocol Type to allow GRE as shown below.

```

Change Output Filter 2

Enabled:                Yes
Forward:               Yes

Source IP Address:     0.0.0.0
Source IP Address Mask: 0.0.0.0

Dest. IP Address:     0.0.0.0
Dest. IP Address Mask: 0.0.0.0

Protocol Type:        GRE
    
```

### ATMP example

To enable a firewall to allow ATMP traffic, you must provision the firewall to allow inbound and outbound UDP packets specifically destined for port 5150. The source port may be dynamic, so often it is not useful to apply a compare function on this portion of the control/negotiation packets. You must also set the firewall to allow inbound and outbound GRE packets (Protocol 47, Internet Assigned Numbers Document, RFC 1700), enabling transport of the tunnel payload.

From the Main Menu navigate to Display/Change IP Filter Set, and from the pop-up menu select **Basic Firewall**.



Select **Display/Change Input Filter**.

*Display/Change Input Filter screen*

```

+---#----Source IP Addr----Dest IP Addr-----Proto-Src.Port-D.Port--On?-Fwd---+
| 1   0.0.0.0                0.0.0.0                TCP   NC       =2000  Yes No  |
| 2   0.0.0.0                0.0.0.0                TCP   NC       =6000  Yes No  |
+-----+-----+-----+-----+-----+-----+-----+-----+-----+
    
```

Select Input Filter 1 and press Return. In the Change Input Filter 1 screen, set the Destination Port information as shown below.

```
Change Input Filter 1

Enabled:                Yes
Forward:                Yes

Source IP Address:     0.0.0.0
Source IP Address Mask: 0.0.0.0

Dest. IP Address:     0.0.0.0
Dest. IP Address Mask: 0.0.0.0

Protocol Type:         TCP
Source Port Compare... No Compare
Source Port ID:        0
Dest. Port Compare... Equal
Dest. Port ID:         1723
Established TCP Conns. Only: No
```

Select Input Filter 2 and press Return. In the Change Input Filter 2 screen, set the Protocol Type to allow GRE as shown below.

```
Change Input Filter 2

Enabled:                Yes
Forward:                Yes

Source IP Address:     0.0.0.0
Source IP Address Mask: 0.0.0.0

Dest. IP Address:     0.0.0.0
Dest. IP Address Mask: 0.0.0.0

Protocol Type:         GRE
```

In the Display/Change Filter Set screen select **Display/Change Output Filter**.

*Display/Change Output Filter screen*

+--#-----	Source IP Addr-----	Dest IP Addr-----	Proto	Src.Port	D.Port	--On?	Fwd--+
1	0.0.0.0	0.0.0.0	TCP	NC	=1723	Yes	Yes
2	0.0.0.0	0.0.0.0	GRE	--	--	Yes	Yes

Select Output Filter 1 and press Return. In the Change Output Filter 1 screen, set the Protocol Type and Destination Port information as shown below.

```

Change Output Filter 1

Enabled:                               Yes
Forward:                               Yes

Source IP Address:                     0.0.0.0
Source IP Address Mask:                 0.0.0.0

Dest. IP Address:                       0.0.0.0
Dest. IP Address Mask:                   0.0.0.0

Protocol Type:                          UDP
Source Port Compare...                   No Compare
Source Port ID:                          0
Dest. Port Compare...                     No Compare
Dest. Port ID:                            5150
    
```

Select Output Filter 2 and press Return. In the Change Output Filter 2 screen, set the Protocol Type to allow GRE as shown below.

## Change Output Filter 2

Enabled:	Yes
Forward:	Yes
Source IP Address:	0.0.0.0
Source IP Address Mask:	0.0.0.0
Dest. IP Address:	0.0.0.0
Dest. IP Address Mask:	0.0.0.0
Protocol Type:	GRE





# Chapter 11

## Security

The Netopia 4541/4542 provides a number of security features to help protect its configuration screens and your local network from unauthorized access. Although these features are optional, it is strongly recommended that you use them.

This section covers the following topics:

- “Suggested security measures” on page 11-1
- “User accounts” on page 11-1
- “Telnet access” on page 11-3
- “About filters and filter sets” on page 11-4
- “Working with IP filters and filter sets” on page 11-12
- “Firewall tutorial” on page 11-20

---

### *Suggested security measures*

In addition to setting up user accounts, Telnet access, and filters (all of which are covered later in this chapter), there are other actions you can take to make the Netopia 4541/4542 and your network more secure:

- Change the SNMP community strings (or passwords). The default community strings are universal and could easily be known to a potential intruder.
- Set the answer profile so it must match incoming calls to a connection profile.
- Leave the Enable Dial-in Console Access option set to No.
- When using AURP, accept connections only from configured partners.
- Configure the Netopia 4541/4542 through the serial console port to ensure that your communications cannot be intercepted.

---

### *User accounts*

When you first set up and configure the Netopia 4541/4542, no passwords are required to access the configuration screens. Anyone could tamper with the router’s configuration by simply connecting it to a console.

However, by adding user accounts, you can protect the most sensitive screens from unauthorized access. User accounts are composed of name/password combinations that can be given to authorized users.

#### **Caution!**

You are strongly encouraged to add protection to the configuration screens. Unprotected screens could allow an unauthorized user to compromise the operation of your entire network.

## 11-2 User's Reference Guide

Once user accounts are created, users who attempt to access protected screens will be challenged. Users who enter an incorrect name or password are returned to a screen requesting a name/password combination to access the Main Menu.

To set up user accounts, in the System Configuration screen select **Security** and press Return. The Security Options screen appears.

```
Security Options

Enable Telnet Console Access:           Yes
Enable Telnet Access to SNMP Screens:   Yes
Console Access timeout (seconds):       600

Show Users...
Add User...
Delete User...

Advanced Security Options...

Password for This Screen (11 chars max):

Return/Enter accepts * Tab toggles * ESC cancels.
Set up configuration access options here.
```

### *Protecting the Security Options screen*

The first screen you should protect is the Security Options screen, because it controls access to the configuration screens. Access to the Security Options screen can be protected with a password.

Select **Password for This Screen** in the Security Options screen and enter a password. Make sure this password is secure and is different from any of the user account passwords.

### *Protecting the configuration screens*

You can protect the configuration screens with user accounts. You can administer the accounts from the Security Options screen. You can create up to four accounts.

To display a view-only list of user accounts, select **Show Users** in the Security Options screen.

To add a new user account, select **Add User** in the Security Options screen and press Return. The Add Name With Write Access screen appears.

Add Name With Write Access

Enter Name:

Enter Password (11 characters max):

ADD NAME/PASSWORD NOW                      CANCEL

Follow these steps to configure the new account:

1. Select **Enter Name** and enter a descriptive name (for example, the user's first name).
2. Select **Enter Password** and enter a password.
3. To accept the new name/password combination, select **ADD NAME/PASSWORD NOW** and press Return. To exit the Add Name With Write Access screen without saving the new account, select **CANCEL**. You are returned to the Security Options screen.

To delete a user account, select **Delete User** to display a list of accounts. Select an account from the list and press Return to delete it. To exit the list without deleting the selected account, press Escape.

---

## *Telnet access*

Telnet is a TCP/IP service that allows remote terminals to access hosts on an IP network. The Netopia 4541/4542 supports Telnet access to its configuration screens.

### **Caution!**

You should consider password-protecting or restricting Telnet access to the Netopia 4541/4542 if you suspect there is a chance of tampering.

To password-protect the configuration screens, select Easy Setup from the Main Menu, and go to the Easy Setup Security Configuration screen. By entering a name and password pair in this screen, all access via serial, Telnet, SNMP, and Web server will be password-protected.

To restrict Telnet access, select **Security** in the Advanced Configuration menu. The Security Options screen will appear. There are two levels of Telnet restriction available:

- To restrict Telnet access to the SNMP screens, select **Enable Telnet Access to SNMP Screens** and toggle it to **No**. (See "SNMP traps" on page 12-11.)
- To restrict Telnet access to all of the configuration screens, select **Enable Telnet Console Access** and toggle it to **No**.

---

### *About filters and filter sets*

Security should be a high priority for anyone administering a network connected to the Internet. Using packet filters to control network communications can greatly improve your network's security.

The Netopia 4541/4542's packet filters are designed to provide security for the Internet connections made to and from your network. You can customize the router's filter sets for a variety of packet filtering applications. Typically, you use filters to selectively admit or refuse TCP/IP connections from certain remote networks and specific hosts. You will also use filters to screen particular types of connections. This is commonly called firewalling your network.

Before creating filter sets, you should read the next few sections to learn more about how these powerful security tools work.

### *What's a filter and what's a filter set?*

A filter is a rule that lets you specify what sort of data can flow in and out of your network. A particular filter can be either an input filter—one that is used on data (packets) coming in to your network from the Internet—or an output filter—one that is used on data (packets) going out from your network to the Internet.

A filter set is a group of filters that work together to check incoming or outgoing data. A filter set can consist of a combination of input and output filters.

### *How filter sets work*

A filter set acts like a team of customs inspectors. Each filter is an inspector through which incoming and outgoing packages must pass. The inspectors work as a team, but each inspects every package individually.

Each inspector has a specific task. One inspector's task may be to examine the destination address of all outgoing packages. That inspector looks for a certain destination—which could be as specific as a street address or as broad as an entire country—and checks each package's destination address to see if it matches that destination.



*A filter inspects data packets like a customs inspector scrutinizing packages.*

### Filter priority

Continuing the customs inspectors analogy, imagine the inspectors lined up to examine a package. If the package matches the first inspector's criteria, the package is either rejected or passed on to its destination, depending on the first inspector's particular orders. In this case, the package is never seen by the remaining inspectors.

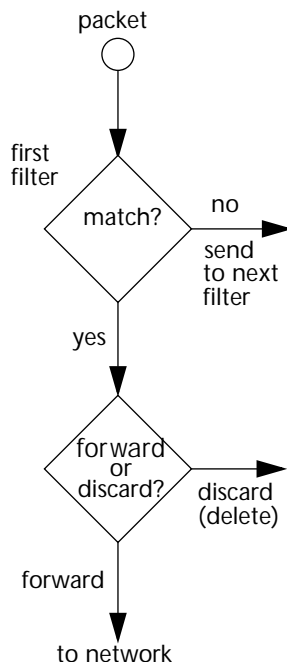

## 11-6 User's Reference Guide

If the package does not match the first inspector's criteria, it goes to the second inspector, and so on. You can see that the order of the inspectors in the line is very important.

For example, let's say the first inspector's orders are to send along all packages that come from Rome, and the second inspector's orders are to reject all packages that come from France. If a package arrives from Rome, the first inspector sends it along without allowing the second inspector to see it. A package from Paris is ignored by the first inspector, rejected by the second inspector, and never seen by the others. A package from London is ignored by the first two inspectors, so it's seen by the third inspector.

In the same way, filter sets apply their filters in a particular order. The first filter applied can forward or discard a packet before that packet ever reaches any of the other filters. If the first filter can neither forward nor discard the packet (because it cannot match any criteria), the second filter has a chance to forward or reject it, and so on. Because of this hierarchical structure, each filter is said to have a priority. The first filter has the highest priority, and the last filter has the lowest priority.

### How individual filters work

As described above, a filter applies criteria to an IP packet and then takes one of three actions:

- Forwards the packet to the local or remote network
- Blocks (discards) the packet
- Ignores the packet

A filter forwards or blocks a packet only if it finds a match after applying its criteria. When no match occurs, the filter ignores the packet.

#### A filtering rule

The criteria are based on information contained in the packets. A filter is simply a rule that prescribes certain actions based on certain conditions. For example, the following rule qualifies as a filter:

Block all Telnet attempts that originate from the remote host 199.211.211.17.

This rule applies to Telnet packets that come from a host with the IP address 199.211.211.17. If a match occurs, the packet is blocked.

Here is what this rule looks like when implemented as a filter on the Netopia 4541/4542:

+ #	--Source IP Addr	--Dest IP Addr	-----Proto	Src.Port	-D.Port	--On?	-Fwd-
1	199.211.211.17	0.0.0.0	TCP	23		Yes	No

To understand this particular filter, look at the parts of a filter.

### Parts of a filter

A filter consists of criteria based on packet attributes. A typical filter can match a packet on any one of the following attributes:

- The source IP address (where the packet was sent from)
- The destination IP address (where the packet is going)
- The type of higher-layer Internet protocol the packet is carrying, such as TCP or UDP

### Port numbers

A filter can also match a packet's port number attributes, but only if the filter's protocol type is set to TCP or UDP, since only those protocols use port numbers. The filter can be configured to match the following:

- The source port number (the port on the sending host that originated the packet)
- The destination port number (the port on the receiving host that the packet is destined for)

By matching on a port number, a filter can be applied to selected TCP or UDP services, such as Telnet, FTP, and World Wide Web. The following tables show a few common services and their associated port numbers:

Internet service	TCP port	Internet service	TCP port
FTP	20/21	Finger	79
Telnet	23	World Wide Web	80
SMTP (mail)	25	News	144
Gopher	70	rlogin	513

Internet service	UDP port	Internet service	UDP port
Who Is	43	AppleTalk Routing Maintenance (at-rtmp)	202
World Wide Web	80	AppleTalk Name Binding (at-nbp)	202
SNMP	161	AURP (AppleTalk)	387
TFTP	69	who	513

### *Port number comparisons*

A filter can also use a comparison option to evaluate a packet's source or destination port number. The comparison options are:

**No Compare:** No comparison of the port number specified in the filter with the packet's port number.

**Not Equal To:** For the filter to match, the packet's port number cannot equal the port number specified in the filter.

**Less Than:** For the filter to match, the packet's port number must be less than the port number specified in the filter.

**Less Than or Equal:** For the filter to match, the packet's port number must be less than or equal to the port number specified in the filter.

**Equal:** For the filter to match, the packet's port number must equal the port number specified in the filter.

**Greater Than:** For the filter to match, the packet's port number must be greater than the port number specified in the filter.

**Greater Than or Equal:** For the filter to match, the packet's port number must be greater than or equal to the port number specified in the filter.

### *Other filter attributes*

There are three other attributes to each filter:

- The filter's order (i.e., priority) in the filter set
- Whether the filter is currently active
- Whether the filter is set to forward packets or to block (discard) packets



## Putting the parts together

When you display a filter set, its filters are displayed as rows in a table:

```

+---#---Source IP Addr---Dest IP Addr-----Proto-Src.Port-D.Port---On?-Fwd--+
+-----+-----+-----+-----+-----+-----+-----+-----+
1 192.211.211.17 0.0.0.0          TCP    0      23      Yes No
2 0.0.0.0        0.0.0.0          TCP    NC     =6000   Yes No
3 0.0.0.0        0.0.0.0          ICMP   --     --      Yes Yes
4 0.0.0.0        0.0.0.0          TCP    NC     >1023   Yes Yes
5 0.0.0.0        0.0.0.0          UDP    NC     >1023   Yes Yes

```

The table's columns correspond to each filter's attributes:

**#:** The filter's priority in the set. Filter number 1, with the highest priority, is first in the table.

**Source IP Addr:** The packet source IP address to match.

**Dest IP Addr:** The packet destination IP address to match.

**Proto:** The protocol to match. This can be entered as a number (see the table below) or as TCP or UDP if those protocols are used.

Protocol	Number to use	Full name
N/A	0	Ignores protocol type
ICMP	1	Internet Control Message Protocol
TCP	6	Transmission Control Protocol
UDP	17	User Datagram Protocol

**Src. Port:** The source port to match. This is the port on the sending host that originated the packet.

**D. Port:** The destination port to match. This is the port on the receiving host for which the packet is intended.

**On?:** Displays **Yes** when the filter is in effect or **No** when it is not.

**Fwd:** Shows whether the filter forwards (**Yes**) a packet or discards (**No**) it when there's a match.

**Filtering example #1**

Returning to our filtering rule example from above (see [page 11-6](#)), look at how a rule is translated into a filter. Start with the rule, then fill in the filter's attributes:

1. The rule you want to implement as a filter is:  
Block all Telnet attempts that originate from the remote host 199.211.211.17.
2. The host 199.211.211.17 is the source of the Telnet packets you want to block, while the destination address is any IP address. How these IP addresses are masked determines what the final match will be, although the mask is not displayed in the table that displays the filter sets (you set it when you create the filter). In fact, since the mask for the destination IP address is 0.0.0.0, the address for Dest IP Addr could have been anything. The mask for Source IP Addr must be 255.255.255.255 since an exact match is desired.
  - Source IP Addr = 199.211.211.17
  - Source IP address mask = 255.255.255.255
  - Dest IP Addr = 0.0.0.0
  - Destination IP address mask = 0.0.0.0
3. Using the tables on [page 11-7](#), find the destination port and protocol numbers (the *local* Telnet port):
  - Proto = TCP (or 6)
  - D. Port = 23
4. The filter should be enabled and instructed to block the Telnet packets containing the source address shown in step 2:
  - On? = Yes
  - Fwd = No

This four-step process is how we produced the following filter from the original rule:

+	#	Source IP Addr	Dest IP Addr	Proto	Src.Port	D.Port	On?	Fwd	+
	1	192.211.211.17	0.0.0.0	TCP	0	23	Yes	No	

**Filtering example #2**

Suppose a filter is configured to block all incoming IP packets with the source IP address of 200.233.14.0, regardless of the type of connection or its destination. The filter would look like this:

+	#	Source IP Addr	Dest IP Addr	Proto	Src.Port	D.Port	On?	Fwd	+
	1	200.233.14.0	0.0.0.0		0		Yes	No	

This filter blocks any packets coming from a remote network with the IP network address 200.233.14.0. The 0 at the end of the address signifies *any* host on the class C IP network 200.233.14.0. If, for example, the filter is applied to a packet with the source IP address 200.233.14.5, it will block it.

In this case, the mask, which does not appear in the table, must be set to 255.255.255.0. This way, all packets with a source address of 200.233.14.x will be matched correctly, no matter what the final address byte is.

**Note:** The protocol attribute for this filter is 0 by default. This tells the filter to ignore the IP protocol or type of IP packet.

## Design guidelines

Careful thought must go into designing a new filter set. You should consider the following guidelines:

- Be sure the filter set's overall purpose is clear from the beginning. A vague purpose can lead to a faulty set, and that can actually make your network *less* secure.
- Be sure each individual filter's purpose is clear.
- Determine how filter priority will affect the set's actions. Test the set (on paper) by determining how the filters would respond to a number of different hypothetical packets.
- Consider the combined effect of the filters. If every filter in a set fails to match on a particular packet, the packet is:
  - Forwarded if all the filters are configured to discard (*not* forward)
  - Discarded if all the filters are configured to forward
  - Discarded if the set contains a combination of forward and discard filters

## Disadvantages of filters

Although using filter sets can greatly enhance network security, there are disadvantages:

- Filters are complex. Combining them in filter sets introduces subtle interactions, increasing the likelihood of implementation errors.
- Enabling a large number of filters can have a negative impact on performance. Processing of packets will take longer if they have to go through many checkpoints.
- Too much reliance on packet filters can cause too little reliance on other security methods. Filter sets are *not* a substitute for password protection, effective safeguarding of passwords, caller ID, the "must match" option in the answer profile, PAP or CHAP in connection profiles, callback, and general awareness of how your network may be vulnerable.

### *An approach to using filters*

The ultimate goal of network security is to prevent unauthorized access to the network without compromising authorized access. Using filter sets is part of reaching that goal.

Each filter set you design will be based on one of the following approaches:

- That which is not expressly prohibited is permitted.
- That which is not expressly permitted is prohibited.

It is strongly recommended that you take the latter, and safer, approach to all of your filter set designs.

---

### *Working with IP filters and filter sets*

This section covers IP filters and filter sets..

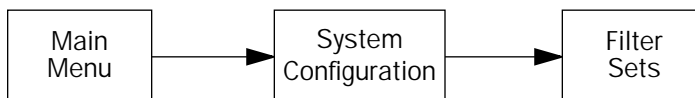

To work with filters and filter sets, begin by accessing the filter set screens.

**Note:** Make sure you understand how filters work before attempting to use them. Read the section [“About filters and filter sets,”](#) beginning on page 11-4.

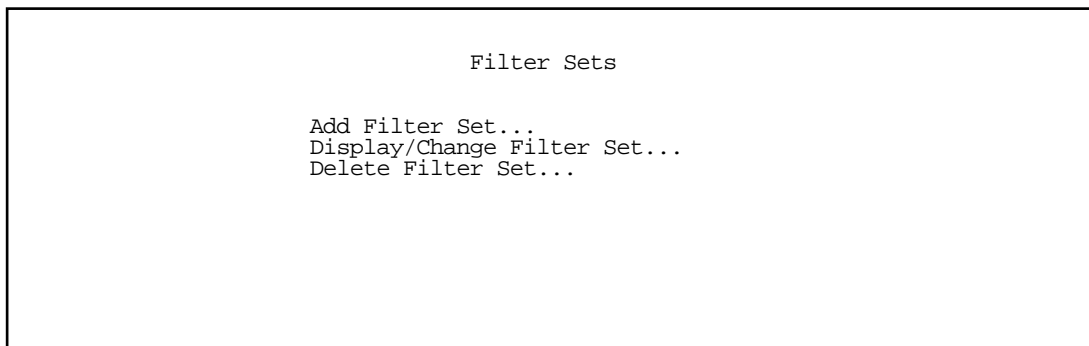

The procedure for creating and maintaining filter sets is as follows:

1. Add a new filter set.
2. Create the filters for the new filter set.
3. View, change, or delete individual filters and filter sets.

The sections below explain how to execute these steps.

### *Adding a filter set*

You can create up to eight different custom filter sets. Each filter set can contain up to 16 output filters and up to 16 input filters.

To add a new filter set, select **Add Filter Set** in the Filter Sets screen and press Return. The Add Filter Set screen appears.

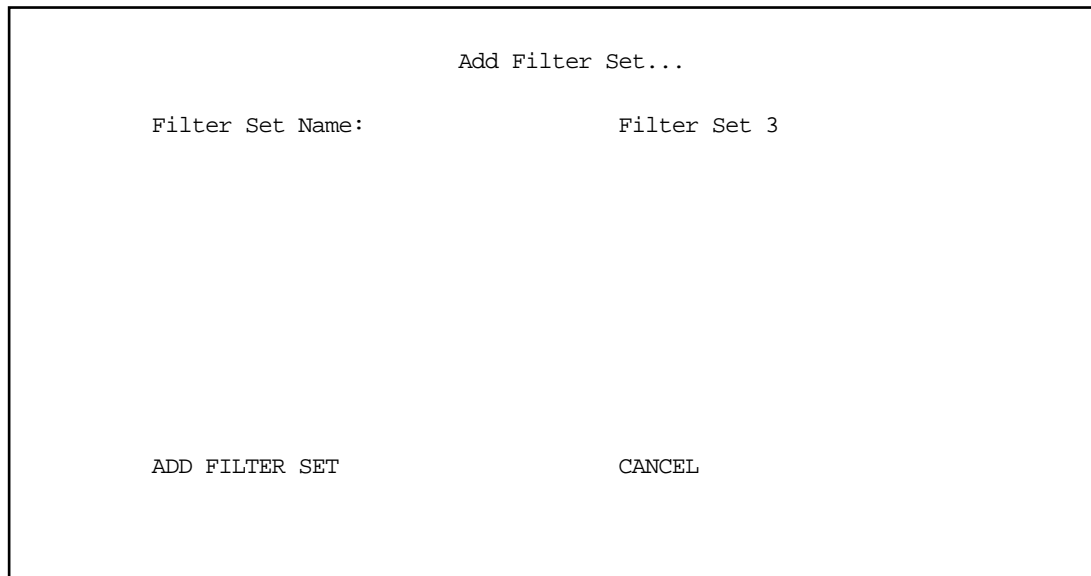

Add Filter Set...

Filter Set Name: Filter Set 3

ADD FILTER SET CANCEL

### *Naming a new filter set*

All new filter sets have a default name. The first filter set you add will be called Filter Set 1, the next filter will be Filter Set 2, and so on.

To give a new filter set a different name, select **Filter Set Name** and enter a new name for the filter set.

To save the filter set, select **ADD FILTER SET**. The saved filter set is empty (contains no filters), but you can return to it later to add filters (see ["Adding filters to a filter set" on page 11-14](#)).

### Adding filters to a filter set

There are two kinds of filters you can add to a filter set: input and output. Input filters check packets received from the Internet, destined for your network. Output filters check packets transmitted from your network to the Internet.

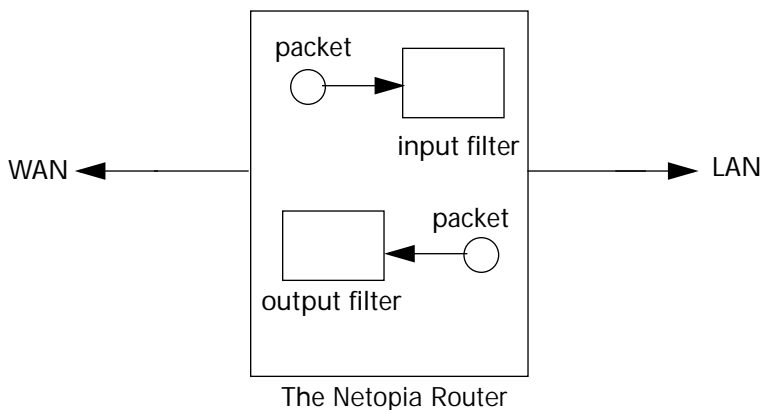

*Packets in the Netopia 4541/4542 pass through an input filter if they originate in the WAN and through an output filter if they're being sent out to the WAN.*

The process for adding input and output filters is exactly the same. The main difference between the two involves their reference to source and destination. From the perspective of an input filter, your local network is the destination of the packets it checks, and the remote network is their source. From the perspective of an output filter, your local network is the source of the packets, and the remote network is their destination.

Type of filter	Source means	Destination means
Input filter	The remote network	The local network
Output filter	The local network	The remote network

To add a filter, select **Display/Change Filter Set** in the Filter Set screen. From the pop-up menu, select the filter set to which you will add a filter. The Display/Change Filter Set screen appears.

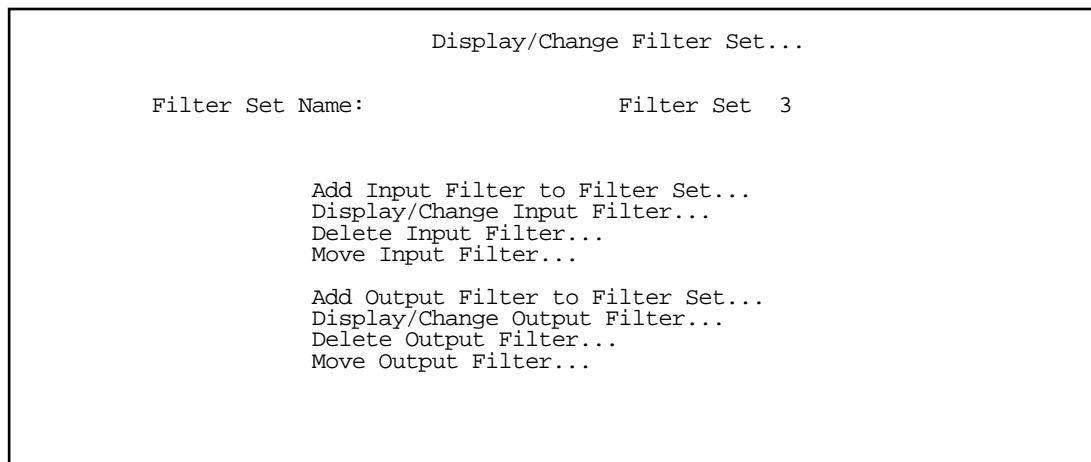

**Note:** There are two groups of items in this screen, one for input filters and one for output filters. In this section, you'll learn how to add an input filter to a filter set. Adding an output filter works exactly the same way, providing you keep the different source and destination perspectives in mind.

1. To add a filter, select **Add Input Filter to Filter Set** and press Return. The Add Input Filter screen appears.

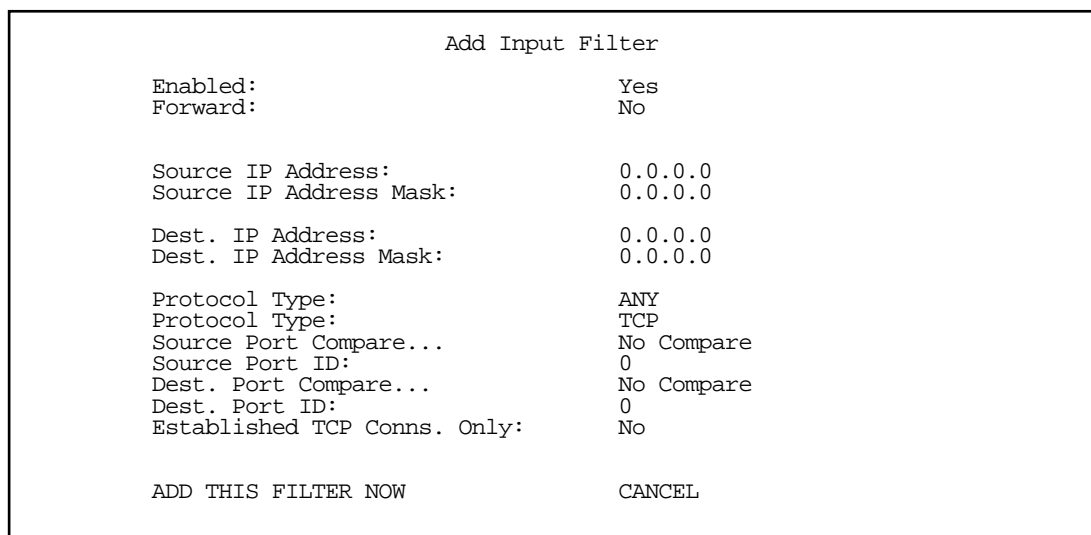

2. To make the filter active in the filter set, select **Enabled** and toggle it to **Yes**. If **Enabled** is toggled to **No**, the filter can still exist in the filter set, but it will have no effect.
3. If you want the filter to forward packets that match its criteria to the destination IP address, select **Forward** and toggle it to **Yes**. If **Forward** is toggled to **No**, packets matching the filter's criteria will be discarded.
4. Select **Source IP Address** and enter the source IP address this filter will match on. You can enter a subnet or a host address.

5. Select **Source IP Address Mask** and enter a mask for the source IP address. This allows you to further modify the way the filter will match on the source address. Enter 0.0.0.0 to force the filter to match on all source IP addresses, or enter 255.255.255.255 to match the source IP address exclusively.
6. Select **Dest. IP Address** and enter the destination IP address this filter will match on. You can enter a subnet or a host address.
7. Select **Dest. IP Address Mask** and enter a mask for the destination IP address. This allows you to further modify the way the filter will match on the destination address. Enter 0.0.0.0 to force the filter to match on all destination IP addresses.
8. Select **Protocol Type** and enter **ICMP, TCP, UDP, Any**, or the number of another IP transport protocol (see the table on [page 11-9](#)).

**Note:** If Protocol Type is set to TCP or UDP, the settings for port comparison that you configure in steps 8 and 9 will appear. These settings only take effect if the Protocol Type is TCP or UDP.

9. Select **Source Port Compare** and choose a comparison method for the filter to use on a packet's source port number. Then select **Source Port ID** and enter the actual source port number to match on (see the table on [page 11-7](#)).
10. Select **Dest. Port Compare** and choose a comparison method for the filter to use on a packet's destination port number. Then select **Dest. Port ID** and enter the actual destination port number to match on (see the table on [page 11-7](#)).
11. When you are finished configuring the filter, select **ADD THIS FILTER NOW** to save the filter in the filter set. Select **CANCEL** to discard the filter and return to the Add IP Filter Set screen.

### *Viewing filters*

To display a table of input or output filters, select **Display/Change Input Filter** or **Display/Change Output Filter** in the Display/Change Filter Set screen.

### *Modifying filters*

To modify a filter, select **Display/Change Input Filter** or **Display/Change Output Filter** in the Display/Change Filter Set screen. Select a filter from the table and press Return. The Change Filter screen appears. The parameters in this screen are set in the same way as the ones in the Add Filter screen (see ["Adding filters to a filter set"](#) on [page 11-14](#)).



Change Filter	
Enabled:	No
Forward:	No
Source IP Address:	0.0.0.0
Source IP Address Mask:	0.0.0.0
Dest. IP Address:	0.0.0.0
Dest. IP Address Mask:	0.0.0.0
Protocol Type:	0
Source Port Compare...	No Compare
Source Port ID:	0
Dest. Port Compare...	No Compare
Dest. Port ID:	0

Enter the IP specific information for this filter.

### Deleting filters

To delete a filter, select **Delete Input Filter** or **Delete Output Filter** in the Display/Change Filter Set screen to display a table of filters.

Select the filter from the table and press Return to delete it. Press Escape to exit the table without deleting the filter.

### Moving filters

To reorganize the filters in a filter set, select **Move Input Filter** or **Move Output Filter** in the Display/Change Filter Set screen to display a table of filters.

Select a filter from the table and press Return. Then use the up or down arrow key to change the filter's order in the filter set. Press Return to accept the new filter location.

### Deleting a filter set

**Note:** If you delete a filter set, all of the filters it contains are deleted as well. To reuse any of these filters in another set, before deleting the current filter set you'll have to note their configuration and then recreate them.

To delete a filter set, select **Delete Filter Set** in the Filter Sets screen to display a list of filter sets.

Select a filter set from the list and press Return. Select CONTINUE and press Return to delete it.

### A sample filter set

This section contains the settings for a filter set called Basic Firewall, which is part of the Netopia 4541/4542's factory configuration.

## 11-18 User's Reference Guide

Basic Firewall blocks undesirable traffic originating from the WAN (in most cases, the Internet), but forwards all traffic originating from the LAN. It follows the conservative "that which is not expressly permitted is prohibited" approach: unless an incoming packet expressly matches one of the constituent input filters, it will not be forwarded to the LAN.

The five input filters and one output filter that make up Basic Firewall are shown in the table below.

Setting	Input filter 1	Input filter 2	Input filter 3	Input filter 4	Input filter 5	Output filter 1
Enabled	Yes	Yes	Yes	Yes	Yes	Yes
Forward	No	No	Yes	Yes	Yes	Yes
Source IP address	0.0.0.0	0.0.0.0	0.0.0.0	0.0.0.0	0.0.0.0	0.0.0.0
Source IP address mask	0.0.0.0	0.0.0.0	0.0.0.0	0.0.0.0	0.0.0.0	0.0.0.0
Dest. IP address	0.0.0.0	0.0.0.0	0.0.0.0	0.0.0.0	0.0.0.0	0.0.0.0
Dest. IP address mask	0.0.0.0	0.0.0.0	0.0.0.0	0.0.0.0	0.0.0.0	0.0.0.0
Protocol type	TCP	TCP	ICMP	TCP	UDP	0
Source port comparison	No Compare	No Compare	N/A	No Compare	No Compare	N/A
Source port ID	0	0	N/A	0	0	N/A
Dest. port comparison	Equal	Equal	N/A	Greater Than	Greater Than	N/A
Dest. port ID	2000	6000	N/A	1023	1023	N/A

Basic Firewall's filters play the following roles.

**Input filters 1 and 2:** These block WAN-originated OpenWindows and X-Windows sessions. Service origination requests for these protocols use ports 2000 and 6000, respectively. Since these are greater than 1023, OpenWindows and X-Windows traffic would otherwise be allowed by input filter 4. Input filters 1 and 2 must precede input filter 4; otherwise they would have no effect since filter 4 would have already forwarded OpenWindows and X-Windows traffic.

**Input filter 3:** This filter explicitly forwards all WAN-originated ICMP traffic to permit devices on the WAN to ping devices on the LAN. Ping is an Internet service that is useful for diagnostic purposes.

**Input filters 4 and 5:** These filters forward all TCP and UDP traffic, respectively, when the destination port is greater than 1023. This type of traffic generally does not allow a remote host to connect to the LAN using one of the potentially intrusive Internet services, such as Telnet, FTP, and WWW.

**Output filter 1:** This filter forwards all outgoing traffic to make sure that no outgoing connections from the LAN are blocked.

Basic Firewall is suitable for a LAN containing only client hosts that want to access servers on the WAN, but not for a LAN containing servers providing services to clients on the WAN. Basic Firewall's general strategy is to explicitly forward WAN-originated TCP and UDP traffic to ports greater than 1023. Ports lower than 1024 are the service origination ports for various Internet services such as FTP, Telnet, and the World Wide Web (WWW).

A more complicated filter set would be required to provide WAN access to a LAN-based server. See the next section, "[Possible modifications](#)," for ways to allow remote hosts to use services provided by servers on the LAN.

### *Possible modifications*

You can modify the sample filter set Basic Firewall to allow incoming traffic using the examples below. These modifications are not intended to be combined. Each modification is to be the only one used with Basic Firewall.

The results of combining filter set modifications can be difficult to predict. It is recommended that you take special care if you are making more than one modification to the sample filter set.

**Trusted host.** To allow unlimited access by a trusted remote host with the IP address a.b.c.d (corresponding to a numbered IP address such as 163.176.8.243), insert the following input filter ahead of the current input filter 1:

- Enabled: Yes
- Forward: Yes
- Source IP Address: a.b.c.d
- Source IP Address Mask: 255.255.255.255
- Dest. IP Address: 0.0.0.0
- Dest. IP Address Mask: 0.0.0.0
- Protocol Type: 0

**Trusted subnet.** To allow unlimited access by a trusted remote subnet with subnet address a.b.c.d (corresponding to a numbered IP address such as 163.176.8.0) and subnet mask e.f.g.h (corresponding to a numbered IP mask such as 255.255.255.0), insert the following input filter ahead of the current input filter 1:

- Enabled: Yes
- Forward: Yes
- Source IP Address: a.b.c.d
- Source IP Address Mask: e.f.g.h
- Dest. IP Address: 0.0.0.0
- Dest. IP Address Mask: 0.0.0.0
- Protocol Type: 0

**FTP sessions.** To allow WAN-originated FTP sessions to a LAN-based FTP server with the IP address a.b.c.d (corresponding to a numbered IP address such as 163.176.8.243), insert the following input filter ahead of the current input filter 1:

- Enabled: Yes
- Forward: Yes
- Source IP Address: 0.0.0.0
- Source IP Address Mask: 0.0.0.0
- Dest. IP Address: a.b.c.d
- Dest. IP Address Mask: 255.255.255.255
- Protocol Type: TCP
- Source Port Comparison: No Compare
- Source Port ID: 0
- Dest. Port Comparison: Equal
- Dest. Port ID: 21

**Note:** A similar filter could be used to permit Telnet or WWW access. Set the Dest. Port ID to 23 for Telnet or to 80 for WWW.

**Note:** Deleting a filter set does not delete the filters in that set. However, the filters in the deleted set are no longer in effect (unless they are part of another set). The deleted set will no longer appear in the answer profile or any connection profiles to which it was added.

---

## *Firewall tutorial*

### *General firewall terms*

**Filter rule:** A filter set is comprised of individual filter rules.

**Filter set:** A grouping of individual filter rules.

**Firewall:** A component or set of components that restrict access between a protected network and the Internet, or between two networks.

**Host:** A workstation on the network.

**Packet:** Unit of communication on the Internet.

**Packet filter:** Packet filters allow or deny packets based on source or destination IP addresses, TCP or UDP ports, or the TCP ACK bit.

**Port:** A number that defines a particular type of service.

## Basic IP packet components

All IP packets contain the same basic header information, as follows:

Source IP Address	163.176.132.18
Destination IP Address	163.176.4.27
Source Port	2541
Destination Port	80
Protocol	TCP
ACK Bit	Yes
DATA	User Data

This header information is what the packet filter uses to make filtering decisions. It is important to note that a packet filter does not look into the IP data stream (the User Data from above) to make filtering decisions.

## Basic protocol types

**TCP:** Transmission Control Protocol. TCP provides reliable packet delivery and has a retransmission mechanism (so packets are not lost). RFC 793 is the specification for TCP.

**UDP:** User Datagram Protocol. Unlike TCP, UDP does not guarantee reliable, sequenced packet delivery. If data does not reach its destination, UDP does not retransmit the data. RFC 768 is the specification for UDP.

There are many more ports defined in the Assigned Addresses RFC. The table that follows shows some of these port assignments.

### Example TCP/UDP Ports

TCP Port	Service
20/21	FTP
23	Telnet
25	SMTP
80	WWW
144	News

UDP Port	Service
161	SNMP

UDP Port	Service
69	TFTP
387	AURP

## *Firewall design rules*

There are two basic rules to firewall design:

- “What is not explicitly allowed is denied.”

and

- “What is not explicitly denied is allowed.”

The first rule is far more secure, and is the best approach to firewall design. It is far easier (and more secure) to allow in or out only certain services and deny anything else. If the other rule is used, you would have to figure out everything that you want to disallow, now and in the future.

### *Firewall Logic*

Firewall design is a test of logic, and filter rule ordering is critical. If a packet is forwarded through a series of filter rules and then the packet matches a rule, the appropriate action is taken. The packet will not forward through the remainder of the filter rules.

For example, if you had the following filter set...

Allow WWW access;

Allow FTP access;

Allow SMTP access;

Deny all other packets.

and a packet goes through these rules destined for FTP, the packet would forward through the first rule (WWW), go through the second rule (FTP), and match this rule; the packet is allowed through.

If you had this filter set for example....

Allow WWW access;

Allow FTP access;

Deny FTP access;

Deny all other packets.

and a packet goes through these rules destined for FTP, the packet would forward through the first filter rule (WWW), match the second rule (FTP), and the packet is allowed through. Even though the next rule is to deny all FTP traffic, the FTP packet will never make it to this rule.

### *Binary representation*

It is easiest when doing filtering to convert the IP address and mask in question to binary. This will allow you to perform the logical AND to determine whether a packet matches a filter rule.

### Logical AND function

When a packet is compared (in most cases) a logical AND function is performed. First the IP addresses and subnet masks are converted to binary and then combined with AND. The rules for the logical use of AND are as follows:

$$0 \text{ AND } 0 = 0$$

$$0 \text{ AND } 1 = 0$$

$$1 \text{ AND } 0 = 0$$

$$1 \text{ AND } 1 = 1$$

For example:

Filter rule:

Deny

IP: 163.176.1.15 BINARY: 10100011.10110000.00000001.00001111

Mask: 255.255.255.255 BINARY: 11111111.11111111.11111111.11111111

Incoming Packet:

IP 163.176.1.15 BINARY: 10100011.10110000.00000001.00001111

If you put the incoming packet and subnet mask together with AND, the result is:

10100011.10110000.00000001.00001111

which matches the IP address in the filter rule and the packet is denied.

### Implied rules

With a given set of filter rules, there is an Implied rule that may or may not be shown to the user. The implied rule tells the filter set what to do with a packet that does not match any of the filter rules. An example of implied rules is as follows:

Implied	Meaning
Y+Y+Y=N	If all filter rules are YES, the implied rule is NO.
N+N+N=Y	If all filter rules are NO, the implied rule is YES.
Y+N+Y=N	If a mix of YES and NO filters, the implied rule is NO.

### Established connections

The TCP header contains one bit called the ACK bit (or TCP Ack bit). This ACK bit appears only with TCP, not UDP. The ACK bit is part of the TCP mechanism that guarantees the delivery of data. The ACK bit is set whenever one side of a connection has received data from the other side. Only the first TCP packet will not have the ACK bit set; once the TCP connection is in place, the remainder of the TCP packets will have the ACK bit set.

The ACK bit is helpful for firewall design and reduces the number of potential filter rules. A filter rule could be created just allowing incoming TCP packets with the ACK bit set, since these packets had to be originated from the local network.

*Example filter set screen*

This is an example of the Netopia filter set screen:

```

Change Input Filter 1

Enabled:                               Yes
Forward:                               No

Source IP Address:                     0.0.0.0
Source IP Address Mask:                 0.0.0.0

Dest. IP Address:                      0.0.0.0
Dest. IP Address Mask:                 0.0.0.0

Protocol Type:                         TCP
Source Port Compare...                 No Compare
Source Port ID:                        0
Dest. Port Compare...                  Equal
Dest. Port ID:                         2000
Established TCP Conns. Only:          No

```

*Filter basics*

In the source or destination IP address fields, the IP address that is entered must be the network address of the subnet. A host address can be entered, but the applied subnet mask must be 32 bits (255.255.255.255).

The Netopia 4541/4542 has the ability to compare source and destination TCP or UDP ports. These options are as follows:

Item	What it means
No Compare	Does not compare TCP or UDP port
Not Equal To	Matches any port other than what is defined
Less Than	Anything less than the port defined
Less Than or Equal	Any port less than or equal to the port defined
Equal	Matches only the port defined
Greater Than or Equal	Matches the port or any port greater
Greater Than	Matches anything greater than the port defined



## Example network

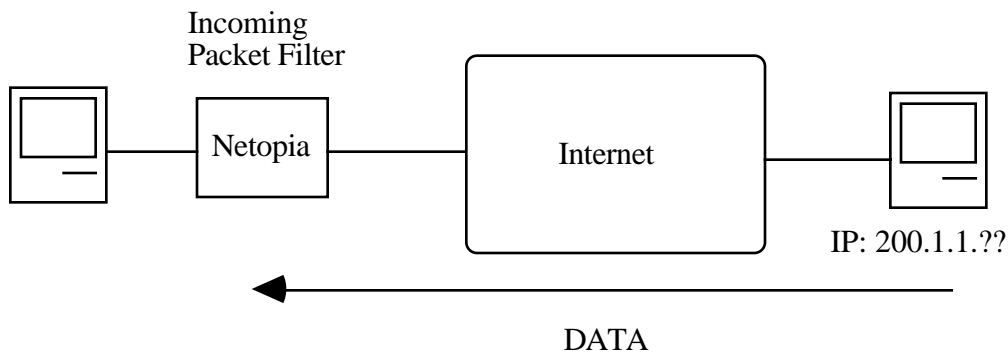

## Example filters

### Example 1

Filter Rule:	200.1.1.0	(Source IP Network Address)
	255.255.255.128	(Source IP Mask)
	Forward = No	(What happens on match)

Incoming packet has the source address of 200.1.1.28

IP Address	Binary Representation	
200.1.1.28	00011100	(Source address in incoming IP packet)
AND		
255.255.255.128	10000000	(Perform the logical AND)
	00000000	(Logical AND result)

This incoming IP packet has a source IP address that matches the network address in the Source IP Address field (00000000) in the Netopia 4541/4542. This will *not* forward this packet.

## Example 2

Filter Rule:	200.1.1.0	(Source IP Network Address)
	255.255.255.128	(Source IP Mask)
	Forward = No	(What happens on match)

Incoming packet has the source address of 200.1.1.184.

IP Address	Binary Representation	
200.1.1.184	10111000	(Source address in incoming IP packet)
AND		
255.255.255.128	10000000	(Perform the logical AND)
	10000000	(Logical AND result)

This incoming IP packet (10000000) has a source IP address that does not match the network address in the Source IP Address field (00000000) in the Netopia 4541/4542. This rule *will* forward this packet because the packet does not match.

## Example 3

Filter Rule:	200.1.1.96	(Source IP Network Address)
	255.255.255.240	(Source IP Mask)
	Forward = No	(What happens on match)

Incoming packet has the source address of 200.1.1.184.

IP Address	Binary Representation	
200.1.1.184	10111000	(Source address in incoming IP packet)
AND		
255.255.255.240	11110000	(Perform the logical AND)
	10110000	(Logical AND result)

Since the Source IP Network Address in the Netopia 4541/4542 is 01100000, and the source IP address after the logical AND is 10110000, this rule does *not* match and this packet will be forwarded.

*Example 4*

Filter Rule:	200.1.1.96	(Source IP Network Address)
	255.255.255.240	(Source IP Mask)
	Forward = No	(What happens on match)

Incoming packet has the source address of 200.1.1.104.

IP Address	Binary Representation	
200.1.1.104	01101000	(Source address in incoming IP packet)
AND		
255.255.255.240	11110000	(Perform the logical AND)
	01100000	(Logical AND result)

Since the Source IP Network Address in the Netopia 4541/4542 is 01100000, and the source IP address after the logical AND is 01100000, this rule *does* match and this packet will *not* be forwarded.

*Example 5*

Filter Rule:	200.1.1.96	(Source IP Network Address)
	255.255.255.255	(Source IP Mask)
	Forward = No	(What happens on match)

Incoming packet has the source address of 200.1.1.96.

IP Address	Binary Representation	
200.1.1.96	01100000	(Source address in incoming IP packet)
AND		
255.255.255.255	11111111	(Perform the logical AND)
	01100000	(Logical AND result)

Since the Source IP Network Address in the Netopia 4541/4542 is 01100000, and the source IP address after the logical AND is 01100000, this rule *does* match and this packet will *not* be forwarded. This rule masks off a *single* IP address.



## Chapter 12

# Monitoring Tools

This chapter discusses the Netopia 4541/4542's device and network monitoring tools. These tools can provide statistical information, report on current network status, record events, and help in diagnosing and locating problems.

This section covers the following topics:

- "Quick View status overview" on page 12-1
- "Statistics & Logs" on page 12-4
- "Event histories" on page 12-4
- "IP Routing Table" on page 12-7
- "General Statistics" on page 12-7
- "System Information" on page 12-9
- "SNMP" on page 12-9

---

### Quick View status overview

You can get a useful, overall status report from the Netopia 4541/4542 in the Quick View screen. To go to the Quick View screen, select **Quick View** in the Main Menu.

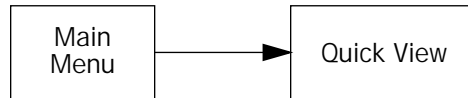

The Quick View screen has three status sections:

- General status
- Current DSL Status
- LED Status

## General status

```

Quick View                                10/11/2001 07:31:26 AM
Default IP Gateway: 0.0.0.0                CPU Load: 4%    Unused Memory: 6044 KB
Primary DNS Server: 0.0.0.0                Domain Name: Netopia.com
Secondary DNS Server: 0.0.0.0

-----MAC Address-----IP Address-----
Ethernet Hub:    00-00-c5-ff-70-00  192.168.1.1
ATM ADSL WAN:   00-00-c5-ff-70-02  0.0.0.0

Current DSL Status
Profile Name-----Rate--%Use-Remote Address-----Est.-More Info-----
ISP                    1536   10 IP 92.163.4.1      Lcl NAT 192.163.100.6

VPN QuickView
                                LED Status
-PWR---ERROR---ETHERNET---DSL- - - - - - - - - - - +-----LEDS-----
  G      -      -      -      | ' '= Off 'G'= Green
                                | 'R'= Red 'Y'= Yellow

```

**Current Date:** The current date; this can be set with the Date and Time utility (see [“Date and time”](#) on page 7-16).

**Default IP Gateway:** The router's default gateway, which may be either manually configured or learned via DHCP. This is the value you assigned in the Default IP Gateway field on [page 6-6](#). If you are using the router's defaults (DHCP and NAT) this value will be 0.0.0.0. If you have assigned an IP address as your default gateway, it is shown here.

**CPU Load:** Percentage of the system's resources being used by all current transmissions.

**Unused Memory:** The total remaining system memory available for use.

**Primary DNS Server:** If you are using the router's defaults (DHCP and NAT) this value will be 0.0.0.0. If you have assigned an IP address as your primary default gateway, it is shown here.

**Secondary DNS Server:** If you are using the router's defaults (DHCP and NAT) this value will be 0.0.0.0. If you have assigned an IP address as a secondary gateway, it is shown here.

**Domain Name:** The domain name you have assigned, typically the name of your ISP.

**MAC Address:** The Netopia 4541/4542's hardware address, for those interfaces that support DHCP.

**IP Address:** The Netopia 4541/4542's IP address, entered in the IP Setup screen.

## Current status

The current status section is a table showing the current status of the DSL connection. For example:

```

Current DSL Status
Profile Name-----Rate--%Use-Remote Address-----Est.-More Info-----
ISP                1536  10 IP 92.163.4.1      Lcl NAT 192.163.100.6

```

**Profile Name:** Lists the name of the connection profile being used, if any.

**Rate:** Shows the line rate for this connection.

**%Use:** Indicates the average percent utilization of the maximum capacity of the channels in use for the connection.

**Remote Address:** Shows the IP address of the connected remote router.

**Est:** Indicates whether the connection was locally ("Lcl") or remotely ("Rmt") established.

**More Info:** Indicates the NAT address in use for this connection.

## Status lights

This section shows the current real-time status of the Netopia 4541/4542's status lights (LEDs). It is useful for remotely monitoring the router's status. The Quick View screen's arrangement of LEDs corresponds to the physical arrangement of LEDs on the router.

```

LED Status
-PWR---ERROR---ETHERNET---DSL- - - - - +-----LEDS-----
G      -      -      -      | '- '= Off 'G'= Green
                                | 'R'= Red 'Y'= Yellow

```

Each LED representation can report one of four states:

–: The LED is off.

**R:** The LED is red.

**G:** The LED is green.

**Y:** The LED is yellow.

The section ["Netopia 4541/4542 ADSL Router status lights"](#) on page 2-3 describes the meanings of the colors for each LED.

## Statistics & Logs

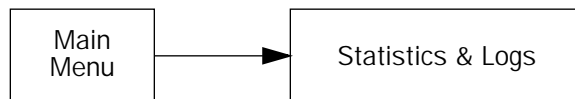

When you are troubleshooting your Netopia 4541/4542, the Statistics & Logs screens provide insight into the recent event activities of the router.

From the Main Menu go to Statistics & Logs and select one of the options described in the sections below.

---

## Event histories



The Netopia 4541/4542 records certain relevant occurrences in event histories. Event histories are useful for diagnosing problems because they list what happened before, during, and after a problem occurs. You can view two different event histories: one for the router's system and one for the WAN. The Netopia 4541/4542's built-in battery backup prevents loss of event history from a shutdown or reset.

The router's event histories are structured to display the most recent events first, and to make it easy to distinguish error messages from informational messages. Error messages are prefixed with an asterisk. Both the WAN Event History and Device Event History retain records of the 128 most recent events.

In the Statistics & Logs screen, select **WAN Event History** or **Device Event History**.



## WAN Event History

The WAN Event History screen lists a total of 128 events on the WAN. The most recent events appear at the top.

```

                                WAN Event History
                                Current Date -- 10/11/2001 03:02:23 PM
-Date----Time----Event-----
-----SCROLL UP-----
07/03/98 13:59:06   DSL: IP up, channel 1, gateway: 173.166.107.1
07/03/98 13:59:05   DSL: Channel 1 up
07/03/98 13:59:05   >>WAN: data link activated at 1040 Kbps
07/03/98 13:58:32   --Device restarted-----
07/03/98 12:46:39   --Device restarted-----
07/03/98 11:45:57   --Device restarted-----
07/02/98 17:58:15   DSL: IP up, channel 1, gateway: 173.166.107.1
07/02/98 17:58:10   DSL: Channel 1 up
07/02/98 17:58:10   >>WAN: data link activated at 1040 Kbps
07/02/98 17:57:05   DSL: IP down, channel 1
07/02/98 17:57:05   Link 1 down: No Synch
07/02/98 17:57:05   >>WAN: data link deactivated
07/02/98 17:48:02   DSL: IP up, channel 1, gateway: 173.166.107.1
07/02/98 17:48:01   DSL: Channel 1 up
-----SCROLL DOWN-----
Clear History...

Return/Enter on event item for details or SCROLL [UP/DOWN] item for scrolling.

```

Each entry in the list contains the following information:

**Date:** Date of the event.

**Time:** Time of the event.

**Event:** A brief description of the event.

**Ch.:** The channel involved in the event.

The first event in each call sequence is marked with double arrows (>>).

Failures are marked with an asterisk (\*).

If the event history exceeds the size of the screen, you can scroll through it by using the SCROLL UP and SCROLL DOWN items.

To scroll up, select **SCROLL UP** at the top of the list and press Return. To scroll down, select **SCROLL DOWN** at the bottom of the list and press Return.

To get more information about any event listed in the WAN Event History, select the event and then press Return. A dialog box containing more information about the selected event will appear. Press Return or Escape to dismiss the dialog box.

To clear the event history, select **Clear History** at the bottom of the history screen and press Return.

## Device Event History

The Device Event History screen lists a total of 128 port and system events, giving the time and date for each event, as well as a brief description. The most recent events appear at the top.

In the Statistics & Logs screen, select **Device Event History**. The Device Event History screen appears.

```

                                Device Event History
                                Current Date -- 10/11/2001 03:02:23 PM
-Date----Time----Event-----
-----SCROLL UP-----
01/22/96 02:03:11  IP address server initialization complete
01/22/96 02:03:11 --BOOT: Warm start v4.3
01/22/96 02:02:32  IP address server initialization complete
01/22/96 02:02:32 --BOOT: Warm start v4.3
01/22/96 01:59:50 * IP: Route 0.0.0.0/0.0.0.0 not installed
01/22/96 01:59:50  IP address server initialization complete
01/22/96 01:59:50 --BOOT: Cold start v4.3
01/22/96 01:55:07 * IP: Route 0.0.0.0/0.0.0.0 not installed
-----SCROLL DOWN-----
Clear History...

Return/Enter on event item for details or SCROLL [UP/DOWN] item for scrolling.

```

If the event history exceeds the size of the screen, you can scroll through it by using **SCROLL UP** and **SCROLL DOWN**.

To scroll up, select **SCROLL UP** at the top of the list and press Return. To scroll down, select **SCROLL DOWN** at the bottom of the list and press Return.

To obtain more information about any event listed in the Device Event History, select the event and then press Return. A dialog box containing more information about the selected event appears. Press Return or Escape to dismiss the dialog box.

To clear the Device Event History, select **Clear History** and press Return.

## IP Routing Table



The IP routing table displays all of the IP routes currently known to the Netopia 4541/4542.

IP Routing Table					
Network Address	Subnet Mask	via Router	Port	Type	
-----SCROLL UP-----					
0.0.0.0	255.0.0.0	0.0.0.0	--	Other	
127.0.0.1	255.255.255.255	127.0.0.1	Loopback	Local	
192.168.1.0	255.255.255.240	192.168.1.1	Ethernet	Local	
192.168.1.1	255.255.255.255	192.168.1.1	Ethernet	Local	
192.168.1.15	255.255.255.255	192.168.1.15	Ethernet	Bcast	
224.0.0.0	224.0.0.0	0.0.0.0	--	Other	
255.255.255.255	255.255.255.255	255.255.255.255	--	Bcast	
-----SCROLL DOWN-----					
UPDATE					

The routing table screen represents a snapshot of the routing table information at the time the screen is first invoked. To take a new snapshot, select **Update** at the bottom of the screen and press Return.

## General Statistics

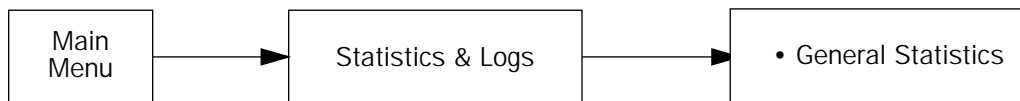

The General Statistics screen displays information about data traffic on the Netopia 4541/4542's data ports. This information is useful for monitoring and troubleshooting your LAN. Note that the counters roll over at their maximum field width, that is, they restart again at 0.

General Statistics						
Physical I/F	Rx Bytes	Tx Bytes	Rx Pkts	Tx Pkts	Rx Err	Tx Err
Ethernet Hub	1234567	123456	123456	123456	123456	12345
ATM ADSL 1	1234567	123456	123456	123456	123456	12345

Network	Rx Bytes	Tx Bytes	Rx Pkts	Tx Pkts	Rx Err	Tx Err
IP	1234567	123456	123456	123456	123456	12345

VC Traffic Statistics...

### Physical Interface

The top left side of the screen lists total packets received and total packets transmitted for the following data ports:

- Ethernet
- DSL

### Network Interface

The bottom left side of the screen lists total packets received and total packets transmitted:

- IP (IP packets on the Ethernet)

The right side of the table lists the total number of occurrences of each of six types of communication statistics:

**Rx Bytes:** The number of bytes received

**Tx Bytes:** The number of bytes transmitted

**Rx Packets:** The number of packets received

**Tx Pkts:** The number of packets transmitted

**Rx Err:** The number of bad Ethernet packets received

**Tx Err:** The number of errors occurring when Ethernet packets are transmitted simultaneously by nodes on the LAN

---

## System Information

The System Information screen gives a summary view of the general system level values in the Netopia 4541/4542.

From the Statistics & Logs menu select **System Information**. The System Information screen appears.

System Information	
Serial Number	ff-70-00 (16740352)
Firmware Version	50d70
Processor Speed (MHz)	50
Flash ROM Capacity (MBytes)	2
DRAM Capacity (MBytes)	16
Ethernet	Single 10/100 Port
WAN Interface	ATM ADSL

The information display varies by model, firmware version, feature set, and so on. You can tell at a glance your particular system configuration.

---

## SNMP

The Netopia 4541/4542 includes a Simple Network Management Protocol (SNMP) agent, allowing monitoring and configuration by a standard SNMP manager.

The Netopia 4541/4542 supports the following management information base (MIB) documents:

- MIB II (RFC 1213)
- Interface MIB (RFC 1229)
- Ethernet MIB (RFC 1643)
- Netopia MIB

These MIBs are on the Netopia CustomerCare CD included with the Netopia 4541/4542. Load these MIBs into your SNMP management software in the order they are listed here. Follow the instructions included with your SNMP manager on how to load MIBs.

## The SNMP Setup screen

From the Main Menu, select **SNMP** in the System Configuration screen and press Return. The SNMP Setup screen appears.

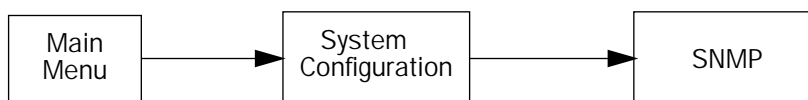

```
SNMP Setup

System Name:
System Location:
System Contact:

Read-Only Community String:      public
Read/Write Community String:     private
Authentication Traps Enable:     Off
IP Trap Receivers...

Configure optional SNMP parameters from here.
```

Follow these steps to configure the first three items in the screen:

1. Select **System Name** and enter a descriptive name for the Netopia 4541/4542's SNMP agent.
2. Select **System Location** and enter the router's physical location (room, floor, building, etc.).
3. Select **System Contact** and enter the name of the person responsible for maintaining the router.

System Name, System Location, and System Contact set the values returned by the Netopia 4541/4542 SNMP agent for the SysName, SysLocation, and SysContact objects, respectively, in the MIB II system group. Although optional, the information you enter in these items can help a system administrator manage the network more efficiently.

### Community strings

The **Read-Only Community String** and the **Read/Write Community String** are like passwords that must be used by an SNMP manager querying or configuring the Netopia 4541/4542. An SNMP manager using the **Read-Only Community String** can examine statistics and configuration information from the router, but cannot modify the router's configuration. An SNMP manager using the **Read/Write Community String** can both examine and modify configuration parameters.

By default, the read-only and read/write community strings are set to public and private, respectively. You should change both of the default community strings to values known only to you and trusted system administrators.

To change a community string, select it and enter a new value.

Starting with the version 4.3 firmware, setting the Read-Only and Read-Write community strings to the empty string will block all SNMP requests to the router. (The router may still send SNMP Traps if those are properly enabled.)

Previously, if either community string was the empty string, SNMP Requests specifying an empty community string were accepted and processed.

This change is designed to allow the administrator to block SNMP access to the router and to provide more granular control over the allowed SNMP operations to the router.

- Setting only the Read-Write community string to the empty string will block SNMP Set Requests to the router, but Get Requests and Get-Next Requests will still be honored using the Read-Only community string (assuming that is not the empty string).
- Setting only the Read-Only community string to the empty string will *not* block Get Requests or Get-Next Requests since those operations (and Set Requests) are still allowed using the (non-empty) Read-Write community string.

Even if you decide not to use SNMP, you should change the community strings. This prevents unauthorized access to the Netopia 4541/4542 through SNMP. For more information on security issues, see [“Suggested security measures” on page 11-1](#).

## SNMP traps

An SNMP trap is an informational message sent from an SNMP agent (in this case, the Netopia 4541/4542) to a manager. When a manager receives a trap, it may log the trap as well as generate an alert message of its own.

Standard traps generated by the Netopia 4541/4542 include the following:

- An authentication failure trap is generated when the router detects an incorrect community string in a received SNMP packet. **Authentication Traps Enable** must be **On** for this trap to be generated.
- A cold start trap is generated after the router is reset.
- An interface down trap (ifDown) is generated when one of the router’s interfaces, such as a port, stops functioning or is disabled.
- An interface up trap (ifUp) is generated when one of the router’s interfaces, such as a port, begins functioning.

The Netopia 4541/4542 sends traps using UDP (for IP networks).

You can specify which SNMP managers are sent the IP traps generated by the Netopia 4541/4542. Up to eight receivers can be set. You can also review and remove IP traps.

To go to the IP Trap Receivers screen, select **IP Trap Receivers**. The IP Trap Receivers screen appears.

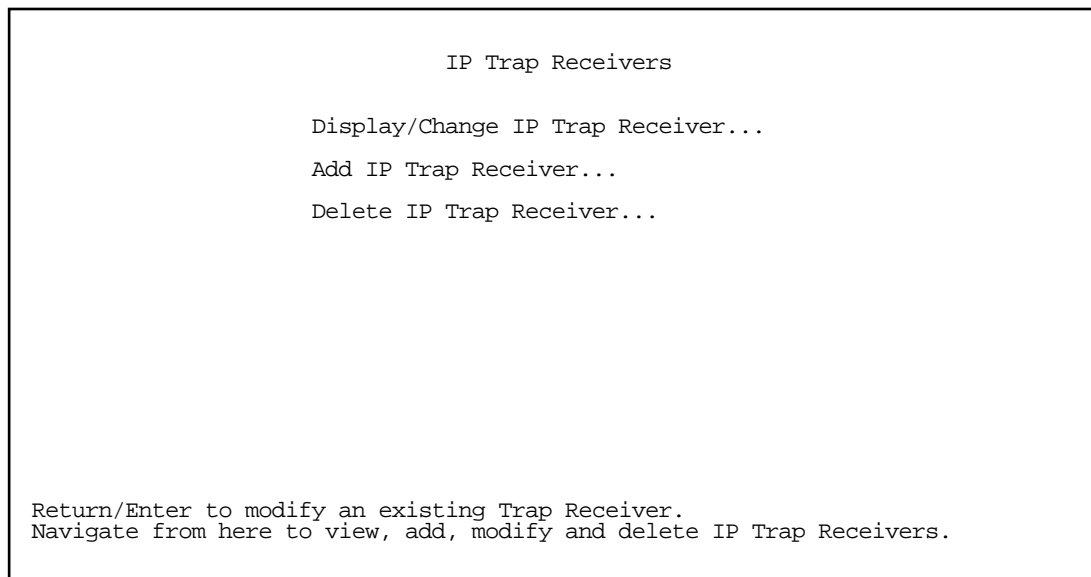

### *Setting the IP trap receivers*

1. Select **Add IP Trap Receiver**.
2. Select **Receiver IP Address or Domain Name**. Enter the IP address or domain name of the SNMP manager you want to receive the trap.
3. Select **Community String** if you enabled one in the SNMP Setup screen, and enter the appropriate password.
4. Select **Add Trap Receiver Now** and press Return. You can add up to seven more receivers.

### *Viewing IP trap receivers*

To display a view-only table of IP trap receivers, select **Display/Change IP Trap Receiver** in the IP Trap Receivers screen.

### *Modifying IP trap receivers*

1. To edit an IP trap receiver, select **Display/Change IP Trap Receiver** in the IP Trap Receivers screen.
2. Select an IP trap receiver from the table and press Return.
3. In the **Change IP Trap Receiver** screen, edit the information as needed and press Return.

### *Deleting IP trap receivers*

1. To delete an IP trap receiver, select **Delete IP Trap Receiver** in the IP Trap Receivers screen.
2. Select an IP trap receiver from the table and press Return.
3. In the dialog box, select **Continue** and press Return.



## Chapter 13

# Utilities and Diagnostics

A number of utilities and tests are available for system diagnostic and control purposes.

This section covers the following topics:

- “Ping” on page 13-2
- “Trace Route” on page 13-4
- “Telnet client” on page 13-5
- “Factory defaults” on page 13-6
- “Transferring configuration and firmware files with TFTP” on page 13-7
- “Transferring configuration and firmware files with XMODEM” on page 13-9
- “Restarting the system” on page 13-12

**Note:** These utilities and tests are accessible only through the console-based management screens. See [Chapter 5, “Console-Based Management,”](#) for information on accessing the console-based management screens.

You access the Utilities & Diagnostics screens from the Main Menu.

```
Utilities & Diagnostics

Ping...
Trace Route...
Telnet...

Trivial File Transfer Protocol (TFTP)...
X-Modem File Transfer...

Restart System...           Revert to Factory Defaults...
```

## Ping

The Netopia 4541/4542 Router includes a standard Ping test utility. A Ping test generates IP packets destined for a particular (Ping-capable) IP host. Each time the target host receives a Ping packet, it returns a packet to the original sender.

Ping allows you to see whether a particular IP destination is reachable from the Netopia 4541/4542. You can also ascertain the quality and reliability of the connection to the desired destination by studying the Ping test's statistics.

In the Utilities & Diagnostic screen, select **Ping** and press Return. The ICMP Ping screen appears.

```

                                ICMP Ping

Name of Host to Ping:
Packets to Send:                5
Data Size:                      56
Delay (seconds):                1

                                START PING

Status:

Packets Out:                    0
Packets In:                     0
Packets Lost:                   0 (0%)
Round Trip Time
  (Min/Max/Avg):                0.000 / 0.000 / 0.000 secs

Enter the IP Address/Domain Name of a host to ping.
Send ICMP Echo Requests to a network host.
```

To configure and initiate a Ping test, follow these steps:

1. Select **Name of Host to Ping** and enter the destination domain name or IP address.
2. Select **Packets to Send** to change the default setting. This is the total number of packets to be sent during the Ping test. The default setting is adequate in most cases, but you can change it to any value from 1 to 4,294,967,295.
3. Select **Data Size** to change the default setting. This is the size, in bytes, of each Ping packet sent. The default setting is adequate in most cases, but you can change it to any value from 0 (only header data) to 1664.
4. Select **Delay (seconds)** to change the default setting. The delay, in seconds, determines the time between Ping packets sent. The default setting is adequate in most cases, but you can change it to any value from 0 to 4,294,967. A delay of 0 seconds forces packets to be sent immediately, one after another.
5. Select **START PING** and press Return to begin the Ping test. While the test is running, the **START PING** item becomes **STOP PING**. To manually stop the Ping test, select **STOP PING** and press Return or Escape.

While the Ping test is running and when it is over, a status field and a number of statistical items are active on the screen. These are described below.

**Status:** The current status of the Ping test. This item can display the status messages shown in the table below:

Message	Description
Resolving host name	Finding the IP address for the domain name-style address
Can't resolve host name	IP address can't be found for the domain name-style address
Pinging	Ping test is in progress
Complete	Ping test was completed
Cancelled by user	Ping test was cancelled manually
Destination unreachable from w.x.y.z	Ping test was able to reach the router with IP address w.x.y.z, which reported that the test could not reach the final destination
Couldn't allocate packet buffer	Couldn't proceed with Ping test; try again or reset system
Couldn't open ICMP port	Couldn't proceed with Ping test; try again or reset system

**Packets Out:** The number of packets sent by the Ping test.

**Packets In:** The number of return packets received from the target host. To be considered on time, return packets are expected back before the next packet in the sequence of Ping packets is sent. A count of the number of late packets appears in parentheses to the right of the **Packets In** count.

In the example that follows, a Netopia 4541/4542 is sending Ping packets to another host, which responds with return Ping packets. Note that the second return Ping packet is considered to be late because it is not received by the Netopia 4541/4542 before the third Ping packet is sent. The first and third return Ping packets are on time.

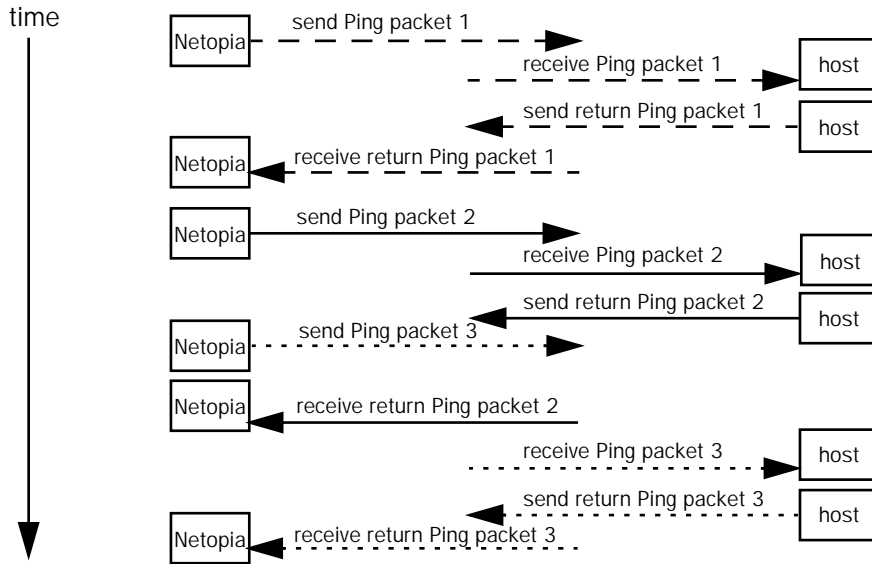

**Packets Lost:** The number of packets unaccounted for, shown in total and as a percentage of total packets sent. This statistic may be updated during the Ping test, and may not be accurate until after the test is over. However, if an escalating one-to-one correspondence is seen between **Packets Out** and **Packets Lost**, and **Packets In** is noticeably lagging behind **Packets Out**, the destination is probably unreachable. In this case, use **STOP PING**.

**Round Trip Time (Min/Max/Avg):** Statistics showing the minimum, maximum, and average number of seconds elapsing between the time each Ping packet was sent and the time its corresponding return Ping packet was received.

The time-to-live (TTL) value for each Ping packet sent by the Netopia 4541/4542 is 255, the maximum allowed. The TTL value defines the number of IP routers that the packet can traverse. Ping packets that reach their TTL value are dropped, and a "destination unreachable" notification is returned to the sender (see the table on the previous page). This ensures that no infinite routing loops occur. The TTL value can be set and retrieved using the SNMP MIB-II ip group's ipDefaultTTL object.

---

## Trace Route

You can count the number of routers between your Netopia Router and a given destination with the Trace Route utility.

In the Statistics & Diagnostics screen, select **Trace Route** and press Return. The Trace Route screen appears.

```

                                Trace Route

Host Name or IP Address:

Maximum Hops:                    30
Timeout (seconds):               5

Use Reverse DNS:                  Yes

                                START TRACE ROUTE

Enter the IP Address/Domain Name of a host.
Trace route to a network host.

```

To trace a route, follow these steps:

1. Select **Host Name or IP Address** and enter the name or address of the destination you want to trace.
2. Select **Maximum Hops** to set the maximum number of routers to count between the Netopia Router and the destination router, up to the maximum of 64. The default is 30 hops.
3. Select **Timeout (seconds)** to set when the trace will timeout for each hop, up to 10 seconds. The default is 3 seconds.
4. Select **Use Reverse DNS** to learn the names of the routers between the Netopia Router and the destination router. The default is Yes.
5. Select **START TRACE ROUTE** and press Return. A scrolling screen will appear that lists the destination, number of hops, IP addresses of each hop, and DNS names, if selected.
6. Cancel the trace by pressing Escape. Return to the Trace Route screen by pressing Escape twice.

---

## *Telnet client*

The Telnet client mode replaces the normal menu mode. Telnet sessions can be cascaded, that is, you can initiate a Telnet client session when using a Telnet console session. To activate the Telnet client, select **Telnet** from the Utilities & Diagnostics menu.

The Telnet client screen appears.

```
Telnet
Host Name or IP Address:
Control Character to Suspend:      Q
START A TELNET SESSION
Resume Suspended Session...
Terminate Suspended Session...
```

- Enter the host name or the IP address in dotted decimal format of the machine you want to Telnet into and press Return.
- Either accept the default control character "Q" used to suspend the Telnet session, or type a different one.
- **START A TELNET SESSION** becomes highlighted.
- Press Return and the Telnet session will be initiated.
- To suspend the session, press Control-Q or whatever other control character you specified.
- To go back to your Telnet session, select **Resume Suspended Session**. Select a session from the pop-up menu and press Return.
- To end a suspended session, select **Terminate Suspended Session**. Select a session from the pop-up menu and press Return.

---

## Factory defaults

You can reset the Netopia 4541/4542 to its factory default settings. In the Utilities & Diagnostics screen, select **Revert to Factory Defaults** and press Return. Select **CONTINUE** in the dialog box and press Return. The Netopia 4541/4542 will reboot and its settings will return to the factory defaults, deleting your configurations.

In an emergency, you can also use the Reset switch to return the router to its factory default settings. Call Netopia Technical Support for instructions on using the Reset switch.

**Note:** Reset to factory defaults with caution. You will need to reconfigure all of your settings in the router.

If you lose your password and are unable to access the console screens, you can manually reset the router in an emergency. See [Appendix A, "Troubleshooting."](#)

## Transferring configuration and firmware files with TFTP

Trivial File Transfer Protocol (TFTP) is a method of transferring data over an IP network. TFTP is a client-server application, with the router as the client. To use the Netopia 4541/4542 as a TFTP client, a TFTP server must be available. Netopia, Inc., has a public access TFTP server on the Internet where you can obtain the latest firmware versions.

To use TFTP, select **Trivial File Transfer Protocol (TFTP)** in the Statistics & Diagnostics screen and press Return. The Trivial File Transfer Protocol (TFTP) screen appears.

```
Trivial File Transfer Protocol (TFTP)

TFTP Server Name:
Firmware File Name:
GET ROUTER FIRMWARE FROM SERVER...

Config File Name:
GET CONFIG FROM SERVER...
SEND CONFIG TO SERVER...

TFTP Transfer State -- Idle
TFTP Current Transfer Bytes -- 0
```

The sections below describe how to update the Netopia 4541/4542's firmware and how to download and upload configuration files.

### Updating firmware

Firmware updates may be available periodically from Netopia or from a site maintained by your organization's network administrator.

The Netopia 4541/4542 ships with an embedded operating system referred to as firmware. The firmware governs how the device communicates with your network and the WAN or remote site. Firmware updates are periodically posted on the Netopia website.

To update the router's firmware, follow these steps:

- Select **TFTP Server Name** and enter the server name or IP address of the TFTP server you will use. The server name or IP address is available from the site where the server is located.
- Select **Firmware File Name** and enter the name of the file you will download. The name of the file is available from the site where the server is located. You may need to enter a file path along with the file name (for example, bigroot/config/myfile).

- Select **GET ROUTER FIRMWARE FROM SERVER** and press Return. You will see the following dialog box:

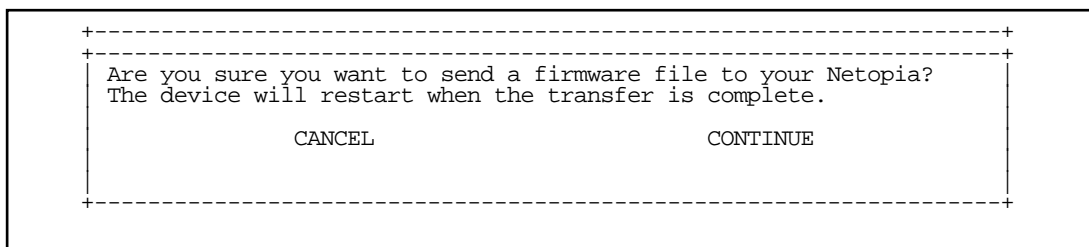

- Select **CANCEL** to exit without downloading the file, or select **CONTINUE** to download the file. The system will reset at the end of the file transfer to put the new firmware into effect. While the system resets, the LEDs will blink on and off.

### **Caution!**

- Be sure the firmware update you load onto your router is the correct version for your particular model. Some models do not support all firmware versions. Loading an incorrect firmware version can permanently damage the unit.
- Do not manually power down or reset the Netopia 4541/4542 while it is automatically resetting or it could be damaged.
- If you choose to download the firmware, the **TFTP Transfer State** item will change from **Idle** to **Reading Firmware**. The **TFTP Current Transfer Bytes** item will reflect the number of bytes transferred.

## *Downloading configuration files*

The Netopia 4541/4542 can be configured by downloading a configuration file using TFTP. Once downloaded, the file reconfigures all of the router's parameters as if someone had manually done so through the console port.

To download a configuration file, follow these steps:

- Select **TFTP Server Name** and enter the server name or IP address of the TFTP server you will use. The server name or IP address is available from the site where the server is located.
- Select **Config File Name** and enter the name of the file you will download. The name of the file is available from the site where the server is located. You may need to enter a file path along with the file name (for example, bigroot/config/myfile).



- Select **GET CONFIG FROM SERVER** and press Return. You will see the following dialog box:

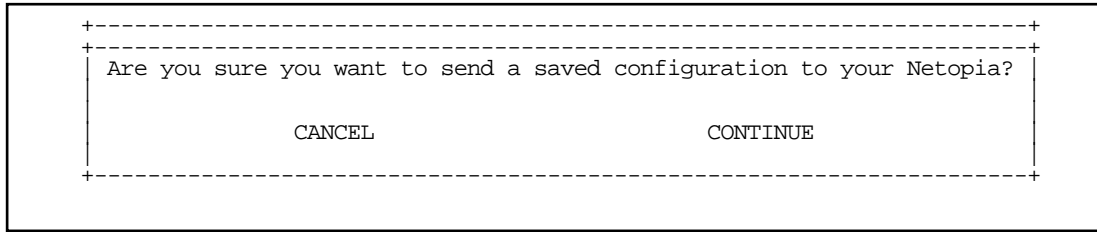

- Select **CANCEL** to exit without downloading the file, or select **CONTINUE** to download the file. The system will reset at the end of the file transfer to put the new configuration into effect.
- If you choose to download the configuration file, the **TFTP Transfer State** item will change from **Idle** to **Reading Config**. The **TFTP Current Transfer Bytes** item will reflect the number of bytes transferred.

## Uploading configuration files

Using TFTP, you can send a file containing a snapshot of the router's current configuration to a TFTP server. The file can then be downloaded by a different Netopia 4541/4542 unit to configure its parameters (see "Downloading configuration files" on page 13-8). This is useful for configuring a number of routers with identical parameters or just for creating configuration backup files.

Uploading a file can also be useful for troubleshooting purposes. The uploaded configuration file can be tested on a different Netopia 4541/4542 unit by Netopia or your network administrator.

To upload a configuration file, follow these steps:

1. Select **TFTP Server Name** and enter the server name or IP address of the TFTP server you will use. The server name or IP address is available from the site where the server is located.
2. Select **Config File Name** and enter a name for the file you will upload. The file will appear with the name you choose on the TFTP server. You may need to enter a file path along with the file name (for example, Mypc/Netopia/myfile).
3. Select **SEND CONFIG TO SERVER** and press Return. Netopia will begin to transfer the file.
4. The **TFTP Transfer State** item will change from **Idle** to **Writing Config**. The **TFTP Current Transfer Bytes** item will reflect the number of bytes transferred.

---

## Transferring configuration and firmware files with XMODEM

You can transfer configuration and firmware files with XMODEM through the Netopia 4541/4542's console port. Be sure your terminal emulation program supports XMODEM file transfers.

To go to the **X-Modem File Transfer** screen, select it in the Utilities & Diagnostics menu.

**Note:** The X-Modem File Transfer screen is only available if you are connected via the Console port.

**Note:** It is good practice when updating programmable devices to disable any other programs or network activity on the device or the attached computer. This includes WAN traffic such as a DSL connection or screen savers or other automatic programs running on the attached computer. Such activity can slow down or interrupt the file transfer requiring you to rerun the upgrade.

```
                                X-Modem File Transfer

Send Firmware to Netopia...

Send Config to Netopia...

Receive Config from Netopia...
```

## Updating firmware

Firmware updates may be available periodically from Netopia or from a site maintained by your organization's network administration.

Follow these steps to update the Netopia 4541/4542's firmware:

1. Make sure you have the firmware file on disk and know the path to its location.
2. Select **Send Firmware to Netopia** and press Return. The following dialog box appears:

```
+-----+
|                                             |
| Are you sure you want to send a firmware file to your Netopia? |
| If so, when you hit Return/Enter on the CONTINUE button, you will |
| have 10 seconds to begin the transfer from your terminal program. |
|                                             |
|          CANCEL          CONTINUE          |
|                                             |
+-----+
```

3. Select **CANCEL** to exit without downloading the file, or select **CONTINUE** to download the file.

If you choose CONTINUE, you will have ten seconds to use your terminal emulation software to initiate an XMODEM transfer of the firmware file. If you fail to initiate the transfer in that time, the dialog box will disappear and the terminal emulation software will inform you of the transfer's failure. You can then try again.

The system will reset at the end of a successful file transfer to put the new firmware into effect. While the system resets, the LEDs will blink on and off.

**Caution!**

Do not manually power down or reset the Netopia 4541/4542 while it is automatically resetting or it could be damaged.

**Downloading configuration files**

The Netopia 4541/4542 can be configured by downloading a configuration file. The downloaded file reconfigures all of the Router's parameters.

Configuration files are available from a site maintained by your organization's network administrator or from your local site (see "Uploading configuration files," below).

Follow these steps to download a configuration file:

1. Make sure you have the configuration file on disk and know the path to its location.
2. Select **Send Config to Netopia** and press Return. The following dialog box appears:

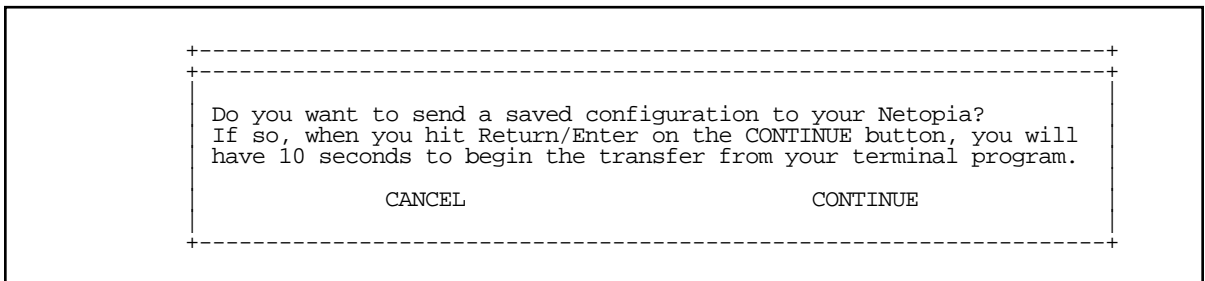

3. Select **CANCEL** to exit without downloading the file, or select **CONTINUE** to download the file.

If you choose CONTINUE, you will have ten seconds to use your terminal emulation software to initiate an XMODEM transfer of the configuration file. If you fail to initiate the transfer in that time, the dialog box will disappear and the terminal emulation software will inform you of the transfer's failure. You can then try again.

The system will reset at the end of a successful file transfer to put the new configuration into effect.

**Uploading configuration files**

A file containing a snapshot of the Netopia 4541/4542's current configuration can be uploaded from the router to disk. The file can then be downloaded by a different Netopia 4541/4542 to configure its parameters (see "Downloading configuration files," above). This is useful for configuring a number of routers with identical parameters or for creating configuration backup files.

Uploading a file can also be useful for troubleshooting purposes. The uploaded configuration file can be tested on a different Netopia 4541/4542 by Netopia or your network administrator.

The procedure below applies whether you are using the console or the WAN interface. To upload a configuration file:

1. Decide on a name for the file and a path for saving it.
2. Select **Receive Config from Netopia** and press Return. The following dialog box appears:

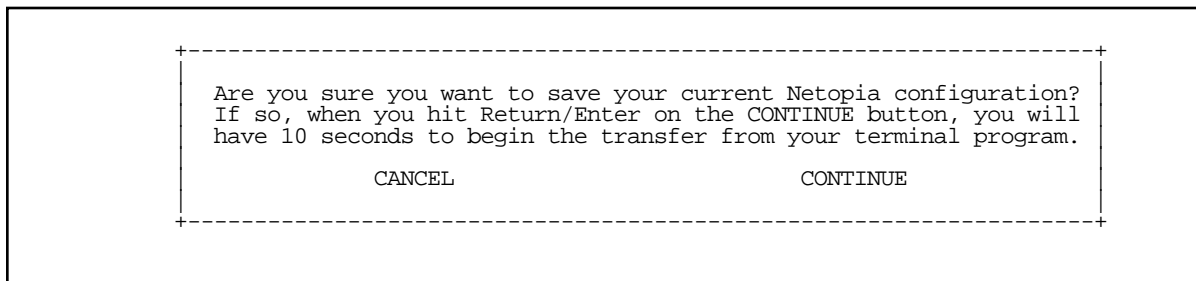

3. Select **CANCEL** to exit without uploading the file, or select **CONTINUE** to upload the file.

If you choose CONTINUE, you will have ten seconds to use your terminal emulation software to initiate an XMODEM transfer of the configuration file. If you fail to initiate the transfer in that time, the dialog box will disappear and the terminal emulation software will inform you of the transfer's failure. You can then try again.

---

## *Restarting the system*

You can restart the system by selecting the **Restart System** item in the Utilities & Diagnostics screen.

You must restart the system whenever you reconfigure the Netopia 4541/4542 and want the new parameter values to take effect. Under certain circumstances, restarting the system may also clear up system or network malfunctions. Some configuration processes automatically restart the system to apply the changes you have made.

# Appendix A

## Troubleshooting

This appendix is intended to help you troubleshoot problems you may encounter while setting up and using the Netopia 4541/4542. It also includes information on how to contact Netopia Technical Support.

Important information on these problems can be found in the event histories kept by the Netopia 4541/4542. These event histories can be accessed in the Statistics & Logs screen.

This section covers the following topics:

- [“Configuration problems” on page A-1](#)
- [“How to reset the router to factory defaults” on page A-3](#)
- [“Power outages” on page A-3](#)
- [“Technical support” on page A-4](#)

---

### Configuration problems

If you encounter problems during your initial configuration process, review the following suggestions before calling for technical support. There are four zones to consider when troubleshooting initial configuration:

1. The computer’s connection to the router
2. The router’s connection to the telecommunication line(s)
3. The telecommunication line’s connection to your ISP
4. The ISP’s connection to the Internet

If the connection from the computer to the router was not successful, verify that the following conditions are in effect:

- The Netopia 4541/4542 is turned on.
- An Ethernet cable connects your PC’s Ethernet card or built-in Ethernet port to the Netopia 4541/4542.
- Telnet is available on your PC or Macintosh. (On a PC, it must be specified in your system path. You can usually find the application as “c:\windows\telnet.exe”.)
- Your PC or Macintosh is properly configured for TCP/IP.
- Your PC or Macintosh has an IP address.
- Your PC or Macintosh has a subnet mask that matches or is compatible with the Netopia 4541/4542’s subnet mask.

**Note:** If you are attempting to modify the IP address or subnet mask from a previous, successful configuration attempt, you will need to clear the IP address or reset your Netopia 4541/4542 to the factory default before reinitiating the configuration process. For further information on resetting your Netopia 4541/4542 to factory default, see [“How to reset the router to factory defaults” on page A-3](#).

## *Console connection problems*

### *Can't see the configuration screens (nothing appears)*

- Make sure the cable connection from the Netopia 4541/4542's console port to the computer being used as a console is securely connected.
- Make sure the terminal emulation software is accessing the correct port on the computer that's being used as a console.
- Try pressing Ctrl-L or Return or the up or down arrow key several times to refresh the terminal screen.
- Make sure that flow control on serial connections is turned off.

### *Junk characters appear on the screen*

- Check that the terminal emulation software is configured correctly.
- Check the baud rate. The default values are 9600, N, 8, and 1.

### *Characters are missing from some of the configuration screens*

- Try changing the Netopia 4541/4542's default speed of 9600 bps and setting your terminal emulation software to match the new speed.

## *Network problems*

### *Problems communicating with remote IP hosts*

- Verify the accuracy of the default gateway's IP address (entered in the IP Setup or Easy Setup screen).
- Use the Netopia 4541/4542's Ping utility, in the Utilities & Diagnostics screen, and try to Ping local and remote hosts. See ["Ping" on page 13-2](#) for instructions on how to use the Ping utility. If you can successfully Ping hosts using their IP addresses but not their domain names (198.34.7.1 but not *garcia.netopia.com*, for example), verify that the DNS server's IP address is correct and that it is reachable from the Netopia 4541/4542 (use Ping).
- If you are using filters, check that your filter sets are not blocking the type of connections you are trying to make.

### *Local routing problems*

- Observe the Ethernet LEDs to see if data traffic flow appears to be normal.
- Check the WAN statistics and LAN statistics screens to see more specific information on data traffic flow and address serving. See ["Statistics & Logs" on page 12-4](#) for more information.

---

## How to reset the router to factory defaults

Lose your password? This section shows how to reset the router so that you can access the console screens once again. Keep in mind that all of your connection profiles and settings will need to be reconfigured.

If you don't have a password, the only way to get back into the Netopia 4541/4542 is the following:

1. Turn the router upside down.
2. Referring to the diagram below, find the paper clip-size Reset Switch slot.

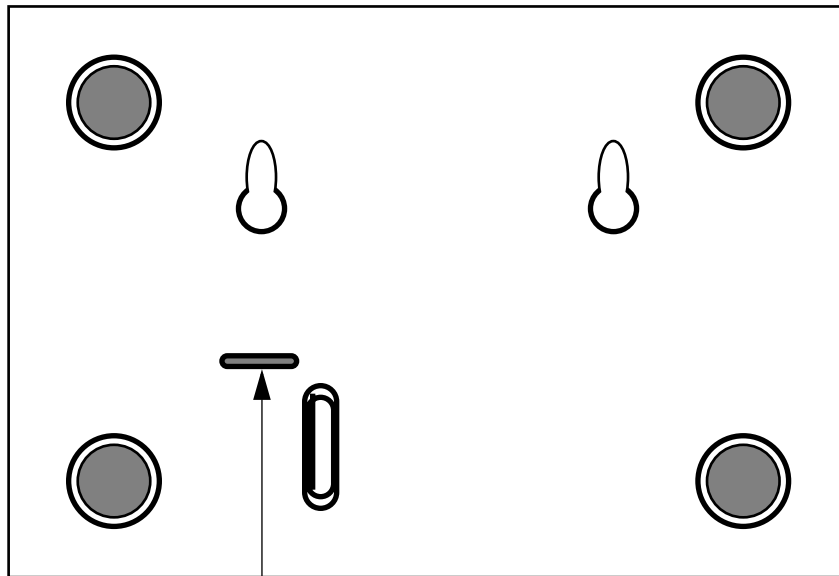

**Reset Switch Slot**

3. Carefully insert the larger end of a standard size paper clip until you contact the internal Reset Switch. (No need to unwind the paper clip.)
4. Press this switch.
5. This will reset the unit to factory defaults and you will now be able to reprogram the router.

---

## Power outages

If you suspect that power was restored after a power outage and the Netopia 4541/4542 is connected to a remote site, you may need to switch the Netopia 4541/4542 off and then back on again. After temporary power outages, a connection that still seems to be up may actually be disconnected. Rebooting the router should reestablish the connection.

## *Technical support*

Netopia, Inc. is committed to providing its customers with reliable products and documentation, backed by excellent technical support.

### *Before contacting Netopia*

Look in this guide for a solution to your problem. You may find a solution in this troubleshooting appendix or in other sections. Check the index for a reference to the topic of concern. If you cannot find a solution, complete the environment profile below before contacting Netopia Technical Support.

### *Environment profile*

- Locate the Netopia 4541/4542's model number, product serial number, and firmware version. The serial number is on the bottom of the router, along with the model number. The firmware version appears in the Netopia 4541/4542's Main Menu screen.

Model number:

Serial number:

Firmware version:

- What kind of local network(s) do you have, with how many devices?

Ethernet

TCP/IP

## *How to reach us*

We can help you with your problem more effectively if you have completed the environment profile in the previous section. If you contact us by telephone, please be ready to supply Netopia Technical Support with the information you used to configure the Netopia 4541/4542. Also, please be at the site of the problem and prepared to reproduce it and to try some troubleshooting steps.

When you are prepared, contact Netopia Technical Support by e-mail, telephone, fax, or post:

Internet: [techsports@netopia.com](mailto:techsports@netopia.com) (for technical support)

[info@netopia.com](mailto:info@netopia.com) (for general information)

Phone: 1 800-782-6449

Fax: 1 510-814-5023

Netopia, Inc.

Customer Service

2470 Mariner Square Loop

Alameda, California 94501

USA

Netopia Bulletin Board Service: 1 510-865-1321



*Online product information*

Product information can be found in the following:

Netopia World Wide Web server via <http://www.netopia.com>  
Internet via anonymous FTP to <ftp.netopia.com/pub>

*FAX-Back*

This service provides technical notes that answer the most commonly asked questions and offers solutions for many common problems encountered with Netopia products.

FAX-Back: 1 510-814-5040



## Appendix B

# Technical Specifications and Safety Information

---

### Description

**Dimensions:** 124.0 cm (w) x 20.0 cm (d) x 5.3 cm (h)  
9.4" (w) x 7.9" (d) x 2.1" (h)

**Communications interfaces:** The Netopia 4541/4542 ADSL Router has an RJ-48 jack for DSL connections; an RJ-45 10Base-T Ethernet port for your LAN connection; and a DB-9 Console port.

### Power requirements

- 12 VDC input
- 1.5 Amps

### Environment

**Operating temperature:** 0° to +40° C

**Storage temperature:** 0° to +70° C

**Relative storage humidity:** 20 to 80% non-condensing

### Software and protocols

**Software media:** Software preloaded on internal flash memory; field upgrades done via download to internal flash memory via XMODEM or TFTP

**Routing:** TCP/IP Internet Protocol Suite, RIP

**WAN support:** PPP, HDLC, ATM

**Security:** PAP, CHAP, MS-CHAP, IP firewalls, and UI password security

**SNMP network management:** SNMPv1, MIB-II (RFC 1213), Interface MIB (RFC 1229), Ethernet MIB (RFC 1643), Netopia 4541/4542 MIB

**Management/configuration methods:** serial console, remote modem console, Telnet, SNMP

**Diagnostics:** PING, event logging, routing table displays, traceroute, statistics counters

---

### Agency approvals

#### North America

Safety Approvals:

- United States – UL Standard for Information Technology Equipment, UL 60950, Third Edition, Dated

## ***B-2 User's Reference Guide***

December 1, 2000

- Canada – CSA: CAN/CSA-C22.2 No. 950-95

EMI:

- FCC Part 15 Class B

### ***International***

Safety Approvals:

- Low Voltage (European directive) 73/23/EEC
- EN60950 1992 (Europe)
- AS/NRZ 3260 (Australia)
- TS001(Australia)

EMI Compatibility:

- European Directive 89/336/EEC
- EN 300 368.2-1997

Telco:

- European Directive 1999/5/EC

## ***Regulatory notices***

### ***Warning***

This is a Class A product. In a domestic environment this product may cause radio interference, in which case the user may be required to take adequate measures. Adequate measures include increasing the physical distance between this product and other electrical devices.

**United States.** This equipment has been tested and found to comply with the limits for a Class A digital device, pursuant to Part 15 of the FCC Rules. These limits are designed to provide reasonable protection against harmful interference when the equipment is operated in a commercial environment. This equipment generates, uses, and can radiate radio frequency energy and, if not installed and used in accordance with the instruction manual, may cause harmful interference to radio communications. Operation of this equipment in a residential area is likely to cause harmful interference in which case the user will be required to correct the interference at his own expense. Operation is subject to the following two conditions: (1) this device may not cause harmful interference, and (2) this device must accept any interference received, including interference that may cause undesired operation.

**FCC Requirements, Part 68.** The Federal Communications Commission (FCC) has established Rules which permit this device to be directly connected to the telephone network. Standardized jacks are used for these connections. This equipment should not be used on party lines or coin phones.

If this device is malfunctioning, it may also be causing harm to the telephone network; this device should be disconnected until the source of the problem can be determined and until repair has been made. If this is not done, the telephone company may temporarily disconnect service.

The telephone company may make changes in its technical operations and procedures; if such changes affect the compatibility or use of this device, the telephone company is required to give adequate notice of the changes. You will be advised of your right to file a complaint with the FCC.

If the telephone company requests information on what equipment is connected to their lines, inform them of:

- a) The telephone number to which this unit is connected.
- b) The ringer equivalence number
- c) The USOC jack required. (RJ11C)
- d) The FCC Registration Number. (14 digits provided by FCC)

Items (b) and (d) are indicated on the label. The Ringer Equivalence Number (REN) is used to determine how many devices can be connected to your telephone line. In most areas, the sum of the REN's of all devices on any one line should not exceed five (5.0). If too many devices are attached, they may not ring properly.

**Service Requirements.** In the event of equipment malfunction, all repairs should be performed by our Company or an authorized agent. Under FCC rules, no customer is authorized to repair this equipment. This restriction applies regardless of whether the equipment is in or out of warranty. It is the responsibility of users requiring service to report the need for service to our Company or to one of our authorized agents. Service can be obtained at Netopia, Inc., 2470 Mariner Square Loop, Alameda, California, 94501.

### *Important*

This product was tested for FCC compliance under conditions that included the use of shielded cables and connectors between system components. Changes or modifications to this product not authorized by the manufacturer could void your authority to operate the equipment.

**Canada.** This digital apparatus does not exceed the Class A limits for radio noise emission from digital apparatus set out in the Radio Interference Regulations of the Canadian Department of Communications.

Le présent appareil numérique n'émet pas de bruits radioélectriques dépassant les limites applicables aux appareils numériques de la classe A prescrites dans le Règlement sur le brouillage radioélectrique édicté par le ministère des Communications du Canada.

### *Declaration for Canadian users*

The Canadian Industry Canada label identifies certified equipment. This certification means that the equipment meets certain telecommunications network protective, operation and safety requirements. The Department does not guarantee the equipment will operate to the user's satisfaction.

Before installing this equipment, users should ensure that it is permissible to be connected to the facilities of the local telecommunications company. The equipment must also be installed using an acceptable method of connection. In some cases, the company's inside wiring associated with a single line individual service may be extended by means of a certified connector assembly (telephone extension cord.) The customer should be aware that compliance with the above conditions may not prevent degradation of service in some situations.

Repairs to the certified equipment should be made by an authorized Canadian maintenance facility designated by the supplier. Any repairs or alterations made by the user to this equipment, or equipment malfunctions, may give the telecommunications company cause to request the user to disconnect the equipment.

Users should ensure for their own protection that the electrical ground connections of the power utility, telephone lines and internal metallic water pipe system, if present, are connected together. This precaution may be particularly important in rural areas.

## ***B-4 User's Reference Guide***

### ***Caution***

Users should not attempt to make such connections themselves, but should contact the appropriate electric inspection authority, or electrician, as appropriate.

The Load Number (LN) assigned to each terminal device denotes the percentage of the total load to be connected to a telephone loop which is used by the device, to prevent overloading. The termination on a loop may consist of any combination of devices subject only to the requirement that the total of the Load Numbers of all the devices does not exceed 100.

## ***Important safety instructions***

### ***Australian Safety Information***

The following safety information is provided in conformance with Australian safety requirements:

**CAUTION: DO NOT USE BEFORE READING THE INSTRUCTIONS:** Do not connect the Ethernet port to a carrier or carriage service provider's telecommunications network or facility unless: a) you have the written consent of the network or facility manager, or b) the connection is in accordance with a connection permit or connection rules.

Connection of the Ethernet port may cause a hazard or damage to the telecommunication network or facility, or persons, with consequential liability for substantial compensation.

### ***Caution***

- Depending on the power supply provided with the product, either the direct plug-in power supply blades, power supply cord plug or the appliance coupler serves as the mains power disconnect. It is important that the direct plug-in power supply, socket-outlet or appliance coupler be located so it is readily accessible.
- (North America Only) For use only with a CSA Certified or UL Listed Limited Power Source or Class 2 power supply, rated 12Vdc, 1.5A.
- (Europe Only): For use only with a GS approved Limited Power Source, rated 12Vdc, 1.5A.

### ***Telecommunication installation cautions***

When using your telephone equipment, basic safety precautions should always be followed to reduce the risk of fire, electric shock and injury to persons, including the following:

- Do not use this product near water, for example, near a bathtub, wash bowl, kitchen sink or laundry tub, in a wet basement or near a swimming pool.
- Avoid using a telephone (other than a cordless type) during an electrical storm. There may be a remote risk of electrical shock from lightning.
- Do not use the telephone to report a gas leak in the vicinity of the leak. Never install telephone wiring during a lightning storm.

### ***Battery***

The Netopia 4541/4542's lithium battery is designed to last for the life of the product. The battery is not user-serviceable.

### ***Caution!***

Danger of explosion if battery is incorrectly replaced.

Replace only with the same or equivalent type recommended by the manufacturer. Dispose of used batteries according to the manufacturer's instructions.





## ***Limited Warranty and Limitation of Remedies-Revised January 2002***

Netopia warrants to you, the end user, that the Netopia™ Router (the "Product") will be free from defects in materials and workmanship under normal use for a period of two (2) years from date of purchase. Netopia's entire liability and your sole remedy under this warranty during the warranty period is that Netopia shall, at its sole option, either repair or replace the Product.

In order to make a claim under this warranty you must comply with the following procedure:

1. Contact Netopia Customer Service within the warranty period to obtain a Return Materials Authorization ("RMA") number.
2. Return the defective Product and proof of purchase, shipping prepaid, to Netopia with the RMA number prominently displayed on the outside of the package.

If you are located outside of the United States or Canada, please contact your dealer in order to arrange for warranty service.

THE ABOVE WARRANTIES ARE MADE BY NETOPIA ALONE, AND THEY ARE THE ONLY WARRANTIES MADE BY ANYONE REGARDING THE ENCLOSED PRODUCT. NETOPIA AND ITS LICENSOR(S) MAKE NO OTHER WARRANTIES, EXPRESS OR IMPLIED, INCLUDING WITHOUT LIMITATION THE IMPLIED WARRANTIES OF MERCHANTABILITY AND FITNESS FOR A PARTICULAR PURPOSE, REGARDING THE ENCLOSED PRODUCT. EXCEPT AS OTHERWISE EXPRESSLY PROVIDED ABOVE, NETOPIA AND ITS LICENSOR(S) DO NOT WARRANT, GUARANTEE OR MAKE ANY REPRESENTATION REGARDING THE USE OR THE RESULTS OF THE USE OF THE PRODUCT IN TERMS OF ITS CORRECTNESS, ACCURACY, RELIABILITY, CURRENTNESS, OR OTHERWISE. THE ENTIRE RISK AS TO THE RESULTS AND PERFORMANCE OF THE PRODUCT IS ASSUMED BY YOU. THE EXCLUSION OF IMPLIED WARRANTIES IS NOT PERMITTED BY SOME STATES OR JURISDICTIONS, SO THE ABOVE EXCLUSION MAY NOT APPLY TO YOU. IN THAT CASE, ANY IMPLIED WARRANTIES ARE LIMITED IN DURATION TO NINETY (90) DAYS FROM THE DATE OF DELIVERY OF THE PRODUCT. THERE MAY BE OTHER RIGHTS THAT YOU MAY HAVE WHICH VARY FROM JURISDICTION TO JURISDICTION.

REGARDLESS OF WHETHER OR NOT ANY REMEDY SET FORTH HEREIN FAILS OF ITS ESSENTIAL PURPOSE, IN NO EVENT WILL NETOPIA, ITS LICENSOR(S) AND THE DIRECTORS, OFFICERS, EMPLOYEES OR AGENTS OF ANY OF THEM BE LIABLE TO YOU FOR ANY CONSEQUENTIAL, INCIDENTAL OR INDIRECT DAMAGES (INCLUDING DAMAGES FOR LOSS OF BUSINESS PROFITS, BUSINESS INTERRUPTION, LOSS OF BUSINESS INFORMATION, AND THE LIKE) ARISING OUT THE USE OR INABILITY TO USE THE PRODUCT EVEN IF NETOPIA OR ITS LICENSOR(S) HAVE BEEN ADVISED OF THE POSSIBILITY OF SUCH DAMAGES. NETOPIA AND ITS LICENSOR(S) LIABILITY TO YOU FOR ACTUAL DAMAGES FROM ANY CAUSE WHATSOEVER, AND REGARDLESS OF THE FORM OF THE ACTION (WHETHER IN CONTRACT, TORT [INCLUDING NEGLIGENCE], PRODUCT LIABILITY OR OTHERWISE), WILL BE LIMITED TO \$50. BECAUSE SOME STATES OR JURISDICTIONS DO NOT ALLOW THE EXCLUSION OR LIMITATION OF LIABILITY FOR CONSEQUENTIAL OR INCIDENTAL DAMAGES, THE ABOVE LIMITATIONS MAY NOT APPLY TO YOU. v.102