

Enterasys Matrix[®]

DFE-Platinum Series

Hardware Installation Guide

Module 2G4082-25



Electrical Hazard: Only qualified personnel should perform installation procedures.

Riesgo Electrico: Solamente personal calificado debe realizar procedimientos de instalacion.

Elektrischer Gefahrenhinweis: Installationen sollten nur durch ausgebildetes und qualifiziertes Personal vorgenommen werden.

Notice

Enterasys Networks reserves the right to make changes in specifications and other information contained in this document and its web site without prior notice. The reader should in all cases consult Enterasys Networks to determine whether any such changes have been made.

The hardware, firmware, or software described in this document is subject to change without notice.

IN NO EVENT SHALL ENTERASYS NETWORKS BE LIABLE FOR ANY INCIDENTAL, INDIRECT, SPECIAL, OR CONSEQUENTIAL DAMAGES WHATSOEVER (INCLUDING BUT NOT LIMITED TO LOST PROFITS) ARISING OUT OF OR RELATED TO THIS DOCUMENT, WEB SITE, OR THE INFORMATION CONTAINED IN THEM, EVEN IF ENTERASYS NETWORKS HAS BEEN ADVISED OF, KNEW OF, OR SHOULD HAVE KNOWN OF, THE POSSIBILITY OF SUCH DAMAGES.

Enterasys Networks, Inc.
50 Minuteman Road
Andover, MA 01810

© 2008 Enterasys Networks, Inc. All rights reserved.

Part Number: 9034310-01 July 2008

ENTERASYS, ENTERASYS NETWORKS, ENTERASYS MATRIX, ENTERASYS NETSIGHT, LANVIEW, WEBVIEW, and any logos associated therewith, are trademarks or registered trademarks of Enterasys Networks, Inc., in the United States and other countries. For a complete list of Enterasys trademarks, see <http://www.enterasys.com/company/trademarks.aspx>.

All other product names mentioned in this manual may be trademarks or registered trademarks of their respective companies.

Documentation URL: <http://www.enterasys.com/support/manuals>

Documentacion URL: <http://www.enterasys.com/support/manuals>

Dokumentation im Internet: <http://www.enterasys.com/support/manuals>

Regulatory Compliance Information

Federal Communications Commission (FCC) Notice

This device complies with Part 15 of the FCC rules. Operation is subject to the following two conditions: (1) this device may not cause harmful interference, and (2) this device must accept any interference received, including interference that may cause undesired operation.

NOTE: This equipment has been tested and found to comply with the limits for a class A digital device, pursuant to Part 15 of the FCC rules. These limits are designed to provide reasonable protection against harmful interference when the equipment is operated in a commercial environment. This equipment uses, generates, and can radiate radio frequency energy and if not installed in accordance with the operator's manual, may cause harmful interference to radio communications. Operation of this equipment in a residential area is likely to cause interference in which case the user will be required to correct the interference at his own expense.

WARNING: Changes or modifications made to this device which are not expressly approved by the party responsible for compliance could void the user's authority to operate the equipment.

Industry Canada Notice

This digital apparatus does not exceed the class A limits for radio noise emissions from digital apparatus set out in the Radio Interference Regulations of the Canadian Department of Communications.

Le présent appareil numérique n'émet pas de bruits radioélectriques dépassant les limites applicables aux appareils numériques de la class A prescrites dans le Règlement sur le brouillage radioélectrique édicté par le ministère des Communications du Canada.

Class A ITE Notice

WARNING: This is a Class A product. In a domestic environment this product may cause radio interference in which case the user may be required to take adequate measures.

Clase A. Aviso de ITE

ADVERTENCIA: Este es un producto de Clase A. En un ambiente doméstico este producto puede causar interferencia de radio en cuyo caso puede ser requerido tomar medidas adecuadas.

Klasse A ITE Anmerkung

WARNHINWEIS: Dieses Produkt zählt zur Klasse A (Industriebereich). In Wohnbereichen kann es hierdurch zu Funkstörungen kommen, daher sollten angemessene Vorkehrungen zum Schutz getroffen werden.

Product Safety

This product complies with the following: UL 60950, CSA C22.2 No. 60950, 2006/95/EC, EN 60950, IEC 60950, EN 60825, 21 CFR 1040.10.

Seguridad del Producto

El producto de Enterasys cumple con lo siguiente: UL 60950, CSA C22.2 No. 60950, 2006/95/EC, EN 60950, IEC 60950, EN 60825, 21 CFR 1040.10.

Produktsicherheit

Dieses Produkt entspricht den folgenden Richtlinien: UL 60950, CSA C22.2 No. 60950, 2006/95/EC, EN 60950, IEC 60950, EN 60825, 21 CFR 1040.10.

Electromagnetic Compatibility (EMC)

This product complies with the following: 47 CFR Parts 2 and 15, CSA C108.8, 2004/108/EC, EN 55022, EN 61000-3-2, EN 61000-3-3, EN 55024, AS/NZS CISPR 22, VCCI V-3.

Compatibilidad Electromagnética (EMC)

Este producto de Enterasys cumple con lo siguiente: 47 CFR Partes 2 y 15, CSA C108.8, 2004/108/EC, EN 55022, EN 55024, EN 61000-3-2, EN 61000-3-3, AS/NZS CISPR 22, VCCI V-3.

Elektro- magnetische Kompatibilität (EMC)

Dieses Produkt entspricht den folgenden Richtlinien: 47 CFR Parts 2 and 15, CSA C108.8, 2004/108/EC, EN 55022, EN 61000-3-2, EN 61000-3-3, EN 55024, AS/NZS CISPR 22, VCCI V-3.

Hazardous Substances

This product complies with the requirements of European Directive, 2002/95/EC, Restriction of Hazardous Substances (RoHS) in Electrical and Electronic Equipment.

European Waste Electrical and Electronic Equipment (WEEE) Notice

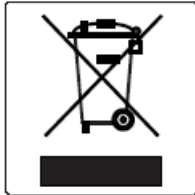

In accordance with Directive 2002/96/EC of the European Parliament on waste electrical and electronic equipment (WEEE):

1. The symbol above indicates that separate collection of electrical and electronic equipment is required and that this product was placed on the European market after August 13, 2005, the date of enforcement for Directive 2002/96/EC.
2. When this product has reached the end of its serviceable life, it cannot be disposed of as unsorted municipal waste. It must be collected and treated separately.
3. It has been determined by the European Parliament that there are potential negative effects on the environment and human health as a result of the presence of hazardous substances in electrical and electronic equipment.
4. It is the users' responsibility to utilize the available collection system to ensure WEEE is properly treated.

For information about the available collection system, please go to www.enterasys.com/support/ or contact Enterasys Customer Support at 353 61 705586 (Ireland).

产品说明书附件

Supplement to Product Instructions

部件名称 (Parts)	有毒有害物质或元素 (Hazardous Substance)					
	铅 (Pb)	汞 (Hg)	镉 (Cd)	六价铬 (Cr ⁶⁺)	多溴联苯 (PBB)	多溴二苯醚 (PBDE)
金属部件 (Metal Parts)	×	○	○	×	○	○
电路模块 (Circuit Modules)	×	○	○	×	○	○
电缆及电缆组件 (Cables & Cable Assemblies)	×	○	○	×	○	○
塑料和聚合物部件 (Plastic and Polymeric parts)	○	○	○	○	○	×
电路开关 (Circuit Breakers)	○	○	×	×	○	○

○： 表示该有毒有害物质在该部件所有均质材料中的含量均在 SJ/T 11363-2006 标准规定的限量要求以下。
Indicates that the concentration of the hazardous substance in all homogeneous materials in the parts is below the relevant threshold of the SJ/T 11363-2006 standard.

×： 表示该有毒有害物质至少在该部件的某一均质材料中的含量超出SJ/T 11363-2006 标准规定的限量要求。
Indicates that the concentration of the hazardous substance of at least one of all homogeneous materials in the parts is above the relevant threshold of the SJ/T 11363-2006 standard.

对销售之日的所售产品, 本表显示, 凯创供应链的电子产品信息产品可能包含这些物质。注意: 在所售产品中可能会也可能不会含有所有所列的部件。
This table shows where these substances may be found in the supply chain of Enterasys' electronic information products, as of the date of sale of the enclosed product. Note that some of the component types listed above may or may not be a part of the enclosed product.

除非另外特别的标注, 此标志为针对所涉及产品的环保使用期标志。某些零部件会有一个不同的环保使用期(例如, 电池单元模块)贴在其产品上。
此环保使用期限只适用于产品是在产品手册中所规定的条件下工作。
The Environmentally Friendly Use Period (EFUP) for all enclosed products and their parts are per the symbol shown here, unless otherwise marked. Certain parts may have a different EFUP (for example, battery modules) and so are marked to reflect such. The Environmentally Friendly Use Period is valid only when the product is operated under the conditions defined in the product manual.



VCCI Notice

This is a class A product based on the standard of the Voluntary Control Council for Interference by Information Technology Equipment (VCCI). If this equipment is used in a domestic environment, radio disturbance may arise. When such trouble occurs, the user may be required to take corrective actions.

この装置は、情報処理装置等電波障害自主規制協議会（VCCI）の基準に基づくクラスA情報技術装置です。この装置を家庭環境で使用すると電波妨害を引き起こすことがあります。この場合には使用者が適切な対策を講ずるよう要求されることがあります。

BSMI EMC Statement — Taiwan

This is a class A product. In a domestic environment this product may cause radio interference in which case the user may be required to take adequate measures.

警告使用者：

這是甲類的資訊產品，在居住的環境中使用時，可能會造成射頻干擾，在這種情況下，使用者會被要求採取某些適當的對策。

Safety Information Class 1 Laser Transceivers

**The single mode interface modules use Class 1 laser transceivers.
Read the following safety information before installing or operating these modules.**

The Class 1 laser transceivers use an optical feedback loop to maintain Class 1 operation limits. This control loop eliminates the need for maintenance checks or adjustments. The output is factory set, and does not allow any user adjustment. Class 1 Laser transceivers comply with the following safety standards:

- 21 CFR 1040.10 and 1040.11 U.S. Department of Health and Human Services (FDA).
- IEC Publication 825 (International Electrotechnical Commission).
- CENELEC EN 60825 (European Committee for Electrotechnical Standardization).

When operating within their performance limitations, laser transceiver output meets the Class 1 accessible emission limit of all three standards. Class 1 levels of laser radiation are not considered hazardous.

When the connector is in place, all laser radiation remains within the fiber. The maximum amount of radiant power exiting the fiber (under normal conditions) is -12.6 dBm or 55×10^{-6} watts.

Removing the optical connector from the transceiver allows laser radiation to emit directly from the optical port. The maximum radiance from the optical port (under worst case conditions) is 0.8 W cm^{-2} or $8 \times 10^3 \text{ W m}^{-2} \text{ sr}^{-1}$.

Do not use optical instruments to view the laser output. The use of optical instruments to view laser output increases eye hazard. When viewing the output optical port, power must be removed from the network adapter.

Declaration of Conformity

Application of Council Directive(s): 2004/108/EC
2006/95/EC

Manufacturer's Name: Enterasys Networks, Inc.

Manufacturer's Address: 50 Minuteman Road
Andover, MA 01810
USA

European Representative Address: Enterasys Networks, Ltd.
Nexus House, Newbury Business Park
London Road, Newbury
Berkshire RG14 2PZ, England

Conformance to Directive(s)/Product Standards: EC Directive 2004/108/EC
EN 55022
EN 61000-3-2
EN 61000-3-3
EN 55024
EC Directive 2006/95/EC
EN 60950
EN 60825

Equipment Type/Environment: Networking Equipment, for use in a Commercial
or Light Industrial Environment.

Enterasys Networks, Inc. declares that the equipment packaged with this notice conforms to the above directives.

ENTERASYS NETWORKS, INC. FIRMWARE LICENSE AGREEMENT

BEFORE OPENING OR UTILIZING THE ENCLOSED PRODUCT, CAREFULLY READ THIS LICENSE AGREEMENT.

This document is an agreement ("Agreement") between the end user ("You") and Enterasys Networks, Inc., on behalf of itself and its Affiliates (as hereinafter defined) ("Enterasys") that sets forth Your rights and obligations with respect to the Enterasys software program/firmware (including any accompanying documentation, hardware or media) ("Program") in the package and prevails over any additional, conflicting or inconsistent terms and conditions appearing on any purchase order or other document submitted by You. "Affiliate" means any person, partnership, corporation, limited liability company, other form of enterprise that directly or indirectly through one or more intermediaries, controls, or is controlled by, or is under common control with the party specified. This Agreement constitutes the entire understanding between the parties, with respect to the subject matter of this Agreement. The Program may be contained in firmware, chips or other media.

BY INSTALLING OR OTHERWISE USING THE PROGRAM, YOU REPRESENT THAT YOU ARE AUTHORIZED TO ACCEPT THESE TERMS ON BEHALF OF THE END USER (IF THE END USER IS AN ENTITY ON WHOSE BEHALF YOU ARE AUTHORIZED TO ACT, "YOU" AND "YOUR" SHALL BE DEEMED TO REFER TO SUCH ENTITY) AND THAT YOU AGREE THAT YOU ARE BOUND BY THE TERMS OF THIS AGREEMENT, WHICH INCLUDES, AMONG OTHER PROVISIONS, THE LICENSE, THE DISCLAIMER OF WARRANTY AND THE LIMITATION OF LIABILITY. IF YOU DO NOT AGREE TO THE TERMS OF THIS AGREEMENT OR ARE NOT AUTHORIZED TO ENTER INTO THIS AGREEMENT, ENTERASYS IS UNWILLING TO LICENSE THE PROGRAM TO YOU AND YOU AGREE TO RETURN THE UNOPENED PRODUCT TO ENTERASYS OR YOUR DEALER, IF ANY, WITHIN TEN (10) DAYS FOLLOWING THE DATE OF RECEIPT FOR A FULL REFUND.

IF YOU HAVE ANY QUESTIONS ABOUT THIS AGREEMENT, CONTACT ENTERASYS NETWORKS, LEGAL DEPARTMENT AT (978) 684-1000.

You and Enterasys agree as follows:

1. **LICENSE.** You have the non-exclusive and non-transferable right to use only the one (1) copy of the Program provided in this package subject to the terms and conditions of this Agreement.
2. **RESTRICTIONS.** Except as otherwise authorized in writing by Enterasys, You may not, nor may You permit any third party to:
 - (a) Reverse engineer, decompile, disassemble or modify the Program, in whole or in part, including for reasons of error correction or interoperability, except to the extent expressly permitted by applicable law and to the extent the parties

shall not be permitted by that applicable law, such rights are expressly excluded. Information necessary to achieve interoperability or correct errors is available from Enterasys upon request and upon payment of Enterasys' applicable fee.

- (b) Incorporate the Program in whole or in part, in any other product or create derivative works based on the Program, in whole or in part.
- (c) Publish, disclose, copy reproduce or transmit the Program, in whole or in part.
- (d) Assign, sell, license, sublicense, rent, lease, encumber by way of security interest, pledge or otherwise transfer the Program, in whole or in part.
- (e) Remove any copyright, trademark, proprietary rights, disclaimer or warning notice included on or embedded in any part of the Program.

3. **APPLICABLE LAW.** This Agreement shall be interpreted and governed under the laws and in the state and federal courts of the Commonwealth of Massachusetts without regard to its conflicts of laws provisions. You accept the personal jurisdiction and venue of the Commonwealth of Massachusetts courts. None of the 1980 United Nations Convention on the Limitation Period in the International Sale of Goods, and the Uniform Computer Information Transactions Act shall apply to this Agreement.

4. **EXPORT RESTRICTIONS.** You understand that Enterasys and its Affiliates are subject to regulation by agencies of the U.S. Government, including the U.S. Department of Commerce, which prohibit export or diversion of certain technical products to certain countries, unless a license to export the product is obtained from the U.S. Government or an exception from obtaining such license may be relied upon by the exporting party.

If the Program is exported from the United States pursuant to the License Exception CIV under the U.S. Export Administration Regulations, You agree that You are a civil end user of the Program and agree that You will use the Program for civil end uses only and not for military purposes.

If the Program is exported from the United States pursuant to the License Exception TSR under the U.S. Export Administration Regulations, in addition to the restriction on transfer set forth in Section 1 or 2 of this Agreement, You agree not to (i) reexport or release the Program, the source code for the Program or technology to a national of a country in Country Groups D:1 or E:2 (Albania, Armenia, Azerbaijan, Belarus, Cambodia, Cuba, Georgia, Iraq, Kazakhstan, Laos, Libya, Macau, Moldova, Mongolia, North Korea, the People's Republic of China, Russia, Tajikistan, Turkmenistan, Ukraine, Uzbekistan, Vietnam, or such other countries as may be designated by the United States Government), (ii) export to Country Groups D:1 or E:2 (as defined herein) the direct product of the Program or the technology, if such foreign produced direct product is subject to national security controls as identified on the U.S. Commerce Control List, or (iii) if the direct product of the technology is a complete plant or any major component of a plant, export to Country Groups D:1 or E:2 the direct product of the plant or a major component thereof, if such foreign produced direct product is subject to national security controls as identified on the U.S. Commerce Control List or is subject to State Department controls under the U.S. Munitions List.

5. **UNITED STATES GOVERNMENT RESTRICTED RIGHTS.** The enclosed Program (i) was developed solely at private expense; (ii) contains "restricted computer software" submitted with restricted rights in accordance with section 52.227-19 (a) through (d) of the Commercial Computer Software-Restricted Rights Clause and its successors, and (iii) in all respects is proprietary data belonging to Enterasys and/or its suppliers. For Department of Defense units, the Program is considered commercial computer software in accordance with DFARS section 227.7202-3 and its successors, and use, duplication, or disclosure by the U.S. Government is subject to restrictions set forth herein.

6. **DISCLAIMER OF WARRANTY.** EXCEPT FOR THOSE WARRANTIES EXPRESSLY PROVIDED TO YOU IN WRITING BY ENTERASYS, ENTERASYS DISCLAIMS ALL WARRANTIES, EITHER EXPRESS OR IMPLIED, INCLUDING BUT NOT LIMITED TO IMPLIED WARRANTIES OF MERCHANTABILITY, SATISFACTORY QUALITY, FITNESS FOR A PARTICULAR PURPOSE, TITLE AND NON-INFRINGEMENT WITH RESPECT TO THE PROGRAM. IF IMPLIED WARRANTIES MAY NOT BE DISCLAIMED BY APPLICABLE LAW, THEN ANY IMPLIED WARRANTIES ARE LIMITED IN DURATION TO THIRTY (30) DAYS AFTER DELIVERY OF THE PROGRAM TO YOU.

7. **LIMITATION OF LIABILITY.** IN NO EVENT SHALL ENTERASYS OR ITS SUPPLIERS BE LIABLE FOR ANY DAMAGES WHATSOEVER (INCLUDING, WITHOUT LIMITATION, DAMAGES FOR LOSS OF BUSINESS, PROFITS, BUSINESS INTERRUPTION, LOSS OF BUSINESS INFORMATION, SPECIAL, INCIDENTAL, CONSEQUENTIAL, OR RELIANCE DAMAGES, OR OTHER LOSS) ARISING OUT OF THE USE OR INABILITY TO USE THE PROGRAM, EVEN IF ENTERASYS HAS BEEN ADVISED OF THE POSSIBILITY OF SUCH DAMAGES. THIS FOREGOING LIMITATION SHALL APPLY REGARDLESS OF THE CAUSE OF ACTION UNDER WHICH DAMAGES ARE SOUGHT.

THE CUMULATIVE LIABILITY OF ENTERASYS TO YOU FOR ALL CLAIMS RELATING TO THE PROGRAM, IN CONTRACT, TORT OR OTHERWISE, SHALL NOT EXCEED THE TOTAL AMOUNT OF FEES PAID TO ENTERASYS BY YOU FOR THE RIGHTS GRANTED HEREIN.

8. **AUDIT RIGHTS.** You hereby acknowledge that the intellectual property rights associated with the Program are of critical value to Enterasys, and, accordingly, You hereby agree to maintain complete books, records and accounts showing (i) license fees due and paid, and (ii) the use, copying and deployment of the Program. You also grant to Enterasys and its authorized representatives, upon reasonable notice, the right to audit and examine during Your normal business hours, Your books, records, accounts and hardware devices upon which the Program may be deployed to verify compliance with this Agreement, including the verification of the license fees due and paid Enterasys and the use, copying and deployment of the Program. Enterasys' right of examination shall be exercised reasonably, in good faith and in a manner calculated to not unreasonably interfere with Your business. In the event such audit discovers non-compliance with this Agreement, including copies of the Program made, used or deployed in breach of this Agreement, You shall promptly pay to Enterasys the appropriate license fees. Enterasys reserves the right, to be exercised in its sole discretion and without prior notice, to terminate this license, effective immediately, for failure to comply with this Agreement. Upon any such termination, You shall immediately cease all use of the Program and shall return to Enterasys the Program and all copies of the Program.

9. **OWNERSHIP.** This is a license agreement and not an agreement for sale. You acknowledge and agree that the Program constitutes trade secrets and/or copyrighted material of Enterasys and/or its suppliers. You agree to implement reasonable security measures to protect such trade secrets and copyrighted material. All right, title and interest in and to the Program shall remain with Enterasys and/or its suppliers. All rights not specifically granted to You shall be reserved to Enterasys.

10. **ENFORCEMENT.** You acknowledge and agree that any breach of Sections 2, 4, or 9 of this Agreement by You may cause Enterasys irreparable damage for which recovery of money damages would be inadequate, and that Enterasys may be entitled to seek timely injunctive relief to protect Enterasys' rights under this Agreement in addition to any and all remedies available at law.

11. **ASSIGNMENT.** You may not assign, transfer or sublicense this Agreement or any of Your rights or obligations under this Agreement, except that You may assign this Agreement to any person or entity which acquires substantially all of Your stock assets. Enterasys may assign this Agreement in its sole discretion. This Agreement shall be binding upon and inure to the benefit of the parties, their legal representatives, permitted transferees, successors and assigns as permitted by this Agreement. Any attempted assignment, transfer or sublicense in violation of the terms of this Agreement shall be void and a breach of this Agreement.

12. **WAIVER.** A waiver by Enterasys of a breach of any of the terms and conditions of this Agreement must be in writing and will not be construed as a waiver of any subsequent breach of such term or condition. Enterasys' failure to enforce a term upon Your breach of such term shall not be construed as a waiver of Your breach or prevent enforcement on any other occasion.

13. **SEVERABILITY.** In the event any provision of this Agreement is found to be invalid, illegal or unenforceable, the validity, legality and enforceability of any of the remaining provisions shall not in any way be affected or impaired thereby, and that provision shall be reformed, construed and enforced to the maximum extent permissible. Any such invalidity, illegality, or unenforceability in any jurisdiction shall not invalidate or render illegal or unenforceable such provision in any other jurisdiction.

14. **TERMINATION.** Enterasys may terminate this Agreement immediately upon Your breach of any of the terms and conditions of this Agreement. Upon any such termination, You shall immediately cease all use of the Program and shall return to Enterasys the Program and all copies of the Program.

Contents

About This Guide

Who Should Use This Guide	xi
How to Use This Guide	xii
Related Documents	xii
Conventions Used in This Guide	xiii
Getting Help	xiii

Chapter 1: Introduction

Overview of DFE Series Capabilities	1-1
DFE-Platinum Module	1-2
2G4082-25	1-2
Network Expansion Module (NEM) Option	1-4
Connectivity	1-4
Management	1-4
Switch Configuration Using WebView	1-4
Switch Configuration Using CLI Commands	1-4
Secure Networks Policy Support	1-5
Standards Compatibility	1-5
LANVIEW Diagnostic LEDs	1-5

Chapter 2: Network Requirements

Link Aggregation	2-1
10BASE-T Network	2-2
100BASE-TX Network	2-2
1000BASE-T Network	2-2
1000BASE-SX/LX/ELX Network	2-2

Chapter 3: Installation

Unpacking the DFE-Platinum Module	3-2
Installing Optional Network Expansion Modules	3-2
Installing Module into Matrix E7 or N7 Chassis	3-2
Preparation	3-3
Installation	3-3
Installing Module into Matrix N1, N3, or N5 Chassis	3-5
Connecting to the Network	3-6
Connecting UTP Cables	3-6
Connecting to COM Port for Local Management	3-10
What Is Needed	3-10
Connecting to an IBM PC or Compatible Device	3-10
Connecting to a VT Series Terminal	3-11
Connecting to a Modem	3-12
Adapter Wiring and Signal Assignments	3-13
Completing the Installation of a New System	3-15
First-Time Log-In Using a Console Port Connection	3-15
Logging in with an Administratively-Configured User Account	3-16

Chapter 4: Troubleshooting

Using LANVIEW	4-1
Troubleshooting Checklist	4-4
Overview of DFE-Platinum Module Shutdown Procedure	4-5

Recommended Shutdown Procedure	4-6
Last Resort Shutdown Procedure	4-6

Appendix A: Specifications

DFE-Platinum Module Specifications	A-1
COM Port Pinout Assignments	A-2
Regulatory Compliance	A-2

Appendix B: Mode Switch Bank Settings and Optional Installations

Required Tools	B-1
Setting the Mode Switches	B-1
Memory Locations and Replacement Procedures	B-2
Location of Memory Modules	B-3
Flash DIMM Replacement Procedure	B-3
DRAM SIMM Replacement Procedure	B-6

Index

Figures

1-1	DFE-Platinum 2G4082-25 Module	1-3
3-1	Installing Module into Matrix E7 or Matrix N7 Chassis (E7 shown)	3-4
3-2	Installing Module into N3, N1, or N5 Chassis (N3 shown).....	3-6
3-3	Connecting a Twisted Pair Segment to the DFE-Platinum Module	3-7
3-4	Four-Wire Crossover Cable RJ45 Pinouts, Connections Between Hub Devices	3-8
3-5	Four-Wire Straight-Through Cable RJ45 Pinouts, Connections Between Switches and End User Devices.....	3-8
3-6	Eight-Wire Crossover Cable RJ45 Pinouts, Connections Between Hub Devices	3-9
3-7	Eight-Wire Straight-Through Cable RJ45 Pinouts, Connections	3-9
3-8	Connecting an IBM PC or Compatible.....	3-11
3-9	Connecting a VT Series Terminal.....	3-12
3-10	Connecting to a Modem	3-13
3-11	Matrix DFE Startup Screen Example (N7 Chassis).....	3-16
4-1	LANVIEW LEDs.....	4-2
4-2	OFFLINE/RESET Switch.....	4-5
B-1	Mode Switch Location on 2G4082-25	B-2
B-2	Memory Module Locations on the 2G4082-25	B-3
B-3	NEM Removal and DIMM Connector Location.....	B-4
B-4	Removing the Existing DIMM	B-4
B-5	Installing the DIMM	B-5
B-6	Removing Existing DRAM SIMM.....	B-6
B-7	Installing the DRAM SIMM	B-7

Tables

3-1	Contents of DFE-Platinum Module Carton	3-2
4-1	LANVIEW LEDs.....	4-2
4-2	Troubleshooting Checklist	4-4
A-1	Specifications for 2G4082-25	A-1
A-2	COM Port Pin Assignments.....	A-2
A-3	Compliance Standards	A-2

About This Guide

This guide provides an overview, installation and troubleshooting instructions, and specifications for the Enterasys Matrix® DFE-Platinum 2G4082-25 module.

For information about the CLI (Command Line Interface) set of commands used to configure and manage the DFE modules, refer to the *Enterasys Matrix DFE-Diamond/Platinum Series Configuration Guide*.



Note: In this guide, the following terms are used:

- *DFE* refers to Distributed Forwarding Engine series of modules.
- *DFE module* or *module* refers to the 2G4082-25.
- *Network expansion module* or *NEM* refers to an optional uplink card installed on the main logic board and accessible through the option slot of the 2G4082-25.
- *Mini-GBIC* (Mini-Gigabit Interface Card) refers to a smaller optional interface card that plugs into an optional network expansion module.

Important Notice

Depending on the firmware version used in the DFE module, some features described in this document may not be supported. Refer to the Release Notes shipped with the DFE module to determine which features are supported.

Who Should Use This Guide



Electrical Hazard: Only qualified personnel should perform installation procedures.

Riesgo Electrico: Solamente personal calificado debe realizar procedimientos de instalacion.

Elektrischer Gefahrenhinweis: Installationen sollten nur durch ausgebildetes und qualifiziertes Personal vorgenommen werden.

This guide is intended for a network administrator responsible for installing and setting up the DFE module.

How to Use This Guide

Read through this guide completely to familiarize yourself with its contents and to gain an understanding of the features and capabilities of the DFE module. A general working knowledge of data communications networks is helpful when setting up this module.

This preface provides an overview of this guide and the DFE-Platinum Series manual set, a brief summary of each chapter, and defines the conventions used in this document, and instructs how to obtain technical support from Enterasys Networks. To locate information about various subjects in this guide, refer to the following table:

For...	Refer to...
An overview of the DFE module	Chapter 1, Introduction
Network requirements that must be met before installing the DFE module	Chapter 2, Network Requirements
Instructions to install the DFE module hardware	Chapter 3, Installation
Troubleshooting installation problems and diagnosing network/operational problems using the LANVIEW LEDs	Chapter 4, Troubleshooting
Specifications, environmental requirements, and physical properties of the DFE module	Appendix A, Specifications
Instructions to set the mode switches when necessary and remove and replace DRAM SIMM and DIMM memory	Appendix B, Mode Switch Bank Settings and Optional Installations

Related Documents

The manuals listed below can be obtained from the World Wide Web in Adobe Acrobat Portable Document Format (PDF) at the following site:

<http://www.enterasys.com/support/manuals>

- *Enterasys Matrix DFE-Diamond/Platinum Series Configuration Guide* provides information on how to use the Command Line Interface to set up and manage the DFE modules.
- *Enterasys Matrix Network Expansion Module Hardware Installation Guide* provides instructions to install the Enterasys Matrix Network Expansion Modules (NEMs) and Mini-GBICs.
- *Cabling Guide* provides information on dB loss and cable specifications.

Unlike the *Enterasys Matrix DFE-Diamond/Platinum Series Configuration Guide*, the *Cabling Guide* is not listed alphabetically on the web site. Instead, it is listed under the *Overview Guides* link.

Conventions Used in This Guide

The following conventions are used in this guide.



Note: Calls the reader's attention to any item of information that may be of special importance.



Caution: Contains information essential to avoid damage to the equipment.

Precaución: Contiene información esencial para prevenir dañar el equipo.

Achtung: Verweist auf wichtige Informationen zum Schutz gegen Beschädigungen.



Electrical Hazard: Warns against an action that could result in personal injury or death due to an electrical hazard.

Riesgo Electrico: Advierte contra una acción que pudiera resultar en lesión corporal o la muerte debido a un riesgo eléctrico.

Elektrischer Gefahrenhinweis: Warnung vor sämtlichen Handlungen, die zu Verletzung von Personen oder Todesfällen – hervorgerufen durch elektrische Spannung – führen können!

Lowercase x: Indicates the general use of an alphanumeric character (for example, 6x1xx, the x's indicate a combination of numbers or letters).

Getting Help

For additional support related to the modules or this document, contact Enterasys Networks using one of the following methods:

World Wide Web	www.enterasys.com/services/support/
Phone	1-800-872-8440 (toll-free in U.S. and Canada) or 1-978-684-1000 For the Enterasys Networks Support toll-free number in your country: www.enterasys.com/services/support/contact/
Internet mail	support@enterasys.com To expedite your message, type [SWITCHING] in the subject line.
To send comments concerning this document to the Technical Publications Department: techpubs@enterasys.com	
Please include the document Part Number in your email message.	

Before contacting Enterasys Networks for technical support, have the following information ready:

- Your Enterasys Networks service contract number
- A description of the failure
- A description of any actions already taken to resolve the problem (for example, changing mode DFE-Platinum modules, rebooting the unit)
- The serial and revision numbers of all involved Enterasys Networks products in the network
- A description of your network environment (for example, layout, cable type)
- Network load and frame size at the time of trouble (if known)

- The device history (for example, have you returned the device before, is this a recurring problem)
- Any previous Return Material Authorization (RMA) numbers

Introduction

This chapter provides an overview of the DFE module capabilities, and introduces the 2G4082-25 DFE module.

For information about...	Refer to page...
Overview of DFE Series Capabilities	1-1
DFE-Platinum Module	1-2
Connectivity	1-4
Management	1-4
Secure Networks Policy Support	1-5
Standards Compatibility	1-5
LANVIEW Diagnostic LEDs	1-5

Overview of DFE Series Capabilities

The Platinum Distributed Forwarding Engine (DFE) is Enterasys' next generation of enterprise modules for the Matrix N-Series and Matrix E7 switches. These DFEs deliver high performance and flexibility to ensure comprehensive switching, routing, Quality of Service, security, and traffic containment. Key features include:

- Superior performance and capacity to support more high-bandwidth and latency sensitive applications
- 10/100/1000 Base-TX and 10 Gigabit Ethernet connectivity
- Integrated Services Design that reduces the number/ type of modules required, simplifies network design, and lowers entry cost
- Port- and User-Based Policy and Multilayer Packet Classification that provides granular control and security for business-critical applications
- High-availability services with stateful failover for services and management
- Self-learning configuration modules with increased reliability and fault tolerance that reduces configuration time and maximizes uptime
- Network-wide configuration, change, and inventory management that is easier to install, troubleshoot, and maintain
- Reduced support and maintenance costs, and decreased configuration time

DFE-Platinum Module

This section provides an overview of the 2G4082-25 DFE module ([Figure 1-1](#)). For information about features of the DFE-Platinum modules and how to configure them, refer to the *Enterasys Matrix DFE-Diamond/Platinum Series Configuration Guide*.

2G4082-25



Note: The DFE-Platinum 2G4082-25 module can be installed in the single-slot of the Matrix N1 chassis, or in any slot of the Matrix E7, Matrix N7, Matrix N5, or Matrix N3, but does not have FTM connectivity.

When installed in the Matrix E7, Matrix N7, Matrix N5, or Matrix N3, the 2G4082-25 will boot as a standalone device with no connectivity to other modules in the chassis.

The 2G4082-25 module has 24, 10BASE-T/100BASE-TX/1000BASE-T compliant ports by means of 24 fixed front-panel RJ45 connectors and a slot for an optional network expansion module (NEM).

Each of the fixed front panel ports can operate in either half-duplex or full-duplex mode of operation. The duplex mode can be determined by either auto-negotiation or manual configuration.

The DFE module ports can be configured to control traffic by limiting the rate of traffic accepted into the module and prioritizing traffic to expedite the flow of higher priority traffic through the module.

The DFE module receives power and backplane connectivity when it is inserted into a chassis.

Figure 1-1 DFE-Platinum 2G4082-25 Module

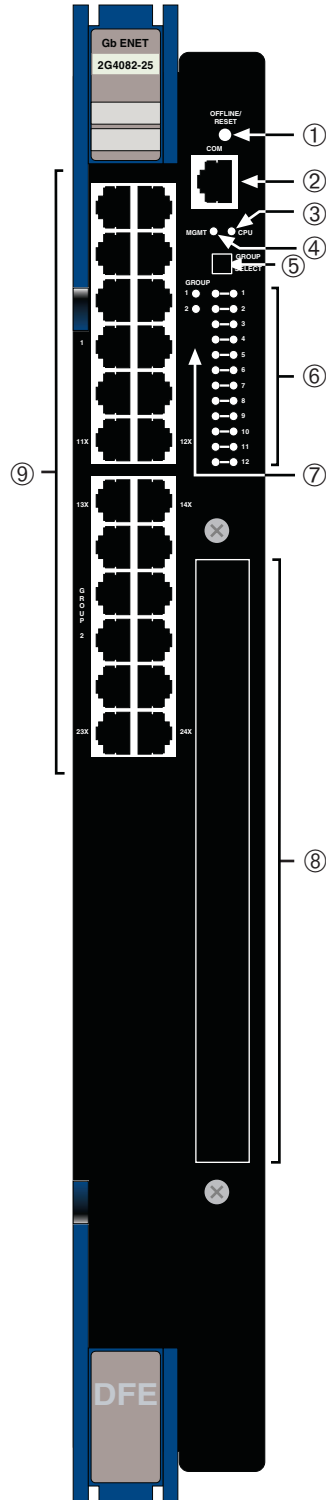

- | | | | |
|---|-------------------------|---|---|
| 1 | OFFLINE/RESET switch | 6 | GROUP status LEDs |
| 2 | RJ45 COM (Console Port) | 7 | GROUP selected LEDs |
| 3 | CPU LED | 8 | NEM option slot |
| 4 | MGMT LED | 9 | Ports (1-24) 10/100/1000 Mbps, via 24 RJ45s |
| 5 | GROUP SELECT button | | |

Network Expansion Module (NEM) Option

The 2G4082-25 option slot provides access to an installed network expansion module. Refer to the Enterasys Networks web site for a current listing of the available NEMs. Specific installation instructions are shipped with each NEM.

Connectivity

Depending on how the 2G4082-25 is configured, it can support up to:

- 24, 10BASE-T/100BASE-TX/1000BASE-T switched ports connected through 24, fixed RJ45 front panel connectors, or
- 24, 10BASE-T/100BASE-TX/1000BASE-T switched ports plus an optional network expansion module.

Management

Management of the module can be either in-band or out-of-band. In-band remote management is possible using Telnet, Enterasys Networks' NetSight[®] management application, or WebView[™] application. Out-of-band management is provided through the RJ45 COM (Communication) port on the front panel using a VT100 terminal or a VT100 terminal emulator.

Switch Configuration Using WebView

Enterasys Networks' HTTP-based Web management application (WebView) is an intuitive web tool for simple management tasks.

Switch Configuration Using CLI Commands

The CLI commands enable you to perform more complete switch configuration management tasks.

For CLI command set information and how to configure the module, refer to the *Enterasys Matrix DFE-Diamond/Platinum Series Configuration Guide*.

Secure Networks Policy Support

A fundamental concept that is key to the implementation of the Enterasys Secure Networks methodology is policy-enabled networking. This approach provides users of the network with the resources they need - in a secure fashion – while at the same time denying access to applications or protocols that are deemed inappropriate based on the user’s function within the organization. By adopting such a “user-personalized” model, it is possible for business policies to be the guidelines in establishing the technology architecture of the enterprise. Two major objectives are achieved in this way: IT services are matched appropriately with individual users; and the network itself becomes an active participant in the organization’s security strategy. The Secure Networks architecture consists of three tiers:

- Classification rules make up the first or bottom tier. The rules apply to devices in the Secure Networks environment, such as switches and routers. The rules are designed to be implemented at or near the user’s point of entry to the network. Rules may be written based on criteria defined in the Layer 2, Layer 3 or Layer 4 information of the data frame.
- The middle tier is Services, which are collections of individual classification rules, grouped logically to either permit or deny access to protocols or applications based on the user’s role within the organization. Priority and bandwidth rate limiting may also be defined in services.
- Roles, or behavioral profiles, make up the top tier. The roles assign services to various business functions or departments, such as executive, sales, and engineering.

To enhance security and deliver a true policy-based infrastructure, the Enterasys Secure Networks methodology can take advantage of authentication methods, such as 802.1X, using EAP-TLS, EAP-TTLS, or PEAP, as well as other types of authentication. Authorization information, attached to the authentication response, determines the application of policy. Authorization information is communicated via the policy name in a RADIUS Filter-ID attribute. An administrator can also define a role to be implemented in the absence of an authentication framework. Refer to the release notes shipped with the module for details.

Standards Compatibility

The DFE modules are fully compliant with the IEEE 802.3-2002, 802.3ae-2002, 802.1D-1998, and 802.1Q-1998 standards. The DFE module provides IEEE 802.1D-1998 Spanning Tree Algorithm (STA) support to enhance the overall reliability of the network and protect against “loop” conditions.

LANVIEW Diagnostic LEDs

LANVIEW diagnostic LEDs serve as an important troubleshooting aid by providing an easy way to observe the status of individual ports and overall network operations.

Network Requirements

This chapter provides information concerning the network requirements that must be met to ensure a satisfactory performance from the DFE module. The information consists of the following:

For information about...	Refer to page...
Link Aggregation	2-1
10BASE-T Network	2-2
100BASE-TX Network	2-2
1000BASE-T Network	2-2
1000BASE-SX/LX/ELX Network	2-2



Note: The *Matrix DFE-Diamond/Platinum Series Configuration Guide* and the *Cabling Guide* referred to in the following sections can be found on the Enterasys Networks World Wide Web site: <http://www.enterasys.com/support/manuals>

Refer to “[Related Documents](#)” in [About This Guide](#).

Link Aggregation

Link Aggregation is a method of grouping multiple physical ports on a network device into one logical link according to the IEEE 802.3ad-2002 standard. Because Link Aggregation is standards based, it allows for automatic configuration with manual overrides (if applicable), and can operate on 10 Mbps, 100 Mbps, or 1000 Mbps Ethernet full duplex ports. Thus the network administrator can combine a group of five 100 Mbps ports into a logical link (trunk) that functions as a single 500 Mbps port. As long as the modules agree on which ports are in the trunk, there are no problems with looping, and the Spanning Tree can treat this trunk as a single port.

In normal usage (and typical implementations) there is no need to enable/disable ports for Link Aggregation. The default values will result in the maximum number of aggregations possible. If the switch is placed in a configuration with its peers not running the protocol, no aggregations will be formed and the modules will function normally (that is, Spanning Tree will block redundant paths).

For details about the commands involved with configuring the Link Aggregation function, refer to the *Matrix DFE-Diamond/Platinum Series Configuration Guide*.

10BASE-T Network

When connecting a 10BASE-T segment to any of the fixed front panel ports of the 2G4082-25, ensure that the network meets the Ethernet network requirements of the IEEE 802.3-2002 standard for 10BASE-T. Refer to the *Cabling Guide* for details.



Note: If a port is to operate at 100 Mbps, Category 5 cabling must be used. Category 3 cabling does not meet 100 Mbps specifications. For 10 Mbps operation only, Category 3 or Category 5 cabling can be used. Refer to “[100BASE-TX Network](#)” on page 2-2 for information about 100BASE-TX networks and cabling.

100BASE-TX Network

The fixed front panel ports of the 2G4082-25 provide a connection that supports Category 5 UTP cabling. The device at the other end of the twisted pair segment must meet IEEE 802.3-2002 100BASE-TX Fast Ethernet network requirements for the devices to operate at 100 Mbps. Refer to the *Cabling Guide* for details.



Note: The fixed ports of the module support Category 5 UTP cabling with an impedance between 85 and 111 ohms for 100 Mbps operation. The module is capable of operating at 10, 100, or 1000 Mbps and can automatically sense the port speed of the other device and adjust its speed accordingly.

1000BASE-T Network

The 2G4082-25 supports 10/100/1000 Mbps by means of fixed RJ45 front panel connectors. These connections support copper wire connections that can operate up to 1000 Mbps. The device at the other end of the twisted pair segment must meet IEEE 802.3-2002 network requirements for the devices to operate at Gigabit speed.



Note: The fixed ports of each module support Category 5 UTP cabling with an impedance between 85 and 111 ohms for 100 and 1000 Mbps operation and can automatically sense the port speed of the other device and adjusts its speed accordingly.

1000BASE-SX/LX/ELX Network

The optional Mini-GBICs provide a Gigabit Ethernet connection to the optional network expansion modules to provide fiber-optic connections operating at 1000 Mbps (1 Gbps). Other Mini-GBICs may support different types of cabling connections. The device at the other end of the fiber-optic connection must meet IEEE 802.3-2002 Gigabit Ethernet requirements for the devices to operate at Gigabit speed. Refer to [Appendix A](#) for further details on Mini-GBIC specifications.

Installation



Electrical Hazard: Only qualified personnel should perform installation procedures.

Riesgo Electrico: Solamente personal calificado debe realizar procedimientos de instalacion.

Elektrischer Gefahrenhinweis: Installationen sollten nur durch ausgebildetes und qualifiziertes Personal vorgenommen werden.

Important Notice

Read the Release Notes shipped with the DFE-Platinum module to check for any exceptions to the supported features and operation documented in this guide.

This chapter provides the instructions to install the DFE-Platinum 2G4082-25 module.

Follow the order of the sections listed below to correctly install the module.

For information about...	Refer to page...
Unpacking the DFE-Platinum Module	3-2
Installing Optional Network Expansion Modules	3-2
Installing Module into Matrix E7 or N7 Chassis	3-2
Installing Module into Matrix N1, N3, or N5 Chassis	3-5
Connecting to the Network	3-6
Connecting to COM Port for Local Management	3-10
Completing the Installation of a New System	3-15

Unpacking the DFE-Platinum Module

Unpack the DFE-Platinum module as follows:

1. Open the box and remove the packing material protecting the DFE-Platinum module.
2. Verify the contents of the carton as listed in [Table 3-1](#).

Table 3-1 Contents of DFE-Platinum Module Carton

Item	Quantity
DFE-Platinum Module (2G4082-25)	1
This Installation Guide	1
Customer Release Notes	1

3. Remove the tape seal on the non-conductive bag to remove the DFE module.
4. Perform a visual inspection of the DFE-Platinum module for any signs of physical damage. Contact Enterasys Networks if there are any signs of damage. Refer to [“Getting Help”](#) on page xiii for details.

Installing Optional Network Expansion Modules



Note: Install any optional equipment before installing the 2G4082-25 into a chassis.

A Phillips screwdriver is needed to install an optional NEM into the 2G4082-25.

At the time of this printing, only the 7G-6MGBIC-A NEM is available for the 2G4082-25. Refer to your release notes for the latest available Ethernet interface modules. The 7G-6MGBIC-A provides six Gigabit port slots for optional Mini-GBIC connections.

Installing an optional NEM involves

- removing the coverplate from the DFE-Platinum module,
- attaching the NEM to the DFE-Platinum module, and
- if required, installing Mini-GBICs.

For more information, refer to the *Quick Reference* that was shipped with your NEM, or the *Matrix Network Expansion Module Hardware Installation Guide* located on the Enterasys Networks website.

Installing Module into Matrix E7 or N7 Chassis



Caution: Failure to observe static safety precautions could cause damage to the DFE module. Follow static safety handling rules and wear the antistatic wrist strap.

Do not cut the non-conductive bag to remove the module. Sharp objects contacting the board or components can cause damage.

Precaución: Si no toma las medidas de seguridad necesarias para evitar descargas de electricidad estática, es posible que el módulo se dañe. Siga los consejos de seguridad para la manipulación del producto y no olvide utilizar la pulsera antiestática.

No corte la bolsa antiestática para sacar el módulo. Tenga en cuenta que si algún objeto cortante entra en contacto con la placa o con los componentes, éstos podrían dañarse.

To install a 2G4082-25 into a Matrix E7 or Matrix N7 chassis, proceed directly to [“Preparation”](#) on page 3-3 to start the installation process.

Preparation

1. Remove the blank panel covering the module slot in which the module will be installed. All other slots must remain covered to ensure proper airflow for cooling. (Save the blank plate in the event you need to remove the module.)
2. Remove the module from the shipping box. (Save the box and packing materials in the event the module needs to be reshipped.)
3. Locate the antistatic wrist strap shipped with the chassis. Attach the antistatic wrist strap to your wrist and plug the cable from the antistatic wrist strap into the ESD grounding receptacle at the upper right corner of the chassis.
4. Remove the module from the plastic bag. (Save the bag in the event the module must be reshipped.) Observe all precautions to prevent damage from Electrostatic Discharge (ESD).
5. Examine the module for damage. If any damage exists, DO NOT install the module. Immediately contact Enterasys Networks. Refer to [“Getting Help”](#) on page xiii.

Installation



Note: The DFE-Platinum 2G4082-25 module can be installed in the single-slot of the Matrix N1 chassis, or in any slot of the Matrix E7, Matrix N7, Matrix N5, or Matrix N3, but does not have FTM connectivity.

When installed in the Matrix E7, Matrix N7, Matrix N5, or Matrix N3, the 2G4082-25 will boot as a standalone device with no connectivity to other modules in the chassis.

To install the module in the Matrix E7 or Matrix N7, refer to [Figure 3-1](#) and proceed as follows:



Caution: To prevent damaging the backplane connectors in the following step, take care that the module slides in straight and properly engages the backplane connectors.

Ensure that the top lever lines up with the desired slot number located on the front panel of the chassis. Refer to [Figure 3-1](#).

Precaución: Para evitar que se dañen los conectores del panel posterior en el siguiente paso, intente deslizar el módulo en forma recta y verifique que se enganche correctamente en los conectores de panel posterior.

Asegúrese de que la palanca superior esté alineada con respecto al número de ranura correspondiente ubicado en el panel frontal del chasis. Consulte en [Figure 3-1](#).

1. Locate the chassis card guides that line up with the slot number in which the module will be installed. (In this example, slot 1 is being used.) Make sure the module locking levers are in the open position (top and bottom).
2. Align the module card between the upper and lower card guides of the desired slot and slide it into the chassis, taking care that the module slides in straight. See Caution below.



Caution: Due to the amount of force needed to properly seat the module connectors into the backplane connectors, it is best to apply force to the end of the levers to insert (or eject) the module. Otherwise, damage could result to the module and chassis.

Precaución: Para colocar los conectores del módulo en los conectores del panel posterior correctamente es necesario hacer bastante fuerza, por ello, para insertar o quitar el módulo, se recomienda concentrar la fuerza en el extremo de las palancas. Si no lo hace, podría dañar el módulo y el chasis.

3. Slide the module into the slot until you can engage the top and bottom locking levers with the chassis as shown in [Figure 3-1](#).



Caution: In step 4, do not force the locking levers to the point that they touch the face of the front panel. Forcing the locking levers to this point could damage the module and chassis.

Precaución: En el paso 4, tenga cuidado de no llevar las palancas de cierre a un punto en donde estén en contacto con el panel frontal. Si lo hace, podría dañar el módulo y/o el chasis.

4. Refer to the Caution note above, then rotate the two levers into the closed position.
5. If the chassis in which the module is installed was powered down for the installation, turn the power supplies on. Check to see that the module CPU LED settles at solid green after a few minutes. If the LED does not turn solid green, refer to [Chapter 4](#) for troubleshooting details.



Caution: When setting the locking levers to the closed position, do not try to force the locking levers to the point that they touch the face of the front panel. Forcing the locking levers to this point could damage the module and chassis.

Precaución: Al mover las palancas a la posición de cerrado, tenga cuidado de no llevarlas a un punto en donde estén en contacto con el panel frontal. Si lo hace, podría dañar el módulo o el chasis.

Figure 3-1 Installing Module into Matrix E7 or Matrix N7 Chassis (E7 shown)

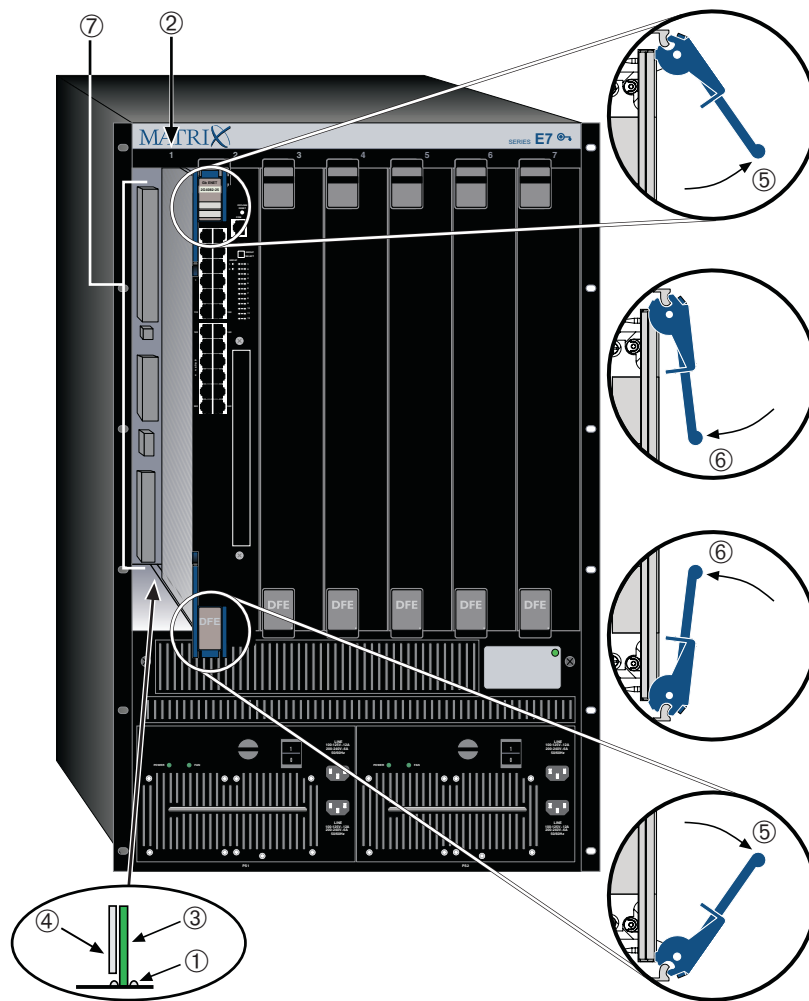

- | | |
|--|--|
| <ol style="list-style-type: none"> 1 Card guides 2 Slot number 1 (Left-most slot is 1.) 3 Module card 4 Metal back panel | <ol style="list-style-type: none"> 5 Upper/lower locking tabs (in proper open position) 6 Upper/lower locking tab (in closed position) 7 Backplane connectors |
|--|--|

Installing Module into Matrix N1, N3, or N5 Chassis



Caution: Failure to observe static safety precautions could cause damage to the DFE module. Follow static safety handling rules and wear the antistatic wrist strap.

Do not cut the non-conductive bag to remove the module. Sharp objects contacting the board or components can cause damage.

Precaución: Si no toma las medidas de seguridad necesarias para evitar descargas de electricidad estática, es posible que el módulo se dañe. Siga los consejos de seguridad para la manipulación del producto y no olvide utilizar la pulsera antiestática.

No corte la bolsa antiestática para sacar el módulo. Tenga en cuenta que si algún objeto cortante entra en contacto con la placa o con los componentes, éstos podrían dañarse.



Note: The DFE-Platinum 2G4082-25 module can be installed in the single-slot of the Matrix N1 chassis, or in any slot of the Matrix E7, Matrix N7, Matrix N5, or Matrix N3, but does not have FTM connectivity.

When installed in the Matrix E7, Matrix N7, Matrix N5, or Matrix N3, the 2G4082-25 will boot as a standalone device with no connectivity to other modules in the chassis.

The 2G4082-25 can be installed in the single slot of the Matrix N1 chassis, or any available chassis slot in the Matrix N3 chassis (slots 1 through 3), or Matrix N5 chassis (slots 1 through 5). These chassis have horizontal slots for DFE-Series modules. To install the module into the Matrix N1, N3, or N5 chassis, refer to [Figure 3-2](#) and proceed as described in “[Installing Module into Matrix E7 or N7 Chassis](#)” on page 3-2.



Caution: When setting the locking levers to the closed position, do not try to force the locking levers to the point that they touch the face of the front panel. Forcing the locking levers to this point could damage the module and chassis.

Precaución: Al mover las palancas a la posición de cerrado, tenga cuidado de no llevarlas a un punto en donde estén en contacto con el panel frontal. Si lo hace, podría dañar el módulo o el chasis.

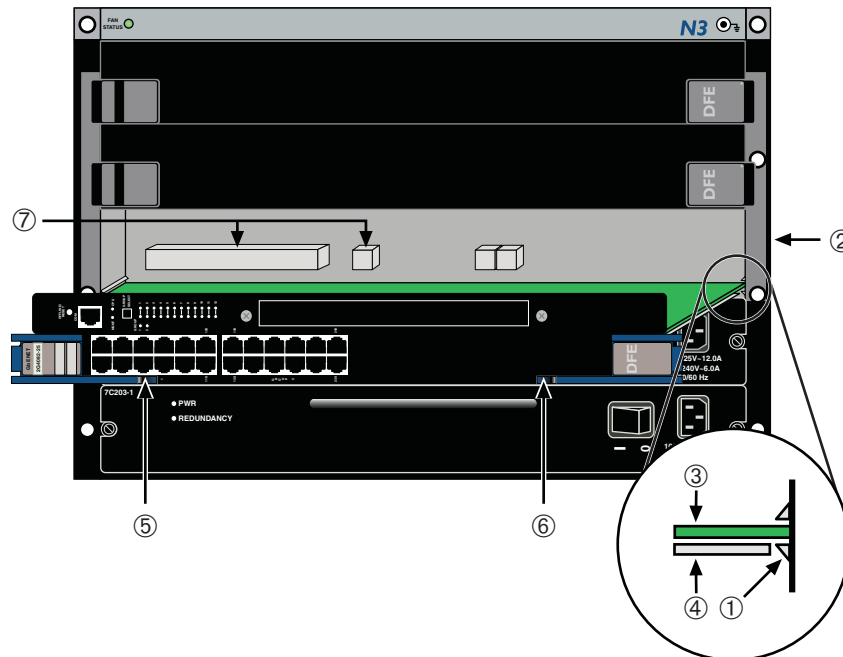
Figure 3-2 Installing Module into N3, N1, or N5 Chassis (N3 shown)

- | | |
|--------------------------------|--|
| 1 Card guides | 5 Upper locking tab (shown in closed position) |
| 2 Slot 1 (Top slot is slot 3.) | 6 Lower locking tab (shown in closed position) |
| 3 Module card | 7 Backplane connectors |
| 4 Metal back panel | |

Connecting to the Network

This section provides the procedures for connecting unshielded twisted pair (UTP) segments from the network or other devices to the 2G4082-25 (“[Connecting UTP Cables](#)” on page 3-6).



Note: If the DFE-Platinum module is being installed in a network using Link Aggregation, there are rules concerning network cables and port configurations that must be followed for Link Aggregation to operate properly. Before connecting the cables, refer to the *Enterasys Matrix DFE-Diamond/Platinum Series Configuration Guide* for the configuration information. For details on how to obtain manuals, refer to the “[Related Documents](#)” on page xii.

Connecting UTP Cables

The fixed RJ45 front panel connections of the 2G4082-25 are 10/100/1000 Mbps ports. These ports have internal crossovers, and also support automatic-polarity sensing when configured for automatic-negotiation.

If automatic-negotiation is not activated on a port, use a straight-through cable when connecting a workstation to the port. When connecting a networking device to the port, such as a bridge, repeater, or router, use a crossover cable.

If a port is set for auto-negotiation, automatic-polarity sensing is also activated. Automatic-polarity sensing eliminates the need for a crossover cable, regardless if the connection is to another network device or a workstation.



Note: All RJ45 front panel ports on the 2G4082-25 support Category 5 Unshielded Twisted Pair (UTP) cabling with an impedance between 85 and 111 ohms. Category 3 cable may be used if the connection is going to be used only for 10 Mbps.

Figure 3-3 shows connecting a twisted pair segment to the 2G4082-25 module. It is assumed that the chassis power is turned on to provide power to the module. Refer to Figure 3-3 and proceed as follows:

1. Ensure that the device connected to the other end of the segment is powered ON.
2. Connect the twisted pair segment to the module by inserting the RJ45 connector on the twisted pair segment into the appropriate RJ45 port connector.

Figure 3-3 Connecting a Twisted Pair Segment to the DFE-Platinum Module

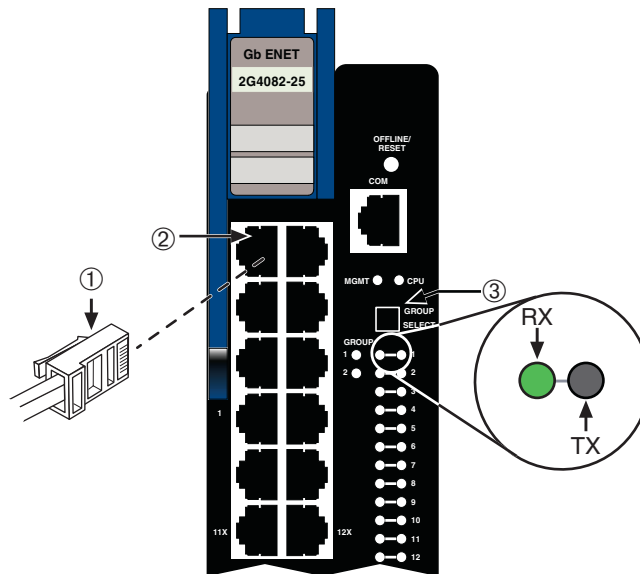

- | | | |
|------------------|--------------------------------|-----------------------|
| 1 RJ45 connector | 2 RJ45 port connector (port 1) | 3 GROUP SELECT button |
|------------------|--------------------------------|-----------------------|

3. Verify that a link exists by checking that the port RX (Receive) LED is ON (flashing amber, blinking green, or solid green). If the RX LED is OFF and the TX (Transmit) LED is not blinking amber, perform the following steps until it is on:
 - a. To view the receive and transmit activity on a group of segments, press the GROUP SELECT button (see Figure 3-3) to step to the group of interest (Groups 1 and 2). Each time the GROUP SELECT button is pressed, the GROUP LED lights up in sequence, indicating which Group is selected. The receive and transmit activity for that group of segments is then indicated by the RX and TX LEDs for each segment.
 - b. Verify that the cabling being used is Category 5 UTP with an impedance between 85 and 111 ohms. For the port to operate at 100 or 1000 Mbps, Category 5 cabling must be used and installed properly.
 - c. Verify that the device at the other end of the twisted pair segment is on and properly connected to the segment.
 - d. Verify that the RJ45 connectors on the twisted pair segment have the proper pinouts and check the cable for continuity. Typically, a crossover cable is used between hub devices. A straight-through cable is used to connect between switches or hub devices and an end user (computer). Refer to Figure 3-4 and Figure 3-5 for four-wire RJ45 connections. Refer to Figure 3-6 and Figure 3-7 for eight-wire RJ45 connections.

Figure 3-4 Four-Wire Crossover Cable RJ45 Pinouts, Connections Between Hub Devices

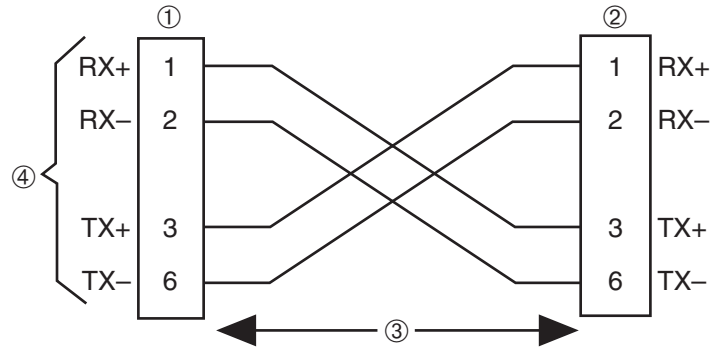

- 1 RJ45 device port
- 2 Other device port
- 3 RJ45-to-RJ45 crossover cable
- 4 RX+/RX- and TX+/TX- connections. These connections must share a common color pair.

Figure 3-5 Four-Wire Straight-Through Cable RJ45 Pinouts, Connections Between Switches and End User Devices

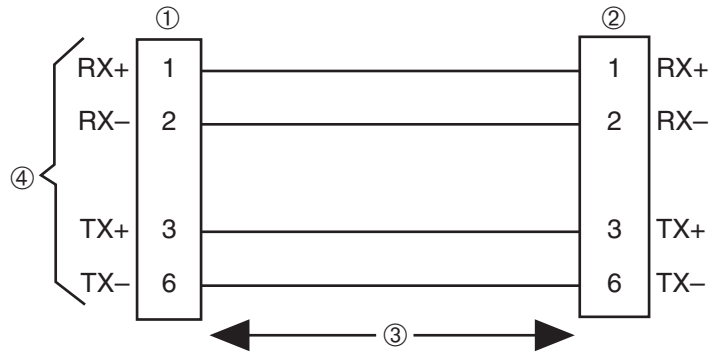

- 1 RJ45 device port
- 2 Other device port
- 3 RJ45-to-RJ45 straight-through cable
- 4 RX+/RX- and TX+/TX- connections. These connections must share a common color pair.

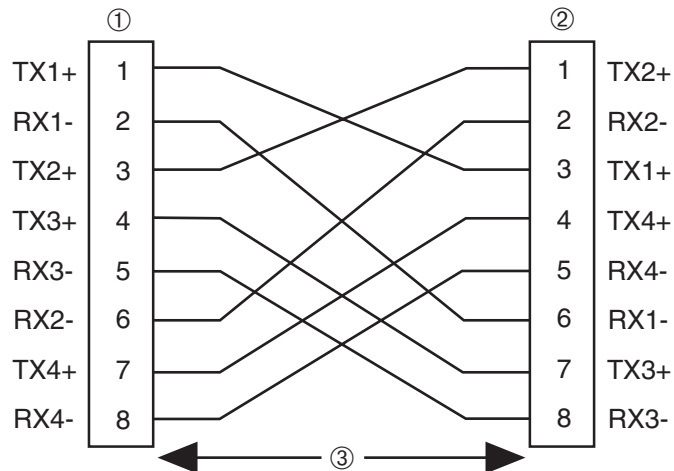
Figure 3-6 Eight-Wire Crossover Cable RJ45 Pinouts, Connections Between Hub Devices

- 1 RJ45 device port
 2 Other device port
 3 RJ45-to-RJ45 crossover cable

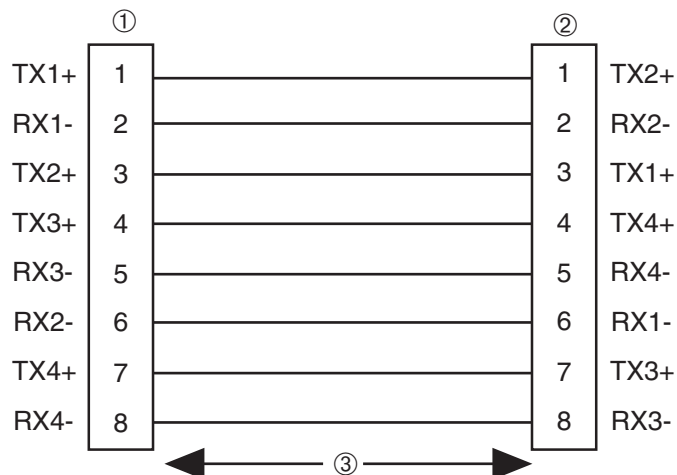
Figure 3-7 Eight-Wire Straight-Through Cable RJ45 Pinouts, Connections Between Switches and End-User Devices

- 1 RJ45 device port
 2 Other device port
 3 RJ45-to-RJ45 straight-through cable

- e. Ensure that the twisted pair connection meets the dB loss and cable specifications outlined in the *Cabling Guide*. Refer to "[Related Documents](#)" on page xii for information on obtaining this document. If a link is still not established, contact Enterasys Networks. Refer to "[Getting Help](#)" on page xiii for details.
4. Repeat steps 1 through 3 above, until all connections have been made.

Connecting to COM Port for Local Management

This section describes how to install a UTP straight-through cable with RJ45 connectors and optional adapters to connect a PC, a VT series terminal, or a modem to an Enterasys Networks module to access Local Management. This section also provides the pinout assignments of the adapters.

What Is Needed

The following is a list of the user-supplied parts that may be needed depending on the connection:

- RJ45-to-DB9 female adapter
- UTP straight-through cable with RJ45 connectors
- RJ45-to-DB25 female adapter
- RJ45-to-DB25 male adapter

With a UTP straight-through cable with RJ45 connectors and RJ45-to-DB9 adapter, you can connect products equipped with an RJ45 COM port to an IBM or compatible PC running a VT series emulation software package.

With a UTP straight-through cable and RJ45-to-DB25 female adapter, you can connect products equipped with an RJ45 COM port to a VT series terminal or VT type terminals running emulation programs for the VT series.

With a UTP straight-through cable and an RJ45-to-DB25 male adapter, you can connect products equipped with an RJ45 COM port to a Hayes compatible modem that supports 9600 baud.

Connecting to an IBM PC or Compatible Device

To connect an IBM PC or compatible device, running the VT terminal emulation, to an Enterasys Networks module COM port (Figure 3-8), proceed as follows:

1. Connect the RJ45 connector at one end of a UTP straight-through cable to the communications COM port on the Enterasys Networks module. (The COM port is also known as a Console port.)
2. Plug the RJ45 connector at the other end of the UTP straight-through cable into an RJ45-to-DB9 adapter.
3. Connect the RJ45-to-DB9 adapter to the communications port on the IBM PC.
4. Turn on the PC and configure your VT emulation package with the following parameters:

Parameter	Setting
Mode	7 Bit Control
Transmit	Transmit=9600
Bits Parity	8 Bits, No Parity
Stop Bit	1 Stop Bit

5. When these parameters are set, the startup screen will display. Refer to the appropriate *Enterasys Matrix DFE-Diamond/Platinum Series Configuration Guide* for further information.

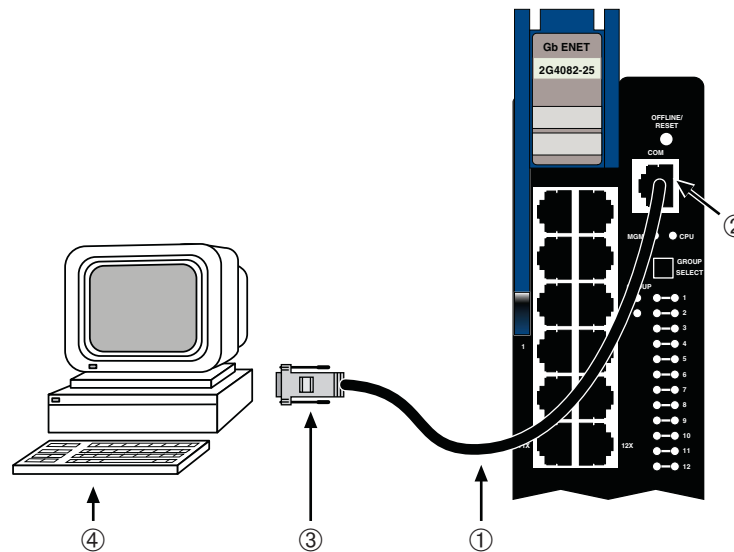
Figure 3-8 Connecting an IBM PC or Compatible

- | | |
|---|-------------------------------|
| 1 UTP straight-through cable with RJ45 connectors | 3 RJ45-to-DB9 PC adapter |
| 2 RJ45 COM port | 4 IBM PC or compatible device |

Connecting to a VT Series Terminal

To connect a VT Series terminal to an Enterasys Networks DFE-Platinum module COM port (Figure 3-9), use a UTP straight-through cable with RJ45 connectors and an RJ45-to-DB25 female adapter, and proceed as follows:

1. Connect the RJ45 connector at one end of the UTP straight-through cable to the COM port on the Enterasys Networks module.
2. Plug the RJ45 connector at the other end of the UTP straight-through cable into the RJ45-to-DB25 female adapter.
3. Connect the RJ45-to-DB25 adapter to the port labeled COMM on the VT terminal.
4. Turn on the terminal and access the Setup Directory. Set the following parameters on your terminal:

Parameter	Setting
Mode	7 Bit Control
Transmit	Transmit=9600
Bits Parity	8 Bits, No Parity
Stop Bit	1 Stop Bit

When these parameters are set, the Local Management password screen will display. Refer to the *Enterasys Matrix DFE-Diamond/Platinum Series Configuration Guide* for further information.

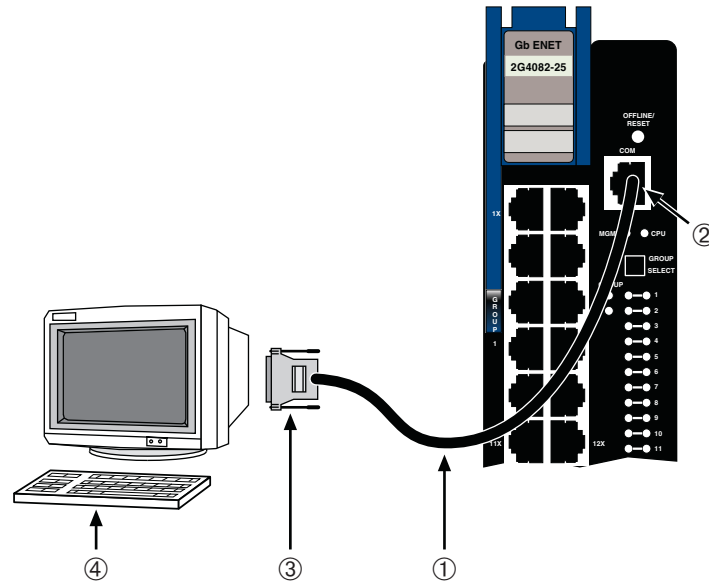
Figure 3-9 Connecting a VT Series Terminal

- | | |
|---|---------------------------|
| 1 UTP straight-through cable with RJ45 connectors | 3 RJ45-to-DB25 VT adapter |
| 2 RJ45 COM port | 4 VT series terminal |

Connecting to a Modem

To connect a modem to an Enterasys Networks DFE-Platinum module COM port (Figure 3-10), use a UTP straight-through cable with RJ45 connectors and an RJ45-to-DB25 male adapter, and proceed as follows:

1. Connect the RJ45 connector at one end of the UTP straight-through cable to the COM port of the DFE-Platinum module.
2. Plug the RJ45 connector at the other end of the UTP straight-through cable into the RJ45-to-DB25 modem adapter.
3. Connect the RJ45-to-DB25 adapter to the communications port on the modem.
4. Turn on the modem.
5. With a PC connected to a remote modem, you can configure the switch remotely. To accomplish this, you must configure your PC VT emulation package with the following parameters.

Parameter	Setting
Mode	7 Bit Control
Transmit	Transmit=9600
Bits Parity	8 Bits, No Parity
Stop Bit	1 Stop Bit

6. When these parameters are set, the Local Management password screen will display. Refer to the *Enterasys Matrix DFE-Diamond/Platinum Series Configuration Guide* for further information.

Figure 3-10 Connecting to a Modem

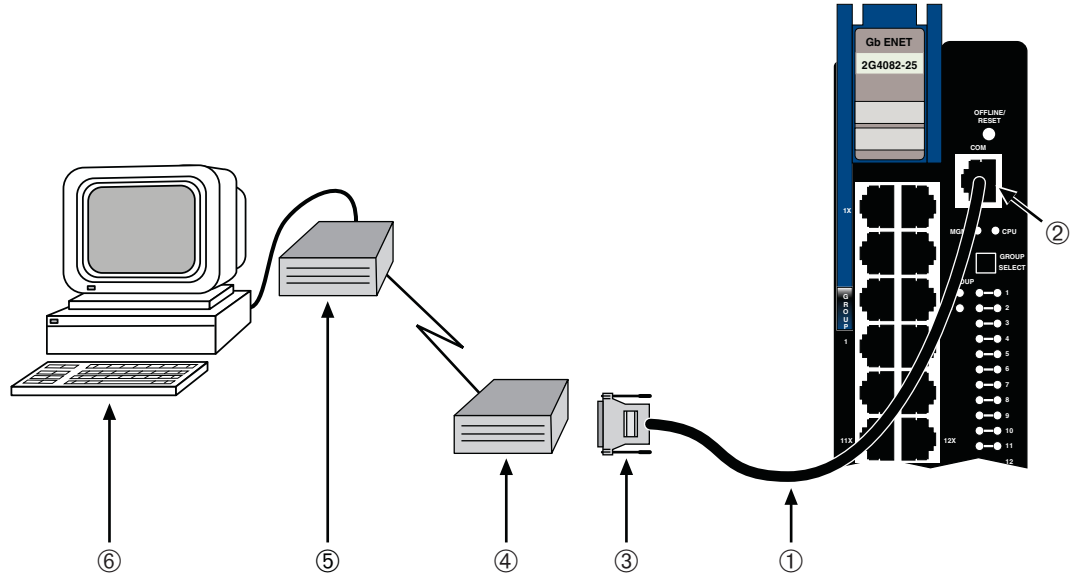

- 1 UTP straight-through cable with RJ45 connectors
- 2 RJ45 COM port
- 3 RJ45-to-DB25 modem adapter
- 4 Local modem
- 5 Remote modem
- 6 Remote PC

Adapter Wiring and Signal Assignments

COM Port Adapter Wiring and Signal Diagram			
RJ45		DB9	
Pin	Conductor	Pin	Signal
1	Blue	2	Receive (RX)
4	Red	3	Transmit (TX)
5	Green	5	Ground (GRD)
2	Orange	7	Request to Send (RTS)
6	Yellow	8	Clear to Send (CTS)

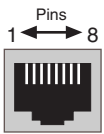
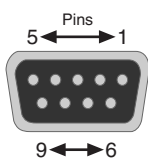
 <p>RJ45 Connector (Female)</p>	 <p>DB9 Connector (Female)</p>
--	---

VT Series Port Adapter Wiring and Signal Diagram

RJ45		DB25	
Pin	Conductor	Pin	Signal
4	Red	2	Transmit (TX)
1	Blue	3	Receive (RX)
6	Yellow	5	Clear to Send (CTS)
5	Green	7	Ground (GRD)
2	Orange	20	Data Terminal Ready

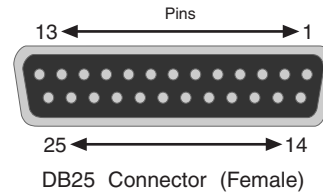
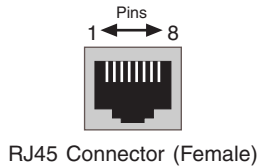

Modem Port Adapter Wiring and Signal Diagram

RJ45		DB25	
Pin	Conductor	Pin	Signal
1	Blue	2	Transmit (TX)
2	Orange	8	Data Carrier Detect (DCD)
4	Red	3	Receive
5	Green	7	Ground (GRD)
6	Yellow	20	Data Terminal Ready (DTR)
8	Gray	22	Ring Indicator

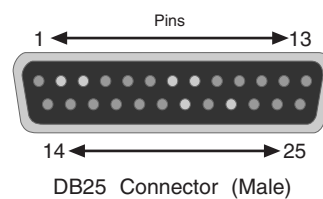
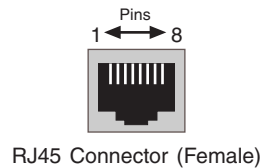

Completing the Installation of a New System



Note: The DFE-Platinum 2G4082-25 module can be installed in the single-slot of the Matrix N1 chassis, or in any slot of the Matrix E7, Matrix N7, Matrix N5, or Matrix N3, but does not have FTM connectivity.

When installed in the Matrix E7, Matrix N7, Matrix N5, or Matrix N3, the 2G4082-25 will boot as a standalone device with no connectivity to other modules in the chassis.

The 2G4082-25 becomes the management module on the Matrix chassis power up. A complete list of the factory default values are provided in the *Enterasys Matrix DFE-Diamond/Platinum Series Configuration Guide*.

After installing the 2G4082-25 into the chassis and making the connections to the network, proceed to “[First-Time Log-In Using a Console Port Connection](#)” on page 3-15, to access the module management startup screen from your PC, terminal, or modem connection.

First-Time Log-In Using a Console Port Connection



Note: This procedure applies only to initial log-in, and to logging in to a device not yet configured with administratively-supplied user and password settings.

By default, the Matrix DFE Series device is configured with three user login accounts: **ro** for Read-Only access; **rw** for Read-Write access; and **admin** for super-user access to all modifiable parameters. The default password is set to blank (carriage return). For information on changing these default passwords, refer to the *Enterasys Matrix DFE-Diamond/Platinum Series Configuration Guide*.

Start the Command Line Interface (CLI) from the module’s local console port as follows:

1. Connect a terminal to the local console port as described in “[Connecting to COM Port for Local Management](#)” on page 3-10. The startup screen, [Figure 3-11](#), displays.
2. At the login prompt, enter one of the following default user names:
 - **ro** for Read-Only access,
 - **rw** for Read-Write access, or
 - **admin** for Super User access. (This access level allows Read-Write access to all modifiable parameters, including user accounts.)
3. Press **Enter**.
4. The Password prompt displays. Leave this string blank and press **Enter**. The module information and Matrix prompt displays as shown in [Figure 3-11](#).

The DFE-Platinum module is now ready to be configured. For information about setting the IP address and configuring Telnet settings for remote access to DFE management, refer to the *Enterasys Matrix DFE-Diamond/Platinum Series Configuration Guide*. The CLI commands enable you to initially set up and perform more involved management configurations.

The *Enterasys Matrix DFE-Diamond/Platinum Series Configuration Guide* is available online at:

<http://www.enterasys.com/support/manuals>

If you require assistance, contact Enterasys Networks using one of the methods described in “[Getting Help](#)” on page xiii.

Figure 3-11 Matrix DFE Startup Screen Example (N7 Chassis)

```
login: admin
Password:

M A T R I X N7
Command Line Interface

Enterasys Networks, Inc.
50 Minuteman Rd.
Andover, MA 01810-1008 U.S.A.

Phone: +1 978 684 1000
E-mail: support@enterasys.com
WWW: http://www.enterasys.com

(c) Copyright Enterasys Networks, Inc. 2003

Chassis Serial Number: xxxxxxxxxxxxxx
Chassis Firmware Revision: xx.xx.xx

Matrix N7(su)->
```

Logging in with an Administratively-Configured User Account

If the device's default user account settings have been changed, proceed as follows:

1. At the login prompt, enter your administratively-assigned user name and press **Enter**.
2. At the Password prompt, enter your password and press **Enter**.

The notice of authorization and the Matrix prompt displays as shown back in [Figure 3-11](#).



Note: Users with Read-Write (rw) and Read-Only (ro) access can use the **set password** command to change their own passwords. Administrators with Super User (su) access can use the **set system login** command to create and change user accounts, and the **set password** command to change any local account password. For information on the set password and set system login commands, refer to the *Enterasys Matrix DFE-Diamond/Platinum Series Configuration Guide*.

The DFE-Platinum module is now ready to be configured. For information about setting the IP address and configuring Telnet settings for remote access to DFE management, refer to the *Enterasys Matrix DFE-Diamond/Platinum Series Configuration Guide*. The CLI commands enable you to initially set up and perform more involved management configurations.

The *Enterasys Matrix DFE-Diamond/Platinum Series Configuration Guide* is available online at:

<http://www.enterasys.com/support/manuals>

If you require assistance, contact Enterasys Networks using one of the methods described in [“Getting Help”](#) on page xiii.

Troubleshooting

This chapter provides information concerning the following:

For information about...	Refer to page...
Using LANVIEW	4-1
Troubleshooting Checklist	4-4
Overview of DFE-Platinum Module Shutdown Procedure	4-5
Recommended Shutdown Procedure	4-6
Last Resort Shutdown Procedure	4-6

Unless otherwise noted, the following information applies to all DFE modules.

Using LANVIEW

The modules use a built-in visual diagnostic and status monitoring system called LANVIEW. The LANVIEW LEDs ([Figure 4-1](#)) allow quick observation of the network status to aid in diagnosing network problems.

About the Management (MGMT) LED

The MGMT LED (shown in [Figure 4-1](#)) indicates when the module is serving as the Management Module to control the management functions for all DFE-Platinum modules in the chassis. The Management Module handles all IP requests to the chassis IP address, such as PING, Telnet, SNMP, and HTTP. The Management Module also handles the CLI configuration sessions by means of the console port. So, when you plug into a DFE-Platinum module COM port to configure a module in the chassis, it is handled by the Management Module regardless of the DFE-Platinum module COM port that you use.

Viewing the Receive and Transmit Activity

On the 2G4082-25, you can view the receive and transmit activity on the RX and TX LEDs. However, only one group of 12 ports may be viewed at a time.

To view the receive and transmit activity on a group of attached segments, press the GROUP SELECT button (see [Figure 4-1](#)) to step to the group of interest (Groups 1 or 2). Each time the GROUP SELECT button is pressed, the GROUP LED lights up in sequence, indicating which group is selected. The receive and transmit activity for that group of segments is then indicated by the RX and TX LEDs for each port.

Figure 4-1 LANVIEW LEDs

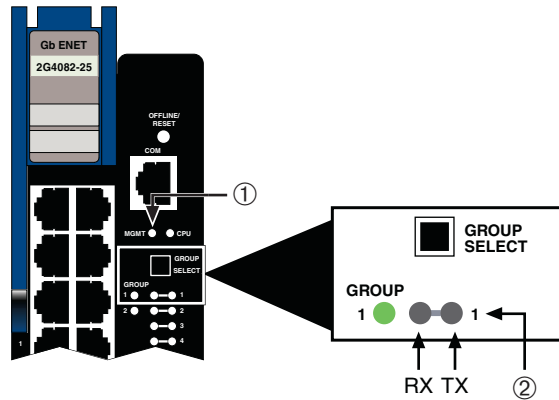

1 MGMT LED

2 Group 1, Port 1 LEDs

Table 4-1 describes the LED indications and provides recommended actions as appropriate.



The terms used in Table 4-1 indicate the following:

- **Flashing** indicates an LED is flashing randomly.
- **Blinking** indicates an LED is flashing at a steady rate (approximately 50% on, 50% off).
- **Solid** indicates a steady LED light. No pulsing.
- **Alternating** indicates an LED is flashing in a steady rate other than 50% on, 50% off.

Table 4-1 LANVIEW LEDs

LED	Color	State	Recommended Action
MGMT	None	Off. This module is NOT the Management Module.	None.
	Green	Solid. This module is the designated Management Module.	None.
	Amber	Flashing. This is a temporary indication that the module is saving data.	None.

Table 4-1 LANVIEW LEDs (continued)

LED	Color	State	Recommended Action
CPU	None	Power off.	Ensure chassis has adequate power.
	Amber	Blinking. Module in process of booting.	None.
		Solid. Testing.	If the LED remains amber for several minutes, contact Enterasys Networks for technical support.
	Green	Blinking. Image starts running.	None.
		Solid. Functional.	None.
	Red	Solid. Processor in reset.	None.
	Green and Amber	Blinking. Indicates that the module is in the process of shutting down.	None. This state is activated when the OFFLINE/RESET switch is pressed for less than 1 second to a start the process of an orderly shutdown. While in this state, do not remove any DFE-Platinum module.
Amber and off	Alternating (67% on, 33% off). Indicates that a shutdown process has completed. This indication will remain for 60 seconds before automatically restarting.	While in this state, you have 60 seconds to safely remove the DFE-Platinum module from the chassis.	
RX (Receive)	None	No link. No activity. Port enabled or disabled.	None.
	Green	Solid. Link present, port enabled, no traffic is being received by the interface.	None.
	Amber	Flashing. Link present, port enabled, traffic is being received by the interface.	None.
	Red	Blinking. Indicates collisions. This indication is only supported on 10/100 ports.	Contact Enterasys Networks for technical support.
TX (Transmit)	None	Port enabled, but no activity.	If it is known that the port should be active and is not, contact Enterasys Networks for technical support.
	Green	Flashing. Indicates data transmission activity. Rate of flashing indicates the data rate.	None.
	Red	Flashing. Fault or Error (collision).	None, unless there is a high rate of activity. In this case, check for network configuration problems or a defective device.

Troubleshooting Checklist

If the module is not working properly, refer to [Table 4-2](#) for a checklist of problems, possible causes, and recommended actions to resolve the problem.

Table 4-2 Troubleshooting Checklist

Problem	Possible Cause	Recommended Action
All LEDs are OFF.	Loss of power.	Ensure that the module was installed properly according to the installation instructions in Chapter 3 , and that the host chassis is providing power.
No Local Management Password screen.	Incorrect terminal setup.	Refer to the <i>Enterasys Matrix DFE-Diamond/Platinum Series Configuration Guide</i> for proper setup procedures.
	Improper console cable pinouts.	Refer to Appendix A for proper COM port pinouts.
	Corrupt firmware image, or hardware fault.	If possible, attempt to download the image to the module again. Refer to the section, “ Setting the Mode Switches ,” on page B-1 for instructions to clear NVRAM.
Cannot navigate beyond Password screen.	Improper username/ password combination entered.	If the username/password combination has been forgotten, refer to the section, “ Setting the Mode Switches ,” on page B-1 for instructions on how to set the mode switch to reset the username/password combination to the default values.
Cannot contact the module through in-band management.	IP address not assigned.	Refer to the <i>Enterasys Matrix DFE-Diamond/Platinum Series Configuration Guide</i> for the IP address assignment procedure.
	Port is disabled.	Enable port. Refer to the <i>Enterasys Matrix DFE-Diamond/Platinum Series Configuration Guide</i> for instructions to enable/disable ports.
	Host Port policy and/or management VLAN is incorrectly configured, or not configured.	Verify that a management VLAN exists and that it is associated with the Host Port. Refer to the <i>Enterasys Matrix DFE-Diamond/Platinum Series Configuration Guide</i> for information about Host Port and management VLAN configuration.
	No link to device.	Verify that all network connections between the network management station and the module are valid and operating. If the problem continues, contact Enterasys Networks for technical support.
Port(s) goes into standby for no apparent reason.	Loop condition detected.	Verify that Spanning Tree is enabled. Refer to the <i>Enterasys Matrix DFE-Diamond/Platinum Series Configuration Guide</i> for the instructions to set the type of STA. Review the network design and delete unnecessary loops. If the problem continues, contact Enterasys Networks for technical support.

Table 4-2 Troubleshooting Checklist (continued)

Problem	Possible Cause	Recommended Action
User parameters (IP address, device and module name, etc.) were lost when the module power was cycled, the front panel OFFLINE/RESET switch was pressed.	Position of Mode switch (7), Persistent Data Reset, was changed sometime before either cycling power or pressing the OFFLINE/RESET switch, causing the user-entered parameters to reset to factory default settings. Clear Persistent Data that was set through Local Management. The module was moved either from slot-to-slot or from chassis-to-chassis.	Reenter the lost parameters as necessary. Refer to the <i>Enterasys Matrix DFE-Diamond/Platinum Series Configuration Guide</i> for the instructions to configure the device. If the problem continues, contact Enterasys Networks for technical support.

Overview of DFE-Platinum Module Shutdown Procedure



Caution: Do not remove a DFE module from an operating chassis system before reading the following information and instructions.

Precaución: Antes de retirar los módulos DFE del chasis en funcionamiento, lea las siguientes instrucciones y la información suministrada.

The DFE-Platinum module must shut down in an orderly fashion to ensure that the other modules in the system and other devices on the network are notified of the impending change. The devices can then make intelligent decisions and stabilize the network before the change is made; thereby increasing network availability.

You can shut down a DFE-Platinum module in an operating system using the OFFLINE/RESET switch shown in [Figure 4-2](#). There are two procedures to shut down a DFE-Platinum module.

- [“Recommended Shutdown Procedure”](#) (page 4-6)
- [“Last Resort Shutdown Procedure”](#) (page 4-6)

Figure 4-2 OFFLINE/RESET Switch

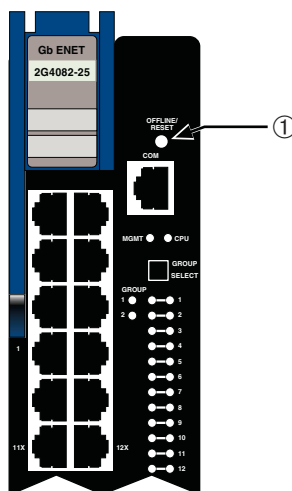

1 OFFLINE/RESET switch

Recommended Shutdown Procedure



Caution: Do not remove a DFE module from an operating chassis system before reading the following information and instructions.

Precaución: Antes de retirar los módulos DFE del chasis en funcionamiento, lea las siguientes instrucciones y la información suministrada.

Before pulling a DFE-Platinum module out of a chassis,

press or tap on its OFFLINE/RESET switch for less than 1 second.

Its CPU LED changes from solid green to blinking between green and amber, indicating that the module is shutting down. At the end of the shutdown routine, the CPU LED changes to a 67%/33% sequence of amber/off, respectively, indicating the module is in a halt state. In this time it is safe to restart or remove the module from the chassis.

When a controlled shutdown is initiated from the OFFLINE/RESET switch, you have 60 seconds from the time the CPU starts alternately flashing amber/off until the device automatically restarts.



Note: The only safe time to pull a DFE-Platinum module out of the chassis is when the CPU LED is alternately flashing amber/off. Otherwise, system operation will be interrupted.

Last Resort Shutdown Procedure



Caution: This method of shutting down a DFE module is not recommended except as a last resort, because all processes currently running on the module will be interrupted resulting in loss of frames.

Precaución: No se recomienda utilizar este método para apagar los módulos DFE. Recorra a él sólo como último recurso, puesto que interrumpe todos los procesos del módulo en funcionamiento, lo que podría resultar pérdidas de frames.

To reset a DFE-Platinum module without it performing an orderly shutdown routine,

press and hold the OFFLINE/RESET switch for approximately 6 seconds.

Pulling any DFE-Platinum module out of the chassis before it has been shut down is not recommended. The only safe time to pull a module out of the chassis is after the completion of a shutdown and the management LED is alternately flashing amber/off.



Specifications

This appendix provides information about the following:

For information about...	Refer to page...
DFE-Platinum Module Specifications	A-1
COM Port Pinout Assignments	A-2
Regulatory Compliance	A-2

Enterasys Networks reserves the right to change the specifications at any time without notice.

DFE-Platinum Module Specifications

[Table A-1](#) provides the I/O ports, processors and memory, physical, and environmental module specifications for the 2G4082-25.

Table A-1 Specifications for 2G4082-25

Item	Specification
Ports	
Ports 1 through 24	Twenty-four 10BASE-T/100BASE-TX/1000BASE-T compliant ports through twenty-four RJ45 connectors.
Network Expansion Module option slot	Supports one optional NEM.
Processors/Memory	
Processor	MPC750CX, 400 MHz processor
Dynamic Random Access Memory (DRAM)	128 MB
FLASH Memory	32 MB
Physical	
Dimensions	46.43 H x 6.05 W x 29.51 D (cm) 18.28 H x 2.38 W x 11.62 D (in.)
Approximate Weight	Gross: 5.54 kg (12.0 lb) (shipping carton containing one module) Net: 4.10 kg (9.0 lb) (one module without packaging)
Calculated hours for Mean Time Between Failures (MTBF) for the 2G4082-25	Refer to the MTBF web site at URL http://www.enterasys.com/support/mtbf/

Table A-1 Specifications for 2G4082-25 (continued)

Item	Specification
Environmental	
Operating Temperature	5°C to 40°C (41°F to 104°F)
Storage Temperature	-30°C to 73°C (-22°F to 164°F)
Operating Relative Humidity	5% to 90% (non-condensing)

COM Port Pinout Assignments

The COM port is a serial communications port for local access to Local Management. Refer to [Table A-2](#) for the COM port pin assignments.

Table A-2 COM Port Pin Assignments

Pin	Signal Name	Input/Output
1	Transmit Data (XMT)	Output
2	Clear to Send (CTS)	Input
3	Data Set Ready (DSR)	Input
4	Receive Data (RCV)	Input
5	Signal Ground (GND)	NA
6	Request to Send (RTS)	Output
7	Data Terminal Ready (DTR)	Output
8	Data Carrier Detect (DCD)	Input

Regulatory Compliance

The 2G4082-25 meets the safety and electromagnetic compatibility (EMC) requirements listed in [Table A-3](#):

Table A-3 Compliance Standards

Regulatory Compliance	Standards
Safety	UL 60950, CSA C22.2 No. 60950, 2006/95/EC, EN 60950, IEC 60950, EN 60825, 21 CFR 1040.10.
Electromagnetic Compatibility (EMC)	47 CFR Parts 2 and 15, CSA C108.8, 2004/108/EC, EN 55022, EN 61000-3-2, EN 61000-3-3, EN 55024, AS/NZS CISPR 22, VCCI V-3.

Mode Switch Bank Settings and Optional Installations

This appendix covers the following items:

For information about...	Refer to page...
Required Tools	B-1
Setting the Mode Switches	B-1
Memory Locations and Replacement Procedures	B-2

Required Tools

Use the following tools to perform the procedures provided in this appendix:

- Antistatic wrist strap
- Phillips screwdriver



Caution: An antistatic wrist strap is required to perform the following procedures to minimize ESD damage to the devices involved.

Precaución: Para minimizar los efectos de las descargas de electricidad estática, deberá utilizar una pulsera antiestática al realizar los siguiente procedimientos.

Setting the Mode Switches



Caution: Read the appropriate sections to be fully aware of the consequences when changing switch settings.

Only qualified personnel should change switch settings.

Precaución: Si desea modificar la configuración del interruptor, lea las secciones correspondientes para saber cuál será el resultado de hacerlo.

Estas modificaciones a la configuración sólo debe realizarlas personal calificado.

Figure B-1 shows the location of the mode switches and the switch settings for normal operation. These switches are set at the factory to the off position and rarely need to be changed.

Switch definitions and positions are as follows:

- Switches 1 through 6 – For Enterasys Networks use only.
- Switch 7 – Clear Persistent Data. Changing the position of this switch clears Persistent Data on the next power-up of the module. All user-entered parameters, such as the IP address or module names, are reset to the factory default settings. Once the module resets, you can either use the factory default settings or reenter your own parameters.

- Switch 8 – Clear Admin Password. Changing the position of this switch clears the admin password, and restores the factory default password on the next power-up of the module. Once the module resets, you can either use the factory default settings or reenter your own password.



Note: Do not change the position of Switch 8 unless it is necessary to reset the admin password to its factory default setting.

Figure B-1 Mode Switch Location on 2G4082-25

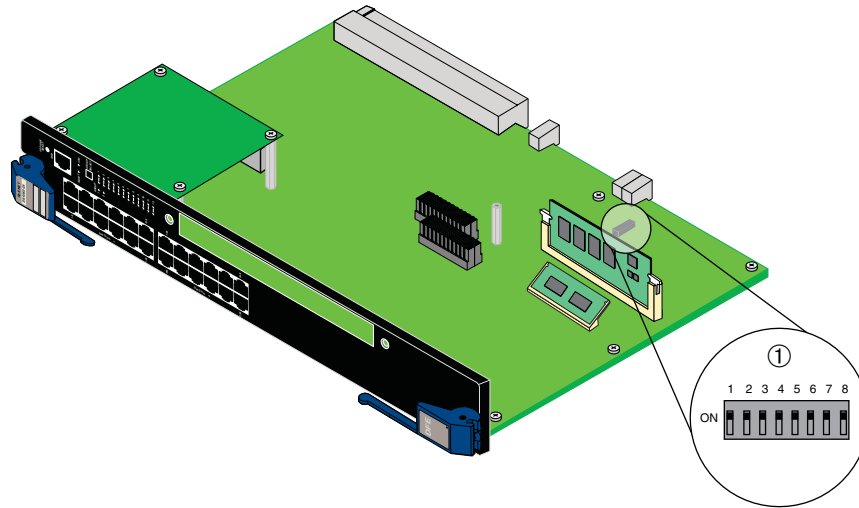

1 Mode switch bank

Memory Locations and Replacement Procedures

In the event that the Dual In-Line Memory Module (DIMM) or DRAM Single In-line Memory Module (SIMM) needs to be replaced, the following sections describe how to access, locate, and replace these memory modules. If you have questions concerning the replacement of either memory module, refer to [“Getting Help”](#) on page xiii for details on how to contact Enterasys Networks.

Location of Memory Modules

Figure B-2 shows the locations of the DRAM SIMM and DIMM on the main board of the 2G4082-25.

Figure B-2 Memory Module Locations on the 2G4082-25

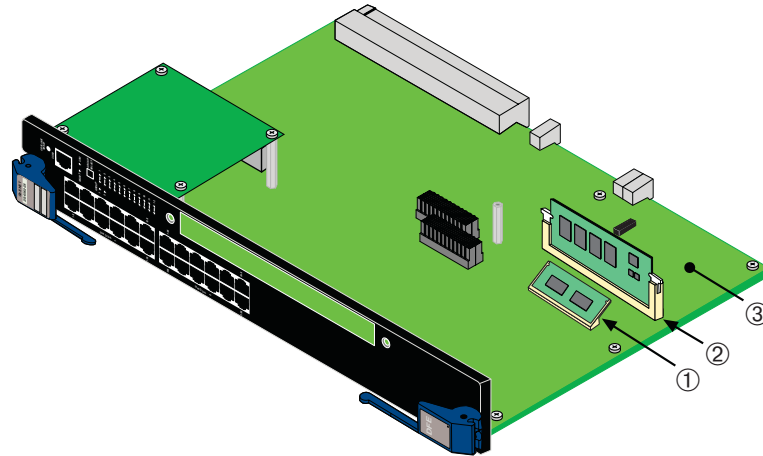

1 Flash DIMM

2 DRAM SIMM

3 Main PC board

Flash DIMM Replacement Procedure



Caution: Observe all Electrostatic Discharge (ESD) precautions when handling sensitive electronic equipment.

Precaución: Al trabajar con equipos electrónicos sensibles, tome todas las precauciones de seguridad para evitar descargas de electricidad estática.

Removing the DIMM from 2G4082-25

To remove the DIMM from the 2G4082-25, proceed as follows:



Note: Prior to removing the DIMM from a 2G4082-25, you must remove the NEM to gain access to the DIMM memory and connector.

1. If an optional network expansion module (NEM) is installed on the main board of the 2G4082-25, refer to [Figure B-3](#) on page B-4 and proceed to step 1a. Otherwise proceed to step 2.
 - a. Remove and save the three screws attaching the NEM to the front panel and to the standoff on the main PC board.
 - b. Lift the NEM straight up and off the two module connectors on the main PC board.

Figure B-3 NEM Removal and DIMM Connector Location

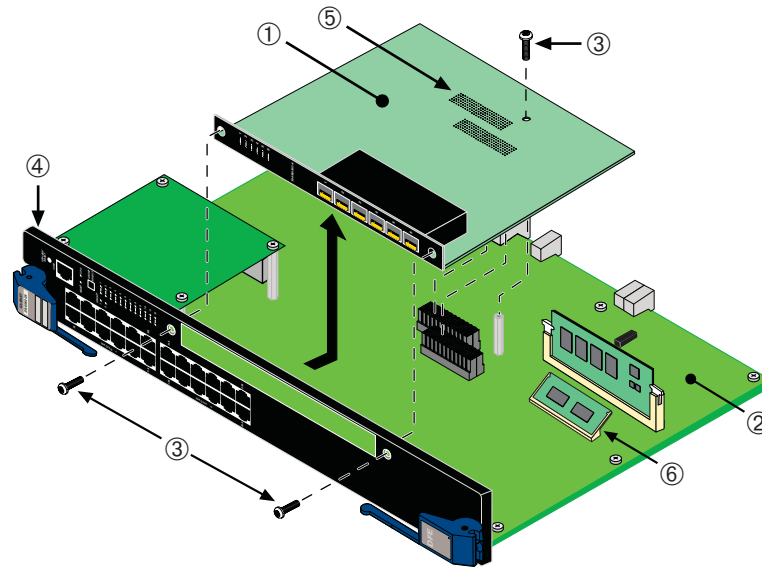

- | | |
|------------------|-----------------------------------|
| 1 NEM (optional) | 4 Module front panel |
| 2 Main PC board | 5 Module connectors on main board |
| 3 Screws (3) | 6 DIMM memory module |
-

2. Refer to [Figure B-4](#). Push the connector arms away from the DIMM and simultaneously lift the DIMM enough to release it from the connector fingers.

Figure B-4 Removing the Existing DIMM

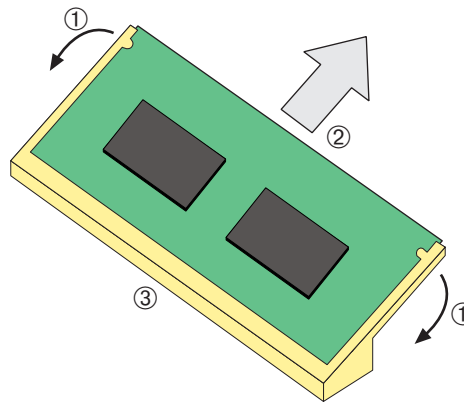

- | | | |
|------------------|--------|---------------------|
| 1 Connector arms | 2 DIMM | 3 Connector fingers |
|------------------|--------|---------------------|
-

3. Rotate the DIMM upwards, then remove it from the connector fingers.

Installing the DIMM



Caution: Observe all Electrostatic Discharge (ESD) precautions when handling sensitive electronic equipment.

Precaución: Al trabajar con equipos electrónicos sensibles, tome todas las precauciones de seguridad para evitar descargas de electricidad estática.

To install a DIMM, refer to [Figure B-5](#) and proceed as follows:

1. Insert the DIMM down between the connector fingers.
2. Pivot the DIMM downward so the tabs on the connector arms align with the two DIMM alignment notches. With the two connector arms spread outward, push the DIMM down between the connector arms. Then release the two connector arms to lock the DIMM into place.

Figure B-5 Installing the DIMM

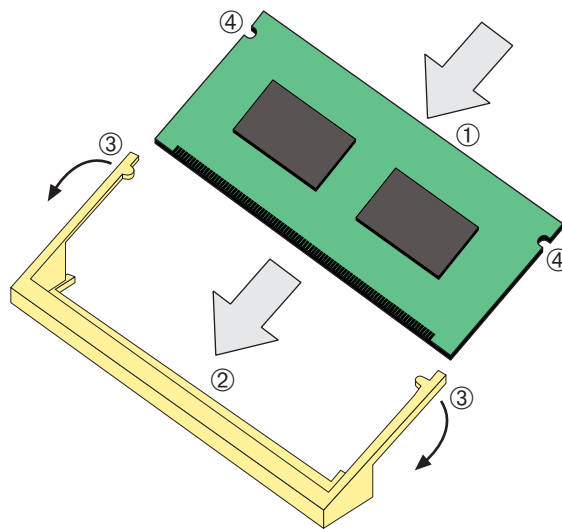

1 DIMM

2 Connector fingers

3 Connector arms

4 DIMM alignment notches (2)

DRAM SIMM Replacement Procedure



Caution: Observe all Electrostatic Discharge (ESD) precautions when handling sensitive electronic equipment.

Precaución: Al trabajar con equipos electrónicos sensibles, tome todas las precauciones de seguridad para evitar descargas de electricidad estática.

Removing the DRAM SIMM

To remove the existing DRAM SIMM, proceed as follows:

1. Locate the DRAM SIMM connector on the main PC board. Refer back to [Figure B-2](#).
2. Push the connector arms away from the DRAM SIMM, as shown in [Figure B-6](#), enough to release the DRAM SIMM from the connector contacts.

Figure B-6 Removing Existing DRAM SIMM

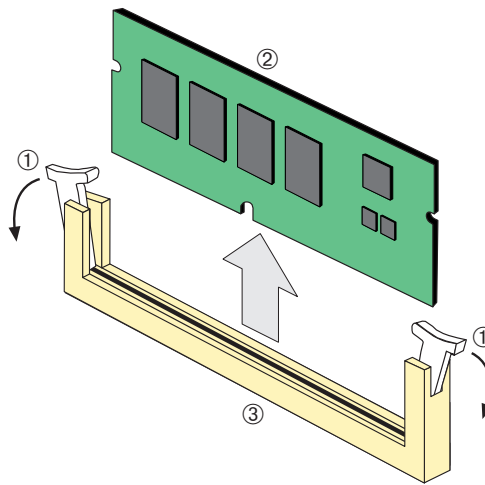

1 Connector arms 2 DRAM SIMM 3 Connector contacts

3. Pull the DRAM SIMM straight up and remove it from the connector contacts.

Installing the DRAM SIMM



Caution: Observe all Electrostatic Discharge (ESD) precautions when handling sensitive electronic equipment.

Precaución: Al trabajar con equipos electrónicos sensibles, tome todas las precauciones de seguridad para evitar descargas de electricidad estática.

To install a DRAM SIMM, refer to [Figure B-7](#) and proceed as follows:

1. Push the connector arms away from the DRAM SIMM enough to insert the DRAM SIMM into the connector contacts.
2. Insert the DRAM SIMM straight down between the connector contacts enough for the tabs on the connector arms to align with the two DRAM SIMM alignment notches.
3. Push the DRAM SIMM down into the connector contacts. Then rotate the two connector arms toward the DRAM SIMM to lock it into place.

Figure B-7 Installing the DRAM SIMM

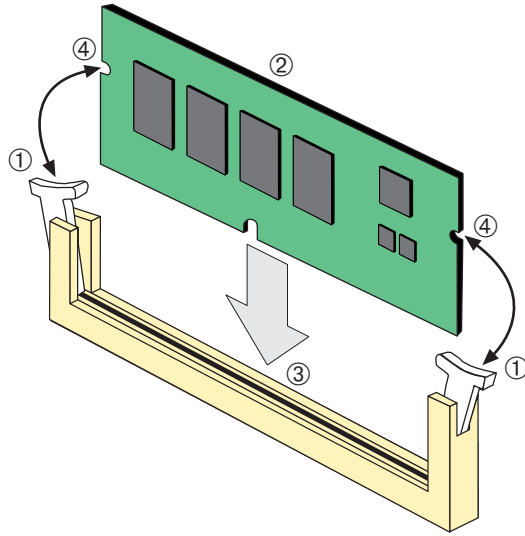

- | | |
|----------------------------|-----------------------------------|
| 1 DRAM SIMM Connector arms | 3 Connector contacts |
| 2 DRAM SIMM | 4 DRAM SIMM alignment notches (2) |

Numerics

- 1000BASE-SX/LX/ELX network connections requirements for [2-2](#)
- 1000BASE-T network connections requirements for [2-2](#)
- 100BASE-TX requirements [2-2](#)
- 10BASE-T connection [3-6](#) requirements [2-2](#)
- 2G4082-25 introduction to [1-2](#)

C

- Cable connections [2G4082-25](#) [3-6](#)
- Cable specifications
 - 1000BASE-SX/LX/ELX network [2-2](#)
 - 1000BASE-T network [2-2](#)
 - 100BASE-TX network [2-2](#)
 - 10BASE-T network [2-2](#)
- CLI command introduction to [1-4](#)
- COM port connections what is needed [3-10](#)
- Connecting to the network [3-6](#)
- Console port pinout assignments [A-2](#)

D

- DFE-Platinum module introduction to [1-2](#) overview of capabilities [1-1](#) specifications for [A-1](#)

DIMM

- replacement procedures for [B-2](#)

E

- Electromagnetic Compatibility (EMC) requirements [A-2](#)

G

- Getting help [xiii](#)
- GROUP SELECT button use of the [4-1](#)

I

- Installation
 - connecting to the Network [3-6](#)
 - module into Matrix E7 and N7 chassis [3-2](#)
 - module into Matrix N1, N3, N5 chassis [3-5](#)
 - optional network expansion module [3-2](#)

L

- LANVIEW Diagnostic LEDs use of [1-5](#)
- LANVIEW LEDs use of [4-1](#)
- Local Management
 - COM port connections [3-10](#)
 - introduction to [1-4](#)
- Login administratively configured [3-16](#)

M

- Management (MGMT) LED function of [4-1](#)
- Management, of module [1-4](#)
- Matrix E7 and N7 chassis module installation into [3-2](#)
- Matrix N1, N3, N5 chassis module installation into [3-5](#)
- Memory locations DIMM and SIMM [B-2](#)
- Mode Switch setting of [B-1](#)
- Module features [1-2](#)

N

- Network connecting to [3-6](#)
- Network Requirements list of [2-1](#)

O

- Optional network expansion module installation of [3-2](#)

P

- Pinout assignments console port [A-2](#)
- Pinouts
 - crossover [3-8](#), [3-9](#)
 - straight-through [3-8](#), [3-9](#)
- Policy Support [1-5](#)

R

- Receive LEDs viewing of [4-1](#)
- Regulatory Compliance [A-2](#)
- Related manuals obtaining [xii](#)
- Required tools [B-1](#)

S

- Safety requirements [A-2](#)
- Secure Networks Policy Support description of [1-5](#)
- SIMMs
 - installing DRAM SIMM [B-6](#)
 - location [B-3](#)

- Specifications [A-1](#)
 - DFE-Platinum module [A-1](#)
- Standards compatibility [1-5](#)
- Support [1-5](#)

T

- Technical support contacting Enterasys for [xiii](#)
- Transmit LEDs viewing of [4-1](#)
- Troubleshooting [4-1](#) checklist for [4-4](#)

U

- Unpacking the module [3-2](#)
- User Personalized Networks. **See** Secure Networks Policy Support

V

- Viewing Receive and Transmit Activity instructions for [4-1](#)

W

- WebView introduction to [1-4](#)

