

# DS3- Quad 10/100 RIOP Installation Guide

Compatible Systems Corporation  
4730 Walnut Street  
Suite 102  
Boulder, Colorado 80301

303-444-9532  
800-356-0283  
<http://www.compatible.com>

DS3-Quad 10/100 RIOP Installation Guide, Version 1.0  
Copyright© 1999, Compatible Systems Corporation

All rights reserved. VSR, VSR-2, MicroRouter and CompatiView are trademarks of Compatible Systems Corporation. Other trademarks are the property of their respective holders.

**FCC Notice:** This product has been certified to comply with the limits for a Class A computing device, pursuant to Subpart J of Part 15 of FCC Rules. It is designed to provide reasonable protection against radio or television communication interference in a commercial environment. Operation of this equipment in a residential area could cause interference with radio or television communication.

## Table of Contents

<b>Introduction to the DS3-Quad 10/100 RIOP</b>	<b>1</b>
<hr/>	
<b>Chapter 1 - Network Installation</b>	<b>2</b>
<hr/>	
Connecting the DS3-Quad 10/100 to the Ethernet	2
DS3 Line Connection Requirements	2
Connecting the DS3-Quad 10/100 to a DS3 Line	3
Connecting a Management Console	3
Powering Up the Router	3
<b>Chapter 2 - Quickstart Instructions</b>	<b>4</b>
<hr/>	
ETHERNET INTERFACE CONFIGURATION	4
IP Protocol	4
Required for IP	4
Suggested for IP	5
IPX Protocol	5
Required for IPX	5
Suggested for IPX	5
AppleTalk Protocol	5
Required for AppleTalk	5
Suggested for AppleTalk	5
DECnet Protocol	5
Required for DECnet	5
Suggested for DECnet	6
WAN INTERFACE CONFIGURATION	6
Internal DS3 CSU/DSU Physical Communications Settings	6
Required for Dedicated Line Operation	6
Suggested for Dedicated Line Operation	6
PPP Configuration	6
Internal DS3 CSU/DSU Link Configuration	6
Required for Dedicated Line Operation	6
Suggested for Dedicated Line Operation	6
IP Protocol	6
Required for IP	6
Suggested for IP	6
IPX Protocol	7
Required for IPX	7
AppleTalk Protocol	7
Required for AppleTalk	7
DECnet Protocol	7
Required for DECnet	7
Frame Relay Configuration	7
Internal DS3 CSU/DSU Link Configuration	7
Required for Dedicated Line Operation	7
Suggested for Dedicated Line Operation	8
Frame Relay DLCI Mappings	8

## Table of Contents

IP Protocol	8
Required for IP Numbered Interface	8
Required for IP Unnumbered Interface	8
Suggested for IP	8
IPX Protocol	9
Required for IPX	9
Suggested for IPX	9
AppleTalk Protocol	9
Required for AppleTalk	9
Suggested for AppleTalk	9
DECnet Protocol	9
Required for DECnet	9
SMDS Configuration	10
Link Configuration	10
Suggested for Dedicated/Leased Line Operation	10
SMDS Addressing	10
SAVING A CONFIGURATION FILE TO FLASH ROM	10
<b>Chapter 3 - Shipping Defaults</b>	<b>11</b>
<hr/>	
Ethernet Interfaces	11
IP Routing Defaults	11
IP Bridging Defaults	11
IPX Routing Defaults	11
IPX Bridging Defaults	11
AppleTalk Routing Defaults	11
AppleTalk Bridging Defaults	11
DECnet Defaults	11
WAN Interface	11
IP Defaults	11
IPX Defaults	11
AppleTalk Defaults	11
DECnet Defaults	11
DS3 CSU/DSU Defaults	11
<b>Chapter 4 - LED Patterns</b>	<b>12</b>
<hr/>	
ROUTER LED PATTERNS	12
Over Temp	12
Sys Ready	12
General Indicators	12
DS3-QUAD 10/100 RIOP LED PATTERNS	13
Ethernet Traffic Indicators	13
DS3 Indicators	13
Ethernet Connection Indicators	13
DS3 Connection Indicators	13

---

# Introduction to the DS3-Quad 10/100 RIOP

The DS3-Quad 10/100 Routing Input/Output Processor (RIOP), as part of the VSR multi-gigabit switching router, allows you to connect a remote corporate network and up to four local Ethernet segments. The DS3 interface has a data capacity of 44.736 Mbps, while the Ethernet interfaces can operate at either 10 Mbps or 100 Mbps.

This section of the manual contains information specific to the DS3-Quad 10/100 RIOP. It is divided into the following sections:

## **Chapter 1: Network Installation**

Here you will find step-by-step instructions on how to physically install the DS3-Quad 10/100 and connect it to your network.

## **Chapter 2: Quickstart Configuration**

The Quickstart section provides a basic list of parameters that must be entered into the DS3-Quad 10/100 for proper operation.

## **Chapter 3: Shipping Defaults**

This section of the manual lists factory defaults for each interface.

## **Chapter 4: LED Patterns**

This section of the manual describes the LED indicators for the DS3-Quad 10/100.

# Chapter 1 - Network Installation

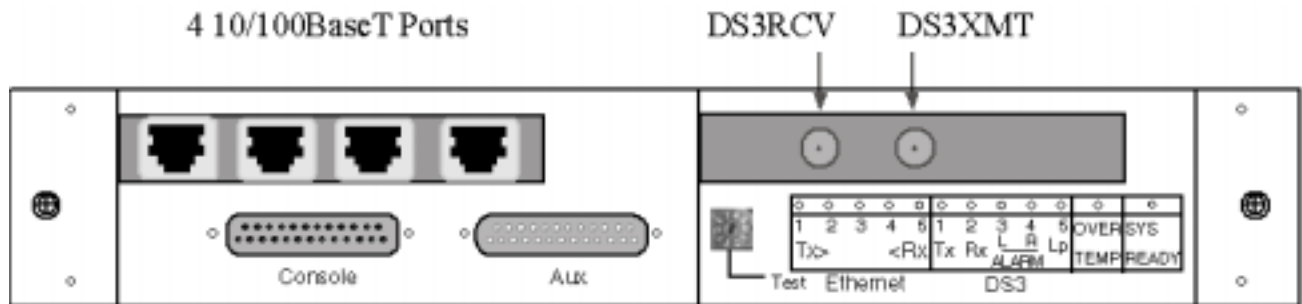

DS3-Quad 10/100 RIOP Front Panel

This section of the manual will help you install the DS3-Quad 10/100 RIOP to connect a local Ethernet and remote corporate network. These connections can be made to other Compatible Systems routers or routers from other vendors.

In summary, the steps for installation are:

1. After mounting the router or placing on a desktop, make sure it is not connected to any power source.
2. Connect the router to the Ethernet network.
3. Connect the router to the DS3 transmission equipment.
4. Connect a management console to the router (optional).
5. Plug in the power cable and power up the router.

## Connecting the DS3-Quad 10/100 to the Ethernet

The 10/100 Ethernet interfaces directly support 100BaseTx or 10BaseT twisted-pair Ethernet. To connect one of the router's Ethernet interfaces to twisted-pair Ethernet cabling, you will need an unshielded twisted-pair station cable that is already connected to a 10BaseT-compatible twisted-pair hub (for a transmit speed of 10 Mbps) or a 100Mbps Fast Ethernet hub (for a transmit speed of 100 Mbps).

❖ **Note:** *Ethernet cables and cable connectors are not supplied with the DS3-Quad 10/100 RIOP product. Category 5 cabling is required for 100 BaseT operation. Please contact your reseller or your Compatible Systems representative for information on obtaining the correct Ethernet cabling supplies.*

To connect the router to the twisted-pair network, simply plug the twisted-pair cable into the RJ-45 Ethernet connector on the front of the unit.

## DS3 Line Connection Requirements

The DS3-Quad 10/100 RIOP includes an integrated DS3 CSU/DSU. To connect this interface to your DS3 transmission equipment, you will need two coaxial cables.

These cables require special tools to be built correctly. You can use your approved cable supplier or you can contact your reseller or your Compatible Systems representative for a list of cable suppliers. To have a cable built, use the following specifications:

- Cable Type: AT&T type 734A or equivalent
- Connector Type: AMP Incorporated 413589-7 or equivalent (75 Ohm BNC plug)
- Maximum Length: 900 feet

---

❖ **Note:** *The DS3-Quad 10/100 RIOP includes loopback features which can be used to check the functionality of your DS3 line. Before attempting to route network traffic, use these features to check the line's basic integrity.*

## Connecting the DS3-Quad 10/100 to a DS3 Line

The DS3 line port consists of two 75 ohm BNC female coaxial connectors labeled DS3 XMT and DS3 RCV. To connect the router to the DS3 line, you need two AT&T type 734A or equivalent coaxial cables.

Install one cable between the router's DS3 XMT connector and the RCV connector on the DS3 transmission equipment. Install the other cable between the router's DS3 RCV connector and the XMT connector on the DS3 transmission equipment.

## Connecting a Management Console

If you wish to connect an out-of-band management console, use the supplied DB-25 male to DB-25 female console cable and connect to the Console interface on the DS3-Quad 10/100 RIOP. You can use a dumb terminal or a computer equipped with VT100 terminal emulation.

The default settings for the Console interface are VT100 terminal emulation, 9600 bps, 8 bits, no parity, 1 stop bit and no Flow Control.

❖ **Note:** *The DS3-Quad 10/100 RIOP also has an AUX interface. This is a modem connection which should only be used in consultation with Compatible Systems Technical Support staff, who will provide instruction on its use.*

## Powering Up the Router

Connect the supplied power cord to the front of the VSR and set the power switch to "On." At power-up, the router will take approximately one minute to become visible to CompaView.

❖ **Note:** *If you want to use Telnet as a management method, you must first configure an IP address into the router with an out-of-band console, or reconfigure the IP address on an IP host or workstation on the same Ethernet segment as the router. See the appropriate VSR chassis section of the manual for more information on Command Line Management.*

---

## Chapter 2 - Quickstart Instructions

This Quickstart chapter briefly discusses the major parameters that must be set in order to use the DS3-Quad 10/100 RIOP as part of your VSR multigigabit switching router.

Detailed information on the meaning of the router's parameters is provided in the *CompatiView Management Software Reference Guide* and the *Text-Based Configuration and Command Line Management Reference Guide*. You should use this chapter as a starting point to look up more specific information in the other documents.

If you need more general information on IP, IPX, AppleTalk or wide area protocols, see the Appendices in the *CompatiView Management Software Reference Guide*.

There are a number of parameter settings which are optional, in the sense that they are not required for all installations. These settings are not covered in this chapter.

In this chapter:

**CV** = CompatiView

**TB** = Text-Based Configuration

In order to successfully connect to an Internet Service Provider (ISP), you must use router configuration parameters which will be provided by the technical staff of the ISP. These parameters must include all IP addresses, WAN settings and any applicable authorization routines. Please check with your ISP **before** changing the configuration of your DS3-Quad 10/100 RIOP.

❖ **Note:** *This Quickstart does not include information on setting up packet filters for using the router as a Firewall. See the **CompatiView Management Software Reference Guide** or **Text-Based Configuration and Command Line Management Reference Guide** regarding IP packet filters for more information.*

### Ethernet Interface Configuration

Ethernet interfaces are considerably easier to set up than WAN interfaces since there are fewer choices that need to be made regarding communications protocols and parameters. We recommend that you begin by configuring any Ethernet interface parameters before proceeding to configure WAN interface parameters.

#### IP Protocol

##### Required for IP

These parameters set the basic address characteristics of the interface. They provide enough information for another IP node to find the interface (such as a Telnet client), but not enough information for routing to take place.

- IP address
- IP subnet mask
- IP broadcast address

**CV:** Use the TCP/IP Routing: Ethernet Dialog Box to set these parameters.

**TB:** Use the **configure** command and the **IPAddress**, **SubnetMask**, and **IPBroadcast** keywords in the **IP Ethernet 0** (and/or other port numbers you wish to configure) section.



### Suggested for IP

These parameters help supply information about the segment that the interface is connected to. With this information, routing can take place.

- Set IP RIP 1, IP RIP 2 or OSPF (Open Shortest Path First)
- Set IP static routes

**CV:** Use the TCP/IP Routing: Ethernet Dialog Box to set RIP, and the IP Static Routing Dialog Box (under Global/IP Static Routes) to set static routes. OSPF can only be configured using text-based configuration.

**TB:** Use **configure** and set either the **RIPVersion** keyword or the **OSPFEnabled** keyword for the **IP Ethernet 0** (and/or other port numbers you wish to configure) section. Use **edit config** and add static routes in the **IP Static** section.

## IPX Protocol

### Required for IPX

Generally, there are no required changes from the shipping Ethernet configuration for IPX. The Ethernet interface will autoconfigure to use the two most common IPX frame types, and will adapt to conditions on the Ethernet.

### Suggested for IPX

You may want to set your own network numbers, rather than using the autoconfigured values. You may also want to turn off unused frame types.

**CV:** Use the IPX Routing: Ethernet Dialog Box.

**TB:** Use **configure** and set keywords in the **IPX Ethernet 0** (and/or other port numbers you wish to configure) section.

## AppleTalk Protocol

### Required for AppleTalk

There are generally no required changes from the shipping Ethernet configuration for AppleTalk. The Ethernet interface will autoconfigure to use AppleTalk Phase 2, and will adapt to conditions on the Ethernet.

### Suggested for AppleTalk

You may want to set your own network numbers, rather than using the autoconfigured values. You may also want to use more meaningful zone names.

**CV:** Use the AppleTalk Routing: Ethernet Dialog Box.

**TB:** Use **configure** and set keywords in the **AppleTalk Phase 2 Ethernet 0** (and/or other port numbers you wish to configure) section.

## DECnet Protocol

### Required for DECnet

The router's shipping configuration does not have DECnet turned on. In order to be used, DECnet must be turned on both globally and for a particular port.

- Set DECnet on (globally, and for this port)
- Set DECnet area
- Set DECnet node

**CV:** Use the DECnet Routing Dialog Box (under Global/DECnet Routing) and the DECnet: Ethernet Dialog Box.

**TB:** Use **configure** and set the **Mode** keyword in the **DECnet Ethernet** (and/or other port

numbers you wish to configure) section. Use **configure** and set the **Enabled**, **Area**, and **Node** keywords in the **DECnet Global** section.

❖ **Note:** *Setting DECnet on for any port with the command line also sets DECnet on globally. In CompatiView you must set a global parameter and a port-specific parameter.*

#### Suggested for DECnet

Setting the parameters above should be adequate for most installations.

## WAN Interface Configuration

In order to use the WAN interface, you may want to set some physical parameters. Then set up the link and protocol parameters.

## Internal DS3 CSU/DSU Physical Communications Settings

#### Required for Dedicated Line Operation

No changes from the default values are required for standard operation over a DS3 line. The default values are listed in Chapter 3.

#### Suggested for Dedicated Line Operation

Changing to a different Line Build Out may be required. These parameters can only be set using the command line interface.

**TB:** Use **configure** and the **DS3 Interface WAN 0** section.

## PPP Configuration

This section covers the settings required for PPP (point-to-point) protocol operation of the DS3 WAN interface.

## Internal DS3 CSU/DSU Link Configuration

#### Required for Dedicated Line Operation

This is the only mode of operation supported via the built-in DS3 CSU/DSU.

- Set Dedicated connection
- Set PPP connection

**CV:** Use the Link Configuration: WAN Dialog Box.

**TB:** Use **configure** and then set the **Mode** and **ConnectMode** keywords in the **Link Config WAN 0** section.

#### Suggested for Dedicated Line Operation

Dedicated line operation generally does not require additional parameters for operation.

## IP Protocol

#### Required for IP

WAN interfaces which are set for PPP operation do not generally use an IP address. They are set to act as an “unnumbered interface.” In this mode of operation, there are no required settings.

#### Suggested for IP

These parameters help supply information about the segment that the interface is connected to. With this information, routing can take place.

- Set IP RIP 1, IP RIP 2, OSPF (Open Shortest Path First) or BGP (Border Gateway

Protocol)

- Set IP static routes

**CV:** Use the TCP/IP Routing: WAN Dialog Box to set RIP, and the IP Static Routing Dialog Box (under Global/IP Static Routes) to set static routes. OSPF and BGP can only be configured using text-based configuration.

**TB:** Use **configure** and set either the **RIPVersion** keyword or the **OSPFEnabled** keyword in the **IP WAN 0** section. Add static routes and a default router using the **edit config IP Static** command.

❖ **Note:** *Due to the complexity of BGP, configuration parameters for BGP are not given in this Quickstart. For help with BGP configuration parameters, and other configuration questions, refer to the Tech Support pages on the Compatible Systems Web site at:*

*<http://www.compatible.com/>.*

## IPX Protocol

### Required for IPX

WAN interfaces which are set for PPP operation do not generally use an IPX address. They are set to act as an “unnumbered interface.” In this mode of operation, there are no required settings.

## AppleTalk Protocol

### Required for AppleTalk

WAN interfaces which are set for PPP operation do not generally use an AppleTalk address. They are set to act as an “unnumbered interface.” In this mode of operation, there are no required settings.

## DECnet Protocol

### Required for DECnet

The router’s shipping configuration does not have DECnet turned on. In order to be used, DECnet must be turned on both globally and for a particular port.

- Set DECnet on (globally, and for a port)
- Set DECnet area
- Set DECnet node

**CV:** Use the DECnet Routing Dialog Box (under Global/DECnet Routing) and the DECnet: WAN Dialog Box.

**TB:** Use **configure** and set the **Mode** keyword in the **DECnet WAN 0** section. Use **configure** and set the **Enabled**, **Area**, and **Node** keywords in the **DECnet Global** section.

❖ **Note:** *Setting DECnet on for any port with the command line also sets DECnet on globally. In CompatiView you must set a global parameter and a port-specific parameter.*

## Frame Relay Configuration

This section covers the settings required for Frame Relay operation of the DS3 WAN interface.

## Internal DS3 CSU/DSU Link Configuration

### Required for Dedicated Line Operation

This is the only mode of operation supported via the built-in DS3 CSU/DSU.

- Set Dedicated connection

- Set Frame Relay connection

**CV:** Use the Link Configuration: WAN Dialog Box.

**TB:** Use **configure** and then set the **Mode** and **ConnectMode** keywords in the **Link Config WAN 0** section.

#### Suggested for Dedicated Line Operation

Dedicated line operation generally does not require additional parameters for operation.

## Frame Relay DLCI Mappings

If you are connecting to another Compatible Systems router, this information is not required for Frame Relay operation. Compatible Systems uses IARP (Inverse Address Resolution Protocol) to dynamically generate this information. To connect to other vendors' routers which do not support IARP, you must provide DLCI-to-protocol mapping information.

❖ **Note:** *Many Internet Service Providers (ISP's) do not support IARP as a default. If your WAN interface will be connected to an ISP via Frame Relay, check with your ISP technical staff on whether or not you must manually enter DLCI information.*

**CV:** Use the DLCI Mapping Database window.

**TB:** Use **configure** and set the **DLCI** keyword in the **Frame Relay WAN 0** section.

## IP Protocol

There are two ways to set up Frame Relay. One is to set the WAN interface as a “numbered interface.” This means that the interface (and thus the Frame Relay network) will have an IP address, subnet mask, etc. The other is to set it as an unnumbered interface and specify that the link is point-to-point Frame Relay and set the local DLCI. Unnumbered Frame Relay can only be configured using text-based configuration. Instructions are provided for both options.

#### Required for IP Numbered Interface

- IP numbered interface
- IP address
- IP subnet mask
- IP broadcast address

**CV:** Use the TCP/IP Routing: WAN Dialog Box.

**TB:** Use the **configure** command and the **Numbered**, **IPAddress**, **SubnetMask**, and **IPBroadcast** keywords in the **IP WAN 0** section.

#### Required for IP Unnumbered Interface

- IP unnumbered interface
- Point-to-Point Frame Relay
- Local DLCI

**TB:** Use the **configure** command and the **Numbered**, **PointToPointFrame** and **InterfaceDLCI** keywords in the **IP WAN 0** section.

#### Suggested for IP

These parameters help supply information about the segment that the interface is connected to. With this information, routing can take place.

- Set IP RIP 1, IP RIP 2, OSPF (Open Shortest Path First) or BGP (Border Gateway Protocol)
- IP static routes

**CV:** Use the TCP/IP Routing: WAN Dialog Box to set RIP, and the IP Static Routing Dialog

Box (under Global/IP Static Routes) to set static routes. OSPF and BGP can only be configured using text-based configuration.

**TB:** Use **configure** and set either the **RIPVersion** keyword or the **OSPFEEnabled** keyword in the **IP WAN 0** section. Add static routes and a default router using the **edit config IP Static** command.

❖ **Note:** *Due to the complexity of BGP, configuration parameters for BGP are not given in this Quickstart. For help with BGP configuration parameters, and other configuration questions, refer to the Tech Support pages on the Compatible Systems Web site at:*

*<http://www.compatible.com/>.*

## IPX Protocol

### Required for IPX

Frame Relay operation requires that the WAN interface be set as an IPX “numbered interface.” This means that the interface (and thus the Frame Relay network) must have an IPX network number.

- IPX numbered interface
- IPX network number

**CV:** Use the IPX Routing: WAN Dialog Box.

**TB:** Use **configure** and set the **Numbered** and **Net** keywords in the **IPX WAN 0** section.

### Suggested for IPX

The settings above are all that is generally required for IPX operation over Frame Relay.

## AppleTalk Protocol

### Required for AppleTalk

Frame Relay operation requires that the WAN interface be set as an AppleTalk “numbered interface.” This means that the interface (and thus the Frame Relay network) must have an AppleTalk network number and an AppleTalk node number.

- AppleTalk numbered interface
- AppleTalk network number
- AppleTalk node number
- AppleTalk zone name

**CV:** Use the AppleTalk Routing: WAN Dialog Box.

**TB:** Use **configure** and set the **Numbered**, **NetLower**, and **DefZone** keywords in the **AppleTalk WAN 0** section.

### Suggested for AppleTalk

The settings above are all that is generally required for AppleTalk operation over Frame Relay.

## DECnet Protocol

### Required for DECnet

In order to be used, DECnet must be turned on both globally and for a particular port.

WAN interfaces which are set for Frame Relay operation do not need any additional parameters set in order to function.

- Set DECnet on (globally, and for this port)

**CV:** Use the DECnet Routing Dialog Box (under Global/DECnet Routing) and the DECnet: WAN Dialog Box.

**TB:** Use **configure** and set the **Mode** keyword in the **DECnet WAN 0** section.

❖ **Note:** *Setting DECnet on for any port with the command line also sets DECnet on globally. In CompatiView you must set a global parameter and a port-specific parameter.*

## SMDS Configuration

This section covers the settings required for SMDS (Switched Multi-megabit Data Service) operation of the DS3 WAN interface (IP only). SMDS is a connectionless, packet-switched service that offers LAN-to-LAN connectivity across a wide area at up to 1.544 Mbps. SMDS addresses and other parameters can only be set using the command line interface.

❖ **Note:** *The IP protocol settings and the physical communication settings are the same as they would be for Frame Relay operation. The only parameters which should be set differently for SMDS are the Link Configuration and the SMDS addressing section.*

### Link Configuration

SMDS is presently supported in the DS3-Quad 10/100 RIOP only via synchronous dedicated line operation.

- Set Dedicated connection
- Set SMDS connection

**TB:** Use **configure** to set the **Mode** and **ConnectMode** keywords in the **Link Config WAN 0** section.

#### Suggested for Dedicated/Leased Line Operation

Dedicated line operation generally does not require additional parameters for operation.

### SMDS Addressing

Many of these parameters will be given to you by your service provider.

**TB:** Use **configure** and set the **StationAddress**, **IPMulticast** and **PollingFrequency** keywords in the **SMDS WAN 0** section.

## Saving a Configuration File to Flash ROM

Once a configuration is complete, you can save it to the router's Flash ROM. Until saved, all changes are made in a separate buffer and the actual router interfaces continue to run as before the changes were made.

**CV:** Use the Save to/Device option from the File menu.

**TB:** Use the **save** command.

---

# Chapter 3 - Shipping Defaults

## Ethernet Interfaces

### IP Routing Defaults

- Off, all interfaces

### IP Bridging Defaults

- On, all interfaces
- Address: 198.41.12.1
- Subnet Mask: 255.255.255.0
- Broadcast Address: 198.41.12.255
- IP RIP off

### IPX Routing Defaults

- 802.3 on, autoseeding, all interfaces
- 802.2 on, autoseeding, all interfaces
- Type II on, nonseeding
- 802.2 SNAP on, nonseeding

### IPX Bridging Defaults

- Off, all interfaces

### AppleTalk Routing Defaults

- Phase I off, all interfaces
- Phase II on, autoseeding, all interfaces

### AppleTalk Bridging Defaults

- Off, all interfaces

### DECnet Defaults

- Off, all interfaces

## WAN Interface

### IP Defaults

- On
- Unnumbered interface
- RIP off
- Van Jacobson compression off

### IPX Defaults

- On
- Unnumbered interface

### AppleTalk Defaults

- On
- Unnumbered interface

### DECnet Defaults

- Off

### DS3 CSU/DSU Defaults

- PPP
- 16 bit CRC

# Chapter 4 - LED Patterns

Some of the LEDs on the front of the VSR multigigabit switching router serve dual functions. In addition to indicating certain router-wide operating conditions, they can also display port-specific information.

❖ **Note:** *Any continuous flashing pattern not noted in this chapter may be caused by a hardware failure. Please call Compatible Systems Technical Support if your router shows a hardware failure.*

## Router LED Patterns

The following LEDs and light patterns provide information about the VSR's physical state and operating conditions.

### Over Temp

The router is above the proper operating temperature. The filter needs changing. See the appropriate VSR chassis section of the manual for instructions.

### Sys Ready

The router booted properly without detecting any failures.

### General Indicators

Ethernet Lights	DS3 Lights	Indication
5 flashing	1 flashing	Router stacks starting up.
3&4 flashing	2&3 flashing	No OS loaded. Running from ROM.
1&4 flashing	2&5 flashing	Erasing OS in Flash ROM.
5 flashing	1,2&3 flashing	Erasing config in Flash ROM.
1 - 5 scanning	5 - 1 scanning	Flash ROM erase due to switch setting five or six is complete. Set switch to zero and cycle power.



---

## DS3-Quad 10/100 RIOP LED Patterns

The following LEDs and light patterns provide information about the DS3-Quad 10/100 RIOP interfaces.

### **Ethernet Traffic Indicators**

Scan from 1 to 3: Ethernet transmit packet

Scan from 5 to 3: Ethernet receive packet

### **DS3 Indicators**

Scan from 1 to 3: WAN transmit packet

Scan from 5 to 3: WAN receive packet

### **Ethernet Connection Indicators**

Link: The Link light indicates that there is a good connection to the hub.

Activity: The Activity light indicates that there is activity across the link.

100: The 100 light indicates that the interface is operating at 100 Mbps.

### **DS3 Connection Indicators**

TX: WAN transmit packet

RX: WAN receive packet

Link: The Link light indicates that the interface is receiving signal from the upstream terminal.