



# Cisco Multiband Diversity Omnidirectional Ceiling-Mount Antenna (AIR-ANTM4050V-R)

---

This document outlines the specifications and describes the AIR-ANTM4050V-R multiband diversity omnidirectional ceiling-mount antenna and contains the following sections:

- [Cisco 90-Day Limited Hardware Warranty Terms, page 1](#)
- [Overview, page 3](#)
- [Technical Specifications, page 3](#)
- [System Requirements, page 7](#)
- [Installation Notes, page 8](#)
- [Safety Instructions, page 9](#)
- [Installation Instructions, page 10](#)
- [Obtaining Documentation, page 12](#)
- [Documentation Feedback, page 13](#)
- [Cisco Product Security Overview, page 14](#)
- [Obtaining Technical Assistance, page 14](#)
- [Obtaining Additional Publications and Information, page 16](#)

## Cisco 90-Day Limited Hardware Warranty Terms

There are special terms applicable to your hardware warranty and various services that you can use during the warranty period. Your formal Warranty Statement, including the warranties and license agreements applicable to Cisco software, is available on Cisco.com. Follow these steps to access and download the *Cisco Information Packet* and your warranty and license agreements from Cisco.com.

1. Launch your browser, and go to this URL:

[http://www.cisco.com/univercd/cc/td/doc/es\\_inpk/cetrans.htm](http://www.cisco.com/univercd/cc/td/doc/es_inpk/cetrans.htm)

The Warranties and License Agreements page appears.



---

Corporate Headquarters:  
Cisco Systems, Inc., 170 West Tasman Drive, San Jose, CA 95134-1706 USA

© 2005 Cisco Systems, Inc. All rights reserved.

2. To read the *Cisco Information Packet*, follow these steps:
  - a. Click the **Information Packet Number** field, and make sure that the part number 78-5235-03A0 is highlighted.
  - b. Select the language in which you would like to read the document.
  - c. Click **Go**.

The Cisco Limited Warranty and Software License page from the Information Packet appears.

- d. Read the document online, or click the **PDF** icon to download and print the document in Adobe Portable Document Format (PDF).



---

**Note** You must have Adobe Acrobat Reader to view and print PDF files. You can download the reader from Adobe's website: <http://www.adobe.com>

---

3. To read translated and localized warranty information about your product, follow these steps:
  - a. Enter this part number in the Warranty Document Number field:  
78-5236-01C0
  - b. Select the language in which you would like to read the document.
  - c. Click **Go**.

The Cisco warranty page appears.

- d. Review the document online, or click the **PDF** icon to download and print the document in Adobe Portable Document Format (PDF).

You can also contact the Cisco service and support website for assistance:

[http://www.cisco.com/public/Support\\_root.shtml](http://www.cisco.com/public/Support_root.shtml).

#### Duration of Hardware Warranty

Ninety (90) days.

#### Replacement, Repair, or Refund Policy for Hardware

Cisco or its service center will use commercially reasonable efforts to ship a replacement part within ten (10) working days after receipt of a Return Materials Authorization (RMA) request. Actual delivery times can vary, depending on the customer location.

Cisco reserves the right to refund the purchase price as its exclusive warranty remedy.

#### To Receive a Return Materials Authorization (RMA) Number

Contact the company from whom you purchased the product. If you purchased the product directly from Cisco, contact your Cisco Sales and Service Representative.

Complete the information below, and keep it for reference:

Company product purchased from	
Company telephone number	
Product model number	
Product serial number	
Maintenance contract number	

# Overview

The AIR-ANTM4050V-R antenna operates in the 2.4- and 5-GHz bands, and is designed for use with spatial-diversity access point (AP) systems. The AIR-ANTM4050V-R antenna is compatible with Cisco 802.11a/b/g radio products using a reverse-polarity threaded Neill-Concelman (RP-TNC) connector.

Figure 1 and Figure 2 show the front and rear panels of the AIR-ANTM4050V-R antenna.

**Figure 1** Cisco AIR-ANTM4050V-R Antenna (Front Panel)

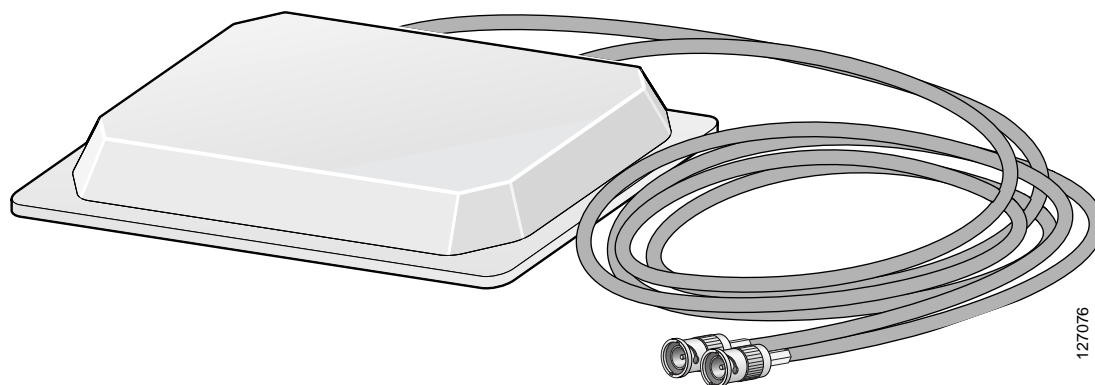

**Figure 2** Cisco AIR-ANTM4050V-R Antenna Back Panel

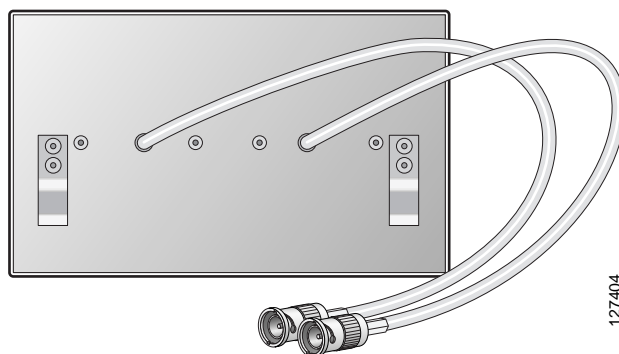

## Technical Specifications

The following table lists the technical specifications for the AIR-ANTM4050V-R antenna.

Antenna type	Omnidirectional patch
Operating frequency range	2400 to 2500 MHz and 4900 to 5990 MHz
Maximum VSWR <sup>1</sup> bandwidth	2.0:1
Peak gain	<ul style="list-style-type: none"> <li>2.4-GHz: 4 dBi</li> <li>5-GHz: 5 dBi</li> </ul>
Polarization	Linear (vertical) (2x)

<b>Azimuth plane beamwidth</b>	Omnidirectional
<b>Elevation plane 3 dB beamwidth (H-plane)</b>	Omnidirectional
<b>Elevation plane 3 dB beamwidth (E-plane)</b>	60 degrees
<b>Coaxial cable</b>	3 ft (0.9 m) plenum rated
<b>Dimensions</b>	6.2 x 3.6 x 0.9 in. (158 x 91 x 23 mm)
<b>Weight</b>	0.5 lb (0.23 kg)
<b>Connector type</b>	RP-TNC (2x)
<b>Enclosure</b>	Acrylic/PVC
<b>Environment</b>	Indoor only
<b>Mounting</b>	Ceiling grid, suspended tile

1. VSWR = voltage standing wave ratio

Figure 3 shows the H-plane radiation pattern at 2.4- to 2.5-GHz for the AIR-ANTM4050V-R antenna.

**Figure 3** *H-Plane Pattern at 2.4- to 2.5-GHz*

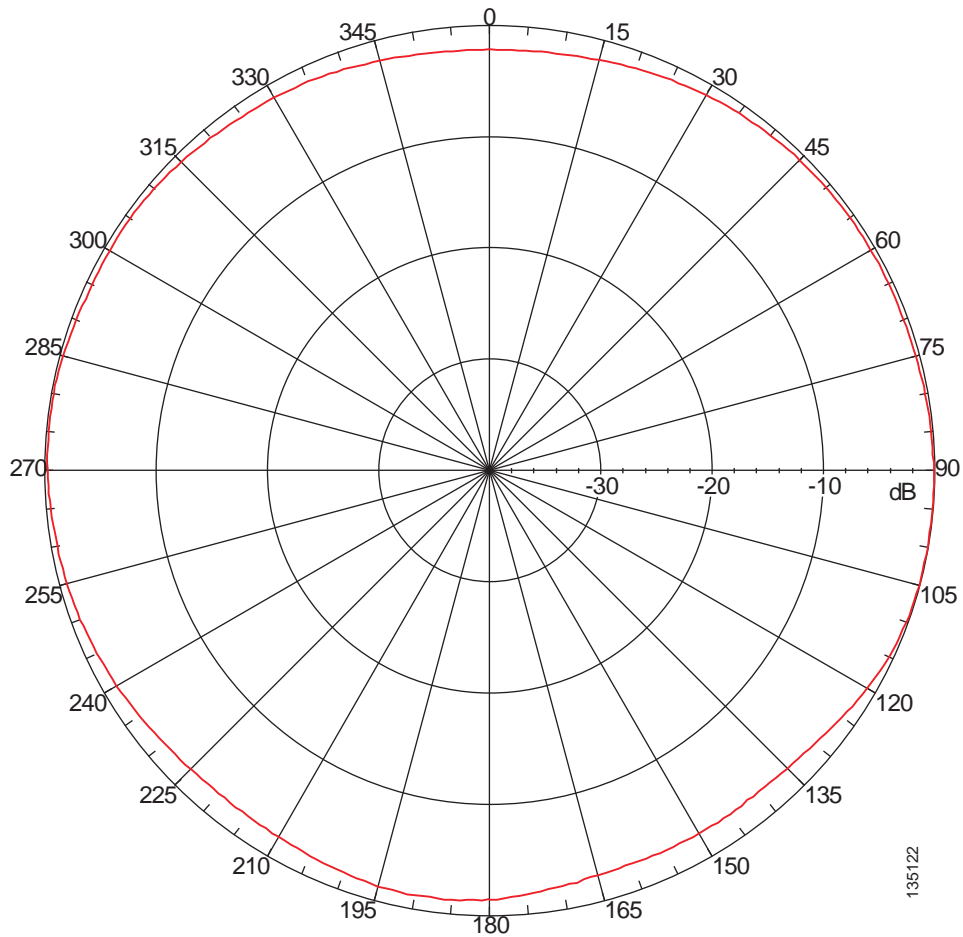

Figure 4 shows the E-plane radiation pattern at 2.4- to 2.5-GHz for the AIR-ANTM4050V-R antenna.

**Figure 4** *E-Plane Pattern at 2.4- to 2.5-GHz*

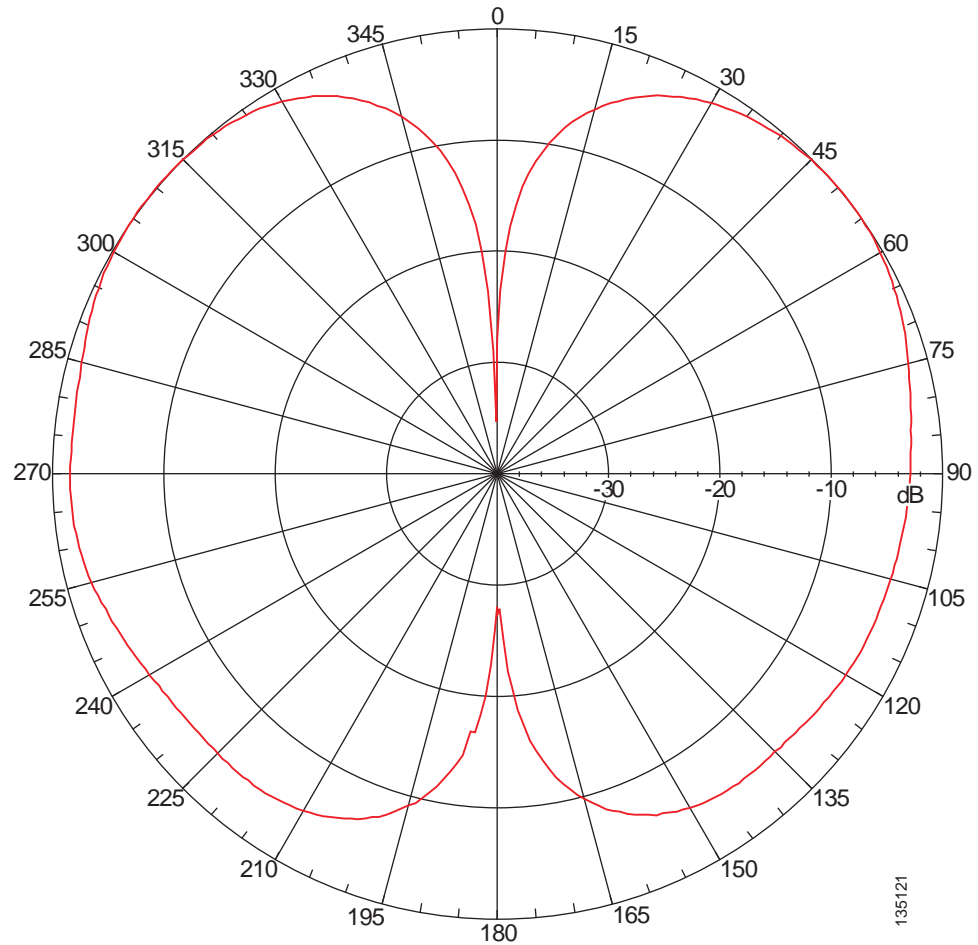

Figure 5 shows the H-plane radiation pattern at 4.9- to 5.99-GHz for the AIR-ANTM4050V-R antenna.

Figure 5 H-Plane Pattern at 4.9- to 5.99-GHz

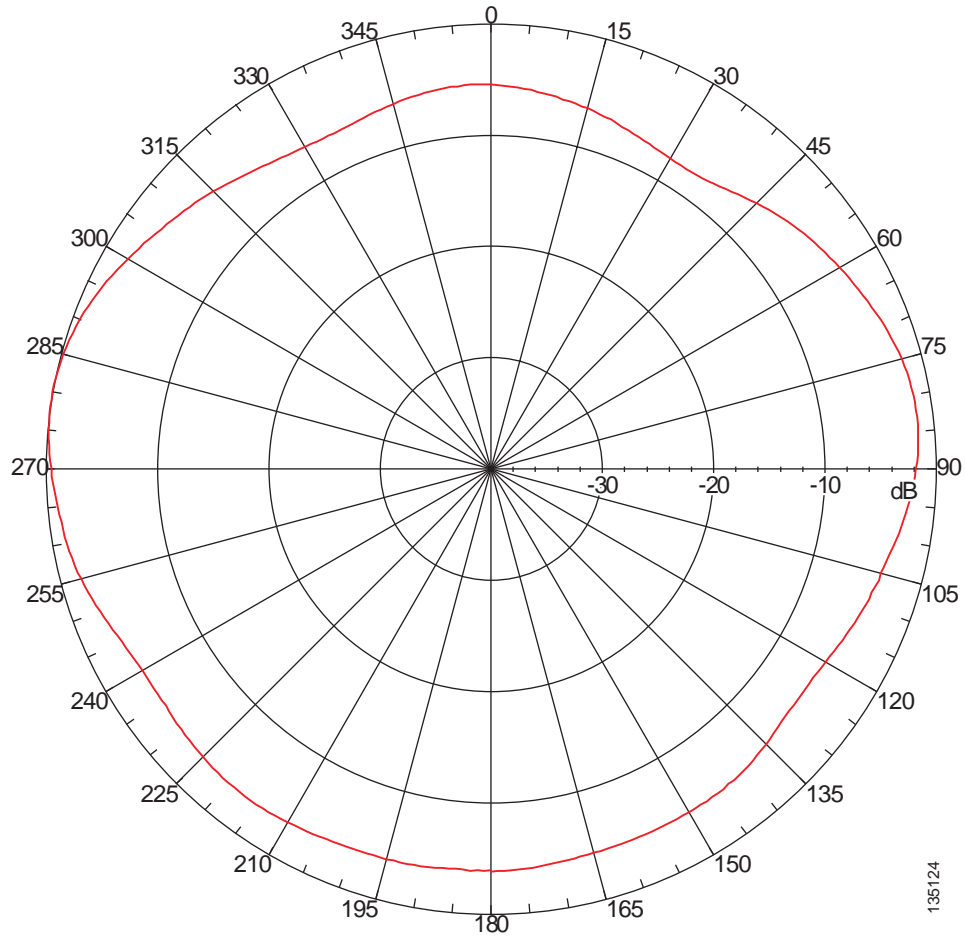
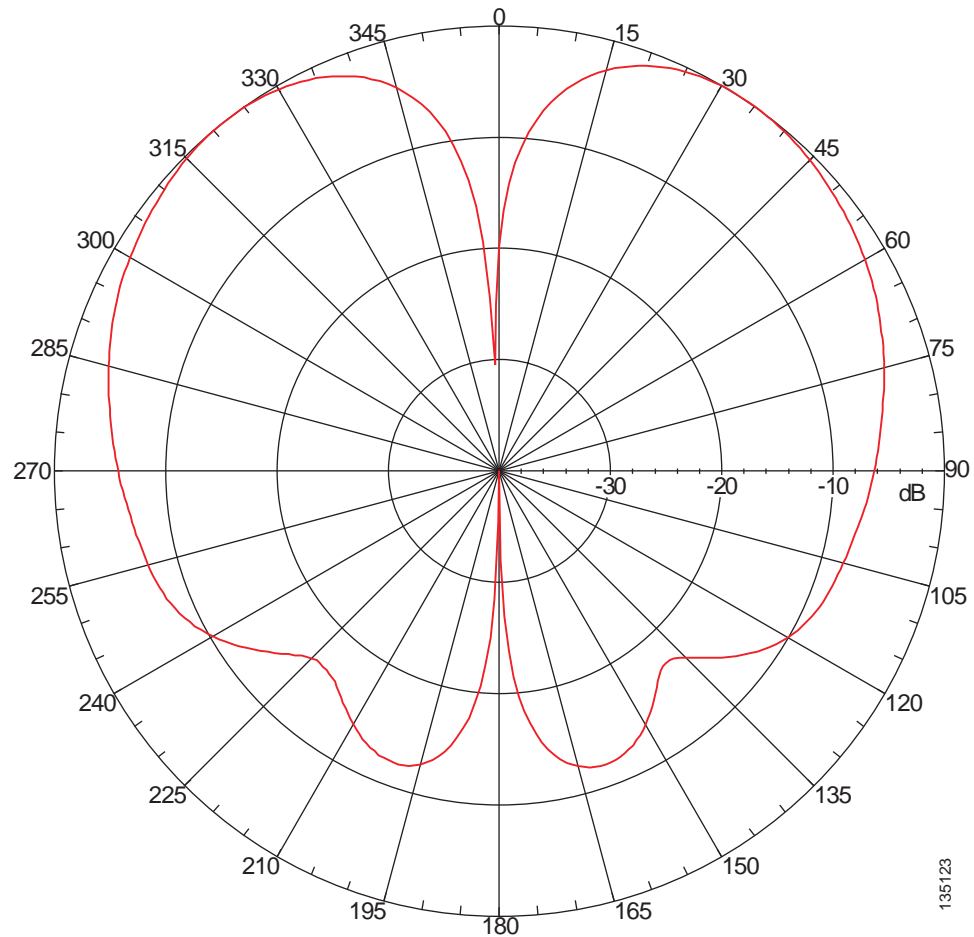

Figure 6 shows the E-plane radiation pattern at 4.9- to 5.99-GHz for the AIR-ANTM4050V-R antenna.

Figure 6 E-Plane Pattern at 4.9- to 5.99-GHz



## System Requirements

The AIR-ANTM4050V-R antenna requires a Cisco 802.11a/b/g radio product that uses a RP-TNC connector.

# Installation Notes

This antenna is designed to be mounted indoors on a suspended ceiling track having either flush or recessed mounted ceiling tiles.

Because antennas transmit and receive radio signals, they are susceptible to radio frequency (RF) obstructions and common sources of interference that can reduce throughput and range of the device to which they are connected. Follow these guidelines to ensure the best possible performance:

- Mount the antenna to use its propagation characteristics. For best results, mount the antenna horizontally at ceiling level near the center of the coverage area.



---

**Note** The antenna must be mounted horizontally in order to maximize its omnidirectional propagation characteristics. Mounting it vertically may noticeably decrease the antenna range and overall performance.

---

- Mount the antenna where the wireless devices would be within sight. Avoid mounting the antenna next to a column or vertical support that could create a shadow zone and reduce the coverage area.
- Keep the antenna away from metal obstructions such as heating and air-conditioning ducts, large ceiling trusses, building superstructures, and major power cabling runs. If necessary, use a rigid conduit to lower the antenna away from these obstructions.
- The density of the materials used in a building's construction determines the number of walls the signal must pass through and still maintain adequate coverage. Consider the following before choosing the location to install your antenna:
  - Paper and vinyl walls have very little effect on signal penetration.
  - Solid and precast concrete walls limit signal penetration to one or two walls without degrading coverage.
  - Concrete and wood block walls limit signal penetration to three or four walls.
  - A signal can penetrate five or six walls constructed of drywall or wood.
  - A thick metal wall causes signals to reflect off, causing poor penetration.
- Install the antenna away from microwave ovens and 2-GHz cordless phones. These products can cause signal interference because they operate in the same frequency range as the device to which your antenna is connected.
- To extend the coaxial cable included with your antenna, we recommend a low-loss or ultra-low-loss coaxial cable for installation flexibility without a significant loss in range. The following table lists transmission loss information about low-loss and ultra-low-loss extension coaxial cables available from Cisco.

Cisco Product Number	Cable Length	Transmission Loss
AIR-CAB020LL-R	20 ft (6 m)	<ul style="list-style-type: none"> <li>• 2.4-GHz: 1.3 dBi</li> <li>• 5-GHz: 2.5 dBi</li> </ul>
AIR-CAB050LL-R	50 ft (15 m)	<ul style="list-style-type: none"> <li>• 2.4-GHz: 3.3 dBi</li> <li>• 5-GHz: 5.75 dBi</li> </ul>



Cisco Product Number	Cable Length	Transmission Loss
AIR-CAB100ULL-R	100 ft (30 m)	<ul style="list-style-type: none"> <li>• 2.4-GHz: 4.4 dBi</li> <li>• 5-GHz: 7.25 dBi</li> </ul>
AIR-CAB150ULL-R	150 ft (46 m)	<ul style="list-style-type: none"> <li>• 2.4-GHz: 6.6 dBi</li> <li>• 5-GHz: 11 dBi</li> </ul>

## Safety Instructions

Follow these safety instructions when installing your antenna.



Warning

**In order to comply with FCC radio frequency (RF) exposure limits, antennas should be located at a minimum of 7.9 inches (20 cm) or more from the body of all persons.** Statement 332

- Plan your installation procedure carefully and completely before you begin.
- If you are installing an antenna for the first time, for your own safety as well as that of others, seek *professional assistance*. Consult your dealer, who can explain which mounting method to use for the location where you intend to install the antenna.
- Choose your installation site with safety as well as performance in mind. Remember that electric power cables and telephone lines look alike. For your safety, assume that any line is an electric power line until determined otherwise.
- Call your local power company or building maintenance organization if you are unsure about cables close to your mounting location.
- When installing your antenna, *do not* use a metal ladder. *Do* dress properly: shoes with rubber soles and heels, rubber gloves, and a long-sleeved shirt or jacket.
- If an accident or emergency occurs with the power lines, call for qualified emergency help immediately.

# Installation Instructions

The following sections contain procedures for installing the antenna on a suspended ceiling.

## Mounting on Suspended Ceilings with Flush Mounted Tiles

The antenna is configured to mount to a suspended ceiling track with flush mounted tiles. Suspended ceiling mounting clips are provided on the rear panel of the antenna. (See [Figure 7](#).)

**Figure 7** *Suspended Ceiling with Flush Mounted Tiles*

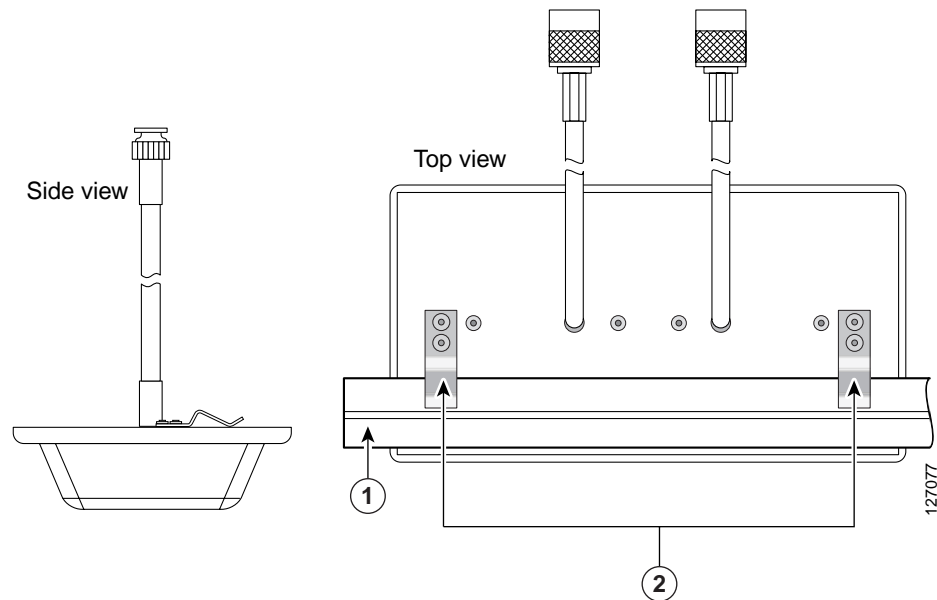

1	Ceiling track	2	Suspended ceiling mounting clips
---	---------------	---	----------------------------------

After you have selected a suitable location, follow these steps to mount the antenna:

- 
- Step 1** Make two small slots in the ceiling tile for the cables to pass through.
  - Step 2** Line up the antenna mounting clips with the ceiling track.
  - Step 3** Grasp the antenna with one hand and the track with the other while gently pushing the antenna until the clips are securely attached to the track.
  - Step 4** Route the antenna cables into the space above the ceiling grid and connect them to the device or extender cables.
  - Step 5** Replace the ceiling tiles.



**Note** You may have to trim some material from one of the tiles to accommodate the antenna cables.

---

## Mounting on Suspended Ceilings with Recessed Tiles

The antenna can be mounted to a suspended ceiling with recessed tiles by using the provided plastic recessed ceiling mounting clip adapter. (See [Figure 8](#).)

**Figure 8** Recessed Ceiling Mounting Clip Adapter

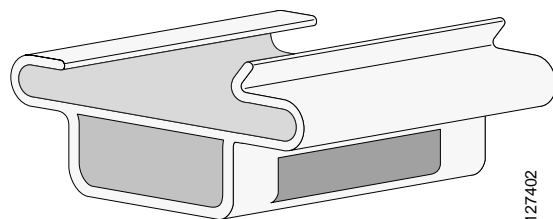

After you have selected a suitable location, follow these steps to mount your antenna:

- 
- Step 1** Remove two ceiling tiles on either side of the ceiling track.
  - Step 2** Mark a center point on the ceiling track at the location where you intend to mount the antenna.
  - Step 3** Mark a point 2.5 in. (63 mm) from either side of the center point. The distance between these two points should be about 6 in. (152 mm).
  - Step 4** Examine the adapter clips. One side has an elongated opening and a tab.
  - Step 5** Follow these steps to install a recessed ceiling mounting clip adapter at each point:
    - a. Insert the side without the opening and tab onto the ceiling track.
    - b. Push the tab to lock the other end onto the ceiling track.
    - c. Install the second adapter the same way you installed the first.
    - d. Make sure that the adapters are about 6 in. (152 mm) apart and the elongated openings are on the same side of the ceiling track as shown in [Figure 9](#).

**Figure 9** Ceiling Mounting Clip Adapters

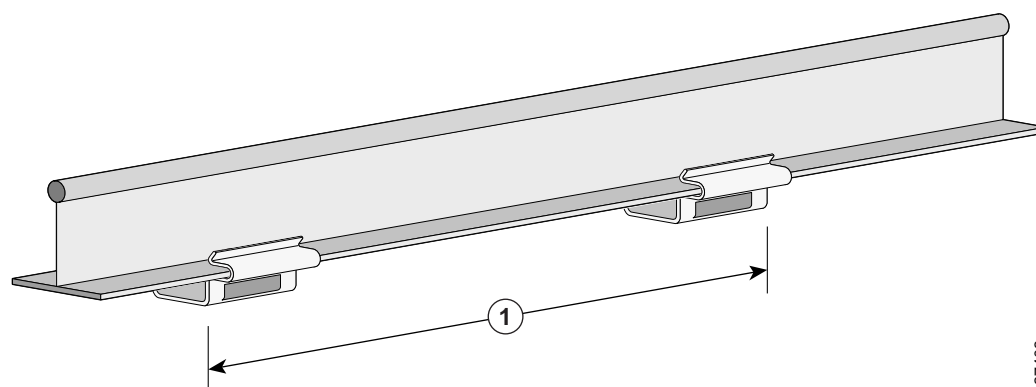

<b>1</b>	Distance between mounting clip adapters (about 6 in. [152 mm] apart)		
----------	----------------------------------------------------------------------	--	--

- Step 6** Grasp the antenna with one hand and the track with the other while inserting the antenna's mounting clips into the ceiling mounting clip adapter until they can go no further, as shown in [Figure 10](#).

*Figure 10 Inserting the Mounting Clips into the Mounting Clip Adapter*

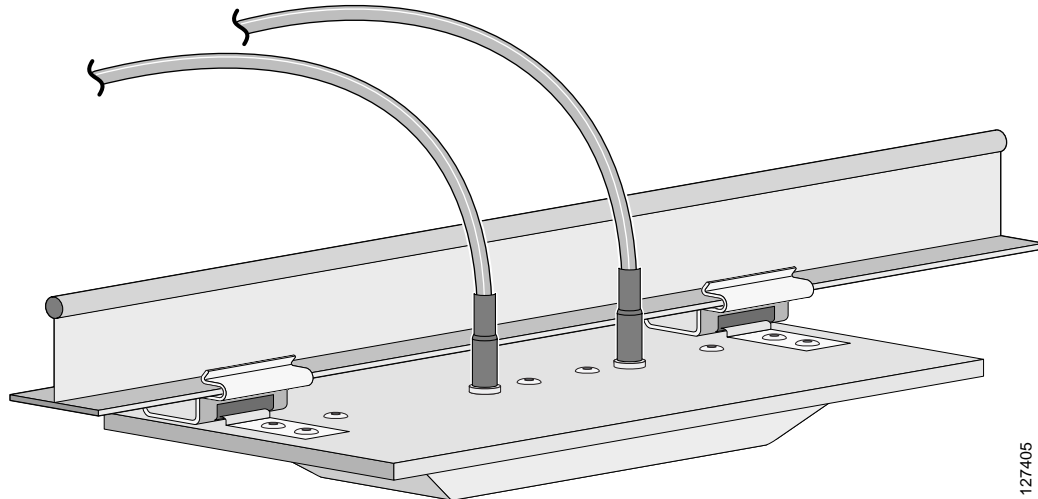

- Step 7** Route the antenna cables into the space above the ceiling grid and connect them to the device or extender cables.



**Note** You may have to trim some material from one of the tiles to accommodate the antenna cables.

- Step 8** Replace the ceiling tiles.

## Obtaining Documentation

Cisco documentation and additional literature are available on Cisco.com. Cisco also provides several ways to obtain technical assistance and other technical resources. These sections explain how to obtain technical information from Cisco Systems.

### Cisco.com

You can access the most current Cisco documentation at this URL:

<http://www.cisco.com/univercd/home/home.htm>

You can access the Cisco website at this URL:

<http://www.cisco.com>

You can access international Cisco websites at this URL:

[http://www.cisco.com/public/countries\\_languages.shtml](http://www.cisco.com/public/countries_languages.shtml)

## Documentation DVD

Cisco documentation and additional literature are available in a Documentation DVD package, which may have shipped with your product. The Documentation DVD is updated regularly and may be more current than printed documentation. The Documentation DVD package is available as a single unit.

Registered Cisco.com users (Cisco direct customers) can order a Cisco Documentation DVD (product number DOC-DOCDVD=) from the Ordering tool or Cisco Marketplace.

Cisco Ordering tool:

<http://www.cisco.com/en/US/partner/ordering/>

Cisco Marketplace:

<http://www.cisco.com/go/marketplace/>

## Ordering Documentation

You can find instructions for ordering documentation at this URL:

[http://www.cisco.com/univercd/cc/td/doc/es\\_inpk/pdi.htm](http://www.cisco.com/univercd/cc/td/doc/es_inpk/pdi.htm)

You can order Cisco documentation in these ways:

- Registered Cisco.com users (Cisco direct customers) can order Cisco product documentation from the Ordering tool:  
<http://www.cisco.com/en/US/partner/ordering/>
- Nonregistered Cisco.com users can order documentation through a local account representative by calling Cisco Systems Corporate Headquarters (California, USA) at 408 526-7208 or, elsewhere in North America, by calling 1 800 553-NETS (6387).

## Documentation Feedback

You can send comments about technical documentation to [bug-doc@cisco.com](mailto:bug-doc@cisco.com).

You can submit comments by using the response card (if present) behind the front cover of your document or by writing to the following address:

Cisco Systems  
Attn: Customer Document Ordering  
170 West Tasman Drive  
San Jose, CA 95134-9883

We appreciate your comments.

# Cisco Product Security Overview

Cisco provides a free online Security Vulnerability Policy portal at this URL:

[http://www.cisco.com/en/US/products/products\\_security\\_vulnerability\\_policy.html](http://www.cisco.com/en/US/products/products_security_vulnerability_policy.html)

From this site, you can perform these tasks:

- Report security vulnerabilities in Cisco products.
- Obtain assistance with security incidents that involve Cisco products.
- Register to receive security information from Cisco.

A current list of security advisories and notices for Cisco products is available at this URL:

<http://www.cisco.com/go/psirt>

If you prefer to see advisories and notices as they are updated in real time, you can access a Product Security Incident Response Team Really Simple Syndication (PSIRT RSS) feed from this URL:

[http://www.cisco.com/en/US/products/products\\_psirt\\_rss\\_feed.html](http://www.cisco.com/en/US/products/products_psirt_rss_feed.html)

## Reporting Security Problems in Cisco Products

Cisco is committed to delivering secure products. We test our products internally before we release them, and we strive to correct all vulnerabilities quickly. If you think that you might have identified a vulnerability in a Cisco product, contact PSIRT:

- Emergencies—[security-alert@cisco.com](mailto:security-alert@cisco.com)
- Nonemergencies—[psirt@cisco.com](mailto:psirt@cisco.com)



Tip

We encourage you to use Pretty Good Privacy (PGP) or a compatible product to encrypt any sensitive information that you send to Cisco. PSIRT can work from encrypted information that is compatible with PGP versions 2.x through 8.x.

Never use a revoked or an expired encryption key. The correct public key to use in your correspondence with PSIRT is the one that has the most recent creation date in this public key server list:

<http://pgp.mit.edu:11371/pks/lookup?search=psirt%40cisco.com&op=index&exact=on>

In an emergency, you can also reach PSIRT by telephone:

- 1 877 228-7302
- 1 408 525-6532

## Obtaining Technical Assistance

For all customers, partners, resellers, and distributors who hold valid Cisco service contracts, Cisco Technical Support provides 24-hour-a-day, award-winning technical assistance. The Cisco Technical Support Website on Cisco.com features extensive online support resources. In addition, Cisco Technical Assistance Center (TAC) engineers provide telephone support. If you do not hold a valid Cisco service contract, contact your reseller.

## Cisco Technical Support Website

The Cisco Technical Support Website provides online documents and tools for troubleshooting and resolving technical issues with Cisco products and technologies. The website is available 24 hours a day, 365 days a year, at this URL:

<http://www.cisco.com/techsupport>

Access to all tools on the Cisco Technical Support Website requires a Cisco.com user ID and password. If you have a valid service contract but do not have a user ID or password, you can register at this URL:

<http://tools.cisco.com/RPF/register/register.do>



### Note

Use the Cisco Product Identification (CPI) tool to locate your product serial number before submitting a web or phone request for service. You can access the CPI tool from the Cisco Technical Support Website by clicking the **Tools & Resources** link under Documentation & Tools. Choose **Cisco Product Identification Tool** from the Alphabetical Index drop-down list, or click the **Cisco Product Identification Tool** link under Alerts & RMAs. The CPI tool offers three search options: by product ID or model name; by tree view; or for certain products, by copying and pasting **show** command output. Search results show an illustration of your product with the serial number label location highlighted. Locate the serial number label on your product and record the information before placing a service call.

## Submitting a Service Request

Using the online TAC Service Request Tool is the fastest way to open S3 and S4 service requests. (S3 and S4 service requests are those in which your network is minimally impaired or for which you require product information.) After you describe your situation, the TAC Service Request Tool provides recommended solutions. If your issue is not resolved using the recommended resources, your service request is assigned to a Cisco TAC engineer. The TAC Service Request Tool is located at this URL:

<http://www.cisco.com/techsupport/servicerequest>

For S1 or S2 service requests or if you do not have Internet access, contact the Cisco TAC by telephone. (S1 or S2 service requests are those in which your production network is down or severely degraded.) Cisco TAC engineers are assigned immediately to S1 and S2 service requests to help keep your business operations running smoothly.

To open a service request by telephone, use one of the following numbers:

Asia-Pacific: +61 2 8446 7411 (Australia: 1 800 805 227)

EMEA: +32 2 704 55 55

USA: 1 800 553-2447

For a complete list of Cisco TAC contacts, go to this URL:

<http://www.cisco.com/techsupport/contacts>

## Definitions of Service Request Severity

To ensure that all service requests are reported in a standard format, Cisco has established severity definitions.

Severity 1 (S1)—Your network is “down,” or there is a critical impact to your business operations. You and Cisco will commit all necessary resources around the clock to resolve the situation.

Severity 2 (S2)—Operation of an existing network is severely degraded, or significant aspects of your business operation are negatively affected by inadequate performance of Cisco products. You and Cisco will commit full-time resources during normal business hours to resolve the situation.

Severity 3 (S3)—Operational performance of your network is impaired, but most business operations remain functional. You and Cisco will commit resources during normal business hours to restore service to satisfactory levels.

Severity 4 (S4)—You require information or assistance with Cisco product capabilities, installation, or configuration. There is little or no effect on your business operations.

## Obtaining Additional Publications and Information

Information about Cisco products, technologies, and network solutions is available from various online and printed sources.

- Cisco Marketplace provides a variety of Cisco books, reference guides, and logo merchandise. Visit Cisco Marketplace, the company store, at this URL:

<http://www.cisco.com/go/marketplace/>

- *Cisco Press* publishes a wide range of general networking, training and certification titles. Both new and experienced users will benefit from these publications. For current Cisco Press titles and other information, go to Cisco Press at this URL:

<http://www.ciscopress.com>

- *Packet* magazine is the Cisco Systems technical user magazine for maximizing Internet and networking investments. Each quarter, Packet delivers coverage of the latest industry trends, technology breakthroughs, and Cisco products and solutions, as well as network deployment and troubleshooting tips, configuration examples, customer case studies, certification and training information, and links to scores of in-depth online resources. You can access Packet magazine at this URL:

<http://www.cisco.com/packet>

- *iQ Magazine* is the quarterly publication from Cisco Systems designed to help growing companies learn how they can use technology to increase revenue, streamline their business, and expand services. The publication identifies the challenges facing these companies and the technologies to help solve them, using real-world case studies and business strategies to help readers make sound technology investment decisions. You can access iQ Magazine at this URL:

<http://www.cisco.com/go/iqmagazine>



- *Internet Protocol Journal* is a quarterly journal published by Cisco Systems for engineering professionals involved in designing, developing, and operating public and private internets and intranets. You can access the Internet Protocol Journal at this URL:

<http://www.cisco.com/ipj>

- World-class networking training is available from Cisco. You can view current offerings at this URL:

<http://www.cisco.com/en/US/learning/index.html>

---

CCSP, CCVP, the Cisco Square Bridge logo, Follow Me Browsing, and StackWise are trademarks of Cisco Systems, Inc.; Changing the Way We Work, Live, Play, and Learn, and iQuick Study are service marks of Cisco Systems, Inc.; and Access Registrar, Aironet, ASIST, BPX, Catalyst, CCDA, CCDP, CCIE, CCIP, CCNA, CCNP, Cisco, the Cisco Certified Internetwork Expert logo, Cisco IOS, Cisco Press, Cisco Systems, Cisco Systems Capital, the Cisco Systems logo, Cisco Unity, Empowering the Internet Generation, Enterprise/Solver, EtherChannel, EtherFast, EtherSwitch, Fast Step, FormShare, GigaDrive, GigaStack, HomeLink, Internet Quotient, IOS, IP/TV, iQ Expertise, the iQ logo, iQ Net Readiness Scorecard, LightStream, Linksys, MeetingPlace, MGX, the Networkers logo, Networking Academy, Network Registrar, *Packet*, PIX, Post-Routing, Pre-Routing, ProConnect, RateMUX, ScriptShare, SlideCast, SMARTnet, StrataView Plus, TeleRouter, The Fastest Way to Increase Your Internet Quotient, and TransPath are registered trademarks of Cisco Systems, Inc. and/or its affiliates in the United States and certain other countries.

All other trademarks mentioned in this document or Website are the property of their respective owners. The use of the word partner does not imply a partnership relationship between Cisco and any other company. (0502R)

Copyright © 2005 Cisco Systems, Inc. All rights reserved.

