

AUTOMATIC GAS WATER BOILER

ME10-GN ME15-GN

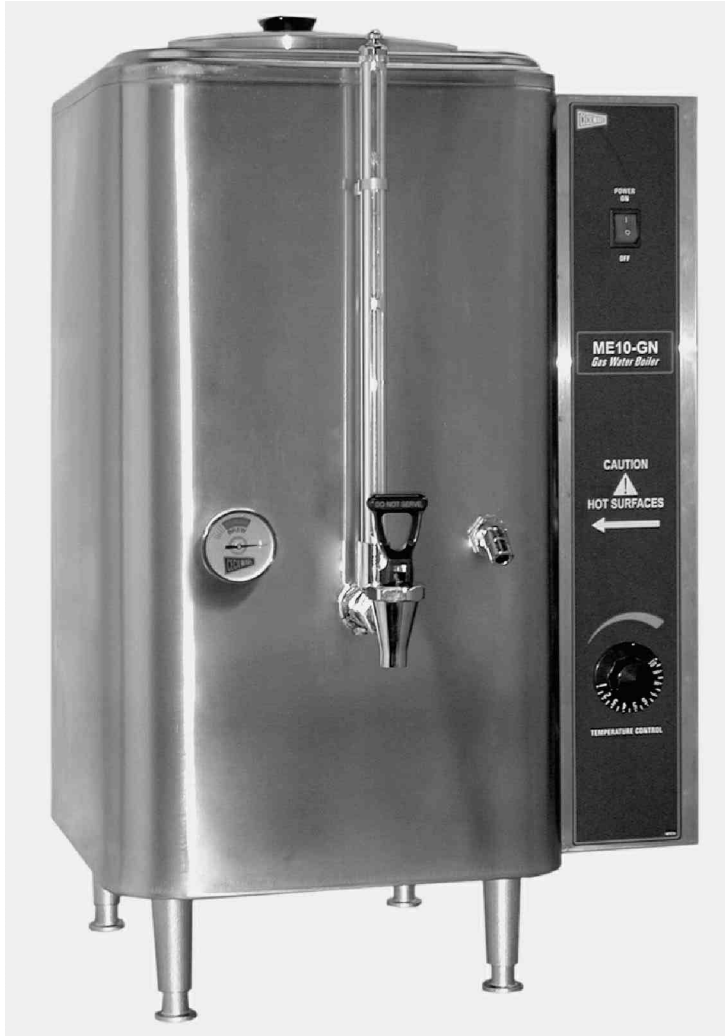

**18 Gauge Type 304L
Stainless Steel
construction to resist
corrosion.
Solid State water level
control for automatic
refill**

CONTENTS

**Specifications
Start up Instructions
Trouble Shooting Guide
Parts List
Wiring Diagram**

Cecilware sells value... Worldwide

Cecilware Corporation

43-05 20th Avenue, Long Island City, NY 11105-1295

718-932-1414 Fax: 718-932-7860

800-935-2211 E-Mail: customer.service@cecilware.com www.cecilware.com



Operation Manual
NQ24A 12-2006

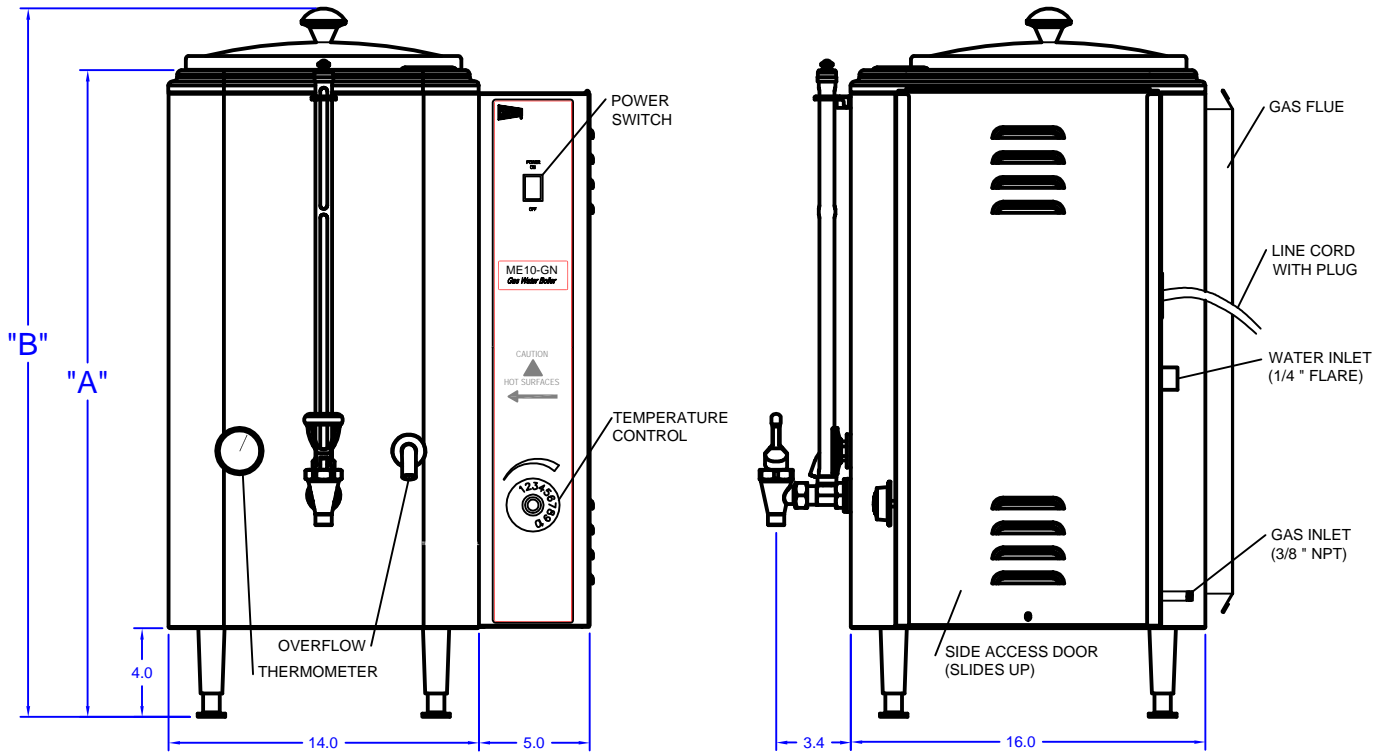

GENERAL SPECIFICATIONS

MODEL NO	WATER CAP. (GAL)	DIMENSION "A" (INCHES)	DIMENSION "B" (INCHES)	SHIPPING WT. (LB)
ME10-GN	10.0	28.0	31.0	50
ME15-GN	15.0	32.0	35.0	55

GAS SPECIFICATIONS

MODEL NO.	NATURAL GAS BTU/ HR @ 3.5" W.C.	PROPANE GAS BTU/ HR @ 10" W.C.
ME10-GN ME15-GN	12,000	12,000

ELECTRICAL SPECIFICATIONS

MODEL NO	VOLTS	WATTS	PHASE
ME10-GN ME15-GN	120	10	1

NOTE: UNIT IS SUPPLIED WITH A GROUNDED 120V-15A LINE CORD AND PLUG (NEMA 5-15P).

**FOR YOUR SAFETY
DO NOT STORE OR USE GASOLINE OR OTHER FLAMMABLE VAPORS AND
LIQUIDS IN THE VICINITY OF THIS OR ANY OTHER APPLIANCE.**

**THIS INSTALLATION MUST CONFORM WITH THE NATIONAL FUEL GAS CODE,
ANSI Z223.1 (LATEST EDITION).**

**WARNING: IMPROPER INSTALLATION, ADJUSTMENT, ALTERATION, SERVICE
OR MAINTENANCE CAN CAUSE PROPERTY DAMAGE, INJURY OR DEATH. READ
THE INSTALLATION, OPERATING AND MAINTENANCE INSTRUCTIONS
THOROUGHLY BEFORE INSTALLING OR SERVICING THIS EQUIPMENT.**

**SAFETY PRECAUTIONS
FOR YOUR SAFETY, THE FOLLOWING SAFETY PRECAUTIONS SHOULD
BE FOLLOWED AND ENFORCED.**

IF YOU SMELL GAS:

- OPEN WINDOWS
- DON'T TOUCH ELECTRICAL SWITCHES
- EXTINGUISH OPEN FLAMES
- IMMEDIATELY CALL YOUR GAS SUPPLIER

1. Instructions must be posted in a prominent location and all safety precautions taken in the event the user smells gas. Obtain this information from your local gas supplier.
2. LIGHTING: Follow the instruction on page 2 and label attached to right side of the water boiler.
3. Do not place anything over the flue opening.
4. Do not place combustibles or non-combustible materials in the proximity of coffee urn as this could cause fires or obstruct air flow to the main burners.
5. This installation must conform with local codes, or in absence of local codes with the National Fuel Gas Code ANSI Z223.1, latest edition.
6. Provide adequate air supply and ventilation.
7. Provide adequate clearance for air openings into the combustion chamber.
8. Provide clearance for servicing and proper operation. Minimum clearance from combustible construction 8" from back and 6" from side.
9. Boiler must be disconnected from gas supply during any pressure testing of pipelines in excess of ½ psig, and isolated (by turning off gas shut-off valve) during any testing less than ½ psig.
10. Retain this manual for future reference.

UNPACKING INSTRUCTION: Carefully unpack the water boiler and inspect immediately for shipping damages. Your automatic water boiler was shipped in a carton designed to give maximum protection in normal handling. It was thoroughly inspected before leaving the factory and the carrier accepted and signed for it. File any claims for shipping damage or irregularities with the carrier.

ASSEMBLY: The four legs and vent cap drain are packed separately with the water boiler. Install legs by tilting the water boiler on its side and screwing the legs into the leg supports until hand tight. Carefully right the unit and install in its permanent location, being sure to leave at least 6" on the right side of the water boiler for access to the control box. Level the unit by adjusting the bottom pad of the legs. Place the vent cap into the recess in the top of the unit. Mount the faucet assembly onto the shank in upright position.

INSTALLATION AND OPERATING INSTRUCTION:

PRE-INSTALLATION INSTRUCTIONS: The installation of your water boiler must be made by a licensed plumber and the installation must conform with State and Local Codes or in absence of Local Codes, with the National Fuel Gas Code ANSI Z223.1 a latest version.

AIR SUPPLY AND VENTILATION: Adequate ventilation and air supply must be provided in order for the water boiler to operate properly and efficiently. The area in front of and above the unit must be clear to avoid any obstruction of flow of combustion and ventilation air. DO NOT under any circumstances, connect the water boiler flue directly to a building exhaust system or place the flue outlet directly into the plenum of the exhaust hood as it will adversely affect the gas combustion of the water boiler.

CLEARANCES: Your water boiler is design certified to use on combustible floors. The side and back clearances for combustible constructions are as follows: 6 inches from side and 8 inches from back. The water boiler must be installed with 4 inch high legs provided.

GAS CONNECTION: Before connecting the water boiler to the gas line Examine the gas specification label attached to the right side panel to be certain that the type of gas for which the unit is equipped is the same as the gas supply. A 3/8 NPT gas connection is needed to connect the unit to the gas line. An accessible manual shut-off valve must be installed in the gas supply line in case of an emergency. The gas supply pipe must be sized to accommodate all the gas fired equipment that may be connected to it. Check with your local Gas Company as to proper pipe size. Sealant on all pipe joints must be resistive to propane gas. Before attempting to light the water boiler, check all joints for gas tightness using a soap and water solution.

WATER CONNECTION: The unit is supplied with 1/4" flare fitting. Connect the copper tubing with the flare fitting to the water connection at the rear of the machine. The water line must have a shut-off valve (supplied by a plumber) to a cold water supply. Water pressure should be 20 lbs. minimum for proper operation.

NOTE: Connecting the unit to a warm water supply will speed by heating and recovery time.

To turn on the water supply valve plug the line cord into a dedicated 120V grounded receptacle (NEMA 5-15R). The water will start entering the unit and automatically fill it to capacity.

PRIMING OR INITIAL FILLING: Turn on the water supply. The unit fills at the rate of 1 gallon per minute. When the water level becomes visible in the sight gauge, turn the thermostat knob to the ON position. The boiler will now automatically fill to capacity and heat the water.

LIGHTING AND ADJUSTMENT: Water must be visible in the sight glass before lighting to pilot. Turn the thermostat knob to its lowest position. Turn gas cock dial to PILOT position. Depress gas cock dial and light pilot with a long lighted match through the opening located on the bottom of the urn. Hold in depressed position for approximately 30 sec. or until pilot remains lit when dial is released.

NOTE: On the first lighting it may be necessary to hold the dial for a longer period to allow trapped air to escape from the line.

DIAL SETTINGS AND CORRESPONDING WATER TEMPERATURES:

"1" = 50F, "10" = 198F

RELIGHTING: Shut off all gas and wait approximately 5 minutes before relighting the pilot.

SHUTTING DOWN: For temporary shut down, turn the thermostat to lowest or OFF position, then turn gas cock dial to PILOT position. To shut boiler down completely, partially depress and turn gas cock dial to OFF position.

MAINTENANCE OR REPAIR: The owner should contact the manufacturer or an approved local service company for maintenance or repair of the unit.

CLEANING: The outside of the unit should be cleaned on a regular basis using a soap solution and a soft cloth or sponge. Abrasive cleaners are not recommended. For cleaning the burner see section on removal and cleaning.

FOR QUALIFIED SERVICE PERSONNEL ONLY

THERMOSTAT CALIBRATION:

To adjust the temperature of the water in the urn, turn the thermostat knob to "10" and remove the knob without moving the thermostat shaft. Place narrow bladed screwdriver (1/8") into the hollow thermostat shaft and engage center adjustment screw. When thermometer reading approaches 198F slowly turn the adjustment screw clockwise until the burner goes out. Turning the screw counter-clockwise will increase the temperature.

REPLACING SOLENOID VALVE:

1. Shut off water supply and disconnect power to the boiler.
2. Drain off approx. 1 gallon of water from the boiler.
3. Disconnect hose nut from solenoid inlet.
4. Disconnect wires from terminals on solenoid coil.
5. Remove solenoid from cabinet (2 screws).
6. Remove silicon hose from solenoid and slip onto new solenoid and assemble back in reverse order.

SAFETY PILOT:

Remove pilot adjustment cap on the gas valve and turn adjustment screw to provide properly sized flame (3/4 inch long). Replace the cap.

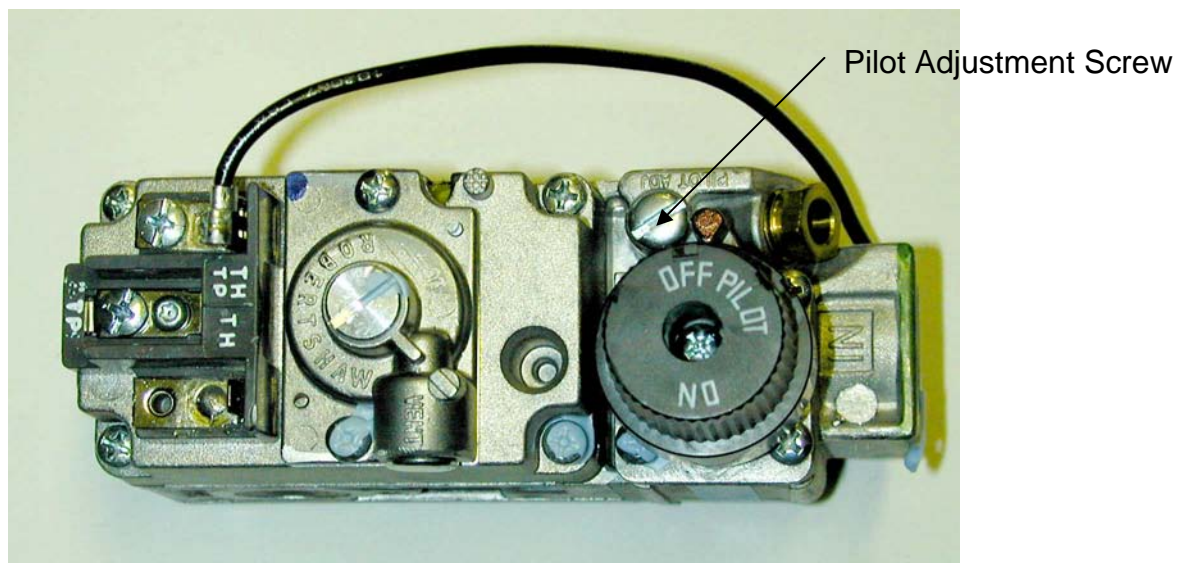

BURNER:

The burner is factory set for maximum performance. Should further adjustments be required loosen slotted hex screw on side of venturi and rotate air shutter until flame with soft blue inner core is obtained.

BURNER REMOVAL:

The burner can be removed with the unit standing in operating position. Turn off the gas flow to the unit. Allow the burner to cool off. Remove the wing nut holding the burner to the frame. Pull down the free burner end, enough to clear the threaded stud and pull the burner horizontally away from the manifold orifice. The burner can now be cleaned or replaced. To reinstall, reverse the above procedure.



BURNER MAINTENANCE:

The burner should be cleaned both inside the venturi portion and on the outside using a soft bristle brush. The burner must be replaced into the same position as prior to removal. Once a year, a qualified service agency should be contacted to inspect the appliance for safe and proper operation.

AUTOMATIC GAS WATER BOILER ME10-GN ME15-GN

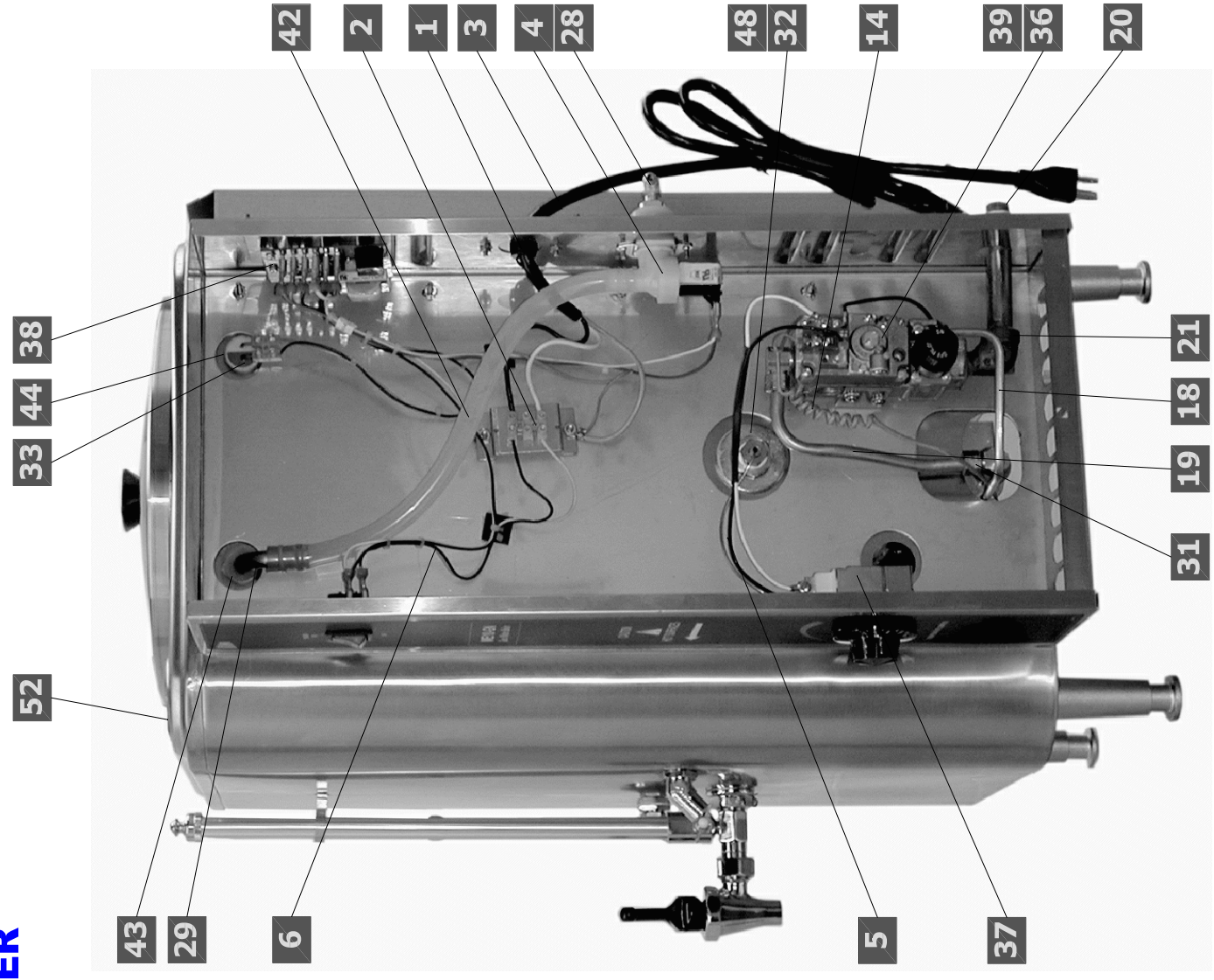
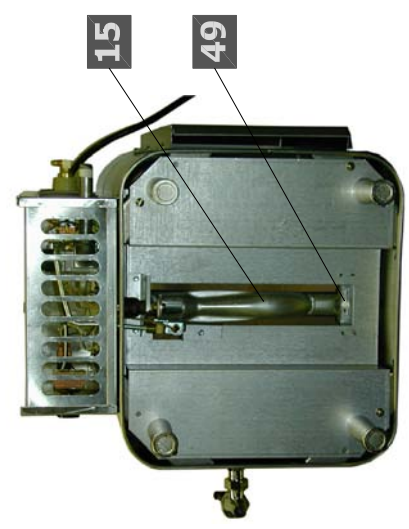
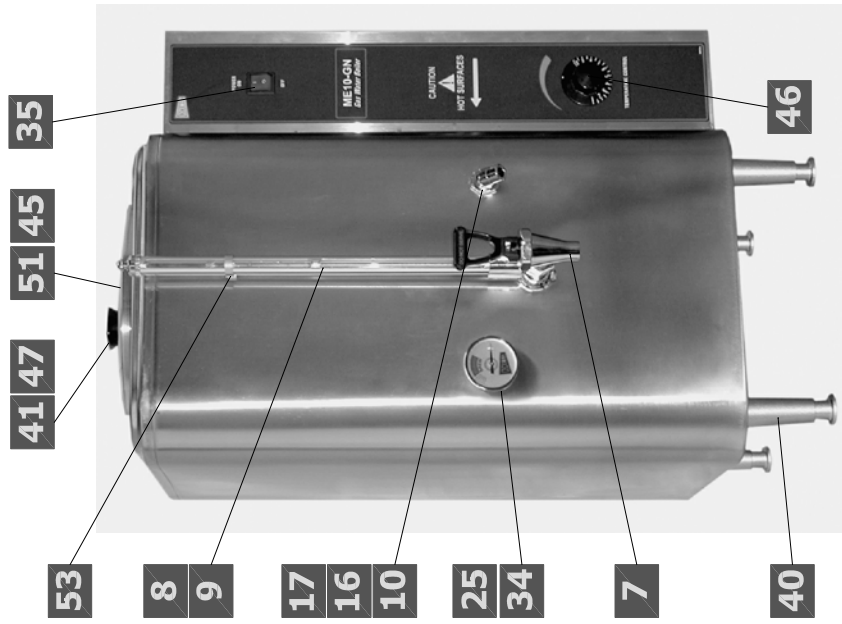

AUTOMATIC GAS WATER BOILER ME10-GN ME15-GN

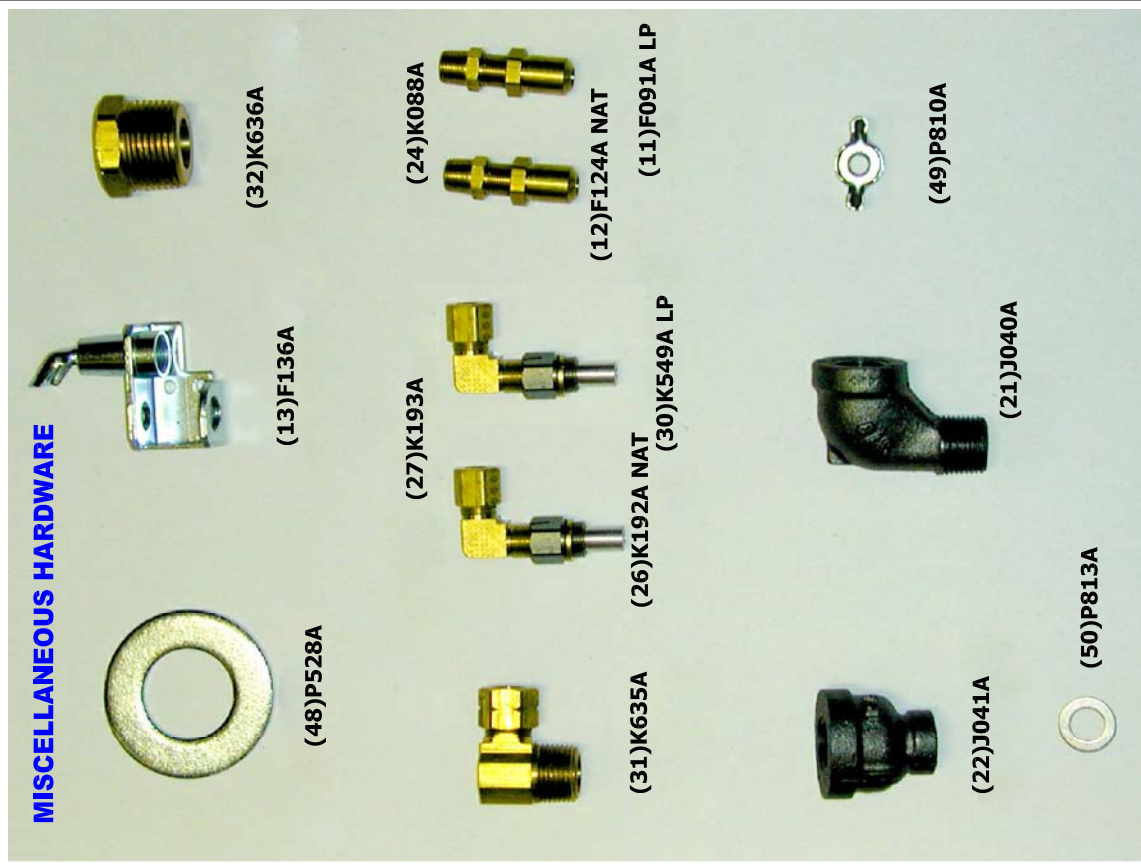
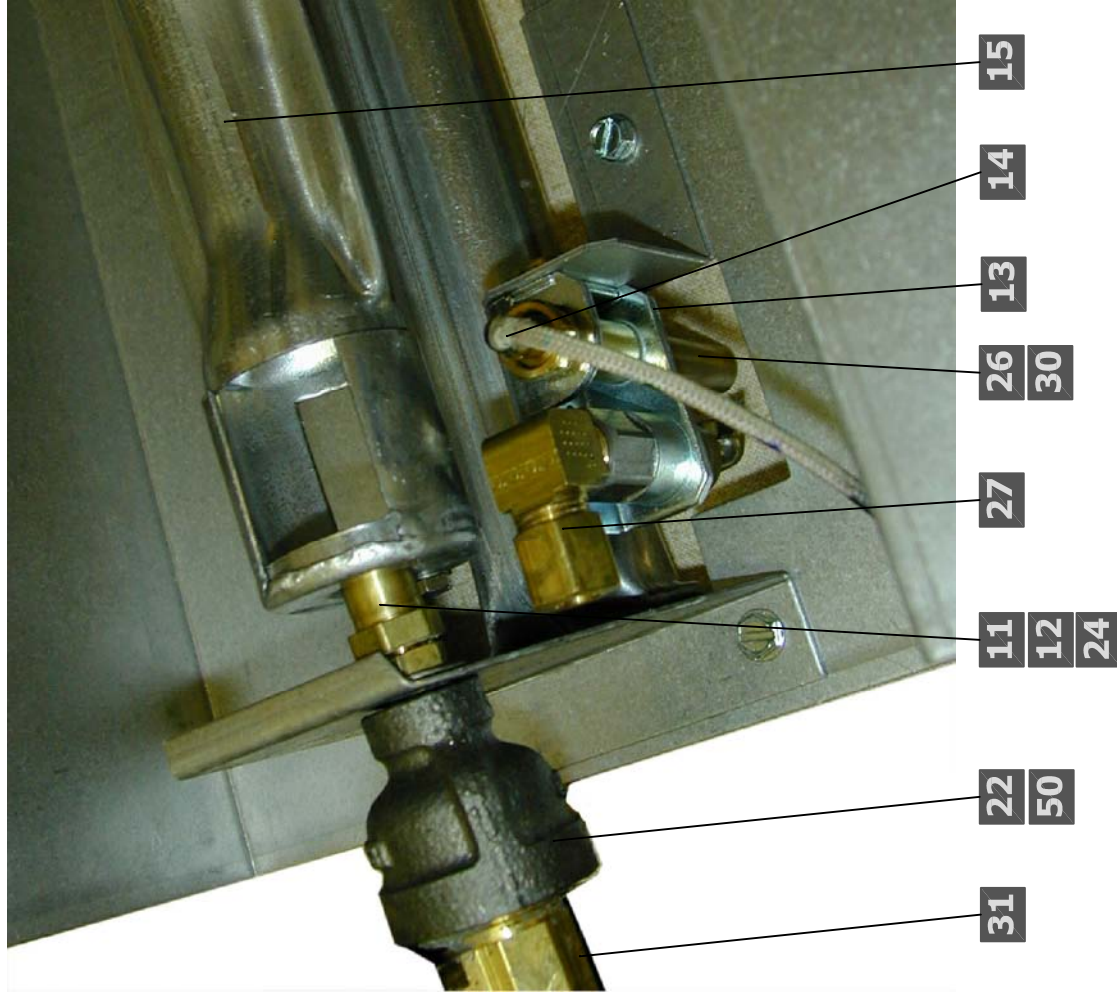

PARTS LIST

No.	PART #	DESCRIPTION	ME10-GN	ME15-GN
1	B012A	HEYCO BUSHING STRAIGHT, SMALL	1	1
2	B033A	TERMINAL BLOCK 3 POSITION	1	1
3	C032S	LINE CORD W/ PLUG 120V 15A	1	1
4	CD257	WATER INLET VALVE 120V	1	1
5	CH32A	THERMOSTAT HARNESS ASSEMBLY	1	1
6	CH415	WIRING HARNESS ASSEMBLY	1	1
7	D022Q	FAUCET, SHANK W/ VALVE	1	1
8	D031A	GUAGE SHIELD, 14 1/2"	1	0
9	D066A	GUAGE SHIELD, 18"	0	1
10	E009A	OVERFLOW FITTING W/ NUT	1	1
11	F091A	ORIFICE, LP (LP UNITS ONLY)	1	1
12	F124A	ORIFICE, NAT (NATURAL GAS UNITS ONLY)	1	1
13	F136A	PILOT HOUSING	1	1
14	F178A	THERMOPILE 24"	1	1
15	G052A	T-BURNER	1	1
16	H080A	TUBING, OVERFLOW - CU 5/8 X 16.5	0	1
17	H081A	TUBING, OVERFLOW - CU 5/8 X 13.5	1	0
18	H345A	PILOT TUBE 1/4" ALUMINUM	1	1
19	H346A	GAS VALVE TUBE 3/8" ALUMINUM	1	1
20	J015A	NIPPLE 3/8NPT x 4" BLACK STEEL	1	1
21	J040A	STREET ELBOW 3/8NPT BLACK STEEL	1	1
22	J041A	REDUCING COUPLING 3/8 x 1/8	1	1
23	K039A	1/4 x 1/8 COMPRESSION FITTING	1	1
24	K088A	ORIFICE BODY 3305 R	1	1
25	K110A	NUT, 3/8 NPT CHROMIUM PLATED	1	1
26	K192A	FITTING ALUMINUM INLET (NATURAL GAS UNITS ONLY)	1	1
27	K193A	FTG 1/8 NPT x 1/4 ANGLE	1	1
28	K491A	HOSE NUT ASSEMBLY (AMERICAN THREADS)	1	1
29	K525A	90 DEGREE ELBOW 1/2" TUBE	1	1
30	K549A	FITTING ALUMINUM INLET (LP UNITS ONLY)	1	1
31	K635A	ELBOW COMPRESSION FITTING 3/8 x 3/8 BRASS	2	2
32	K636A	HEX REDUCING BUSHING	1	1
33	K810Q	LEVEL SENSOR, DUAL PROBE	1	1
34	L007A	THERMOMETER BREW DIAL	1	1
35	L299A	ON - OFF SWITCH 20 AMP	1	1
36	L621A	GAS VALVE NAT. (NATURAL GAS UNITS)	1	1
37	L622A	THERMOSTAT	1	1
38	L690A	DUAL LEVEL CONTROL BOARD 120V	1	1
39	L347P	GAS VALVE LP. (LP UNITS ONLY)	1	1
40	M005S	LEGS, 4" ADJUSTABLE, (4/ SET)	1	1
41	M028A	KNOB, COVER	1	1
42	M326A	HOSE, WATER INLET 3/8 ID x 5/8 OD 15" LONG (FEET)	2	2
43	M461A	SEAL, SILICONE 12mm	1	1
44	M462A	SEAL, SILICONE 15mm	1	1
45	M607A	CLEAR GASKET	1	1
46	MA85A	BLACK KNOB, THERMOSTAT	1	1
47	P264A	SCREW, 10-24 X 1/2" PAN HEAD, PHILLIPS SST	2	2
48	P528A	WASHER	1	1
49	P810A	WING NUT, 10-24, SST	1	1
50	P813A	WASHER, S.S. (0.382 ID x 0.642 OD x .028 THK)	2	2
51	Q102A	COVER	1	1
52	U019A	VENT CAP DRAIN	1	1
53	U160A	GAUGE SHIELD MOUNTING BRACKET	1	1

COMPONENT TESTS

A) Thermostat Adjustments:

The Thermostat is factory set for proper dispense temperature of 200°F ± 3°F with the control knob set to the maximum clockwise position. If field adjustments are needed proceed as follows:

To DECREASE temperature, turn the control knob slightly counter-clockwise.

For qualified technicians ONLY:

To INCREASE the water temperature - With the Thermostat Knob to its maximum clockwise position, remove the knob and locate the slotted adjustment screw inside the hollow thermostat shaft, Note: glyptal may need to be removed to gain access, then using a narrow-bladed screwdriver, engage slotted adjustment screw and turn it ¼ turn slowly counter-clockwise.

Allow a few minutes for the temperature to reach set level. The Heater Light will go ON, indicating the heating element is activated, wait for it to go OFF, indicating that the water has reached new set temperature. Take a temperature reading and repeat if necessary.



B) Water Inlet Valve Test

Turn power OFF. If the water level rises inside a partially filled tank, the Water Inlet Valve is leaking. Disconnect wires from the Water Inlet Valve coil and connect a 2 wire line cord to the terminals. Plug it into a 115V outlet. If water flows in and stops when you pull it out, the Valve is working fine. Repeat this test a few times. The problem may be in the Probe or Water Level Control Board. If the water does not flow in when the cord is plugged into an electrical outlet, the Solenoid coil may be damaged, opened or the valve may have an obstruction preventing the water from flowing in. Clean or replace it.

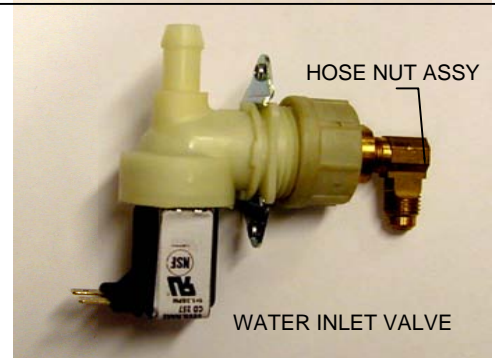

C) Dual Probe Test

If lack of water persists, check the probe as follows:

Turn on the power and water supply. Check inside the tank to make sure the water is below the Probe. Pull the BLUE wire and terminal OFF the Probe rod. If water still does not flow after the wire is disconnected from the Probe, the problem may be in the Solid State Dual Level Control Board.

If water starts flowing into the tank, the Probe may be grounded, due to excessive liming. Check with Ohm meter. Clean or replace probe.

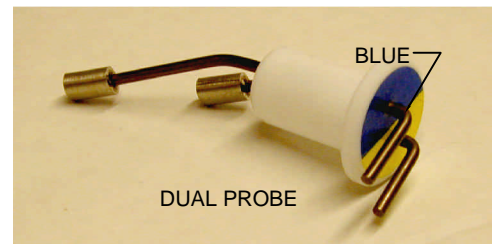

D) Dual Probe Liquid Level Controller Test

Check the Controller as follows:

1. Make sure there is power input to the Controller at the terminals AC1 & AC2

Your voltmeter should read 115 Volts. It should read the same at terminals AC1 & FILL when the water level is low. This is the output power to actuate the coil of the Solenoid Valve to open it. The lack of voltage at terminals AC1 & L-LEVEL or H-LEVEL indicates that the Controller is not working properly.

2. Make sure all wire connections are tight, including ground.
3. If after this, the Controller is still failing to open the Water Inlet Valve, replace it.

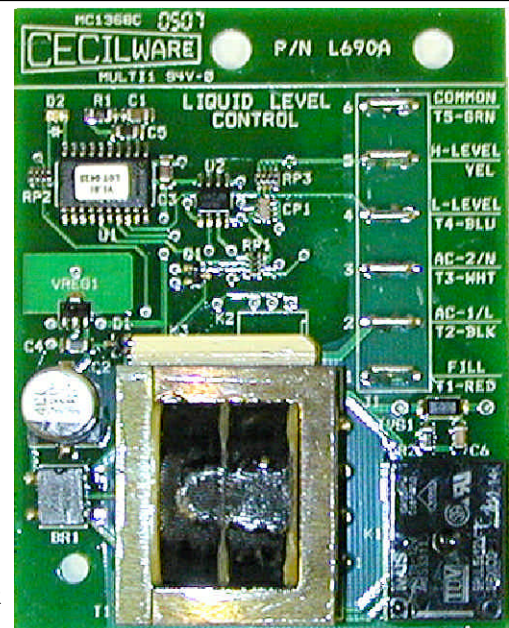

DUAL PROBE CONTROLLER

ELECTRICAL DIAGRAM ME10G-N, ME15G-N 120/ 240 VOLTS

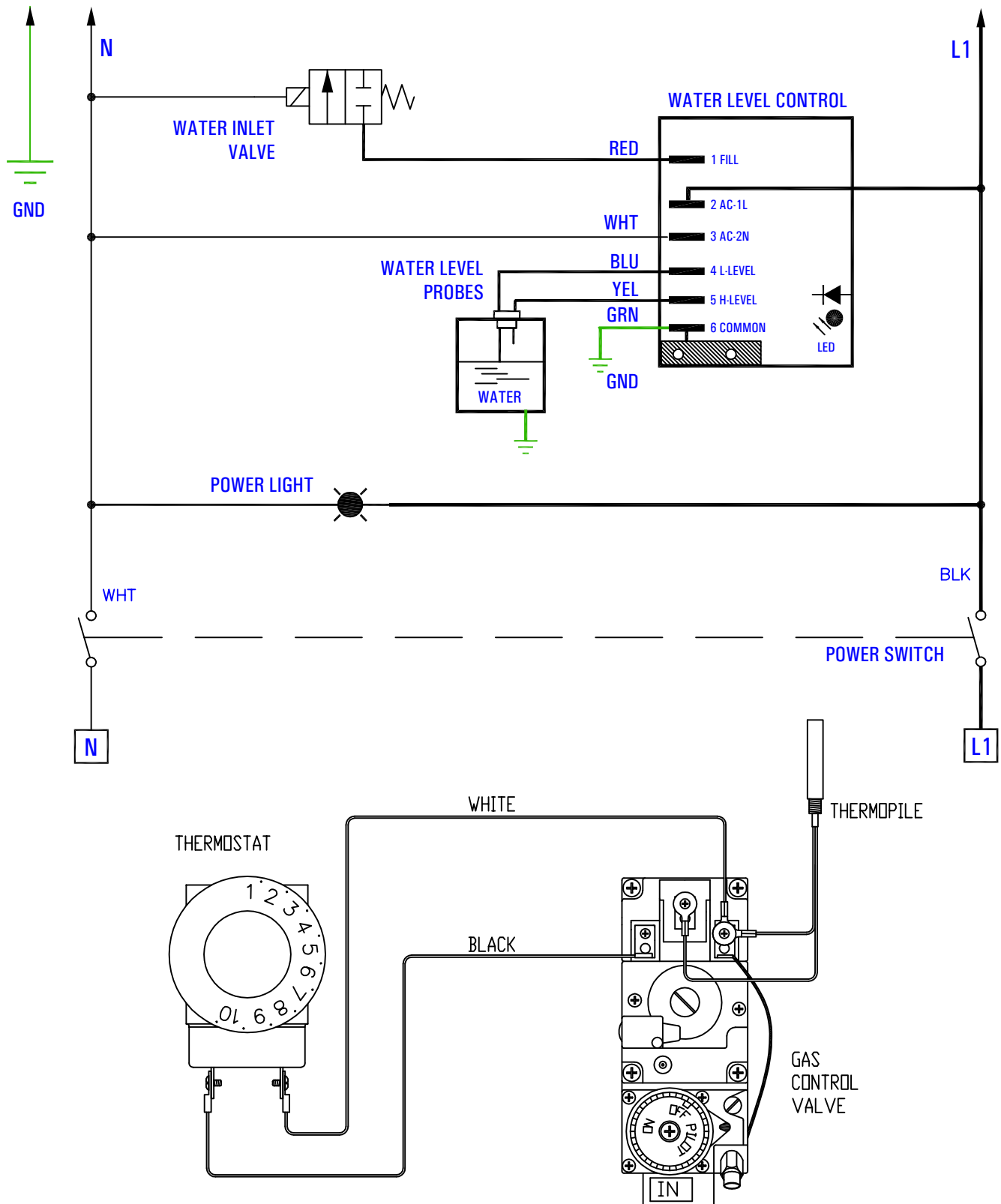

REV	BY	DATE	DESCRIPTION	APP'D BY	DATE	PART NO	SCALE
				M.M.	10/23/2006	NE280	1 : 1
<p>CECILWARE CORPORATION 43-05 20 AVE. L.I.C. NY 11105</p>							
<p>TITLE: ELECTRICAL DIAGRAM, ME10G-N/ME15G-N</p>							<p>REV.</p>