



# Overview

---

This chapter provides information about these topics:

- [Setting up the Switch, page 1-1](#)
- [Features, page 1-1](#)
- [Front-Panel Description, page 1-2](#)
- [Rear-Panel Description, page 1-9](#)
- [Management Options, page 1-11](#)

## Setting up the Switch

See the *Catalyst 2940 Switch Getting Started Guide* for instructions on initially configuring your Catalyst switch by using the Express Setup. Also covered in the getting started guide are switch management options, basic rack-mounting procedures, port and module connections, power connection procedures, and troubleshooting help. For instructions on setting up your switch by using the command-line interface (CLI), see [Appendix C, “Configuring the Switch with the CLI-Based Setup Program.”](#)

## Features

The Catalyst 2940 switches are a family of Ethernet switches that you can use to connect workstations and other network devices, such as servers, routers, and other switches. All models of the switch are cluster-capable.

See the switch software configuration guide for examples that show how you might deploy the switches in your network.

These are the switch features:

- Hardware
  - Catalyst 2940-8TT-S switch—Eight 10/100 Ethernet ports and one Gigabit Ethernet 10/100/1000 port.
  - Catalyst 2940-8TF-S switch—Eight 10/100 Ethernet ports, one 100BASE-FX port, and one small-form-factor pluggable (SFP) module slot. The Cisco SFP modules that are supported by this switch include the 1000BASE-LX, 1000BASE-SX, Coarse Wavelength Division Multiplexing (CDWM) fiber-optic modules, and the 1000BASE-T copper module.

- Configuration
  - Supports manual and autoconfiguration for 10/100 ports
  - Supports manual configuration at 10 or 100 Mbps for 10/100/1000 port (full duplex only at 1000 Mbps)
  - Supports only 100 Mbps and full duplex for 100BASE-FX port
  - Supports 8192 MAC addresses
  - Checks for errors on a received packet, determines the destination port, stores the packet in shared memory, and then forwards the packet to the destination port

## Front-Panel Description

The switch front panel contains the ports, the LEDs, and the Mode button.

Figure 1-1 and Figure 1-2 show the switches.

**Figure 1-1 Catalyst 2940-8TT-S Switch**

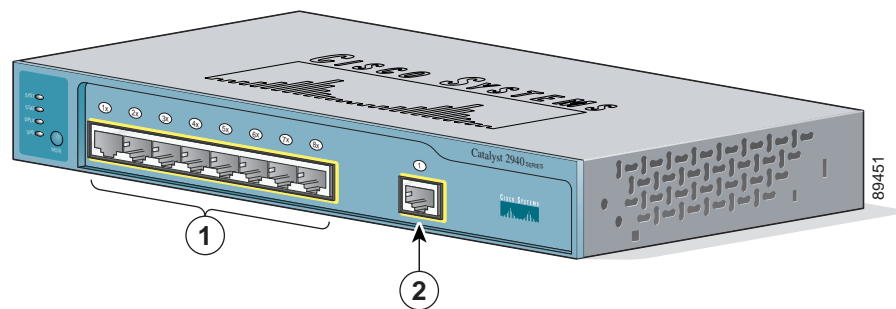

1	10/100 Ethernet ports
2	10/100/1000 Gigabit Ethernet port

**Figure 1-2 Catalyst 2940-8TF-S Switch**

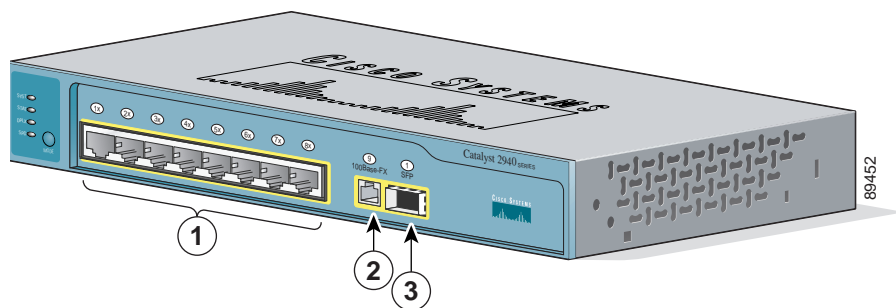

1	10/100 Ethernet ports
2	100BASE-FX port
3	SFP module slot

## Port Numbering

Table 1-1 lists the port and slot numbering for the Catalyst 2940 switches.

**Table 1-1 Port and Slot Numbering**

Port or Slot type	Catalyst 2940-8TT-S	Catalyst 2940-8TF-S
10/100 Ethernet	1 through 8	1 through 8
Gigabit Ethernet 10/100/1000	1	—
100BASE-FX	—	9
SFP module	—	1

## 10/100 Ports

The 10/100 ports use RJ-45 connectors and twisted-pair cabling. The ports can connect to these devices:

- 10BASE-T devices, such as workstations and hubs, through standard RJ-45 connectors and two twisted-pair cabling. You can use Category 3, 4, or 5 cabling.
- 100BASE-TX devices, such as high-speed workstations, servers, hubs, routers, and other switches, through standard RJ-45 connectors and two or four twisted-pair, Category 5 cabling.



### Note

When connecting the switch to workstations, servers, and routers, be sure that the cable is a twisted-pair straight-through cable. When connecting the switch to hubs or other switches, use a twisted-pair crossover cable. Pinouts for the cables are described in [Appendix B, “Connectors and Cables.”](#)

The 10/100 ports can be explicitly set to operate in any combination of half duplex, full duplex, 10 Mbps, or 100 Mbps. They can also be set for speed and duplex autonegotiation, compliant with IEEE 802.3U. In all cases, the cable length from a switch to an attached device cannot exceed 328 feet (100 meters).

When set for autonegotiation, a port senses the speed and duplex settings of the attached device and advertises its own capabilities. If the attached device supports autonegotiation, the port negotiates the best connection (that is, the fastest line speed that both devices support and full-duplex transmission, if the attached device supports it) and configures itself accordingly.

## 10/100/1000 Port

The 10/100/1000 port on the Catalyst 2940-8TT-S switch uses RJ-45 connectors and twisted-pair cabling. The port can connect to these devices:

- 10BASE-T devices, such as workstations and hubs, through standard RJ-45 connectors and two or four twisted-pair, Category 5 cabling.
- 100BASE-TX devices, such as high-speed workstations, servers, hubs, routers, and other switches, through standard RJ-45 connectors and two or four twisted-pair, Category 5 cabling.
- 1000BASE-T devices, such as high-speed workstations, servers, hubs, routers, and other switches, through standard RJ-45 connectors and four twisted-pair, Category 5 cabling.

**Note**

When connecting the switch to a 1000BASE-T device, be sure to use a four twisted-pair, Category 5 cable.

**Note**

When connecting the switch to workstations, servers, and routers, be sure to use a twisted-pair straight-through cable. When connecting the switch to hubs or other switches, use a twisted-pair crossover cable. Pinouts for the cables are described in [Appendix B, “Connectors and Cables.”](#)

The 10/100/1000 port on the Catalyst 2940-8TT-S switch can be explicitly set to operate at full- or half-duplex at 10 or 100 Mbps. The port is restricted to full-duplex mode when it is set at 1000 Mbps.

The port can also be set for speed autonegotiation, compliant with IEEE 802.3AB. In all cases, the cable length from a switch to an attached device cannot exceed 328 feet (100 meters).

## 100BASE-FX Port

The 100BASE-FX port on the Catalyst 2940-8TF-S switch can use either 50/125- or 62.5/125-micron multimode fiber-optic cabling. The 100BASE-FX port operates only at 100 Mbps in full-duplex mode.

In full-duplex mode, the cable length from the 100BASE-FX port to an attached device cannot exceed 6562 feet (2 kilometers).

You can use only the 100BASE-FX port or the SFP module slot at one time. When the switch is first powered on, the 100BASE-FX port is enabled by default. However, if an SFP module is already installed in the switch, the SFP module slot is enabled.

You can connect the 100BASE-FX port to an SC port on a target device by using one of the MT-RJ fiber-optic patch cables listed in [Table 1-2](#). Use the Cisco part numbers in [Table 1-2](#) to order the patch cables that you need.

**Table 1-2 MT-RJ Patch Cables for 100BASE-FX Connections**

Type	Cisco Part Number
1-meter, MT-RJ-to-SC multimode cable	CAB-MTRJ-SC-MM-1M=
3-meter, MT-RJ-to-SC multimode cable	CAB-MTRJ-SC-MM-3M=
5-meter, MT-RJ-to-SC multimode cable	CAB-MTRJ-SC-MM-5M=

## SFP Module Slot

The SFP module slot supports copper or fiber-optic SFP modules. The SFP module slot is numbered as port 1.

**Note**

You can use only the SFP module slot or the 100BASE-FX port at one time. When the switch is first powered on, the 100BASE-FX port is enabled by default. However, if an SFP module is already installed in the switch, the SFP module slot is enabled.

If you install an SFP module after the switch has powered on, you must reload the switch to enable the SFP module.

## SFP Modules

The Catalyst 2940-8TF-S switch uses a field-replaceable SFP module to establish Gigabit connections. You insert an SFP module into the SFP module slot on the front of the switch.

The Cisco SFP modules that are supported by the Catalyst 2940-8TF-S switch include:

- 1000BASE-LX, fiber-optic
- 1000BASE-SX, fiber-optic
- 1000BASE-T, copper
- Coarse Wavelength-Division Multiplexing (CDWM), fiber-optic



Note

The Catalyst 2940-8TF-S switch only supports 1000 Mbps and full-duplex modes on SFP modules.

The 1000BASE-LX and 1000BASE-SX SFP modules are used to establish fiber-optic connections. You use fiber-optic cables with LC connectors to connect to an SFP module. The SFP modules support 850 to 1550 nm nominal wavelengths. These field-replaceable modules provide the uplink optical interfaces, laser send (TX), and laser receive (RX).

The restrictions are that each port must match the wave-length specifications on the other end of the cable, and the cable must not exceed the stipulated cable length for reliable communications. [Table 1-3](#) lists these stipulations.

**Table 1-3** Cabling Stipulations for Fiber-Optic SFP Modules

SFP Module	62.5/125 micron Multimode 850 nm <sup>1</sup> Fiber	50/125 micron Multimode 850 nm Fiber	62.5/125 micron Multimode 1310 nm Fiber	50/125 micron Multimode 1310 nm Fiber	9/125 micron Single-mode 1310 nm Fiber	8 micron Single-mode Dispersion Shifted Fiber
SX	275 m <sup>2</sup> at 200 Mhz-km	550 m at 500 Mhz-km				—
LX	—	—	550 m at 500 Mhz-km	550 m at 400 Mhz-km	10 km	—
CWDM <sup>3</sup>	1470, 1490, 1510, 1530, 1550, 1570, 1590, 1610	SMF	9/125	—	62 miles (100 km)	1470, 1490, 1510, 1530, 1550, 1570, 1590, 1610

1. nm = nanometer

2. m = meter

3. CWDM = Coarse Wavelength-Division Multiplexing

The 1000BASE-T SFP module is used to establish a Gigabit Ethernet connection through a Category 5 (copper) cable. This module can provide a Gigabit Ethernet connection of up to 100 meters through a Category 5 cable.

Use only Cisco SFP modules on the Catalyst 2940-8TF-S switch. Each SFP module has an internal serial EEPROM that is encoded with security information. This encoding provides a way for Cisco to identify and validate that the SFP module meets the requirements for the switch.

The Cisco CWDM SFPs operate on single-mode fiber. The SFPs support both Gigabit Ethernet as well as fiber channel (1 Gigabit and 2 Gigabit) links. For more information about Cisco CWDM SFPs, see the *Cisco CWDM SFP Transceiver Compatibility Matrix* at this URL:

[http://www.cisco.com/en/US/products/hw/modules/ps4999/products\\_device\\_support\\_table09186a00803bf095.html](http://www.cisco.com/en/US/products/hw/modules/ps4999/products_device_support_table09186a00803bf095.html)

Also see your SFP module documentation and the *Cisco Small Form-Factor Pluggable Modules Installation Notes* (not orderable but is available on Cisco.com).

For the latest information about SFP modules supported by the switch, see the release notes.

## Cable Guard

You can order an optional cable guard to secure cables to the front of the switch and prevent them from being accidentally removed. To order a cable guard, contact your Cisco representative.

## LEDs

There are four LEDs on the left panel of the switch, and there are port status LEDs above all the switch ports, as shown in [Figure 1-3](#).

**Figure 1-3 LEDs on Catalyst 2940 Switches**

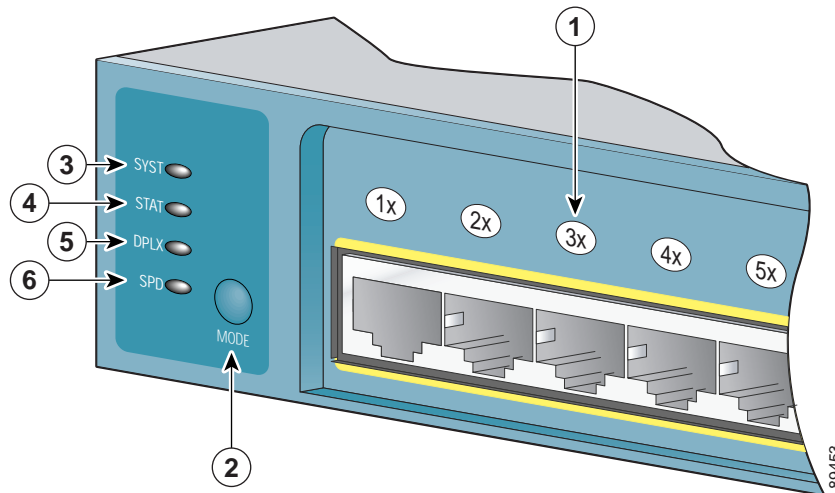

1	Port status LED	4	STAT LED
2	Mode button	5	DPLX LED
3	SYST LED	6	SPD LED

You can use these LEDs to monitor switch activity and performance:

- The system (SYST) continually displays the system status. The SYST LED color shows the switch status.
- The status (STAT), duplex (DPLX), and speed (SPD) LEDs show the information that is being displayed by the port status LEDs. Pressing the Mode button cycles the LEDs through the STAT, DPLX, and SPD displays.

All of the LEDs described in this section are visible through the GUI management applications—the Network Assistant application for multiple switches and the device manager for a single switch. The switch software configuration guide describes how to use the CLI to configure and to monitor individual switches and switch clusters.

## SYST LED

The SYST LED shows whether the system is receiving power and functioning properly. [Table 1-4](#) lists the LED colors and meanings.

**Table 1-4 System LED**

Color	System Status
Off	System is not powered on.
Green	System is operating normally.
Amber	System is receiving power but is not functioning properly.

For information about the system LED colors during the power-on self-test (POST), see the [“Understanding POST Results”](#) section on page 3-1.

## STAT, DPLX, SPD, and Port LEDs

Press the Mode button to cycle through the STAT, DPLX, and SPD LED displays. When the LED is highlighted for the mode that you want, release the button to enable that highlighted mode.

[Table 1-5](#) lists the mode meanings.

**Table 1-5 Port Mode LEDs**

Mode LED	Port Mode	Description
STAT	Port status	Port status. This is the default mode.
DPLX	Port duplex mode	Port duplex mode: half duplex or full duplex.
SPD	Port speed	Port operating speed: 10 or 100 Mbps for 10/100 ports and 10, 100, or 1000 Mbps for 10/100/1000 ports.

Each port has a port status LED, also called a port LED. These LEDs display information about the individual ports. When you change the port mode, the meanings of the port LED colors change.

[Table 1-6](#) explains how to interpret these colors.

**Table 1-6** *Meaning of Port LED Colors in Different Modes*

Port Mode	Color	Meaning
STAT	Off	No link.
	Solid green	Link present.
	Flashing green	Activity. Port is sending or receiving data.
	Alternating green-amber	Link fault. Error frames can affect connectivity, and errors such as excessive collisions, CRC errors, and alignment and jabber errors are monitored for a link-fault indication.
	Solid amber	Port is not forwarding. Port was disabled by management, an address violation, or Spanning Tree Protocol (STP).  <b>Note</b> After a port is reconfigured, the port LED can remain amber for up to 30 seconds while STP checks the switch for possible loops.
DPLX	Off	Port is operating in half duplex.
(half or full duplex)	Green	Port is operating in full duplex.
SPD	10/100 ports	
	Off	Port is operating at 10 Mbps.
	Green	Port is operating at 100 Mbps.
	10/100/1000 ports	
	Off	Port is operating at 10 Mbps.
	Green	Port is operating at 100 Mbps.
	Flashing green	Port is operating at 1000 Mbps.
	SFP modules	
	Off	Port is operating at 10 Mbps.
	Green	Port is operating at 100 Mbps.
	Flashing green	Port is operating at 1000 Mbps.



# Rear-Panel Description

The rear panel of the switches, as shown in [Figure 1-4](#), have an AC power connector and an RJ-45 console port.

**Figure 1-4 Catalyst 2940 Switch Rear Panel**

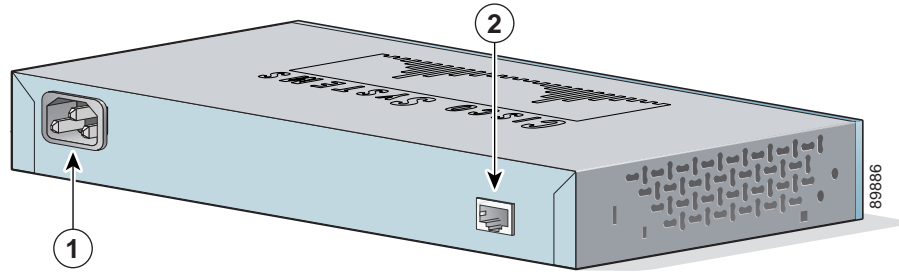

1	AC power connector
2	RJ-45 console port

## Power Connector

You provide power to a switch by using the AC internal power supply. The internal AC power supply is an autoranging unit that supports input voltages between 100 and 240 VAC. Use the supplied AC power cord to connect the AC power connector to an AC power outlet.

The switch accessory kit includes an L-shaped AC power cord. [Table 1-7](#) lists the spare L-shaped AC power cords that you can order from your Cisco sales representative.

**Table 1-7 Spare L-Shaped Power Cords**

Type	Cisco Part Number
110 V	CAB-AC-RA=
Argentina	CAB-ACR-RA=
Australia, 10 A	CAB-ACA-RA=
China	CAB-ACC-RA=
Europe	CAB-ACE-RA=
Italy	CAB-ACI-RA=
Japan	CAB-JPN-RA=
Switzerland	CAB-ACS-RA=
UK	CAB-ACU-RA=

## Console Port

You can connect a switch to a PC through the console port by using a RJ-45-to-DB-9 adapter cable.

If you want to connect a switch to a terminal, you need to provide an RJ-45-to-DB-25 female DTE adapter. You can order a kit (part number ACS-DSBUASYN=) with that adapter from Cisco.

For console-port and adapter-pinout information, see the [“Cable and Adapter Specifications” section on page B-5](#).

## Security Slots

The switches have security slots in the left and right side panels. You can install an optional cable lock, such as the type that is used to secure a laptop computer, to secure either or both sides of the switch.

[Figure 1-5](#) shows the slot on a left-side panel.

**Figure 1-5** Switch Left Panel

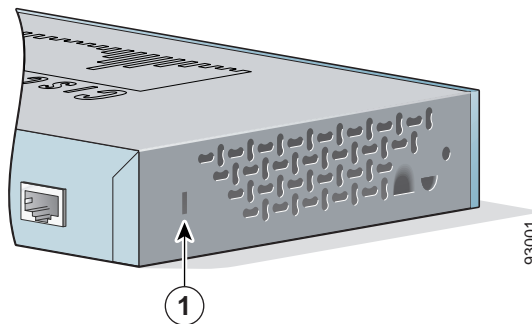

1	Security slot
---	---------------

Cable locks are available from most computer accessory suppliers.

# Management Options

Catalyst 2940 switches offer these management options:

- Network Assistant

The Network Assistant is a GUI-based application that you can install and run on your desktop; you do not need a web browser to run it. You can use Network Assistant to manage and monitor switch clusters or standalone devices. For more information, see the *Getting Started with Cisco Network Assistant* guide and the Network Assistant online help.

- Device manager

You can use the device manager, which is in the switch memory, to manage individual and standalone switches. The device manager is accessible after you have run the Express Setup program (see the getting started guide for more information about running Express Setup). Use the device manager to perform basic switch configuration and monitoring. You can access the device manager from anywhere in your network through a web browser.

To launch the device manager, enter the switch IP address in the web browser, and press **Enter**. The device manager page appears.

See the device manager online help for more information.

- Cisco IOS CLI

You can manage switches by using command-line entries. To access the CLI, connect a PC or a terminal directly to the console port on the switch. If the switch is attached to your network, you can use a Telnet connection to manage the switch from a remote location. For more information about the CLI, see the switch command reference.

- CiscoView application

You can use the CiscoView device-management application to set configuration parameters and to view switch status and performance information. This application, which you purchase separately, can be a standalone application or part of an Simple Network Management Protocol (SNMP) network-management platform. For more information, see the documentation that came with your CiscoView application.

- SNMP network management

You can manage switches by using an SNMP-compatible management station running platforms such as HP OpenView and SunNet Manager. The switch supports a comprehensive set of MIB extensions and MIB II, the IEEE 802.1D bridge MIB, and four Remote Monitoring (RMON) groups. For more information, see the documentation that came with your SNMP application.

