



Doc. No. 78-5172-01

Installing the Cisco RPS Adapter Plate in Cisco 2600 Series Routers

Product Number: ACS-2600RPS=

This document describes how to install an adapter plate in Cisco 2600 series routers for use with the Cisco Redundant Power System (RPS). The Cisco RPS provides power system redundancy to external devices (such as routers, switches, or hubs). The system includes two fully redundant AC input power modules and four DC output power modules for connection to external devices. The Cisco RPS supports quasi-redundant and fully redundant power source configurations. To use the Cisco RPS with Cisco 2600 series routers, you must remove the existing power supply and replace it with a Cisco RPS adapter plate.

This document includes the following sections:

- Safety Recommendations on page 1
- Required Tools and Equipment on page 4
- Removing the Cover on page 5
- Removing the Power Supply on page 7
- Installing the Redundant Power Supply Adapter Plate on page 8
- Obtaining Service and Support on page 11
- Cisco Connection Online on page 11
- Ordering Documentation on page 12

Safety Recommendations

Follow these guidelines to ensure general safety:

- Keep the chassis area clear and dust-free during and after installation.
- Put the removed chassis cover in a safe place.

Corporate Headquarters

Cisco Systems, Inc.
170 West Tasman Drive
San Jose, CA 95134-1706
USA

Copyright © 1998
Cisco Systems, Inc.
All rights reserved.

- Keep tools away from walk areas where you or others could fall over them.
- Do not wear loose clothing that could get caught in the chassis. Fasten your tie or scarf and roll up your sleeves.
- Wear safety glasses when working under any conditions that might be hazardous to your eyes.
- Do not perform any action that creates a potential hazard to people or makes the equipment unsafe.

Safety Warnings

Safety warnings appear throughout this publication in procedures that, if performed incorrectly, might harm you. A warning symbol precedes each safety warning.



Warning This warning symbol means *danger*. You are in a situation that could cause bodily injury. Before you work on any equipment, be aware of the hazards involved with electrical circuitry and be familiar with standard practices for preventing accidents.

Waarschuwing Dit waarschuwingssymbool betekent gevaar. U verkeert in een situatie die lichamelijk letsel kan veroorzaken. Voordat u aan enige apparatuur gaat werken, dient u zich bewust te zijn van de bij elektrische schakelingen betrokken risico's en dient u op de hoogte te zijn van standaard maatregelen om ongelukken te voorkomen.

Varoitus Tämä varoitusmerkki merkitsee vaaraa. Olet tilanteessa, joka voi johtaa ruumiinvammaan. Ennen kuin työskentelet minkään laitteiston parissa, ota selvää sähkökytkentöihin liittyvistä vaaroista ja tavanomaisista onnettomuuksien ehkäisykeinoista.

Attention Ce symbole d'avertissement indique un danger. Vous vous trouvez dans une situation pouvant causer des blessures ou des dommages corporels. Avant de travailler sur un équipement, soyez conscient des dangers posés par les circuits électriques et familiarisez-vous avec les procédures couramment utilisées pour éviter les accidents.

Warnung Dieses Warnsymbol bedeutet Gefahr. Sie befinden sich in einer Situation, die zu einer Körperverletzung führen könnte. Bevor Sie mit der Arbeit an irgendeinem Gerät beginnen, seien Sie sich der mit elektrischen Stromkreisen verbundenen Gefahren und der Standardpraktiken zur Vermeidung von Unfällen bewußt.

Avvertenza Questo simbolo di avvertenza indica un pericolo. La situazione potrebbe causare infortuni alle persone. Prima di lavorare su qualsiasi apparecchiatura, occorre conoscere i pericoli relativi ai circuiti elettrici ed essere al corrente delle pratiche standard per la prevenzione di incidenti.

Advarsel Dette varselsymbolet betyr fare. Du befinner deg i en situasjon som kan føre til personskade. Før du utfører arbeid på utstyr, må du være oppmerksom på de faremomentene som elektriske kretser innebærer, samt gjøre deg kjent med vanlig praksis når det gjelder å unngå ulykker.

Aviso Este símbolo de aviso indica perigo. Encontra-se numa situação que lhe poderá causar danos físicos. Antes de começar a trabalhar com qualquer equipamento, familiarize-se com os perigos relacionados com circuitos eléctricos, e com quaisquer práticas comuns que possam prevenir possíveis acidentes.

¡Advertencia! Este símbolo de aviso significa peligro. Existe riesgo para su integridad física. Antes de manipular cualquier equipo, considerar los riesgos que entraña la corriente eléctrica y familiarizarse con los procedimientos estándar de prevención de accidentes.

Warning! Denna varningssymbol signalerar fara. Du befinner dig i en situation som kan leda till personskada. Innan du utför arbete på någon utrustning måste du vara medveten om farorna med elkretsar och känna till vanligt förfarande för att förebygga skador.

To see translations of the remaining warnings that appear in this publication, refer to the *Regulatory Compliance and Safety Information* document that accompanied the device.

Safety with Electricity

Follow these guidelines when working on equipment powered by electricity:



Warning Read the installation instructions before you connect the system to its power source.



Warning Ultimate disposal of this product should be handled according to all national laws and regulations.



Warning Only trained and qualified personnel should be allowed to install or replace this equipment.



Warning Before working on a chassis or working near power supplies, unplug the power cord on AC units; disconnect the power at the circuit breaker on DC units.



Warning Before working on equipment that is connected to power lines, remove jewelry (including rings, necklaces, and watches). Metal objects will heat up when connected to power and ground, and can cause serious burns or weld to the terminals.

- Locate the emergency power-OFF switch in the room in which you are working. Then, if an electrical accident occurs, you can quickly shut the power OFF.
- Disconnect all power before doing the following:
 - Installing or removing a chassis
 - Working near power supplies
- Do not work alone if potentially hazardous conditions exist.
- Never assume that power is disconnected from a circuit. Always check.
- Look carefully for possible hazards in your work area, such as moist floors, ungrounded power extension cables, and missing safety grounds.
- If an electrical accident occurs, proceed as follows:
 - Use caution; do not become a victim yourself.
 - Turn OFF power to the system.
 - If possible, send another person to get medical aid. Otherwise, determine the condition of the victim and then call for help.
 - Determine if the person needs rescue breathing or external cardiac compressions; then take appropriate action.



Caution Use the Cisco RPS (model PWR600-AC-RPS) only to power the external device.

Required Tools and Equipment

Seul le système d'alimentation redondant Cisco (RPS modèle PWR600-AC-RPS) doit servir à alimenter le dispositif externe.

Das externe Gerät darf nur mit einer redundanten Stromversorgung von Cisco, Modell PWR600-AC-RPS, betrieben werden.

外付部品の電源には、必ず Cisco RPS (モデル番号 PWR600-AC-RPS-CAB/PWR600-AC-RPS-NCAB) を

Para alimentar el dispositivo externo, usar exclusivamente el sistema de alimentación redundante (redundant power system = RPS) Cisco, modelo PWR600-AC-RPS.

Preventing Electrostatic Discharge Damage

Electrostatic discharge (ESD) can damage equipment and impair electrical circuitry. It occurs when electronic printed circuit cards are improperly handled and can result in complete or intermittent failures. Always follow ESD prevention procedures when removing and replacing cards. Ensure that the chassis is electrically connected to earth ground. Wear an ESD-preventive wrist strap, ensuring that it makes good skin contact. Connect the clip to an unpainted surface of the chassis frame to safely channel unwanted ESD voltages to ground. To properly guard against ESD damage and shocks, the wrist strap and cord must be used correctly. If no wrist strap is available, ground yourself by touching the metal part of the chassis.



Caution For safety, periodically check the resistance value of the antistatic strap, which should be between 1 and 10 megohms (Mohm).

Required Tools and Equipment

This kit includes the following items:

- Cisco RPS adapter plate, shown in Figure 1
- DC power rating label

Figure 1 Cisco RPS Adapter Plate for Cisco 2600 series Routers

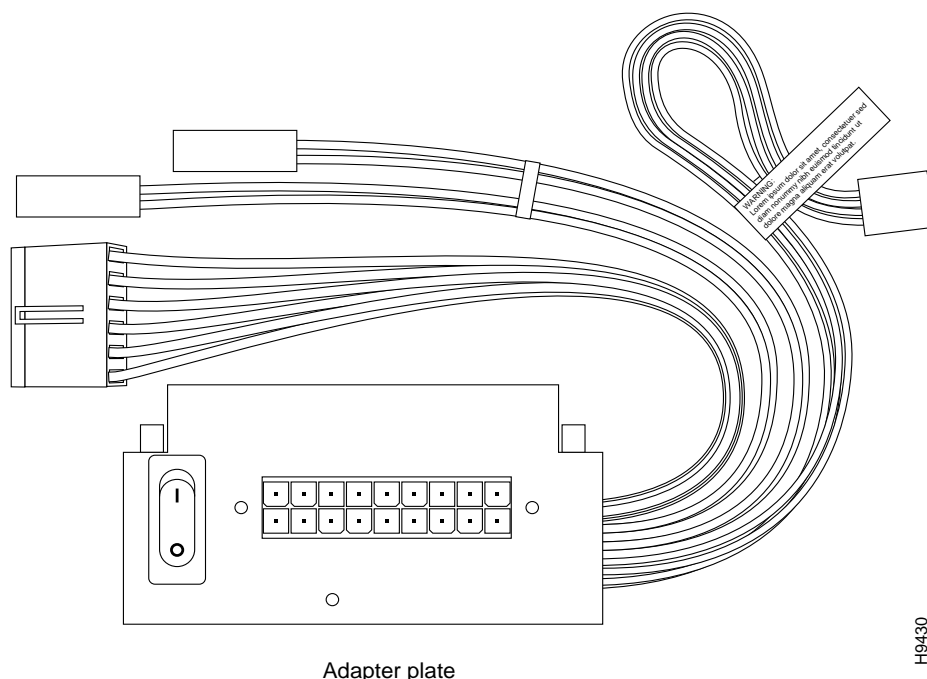

To install the Cisco RPS adapter plate, you will also need the following tools and equipment (which are not included):

- Cisco 2600 series router
- Medium-size Phillips screwdriver
- ESD-preventive wrist strap
- Antistatic bag (optional)
- Wire cutters or scissors for cutting the cable tie-wraps (optional)

Removing the Cover

You must remove the chassis cover to access the internal power supply.



Warning Do not touch the power supply when the power cord is connected. For systems with a power switch, line voltages are present within the power supply even when the power switch is OFF and the power cord is connected. For systems without a power switch, line voltages are present within the power supply when the power cord is connected.



Warning Before performing any of the following procedures, ensure that power is removed from the DC circuit. To ensure that all power is OFF, locate the circuit breaker on the panel board that services the DC circuit, switch the circuit breaker to the OFF position, and tape the switch handle of the circuit breaker in the OFF position.

Removing the Cover

Take these steps to remove the chassis cover:

- Step 1** Power OFF the router.
- Step 2** Attach an ESD-preventive wrist strap.
- Step 3** Disconnect all cables from the rear panel of the router.



Warning Before opening the chassis, disconnect the telephone-network cables to avoid contact with telephone-network voltages.



Warning Do not work on the system or connect or disconnect cables during periods of lightning activity.

- Step 4** Place the router so that the front panel is facing you. Remove the screws located on top of the cover near the front edge.
- Step 5** Slide the cover away from you until the metal tabs on the side edges separate from the chassis bottom, as shown in Figure 2.

Figure 2 Removing the Cover

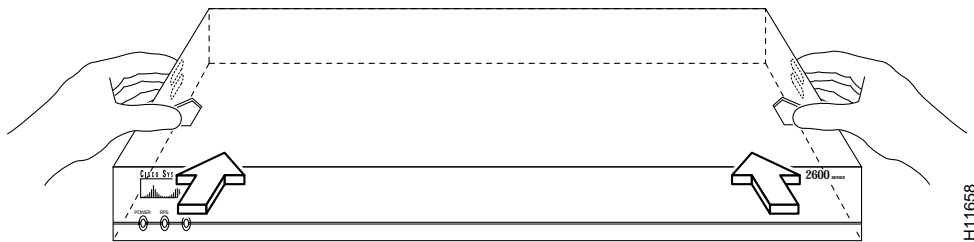

- Step 6** Lift the front edge of the cover until it clears the front of the chassis, as shown in Figure 3.

Figure 3 Lifting the Cover

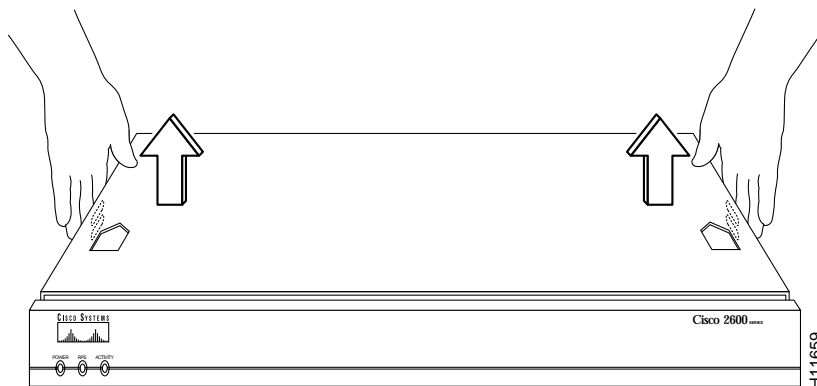

- Step 7** Lift the cover until it is free from the chassis and then set it aside.

Removing the Power Supply

This section describes how to remove the internal power supply. Although the AC power supply is shown in the illustrations that follow, the procedure is the same for removing both the AC and DC power supplies.

Take these steps to remove the power supply:

- Step 1** Locate the six-pin connector on the system board near the front of the router, and disconnect it. (See Figure 4.)

Note If cable tie-wraps on the harness interfere with removing the connectors, cut the tie-wraps, being careful not to cut the power supply wires.

Figure 4 Locating the Connectors

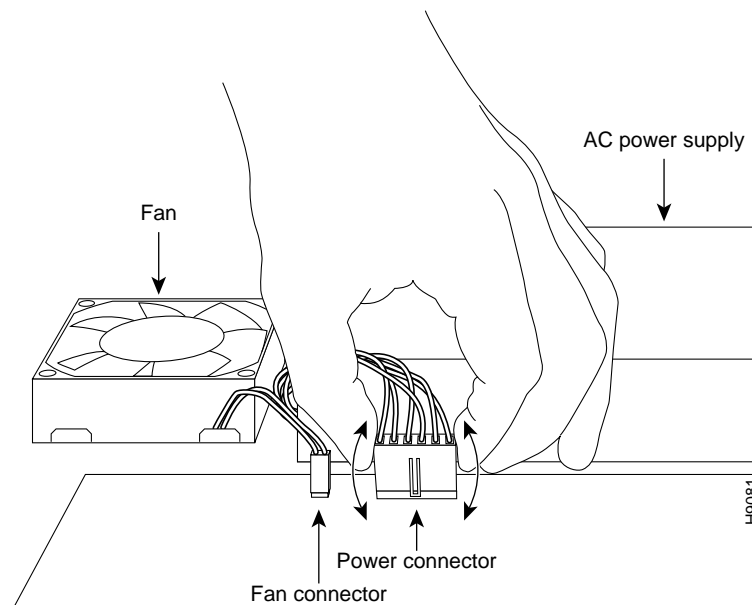

- Step 2** Remove the mounting screw that secures the power supply to the chassis. (See Figure 5.) Set aside this screw for later use.

Figure 5 Removing the Mounting Screw

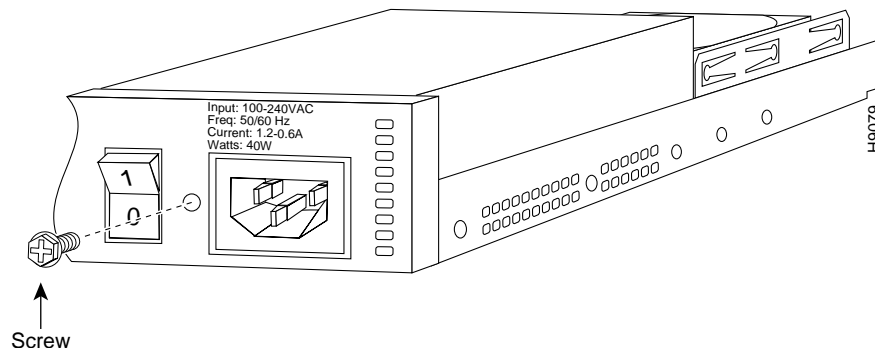

Step 3 Slide the power supply forward slightly in the chassis. This disengages the built-in hooks that help secure the power supply to the chassis. (See Figure 6.)

Figure 6 Removing the Power Supply

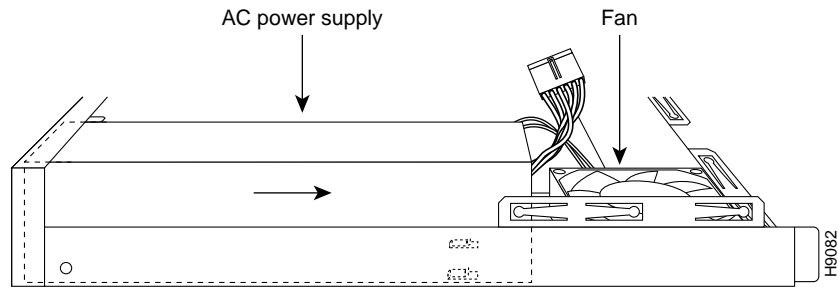

Step 4 Place the removed screw and power supply in an antistatic bag.

Installing the Redundant Power Supply Adapter Plate

Take these steps to install the Cisco RPS Adapter Plate:

Step 1 Place the router so that the rear panel is facing you. (See Figure 7.)

Figure 7 Cisco 2600 Series Rear Panel (Cisco 2610 Shown)

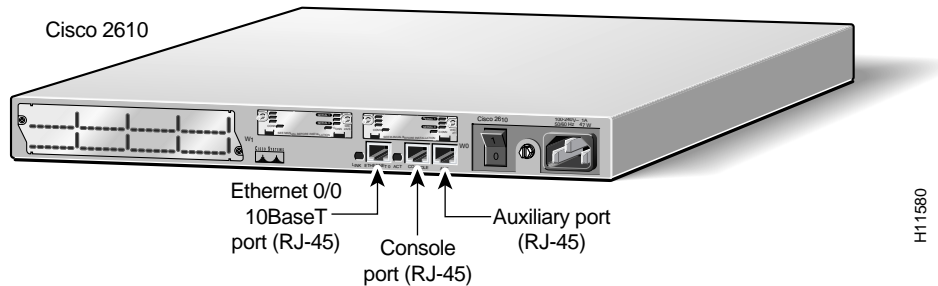

Step 2 Attach the DC power rating label over the ratings on the rear panel of the router. (See Figure 8.)

Figure 8 Attaching the DC Power Rating Label

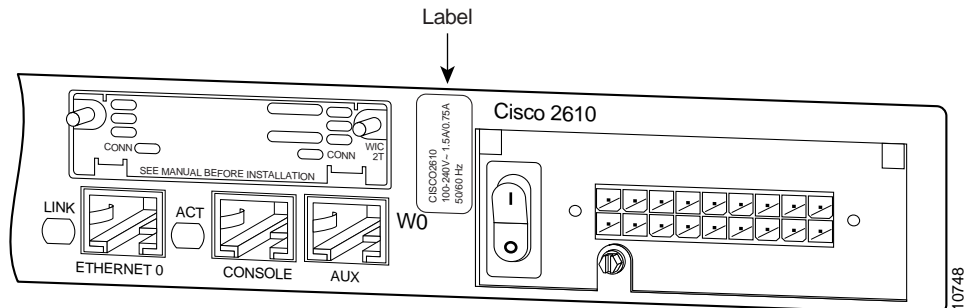

- Step 3** Align the Cisco RPS Adapter Plate with the chassis cutout for the power supply. Tilt the adapter plate slightly toward you at the top, and rock it up and into place, ensuring that the two small hooks at the top of the Adapter Plate engage the router chassis. (See Figure 9.)

Figure 9 Installing the Cisco RPS Adapter Plate

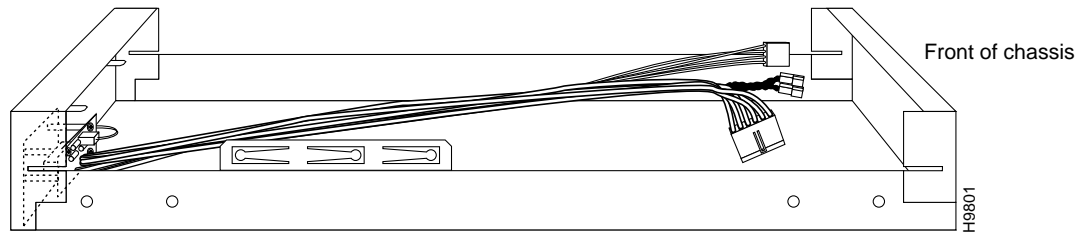

- Step 4** Install the mounting screw that came with the Cisco RPS Adapter Plate into the screw hole. (See Figure 10.)

Figure 10 Installing the Mounting Screw

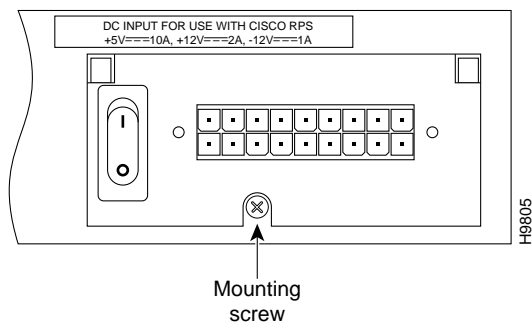

- Step 5** Connect the six-pin connector to the system board. The connector is keyed so that it cannot be connected to the system board incorrectly. (See Figure 11.)
- Step 6** Connect the 4-pin environmental status connector only if your router, with the connector connected, has been upgraded to the correct level of Cisco IOS software. Using any other level of Cisco IOS software can cause the router to crash. Cisco IOS Release 11.1(12)AA or later is compatible but will not show status from the RPS. Cisco IOS Release 11.2(7)P or later will provide RPS status information to the network.

Figure 11 Reconnecting the Connectors

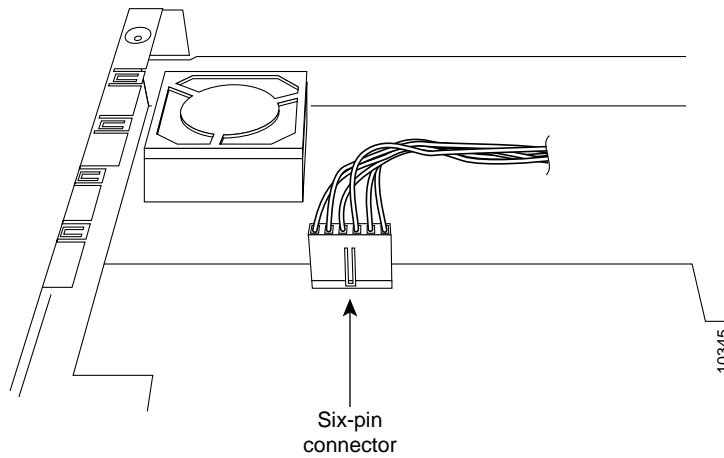

Replacing the Cover

Take the following steps to replace the cover:

- Step 1** Position the two chassis sections, as shown in Figure 2.
- Step 2** Referring to Figure 2, press the two chassis sections together and ensure the following:
- The top section fits *into* the rear of the bottom section. The bottom section fits *into* the front of the top section.
 - Each side of the top and bottom sections fits together.



Caution To fit the two sections together, it might be necessary to work them together at one end and then the other, working back and forth; however, use care to prevent bending of the chassis edges.

- Step 3** When the two sections fit together snugly, slide the chassis top so until it fits into the front bezel.
- Step 4** Replace the cover screws. Tighten the screws to no more than 8 or 9 inches/pound of torque.
- Step 5** Reinstall the chassis on the wall, rack, desktop, or table.
- Step 6** Reconnect all cables.

Obtaining Service and Support

For service and support for a product purchased from a reseller, contact the reseller. Resellers offer a wide variety of Cisco service and support programs, which are described in the section “Service and Support” in the information packet that shipped with your chassis.

Note If you purchased your product from a reseller, you can access Cisco Connection Online (CCO) as a guest. CCO is Cisco Systems’ primary, real-time support channel. Your reseller offers programs that include direct access to CCO’s services.

For service and support for a product purchased directly from Cisco, use CCO.

Cisco Connection Online

Cisco Connection Online (CCO) is Cisco Systems’ primary, real-time support channel. Maintenance customers and partners can self-register on CCO to obtain additional information and services.

Available 24 hours a day, 7 days a week, CCO provides a wealth of standard and value-added services to Cisco’s customers and business partners. CCO services include product information, product documentation, software updates, release notes, technical tips, the Bug Navigator, configuration notes, brochures, descriptions of service offerings, and download access to public and authorized files.

CCO serves a wide variety of users through two interfaces that are updated and enhanced simultaneously: a character-based version and a multimedia version that resides on the World Wide Web (WWW). The character-based CCO supports Zmodem, Kermit, Xmodem, FTP, and Internet e-mail, and it is excellent for quick access to information over lower bandwidths. The WWW version of CCO provides richly formatted documents with photographs, figures, graphics, and video, as well as hyperlinks to related information.

You can access CCO in the following ways:

- WWW: <http://www.cisco.com>
- WWW: <http://www-europe.cisco.com>
- WWW: <http://www-china.cisco.com>
- Telnet: cco.cisco.com
- Modem: From North America, 408 526-8070; from Europe, 33 1 64 46 40 82. Use the following terminal settings: VT100 emulation; databits: 8; parity: none; stop bits: 1; and connection rates up to 28.8 kbps.

For a copy of CCO’s Frequently Asked Questions (FAQ), contact cco-help@cisco.com. For additional information, contact cco-team@cisco.com.

Note If you are a network administrator and need personal technical assistance with a Cisco product that is under warranty or covered by a maintenance contract, contact Cisco’s Technical Assistance Center (TAC) at 800 553-2447, 408 526-7209, or tac@cisco.com. To obtain general information about Cisco Systems, Cisco products, or upgrades, contact 800 553-6387, 408 526-7208, or cs-rep@cisco.com.

Ordering Documentation

Cisco documentation and additional literature are available in a CD-ROM package, which ships with your product. The Documentation CD-ROM, a member of the Cisco Connection Family, is updated monthly. Therefore, it might be more current than printed documentation. To order additional copies of the Documentation CD-ROM, contact your local sales representative or call customer service. The CD-ROM package is available as a single package or as an annual subscription. You can also access Cisco documentation on the World Wide Web at <http://www.cisco.com>, <http://www-china.cisco.com>, or <http://www-europe.cisco.com>.

If you are reading Cisco product documentation on the World Wide Web, you can submit comments electronically. Click **Feedback** in the toolbar, select **Documentation**, and click **Enter the feedback form**. After you complete the form, click **Submit** to send it to Cisco. We appreciate your comments.

This document is to be used in conjunction with the *Cisco 2600 Series Hardware Installation Guide* publication.

AccessPath, AtmDirector, the CCIE logo, CD-PAC, Centri, Centri Bronze, Centri Gold, Centri Security Manager, Centri Silver, the Cisco Capital logo, Cisco IOS, the Cisco IOS logo, *CiscoLink*, the Cisco NetWorks logo, the Cisco Powered Network logo, the Cisco Press logo, ClickStart, ControlStream, Fast Step, FragmentFree, IGX, JumpStart, Kernel Proxy, LAN²LAN Enterprise, LAN²LAN Remote Office, MGX, MICA, Natural Network Viewer, NetBeyond, NetRanger, NetSonar, Netsys Technologies, *Packet*, PIX, Point and Click Internetworking, Policy Builder, RouteStream, Secure Script, SMARTnet, StrataSphere, StrataSphere BILLder, StrataSphere Connection Manager, StrataSphere Modeler, StrataSphere Optimizer, Stratm, StreamView, SwitchProbe, *The Cell*, TrafficDirector, TransPath, VirtualStream, VlanDirector, Workgroup Director, Workgroup Stack, and XCI are trademarks; Empowering the Internet Generation and The Network Works. No Excuses. are service marks; and BPX, Catalyst, Cisco, Cisco Systems, the Cisco Systems logo, EtherChannel, FastHub, FastPacket, ForeSight, IPX, LightStream, OptiClass, Phase/IP, StrataCom, and StrataView Plus are registered trademarks of Cisco Systems, Inc. in the U.S. and certain other countries. All other trademarks mentioned in this document are the property of their respective owners.

Copyright © 1998, Cisco Systems, Inc.
All rights reserved. Printed in USA.
9803R