



BLACK BOX
NETWORK SERVICES

LGC200A
LGC201A
LGC202A

Pure Networking™ Gigabit Media Converters

Link a 1000BASE-TX segment to a 1000BASE-FX segment on your network, and extend the 328-foot (100-m) distance limit of copper-based Ethernet.



Customer Support Information

Order toll-free in the U.S.: Call 877-877-BBOX (outside U.S. call 724-746-5500) • FREE technical support 24 hours a day, 7 days a week: Call 724-746-5500 or fax 724-746-0746 • Mailing address: Black Box Corporation, 1000 Park Drive, Lawrence, PA 15055-1018
Web site: www.blackbox.com • E-mail: info@blackbox.com

Trademarks Used in this Manual

Trademarks Used in this Manual

Black Box and the Double Diamond logo are registered trademarks, and Pure Networking is a trademark, of BB Technologies, Inc.

Any other trademarks mentioned in this manual are acknowledged to be the property of the trademark owners.

FEDERAL COMMUNICATIONS COMMISSION AND INDUSTRY CANADA RADIO FREQUENCY INTERFERENCE STATEMENTS

Class B Digital Device. This equipment has been tested and found to comply with the limits for a Class B computing device pursuant to Part 15 of the FCC Rules. These limits are designed to provide reasonable protection against harmful interference in a residential installation. However, there is no guarantee that interference will not occur in a particular installation. This equipment generates, uses, and can radiate radio frequency energy, and, if not installed and used in accordance with the instructions, may cause harmful interference to radio communications. If this equipment does cause harmful interference to radio or telephone reception, which can be determined by turning the equipment off and on, the user is encouraged to try to correct the interference by one of the following measures:

- Reorient or relocate the receiving antenna.
- Increase the separation between the equipment and receiver.
- Connect the equipment into an outlet on a circuit different from that to which the receiver is connected.
- Consult an experienced radio/TV technician for help.

Caution:

Changes or modifications not expressly approved by the party responsible for compliance could void the user's authority to operate the equipment.

To meet FCC requirements, shielded cables and power cords are required to connect this device to a personal computer or other Class B certified device.

This digital apparatus does not exceed the Class B limits for radio noise emission from digital apparatus set out in the Radio Interference Regulation of Industry Canada.

Le présent appareil numérique n'émet pas de bruits radioélectriques dépassant les limites applicables aux appareils numériques de classe B prescrites dans le Règlement sur le brouillage radioélectrique publié par Industrie Canada.

Normas Oficiales Mexicanas (NOM) Electrical Safety Statement INSTRUCCIONES DE SEGURIDAD

1. Todas las instrucciones de seguridad y operación deberán ser leídas antes de que el aparato eléctrico sea operado.
2. Las instrucciones de seguridad y operación deberán ser guardadas para referencia futura.
3. Todas las advertencias en el aparato eléctrico y en sus instrucciones de operación deben ser respetadas.
4. Todas las instrucciones de operación y uso deben ser seguidas.
5. El aparato eléctrico no deberá ser usado cerca del agua—por ejemplo, cerca de la tina de baño, lavabo, sótano mojado o cerca de una alberca, etc.
6. El aparato eléctrico debe ser usado únicamente con carritos o pedestales que sean recomendados por el fabricante.
7. El aparato eléctrico debe ser montado a la pared o al techo sólo como sea recomendado por el fabricante.
8. Servicio—El usuario no debe intentar dar servicio al equipo eléctrico más allá a lo descrito en las instrucciones de operación. Todo otro servicio deberá ser referido a personal de servicio calificado.
9. El aparato eléctrico debe ser situado de tal manera que su posición no interfiera su uso. La colocación del aparato eléctrico sobre una cama, sofá, alfombra o superficie similar puede bloquea la ventilación, no se debe colocar en libreros o gabinetes que impidan el flujo de aire por los orificios de ventilación.
10. El equipo eléctrico deber ser situado fuera del alcance de fuentes de calor como radiadores, registros de calor, estufas u otros aparatos (incluyendo amplificadores) que producen calor.
11. El aparato eléctrico deberá ser conectado a una fuente de poder sólo del tipo descrito en el instructivo de operación, o como se indique en el aparato.

12. Precaución debe ser tomada de tal manera que la tierra física y la polarización del equipo no sea eliminada.
13. Los cables de la fuente de poder deben ser guiados de tal manera que no sean pisados ni pellizcados por objetos colocados sobre o contra ellos, poniendo particular atención a los contactos y receptáculos donde salen del aparato.
14. El equipo eléctrico debe ser limpiado únicamente de acuerdo a las recomendaciones del fabricante.
15. En caso de existir, una antena externa deberá ser localizada lejos de las líneas de energía.
16. El cable de corriente deberá ser desconectado del cuando el equipo no sea usado por un largo periodo de tiempo.
17. Cuidado debe ser tomado de tal manera que objetos líquidos no sean derramados sobre la cubierta u orificios de ventilación.
18. Servicio por personal calificado deberá ser provisto cuando:
 - A: El cable de poder o el contacto ha sido dañado; u
 - B: Objetos han caído o líquido ha sido derramado dentro del aparato; o
 - C: El aparato ha sido expuesto a la lluvia; o
 - D: El aparato parece no operar normalmente o muestra un cambio en su desempeño; o
 - E: El aparato ha sido tirado o su cubierta ha sido dañada.

Table of Contents

Table of Contents

1.	Specifications.....	7
2.	Overview	8
2.1	Introduction	8
2.2	Features	8
2.3	What's Included.....	9
2.4	Connectors and Network Cables Supported	9
2.5	Hardware Description.....	10
2.5.1	LGC201A	10
2.5.2	LGC202A.....	12
2.5.3	LGC200A.....	14
3.	Configuration	16
4.	Installation	18
4.1	Typical Installation.....	18
4.1.1	LGC201A and LGC202A.....	18
4.1.2	LGC200A.....	19
4.2	Installation Procedure.....	20
5.	Operation	23
5.1	LEDs on the Media Converter	23
5.2	Force/Auto Switch	25
6.	Troubleshooting.....	26
6.1	Contacting Black Box.....	26
6.2	Shipping and Packaging	26

1. Specifications

Maximum Distance — LGC201A: Multimode fiber optic: 0.55 km,
LGC202A: Single-mode fiber optic: 15 km

Standards — IEEE 802.3ab,802.3z

Connectors — LGC201A: (1) dual SC, (1) RJ-45;
LGC202A: (1) dual SC, (1) RJ-45;
LGC200A: Depends on installed SFP module

Temperature Tolerance — Operating: +32 to +104° F (0 to +40° C);
Storage: -40 to +158° F (-40 to +70° C)

Humidity — Operating: 10 to 90% relative humidity, noncondensing;
Storage: 5 to 90% relative humidity, noncondensing'

Power — External: 100–240 VAC, 50–60 Hz, 0.3 A;
Output: 9 VDC, 0.6 A, 5.4 W maximum

Size — 1.1"H x 3.7"W x 2.9"D (2.7 x 9.4 x 7.4 cm)

Weight — 1.1 lb. (0.5 kg)

Chapter 2: Overview

2. Overview

2.1 Introduction

The Pure Networking LGC200A, LGC201A and LGC202A are Gigabit Media Converters. The SFP port of the LGC200A supports hot-swappable, Gigabit SFP modules. The LGC201A has a dual SC multimode fiber connector, and the LGC202A has a dual SC single-mode fiber connector.

Use the media converters to join a 1000BASE-TX segment to a 1000BASE-SX or 1000BASE-LX segment on your network, or use them in pairs to extend the 328-feet (100-m) distance limitation of copper-based Ethernet.

Three converter models are available:

- LGC200A: This SFP module media converter transmits/receives data based on the SFP module that is installed.
- LGC201A: This fiber SC media converter transmits/receives data by 850-nm short-wave laser over multimode fiber.
- LGC202A: This fiber SC media converter transmits/receives data by 1310-nm short-wave laser over single-mode fiber.

2.2 Features

- Complies with 802.3ab and 802.3z standards.
- Provides (1) SC/LC connector or (1) SFP module slot and (1) RJ-45 connector.
- Both TX and FX ports work at 1000 Mbps in full-duplex mode.
- Supports Auto MDI/MDI-X for the TX port.
- Extends fiber distance up to 0.55 kilometers for multimode fiber and 15 kilometers for single-mode fiber.
- Easy-to-view LED indicators provide status to easily monitor network activity.
- Uses a 9-VDC, 600 mA external power supply (included).

2.3 What's Included

Your package should contain the following items. If anything is missing or damaged, contact Black Box Technical Support at 724-746-5500 or info@blackbox.com.

- (1) Pure Networking Gigabit Media Converter
- (1) 9-VDC, 600 mA power adapter
- This user's manual

2.4 Connectors and Network Cables Supported

The connectors and network cables supported by the converter are listed as follows.

- Connectors: RJ-45, SC, LC.
- Network Cables: CAT5 twisted-pair (TP), 850-nm, 62.5/125- μ m or 50/125- μ m multimode fiber; or 1310-nm 9/125- μ m single-mode fiber.

Table 2-1. Connectors and network cable supported.

Part Number	Interface	Transmission Distance	Transmission Media	Output Center Wavelength
LGC200A	RJ-45 TP and fiber	Depends on SFP used	Multimode/single-mode fiber	Depends on SFP used
LGC201A	RJ-45 TP and SC fiber	0.55 km	50/125- μ m multimode fiber, TP	850 nm
		0.22 km	62.5/125 μ m multimode fiber, TP	
LGC202A	RJ-45 TP and SC fiber	15 km	Single-mode fiber, TP	1310 nm

Chapter 2: Overview

2.5 Hardware Description

Figures 2-1 through 2-6 show the front and back panels of the media converters. Tables 2-2 through 2-4 describe their components.

2.5.1 LGC201A

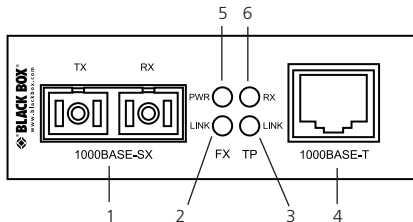

Figure 2-1. Front panel of the LGC201A.



Figure 2-2. Back panel of the LGC201A.

Table 2-2. LGC201A components.

Number	Component	Description
1	(1) dual SC connector (TX/RX)	Links to fiber segment
2	(1) FX Link LED	Lights ON when there is a valid link. Flashing when the converter is receiving or transmitting data from the fiber optic connector. OFF when there is no valid link.
3	(1) TP Link LED	Lights ON when there is a valid link. Flashing when the converter is receiving or transmitting data from the twisted-pair port. OFF when there is no valid link.
4	(1) RJ-45 connector	Links to 1000BASE-T device
5	(1) PWR LED	Lights ON when power to the chassis is on; OFF when power is off.
6	(1) RX LED	Lights ON when the TP port is connected to 1000BASE-TX. OFF when the TP port is not connected.
7	(1) barrel connector	Links to power
8	(1) switch for the FX port	Selects Force or Auto-negotiation mode

Chapter 2: Overview

*See Table 5-1 for LED functions.

2.5.2 LGC202A

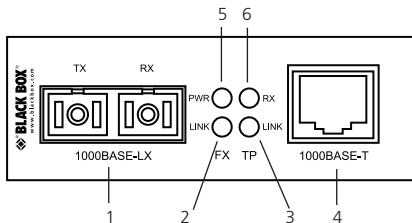

Figure 2-3. Front panel of the LGC202A.



Figure 2-4. Back panel of the LGC202A.

Table 2-3. LGC202A components.

Number	Component	Description
1	(1) dual SC connector (TX/RX)	Links to fiber segment
2	(1) FX Link LED	Lights ON when there is a valid link. Flashing when the converter is receiving or transmitting data from the fiber optic connector. OFF when there is no valid link.
3	(1) TP Link LED	Lights ON when there is a valid link. Flashing when the converter is receiving or transmitting data from the twisted-pair port. OFF when there is no valid link.
4	(1) RJ-45 connector	Links to 1000BASE-T device
5	(1) PWR LED	Lights ON when power to the chassis is on; OFF when power is off.
6	(1) RX LED	Lights ON when the TP port is connected to 1000BASE-TX. OFF when the TP port is not connected.
7	(1) barrel connector	Links to power
8	(1) switch for the FX port	Selects Force or Auto-negotiation mode

*See Table 5-1 for LED functions.

2.5.3 LGC200A

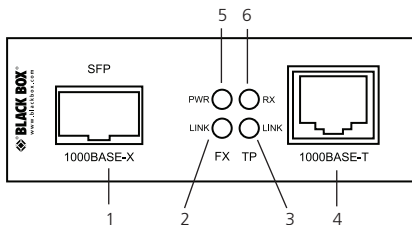

Figure 2-5. Front panel of the LGC200A.

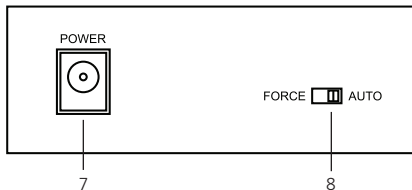

Figure 2-6. Back panel of the LGC200A.

Table 2-4. LGC200A components.

Number	Component	Description
1	(1) SFP slot for SFP module	Links to fiber segment
2	(1) FX Link LED	Lights ON when there is a valid link. Flashing when the converter is receiving or transmitting data from the fiber optic connector. OFF when there is no valid link.
3	(1) TP Link LED	Lights ON when there is a valid link. Flashing when the converter is receiving or transmitting data from the twisted-pair port. OFF when there is no valid link.
4	(1) RJ-45 connector	Links to 1000BASE-T device
5	(1) PWR LED	Lights ON when power to the chassis is on; OFF when power is off.
6	(1) RX LED	Lights ON when the TP port is connected to 1000BASE-TX. OFF when the TP port is not connected.
7	(1) barrel connector	Links to power
8	(1) switch for the FX port	Selects Force or Auto-negotiation mode

Chapter 3: Configuration

3. Configuration

To expand a Gigabit Ethernet network, you can use the converter as described in the following examples:

1. Place two converters back to back between the end devices as shown in Figure 3-1.

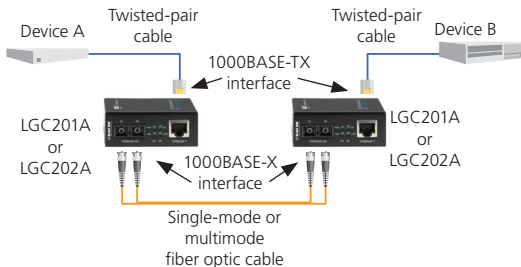

Figure 3-1. Application using two converters.

NOTE: Use two LGC201A Media Converters or two LGC202A media converters to expand your network.

2. Place one converter directly between a 1000BASE-TX network segment and a fiber optic network segment as shown in Figure 3-2.

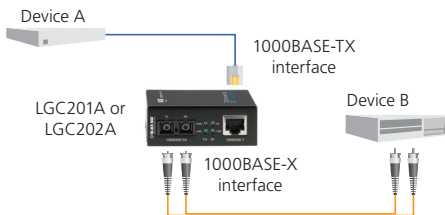

Figure 3-2. Application using one media converter.

Chapter 4: Installation

4. Installation

4.1 Typical Installation

4.1.1 LGC201A and LGC202A

1. The SC fiber connector of an LGC201A transmits/receives data by 850-nm short-wave laser on multimode fiber.
2. The SC fiber connector of an LGC202A transmits/receives data by 1310-nm short-wave laser on single-mode fiber.

Figure 4-1 shows a typical installation.

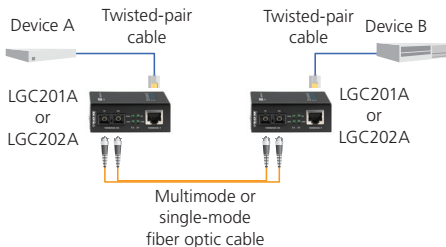

Figure 4-1. Transmits and receives data on multimode or single-mode fibers.

NOTE: The units work in pairs. You have to use either two LGC201A converters or two LGC202A converters. Or use two kinds of SFP modules, single-mode or multimode.

4.1.2 LGC200A

Plug the SFP module into the LGC200A as shown in Figure 4-2.

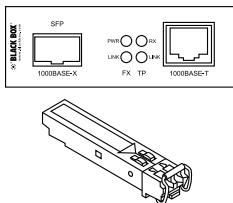

Figure 4-2. Plug the SFP module into the LGC200A.

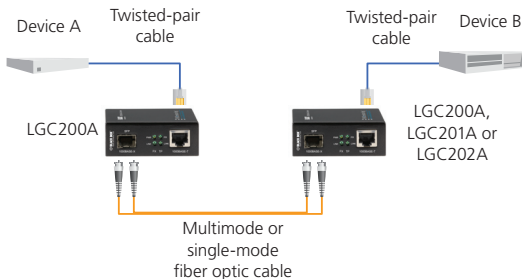

Figure 4-3. Transmits and receives data between two LGC200A converters or one LGC200A and one LGC201A/LGC202A.

NOTE: Two LGC200A with the same SFP modules can be used in pairs.

NOTE: LGC200A could be connected to LGC201A or LGC202A; however, the SFP module in the LGC200A must use the same mode and wavelength as the opposite end. The fiber connectors depend on the type of SFP installed. See Table 4-1.

Chapter 4: Installation

Table 4-1. LGC200A LC to LGC201A or LGC202A SC connection.

Part Number	LGC200A	LGC201A	LGC202A
Transmission Media	SFP module	850-nm multimode	1310-nm single-mode

4.2 Installation Procedure

Use a fiber cable to connect two converters and extend a copper link or to connect a 1000BASE-FX segment to a 1000BASE-X segment on your network.

1. Connect a converter to a 1000BASE-TX device (hub or switch).
 - Make sure that the CAT5 twisted pair cable between the 1000BASE-TX device and the converter is less than 328 feet (100) meters long.
 - Connect one end of the CAT5 twisted pair cable to the RJ-45 jack on the converter and the other end of the cable to the RJ-45 jack on the 1000BASE-TX device.
2. Connect two converters or a converter and a 1000BASE-FX device.
 - Use an SC fiber cable to connect the two converters' SC connector or the SC connector of a converter and a 1000BASE-FX device.
3. Turn on the power.

4.3 Install the Media Converter into the LHC200A-RACK

1. Take out the two screws located on the top of the chassis and use them to install the retainer as shown in Figure 4-5.

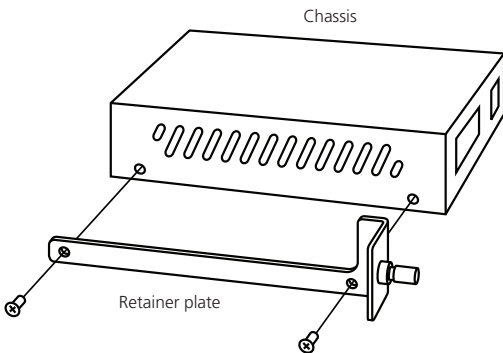

Figure 4-5. Install the retainer.

2. Turn off the switch power and take off the front guard that's on the chassis.
3. Preconfigure the media converter, then insert the media converter into the open slot of the chassis.
4. Use the locking knob to lock the media converter tightly in the chassis.

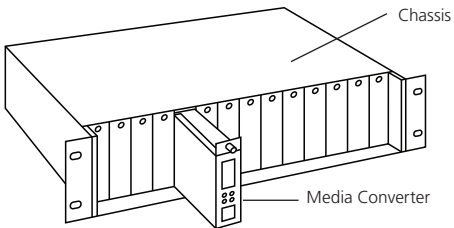

Figure 4-6. Installing a media converter into the chassis.

Chapter 4: Installation

5. Turn on the power switch and you will see the media converter's Power LED light. Then you can operate it in the same way as a standalone Pure Networking Media Converter.

5. Operation

5.1 LEDs on the Media Converters

The converters have real-time LED indicators that can provide real-time status reports. Just look at the LEDs to determine the link status. Figure 5-1 shows the LEDs, and Table 5-1 describes their functions.

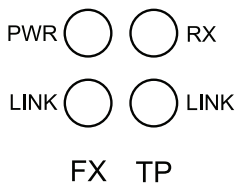

Figure 5-1. LEDs.

Chapter 5: Operation

Table 5-1. LED functions.

Name	Status	Description	
PWR	ON	Power to the chassis is ON.	
	OFF	Power to the chassis is OFF.	
FX	Link	ON	There is a valid link.
	Link	Flashing	The converter is receiving or transmitting data from the fiber optic connector.
	Link	OFF	There is no valid link.
TX	Link	ON	There is a valid link.
		Flashing	The converter is receiving or transmitting data from the TP port.
		OFF	There is no connection on the port.
	RX	ON	The TP port is connected to 1000BASE-TX.
		OFF	The TP port is not connected.

5.2 Force/Auto Switch

The DIP switch on the side of the converter sets force or autonegotiation mode.

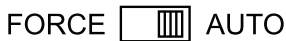

Figure 5-2. Force/Autonegotiation switch.

In a back-to-back setup, set the two converters that are on opposite ends to Force mode. When connected to other products, such as switches, set the converter to auto-negotiation mode.

6. Troubleshooting

6.1 Contacting Black Box

If you determine that your Pure Networking Gigabit Media Converter is malfunctioning, do not attempt to alter or repair the unit. It contains no user-serviceable parts. Contact Black Box Technical Support at 724-746-5500 or info@blackbox.com.

Before you do, make a record of the history of the problem. We will be able to provide more efficient and accurate assistance if you have a complete description, including:

- the nature and duration of the problem.
- when the problem occurs.
- the components involved in the problem.
- any particular application that, when used, appears to create the problem or make it worse.

6.2 Shipping and Packaging

If you need to transport or ship your Pure Networking Gigabit Media Converter:

- Package it carefully. We recommend that you use the original container.
- If you are returning the unit, make sure you include everything you received with it. Before you ship for return or repair, contact Black Box to get a Return Authorization (RA) number.

Black Box Tech Support: FREE! Live. 24/7.

Tech support the
way it should be.



Great tech support is just 30 seconds away
at 724-746-5500 or blackbox.com.



About Black Box

Black Box provides an extensive range of networking and infrastructure products. You'll find everything from cabinets and racks and power and surge protection products to media converters and Ethernet switches all supported by free, live 24/7 Tech support available in 30 seconds or less.

© Copyright 2012. Black Box Corporation. All rights reserved.

LGC200A/LGC201A/LGC202A, version 1

724-746-5500 | blackbox.com