

Ac-U-Temp

TOTAL HOT WATER SUPPLY SYSTEM USING VF™ BOILERS

**VWT-500
through
VWT-1000**

With Ac-U-Temp, A. O. Smith makes it as easy as possible to install a complete packaged hot water supply system, combining high-efficiency VF™ boilers with storage tanks up to 10,000 gallons. Each Ac-U-Temp system is custom-made to your specifications for each application and shipped fully assembled, pre-piped and pre-wired. All the installer has to do is make the flue, gas, electrical and water connections, so installations are easy.

Consult your A. O. Smith representative for more information on the wide range of available boiler/storage tank combinations using the Ac-U-Temp system.

VF MODULATING BOILERS UP TO 88% THERMAL EFFICIENCY

- A. O. Smith's most efficient hot water supply boilers
- Available inputs: 500,000, 750,000, 1,000,000 BTUs
- Flexible conventional-vent or sealed-combustion direct-vent options
- For complete information on VF Hot Water Supply Boilers, consult VF Specification Sheet

GLASS-LINED STORAGE TANKS

- Standard capacities up to 1,000 gallons
- Custom tanks available up to 10,000 gallons
- Standard tanks are factory jacketed and insulated – bare uninsulated tanks also available
- Optional cement or epoxy-lined tanks available
- For complete information on standard and optional tanks, consult tank Specification Sheet

MULTIPLE BOILER SYSTEMS

- Ac-U-Temp systems can be designed with multiple boilers to provide 50% to 100% back-up
- Multi-boiler systems can be sequenced to meet changing system demands
- Sequenced multi-boiler systems with small storage tanks are ideal for applications with relatively constant hot water demands
- Optional sequenced control panel available

MULTIPLE TANK SYSTEMS

- Ac-U-Temp systems can be designed with multiple tanks for applications with low ceiling heights or other unique installation challenges



A.O. Smith

BOILER DATA

MODEL NUMBER	INCHES OR CM	DIMENSIONS				
		LENGTH (C2)	WIDTH (C1)	HEIGHT (D)	INLET SIZE	GAS INLET
VW-500	Inches	30	30	60	2	1
	CM	76.2	76.2	152.4	5.1	2.5
VW-750	Inches	30	30	66	2	1
	CM	76.2	76.2	167.6	5.1	2.5
VW-1000	Inches	30	30	75	2	1
	CM	76.2	76.2	190.5	5.1	2.5

VERTICAL STORAGE VESSEL DATA

MODEL NUMBER	INCHES OR CM	DIMENSIONS				
		HEIGHT (A)	WIDTH (B1)	INLET HEIGHT (B2)	INLET SIZE	OUTLET SIZE
AJ-80A	Inches	66-1/4	28	15	2	2
	CM	168.3	71.1	38.1	5.1	5.1
AJV-120A	Inches	66	28	15	2	2
	CM	167.6	76.2	167.6	5.1	2.5
AJV-140A	Inches	88	30	19-1/2	2-1/2	2-1/2
	CM	223.5	76.2	49.5	6.4	6.4
AJV-200A	Inches	84	36	21	2-1/2	2-1/2
	CM	213.4	91.4	53.3	6.4	6.4
AJV-250A	Inches	96	36	21	2-1/2	2-1/2
	CM	243.8	91.4	53.3	6.4	6.4
AJV-350A	Inches	99	42	22-1/2	2-1/2	2-1/2
	CM	251.5	106.7	57.2	6.4	6.4
AJV-400A	Inches	105	42	22-1/2	2-1/2	2-1/2
	CM	233.7	106.7	57.2	6.4	6.4
AJV-500TA	Inches	101	48	24	3	3
	CM	256.5	121.9	61	6.4	6.4
AJV-500A	Inches	86	54	25-1/5	3	3
	CM	218.4	137.2	64.8	6.4	6.4
AJV-750A	Inches	118	54	24-1/2	3	3
	CM	299.7	137.2	62.2	6.4	6.4
AJV-1000A	Inches	150	54	25-1/2	3	3
	CM	381	137.2	64.8	6.4	6.4

HORIZONTAL STORAGE VESSEL DATA

MODEL NUMBER	INCHES OR CM	DIMENSIONS						
		LENGTH (A1)	OUTLET DIM (A2)	WIDTH (B1)	HEIGHT (B2)	INLET HEIGHT (B3)	INLET SIZE	OUTLET SIZE
AJH-200	Inches	77	59	36	41	11	2-1/2	2-1/2
	CM	195.6	149.9	91.4	104.1	27.9	6.4	6.4
AJH-350	Inches	93	72-1/2	42	47	14	2-1/2	2-1/2
	CM	236.2	184.2	106.7	119.4	35.6	6.4	6.4
AJH-350	Inches	99	72-1/2	42	47	14	3	3
	CM	251.5	184.2	106.7	119.4	35.6	7.6	7.6
AJH-350	Inches	94	73	48	53	14	3	3
	CM	238.8	185.4	121.9	134.6	35.6	7.6	7.6
AJH-350	Inches	79	56-1/2	54	59	14	3	3
	CM	200.7	143.5	137.2	149.9	35.6	7.6	7.6
AJH-350	Inches	111	88-1/2	54	59	14	3	3
	CM	281.9	224.8	137.2	149.9	35.6	7.6	7.6
AJH-350	Inches	143	120-1/2	54	59	14	3	3
	CM	363.2	306.1	137.2	149.9	35.6	7.6	7.6

Ac-U-Temp

TOTAL HOT WATER SUPPLY SYSTEM USING VF™ BOILERS

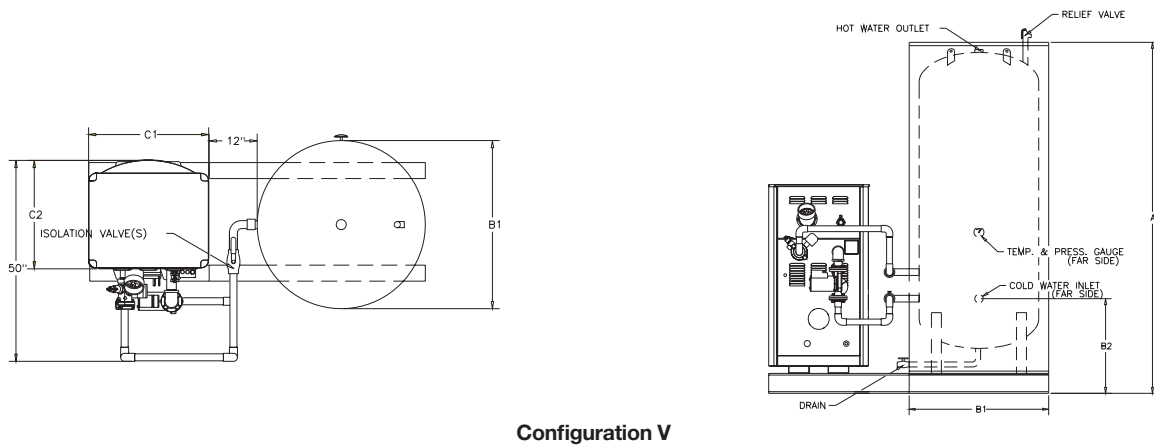
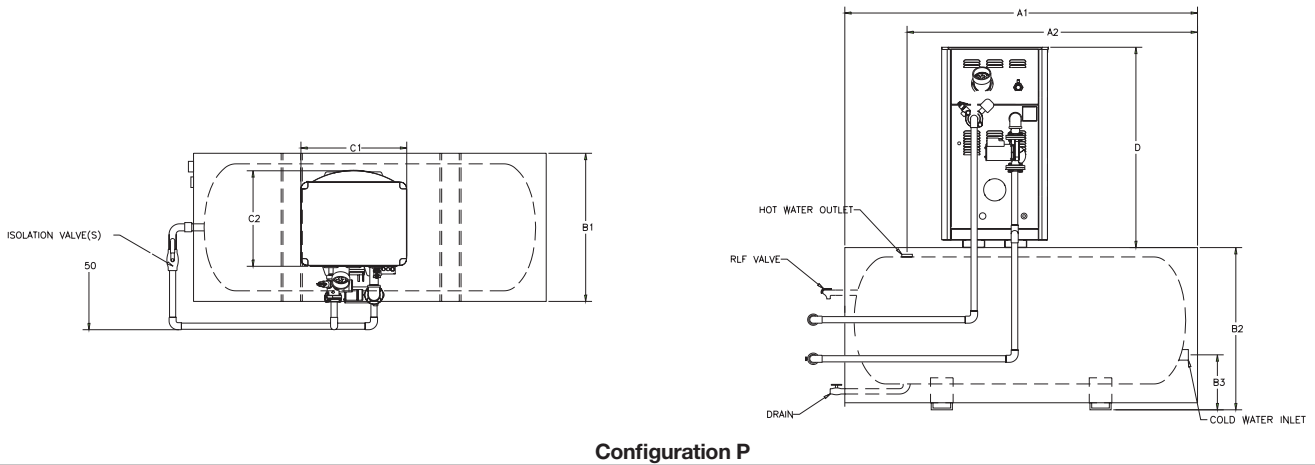
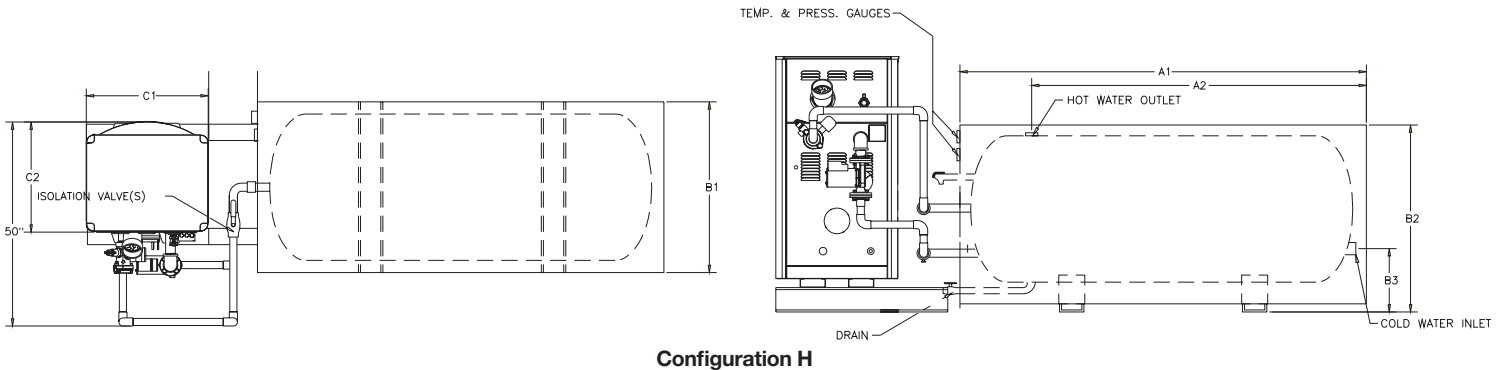

The above are standard available configurations. Custom configurations designed to your specifications are available. Contact your local A. O. Smith Sales Representative for assistance.

Ac-U-Temp

TOTAL HOT WATER SUPPLY SYSTEM USING VF™ BOILERS

DUAL-ENERGY SOURCE OPTION

- Storage tanks can be specified with an optional heat exchanger for winter heating using on-site hydronic heating boiler(s), switching to domestic hot water boiler(s) for summertime operation
- Water-to-water or steam-to-water heat exchangers available in single-wall or double-wall design
- Complete control packages can be factory-installed for "hook up and run" simplicity

PROFESSIONAL START-UP SERVICE FURNISHED

- Assures optimum performance for each installation

MEETS ASHRAE/IESNA 90.1-1999

5 YEAR VF BOILER HEAT EXCHANGER WARRANTY

5 YEAR STORAGE TANK WARRANTY

- For complete information, consult written warranty or contact A. O. Smith

OTHER FEATURES:

ASME TEMPERATURE AND PRESSURE RELIEF VALVE #125

TANK TEMPERATURE SENSOR AND THERMOMETER

ISOLATION VALVES (BALL VALVES)

125 PSI TANK WORKING PRESSURE

ALL-BRONZE CIRCULATING PUMP

LARGE SYSTEMS SHIPPED WITH SPLIT/BOLT TOGETHER SKIDS FOR EASE OF SHIPPING AND INSTALLATION

OTHER OPTIONS:

150 AND 160 PSI TANK WORKING PRESSURES

11" X 15" MANHOLES

Model to Specify:

VW T -750 - AJV - 500 A - V

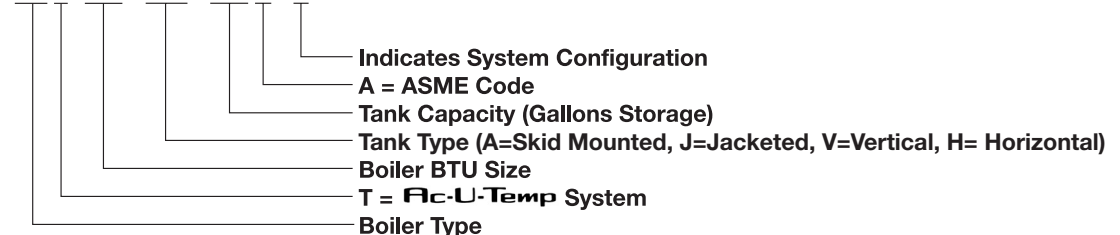

SUGGESTED SPECIFICATION

Hot Water Supply System - shall consist of A. O. SMITH Ac-U-Temp factory assembled unit Model No. _____. System shall be completely factory assembled and shall include the A.O. SMITH VF hot water supply boiler(s), with input of ____ BTU/H for (natural/propane) ____ gas and recovery capacity of _____ gph, and the A.O. SMITH glass-lined (cement/epoxy) hot water storage tank with ____ gallons capacity for _____ mounting (vertical-horizontal). System shall include properly sized circulator, inlet and outlet thermometers, tank temperature thermometer, relief valve, and tank temperature control. Entire system shall be rigidly mounted on welded steel skid base and shipped assembled to job site (Ac-U-Temp systems employing tanks too large for shipping as an assembled unit, will be shipped with the tank mounted on a split bolt-together skid). See VF Boiler Specification Sheet for boiler details. See A.O. Smith Storage Specification sheets for storage tank details.

Hot water supply boiler(s) and storage tank(s) shall have a 5 year limited warranty against corrosion as outlined in the written warranty