

ServSwitch™ BRAND
**CAT5 KVM
Micro Extender**

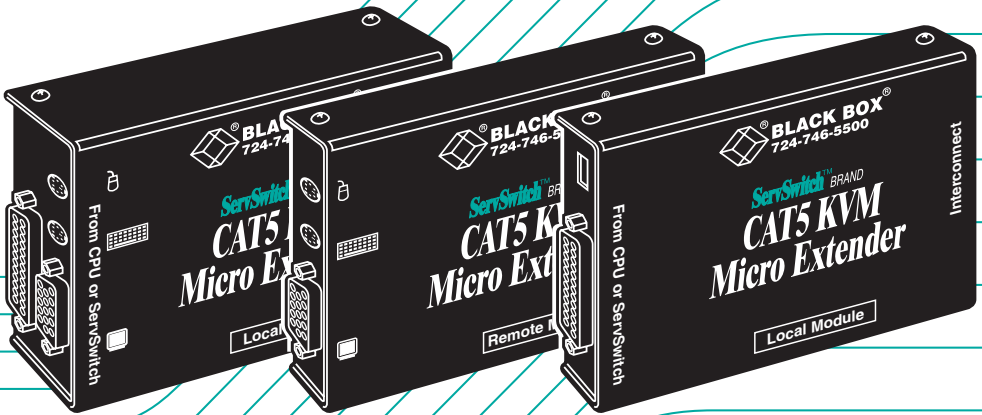

**ACU3001A
ACU3009A
ACU3022A**

Welcome to the ServSwitch™ Family!

Thank you for purchasing a BLACK BOX® ServSwitch™ Brand CAT5 KVM Extender model! We appreciate your business, and we think you'll appreciate the many ways that your enhanced keyboard/video/mouse system will save you money, time, and effort.

That's because our ServSwitch family is all about breaking away from the traditional, expensive model of computer management. You know, the one-size-fits-all-even-if-it-doesn't model that says, "One computer gets one user station, no more, no less." Why not a single user station (monitor, keyboard, and mouse) for multiple computers—even computers of different platforms? Why not a pair of user stations, each of which can control multiple computers? Why not multiple user stations for the same computer?

With our ServSwitch products, there's no reason why not. We carry a broad line of robust solutions for all these applications. Do you have just two PCs, and need an economical alternative to keeping two monitors, keyboards, and mice on your desk? Or do you need to share dozens of computers, including a mix of IBM® PC, RS/6000®, Apple® Macintosh®, Sun Microsystems®, and SGI® compatibles among multiple users with different access levels? Does your switch have to sit solidly on a worktable and use regular everyday cables? Or does it have to be mounted in an equipment rack and use convenient many-to-one cables? No matter how large or small your setup is, no matter how simple or how complex, we're confident we have a ServSwitch system that's just right for you.

The ServSwitch™ family from Black Box—the one-stop answer for all your KVM-switching needs!

*

This manual will tell you all about your new ServSwitch™ Brand CAT5 KVM Micro Extender, including how to install, operate, and troubleshoot it. For an introduction to the Micro Extender, see **Chapter 2**. The Micro Extender product codes covered in this manual are:

ACU3001A
ACU3009A
ACU3022A

TRADEMARKS USED IN THIS MANUAL

BLACK BOX and the  logo are registered trademarks, and ServSwitch, Matrix ServSwitch, ServSwitch Affinity, ServSwitch Duo, ServSwitch Multi, ServSwitch Ultra, ServSwitch Wizard, ServSwitch Wizard Pro, ServManager, ServSelect, and ServShare are trademarks, of Black Box Corporation.

Apple and Macintosh are registered trademarks of Apple Computer, Inc.

AT&T is a registered trademark of AT&T.

Pentium is a registered trademark of Intel Corporation.

IBM, PC/AT, PS/2, and RS/6000 are registered trademarks, and PC/XT is a trademark, of International Business Machines Corporation.

Microsoft, IntelliMouse, Windows, Windows Me, Windows NT, and Windows XP are registered trademarks or trademarks of Microsoft Corporation in the United States and/or other countries.

Sun Microsystems is a registered trademark of Sun Microsystems, Inc. in the United States and other countries.

Any other trademarks mentioned in this manual are acknowledged to be the property of the trademark owners.

FEDERAL COMMUNICATIONS COMMISSION AND INDUSTRY CANADA RADIO-FREQUENCY INTERFERENCE STATEMENTS

This equipment generates, uses, and can radiate radio-frequency energy, and if not installed and used properly, that is, in strict accordance with the manufacturer's instructions, may cause interference to radio communication. It has been tested and found to comply with the limits for a Class A computing device in accordance with the specifications in Subpart B of Part 15 of FCC rules, which are designed to provide reasonable protection against such interference when the equipment is operated in a commercial environment. Operation of this equipment in a residential area is likely to cause interference, in which case the user at his own expense will be required to take whatever measures may be necessary to correct the interference.

Changes or modifications not expressly approved by the party responsible for compliance could void the user's authority to operate the equipment.

Shielded cables must be used to connect this equipment to computers and peripherals in order to maintain compliance with radio frequency energy emission regulations and ensure a suitably high level of immunity to electromagnetic disturbances.

This digital apparatus does not exceed the Class A limits for radio noise emission from digital apparatus set out in the Radio Interference Regulation of Industry Canada.

Le présent appareil numérique n'émet pas de bruits radioélectriques dépassant les limites applicables aux appareils numériques de la classe A prescrites dans le Règlement sur le brouillage radioélectrique publié par Industrie Canada.

EUROPEAN UNION DECLARATION OF CONFORMITY

WARNING!

This is a class A product. In a domestic environment, this product might cause radio interference, in which case the user might be required to take adequate remedial measures.

This product complies with the following harmonized standards:

- EN55022 (1994), EN55024 (1998)
- EN61000-3-2 (1995), EN61000-3-3 (1995), EN60950 (2000)

When you use this product in environments that have high levels of electromagnetic interference, you might experience some slight disturbance in its operation. If this occurs, please refer to the Troubleshooting chapter of this manual or call technical support.

To maintain compliance, use only cables supplied (or recommended) for use with this product.



NORMAS OFICIALES MEXICANAS (NOM) ELECTRICAL SAFETY STATEMENT

INSTRUCCIONES DE SEGURIDAD

1. Todas las instrucciones de seguridad y operación deberán ser leídas antes de que el aparato eléctrico sea operado.
2. Las instrucciones de seguridad y operación deberán ser guardadas para referencia futura.
3. Todas las advertencias en el aparato eléctrico y en sus instrucciones de operación deben ser respetadas.
4. Todas las instrucciones de operación y uso deben ser seguidas.
5. El aparato eléctrico no deberá ser usado cerca del agua—por ejemplo, cerca de la tina de baño, lavabo, sótano mojado o cerca de una alberca, etc.
6. El aparato eléctrico debe ser usado únicamente con carritos o pedestales que sean recomendados por el fabricante.
7. El aparato eléctrico debe ser montado a la pared o al techo sólo como sea recomendado por el fabricante.
8. Servicio—El usuario no debe intentar dar servicio al equipo eléctrico más allá a lo descrito en las instrucciones de operación. Todo otro servicio deberá ser referido a personal de servicio calificado.
9. El aparato eléctrico debe ser situado de tal manera que su posición no interfiera su uso. La colocación del aparato eléctrico sobre una cama, sofá, alfombra o superficie similar puede bloquea la ventilación, no se debe colocar en libreros o gabinetes que impidan el flujo de aire por los orificios de ventilación.
10. El equipo eléctrico deber ser situado fuera del alcance de fuentes de calor como radiadores, registros de calor, estufas u otros aparatos (incluyendo amplificadores) que producen calor.
11. El aparato eléctrico deberá ser conectado a una fuente de poder sólo del tipo descrito en el instructivo de operación, o como se indique en el aparato.

12. Precaución debe ser tomada de tal manera que la tierra física y la polarización del equipo no sea eliminada.
13. Los cables de la fuente de poder deben ser guiados de tal manera que no sean pisados ni pellizcados por objetos colocados sobre o contra ellos, poniendo particular atención a los contactos y receptáculos donde salen del aparato.
14. El equipo eléctrico debe ser limpiado únicamente de acuerdo a las recomendaciones del fabricante.
15. En caso de existir, una antena externa deberá ser localizada lejos de las líneas de energía.
16. El cable de corriente deberá ser desconectado del cuando el equipo no sea usado por un largo periodo de tiempo.
17. Cuidado debe ser tomado de tal manera que objetos líquidos no sean derramados sobre la cubierta u orificios de ventilación.
18. Servicio por personal calificado deberá ser provisto cuando:
 - A: El cable de poder o el contacto ha sido dañado; u
 - B: Objetos han caído o líquido ha sido derramado dentro del aparato; o
 - C: El aparato ha sido expuesto a la lluvia; o
 - D: El aparato parece no operar normalmente o muestra un cambio en su desempeño; o
 - E: El aparato ha sido tirado o su cubierta ha sido dañada.

Contents

| Chapter | Page |
|-----------------------------------------------------------------------------------------------------------------------------------|-------------|
| 1. Quick Start Guide | 9 |
| 2. Specifications | 10 |
| 3. Introduction | 14 |
| 3.1 Compatibility | 15 |
| 3.2 Key Features | 17 |
| 4. Checklist of System Components | 18 |
| 4.1 The Complete Package | 18 |
| 4.2 The Cables You'll Need | 19 |
| 4.2.1 To Connect a CPU to the Local Unit | 19 |
| 4.2.2 To Connect a ServSwitch Family KVM Switch to the Local Unit's CPU Port | 20 |
| 4.2.3 To Connect a Monitor, Keyboard, and Mouse to the Remote Unit or to the User Ports on the Dual-Access Local Unit | 22 |
| 4.2.4 To Connect a ServSwitch Family KVM Switch to the Remote Unit or to the User Ports on the Dual-Access Local Unit | 23 |
| 4.2.5 To Connect the Local Unit to the Remote Unit | 25 |
| 5. Configuration | 26 |
| 5.1 Setting DIP-Switch Position 1: Video Distance | 26 |
| 5.2 Setting DIP-Switch Position 2: Keyboard-Command Recognition .. | 27 |
| 5.3 Setting the Microphone-Amplification Jumper in the KVM/Serial/Audio Remote Unit (Not Normally Necessary) | 28 |
| 6. Installation | 29 |
| 6.1 Test-Placing the Extender System (Optional) | 29 |
| 6.2 Attaching Devices | 29 |
| 6.2.1 Special Concerns About Connecting Audio Devices to the KVM/Serial/Audio Micro Extender | 31 |
| 6.2.2 Attaching a CPU to the Local Unit's CPU Port | 32 |
| 6.2.3 Attaching a ServSwitch Family KVM Switch to the Local Unit's CPU Port | 33 |
| 6.2.4 Attaching User-Station Equipment to the User Port on a Remote Unit or Dual-Access Local Unit | 36 |
| 6.2.5 Attaching a ServSwitch Family KVM Switch to the User Port on a Remote Unit or Dual-Access Local Unit | 37 |

Contents (continued)

| Chapter | Page |
|---------------------------------------------------------------------------|------|
| 6. Installation (continued) | |
| 6.3 Finishing Your Installation | 40 |
| 7. Operation | 42 |
| 7.1 Keyboard and Mouse Emulation | 42 |
| 7.2 Normal Operation and Keyboard Typematic Rate | 42 |
| 7.3 Keyboard Commands and Related Functions | 43 |
| 7.3.1 Resetting the Keyboard and Mouse | 43 |
| 7.3.2 Correcting the PS/2 Mouse If It Gets Out of Sync | 44 |
| 7.3.3 The Inactivity Timeout (ACU3009A Dual-Access Systems Only) | 45 |
| 7.3.4 Private Mode (ACU3009A Dual-Access Systems Only) | 46 |
| 8. Troubleshooting | 47 |
| 8.1 Common Problems | 47 |
| 8.1.1 Keyboard | 47 |
| 8.1.2 Mouse | 48 |
| 8.1.3 Both Keyboard and Mouse | 49 |
| 8.1.4 Serial Device (ACU3022A KVM/Serial/Audio Systems Only) | 50 |
| 8.1.5 Audio Devices (ACU3022A KVM/Serial/Audio Systems Only) | 51 |
| 8.1.6 Video | 51 |
| 8.1.7 Power | 53 |
| 8.2 General Questions About the Micro Extender | 54 |
| 8.3 Calling Black Box | 56 |
| 8.4 Shipping and Packaging | 56 |
| Appendix A: Cable Pinning/Pairing | 57 |
| Appendix B: Keyboard-Command Summary | 58 |

1. Quick Start Guide

When you *configure* the ServSwitch™ Brand CAT5 KVM Micro Extender, you only need to answer two questions:

- How far will the CAT5 cabling run between the Extender's Local and Remote Units? If it will be 25 m (80 ft.) or less, you don't need to set anything. If it will be 25 to 50 m (80 to 160 ft.), move DIP-switch position 1 on the bottom of the Remote Unit to the DOWN (ON) setting.
- *ACU3001A or ACU3009A*: Do you need [Scroll Lock] for anything?
ACU3022A: Do you need right-[Ctrl] for anything?

If not, you can use this key to command the Extender, and you don't need to set anything. If you need this key to control your hardware or software, or if your keyboard doesn't have this key, move DIP-switch position 2 on the bottom of the Remote Unit to the DOWN (ON) setting.

To *install* your Extender system, refer to the illustration below. The elements of a basic ACU3001A Single-Access installation are shown with solid lines; extra elements that can be present in an ACU3009A Dual-Access or an ACU3022A KVM/Serial/Audio installation are shown with dashed lines.

Use the included extension cable to attach the CPU to the Local Unit. Plug the remote keyboard, monitor, and mouse directly into the Remote Unit. In Dual-Access systems, plug the local keyboard, monitor, and mouse directly into the Local Unit. Connect the Local and Remote Units with straight-pinned four-pair solid-core CAT5 cable (*not* Level 6, etc.). Power the Remote Unit with its included power supply. For more information, or if your installation includes any KVM switches, refer to **Chapter 6**.

**Local monitor, keyboard, and mouse
(ACU3009A Dual-Access systems only)**

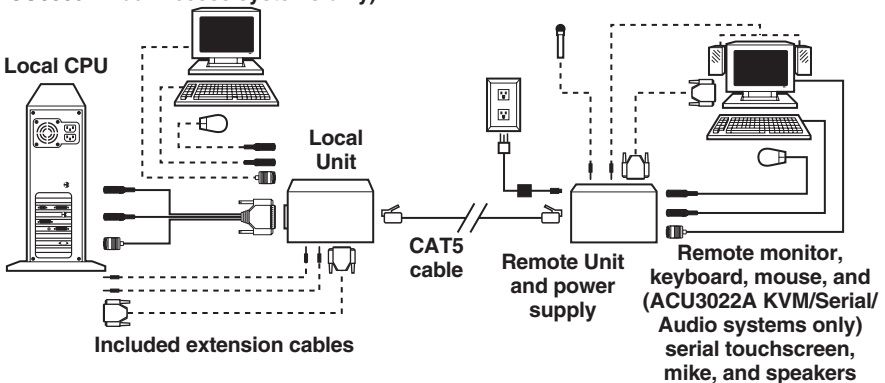

2. Specifications

- Cable Required:** Between Local and Remote Units: Category 5 solid unshielded or shielded twisted pair (UTP or STP), wired to the EIA/TIA-568A or (preferred) -568B standard, terminated with RJ-45 male connectors; for pinning/pairing, see **Appendix A**
- Compliance:** CE class A; FCC Part 15 Subpart B Class A, IC Class/classe A
- Compatibility:** Video: VGA, SVGA, XGA, XGA-2, or RGsB (sync on green), although if your system has monitor ID-bit requirements, you might need to call Black Box for technical support;
Keyboard: IBM PC/AT or PS/2 compatible (PC/AT types require connector adapter);
Mouse: IBM PS/2 compatible two-button, Microsoft IntelliMouse, or Logitech PS/2 compatible 3-button
- Interfaces:** On all models:
To monitor: VGA;
To keyboard and mouse: IBM PS/2 compatible;
To CPU's video, keyboard, and mouse ports:
Proprietary composite of VGA video and IBM PS/2 compatible keyboard and mouse;
Between Units: Proprietary composite of all supported device interfaces;
On KVM/Serial/Audio model (ACU3022A) only:
To serial device: EIA/TIA RS-232 pinned according to TIA-574, DTE;
To CPU's serial port: EIA/TIA RS-232 pinned according to TIA-574, DCE;
To audio devices and CPU's audio ports: Bidirectional 3.5-mm mini stereo audio
- Video Characteristics:** Resolution: Up to 1280 x 1024;
I/O signal levels: 0.7 volts peak-to-peak;
Compensation: For short- or long-distance (user-switchable);
Synchronization: H/V or composite, TTL signal levels; sync polarity is preserved;
Coupling: DC

Serial

Characteristics: KVM/Serial/Audio model (ACU3022A) only:
 Data rate: Transparent to data rates up to 19,200 bps;
 Data format: Transparent to data format;
 Flow control: Transparent to hardware and software flow control (RTS, CTS, DTR, and DSR are all passed through across the link)

Audio

Characteristics: KVM/Serial/Audio model (ACU3022A) only:
 Signal format: Digitized at almost CD quality (16-bit sampling at 38.4 kHz);
 Signal levels: Line level (5 volts peak-to-peak maximum);
 Input impedance: 47 k Ω ;
 Signal direction: Simultaneous bidirectional;
 Extra microphone support at Remote Unit: Pull-up resistor provides bias for condenser microphone; optional amplification to +17 dB for external microphone

Maximum

Distance: 5 m (16 ft.) from the Local Unit to the attached local equipment;
 5 m (16 ft.) from the Remote Unit to the attached remote equipment;
 50 m (160 ft.) between Local and Remote Units

NOTE

With high-quality cables, it might be possible to run farther than 5 m (16 ft.) from the Extender to attached equipment.

User Controls: Keyboard commands (see **Section 7.3** and **Appendix B**);
 On Remote Unit: Bottom-mounted 2-position DIP switch for video distance (cable length) and keyboard-command recognition

Indicator: On Local Unit: Right-side-mounted LED for power and link integrity

Connectors:**On Local Unit:**

Right-side-mounted: (1) RJ-45 female for local/remote interconnection;

Left-side-mounted:

All models: (1) DB25 female for video input from, and keyboard/mouse output to, computer;

Dual-Access model (ACU3009A) only:

(1) HD15 female for video output to local monitor;

(2) 6-pin mini-DIN female for input from local keyboard and mouse;

KVM/Serial/Audio model (ACU3022A) only:

(1) DB9 female for serial I/O to and from local RS-232 device;

(2) 3.5-mm mini stereo jacks for audio I/O to and from local device(s): (1) for audio in (usually speaker/headphone signals), (1) for audio out (usually microphone signals);

On Remote Unit:**Right-side-mounted:**

(1) RJ-45 female for local/remote interconnection;

(1) 2.5-mm center-positive barrel jack for power;

Left-side-mounted:

(1) HD15 female for video output to monitor;

(2) 6-pin mini-DIN female for input from keyboard and mouse;

KVM/Serial/Audio model (ACU3022A) only:

(1) DB9 male for serial I/O to and from remote RS-232 device;

(2) 3.5-mm mini stereo jacks for audio I/O to and from remote device(s): (1) for audio in (usually from a microphone), (1) for audio out (usually to speakers or headphones)

Temperature

Tolerance: 32 to 104°F (0 to 40°C)

Humidity

Tolerance: 5 to 90% noncondensing

Enclosure:

Steel

Power:

Local Unit:

5 VDC at up to 120 mA from CPU's keyboard and mouse port;

Remote Unit:

From desktop power supply (certified to meet the relevant international safety standards):

Input: 100 to 240 VAC at 50 to 60 Hz from utility-power (mains) outlet, through detachable power cord and IEC 320 male inlet, to external transformer;

Output (isolated from mains ground): 9 VDC regulated, at up to 1 amp, from transformer to Remote Unit

CAUTION!

If you ever need to replace the Remote Unit's power supply, the replacement power supply must have identical output characteristics. Using a power supply with different output—even if it's "almost the same"—could damage your Remote Unit and the attached equipment.

Size:

Each Unit:

Height:

ACU3001A Units, ACU3009A Remote Unit:

1" (2.5 cm);

ACU3022A Units, ACU3009A Local Unit:

1.7" (4.3 cm);

Feet protrude an additional 0.1" (0.2 cm) from bottom;

Width: 4.3" (11 cm); D-shell connectors protrude an additional 0.1" (0.2 cm) from left side;

Depth: 3.2" (8.2 cm); additionally, screws protrude less than 0.1" (0.2 cm) from both the front and the back

Weight:

ACU3001A Units, ACU3009A Remote Unit:

8.3 oz. (235 g);

ACU3009A Local Unit: 13.5 oz. (380 g);

ACU3022A Units: 18 oz. (510 g)

3. Introduction

By using the Local and Remote Units that together make up the ServSwitch™ Brand CAT5 KVM or KVM/Serial/Audio Micro Extender, you can place your VGA monitor, keyboard, and mouse as far as 50 meters (160 ft.) from the PC-compatible CPUs they communicate with.

The Single-Access (ACU3001A) model of the Extender is designed to perform KVM extension only. With the Dual-Access (ACU3009A) model, you can attach an additional monitor, keyboard, and mouse to the Local Unit; the PC can then be operated from either the local or remote user station (they share access on a “first-come, first-served” basis—see **Section 7.3.3**). The KVM/Serial/Audio (ACU3022A) model has all of the capabilities of the regular Single-Access version, and can also support a connection between the PC and a remote serial device, plus a connection between the PC and a remote microphone and speakers (or other sources of audio input and output).

IMPORTANT NOTES

Throughout this manual, serial and audio devices/connections/etc. will often be listed without qualification along with video/monitor, keyboard, and mouse devices/connections/etc. Just keep in mind that, except where noted, all references to serial or audio communication apply to KVM/Serial/Audio Micro Extender systems only.

Also, do *not* connect a KVM Micro Local Unit to a KVM/Serial/Audio Micro Remote Unit, or a KVM/Serial/Audio Micro Local Unit to a KVM Micro Remote Unit. Extender systems with intermixed KVM Micro and KVM/Serial/Audio Micro equipment *do not work*.

The Local and Remote Units are designed to be interconnected with a single industry-standard Category 5 UTP or STP 4-pair cable. All keyboard, mouse, and video signals are fully buffered to ensure consistent remote operation of your PC.

The Micro Extender is simple to operate and works with all operating systems—no software is required. Once you’ve made sure you have everything you’ll need (see **Chapter 4**) and you’ve configured your Local and Remote Units (see **Chapter 5**), just connect the Local and Remote Units to each other and to your equipment as described in **Chapter 6** and you’re ready to work!

Because the Micro Extender performs complete PS/2® keyboard and mouse emulation, you can boot the PC without having a keyboard or mouse attached to it. Your PC will boot even if the Extender’s Remote Unit is not powered or has no keyboard or mouse connected to it.

3.1 Compatibility

The ServSwitch Brand CAT5 KVM Micro Extender is designed to operate in various environments and with a mix of hardware from different manufacturers. During development, this product was extensively tested with a wide variety of hardware. However, please note that it is impossible for us to guarantee that the Micro Extender will interoperate correctly with every keyboard, mouse, monitor, motherboard variant, and RS-232 device currently on the market. If you suspect that you're having incompatibility problems, please call Black Box Technical Support.

In general, the Micro Extender is compatible with the following types of equipment:

- **CPU:** IBM® PC/AT®, PS/2, and 100% compatible clones. These should be desktop machines; laptops and docking stations are not supported.
- **Monitor:** VGA, SVGA, XGA, XGA-2, or RGsB (sync on green). Be aware that a few monitors and graphics cards might not work with the “as is” Micro Extender—at least in their factory-default settings—because they exchange monitor IDs or VESA DDC (Display Data Channel) information. Call Black Box Technical Support for help with “ID bit” problems. As for DDC, the Extender supports it at the ACU3009A's local user station but not at any remote user station, so either (a) do not use a DDC monitor at your remote station, or (b) go into your graphics card's settings, turn DDC off, and manually configure the card for your monitor(s).
- **Keyboard:** Standard (101- or 102-key) PS/2 type or enhanced PS/2 type (104- or 105-key, designed for use with versions of Windows® starting with Windows 95). Although we don't recommend this, you might also be able to use a PC/AT type keyboard with 5-pin DIN connectors; you'll need adapters to attach it and its native CPU to the Micro Extender (see the start of **Section 4.2**). Some older PC/XT™ or PC/AT type autosensing keyboards might not be compatible with the Extender. If the keyboard you want to use is some other type or has some other type of connector, call Black Box for technical support.

For information about keyboard typematic support, see **Section 7.2**.

- **Mouse:** Standard PS/2 type, Microsoft® IntelliMouse® compatible, or Logitech™ 3-button PS/2 compatible mouse; the CPU should have standard PS/2 type mouse ports. The KVM/Serial/Audio Micro Extender can handle a serial mouse if it's attached to the Remote Unit's serial port, but the other models are *not* compatible with serial mice and require adapters to support PCs with PC/AT type serial mouse ports—see the Note below. The Micro Extenders are *not* compatible at all with bus mice or CPUs with bus-mouse ports. If a mouse or mouse port you want to attach is some other type or has some other type of connector, call Black Box Technical Support.
- **Serial Device (KVM/Serial/Audio Micro Extenders only):** Standard asynchronous RS-232 devices, including serial mice and trackballs, that operate at up to 19,200 bps and don't require any hardware control signals other than RTS, CTS, DSR, and DTR. (The Micro Extender is transparent to data format and to all data rates up to 19,200 bps. It passes the control signals through.)

NOTE

The Extenders do not support serial mice on their PS/2 mouse ports. The KVM/Serial/Audio Micro Extender supports a serial mouse on its Remote Unit's serial port without requiring any special configuration.

- **Audio Device (KVM/Serial/Audio Micro Extenders only):** Just about any standard PC sound card or consumer audio device that doesn't transmit or receive signals at voltages above line level (5 volts peak-to-peak) should be compatible with the Micro Extender.

3.2 Key Features

The ServSwitch Brand CAT5 KVM Micro Extender has a number of useful features which contribute to the transparent remote operation of your PC. Some of the more important ones are:

- **Distance up to 50 m (160 ft.)**
Operate your PC from the next room or all the way down the hall.
- **Adjustable video equalization**
Compensates for the loss of image quality caused by the signal passing through more than 25 m (80 ft.) of cable.
- **Fully buffered signals**
Remote operation of the PC is consistently smooth and transparent.
- **Intelligent PS/2 keyboard and mouse emulation**
With this, the PC boots and operates correctly under most circumstances, and you can freely detach and reconnect the keyboard and mouse as necessary (the Micro Extender automatically initializes the keyboard and mouse as soon as it detects that you've reattached them).
- **Microsoft IntelliMouse compatibility**
Use this and compatible "wheel mice" with confidence. In a Dual-Access (ACU3009A) system, you can even use a standard PS/2 mouse at one of the PC's user stations and an IntelliMouse at the other.
- **Dual-Access model also supports a local station**
With the Dual-Access (ACU3009A) model, you can operate the PC either locally or remotely (but not both at the same time).
- **KVM/Serial/Audio systems only: Support for serial and audio peripherals**
With the KVM/Serial/Audio Micro Extender (ACU3022A), you can connect almost any RS-232 device that can communicate at 19,200 bps or less, as well as almost any standard audio device or sound card.

We recommend that you read the remainder of this manual before you install the Micro Extender in order to fully familiarize yourself with the system.

4. Checklist of System Components

4.1 The Complete Package

At the time of this writing, these items should be included with your ServSwitch™ Brand CAT5 KVM Micro Extender package:

- (1) Micro Extender Local Unit.
- (1) Micro Extender Remote Unit.
- (1) 9-VDC 1-amp power-supply transformer and output cord.
- (1) Power-supply input cord suitable for your country or region.
- (1) 3.6-ft. (1.1-m) KVM-extension cable (runs from PC CPU to Local Unit) with a DB25 male connector at the Unit end and an HD15 male connector and two 6-pin mini-DIN male connectors at the CPU end. The 6-pin mini-DIN connectors are attached to the HD15 by additional 16" (40-cm) cable strands. (If your PC has 5-pin DIN keyboard connectors, see the start of **Section 4.2** for how you'll connect it.)
- (1) Copy of this manual.

The KVM/Serial/Audio Micro Extender should also include these extension cables that run from the CPU to the Local Unit:

- (1) 6-ft. (1.8-m) DB9 female to DB9 male serial-extension cable.
- (2) 6-ft. (1.8-m) audio-extension cables with 3.5-mm stereo plugs on either end.

The components of the Extender package are, however, subject to change without notice.

Please contact Black Box right away if any of these items are damaged when you receive them.

4.2 The Cables You'll Need

If you are using the ServSwitch™ Brand CAT5 KVM Micro Extender to get greater distance between a CPU and a VGA monitor, PS/2 keyboard, and PS/2 mouse, your Micro Extender package should have included everything you'll need except for your Unit-interconnection cable. Read **Sections 4.2.1, 4.2.3, and 4.2.5** carefully, then skip ahead to **Chapter 5**.

If you are using the Micro Extender to get greater distance between a ServSwitch family KVM switch and a CPU, a user station (monitor/keyboard/mouse), or a compatible switch, you might need additional non-included cabling. Read the relevant sections on the next few pages, from **Section 4.2.1** through **Section 4.2.5**.

NOTE

When you order any cable listed in this section, you will be asked to specify the length you want. Some cables might be available in a few stock lengths only.

If you are using any equipment with PC/AT style connectors, you might also need some combination of these adapters:

- To attach a CPU or KVM switch with a 5-pin DIN female keyboard connector to the Local Unit: A keyboard-port adapter such as product code FA211.
- *All except the KVM/Serial/Audio model:* To attach a CPU or KVM switch with an RS-232 serial DB9 male mouse connector to the Local Unit: A mouse-port adapter such as product code AC244A. (If the mouse port is DB25 rather than DB9, you'll also need an FA521A serial adapter.)
- To attach a keyboard or KVM switch with a 5-pin DIN male keyboard connector to the Remote Unit or Dual-Access Local Unit: A keyboard adapter such as product code FA212.

4.2.1 TO CONNECT A CPU TO THE LOCAL UNIT

You'll use the three-in-one KVM-extension cable included with the Extender to connect the Local Unit's DB25 composite port to the CPU's keyboard, mouse, and video ports. As mentioned above, you might also need port adapters if your CPU has PC/AT type ports.

To attach the DB9 serial port and the 3.5-mm audio ports of a KVM/Serial/Audio Local Unit to the CPU's serial and audio ports, you'll use the DB9 male-to-female serial-extension cable and the 3.5-mm stereo audio-extension cables included with the Extender.

4.2.2 TO CONNECT A SERVSWITCH FAMILY KVM SWITCH TO THE LOCAL UNIT'S CPU PORT

You would do this to extend the distance you can run from the KVM switch to a monitor, a keyboard, a mouse, and possibly serial and/or audio devices. (You could also do this to extend the distance you can run between two cascaded switches, but for this to work, each switch *must* be either a ServSwitch Jr. or one of the ServSwitch family models with DB25 composite interfaces listed in **Section 4.2.2.B.**)

The Local Unit's CPU port is the DB25 connector on the opposite end of the Unit from the RJ-45 jack. Which cable(s) you'll use to connect the switch to it will depend on what type of user ports the switch model has, as detailed in the following three subsections.

4.2.2.A Switches Whose User Ports Are a Set of Separate Interfaces

The user ports of some ServSwitch family KVM switches are a set of separate interfaces: Each user port consists of separate interfaces/connectors for video, keyboard, and mouse communication. At the time of this writing, some of the important ServSwitch family models in this category are:

- ServSwitch™ Duo
- ServSwitch™ Wizard, Wizard LP, Wizard MP, and Wizard Pro
- ServSwitch™ Jr.
- Personal ServSwitch™
- ServSelect™
- ServSwitch™ Multi Base Unit ("local console" user port only)

To attach a user port on one of these switches to the Local Unit's CPU port, you can use the three-in-one KVM-extension cable included with the Extender. If the user port is a console port on a ServSwitch Multi and the Extender is a KVM/Serial/Audio model, you might also need to use the DB9 male-to-female serial-extension cable and/or 3.5-mm male-to-male audio-extension cables included with the Extender.

4.2.2.B Switches with DB25 Composite User Ports

The user ports of some ServSwitch family KVM switches are specially pinned DB25 connectors that function as composite (all-in-one) interfaces. At the time of this writing, some of the important ServSwitch family models in this category are:

- ServSwitch™
- ServSwitch™ Ultra
- Matrix ServSwitch™
- ServSwitch™ Affinity
- ServShare™

You'll need a ServSwitch-to-ServSwitch Expansion Cable (product code EHN284) to attach this type of KVM-switch user port to the Local Unit's CPU port.

4.2.2.C ServSwitch Multi (HD62 Composite User Ports)

The user ports on User Cards installed in the ServSwitch Multi are HD62 female connectors that function as composite (all-in-one) interfaces. To attach one of these ports to the CPU port of a Local Unit, first you'll need to connect the three-to-one KVM-extension cable included with the Extender to the DB25 connector of the Local Unit's CPU port. (If you're doing serial and/or audio extension through a KVM/Serial/Audio model, you'll also need to connect the DB9 male-to-female serial-extension cable and/or the 3.5-mm male-to-male audio-extension cables included with the Extender to the matching connectors of the Local Unit's CPU port.)

Once you have one end of the included cable(s) connected to the Local Unit, run a many-to-one ServSwitch Multi User Cable such as product code KV2505 (for just KVM extension) or KV2515 (for KVM, serial, and/or audio extension) from the other ends of the included cable(s) to the user port of the ServSwitch Multi. Refer to **Section 6.2.3.B** for a description of how this cabling all fits together.

4.2.3 TO CONNECT A MONITOR, KEYBOARD, AND MOUSE TO THE REMOTE UNIT OR TO THE USER PORTS ON THE DUAL-ACCESS LOCAL UNIT

You'll be plugging the monitor, keyboard, and mouse directly into the corresponding user ports on the Remote Unit or Dual-Access Local Unit. If your touchscreen or other serial device is made to plug directly into a CPU, it will plug directly into the serial connector of the KVM/Serial/Audio Remote Unit; if not, you will need a serial cable to attach the device:

- If the serial device is DCE and has a DB25 female connector, use a DB9 female to DB25 male modem cable such as product code EVMBMC.
- If the serial device is DTE and has a DB25 female connector, use a DB9 female to DB25 male null-modem cable such as EVMBPC.
- If the serial device is DTE and has a DB25 male connector, use a DB9 female to DB25 female null-modem cable such as BC01900.
- If the serial device is DTE and has a DB9 male connector, use a DB9 female to DB9 female null-modem cable such as EYN257H.

NOTE

KVM/Serial/Audio Extender systems only: Because the KVM/Serial/Audio Extender transparently passes through RTS, CTS, DTR, and DSR, it is possible to substitute additional TD/RD data pairs (to/from a second or third serial device) for each pair of these hardware flow-control signals if you're using software flow control (or no flow control) instead. To do this, you'll need to attach special breakout cables to the Extender's serial ports. Call Black Box Technical Support if you'd like to do this.

If your audio device is made to plug directly into a CPU, it will plug directly into the KVM/Serial/Audio Remote Unit; if not, you will need an audio cable such as product code EJ110-0010 to attach the device.

4.2.4 TO CONNECT A SERVSWITCH FAMILY KVM SWITCH TO THE REMOTE UNIT OR TO THE USER PORTS ON THE DUAL-ACCESS LOCAL UNIT

You would do this to extend the distance you can run from the KVM switch to a CPU. (You could also do this to extend the distance you can run between two cascaded switches, but for this to work, each switch *must* be one of the ServSwitch family models with regular ServSwitch style DB25 composite interfaces listed in **Section 4.2.4.B.**)

On the Remote Unit and the Dual-Access Local Unit, the user ports are the HD15 and 6-pin mini-DIN connectors on the opposite end of the Unit from the RJ-45 jack. Which cable(s) you'll use to connect the switch to it will depend on what type of CPU ports the switch model has, as detailed in the following three subsections.

4.2.4.A Switches Whose CPU Ports Are a Set of Separate Interfaces

The CPU ports of some ServSwitch family KVM switches are a set of separate interfaces: Each CPU port consists of separate interfaces/connectors for video, keyboard, and mouse communication. At the time of this writing, some of the important ServSwitch family models in this category are:

- ServSwitch™ Duo
- ServSwitch™ Wizard, Wizard LP, Wizard MP, and Wizard Pro
- Personal ServSwitch™

You'll need individual keyboard-, video-, and mouse-extension cables (such as product codes EVMPS03-MM for keyboard and mouse, EVNPS05-MM for video) or a specially bonded three-to-three CPU-extension cable (product code EHN408) to attach a KVM-switch CPU port of this type to the user ports on the Remote Unit or Dual-Access Local Unit.

4.2.4.B Switches with Regular ServSwitch Style DB25 Composite CPU Ports

The CPU ports of the regular ServSwitch and several other ServSwitch family KVM switches are specially pinned DB25 connectors that function as composite (all-in-one) interfaces. At the time of this writing, some of the other important ServSwitch family models in this category are:

- ServSwitch™
- ServSwitch™ Ultra
- Matrix ServSwitch™
- ServSwitch™ Affinity
- ServSwitch Jr.
- ServShare™

(**Note:** The ServSelect also has DB25 composite CPU ports, but they are pinned differently. See **Section 4.2.4.C.**)

You can use the three-to-one KVM-extension cable included with your Extender to attach a KVM-switch CPU port of this type to the user ports on the Remote Unit or Dual-Access Local Unit. If you've already used that cable to attach a CPU to the Local Unit, order the same type of cable (product code EHN230) to make this connection.

4.2.4.C Switches with Other Types of Composite CPU Ports

The CPU ports of some ServSwitch family KVM switches are composite (all-in-one) interfaces that are not the same as those on the regular ServSwitch, but the principle for connecting them is the same:

- The CPU ports on the CPU Cards of the ServSwitch Multi are HD44 female connectors. You'll need a ServSwitch Multi Server Cable such as product code KV2020-R2 (for just KVM extension) or KV2040-R2 (for KVM, serial, and/or audio extension) to attach a ServSwitch Multi CPU port to the user ports on the Remote Unit or Dual-Access Local Unit.
- The CPU ports on the ServSelect are DB25 connectors pinned *differently from* the DB25 connectors on the regular ServSwitch. You'll need a ServSelect Cable (product code EHN056) to attach a ServSelect CPU port to the user ports on the Remote Unit or Dual-Access Local Unit.

4.2.5 TO CONNECT THE LOCAL UNIT TO THE REMOTE UNIT

To interconnect the Local and Remote Units of the Micro Extender, you'll need industry-standard structured cabling (Category 5 UTP or STP, 4-pair) terminated with RJ-45 plugs. This cable is not included with the Extender. You'll need CAT5 patch cables such as our product code EYN737MS or CAT5 bulk cable such as our EYN840A. The bulk cable should be terminated with high-quality RJ-45 plugs such as those included in our FM732 25-pack.

CAUTION!

This cable *must* be solid-core type; stranded patch cable will give poor results over longer distances. The pairing of the cable and pinning of its connectors must be in accordance with EIA/TIA-568A or (preferably) EIA/TIA-568B. (Refer to the wiring chart in Appendix A. Please note that failure to wire the twisted pairs correctly will dramatically impair video quality and possibly prevent correct operation.)

Regular CAT5 is preferable to CAT5e cable (rated for 155 Mbps), although CAT5e should perform well in most applications. *Avoid* using "Level 6" or "Level 7" cables, or other types of cable rated for data rates higher than 100 Mbps (bandwidths higher than 100 MHz). This is because the wires in these cables are twisted much more tightly than those in regular CAT5, which is great for high-speed data but *really bad* for analog video signals. Having said that, however, the signal-skew problems caused by tightly twisted pairs in these cables can sometimes be resolved by swapping which pairs are used for which signals or by using an external delay line. Please contact tech support if you have problems getting a good picture with CAT5e cable or if you *must* use cables with bandwidths higher than 155 Mbps.

Even though your network might use the same type of 4-wire twisted-pair cabling, do *not* connect the Micro Extender to 10/100BASE-T Ethernet devices or *any* other network equipment. Doing so will virtually destroy the Extender's circuitry and could also damage the attached equipment.

The Micro Extender is designed for use up to a maximum cable length of 50 m (160 ft.). At this length the video quality should be acceptable even at a screen resolution of 1280 x 1024 pixels.

Although a single continuous length of interconnect cable is preferable, it's possible to operate a Micro Extender system if the Local and Remote Units are connected through multiple patch panels. However, the more patch panels the cable is routed through, the greater the probability that the video signal will be degraded.

NOTE

The Micro Extender has been tested and found to work, *in certain situations*, with 4-pair Category 3 cable or with four pairs of 25-pair UTP trunk cables instead of 4-pair Category 5 cable. We do not recommend such installations; if you want to experiment with them, do so at your own risk.

5. Configuration

There's a two-position DIP switch on the bottom of the Remote Unit of the ServSwitch™ Brand CAT5 KVM and KVM/Serial/Audio Micro Extenders. Position 1 governs the Remote Unit's video equalization, while position 2 controls how the Remote Unit handles keyboard-command recognition.

5.1 Setting DIP-Switch Position 1: Video Distance

The Remote Unit contains video-equalization circuitry which compensates for the loss in image quality that occurs when you drive video across cables longer than 25 m (80 ft.). If you'll be running cable between the Micro Extender's Units to such distances, you need to configure the Extender for extra equalization before you install it.

Leave position 1 of the DIP switch in the factory-default UP (OFF) setting if you'll be running cable up to (but not more than) 25 m (80 ft.) between the Units. To boost the equalization if you'll be running cable between 25 and 50 m (80 and 160 ft.), move position 1 to the DOWN (ON) setting.

If you are not running the cable too far but your video looks bad no matter how you set this DIP-switch position, the problem is almost certainly being caused by one of two things. First, check your interconnect-cable routing—does the cable pass close to a motor, generator, fluorescent lights, etc.? Second, check the wiring of the interconnect cable. Compare its pinning and pairing with those shown in **Appendix A**. (Please realize that signal equalization cannot be exact; regardless of the setting of this DIP-switch position, the remote video image might never appear quite as sharp as it would appear with the monitor directly attached to the CPU.)

5.2 Setting DIP-Switch Position 2: Keyboard-Command Recognition

The function of DIP-switch position 2 depends on the Micro Extender model:

- *On the ACU3001A and ACU3009A Remote Units*, position 2 controls how the Remote Unit handles [Scroll Lock]. Normally, pressing [Scroll Lock] on the Remote Unit's attached keyboard causes the Extender to reset itself (see **Section 7.3.1**) or, in Dual-Access systems, to go into Private Mode (see **Section 7.3.4**). But the Extender treats this keypress as a command and absorbs it, so there's no way to send [Scroll Lock] to the PC or KVM switch attached to the corresponding CPU port on the Extender's Local Unit.

Leave position 2 of the Remote Unit's DIP switch in the factory-default UP (OFF) setting if [Scroll Lock] isn't necessary for your application and can continue to be used to trigger reset/Private Mode on that Local Unit CPU port. If you need to be able to use the [Scroll Lock] key for something else on that port, move position 2 to the DOWN (ON) setting to disable reset and Private Mode and cause the Extender to pass [Scroll Lock] through to the attached PC or switch.

- *On the ACU3022A Remote Unit*, position 2 controls the Remote Unit's keyboard-command hotkey, the character that you can send from the attached keyboard to cue the Extender to expect to receive a command. Each time you press the hotkey, it will be absorbed by the Extender if it's followed by a valid command character.

The hotkey can be either left-[Ctrl] or right-[Ctrl]. In position 2's factory-default OFF setting, right-[Ctrl] is the hotkey. But you might want to use left-[Ctrl] instead, particularly if (a) a KVM switch you'll be attaching uses right-[Ctrl] as its command hotkey, or (b) a computer you'll be attaching to the Extender is a workstation such as a Compaq Alpha, HP, etc. (Instead of a standard right-[Ctrl] key, these workstations' keyboards have a [Compose] key, which shouldn't be absorbed by the Extender because it's required for use with some of the software written for these workstations.) To have the Remote Unit use left-[Ctrl] for its hotkey, move position 2 to ON. (If neither right- nor left-[Ctrl] are suitable for this purpose in your application, please call Black Box Technical Support.)

NOTE

The hotkeys of the ServSwitch Multi, ServSwitch Multi Z8, and ServSelect can be set to keypress sequences such as two consecutive left-[Ctrl] or right-[Ctrl] keys. This could cause conflicts that confuse the switch if you're using one of these ServSwitch models with the ACU3022A. To avoid such conflicts, you should set the hotkey of the ServSwitch to some completely different key ([Shift], for example) or to a keypress sequence that doesn't include either [Ctrl] key.

5.3 Setting the Microphone-Amplification Jumper in the KVM/Serial/Audio Remote Unit (Not Normally Necessary)

All sound cards that we have tested so far with the KVM/Serial/Audio Micro Extender (ACU3022A) are able to amplify the incoming signal from a microphone—the card should be set to amplify the signal by +20 dB. If the sound card of the computer you'll be attaching can do this, or if the microphone itself has on-board amplification, you can skip ahead to **Chapter 6**.

However, if you'll be attaching both (a) a microphone that can't amplify itself and (b) a sound card or audio device that can't amplify the microphone's signal, you'll have to set the KVM/Serial/Audio Micro Extender to do the amplification by installing a jumper on a pair of jumper posts labeled "MIC" mounted on an audio daughtercard inside the Remote Unit. (For microphone-installation directions, see **Section 6.2.1**.)

To reach this daughtercard, take all reasonable precautions against static electricity, then unscrew the four screws that hold on the lid of the Remote Unit. Remove the lid. You'll see the audio daughtercard above the main board, and the MIC posts near the center of the card with a jumper "hanging off" one post. Put this jumper over both posts to turn amplification on. Once you do this, the Extender will amplify the incoming microphone signal by +17 dB. When you're finished, replace the lid and screw the screws back in.

6. Installation

To install your ServSwitch™ Brand CAT5 KVM Micro or KVM/Serial/Audio Micro Extender system, first test-place it (if you want to) as described in **Section 6.1**, then attach devices as described in **Section 6.2**, then finish your installation as described in **Section 6.3**.

6.1 Test-Placing the Extender System (Optional)

We recommend testing your Micro Extender system with a test setup confined to a single room; that way, if any components are bad, you can find out before you run cable halfway across your campus. If you want to do this, gather your equipment in your test site; otherwise, place the Extender's Local and Remote Units, and the equipment you'll be attaching to them, in your desired locations.

6.2 Attaching Devices

For instructions on making device connections, refer to these subsections:

- **Section 6.2.1** for the special considerations involved in audio connections in a KVM/Serial/Audio system.
- **Section 6.2.2** for attaching a CPU to the Local Unit's CPU port.
- **Section 6.2.3** for attaching a KVM switch to the Local Unit's CPU port.
- **Section 6.2.4** for attaching a monitor, keyboard, and mouse to the user port on a Remote Unit or Dual-Access Local Unit.
- **Section 6.2.5** for attaching a KVM switch to the user port on a Remote Unit or Dual-Access Local Unit.

To attach a serial or audio device to the user port of a KVM/Serial/Audio Micro Remote Unit, follow the instructions in **Section 6.2.4**. Because few KVM switches handle serial communication in a way that's compatible with the KVM/Serial/Audio Micro Extender, we generally don't recommend attaching KVM switches to it. (One exception is the ServSwitch Multi; to attach it to the KVM/Serial/Audio Micro Extender, follow the instructions in **Sections 6.2.3** or **6.2.5**.)

As you attach devices to the Extender, here are some things to keep in mind:

- *Use caution if you're attaching KVM switches:* Different ServSwitch family KVM switch models use different proprietary signaling between cascaded switches. The only ServSwitch family switch models whose cascade signals the Micro Extenders can carry are those with a regular ServSwitch style DB25 composite interface (see the list in **Section 4.2.4.B**), so these are the only models for which you can install a Micro Extender between two cascaded (master and submaster) switch units.

Under no circumstances should you ever try to use a Micro Extender to connect two incompatible ServSwitch models. Having an Extender between them will not make them compatible.

- Each powered device should be powered OFF when you attach it.
- Make sure you don't attach your keyboard and mouse, or the keyboard and mouse strands of any multi-stranded cable, backwards. (Fortunately, the strands of the KVM-extension cable included with the Extender—and the similar EHN230 cable—are fairly easy to identify: The keyboard strand is orange or purple and labeled with the picture of a keyboard, while the mouse strand is green and labeled with the picture of a mouse.)
- If you run audio cables to and from a KVM/Serial/Audio model, make sure to run from “audio out” on the device to “audio in” on the Extender Unit, and vice versa.
- If your Extender is a Dual-Access model, connect your CPU or the user port of your KVM switch to the Local Unit's CPU port (the DB25 connector on the *bottom* row) only, and connect user equipment or the CPU port of your KVM switch to the Local Unit's user port (the connectors on *top* row) only.

6.2.1 SPECIAL CONCERNS ABOUT CONNECTING AUDIO DEVICES TO THE KVM/SERIAL/AUDIO MICRO EXTENDER

Before you connect any sound equipment to the KVM/Serial/Audio Micro Extender, here are some things you should keep in mind:

The Extender's audio interface is stereo, bidirectional (sound can be transmitted in both directions across the link at the same time), and line-level (it supports devices that transmit and receive at up to 5 volts peak-to-peak). In the output ("line out") direction, it's designed to take the output from a computer's sound card or other line-level source and send it to a set of powered speakers at the remote site. In the input ("line in") direction, it's designed to take input from a microphone at the remote site and send it to a local sound card or other line-level destination. It can also send signals in the opposite directions (for example, sound from a remote source to local speakers, or from a local microphone to a remote recorder), although a local microphone would have to be self-amplified and would have to output signals at line level. The Extender's audio connectors are labeled on the top of each Unit's case with a speaker icon and the words "Out" (above the audio-out port) and "In" (above the audio-in port).

- To attach headphones or powered speakers: Plug the headphones or speakers directly into the Local or Remote Unit's audio-out connector. Run a standard 3.5-mm mini stereo audio cable such as product code EJ110-0010 from the audio-in connector of the Remote or Local Unit at the other end of the link to the "LINE OUT" connector of a PC or sound card—colored lime (yellow-green) in the PC99 specifications, but often colored differently—or of a CD player or other audio source.
- To attach a microphone that the sound card will be amplifying (the preferred type of microphone attachment): Plug the microphone directly into the Remote Unit's audio-in connector. Run a standard 3.5-mm mini stereo audio cable such as product code EJ110-0010 from the Local Unit's audio-out connector to the sound card's "MIC" ("microphone in") connector (colored pink in the PC99 specifications, but often colored differently).

To attach a self-amplified microphone, CD player, etc.: Plug the device directly into the Local or Remote Unit's audio-in connector. Run an audio cable such as EJ110-0010 from the audio-out connector of the Remote or Local Unit at the other end of the link to the "LINE IN" connector of a PC's sound card—colored light blue in the PC99 specifications—or of a tape recorder or other audio destination.

To attach a microphone that the Extender will have to amplify itself: Set the Extender's MIC jumper as described in **Section 5.3**. Plug the microphone directly into the Remote Unit's audio-in connector. Run an audio cable such as EJ110-0010 from the Local Unit's audio-out connector to the sound card's "LINE IN" connector (colored light blue in the PC99 specifications).

6.2.2 ATTACHING A CPU TO THE LOCAL UNIT'S CPU PORT

Attach the keyboard, video, and mouse connectors of the included three-to-one KVM-extension cable to the matching ports on the CPU, as shown in Figure 6-1. Attach the DB25 male connector of this cable to the Local Unit's DB25 female composite CPU-port KVM connector.

To make the additional serial connection from a PC to a KVM/Serial/Audio Local Unit, attach the female end of the included DB9 male-to-female serial-extension cable to the CPU's serial (COM) port, then attach the male end of the cable to the Local Unit's matching DB9 female CPU-port serial connector.

To make the additional audio connections from a CPU to a KVM/Serial/Audio Local Unit, first run one of the included 3.5-mm male-to-male stereo audio-extension cables from the CPU's audio-out port to the Local Unit's "In" port. Then run the other included audio cable from the CPU's microphone port to the Hub's "Out" port. See **Section 6.2.1** for additional guidelines.

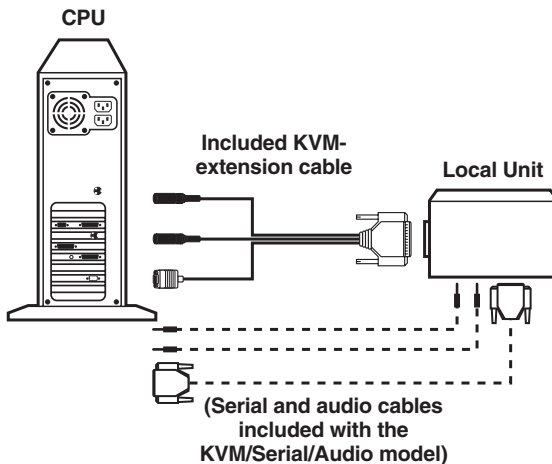

Figure 6-1. Attaching a CPU to the Local Unit's CPU port.

6.2.3 ATTACHING A SERVSWITCH FAMILY KVM SWITCH TO THE LOCAL UNIT'S CPU PORT

The way you'll do this will depend on whether the KVM switch's user ports are multiple connectors (see **Section 6.2.3.A**) or single composite connectors (see **Section 6.2.3.B**). (Refer to the listings in **Section 4.2.2** for which ServSwitch family models are in which category.)

6.2.3.A Attaching a KVM Switch with Multiple User-Port Connectors

Attach the keyboard, video, and mouse connectors of the Extender's included three-to-one KVM-extension cable to the matching user-port connectors on the KVM switch, as shown in Figure 6-2. Attach the DB25 male connector of this cable to the Local Unit's DB25 female composite CPU-port KVM connector.

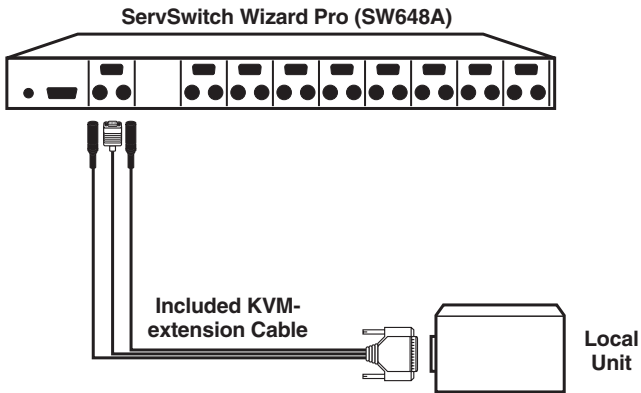

Figure 6-2. Attaching a KVM switch with multiple user-port connectors to the Local Unit's CPU port.

6.2.3.B Attaching a KVM Switch with Single Composite User-Port Connectors

If the KVM switch's user ports are ServSwitch style DB25 connectors, run a ServSwitch to ServSwitch Expansion Cable (product code EHN284) from one of these connectors to the Local Unit's DB25 female CPU-port KVM connector, as shown in Figure 6-3.

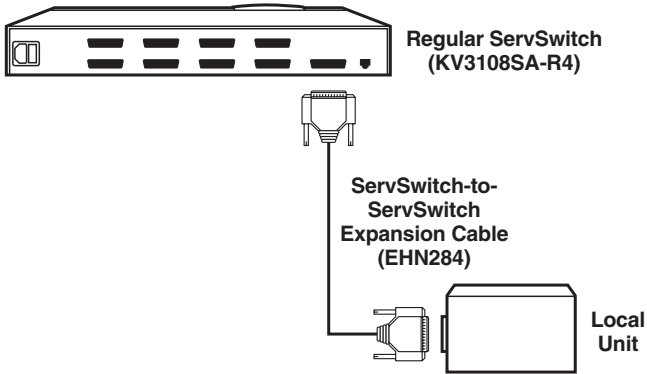

Figure 6-3. Attaching a KVM switch with a single compatible user-port connector to the Local Unit's CPU port.

If the KVM switch's user ports are some other type of composite connectors (as is the case for the ServSwitch Multi), first plug a User Cable designed for the KVM switch (see Section 4.2.2.C for ServSwitch Multi cable product codes) into one of the switch's user ports. Then plug the Extender's included three-to-one KVM-extension cable into the Local Unit's DB25 female CPU-port KVM connector.

If your Local Unit is a KVM/Serial/Audio model and you want to do serial extension, also plug the male end of the included DB9 male-to-female serial-extension cable into the Local Unit's matching DB9 female CPU-port serial connector.

If your Local Unit is a KVM/Serial/Audio model and you want to do audio extension, also plug one end of the included 3.5-mm male-to-male stereo audio-extension cables into the Local Unit's matching 3.5-mm female CPU-port audio "In" and "Out" connectors.

Finally, connect the other ends of the Extender's KVM-extension cable (and any serial-extension or audio-extension cables) to the matching strands of the switch's User Cable as shown in Figure 6-4 on the next page.

NOTES

If the switch is a ServSwitch Multi, keep these things in mind as you match the serial and audio cables/strands:

- The proper DB9 serial connector to use on its User Cable is the one *without* a yellow band.
- The audio cable from the Local Unit's "Out" connector should be plugged into the *blue-banded* audio connector on the User Cable.
- The audio cable from the Local Unit's "In" connector should be plugged into the audio connector *without* a blue band on the User Cable.

Also bear in mind that the microphone strand of the ServSwitch Multi User Cable (the one with the *blue-banded* connector) is mono only, so any stereo information that passes through this strand will be lost.

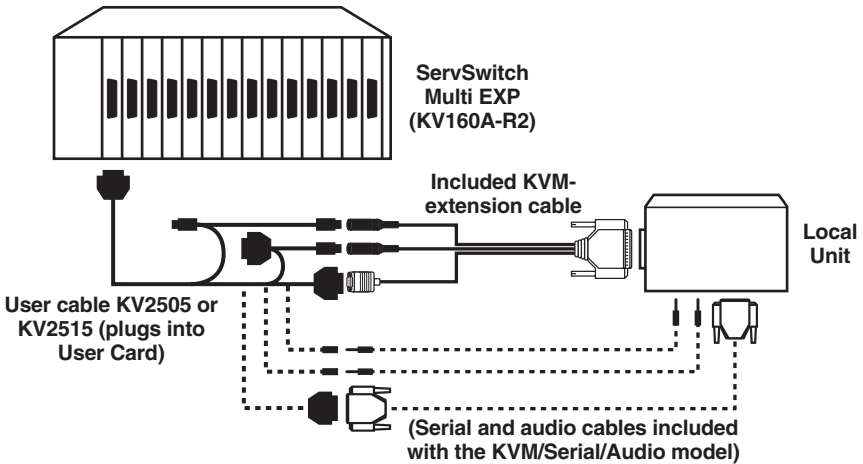

Figure 6-4. Attaching a KVM switch with a single incompatible user-port connector to the Local Unit's CPU port.

6.2.4 ATTACHING USER-STATION EQUIPMENT TO THE USER PORT ON A REMOTE UNIT OR DUAL-ACCESS LOCAL UNIT

Plug the user station's monitor, keyboard, mouse, any touchscreen or other serial device, and any audio devices directly into the matching user-port connectors on the Remote Unit or Dual-Access Local Unit.

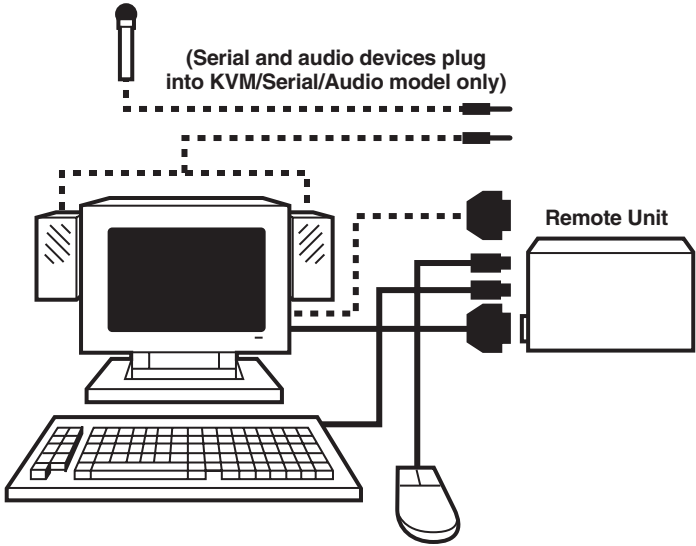

Figure 6-5. Attaching user equipment to the user port on an Extender Unit.

6.2.5 ATTACHING A SERVSWITCH FAMILY KVM SWITCH TO THE USER PORT ON A REMOTE UNIT OR DUAL-ACCESS LOCAL UNIT

The way you'll do this will depend on whether the KVM switch's CPU ports are multiple connectors (see **Section 6.2.5.A**) or single composite connectors (see **Section 6.2.5.B**). (Refer to the listings in **Section 4.2.4** for which switch models are in which category.)

6.2.5.A Attaching a Switch with Multiple CPU-Port Connectors

Run extension cabling from the user-port connectors on the Remote Unit or Dual-Access Local Unit to the matching CPU-port connectors on the KVM switch. This extension cabling can be individual keyboard-, video-, and mouse-extension cables (product codes EVMPS03-MM for keyboard and mouse, EVNPS05-MM for video), but we recommend our specially bonded three-to-three CPU-extension cable (product code EHN408):

- If you're using individual extension cables, run the video-extension cable between the two video/monitor connectors, the keyboard-extension cable between the two keyboard connectors, and the mouse-extension cable between the two mouse connectors.
- If you're using one of our three-to-three bonded extension cables, run the cable's video strand between the two video/monitor connectors, the cable's keyboard strand between the two keyboard connectors, and the cable's mouse strand between the two mouse connectors, as shown in Figure 6-6. (The keyboard and mouse connectors on the bonded cable have different colors and icon labels for easy identification.)

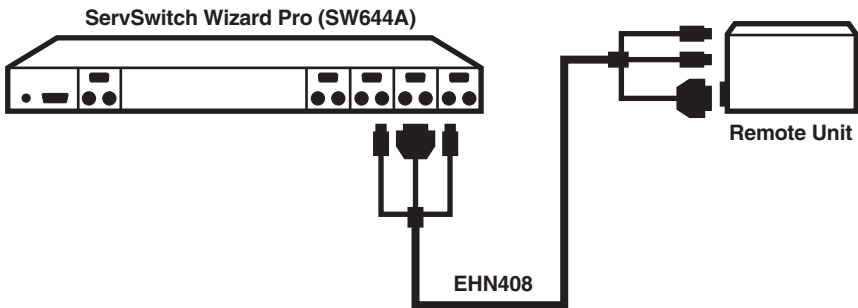

Figure 6-6. Attaching a KVM switch with multiple CPU-port connectors to the user port on an Extender Unit.

6.2.5.B Attaching a Switch with Single Composite CPU-Port Connectors

Run a CPU Cable designed for the KVM switch—refer to **Sections 4.2.4.B** and **4.2.4.C** for product codes—from one of the switch’s CPU-port connectors to the user-port connectors of the Remote Unit or Dual-Access Local Unit, as shown in Figure 6-7 on the next page. (For the regular ServSwitch and the other switches listed in **Section 4.2.4.B**, the Extender’s included KVM-extension cable will work for this purpose if you haven’t already used it to attach a CPU or switch to the Local Unit’s CPU port.)

NOTES

If the switch is a ServSwitch Multi, keep these things in mind as you match the serial and audio cables/strands:

- The proper DB9 serial connector to use on its User Cable is the one *without* a yellow band.
- The audio cable from the Extender Unit’s “Out” connector should be plugged into the *blue-banded* audio connector on the User Cable.
- The audio cable from the Extender Unit’s “In” connector should be plugged into the audio connector *without* a blue band on the User Cable.

Also bear in mind that the microphone strand of the ServSwitch Multi User Cable (the one with the *blue-banded* connector) is mono only, so any stereo information that passes through this strand will be lost.

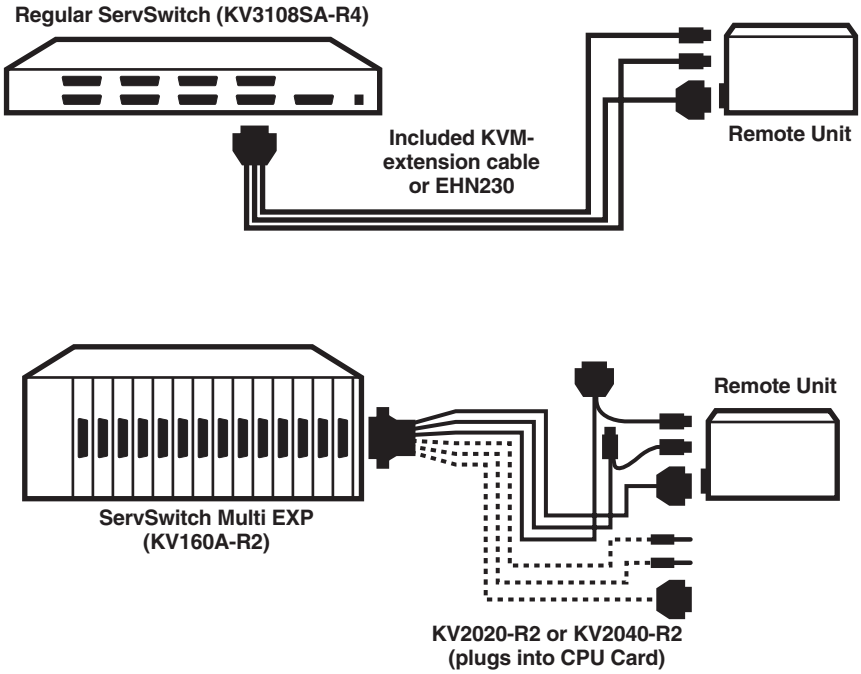

Figure 6-7. Attaching a KVM switch with single composite CPU-port connectors (regular ServSwitch shown at top, ServSwitch Multi shown at bottom) to the user port on an Extender Unit.

6.3 Finishing Your Installation

To finish installing your Micro Extender system after attaching devices to it as described in **Section 6.2**, take these steps:

1. Attach the output cord of the Remote Unit's power supply to the Unit's power jack. Then plug the IEC 320 end of the power supply's input cord into the IEC 320 inlet on the power supply's transformer. Finally, plug the other end of the input cord into a utility (mains) power outlet. The Remote Unit should power up immediately; it has no ON/OFF switch. (If the Remote Unit is in the location you want it to be, you can leave it plugged in and powered up more or less indefinitely.)

CAUTION!

If you ever need to replace the Remote Unit's power supply, the replacement power supply must have identical output characteristics (see the "Power" specification in Chapter 2). Using a power supply with different output—even if it's "almost the same"—could damage your equipment.

2. Power ON the monitor or KVM switch attached to the Remote Unit. *Dual-Access systems:* Power ON any monitor or switch attached to the Local Unit's user ports.
3. Interconnect the Local and Remote Units by running CAT5 cable between their right-side-mounted modular jacks (the ones labeled "Interconnect"). Refer to the guidelines for this cable in **Section 4.2.5**.
4. Power ON the PC CPU or KVM switch attached to the Local Unit's CPU port. If the CPU or switch provides enough DC voltage on its keyboard port/leads, the Local Unit will begin operating immediately; like the Remote Unit, it has no ON/OFF switch. The LED on the Local Unit's right-side panel should light steadily (to show that it's powered). Once the Local Unit has detected both (a) the presence of the Remote Unit and (b) initial keyboard commands from the PC, this LED should start flashing regularly (to show that the link between the Units is working).

If this LED doesn't light, check the CPU or switch (is it actually on?) and the KVM-extension cables (are they securely connected to the proper ports at both ends?). If this LED lights but remains steadily lit, even after more than a minute (it might take some older CPUs that long to boot to the point at which they attempt to communicate with the keyboard), check the CAT5 cable between the Units (is it secure at both ends? is it intact, or is it broken?).

5. If the Local Unit's LED shows that the link between the Units appears to be working, make sure that the remote keyboard functions and that you're getting video at the remote site. (Be aware that in Dual-Access systems, remote monitors, keyboards, and mice might take up to several seconds to be properly initialized; see **Section 7.3.3**. Note also that the video quality might be poor at this point if your interconnect cable is longer than 25 m [80 ft.] and you haven't set the Extender's DIP switch to compensate for this; see **Section 5.1**.)
6. Make sure the remote mouse functions. (If your PC normally boots up in DOS, you will need to run Windows or some application that supports the mouse.)
7. *KVM/Serial/Audio systems only*: Make sure that any serial device attached to your Remote Unit is working. You might need to load a driver or run an application in order for the CPU to be able to detect and handle the serial data.
8. *KVM/Serial/Audio systems only*: Make sure that any audio devices attached to your Remote Unit is working.

If everything works in your test setup, repeat the above steps for your actual installation. If everything works in the actual installation, your ServSwitch™ Brand CAT5 KVM Micro Extender system should be ready for continuous operation.

7. Operation

7.1 Keyboard and Mouse Emulation

The ServSwitch™ Brand CAT5 KVM and KVM/Serial/Audio Micro Extenders use a microprocessor to emulate the presence of a directly connected keyboard and mouse for the attached PC. This means that you don't have to connect a keyboard or mouse to the PC in order for it to boot; in fact, the PC will boot with only the Local Unit connected.

This feature makes several other things possible:

- Your PC can operate continuously regardless of whether or not the Micro Extender's Remote Unit (or any local user equipment in a Dual-Access system) is powered, connected, or even present.
- You can “hot-plug” or “hot-swap” keyboards and mice attached to the Extender at any time; that is, you can unplug and replug the keyboard and mouse without disrupting the operation of the PC.
- You can connect different CPUs to different Remote Units at different times in order to create a “switched” KVM-extension system. You can do this by moving cable between patch-panel ports or directly between Extender Units, although you should do this as infrequently as possible to avoid wearing out the connectors on your cable and devices. Or you can use a CAT5 switch, but the switch must carry all eight wires (maintaining the twists between the wire pairs) and must have enough bandwidth to support your system's video demands. Please call Black Box Technical Support to discuss your application before installing such a system.

7.2 Normal Operation and Keyboard Typematic Rate

With the exception of the shared-access features of the Dual-Access model (see **Sections 7.3.3** and **7.3.4**), the Micro Extender should operate continuously and transparently, maintaining the long-distance connection between the local CPU or KVM switch and the remote user station or KVM switch. Note that the remote keyboard's typematic rate—the rate at which a held-down character will repeat—is fixed at 30 characters per second, which is also the default typematic value for Windows.

7.3 Keyboard Commands and Related Functions

This section describes Micro Extender functions that can be controlled with commands that users can type in at the user-station keyboards, as well as some related functions. The different Extender models have different command formats:

- The ACU3001A and ACU3009A use [Scroll Lock] as a single multipurpose “command key”—pressing and releasing it different numbers of times, sometimes while pressing the mouse buttons, causes the Extender to do various things.

Very few of today’s software applications make use of the [Scroll Lock] key, but if you’re using such an application on the PC attached to the Extender, you can force the Extender to ignore the [Scroll Lock] character and pass it through to the PC. Do this by setting position 2 of the Remote Unit’s DIP switch to ON (see **Section 5.2**). Turning off [Scroll Lock] recognition will disable the Extender’s reset command (see **Section 7.3.1**), and on the Dual-Access model it will disable Private Mode as well (see **Section 7.3.4**).

- The ACU3022A uses either left-[Ctrl] or right-[Ctrl] as a “hotkey” that will trigger the Extender to expect an additional command character. Right-[Ctrl] is the default hotkey, but you can change it to left-[Ctrl] if necessary by moving position 2 of the Remote Unit’s DIP-switch SW1 to ON (see **Section 5.2**).

For a quick summary of all of the Micro Extender’s keyboard commands, see **Appendix B**.

7.3.1 RESETTING THE KEYBOARD AND MOUSE

When a Micro Extender system is set to its factory defaults, or if a keyboard or mouse attached to the Extender ever lock up, you can reinitialize a user station’s keyboard and mouse by typing in a reset command at the keyboard of a user station attached to the Extender:

- In an ACU3001A Single-Access system, press and release the [Scroll Lock] key *once*.
- In an ACU3009A Dual-Access system, press and release the [Scroll Lock] key *once* at the Remote Unit or *twice* at the Local Unit.
- In an ACU3022A KVM/Serial/Audio system, press and release the hotkey, then press and release the up-arrow (number 8) key on the keyboard’s numeric keypad (*not* the number 8 on the top row of the keyboard).

Note that the Extender will automatically reinitialize the keyboard and mouse whenever you attach them. If a reset doesn't help your remote keyboard or mouse, try cycling power to the Remote Unit.

7.3.2 CORRECTING THE PS/2 MOUSE IF IT GETS OUT OF SYNC

On rare occasions, you might notice that, instead of behaving normally, your mouse pointer is moving and jumping erratically all over the screen (and possibly selecting things at random). This is usually a sign that the PS/2 mouse has gotten “out of sync” with the Micro Extender or that the Micro Extender has gotten out of sync with the CPU's PS/2 mouse port.

Explanation: PS/2 mice send mouse data in 3- or 4-byte packets. As long as the CPU knows which bytes mark the start and end of each packet—which it virtually always does as long as the mouse is directly connected to it—it can correctly interpret the mouse signals. But when mice are disconnected and reconnected, or when mouse signals pass through other devices on their way to the CPU, it is sometimes possible for the CPU or the intervening devices to lose track of where the mouse-data packets begin and end, with the result that the cursor/pointer begins behaving bizarrely.

If this happens in some mouse extender/switch systems, the only solution is to either kill and reload the mouse driver or reboot the PC. But the Micro Extender has a feature you can use to painlessly recover from this kind of glitch. First try to reset the mouse by pressing and releasing Scroll Lock on the keyboard as described in **Section 7.3.1**. If this doesn't work, send the “Null Mouse Command” in order to resynchronize the CPU's mouse port. To do this with the ACU3022A, press and release the hotkey, then press and release the left-arrow (number 4) key on the keyboard's numeric keypad (*not* the number 4 on the top row of the keyboard). With either of the other models, take these steps:

1. Press and hold down both the left and right mouse buttons.
2. Press and release the [Scroll Lock] key on the associated keyboard, then release the mouse buttons.
3. Check mouse operation.
4. If the mouse isn't yet operating correctly, repeat steps 1 through 3 as many as two more times. (If this still doesn't help, call Black Box Technical Support.)

When the Micro Extender receives the Null Mouse Command, it sends a “null byte” of mouse data to the CPU; this has no effect other than to get the CPU “caught up” with the mouse. You might have to issue the command as many as

three times in order to get a PC with a 4-byte mouse back on track. Note that, unless your mouse driver is an auto-correcting type, sending this command while the mouse is in sync will throw it out of sync.

If the PS/2 mouse frequently gets out of sync in your system, and you are running Windows 95/98/2000, Windows Me®, Windows NT®, or Windows XP®, we recommend that you install the latest Microsoft mouse driver on your PC, or even the Microsoft IntelliMouse driver on your PC, regardless of whether you are actually using an IntelliMouse or not. The Micro Extender will translate the mouse signals for this driver, and the driver will auto-correct the synching problem if you let go of the mouse for a second or two.

7.3.3 THE INACTIVITY TIMEOUT (ACU3009A DUAL-ACCESS SYSTEMS ONLY)

Because two user stations (one local, one remote) can be attached for the same CPU, Dual-Access Micro Extender systems have “shared access” features, including Private Mode (see **Section 7.3.4**) and an “inactivity timeout.” While the inactivity timeout isn’t controlled by a keyboard command per se, it responds to general keyboard activity.

The two stations attached to the Micro Extender normally contend for access. When there has been no keyboard or mouse activity on one station for two seconds, the Extender will switch to the first station from which it detects keyboard keypress or mouse movement.

This “inactivity timeout” prevents a user at the other station from interrupting work in progress at the active station. Because this timeout is in effect, when the Extender system boots up, the Extender gives control (and its total attention) to the local station for at least the first two seconds; this means that the remote monitor might be blank, and the remote keyboard and mouse inactive, for that long.

Here’s how it works: A user station is activated by pressing a key on its keyboard or by moving the mouse. This first keypress, or the first packet of mouse data, is absorbed by the Extender and is not passed on to the PC. The Extender “latches onto” this user station; users at the other station can see what’s happening on their monitor, but can’t control the PC with their keyboard or mouse while the active station is in use. Once the active station’s keyboard and mouse are idle for more than two seconds, the Extender “lets go” of that station, and will switch to whichever station it next detects keyboard input from.

7.3.4 PRIVATE MODE (ACU3009A DUAL-ACCESS SYSTEMS ONLY)

For applications in which a Dual-Access Micro Extender system's remote user station is not in a secure location, or must be temporarily kept from accessing the local PC, users at the local station can trigger the Extender's "Private Mode," which prevents the remote station from taking control of the local PC even if the inactivity timeout (see **Section 7.3.3**) expires. (The local user station can go into Private Mode and lock out the remote station, but not vice versa.)

When users at the local station have control of the Micro Extender, they can force it into Private Mode (taking exclusive control of the PC) by pressing [Scroll Lock] *once* on the local keyboard. The Scroll Lock LED will light on *both* the local *and* remote keyboards. Other than this indication, the remote station is almost completely disabled: The monitor goes blank and the keyboard and mouse stop working.

Local users must press [Scroll Lock] again to re-enable the remote user station; when they do so, the Extender also reinitializes the local keyboard and mouse. (To reset the local keyboard and mouse without going into Private Mode, quickly press and release [Scroll Lock] *twice*, as directed in **Section 7.3.1**.)

The Extender will not go into Private Mode unless there's a powered PC attached to the CPU port on the Local Unit.

Very few applications today make extensive or important use of the [Scroll Lock] key. But if you are using such an application on a PC attached to the Extender, you can force the Extender to pass [Scroll Lock] through to the PC, disabling both Private Mode and the reset function (see **Section 7.3.1**) by setting DIP-switch position 2 on the Remote Unit to OFF (see **Section 5.2**).

8. Troubleshooting

8.1 Common Problems

This section discusses difficulties that people sometimes have with the ServSwitch™ Brand CAT5 KVM and KVM/Serial/Audio Micro Extenders, and suggests possible remedies. If the recommended actions don't help, or if you don't see your problem here, or if your problem keeps recurring, call Black Box Technical Support as directed in **Section 8.3**.

8.1.1 KEYBOARD

The PC boots correctly with no error messages but the keyboard does not work at all.

1. Check the keyboard cable and (if necessary) the keyboard portion of the extension cabling to your CPU or KVM switch; if it's loose, or if you have the keyboard and mouse cables reversed (plugged into each other's Micro Extender ports), plug the cable(s) in properly and reset the keyboard and mouse as described in **Section 7.3.1**.
2. Check the interconnect cable between the Micro Extender's Local and Remote Units. Is it intact along its length and securely connected at both ends? And is it wired correctly? (Compare its wiring with that shown in **Appendix A**.)
3. If the PC is a Pentium® class machine, see the entry for the "Pentium class PC..." problem in **Section 8.1.3**.
4. Try a different model of keyboard. If the new keyboard works, the original one might be incompatible (some older autosensing keyboards don't work with the Micro Extender).

When I press keys on my keyboard the wrong characters appear.

1. Your keyboard might be in the wrong mode. Reset the keyboard and mouse as described in **Section 7.3.1**.
2. Power down and reboot the entire system.

The PC always comes up with "Keyboard Error."

1. If the system appears to work fine after you press [F1] or [ESC], adjust your BIOS setup so that the PC doesn't test the keyboard.
2. If the PC is a Pentium class machine, see the entry for the "Pentium class PC..." problem in **Section 8.1.3**.

Connecting a keyboard to the Remote Unit has an adverse effect on the remote video.

Try using a newer keyboard. (Some older keyboards require too high a current for the Remote Unit to properly drive the video signal.)

I'm not using a keyboard, but the Extender doesn't work at all.

See **Section 8.1.7**.

8.1.2 MOUSE

There is a mouse cursor/pointer on the screen, but the mouse does not work.

1. Reset the keyboard and mouse as described in **Section 7.3.1**.
2. Check the mouse cable and (if necessary) the mouse portion of the extension cabling to your CPU or KVM switch; if it's loose, or if you have the keyboard and mouse cables reversed (plugged into each other's Micro Extender ports), plug the cable(s) in properly and reset the keyboard and mouse as described in **Section 7.3.1**.
3. If the PC is a Pentium class machine, see the entry for the "Pentium class PC..." problem in **Section 8.1.3**.
4. Check the interconnect cable between the Micro Extender's Local and Remote Units. Is it solid-core cable? Is it intact along its length and securely connected at both ends? And is it wired correctly? (Compare its wiring with that shown in the **Appendix A**.)
5. Try powering the Remote Unit OFF and then ON again.
6. Try using a different model of mouse.
7. Do *any* inputs work at this point? If not, reboot the PC.

The PC does not detect a PS/2 mouse, or the application cannot find the mouse.

1. Check the mouse cable and (if necessary) the mouse portion of the extension cabling to your CPU or KVM switch; if it's loose, or if you have the keyboard and mouse cables reversed (plugged into each other's Micro Extender ports), plug the cable(s) in properly and reset the keyboard and mouse as described in **Section 7.3.1**.
2. Make sure that the cable running from the keyboard port of the CPU or KVM switch to the Micro Extender's Local Unit is intact and securely attached, so that it provides power to the Local Unit.
3. If the PC is a Pentium class machine, see the entry for the "Pentium class PC..." problem in **Section 8.1.3**.
4. Reboot the PC.

The mouse is behaving erratically.

1. Reset the keyboard and mouse as described in **Section 7.3.1**.
2. Issue the Null Mouse Command up to three times (see **Section 7.3.2**).
3. If your PC is running Windows 95/98/2000, Windows Me, Windows NT, or Windows XP, regardless of what type of mouse you have, install the latest Microsoft driver for a standard mouse or (even if you have a standard mouse) the IntelliMouse. The Micro Extender will translate the mouse signals for this driver, and the driver will auto-correct the synching problem if you let go of the mouse for a second or two.
4. If you're using the Micro Extender in conjunction with one of our ServSwitch family of KVM switches, command the Switch to reset the mouse.
5. Quit and restart the application.
6. Reboot the PC.

8.1.3 BOTH KEYBOARD AND MOUSE

Neither the keyboard nor the mouse operates, or both have locked up.

1. If they have both locked up, first try resetting the keyboard and mouse as described in **Section 7.3.1**.
2. Reset the PC and try again.
3. If the problem is happening at the remote station, cycle power to the Remote Unit.

My Pentium class PC will not boot properly due to keyboard or mouse problems, or After my Pentium class PC boots, the keyboard and/or mouse won't work.

Try “crossing” the keyboard- and mouse-extension cables running from the Extender's Local Unit to your PC. That is, plug the keyboard cable or cable strand into the CPU's mouse port and the mouse cable or cable strand into the CPU's keyboard port.

If this works, here's why: The BIOS installed in some machines with Intel Pentium family processors checks the PC's keyboard and mouse ports at boot time. If it detects anything that leads it to suspect that the user has plugged the keyboard and mouse in backwards—that is, into each other's CPU ports—it “remaps” the ports, so that the keyboard port functions as the mouse port and vice versa. BIOS of this type sometimes mistakenly activates port remapping when the PC is attached to an Extender.

8.1.4 SERIAL DEVICE (ACU3022A KVM/SERIAL/AUDIO SYSTEMS ONLY)

The CPU doesn't detect the serial device I'm trying to use with it.

1. Make sure that the data rates of the device and the CPU's serial port both match, and that the data rate doesn't exceed 19,200 bps.
2. Make sure that the device and your PC's driver or serial-communication program are using the same type of flow control.

The CPU doesn't seem to receive anything from its serial device or vice versa.

1. If possible, attach the serial device directly to the CPU. If it works, skip to #2. If it doesn't, is the device actually standard RS-232? Is it a device the CPU supports? Is a driver for the device loaded, or is software running, that enables the CPU to recognize input from the device?
2. Check the serial cables. Are they intact along their length and securely connected at both ends?
3. Check the data rate. Is the device operating at a rate not exceeding 19,200 bps? Is the CPU's serial port set to the same data rate?
4. Check the data format and flow control. Are the device and your PC's driver or serial-communication program using the same format and flow-control type?
5. Is your PC a UNIX® workstation? In order to operate correctly, some UNIX workstations need to see the DCD signal from the serial device, but the Extender doesn't carry DCD. Call Black Box Technical Support if you've ruled out the other possibilities and suspect that this might be your problem.

The CPU receives garbage from its serial device or vice versa.

1. Make sure that the data rates of the device and the CPU's serial port both match, and that the data rate doesn't exceed 19,200 bps.
2. Make sure that the device and your PC's driver or serial-communication program are using the same data format.

8.1.5 AUDIO DEVICES (ACU3022A KVM/SERIAL/AUDIO SYSTEMS ONLY)

Sound doesn't seem to get through from the local site to the remote site or vice versa.

1. Check the audio cables, including those attached to your speakers. Are they intact along their length and securely connected at both ends? Are all cables running correctly from “audio out” to “audio in”?
2. Is your sound card actually outputting anything? Check this by temporarily attaching some speakers directly to the card.

Sound is distorted.

1. At what level is sound being output to the Extender? If it's above line level (5 volts peak-to-peak), sound will be distorted as it passes through the Extender. The Extender doesn't support devices that output above line level.
2. What type of speakers have you attached to the Extender? The Extender doesn't support the older, cheap, non-amplified speakers that could be plugged into the “SPEAKERS” jack on old sound cards.

8.1.6 VIDEO

The picture is not sharp, or is badly smeared.

1. DIP-switch position 1 on the Remote Unit might not be set for the correct distance. See **Section 5.1**.
2. Check the interconnect cable between the Micro Extender's Local and Remote Units. Is it solid-core cable, rated as Category 5 (Category 5e might provide acceptable performance)? Is it intact along its length and securely connected at both ends? And is it wired correctly? (Compare the cable's specs with those listed in **Section 4.2.5** and its wiring with that shown in **Appendix A**.)
3. Check the video-extension cabling, patch-panel video connections, and other video connections in the system. Make sure everything is properly and securely attached.
4. Are you using an LCD panel? You might need to reduce the refresh rate of your graphics card's output.

Each character has separated into overlapping sets of red, green, and blue pixels; the effect is like trying to watch a 3-D movie without 3-D glasses.

1. Check the interconnect cable between the Micro Extender's Local and Remote Units. Is it solid-core cable, rated as Category 5 (Category 5e might provide acceptable performance)? Is it intact along its length and securely connected at both ends? And is it wired correctly? (Compare the cable's specs with those listed in **Section 4.2.5** and its wiring with that shown in **Appendix A**.)
2. Check the video-extension cables, patch-panel video connections, and other video connections in the system. Make sure everything is properly and securely attached.
3. DIP-switch position 1 on the Remote Unit might not be set for the correct distance. See **Section 5.1**.

The monitor sometimes loses sync, causing it to go blank for a second or two.

This could happen if your electrical power system is very noisy (particularly on the ground lead). Also, don't route your interconnect cable anywhere near power lines or other powerful sources of interference such as generators, motors, or fluorescent lights. If this is a persistent problem, please discuss it with Black Box Technical Support.

I only need video, serial, or audio extension—not keyboard or mouse control—but I can't get a picture.

Even if you are only using the Micro Extender for video extension (to drive video to a remote monitor), serial extension (to drive RS-232 to or from a remote touchscreen or other device), or audio extension (to drive audio to or from remote devices), the Extender's Local Unit must still be attached to the PC's keyboard port, because that's where it gets its power. If your application makes it impossible to connect the Extender to a keyboard port, call Black Box Technical Support about getting an alternative power supply for the Local Unit.

I get a constant vertical wobble down the screen. What is the cause of this interference?

1. The interconnection cable could be located too close to a source of very strong electrical-power interference; reroute the cable if possible.
2. If the wobble forms a standing "beat pattern," the Micro Extender is probably being affected by a very strong signal from a nearby broadcast transmitter. Try changing the vertical refresh rate slightly (for example, from 60 Hz to 70 Hz or vice versa).
3. You might require an alternative power supply for the Remote Unit. Call Black Box Technical Support.

I get black & white instead of color video.

Your CPU probably needs to see monitor ID in order to boot into the correct video mode. Please contact Black Box Technical Support.

Microsoft Windows 3.x, 95, 98, or 2000, Windows Me, Windows NT, or Windows XP will only boot into a low-resolution graphics mode.

1. If your graphics card supports VESA DDC (Display Data Channel), configure the graphics driver by explicitly telling it which make and model of monitor you're using, rather than letting the driver configure itself automatically (and probably erroneously) through DDC, which the Extender doesn't support.
2. The CPU might need to see monitor ID in order to boot into the correct video mode. Please contact Black Box Technical Support.

Connecting a keyboard to the Remote Unit has an adverse effect on the remote video.

Try using a newer keyboard. (Some older keyboards require too high a current for the Remote Unit to properly drive the video signal.)

The Extender doesn't seem to work correctly with my LCD panel.

Try reducing the refresh rate of the video signal that your graphics card is outputting. (The maximum refresh rates supported by most LCD panels are less than those supported by most monitors.)

8.1.7 POWER

I don't need to use keyboards in my application, but the Extender doesn't work at all unless I have a keyboard line running from the Local Unit to the PC or KVM switch.

The Micro Extender's Local Unit normally operates using the 5 volts of DC power that the attached CPU or KVM switch supplies on its keyboard and mouse ports. Even if you're not using a keyboard or mouse, run a cable from the Local Unit's CPU port to the keyboard port of the CPU or switch in order to power the Local Unit. If this is not possible, call Black Box Technical Support about getting an alternative power supply for the Local Unit.

8.2 General Questions About the Micro Extender

Is it possible to use an interconnection cable longer than 50 meters (160 feet)?

The standard-from-the-factory Micro Extender has been designed to produce acceptable results with SVGA resolutions at the maximum cable length of 50 m (160 ft.). You can try running cable farther, but not very far beyond 50 m the video quality begins to degrade rapidly. If you need to run longer distances, please contact Black Box Technical Support; they might be able to suggest more powerful alternative equipment.

Can Micro Extender Units be daisychained to allow operation across a distance greater than 50 meters (160 feet)?

We do not recommend doing this, because the Micro Extenders' video equalization can't be fine-tuned and can easily break down over the length of a daisychain.

Can the Micro Extender be used between buildings?

No. Ground loops could destroy the Micro Extender and attached equipment.

Can I rackmount the Micro Extender?

The Micro Extender is designed for desktop use. You could set it on a rack shelf, but there are not currently any rackmount or wallmount kits available for it.

Is the Micro Extender VESA DDC compatible?

No. It cannot carry the special DDC data lines.

Can the Micro Extender be used with RGB video?

As long as the video has sync on green (the composite sync signal superimposed on the green color signal), there should be no problem.

Which cable type is better: UTP (unshielded twisted-pair) or STP (shielded twisted pair)?

In electrically quiet environments, UTP cable will give the best quality video over long distances because it has less capacitance per unit length. However, STP is usually better in electrically noisy environments, because it resists interference more strongly.

When using UTP, what's the best way to make sure that the system does not suffer from any interference?

The Micro Extender is designed to withstand high levels of interference while driving signals over UTP. To further reduce the potential for interference, consider taking these actions:

- a) Make sure that the Micro Extender's Remote Unit; remote monitor, serial device, audio devices, and/or KVM switch; and local CPU or KVM switch are all connected to the same utility-power (mains) phase.
- b) Make sure that the AC voltage across the utility-power (mains) grounds (at both the local PC or switch and remote monitor or switch) is less than 2V.
- c) Use a "clean earth" or "clean grounding" system (if your site has one installed).
- d) Route the interconnection cable away from generators, motors, compressors, fluorescent lights, and other cables.
- e) Try STP cable if you think noise could be a problem.

This interconnect cable is exactly like the cable I use on my LAN. Can I connect the Micro Extender to my network?

Absolutely not. Regardless of the cable similarities, the data signals and voltages used by the Micro Extender are totally different from those used by Ethernet and other types of networks. Connecting the Micro Extender to a LAN hub, switch, repeater, or other network device, or exposing it to the signal levels present on network data lines, is a sure way to blow out the Extender, and could damage other devices attached to the Extender as well.

8.3 Calling Black Box

If you determine that your ServSwitch™ Brand CAT5 KVM Micro Extender is malfunctioning, *do not attempt to alter or repair it*. It contains no user-serviceable parts. Contact Black Box Technical Support at 724-746-5500.

Before you do, make a record of the history of the problem. We will be able to provide more efficient and accurate assistance if you have a complete description, including:

- the firmware-revision level printed on the bottom of the Micro Extender's Local and Remote Units (very important, especially for keyboard and mouse problems);
- the nature and duration of the problem;
- when the problem occurs;
- the components involved in the problem—that is, what type of computers, what type of keyboard, brand of mouse, make and model of monitor, type and make of CAT5 cable, etc.;
- any particular application that, when used, appears to create the problem or make it worse; and
- the results of any testing you've already done.

To solve some problems, it might be necessary to upgrade the Micro Extender's firmware. If this turns out to be the case for your difficulty, our technical support technicians will arrange for you to receive the new firmware and will tell you how to install it.

8.4 Shipping and Packaging

If you need to transport or ship your ServSwitch™ Brand CAT5 KVM Micro Extender:

- Package it carefully. We recommend that you use the original container.
- If you are shipping the unit for repair, please include all parts of its external power supply. If you are returning the unit, please include everything you received with it. Before you ship it back to Black Box for repair or return, contact us to get a Return Authorization (RA) number.

Appendix A: Cable Pinning/Pairing

The cable you will use to interconnect the Local and Remote Units of your ServSwitch™ Brand CAT5 KVM Micro Extender should be terminated with RJ-45 plugs and should be wired according to the EIA/TIA-568 standard (preferably 568B rather than 568A). See **Section 4.2.5** for a more complete set of cable recommendations.

Looking into the interconnect socket on either Micro Extender Unit, or looking at the cable plug from behind, Pin 1 should be on the left and Pin 8 on the right, and the wires should be arranged this way:

| Pin | Color | Function, Pair |
|-----|--------------|----------------|
| 1 | White/Orange | TX, Pair 2 |
| 2 | Orange/White | RX, Pair 2 |
| 3 | White/Green | TX, Pair 3 |
| 4 | Blue/White | RX, Pair 1 |
| 5 | White/Blue | TX, Pair 1 |
| 6 | Green/White | RX, Pair 3 |
| 7 | White/Brown | TX, Pair 4 |
| 8 | Brown/White | RX, Pair 4 |

NOTES

The Micro Extender has been tested with all major makes of CAT5 cable including Black Box, Berk-Tek™, Mohawk®, and AT&T®. The Extender has also been tested and found to work, *in certain situations*, with 4-pair Category 3 cable or with four pairs of 25-pair UTP trunk cables instead of 4-pair Category 5 cable. But we do *not* recommend such installations; if you want to experiment with them, do so at your own risk.

We don't normally recommend using CAT5e cable (rated for up to 155 Mbps), although our EYN795MS cable has performed well in testing. *Avoid* using cables rated "Level 6," "Level 7," etc. If you have problems getting a good picture with CAT5e cable, or if you *must* use cables with bandwidths higher than 155 Mbps, please contact tech support; the signal-skew problems caused by tightly twisted pairs in these cables can sometimes be resolved by swapping which pairs are used for which signals or by using an external delay line.

Appendix B:

Keyboard-Command Summary

Here is a brief list of the keyboard commands you can use to control your ServSwitch™ Brand CAT5 KVM Extender. For detailed descriptions of the commands and the effects they have on the system (including their effects on the keyboard LEDs), refer to **Section 7.3**.

Single-Access Micro Extender (ACU3001A)

| <i>Function:</i> | <i>Keyboard command/activity:</i> |
|--------------------------|----------------------------------------------------------------------------------------|
| Take control of CPU | Press any key on keyboard or move mouse |
| Reset keyboard and mouse | Press and release [Scroll Lock] once |
| Send null byte to mouse | Press and hold left and right mouse buttons, then press and release [Scroll Lock] once |

Dual-Access Micro Extender (ACU3009A)

| <i>Function:</i> | <i>Keyboard command/activity:</i> |
|--------------------------|----------------------------------------------------------------------------------------|
| Take control of CPU | Press any key on keyboard or move mouse |
| Reset keyboard and mouse | Press and release [Scroll Lock] <i>once</i> at Remote Unit, <i>twice</i> at Local Unit |
| Send null byte to mouse | Press and hold left and right mouse buttons, then press and release [Scroll Lock] once |
| Enter Private Mode | <i>At Local Unit only:</i> Press and release [Scroll Lock] <i>once</i> |

KVM/Serial/Audio Micro Extender (ACU3022A)

| <i>Function:</i> | <i>Keyboard command/activity:</i> |
|---------------------------|------------------------------------------------------------------------------------------|
| Take control of local CPU | Press any key on keyboard or move mouse |
| Reset keyboard and mouse | Press and release {hotkey*}, then press and release keypad's up-arrow (number [8]) key |
| Send null byte to mouse | Press and release {hotkey*}, then press and release keypad's left-arrow (number [4]) key |

*The default {hotkey} is right-[Ctrl], but you can set it to left-[Ctrl]; see **Section 5.2**.

DISCLAIMERS

While every precaution has been taken in the preparation of this manual, the manufacturer assumes no responsibility for errors or omissions. Neither does the manufacturer assume any liability for damages resulting from the use of the information contained herein. They reserve the right to change the specifications, functions, or circuitry of the product without notice.

The manufacturer cannot accept liability for damage due to misuse of the product or due to other circumstances outside the manufacturer's control. And the manufacturer will not be responsible for any loss, damage, or injury arising directly or indirectly from the use of this product.

NOTES



REGULAR-1M5

Customer Support Information:

FREE tech support 24 hours a day, 7 days a week: Call **724-746-5500** or fax **724-746-0746**.

Mailing address: **Black Box Corporation**, 1000 Park Dr., Lawrence, PA 15055-1018

World-Wide Web: www.blackbox.com • E-mail: info@blackbox.com

© Copyright 2002. Black Box Corporation. All rights reserved.