

To all our customers

Regarding the change of names mentioned in the document, such as Mitsubishi Electric and Mitsubishi XX, to Renesas Technology Corp.

The semiconductor operations of Hitachi and Mitsubishi Electric were transferred to Renesas Technology Corporation on April 1st 2003. These operations include microcomputer, logic, analog and discrete devices, and memory chips other than DRAMs (flash memory, SRAMs etc.) Accordingly, although Mitsubishi Electric, Mitsubishi Electric Corporation, Mitsubishi Semiconductors, and other Mitsubishi brand names are mentioned in the document, these names have in fact all been changed to Renesas Technology Corp. Thank you for your understanding. Except for our corporate trademark, logo and corporate statement, no changes whatsoever have been made to the contents of the document, and these changes do not constitute any alteration to the contents of the document itself.

Note : Mitsubishi Electric will continue the business operations of high frequency & optical devices and power devices.

Renesas Technology Corp.
Customer Support Dept.
April 1, 2003

MITSUBISHI 4-BIT SINGLE-CHIP MICROCOMPUTER
4500 SERIES

4513/4514
Group

User's Manual

keep safety first in your circuit designs !

- Mitsubishi Electric Corporation puts the maximum effort into making semiconductor products better and more reliable, but there is always the possibility that trouble may occur with them. Trouble with semiconductors may lead to personal injury, fire or property damage. Remember to give due consideration to safety when making your circuit designs, with appropriate measures such as (i) placement of substitutive, auxiliary circuits, (ii) use of non-flammable material or (iii) prevention against any malfunction or mishap.

Notes regarding these materials

- These materials are intended as a reference to assist our customers in the selection of the Mitsubishi semiconductor product best suited to the customer's application; they do not convey any license under any intellectual property rights, or any other rights, belonging to Mitsubishi Electric Corporation or a third party.
- Mitsubishi Electric Corporation assumes no responsibility for any damage, or infringement of any third-party's rights, originating in the use of any product data, diagrams, charts or circuit application examples contained in these materials.
- All information contained in these materials, including product data, diagrams and charts, represent information on products at the time of publication of these materials, and are subject to change by Mitsubishi Electric Corporation without notice due to product improvements or other reasons. It is therefore recommended that customers contact Mitsubishi Electric Corporation or an authorized Mitsubishi Semiconductor product distributor for the latest product information before purchasing a product listed herein.
- Mitsubishi Electric Corporation semiconductors are not designed or manufactured for use in a device or system that is used under circumstances in which human life is potentially at stake. Please contact Mitsubishi Electric Corporation or an authorized Mitsubishi Semiconductor product distributor when considering the use of a product contained herein for any specific purposes, such as apparatus or systems for transportation, vehicular, medical, aerospace, nuclear, or undersea repeater use.
- The prior written approval of Mitsubishi Electric Corporation is necessary to reprint or reproduce in whole or in part these materials.
- If these products or technologies are subject to the Japanese export control restrictions, they must be exported under a license from the Japanese government and cannot be imported into a country other than the approved destination. Any diversion or reexport contrary to the export control laws and regulations of JAPAN and/or the country of destination is prohibited.
- Please contact Mitsubishi Electric Corporation or an authorized Mitsubishi Semiconductor product distributor for further details on these materials or the products contained therein.

Preface

This user's manual describes the hardware and instructions of Mitsubishi's 4513/4514 Group CMOS 4-bit microcomputer.

After reading this manual, the user should have a thorough knowledge of the functions and features of the 4513/4514 Group and should be able to fully utilize the product. The manual starts with specifications and ends with application examples.

In this manual, the 4514 Group is mainly described. The differences from the 4513 Group are described at the related points.

BEFORE USING THIS USER'S MANUAL

This user's manual consists of the following three chapters. Refer to the chapter appropriate to your conditions, such as hardware design or software development.

1. Organization

CHAPTER 1 HARDWARE

This chapter describes features of the microcomputer and operation of each peripheral function.

CHAPTER 2 APPLICATION

This chapter describes usage and application examples of peripheral functions, based mainly on setting examples of related registers.

CHAPTER 3 APPENDIX

This chapter includes precautions for systems development using the microcomputer, the mask ROM confirmation forms (mask ROM version), and mark specification forms which are to be submitted when ordering.

Be sure to refer to this chapter because this chapter also includes necessary information for systems development.

Note: In this manual, the 4514 Group is mainly described. The differences from the 4513 Group are described at the related points.

Table of contents

CHAPTER 1 HARDWARE

DESCRIPTION	1-3
FEATURES	1-3
APPLICATION	1-3
PIN CONFIGURATION	1-4
BLOCK DIAGRAM	1-6
PERFORMANCE OVERVIEW	1-8
PIN DESCRIPTION	1-9
MULTIFUNCTION	1-10
CONNECTIONS OF UNUSED PINS	1-10
PORT FUNCTION	1-11
DEFINITION OF CLOCK AND CYCLE	1-11
PORT BLOCK DIAGRAMS	1-12
FUNCTION BLOCK OPERATIONS	1-17
CPU	1-17
PROGRAM MEMORY (ROM)	1-20
DATA MEMORY (RAM)	1-21
INTERRUPT FUNCTION	1-22
EXTERNAL INTERRUPTS	1-26
TIMERS	1-29
WATCHDOG TIMER	1-35
SERIAL I/O	1-36
A-D CONVERTER	1-41
VOLTAGE COMPARATOR	1-47
RESET FUNCTION	1-49
VOLTAGE DROP DETECTION CIRCUIT	1-52
RAM BACK-UP MODE	1-53
CLOCK CONTROL	1-57
ROM ORDERING METHOD	1-58
LIST OF PRECAUTIONS	1-59
SYMBOL	1-62
LIST OF INSTRUCTION FUNCTION	1-63
INSTRUCTION CODE TABLE	1-66
MACHINE INSTRUCTIONS	1-70
CONTROL REGISTERS	1-84
BUILT-IN PROM VERSION	1-88

CHAPTER 2 APPLICATION

2.1 I/O pins	2-2
2.1.1 I/O ports	2-2
2.1.2 Related registers	2-4
2.1.3 Port application examples	2-7
2.1.4 Notes on use	2-9
2.2 Interrupts	2-11
2.2.1 Interrupt functions	2-11
2.2.2 Related registers	2-13
2.2.3 Interrupt application examples	2-16
2.2.4 Notes on use	2-25
2.3 Timers	2-26
2.3.1 Timer functions	2-26
2.3.2 Related registers	2-27
2.3.3 Timer application examples	2-30
2.3.4 Notes on use	2-39
2.4 Serial I/O	2-40
2.4.1 Carrier functions	2-40
2.4.2 Related registers	2-41
2.4.3 Operation description	2-42
2.4.4 Serial I/O application example	2-45
2.4.5 Notes on use	2-48
2.5 A-D converter	2-49
2.5.1 Related registers	2-50
2.5.2 A-D converter application examples	2-51
2.5.3 Notes on use	2-52
2.6 Voltage comparator	2-54
2.6.1 Voltage comparator function	2-54
2.6.2 Related registers	2-54
2.6.3 Notes on use	2-55
2.7 Reset	2-56
2.7.1 Reset circuit	2-56
2.7.2 Internal state at reset	2-57
2.8 Voltage drop detection circuit	2-58
2.9 RAM back-up	2-59
2.9.1 RAM back-up mode	2-59
2.9.2 Related register	2-60
2.9.3 Notes on use	2-62
2.10 Oscillation circuit	2-63
2.10.1 Oscillation circuit	2-63
2.10.2 Oscillation operation	2-64
2.10.3 Notes on use	2-64

CHAPTER 3 APPENDIX

3.1 Electrical characteristics	3-2
3.1.1 Absolute maximum ratings	3-2
3.1.2 Recommended operating conditions	3-3
3.1.3 Electrical characteristics	3-5
3.1.4 A-D converter recommended operating conditions	3-6
3.1.5 Voltage drop detection circuit characteristics	3-6
3.1.6 Voltage comparator characteristics	3-7
3.1.7 Basic timing diagram	3-7
3.2 Typical characteristics	3-8
3.2.1 VDD–IDD characteristics	3-8
3.2.2 VOL–IOL characteristics	3-11
3.2.3 VOH–IOH characteristics (Port P5)	3-13
3.2.4 VDD–RPU characteristics (Ports P0, P1)	3-13
3.2.5 A-D converter typical characteristics	3-14
3.2.6 Analog input current characteristics pins AIN0–AIN7	3-17
3.2.7 VDD–VIH/VIL characteristics	3-19
3.2.8 Detection voltage temperature characteristics of voltage drop detection circuit	3-20
3.3 List of precautions	3-21
3.4 Notes on noise	3-24
3.4.1 Shortest wiring length	3-24
3.4.2 Connection of bypass capacitor across Vss line and VDD line	3-26
3.4.3 Wiring to analog input pins	3-27
3.4.4 Oscillator concerns	3-27
3.4.5 Setup for I/O ports	3-28
3.4.6 Providing of watchdog timer function by software	3-28
3.5 Mask ROM order confirmation form	3-30
3.6 Mark specification form	3-36
3.7 Package outline	3-39

List of figures

CHAPTER 1 HARDWARE

PIN CONFIGURATION (TOP VIEW) 4513 Group	1-4
PIN CONFIGURATION (TOP VIEW) 4514 Group	1-5
BLOCK DIAGRAM (4513 Group)	1-6
BLOCK DIAGRAM (4514 Group)	1-7
PORT BLOCK DIAGRAMS	1-12
External interrupt circuit structure	1-16
Fig. 1 AMC instruction execution example	1-17
Fig. 2 RAR instruction execution example	1-17
Fig. 3 Registers A, B and register E	1-17
Fig. 4 TABP p instruction execution example	1-17
Fig. 5 Stack registers (SKs) structure	1-18
Fig. 6 Example of operation at subroutine call	1-18
Fig. 7 Program counter (PC) structure	1-19
Fig. 8 Data pointer (DP) structure	1-19
Fig. 9 SD instruction execution example	1-19
Fig. 10 ROM map of M34514M8/E8	1-20
Fig. 11 Page 1 (addresses 0080 ₁₆ to 00FF ₁₆) structure	1-20
Fig. 12 RAM map	1-21
Fig. 13 Program example of interrupt processing	1-23
Fig. 14 Internal state when interrupt occurs	1-23
Fig. 15 Interrupt system diagram	1-23
Fig. 16 Interrupt sequence	1-25
Fig. 17 External interrupt circuit structure	1-26
Fig. 18 Auto-reload function	1-29
Fig. 19 Timers structure	1-31
Fig. 20 Watchdog timer function	1-35
Fig. 21 Program example to enter the RAM back-up mode when using the watchdog timer	1-35
Fig. 22 Serial I/O structure	1-36
Fig. 23 Serial I/O register state when transferring	1-37
Fig. 24 Serial I/O connection example	1-38
Fig. 25 Timing of serial I/O data transfer	1-39
Fig. 26 A-D conversion circuit structure	1-41
Fig. 27 A-D conversion timing chart	1-44
Fig. 28 Setting registers	1-44
Fig. 29 Comparator operation timing chart	1-45
Fig. 30 Definition of A-D conversion accuracy	1-46
Fig. 31 Voltage comparator structure	1-47
Fig. 32 Reset release timing	1-49
Fig. 33 $\overline{\text{RESET}}$ pin input waveform and reset operation	1-49
Fig. 34 Power-on reset circuit example	1-50
Fig. 35 Internal state at reset	1-51
Fig. 36 Voltage drop detection reset circuit	1-52
Fig. 37 Voltage drop detection circuit operation waveform	1-52
Fig. 38 State transition	1-55
Fig. 39 Set source and clear source of the P flag	1-55
Fig. 40 Start condition identified example using the SNZP instruction	1-55
Fig. 41 Clock control circuit structure	1-57

Fig. 42 Ceramic resonator external circuit	1-58
Fig. 43 External clock input circuit	1-58
Fig. 44 External 0 interrupt program example	1-59
Fig. 45 External 1 interrupt program example	1-59
Fig. 46 A-D converter operating mode program example	1-60
Fig. 47 Analog input external circuit example-1	1-60
Fig. 48 Analog input external circuit example-2	1-60
Fig. 49 Pin configuration of built-in PROM version of 4513 Group.....	1-88
Fig. 50 Pin configuration of built-in PROM version of 4514 Group.....	1-88
Fig. 51 PROM memory map.....	1-89
Fig. 52 Flow of writing and test of the product shipped in blank.....	1-89

CHAPTER 2 APPLICATION

Fig. 2.1.1 Key input by key scan.....	2-7
Fig. 2.1.2 Key scan input timing	2-8
Fig. 2.2.1 INT0 interrupt operation example	2-17
Fig. 2.2.2 INT0 interrupt setting example	2-18
Fig. 2.2.3 INT1 interrupt operation example	2-19
Fig. 2.2.4 INT1 interrupt setting example	2-20
Fig. 2.2.5 Timer 1 constant period interrupt setting example.....	2-21
Fig. 2.2.6 Timer 2 constant period interrupt setting example.....	2-22
Fig. 2.2.7 Timer 3 constant period interrupt setting example.....	2-23
Fig. 2.2.8 Timer 4 constant period interrupt setting example.....	2-24
Fig. 2.3.1 Peripheral circuit example	2-30
Fig. 2.3.2 Watchdog timer function.....	2-31
Fig. 2.3.3 Constant period measurement setting example	2-32
Fig. 2.3.4 CNTR0 output setting example	2-33
Fig. 2.3.5 CNTR1 input setting example	2-34
Fig. 2.3.6 CNTR0 output control setting example	2-35
Fig. 2.3.7 Timer start by external input setting example (1)	2-36
Fig. 2.3.8 Timer start by external input setting example (2)	2-37
Fig. 2.3.9 Watchdog timer setting example	2-38
Fig. 2.4.1 Serial I/O block diagram	2-40
Fig. 2.4.2 Serial I/O connection example	2-42
Fig. 2.4.3 Serial I/O register state when transmitting/receiving	2-42
Fig. 2.4.4 Serial I/O transfer timing.....	2-43
Fig. 2.4.5 Master serial I/O setting example	2-46
Fig. 2.4.6 Slave serial I/O example.....	2-47
Fig. 2.4.7 Input waveform of external clock.....	2-48
Fig. 2.5.1 A-D converter structure	2-49
Fig. 2.5.2 A-D conversion mode setting example	2-51
Fig. 2.5.3 Analog input external circuit example-1.....	2-52
Fig. 2.5.4 Analog input external circuit example-2.....	2-52
Fig. 2.5.5 A-D converter operating mode program example.....	2-52
Fig. 2.7.1 Power-on reset circuit example.....	2-56
Fig. 2.7.2 Oscillation stabilizing time after system is released from reset	2-56
Fig. 2.7.3 Internal state at reset	2-57
Fig. 2.8.1 Voltage drop detection reset circuit.....	2-58
Fig. 2.8.2 Voltage drop detection circuit operation waveform	2-58
Fig. 2.9.1 Start condition identified example	2-60
Fig. 2.10.1 Oscillation circuit example connecting ceramic resonator externally.....	2-63
Fig. 2.10.2 Structure of clock control circuit	2-64

CHAPTER 3 APPENDIX

Fig. 3.2.1 A-D conversion characteristics data	3-14
Fig. 44 External 0 interrupt program example	3-21
Fig. 45 External 1 interrupt program example	3-21
Fig. 46 A-D converter operating mode program example	3-22
Fig. 47 Analog input external circuit example-1	3-22
Fig. 48 Analog input external circuit example-2	3-22
Fig. 3.4.1 Selection of packages	3-24
Fig. 3.4.2 Wiring for the $\overline{\text{RESET}}$ input pin	3-24
Fig. 3.4.3 Wiring for clock I/O pins	3-25
Fig. 3.4.4 Wiring for CNVSS pin	3-25
Fig. 3.4.5 Wiring for the VPP pin of the One Time PROM version	3-26
Fig. 3.4.6 Bypass capacitor across the VSS line and the VDD line	3-26
Fig. 3.4.7 Analog signal line and a resistor and a capacitor	3-27
Fig. 3.4.8 Wiring for a large current signal line	3-27
Fig. 3.4.9 Wiring to a signal line where potential levels change frequently	3-28
Fig. 3.4.10 VSS pattern on the underside of an oscillator	3-28
Fig. 3.4.11 Watchdog timer by software	3-29

List of tables

CHAPTER 1 HARDWARE

Table Selection of system clock	1-11
Table 1 ROM size and pages	1-20
Table 2 RAM size	1-21
Table 3 Interrupt sources	1-22
Table 4 Interrupt request flag, interrupt enable bit and skip instruction.....	1-22
Table 5 Interrupt enable bit function	1-22
Table 6 Interrupt control registers	1-24
Table 7 External interrupt activated conditions.....	1-26
Table 8 External interrupt control registers	1-28
Table 9 Function related timers	1-30
Table 10 Timer control registers.....	1-32
Table 11 Serial I/O pins.....	1-36
Table 12 Serial I/O mode register	1-36
Table 13 Processing sequence of data transfer from master to slave	1-40
Table 14 A-D converter characteristics	1-41
Table 15 A-D control registers	1-42
Table 16 Change of successive comparison register AD during A-D conversion.....	1-43
Table 17 Voltage comparator characteristics	1-47
Table 18 Voltage comparator control register Q3	1-48
Table 19 Port state at reset	1-50
Table 20 Functions and states retained at RAM back-up	1-53
Table 21 Return source and return condition	1-54
Table 22 Key-on wakeup control register, pull-up control register, and interrupt control .	1-56
Table 23 Clock control register MR	1-57
Table 24 Maximum value of external clock oscillation frequency.....	1-58
Table 25 Product of built-in PROM version	1-88
Table 26 Programming adapters.....	1-89

CHAPTER 2 APPLICATION

Table 2.1.1 Pull-up control register PU0	2-4
Table 2.1.2 Key-on wakeup control register K0	2-5
Table 2.1.3 A-D control register Q2	2-5
Table 2.1.4 Direction register FR0	2-6
Table 2.1.5 Timer control register W6	2-6
Table 2.1.6 connections of unused pins	2-10
Table 2.2.1 Interrupt control register V1.....	2-14
Table 2.2.2 Interrupt control register V2.....	2-14
Table 2.2.3 Interrupt control register I1	2-15
Table 2.2.4 Interrupt control register I2.....	2-15
Table 2.3.1 Interrupt control register V1.....	2-27
Table 2.3.2 Interrupt control register V2.....	2-27
Table 2.3.3 Timer control register W1	2-28
Table 2.3.4 Timer control register W2	2-28
Table 2.3.5 Timer control register W3.....	2-29
Table 2.3.6 Timer control register W4	2-29
Table 2.4.1 Serial I/O mode register J1	2-41
Table 2.4.2 Recommended operating conditions (serial I/O).....	2-48

Table 2.5.1 A-D control register Q1	2-50
Table 2.5.2 A-D control register Q2	2-50
Table 2.5.3 Recommended operating conditions (when using A-D converter)	2-53
Table 2.6.1 Voltage comparator control register Q3.....	2-54
Table 2.9.1 Functions and states retained at RAM back-up mode	2-59
Table 2.9.2 Return source and return condition.....	2-60
Table 2.9.3 Start condition identification.....	2-60
Table 2.9.4 Key-on wakeup control register K0	2-60
Table 2.9.5 Pull-up control register PU0	2-61
Table 2.9.6 Interrupt control register I1	2-61
Table 2.9.7 Interrupt control register I2.....	2-62
Table 2.10.1 Maximum value of oscillation frequency and supply voltage	2-63

CHAPTER 3 APPENDIX

Table 3.1.1 Absolute maximum ratings	3-2
Table 3.1.2 Recommended operating conditions 1	3-3
Table 3.1.3 Recommended operating conditions 2	3-4
Table 3.1.4 Electrical characteristics	3-5
Table 3.1.5 A-D converter recommended operating conditions.....	3-6
Table 3.1.6 A-D converter characteristics	3-6
Table 3.1.7 Voltage drop detection circuit characteristics.....	3-6
Table 3.1.8 Voltage comparator recommended operating conditions.....	3-7
Table 3.1.9 Voltage comparator characteristics	3-7



CHAPTER 1

HARDWARE

DESCRIPTION
FEATURES
APPLICATION
PIN CONFIGURATION
BLOCK DIAGRAM
PERFORMANCE OVERVIEW
PIN DESCRIPTION
FUNCTION BLOCK OPERATIONS
ROM ORDERING METHOD
LIST OF PRECAUTIONS
SYMBOL
LIST OF INSTRUCTION FUNCTION
INSTRUCTION CODE TABLE
MACHINE INSTRUCTIONS
CONTROL REGISTERS
BUILT-IN PROM VERSION

HARDWARE

DESCRIPTION

The 4513/4514 Group is a 4-bit single-chip microcomputer designed with CMOS technology. Its CPU is that of the 4500 series using a simple, high-speed instruction set. The computer is equipped with serial I/O, four 8-bit timers (each timer has a reload register), and 10-bit A-D converter.

The various microcomputers in the 4513/4514 Group include variations of the built-in memory type and package as shown in the table below.

FEATURES

- Minimum instruction execution time 0.75 μ s
(at 4.0 MHz oscillation frequency, in high-speed mode, VDD = 4.0 V to 5.5 V)
- Supply voltage
 - Middle-speed mode
 - 2.5 V to 5.5 V (at 4.2 MHz oscillation frequency, for Mask ROM version and One Time PROM version)
 - 2.0 V to 5.5 V (at 3.0 MHz oscillation frequency, for Mask ROM version)
(Operation voltage of A-D conversion: 2.7 V to 5.5 V)
 - High-speed mode
 - 4.0 V to 5.5 V (at 4.2 MHz oscillation frequency, for Mask ROM version and One Time PROM version)
 - 2.5 V to 5.5 V (at 2.0 MHz oscillation frequency, for Mask ROM version and One Time PROM version)
 - 2.0 V to 5.5 V (at 1.5 MHz oscillation frequency, for Mask ROM version)
(Operation voltage of A-D conversion: 2.7 V to 5.5 V)

- Timers
 - Timer 1 8-bit timer with a reload register
 - Timer 2 8-bit timer with a reload register
 - Timer 3 8-bit timer with a reload register
 - Timer 4 8-bit timer with a reload register
- Interrupt 8 sources
- Serial I/O 8 bit-wide
- A-D converter 10-bit successive comparison method
- Voltage comparator 2 circuits
- Watchdog timer 16 bits
- Voltage drop detection circuit
- Clock generating circuit (ceramic resonator)
- LED drive directly enabled (port D)

APPLICATION

Electrical household appliance, consumer electronic products, office automation equipment, etc.

Product	ROM (PROM) size (X 10 bits)	RAM size (X 4 bits)	Package	ROM type
M34513M2-XXXSP/FP	2048 words	128 words	SP: 32P4B FP: 32P6B-A	Mask ROM
M34513M4-XXXSP/FP	4096 words	256 words	SP: 32P4B FP: 32P6B-A	Mask ROM
M34513E4SP/FP (Note)	4096 words	256 words	SP: 32P4B FP: 32P6B-A	One Time PROM
M34513M6-XXXFP	6144 words	384 words	32P6B-A	Mask ROM
M34513M8-XXXFP	8192 words	384 words	32P6B-A	Mask ROM
M34513E8FP (Note)	8192 words	384 words	32P6B-A	One Time PROM
M34514M6-XXXFP	6144 words	384 words	42P2R-A	Mask ROM
M34514M8-XXXFP	8192 words	384 words	42P2R-A	Mask ROM
M34514E8FP (Note)	8192 words	384 words	42P2R-A	One Time PROM

Note: shipped in blank

HARDWARE

PIN CONFIGURATION

PIN CONFIGURATION (TOP VIEW) 4513 Group

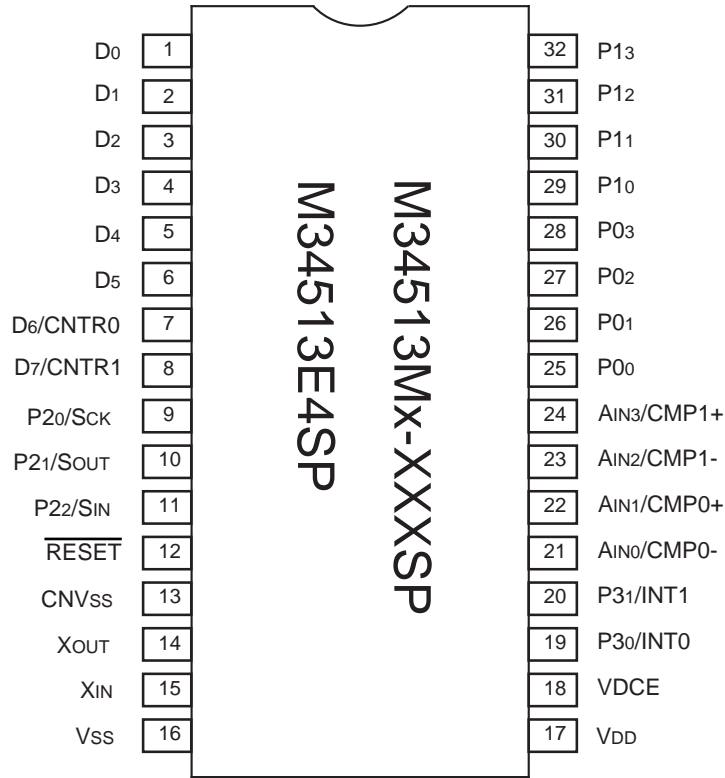

Outline 32P4B

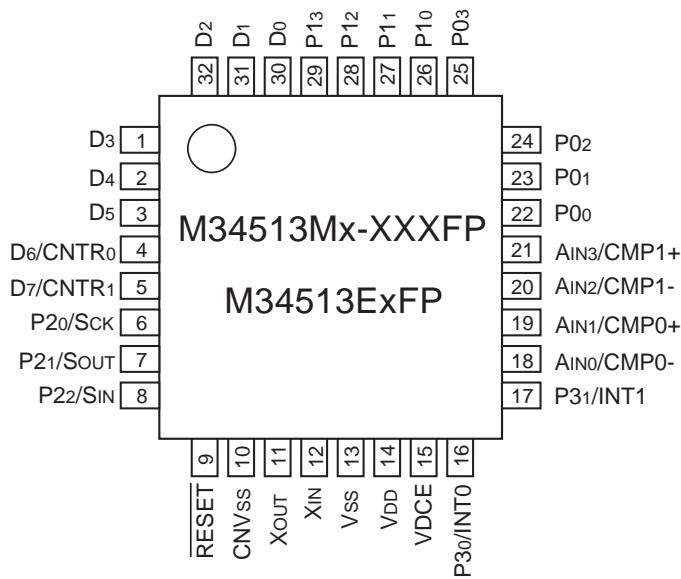

Outline 32P6B-A

PIN CONFIGURATION (TOP VIEW) 4514 Group

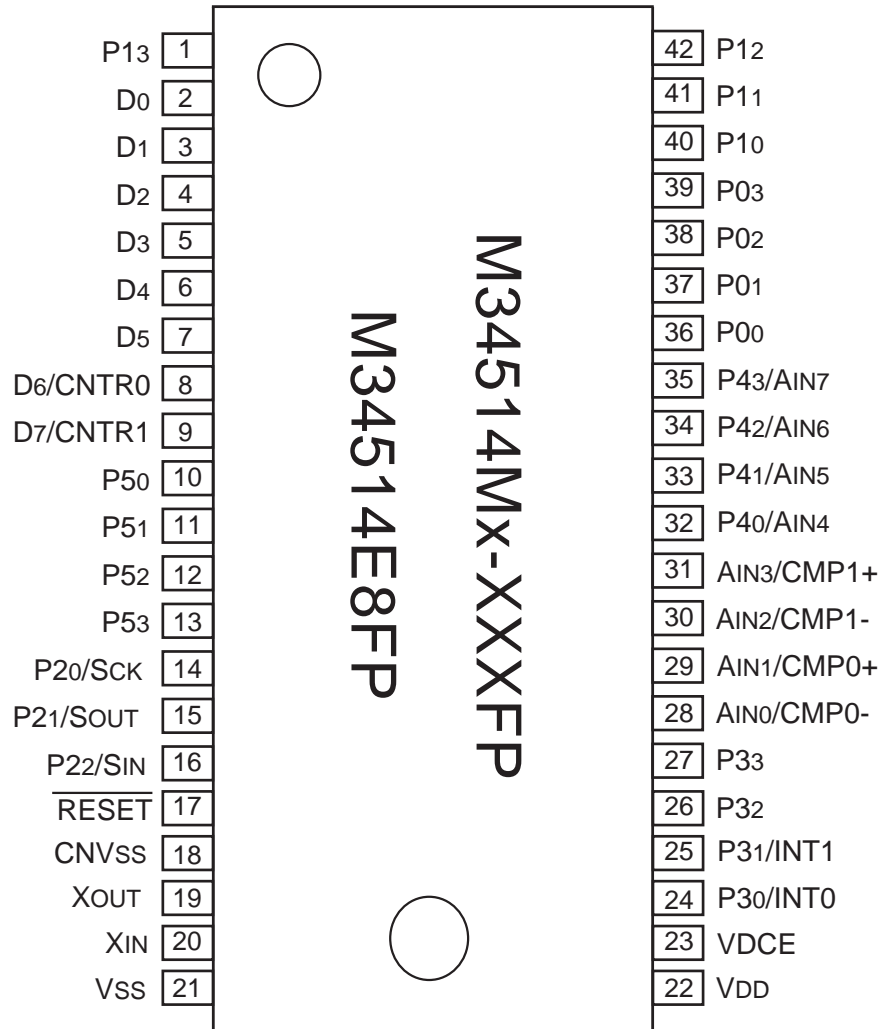

Outline 42P2R-A

HARDWARE

BLOCK DIAGRAM

BLOCK DIAGRAM (4513 Group)

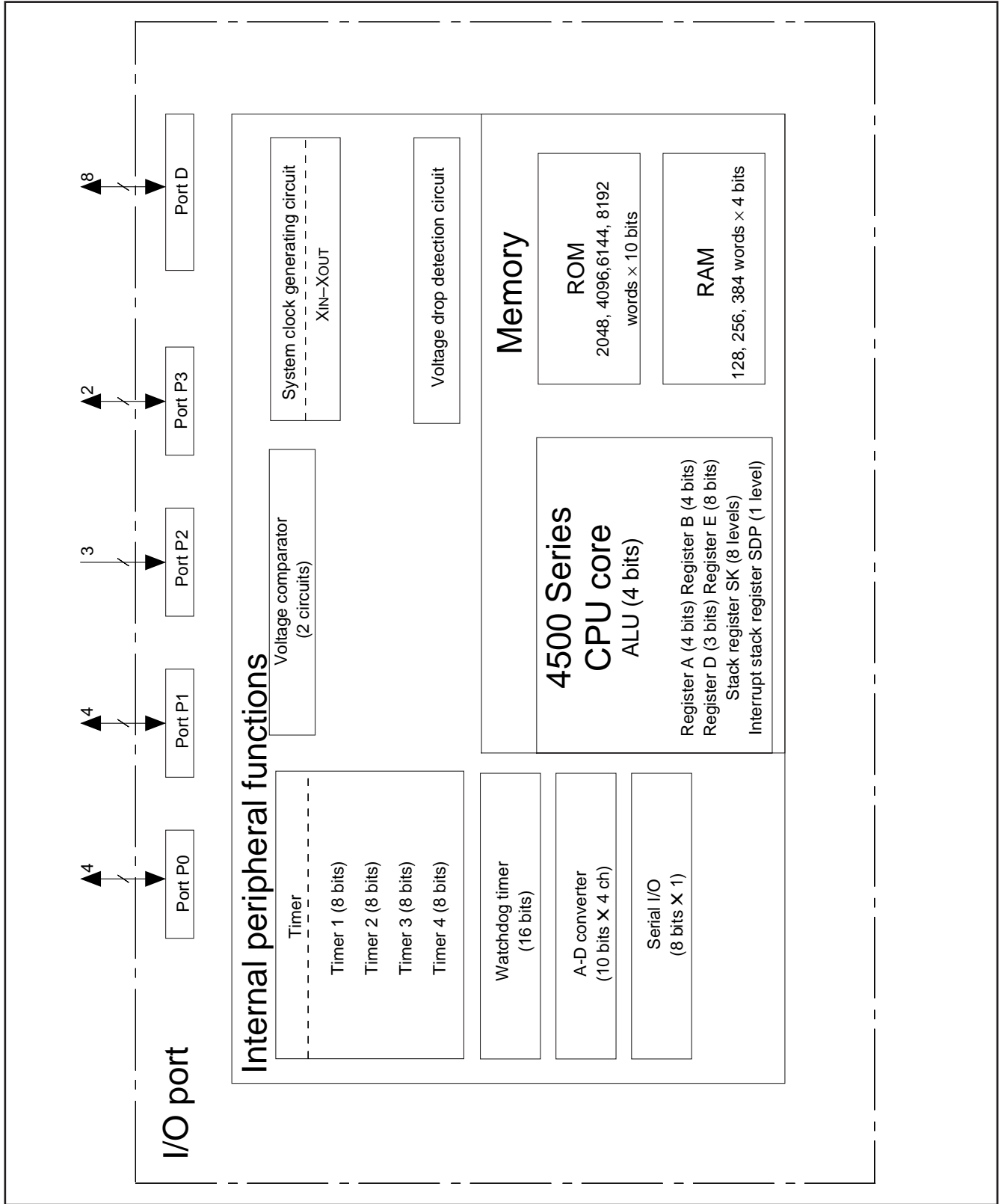

BLOCK DIAGRAM (4514 Group)

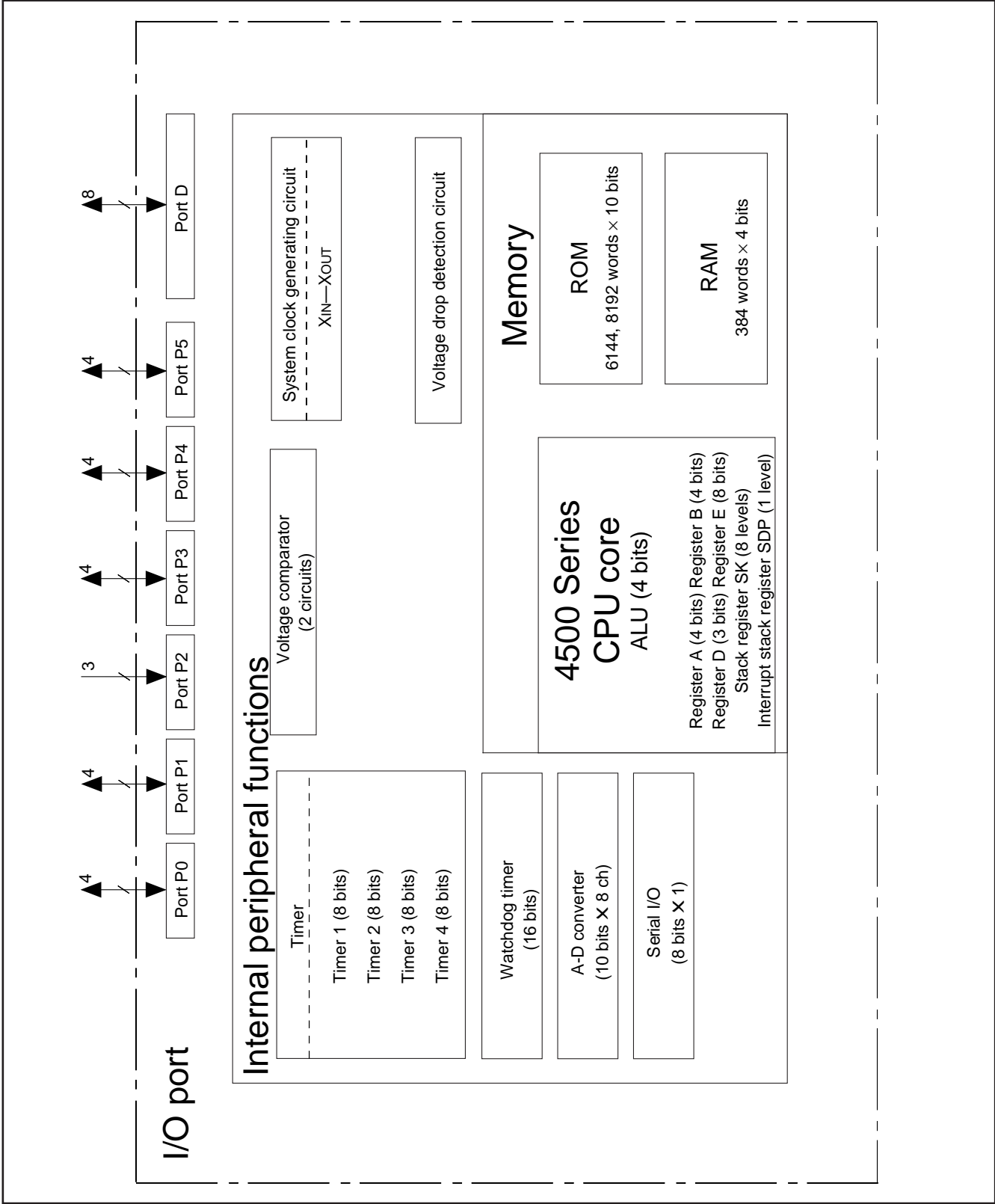

HARDWARE

PERFORMANCE OVERVIEW

PERFORMANCE OVERVIEW

Parameter		Function	
Number of basic instructions	4513 Group	123	
	4514 Group	128	
Minimum instruction execution time		0.75 μ s (at 4.0 MHz oscillation frequency, in high-speed mode)	
Memory sizes	ROM	M34513M2	2048 words \times 10 bits
		M34513M4/E4	4096 words \times 10 bits
		M34513M6	6144 words \times 10 bits
		M34513M8/E8	8192 words \times 10 bits
		M34514M6	6144 words \times 10 bits
		M34514M8/E8	8192 words \times 10 bits
	RAM	M34513M2	128 words \times 4 bits
		M34513M4/E4	256 words \times 4 bits
		M34513M6	384 words \times 4 bits
		M34513M8/E8	384 words \times 4 bits
		M34514M6	384 words \times 4 bits
		M34514M8/E8	384 words \times 4 bits
Input/Output ports	D0–D7	I/O (Input is examined by skip decision)	Eight independent I/O ports; ports D6 and D7 are also used as CNTR0 and CNTR1, respectively.
	P00–P03	I/O	4-bit I/O port; each pin is equipped with a pull-up function and a key-on wakeup function. Both functions can be switched by software.
	P10–P13	I/O	4-bit I/O port; each pin is equipped with a pull-up function and a key-on wakeup function. Both functions can be switched by software.
	P20–P22	Input	3-bit input port; ports P20, P21 and P22 are also used as SCK, SOUT and SIN, respectively.
	P30–P33	I/O	4-bit I/O port (2-bit I/O port for the 4513 Group); ports P30 and P31 are also used as INT0 and INT1, respectively. The 4513 Group does not have ports P32, P33.
	P40–P43	I/O	4-bit I/O port; The 4513 Group does not have this port.
	P50–P53	I/O	4-bit I/O port with a direction register; The 4513 Group does not have this port.
	CNTR0	I/O	1-bit I/O; CNTR0 pin is also used as port D6.
	CNTR1	I/O	1-bit I/O; CNTR1 pin is also used as port D7.
	INT0	Input	1-bit input; INT0 pin is also used as port P30 and equipped with a key-on wakeup function.
	INT1	Input	1-bit input; INT1 pin is also used as port P31 and equipped with a key-on wakeup function.
Timers	Timer 1		8-bit programmable timer with a reload register.
	Timer 2		8-bit programmable timer with a reload register is also used as an event counter.
	Timer 3		8-bit programmable timer with a reload register.
	Timer 4		8-bit programmable timer with a reload register is also used as an event counter.
A-D converter		10-bit wide, This is equipped with an 8-bit comparator function.	
Voltage comparator		2 circuits (CMP0, CMP1)	
Serial I/O		8-bit \times 1	
Interrupt	Sources		8 (two for external, four for timer, one for A-D, and one for serial I/O)
	Nesting		1 level
Subroutine nesting			8 levels
Device structure			CMOS silicon gate
Package	4513 Group		32-pin plastic molded SDIP (32P4B)/LQFP(32P6B-A)
	4514 Group		42-pin plastic molded SSOP (42P2R-A)
Operating temperature range			–20 °C to 85 °C
Supply voltage			2.0 V to 5.5 V for Mask ROM version, 2.5 V to 5.5 V for One Time PROM version (Refer to the electrical characteristics because the supply voltage depends on the oscillation frequency.)
Power dissipation (typical value)	Active mode		1.8 mA (at V _{DD} = 5.0 V, 4.0 MHz oscillation frequency, in middle-speed mode, output transistors in the cut-off state)
			3.0 mA (at V _{DD} = 5.0 V, 4.0 MHz oscillation frequency, in high-speed mode, output transistors in the cut-off state)
	RAM back-up mode		0.1 μ A (at room temperature, V _{DD} = 5 V, output transistors in the cut-off state)

PIN DESCRIPTION

Pin	Name	Input/Output	Function
VDD	Power supply	—	Connected to a plus power supply.
VSS	Ground	—	Connected to a 0 V power supply.
VDCE	Voltage drop detection circuit enable	Input	VDCE pin is used to control the operation/stop of the voltage drop detection circuit. When “H” level is input to this pin, the circuit is operating. When “L” level is input to this pin, the circuit is stopped.
CNVSS	CNVSS	—	Connect CNVSS to VSS and apply “L” (0V) to CNVSS certainly.
RESET	Reset input	I/O	An N-channel open-drain I/O pin for a system reset. When the watchdog timer causes the system to be reset or system reset is performed by the voltage drop detection circuit, the RESET pin outputs “L” level.
XIN	System clock input	Input	I/O pins of the system clock generating circuit. XIN and XOUT can be connected to ceramic resonator. A feedback resistor is built-in between them.
XOUT	System clock output	Output	
D0–D7	I/O port D (Input is examined by skip decision.)	I/O	Each pin of port D has an independent 1-bit wide I/O function. Each pin has an output latch. For input use, set the latch of the specified bit to “1.” The output structure is N-channel open-drain. Ports D6 and D7 are also used as CNTR0 and CNTR1, respectively.
P00–P03	I/O port P0	I/O	Each of ports P0 and P1 serves as a 4-bit I/O port, and it can be used as inputs when the output latch is set to “1.” The output structure is N-channel open-drain. Every pin of the ports has a key-on wakeup function and a pull-up function. Both functions can be switched by software.
P10–P13	I/O port P1	I/O	
P20–P22	Input port P2	Input	3-bit input port. Ports P20, P21 and P22 are also used as SCK, SOUT and SIN, respectively.
P30–P33	I/O port P3	I/O	4-bit I/O port (2-bit I/O port for the 4513 Group). For input use, set the latch of the specified bit to “1.” The output structure is N-channel open-drain. Ports P30 and P31 are also used as INT0 and INT1, respectively. The 4513 Group does not have ports P32, P33.
P40–P43	I/O port P4	I/O	4-bit I/O port. For input use, set the latch of the specified bit to “1.” The output structure is N-channel open-drain. Ports P40–P43 are also used as analog input pins AIN4–AIN7, respectively. The 4513 Group does not have port P4.
P50–P53	I/O port P5	I/O	4-bit I/O port. Each pin has a direction register and an independent 1-bit wide I/O function. For input use, set the direction register to “0.” For output use, set the direction register to “1.” The output structure is CMOS. The 4513 Group does not have port P5.
AIN0–AIN7	Analog input	Input	Analog input pins for A-D converter. AIN0–AIN3 are also used as voltage comparator input pins and AIN4–AIN7 are also used as port P4. The 4513 Group does not have AIN4–AIN7.
CNTR0	Timer input/output	I/O	CNTR0 pin has the function to input the clock for the timer 2 event counter, and to output the timer 1 underflow signal divided by 2. CNTR0 pin is also used as port D6.
CNTR1	Timer input/output	I/O	CNTR1 pin has the function to input the clock for the timer 4 event counter, and to output the timer 3 underflow signal divided by 2. CNTR1 pin is also used as port D7.
INT0, INT1	Interrupt input	Input	INT0, INT1 pins accept external interrupts. They also accept the input signal to return the system from the RAM back-up state. INT0, INT1 pins are also used as ports P30 and P31, respectively.
SIN	Serial data input	Input	SIN pin is used to input serial data signals by software. SIN pin is also used as port P22.
SOUT	Serial data output	Output	SOUT pin is used to output serial data signals by software. SOUT pin is also used as port P21.
SCK	Serial I/O clock input/output	I/O	SCK pin is used to input and output synchronous clock signals for serial data transfer by software. SCK pin is also used as port P20.
CMP0- CMP0+	Voltage comparator input	Input	CMP0-, CMP0+ pins are used as the voltage comparator input pin when the voltage comparator function is selected by software. CMP0-, CMP0+ pins are also used as AIN0 and AIN1.
CMP1- CMP1+	Voltage comparator input	Input	CMP1-, CMP1+ pins are used as the voltage comparator input pin when the voltage comparator function is selected by software. CMP1-, CMP1+ pins are also used as AIN2 and AIN3.

HARDWARE

PIN DESCRIPTION

MULTIFUNCTION

Pin	Multifunction	Pin	Multifunction	Pin	Multifunction	Pin	Multifunction
D6	CNTR0	CNTR0	D6	AIN0	CMP0-	CMP0-	AIN0
D7	CNTR1	CNTR1	D7	AIN1	CMP0+	CMP0+	AIN1
P20	SCK	SCK	P20	AIN2	CMP1-	CMP1-	AIN2
P21	SOUT	SOUT	P21	AIN3	CMP1+	CMP1+	AIN3
P22	SIN	SIN	P22	P40	AIN4	AIN4	P40
P30	INT0	INT0	P30	P41	AIN5	AIN5	P41
P31	INT1	INT1	P31	P42	AIN6	AIN6	P42
				P43	AIN7	AIN7	P43

Notes 1: Pins except above have just single function.

- 2: The input of D6, D7, P20–P22, CMP0-, CMP0+, CMP1-, CMP1+ and the input/output of P30, P31, P40–P43 can be used even when CNTR0, CNTR1, SCK, SOUT, SIN, INT0, INT1, and AIN0–AIN7 are selected.
- 3: The 4513 Group does not have P40/AIN4–P43/AIN7.

CONNECTIONS OF UNUSED PINS

Pin	Connection
XOUT	Open (when using an external clock).
VDCE	Connect to VSS.
D0–D5 D6/CNTR0 D7/CNTR1	Connect to VSS, or set the output latch to "0" and open.
P20/SCK P21/SOUT P22/SIN	Connect to VSS.
P30/INT0 P31/INT1 P32, P33	Connect to VSS, or set the output latch to "0" and open.
P40/AIN4–P43/AIN7	Connect to VSS, or set the output latch to "0" and open.
P50–P53 (Note 1)	When the input mode is selected by software, pull-up to VDD through a resistor or pull-down to VDD. When selecting the output mode, open.
AIN0/CMP0- AIN1/CMP0+ AIN2/CMP1- AIN3/CMP1+	Connect to VSS.
P00–P03	Open or connect to VSS (Note 2)
P10–P13	Open or connect to VSS (Note 2)

Notes 1: After system is released from reset, port P5 is in an input mode (direction register FR0 = 00002)

- 2: When the P00–P03 and P10–P13 are connected to VSS, turn off their pull-up transistors (register PU0i="0") and also invalidate the key-on wakeup functions (register K0i="0") by software. When these pins are connected to VSS while the key-on wakeup functions are left valid, the system fails to return from RAM back-up state. When these pins are open, turn on their pull-up transistors (register PU0i="1") by software, or set the output latch to "0." Be sure to select the key-on wakeup functions and the pull-up functions with every two pins. If only one of the two pins for the key-on wakeup function is used, turn on their pull-up transistors by software and also disconnect the other pin. (i = 0, 1, 2, or 3.)

(Note when the output latch is set to "0" and pins are open)

- After system is released from reset, port is in a high-impedance state until it is set the output latch to "0" by software. Accordingly, the voltage level of pins is undefined and the excess of the supply current may occur while the port is in a high-impedance state.
- To set the output latch periodically by software is recommended because value of output latch may change by noise or a program run away (caused by noise).

(Note when connecting to VSS and VDD)

- Connect the unused pins to VSS and VDD using the thickest wire at the shortest distance against noise.

PORT FUNCTION

Port	Pin	Input Output	Output structure	I/O unit	Control instructions	Control registers	Remark
Port D	D0–D5	I/O (8)	N-channel open-drain	1	SD, RD SZD CLD	W6	
	D6/CNTR0						
	D7/CNTR1						
Port P0	P00–P03	I/O (4)	N-channel open-drain	4	OP0A IAP0	PU0, K0	Built-in programmable pull-up functions Key-on wakeup functions (programmable)
Port P1	P10–P13	I/O (4)	N-channel open-drain	4	OP1A IAP1	PU0, K0	Built-in programmable pull-up functions Key-on wakeup functions (programmable)
Port P2	P20/SCK P21/SOUT P22/SIN	Input (3)		3	IAP2	J1	
Port P3 (Note 1)	P30/INT0 P31/INT1 P32, P33	I/O (4)	N-channel open-drain	4	OP3A IAP3	I1, I2	Built-in key-on wakeup function (P30/INT0, P31/INT1)
Port P4 (Note 2)	P40/AIN4 –P43/AIN7	I/O (4)	N-channel open-drain	4	OP4A IAP4	Q2	
Port P5 (Note 2)	P50–P53	I/O (4)	CMOS	4	OP5A IAP5	FR0	

Notes 1: The 4513 Group does not have P32 and P33.

2: The 4513 Group does not have these ports.

DEFINITION OF CLOCK AND CYCLE

- System clock

The system clock is the basic clock for controlling this product.

The system clock is selected by the bit 3 of the clock control register MR.

Table Selection of system clock

Register MR MR3	System clock
0	f(XIN)
1	f(XIN)/2

Note: f(XIN)/2 is selected after system is released from reset.

- Instruction clock

The instruction clock is a signal derived by dividing the system clock by 3. The one instruction clock cycle generates the one machine cycle.

- Machine cycle

The machine cycle is the standard cycle required to execute the instruction.

HARDWARE

PIN DESCRIPTION

PORT BLOCK DIAGRAMS

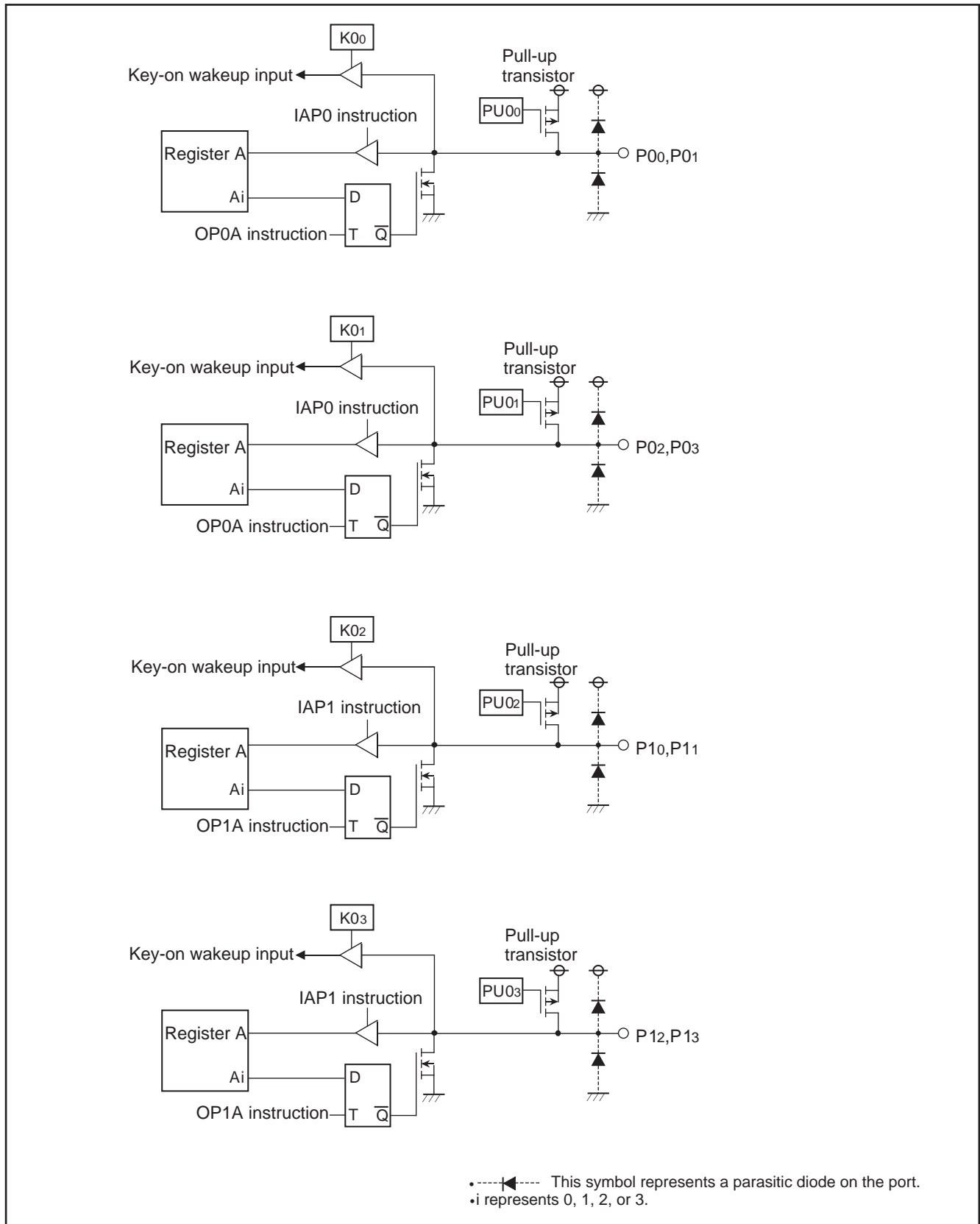

PORT BLOCK DIAGRAMS (continued)

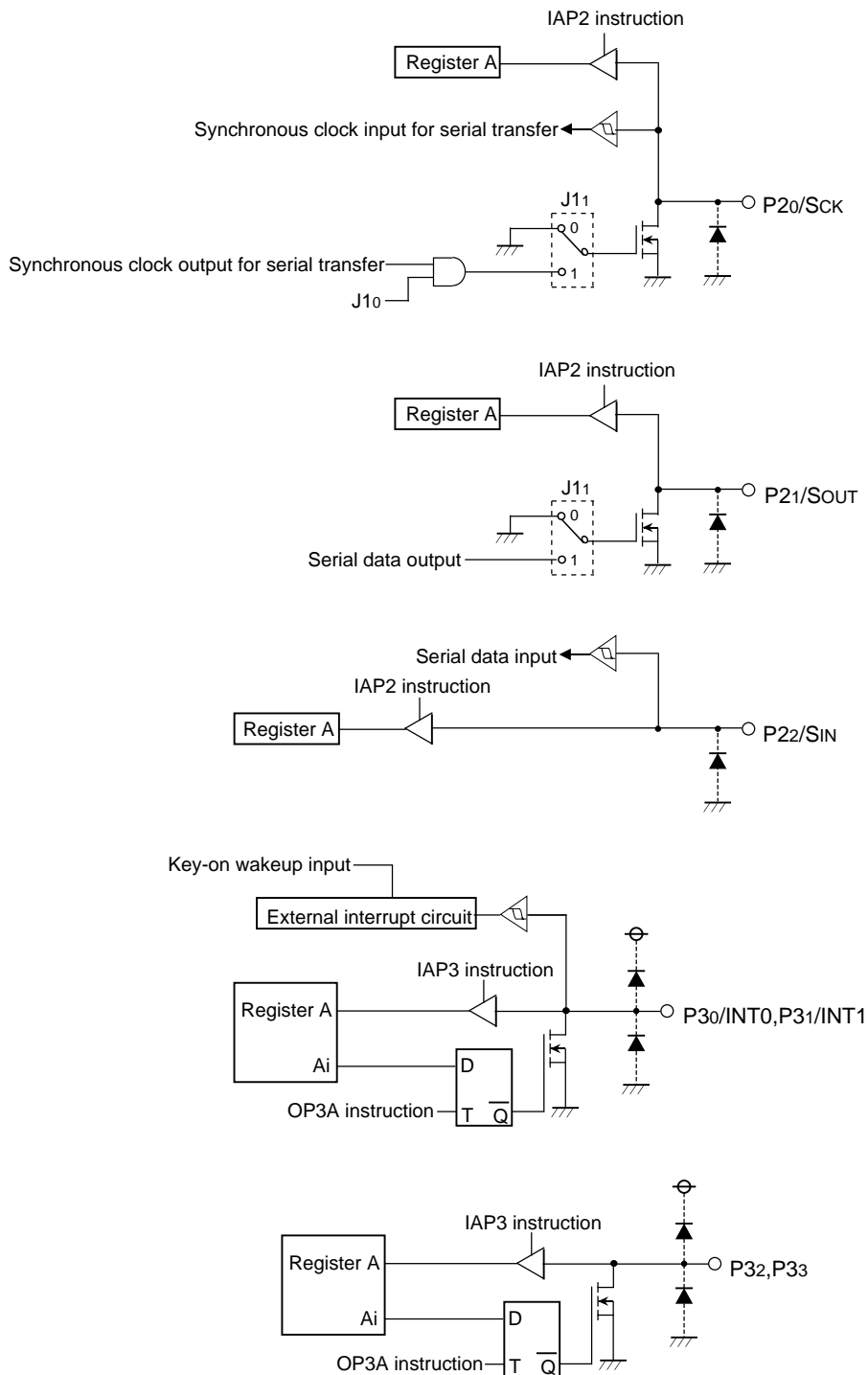

- This symbol represents a parasitic diode on the port.
- Applied potential to ports P20—P22 must be VDD.
- i represents 0, 1, 2, or 3.
- The 4513 Group does not have ports P32, P33.

HARDWARE

PIN DESCRIPTION

PORT BLOCK DIAGRAMS (continued)

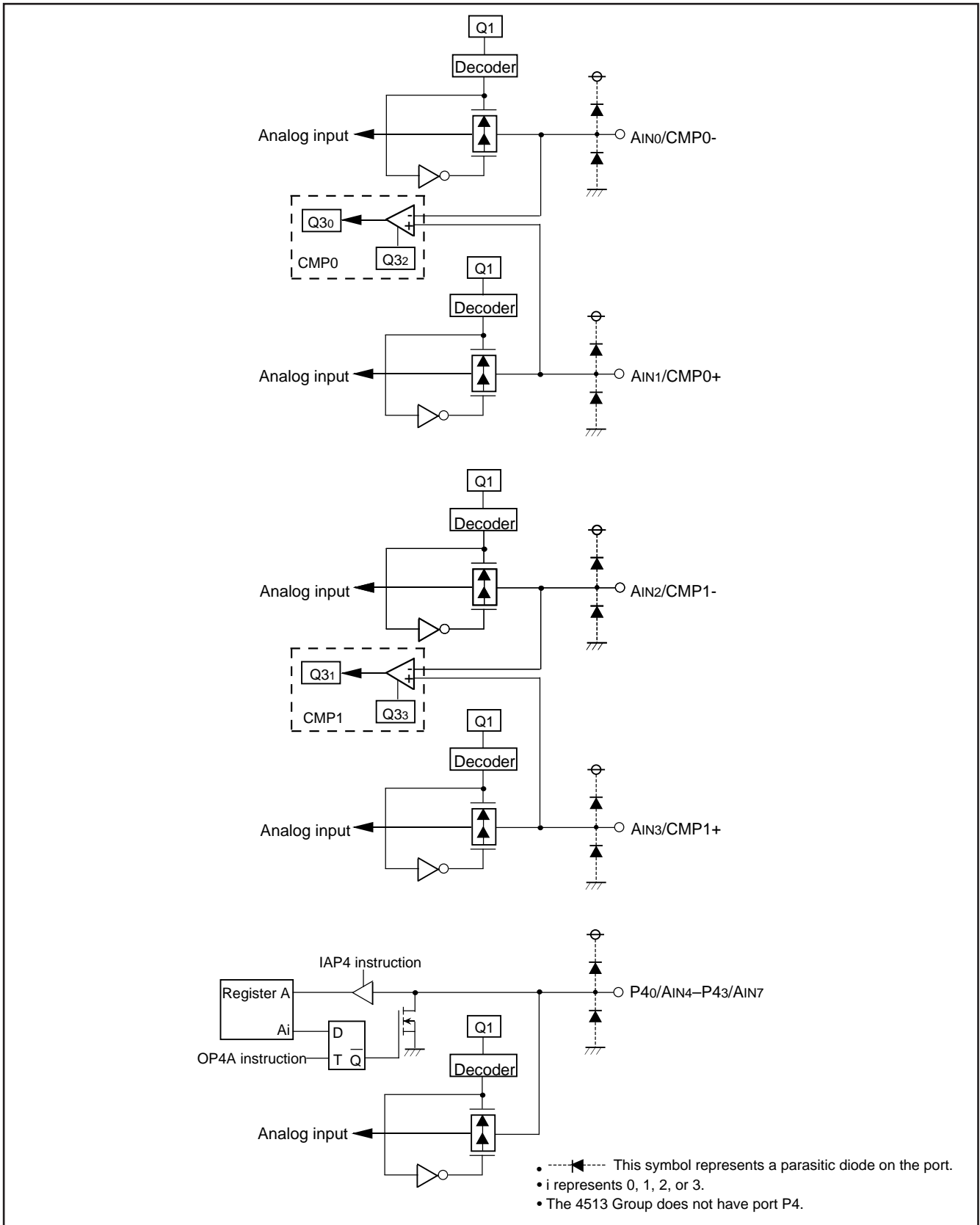

PORT BLOCK DIAGRAMS (continued)

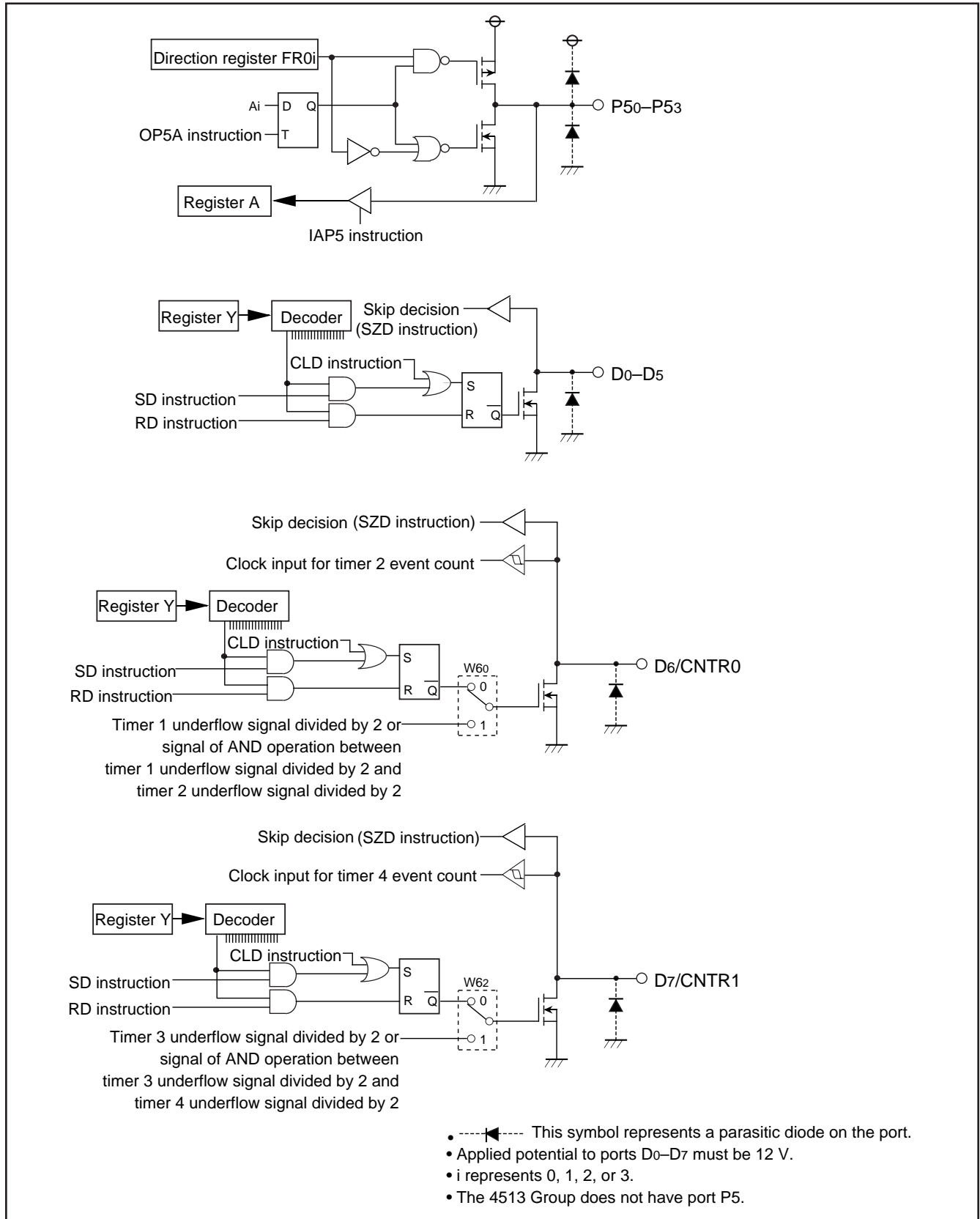

HARDWARE

PIN DESCRIPTION

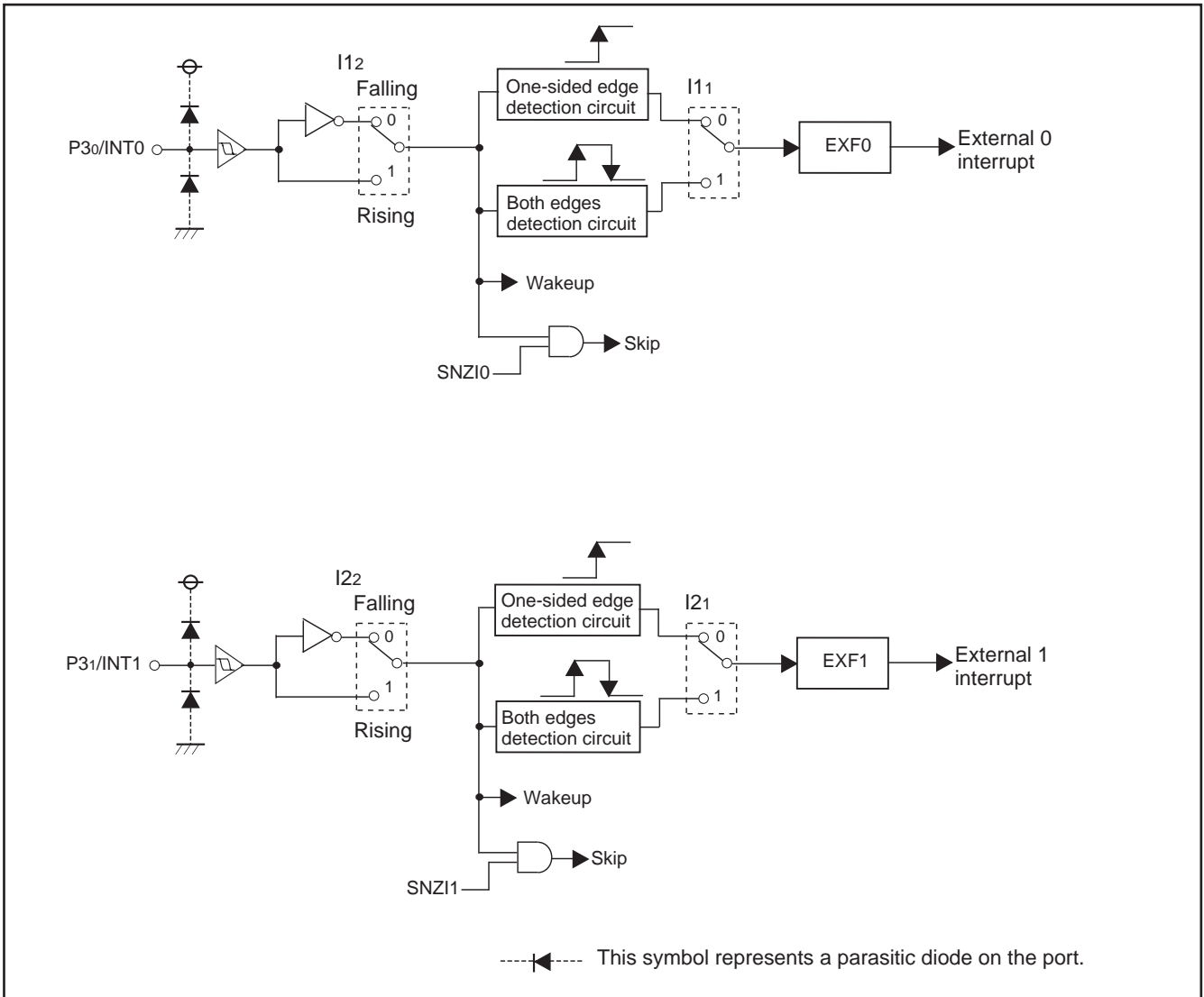

External interrupt circuit structure

FUNCTION BLOCK OPERATIONS CPU

(1) Arithmetic logic unit (ALU)

The arithmetic logic unit ALU performs 4-bit arithmetic such as 4-bit data addition, comparison, AND operation, OR operation, and bit manipulation.

(2) Register A and carry flag

Register A is a 4-bit register used for arithmetic, transfer, exchange, and I/O operation.

Carry flag CY is a 1-bit flag that is set to "1" when there is a carry with the AMC instruction (Figure 1).

It is unchanged with both A n instruction and AM instruction. The value of A₀ is stored in carry flag CY with the RAR instruction (Figure 2).

Carry flag CY can be set to "1" with the SC instruction and cleared to "0" with the RC instruction.

(3) Registers B and E

Register B is a 4-bit register used for temporary storage of 4-bit data, and for 8-bit data transfer together with register A.

Register E is an 8-bit register. It can be used for 8-bit data transfer with register B used as the high-order 4 bits and register A as the low-order 4 bits (Figure 3).

(4) Register D

Register D is a 3-bit register.

It is used to store a 7-bit ROM address together with register A and is used as a pointer within the specified page when the TABP p, BLA p, or BMLA p instruction is executed (Figure 4).

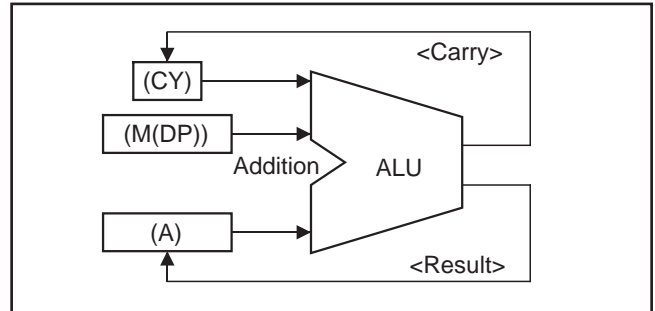

Fig. 1 AMC instruction execution example

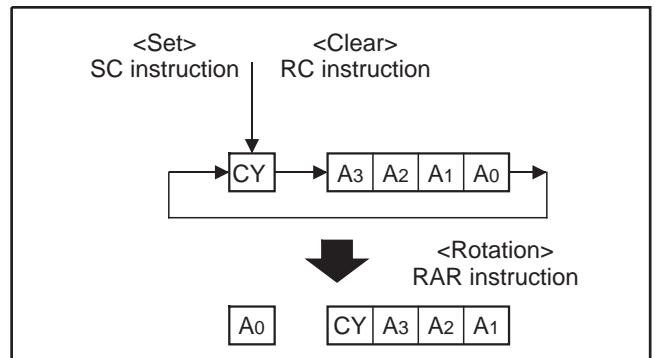

Fig. 2 RAR instruction execution example

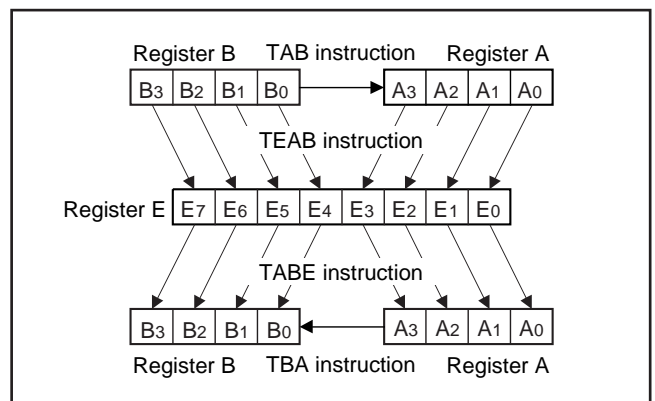

Fig. 3 Registers A, B and register E

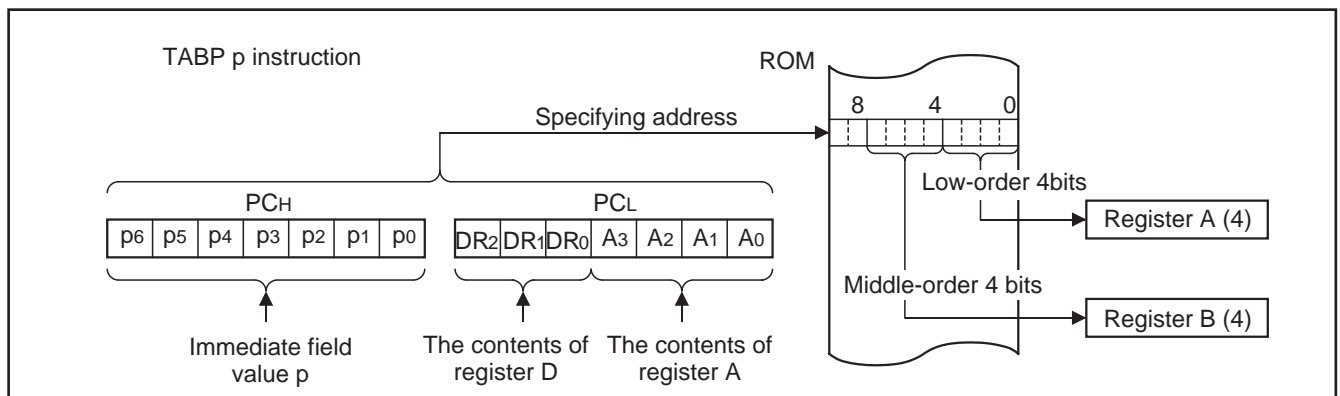

Fig. 4 TABP p instruction execution example

HARDWARE

FUNCTION BLOCK OPERATIONS

(5) Stack registers (SKs) and stack pointer (SP)

Stack registers (SKs) are used to temporarily store the contents of program counter (PC) just before branching until returning to the original routine when;

- branching to an interrupt service routine (referred to as an interrupt service routine),
- performing a subroutine call, or
- executing the table reference instruction (TABP p).

Stack registers (SKs) are eight identical registers, so that subroutines can be nested up to 8 levels. However, one of stack registers is used respectively when using an interrupt service routine and when executing a table reference instruction. Accordingly, be careful not to over the stack when performing these operations together. The contents of registers SKs are destroyed when 8 levels are exceeded.

The register SK nesting level is pointed automatically by 3-bit stack pointer (SP). The contents of the stack pointer (SP) can be transferred to register A with the TASP instruction.

Figure 5 shows the stack registers (SKs) structure.

Figure 6 shows the example of operation at subroutine call.

(6) Interrupt stack register (SDP)

Interrupt stack register (SDP) is a 1-stage register. When an interrupt occurs, this register (SDP) is used to temporarily store the contents of data pointer, carry flag, skip flag, register A, and register B just before an interrupt until returning to the original routine.

Unlike the stack registers (SKs), this register (SDP) is not used when executing the subroutine call instruction and the table reference instruction.

(7) Skip flag

Skip flag controls skip decision for the conditional skip instructions and continuous described skip instructions. When an interrupt occurs, the contents of skip flag is stored automatically in the interrupt stack register (SDP) and the skip condition is retained.

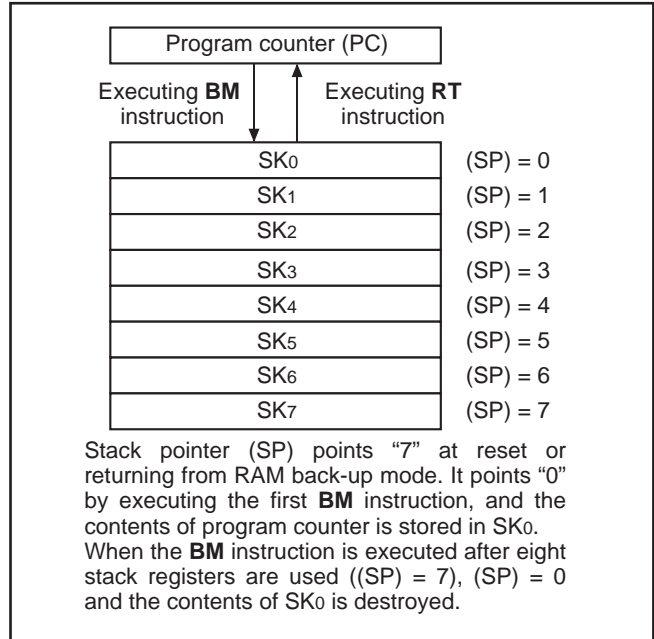

Fig. 5 Stack registers (SKs) structure

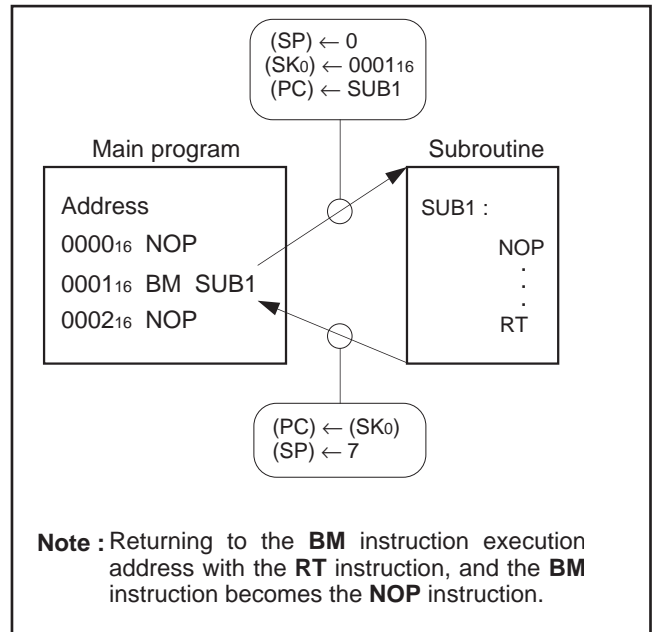

Fig. 6 Example of operation at subroutine call

(8) Program counter (PC)

Program counter (PC) is used to specify a ROM address (page and address). It determines a sequence in which instructions stored in ROM are read. It is a binary counter that increments the number of instruction bytes each time an instruction is executed. However, the value changes to a specified address when branch instructions, subroutine call instructions, return instructions, or the table reference instruction (TABP p) is executed.

Program counter consists of PCH (most significant bit to bit 7) which specifies to a ROM page and PCL (bits 6 to 0) which specifies an address within a page. After it reaches the last address (address 127) of a page, it specifies address 0 of the next page (Figure 7).

Make sure that the PCH does not specify after the last page of the built-in ROM.

(9) Data pointer (DP)

Data pointer (DP) is used to specify a RAM address and consists of registers Z, X, and Y. Register Z specifies a RAM file group, register X specifies a file, and register Y specifies a RAM digit (Figure 8).

Register Y is also used to specify the port D bit position.

When using port D, set the port D bit position to register Y certainly and execute the SD, RD, or SZD instruction (Figure 9).

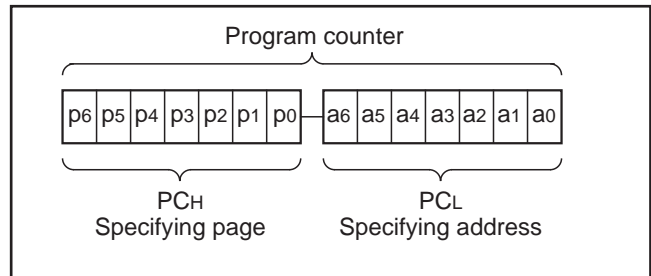

Fig. 7 Program counter (PC) structure

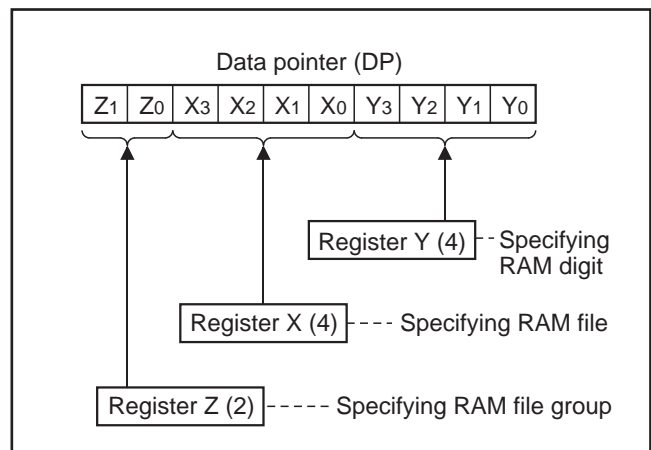

Fig. 8 Data pointer (DP) structure

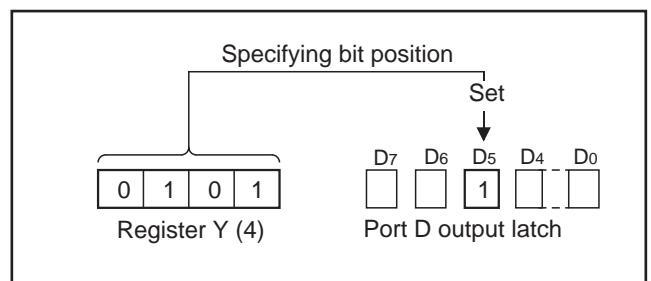

Fig. 9 SD instruction execution example

HARDWARE

FUNCTION BLOCK OPERATIONS

PROGRAM MEMOY (ROM)

The program memory is a mask ROM. 1 word of ROM is composed of 10 bits. ROM is separated every 128 words by the unit of page (addresses 0 to 127). Table 1 shows the ROM size and pages. Figure 10 shows the ROM map of M34514M8/E8.

Table 1 ROM size and pages

Product	ROM size (X 10 bits)	Pages
M34513M2	2048 words	16 (0 to 15)
M34513M4/E4	4096 words	32 (0 to 31)
M34513M6	6144 words	48 (0 to 47)
M34513M8/E8	8192 words	64 (0 to 63)
M34514M6	6144 words	48 (0 to 47)
M34514M8/E8	8192 words	64 (0 to 63)

A part of page 1 (addresses 0080₁₆ to 00FF₁₆) is reserved for interrupt addresses (Figure 11). When an interrupt occurs, the address (interrupt address) corresponding to each interrupt is set in the program counter, and the instruction at the interrupt address is executed. When using an interrupt service routine, write the instruction generating the branch to that routine at an interrupt address.

Page 2 (addresses 0100₁₆ to 017F₁₆) is the special page for subroutine calls. Subroutines written in this page can be called from any page with the 1-word instruction (BM). Subroutines extending from page 2 to another page can also be called with the BM instruction when it starts on page 2.

ROM pattern (bits 7 to 0) of all addresses can be used as data areas with the TABP p instruction.

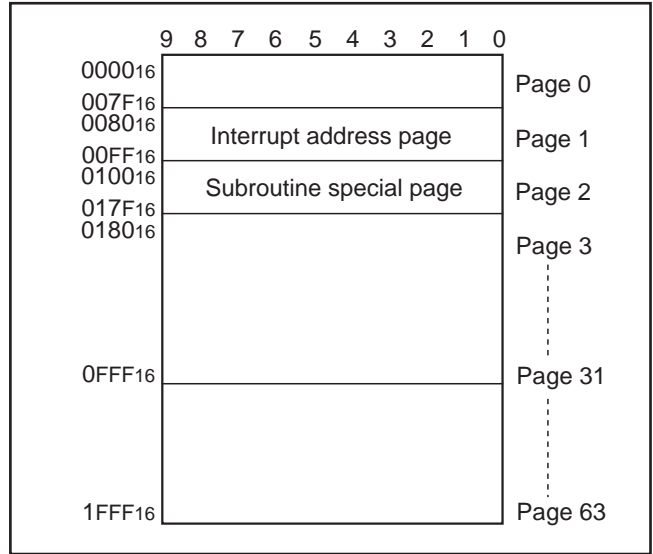

Fig. 10 ROM map of M34514M8/E8

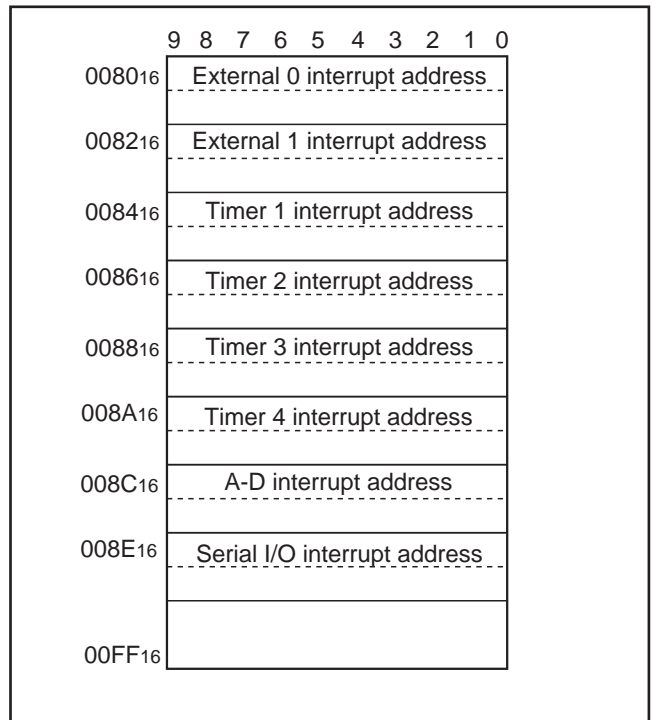

Fig. 11 Page 1 (addresses 0080₁₆ to 00FF₁₆) structure

DATA MEMORY (RAM)

1 word of RAM is composed of 4 bits, but 1-bit manipulation (with the SB j, RB j, and SZB j instructions) is enabled for the entire memory area. A RAM address is specified by a data pointer. The data pointer consists of registers Z, X, and Y. Set a value to the data pointer certainly when executing an instruction to access RAM.

Table 2 shows the RAM size. Figure 12 shows the RAM map.

Table 2 RAM size

Product	RAM size
M34513M2	128 words × 4 bits (512 bits)
M34513M4/E4	256 words × 4 bits (1024 bits)
M34513M6	384 words × 4 bits (1536 bits)
M34513M8/E8	384 words × 4 bits (1536 bits)
M34514M6	384 words × 4 bits (1536 bits)
M34514M8/E8	384 words × 4 bits (1536 bits)

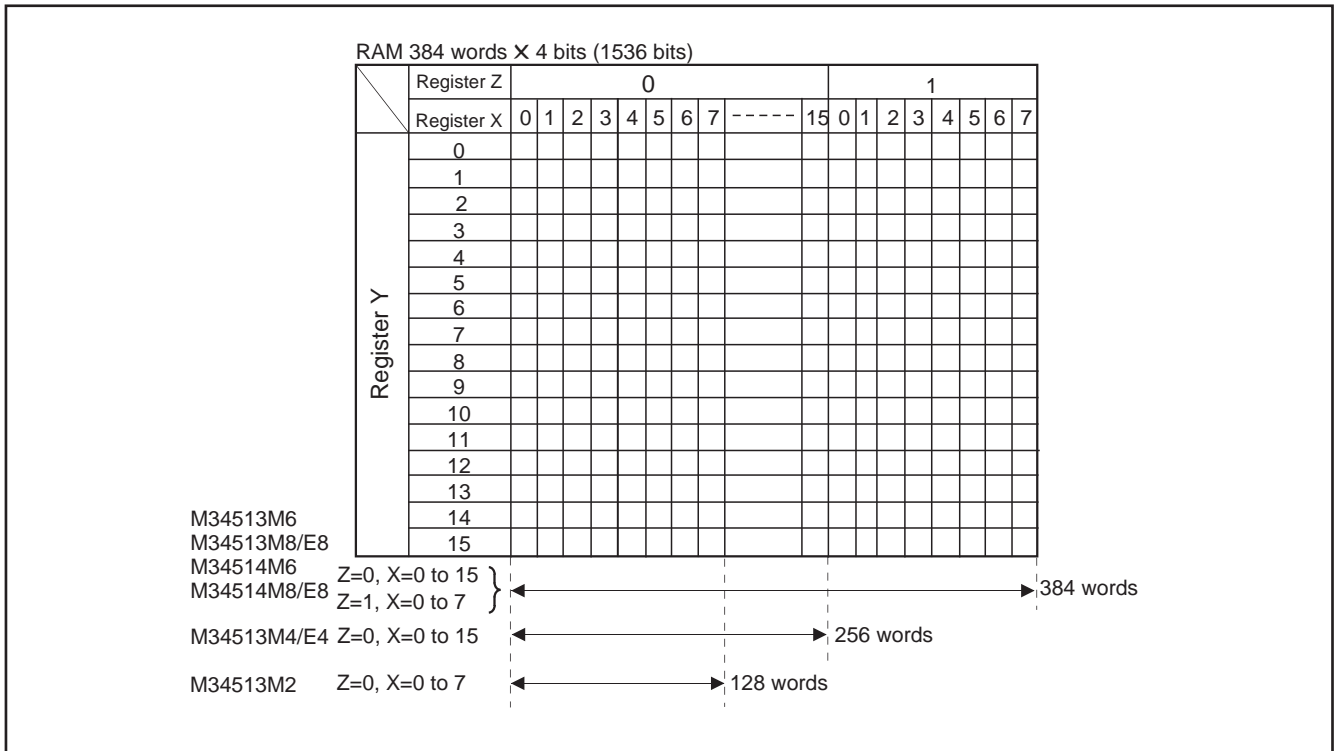

Fig. 12 RAM map

HARDWARE

FUNCTION BLOCK OPERATIONS

INTERRUPT FUNCTION

The interrupt type is a vectored interrupt branching to an individual address (interrupt address) according to each interrupt source. An interrupt occurs when the following 3 conditions are satisfied.

- An interrupt activated condition is satisfied (request flag = "1")
- Interrupt enable bit is enabled ("1")
- Interrupt enable flag is enabled (INTE = "1")

Table 3 shows interrupt sources. (Refer to each interrupt request flag for details of activated conditions.)

(1) Interrupt enable flag (INTE)

The interrupt enable flag (INTE) controls whether the every interrupt enable/disable. Interrupts are enabled when INTE flag is set to "1" with the EI instruction and disabled when INTE flag is cleared to "0" with the DI instruction. When any interrupt occurs, the INTE flag is automatically cleared to "0," so that other interrupts are disabled until the EI instruction is executed.

(2) Interrupt enable bit

Use an interrupt enable bit of interrupt control registers V1 and V2 to select the corresponding interrupt or skip instruction.

Table 4 shows the interrupt request flag, interrupt enable bit and skip instruction.

Table 5 shows the interrupt enable bit function.

(3) Interrupt request flag

When the activated condition for each interrupt is satisfied, the corresponding interrupt request flag is set to "1." Each interrupt request flag is cleared to "0" when either;

- an interrupt occurs, or
- the next instruction is skipped with a skip instruction.

Each interrupt request flag is set when the activated condition is satisfied even if the interrupt is disabled by the INTE flag or its interrupt enable bit. Once set, the interrupt request flag retains set until a clear condition is satisfied.

Accordingly, an interrupt occurs when the interrupt disable state is released while the interrupt request flag is set.

If more than one interrupt request flag is set when the interrupt disable state is released, the interrupt priority level is as follows shown in Table 3.

Table 3 Interrupt sources

Priority level	Interrupt name	Activated condition	Interrupt address
1	External 0 interrupt	Level change of INT0 pin	Address 0 in page 1
2	External 1 interrupt	Level change of INT1 pin	Address 2 in page 1
3	Timer 1 interrupt	Timer 1 underflow	Address 4 in page 1
4	Timer 2 interrupt	Timer 2 underflow	Address 6 in page 1
5	Timer 3 interrupt	Timer 3 underflow	Address 8 in page 1
6	Timer 4 interrupt	Timer 4 underflow	Address A in page 1
7	A-D interrupt	Completion of A-D conversion	Address C in page 1
8	Serial I/O interrupt	Completion of serial I/O transfer	Address E in page 1

Table 4 Interrupt request flag, interrupt enable bit and skip instruction

Interrupt name	Request flag	Skip instruction	Enable bit
External 0 interrupt	EXF0	SNZ0	V10
External 1 interrupt	EXF1	SNZ1	V11
Timer 1 interrupt	T1F	SNZT1	V12
Timer 2 interrupt	T2F	SNZT2	V13
Timer 3 interrupt	T3F	SNZT3	V20
Timer 4 interrupt	T4F	SNZT4	V21
A-D interrupt	ADF	SNZAD	V22
Serial I/O interrupt	SIOF	SNZSI	V23

Table 5 Interrupt enable bit function

Interrupt enable bit	Occurrence of interrupt	Skip instruction
1	Enabled	Invalid
0	Disabled	Valid

(4) Internal state during an interrupt

The internal state of the microcomputer during an interrupt is as follows (Figure 14).

- Program counter (PC)
An interrupt address is set in program counter. The address to be executed when returning to the main routine is automatically stored in the stack register (SK).
- Interrupt enable flag (INTE)
INTE flag is cleared to "0" so that interrupts are disabled.
- Interrupt request flag
Only the request flag for the current interrupt source is cleared to "0."
- Data pointer, carry flag, skip flag, registers A and B
The contents of these registers and flags are stored automatically in the interrupt stack register (SDP).

(5) Interrupt processing

When an interrupt occurs, a program at an interrupt address is executed after branching a data store sequence to stack register. Write the branch instruction to an interrupt service routine at an interrupt address.

Use the RTI instruction to return from an interrupt service routine. Interrupt enabled by executing the EI instruction is performed after executing 1 instruction (just after the next instruction is executed). Accordingly, when the EI instruction is executed just before the RTI instruction, interrupts are enabled after returning the main routine. (Refer to Figure 13)

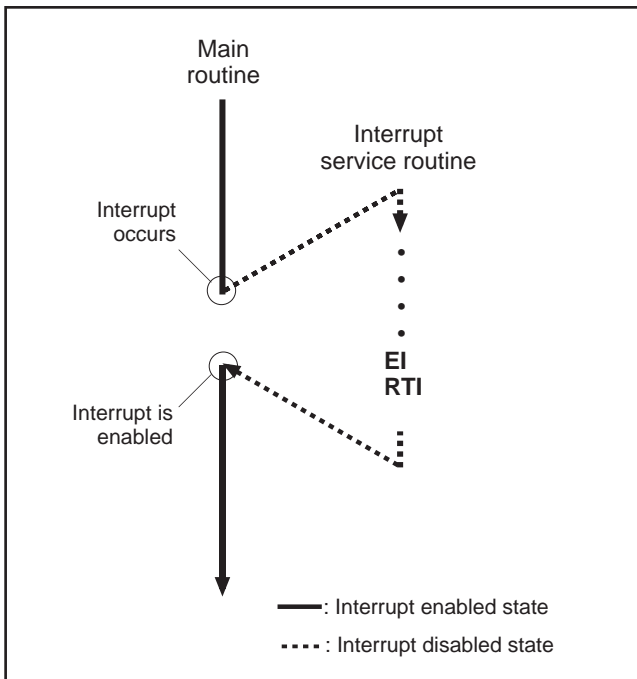

Fig. 13 Program example of interrupt processing

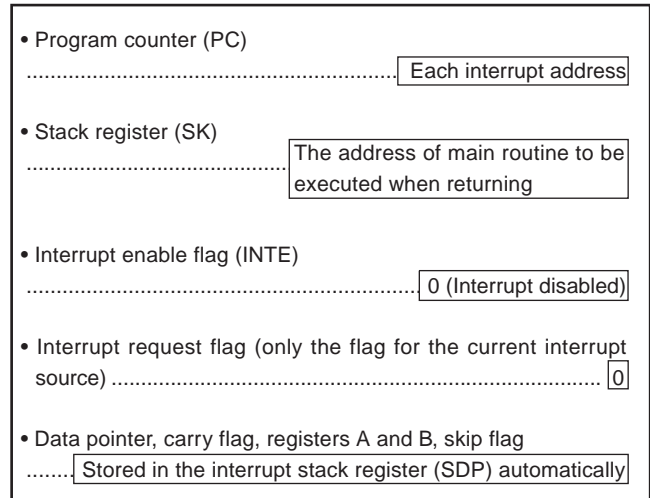

Fig. 14 Internal state when interrupt occurs

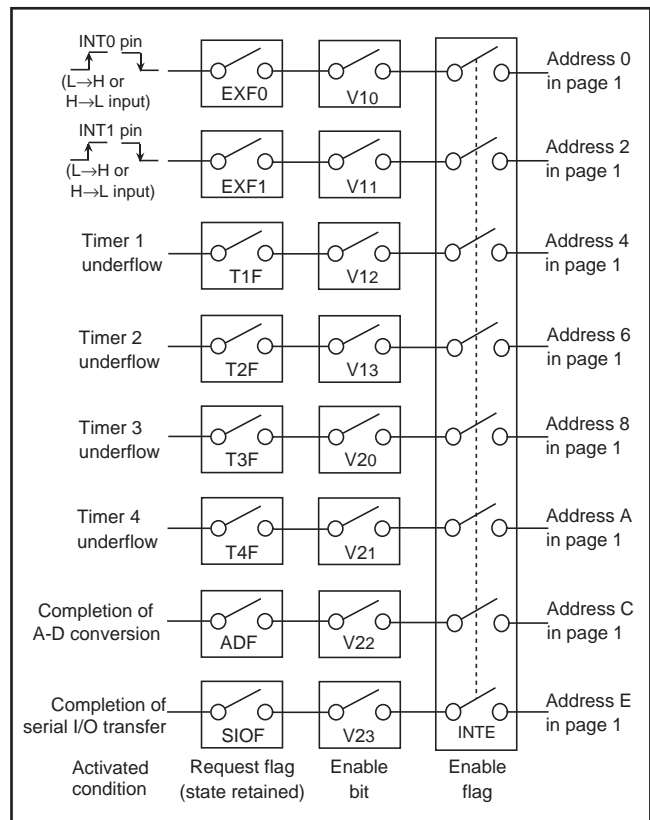

Fig. 15 Interrupt system diagram

HARDWARE

FUNCTION BLOCK OPERATIONS

(6) Interrupt control registers

- Interrupt control register V1

Interrupt enable bits of external 0, external 1, timer 1 and timer 2 are assigned to register V1. Set the contents of this register through register A with the TV1A instruction. The TAV1 instruction can be used to transfer the contents of register V1 to register A.

- Interrupt control register V2

Interrupt enable bits of timer 3, timer 4, A-D and serial I/O are assigned to register V2. Set the contents of this register through register A with the TV2A instruction. The TAV2 instruction can be used to transfer the contents of register V2 to register A.

Table 6 Interrupt control registers

Interrupt control register V1		at reset : 00002		at RAM back-up : 00002		R/W
V13	Timer 2 interrupt enable bit	0	Interrupt disabled (SNZT2 instruction is valid)			
		1	Interrupt enabled (SNZT2 instruction is invalid)			
V12	Timer 1 interrupt enable bit	0	Interrupt disabled (SNZT1 instruction is valid)			
		1	Interrupt enabled (SNZT1 instruction is invalid)			
V11	External 1 interrupt enable bit	0	Interrupt disabled (SNZ1 instruction is valid)			
		1	Interrupt enabled (SNZ1 instruction is invalid)			
V10	External 0 interrupt enable bit	0	Interrupt disabled (SNZ0 instruction is valid)			
		1	Interrupt enabled (SNZ0 instruction is invalid)			
Interrupt control register V2		at reset : 00002		at RAM back-up : 00002		R/W
V23	Serial I/O interrupt enable bit	0	Interrupt disabled (SNZSI instruction is valid)			
		1	Interrupt enabled (SNZSI instruction is invalid)			
V22	A-D interrupt enable bit	0	Interrupt disabled (SNZAD instruction is valid)			
		1	Interrupt enabled (SNZAD instruction is invalid)			
V21	Timer 4 interrupt enable bit	0	Interrupt disabled (SNZT4 instruction is valid)			
		1	Interrupt enabled (SNZT4 instruction is invalid)			
V20	Timer 3 interrupt enable bit	0	Interrupt disabled (SNZT3 instruction is valid)			
		1	Interrupt enabled (SNZT3 instruction is invalid)			

Note: "R" represents read enabled, and "W" represents write enabled.

(7) Interrupt sequence

Interrupts only occur when the respective INTE flag, interrupt enable bits (V10–V13 and V20–V23), and interrupt request flag are “1.” The interrupt actually occurs 2 to 3 machine cycles after the cycle in which all three conditions are satisfied. The interrupt oc-

curs after 3 machine cycles only when the three interrupt conditions are satisfied on execution of other than one-cycle instructions (Refer to Figure 16).

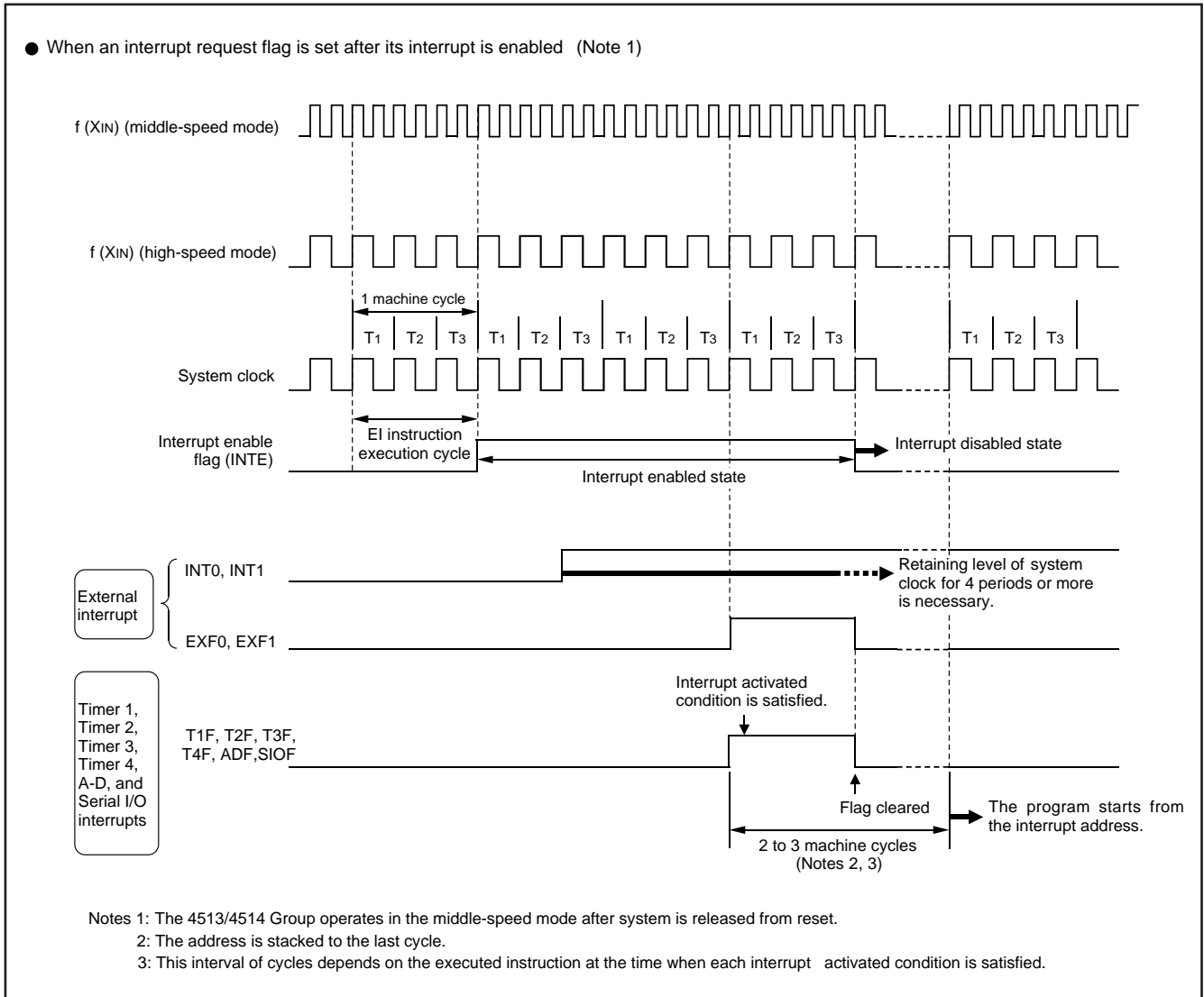

Fig. 16 Interrupt sequence

HARDWARE

FUNCTION BLOCK OPERATIONS

EXTERNAL INTERRUPTS

The 4513/4514 Group has two external interrupts (external 0 and external 1). An external interrupt request occurs when a valid waveform is input to an interrupt input pin (edge detection). The external interrupts can be controlled with the interrupt control registers I1 and I2.

Table 7 External interrupt activated conditions

Name	Input pin	Activated condition	Valid waveform selection bit
External 0 interrupt	P30/INT0	When the next waveform is input to P30/INT0 pin <ul style="list-style-type: none"> • Falling waveform ("H"→"L") • Rising waveform ("L"→"H") • Both rising and falling waveforms 	I11 I12
External 1 interrupt	P31/INT1	When the next waveform is input to P31/INT1 pin <ul style="list-style-type: none"> • Falling waveform ("H"→"L") • Rising waveform ("L"→"H") • Both rising and falling waveforms 	I21 I22

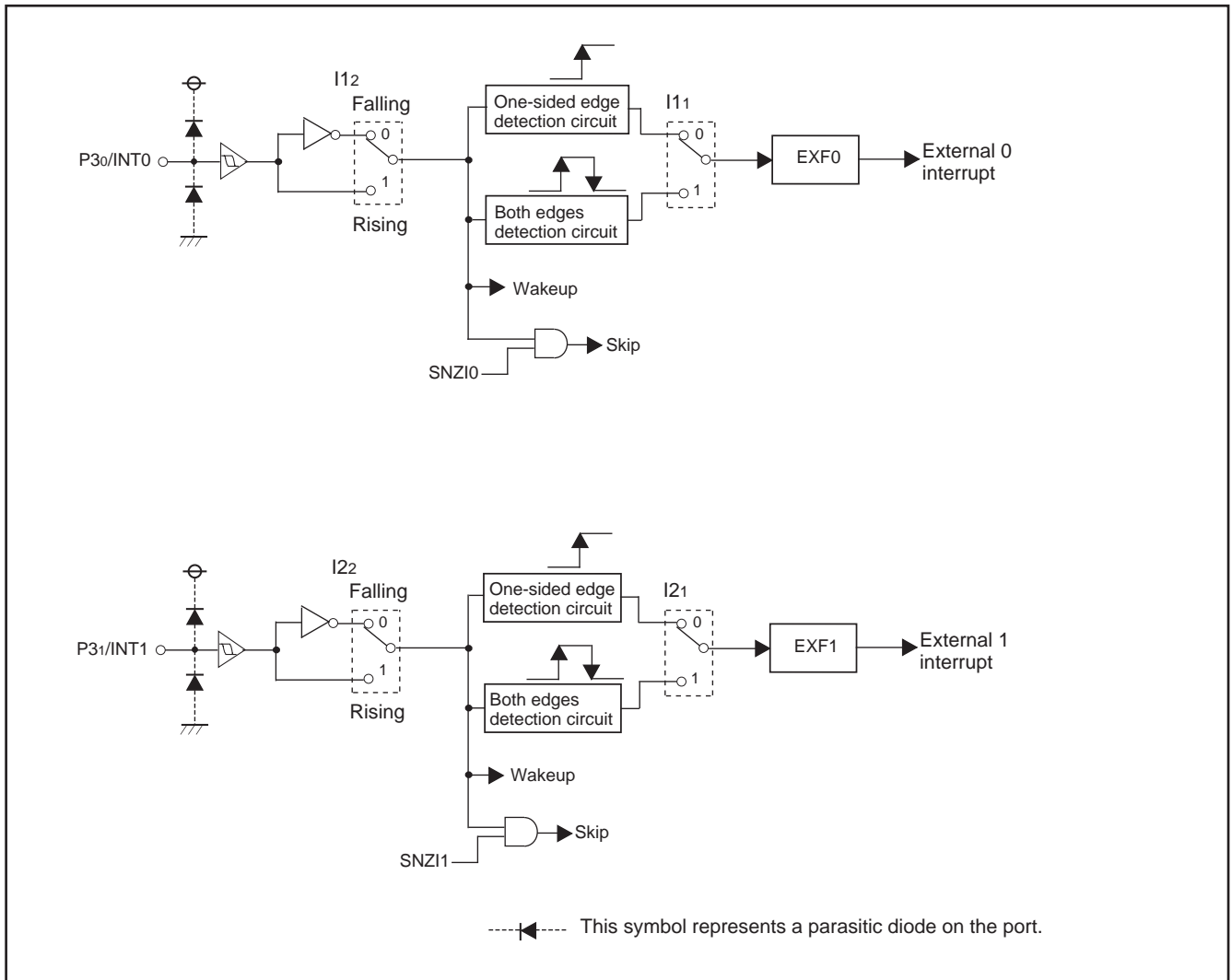

Fig. 17 External interrupt circuit structure

(1) External 0 interrupt request flag (EXF0)

External 0 interrupt request flag (EXF0) is set to "1" when a valid waveform is input to P30/INT0 pin.

The valid waveforms causing the interrupt must be retained at their level for 4 clock cycles or more of the system clock (Refer to Figure 16).

The state of EXF0 flag can be examined with the skip instruction (SNZ0). Use the interrupt control register V1 to select the interrupt or the skip instruction. The EXF0 flag is cleared to "0" when an interrupt occurs or when the next instruction is skipped with the skip instruction.

The P30/INT0 pin need not be selected the external interrupt input INT0 function or the normal I/O port P30 function. However, the EXF0 flag is set to "1" when a valid waveform is input even if it is used as an I/O port P30.

- External 0 interrupt activated condition

External 0 interrupt activated condition is satisfied when a valid waveform is input to P30/INT0 pin.

The valid waveform can be selected from rising waveform, falling waveform or both rising and falling waveforms. An example of how to use the external 0 interrupt is as follows.

- ① Select the valid waveform with the bits 1 and 2 of register I1.
- ② Clear the EXF0 flag to "0" with the SNZ0 instruction.
- ③ Set the NOP instruction for the case when a skip is performed with the SNZ0 instruction.
- ④ Set both the external 0 interrupt enable bit (V10) and the INTE flag to "1."

The external 0 interrupt is now enabled. Now when a valid waveform is input to the P30/INT0 pin, the EXF0 flag is set to "1" and the external 0 interrupt occurs.

(2) External 1 interrupt request flag (EXF1)

External 1 interrupt request flag (EXF1) is set to "1" when a valid waveform is input to P31/INT1 pin.

The valid waveforms causing the interrupt must be retained at their level for 4 clock cycles or more of the system clock (Refer to Figure 16).

The state of EXF1 flag can be examined with the skip instruction (SNZ1). Use the interrupt control register V1 to select the interrupt or the skip instruction. The EXF1 flag is cleared to "0" when an interrupt occurs or when the next instruction is skipped with the skip instruction.

The P31/INT1 pin need not be selected the external interrupt input INT1 function or the normal I/O port P31 function. However, the EXF1 flag is set to "1" when a valid waveform is input even if it is used as an I/O port P31.

- External 1 interrupt activated condition

External 1 interrupt activated condition is satisfied when a valid waveform is input to P31/INT1 pin.

The valid waveform can be selected from rising waveform, falling waveform or both rising and falling waveforms. An example of how to use the external 1 interrupt is as follows.

- ① Select the valid waveform with the bits 1 and 2 of register I2.
- ② Clear the EXF1 flag to "0" with the SNZ1 instruction.
- ③ Set the NOP instruction for the case when a skip is performed with the SNZ1 instruction.
- ④ Set both the external 1 interrupt enable bit (V11) and the INTE flag to "1."

The external 1 interrupt is now enabled. Now when a valid waveform is input to the P31/INT1 pin, the EXF1 flag is set to "1" and the external 1 interrupt occurs.

HARDWARE

FUNCTION BLOCK OPERATIONS

(3) External interrupt control registers

- Interrupt control register I1

Register I1 controls the valid waveform for the external 0 interrupt. Set the contents of this register through register A with the TI1A instruction. The TAI1 instruction can be used to transfer the contents of register I1 to register A.

- Interrupt control register I2

Register I2 controls the valid waveform for the external 1 interrupt. Set the contents of this register through register A with the TI2A instruction. The TAI2 instruction can be used to transfer the contents of register I2 to register A.

Table 8 External interrupt control registers

Interrupt control register I1		at reset : 00002	at RAM back-up : state retained	R/W
I13	Not used	0	This bit has no function, but read/write is enabled.	
		1		
I12	Interrupt valid waveform for INT0 pin/ return level selection bit (Note 2)	0	Falling waveform ("L" level of INT0 pin is recognized with the SNZI0 instruction)/"L" level	
		1	Rising waveform ("H" level of INT0 pin is recognized with the SNZI0 instruction)/"H" level	
I11	INT0 pin edge detection circuit control bit	0	One-sided edge detected	
		1	Both edges detected	
I10	INT0 pin timer 1 control enable bit	0	Disabled	
		1	Enabled	
Interrupt control register I2		at reset : 00002	at RAM back-up : state retained	R/W
I23	Not used	0	This bit has no function, but read/write is enabled.	
		1		
I22	Interrupt valid waveform for INT1 pin/ return level selection bit (Note 3)	0	Falling waveform ("L" level of INT1 pin is recognized with the SNZI1 instruction)/"L" level	
		1	Rising waveform ("H" level of INT1 pin is recognized with the SNZI1 instruction)/"H" level	
I21	INT1 pin edge detection circuit control bit	0	One-sided edge detected	
		1	Both edges detected	
I20	INT1 pin timer 3 control enable bit	0	Disabled	
		1	Enabled	

Notes 1: "R" represents read enabled, and "W" represents write enabled.

2: When the contents of I12 is changed, the external interrupt request flag EXF0 may be set. Accordingly, clear EXF0 flag with the SNZ0 instruction.

3: When the contents of I22 is changed, the external interrupt request flag EXF1 may be set. Accordingly, clear EXF1 flag with the SNZ1 instruction.

TIMERS

The 4513/4514 Group has the programmable timers.

- Programmable timer

The programmable timer has a reload register and enables the frequency dividing ratio to be set. It is decremented from a setting value n . When it underflows (count to $n + 1$), a timer interrupt request flag is set to "1," new data is loaded from the reload register, and count continues (auto-reload function).

- Fixed dividing frequency timer

The fixed dividing frequency timer has the fixed frequency dividing ratio (n). An interrupt request flag is set to "1" after every n count of a count pulse.

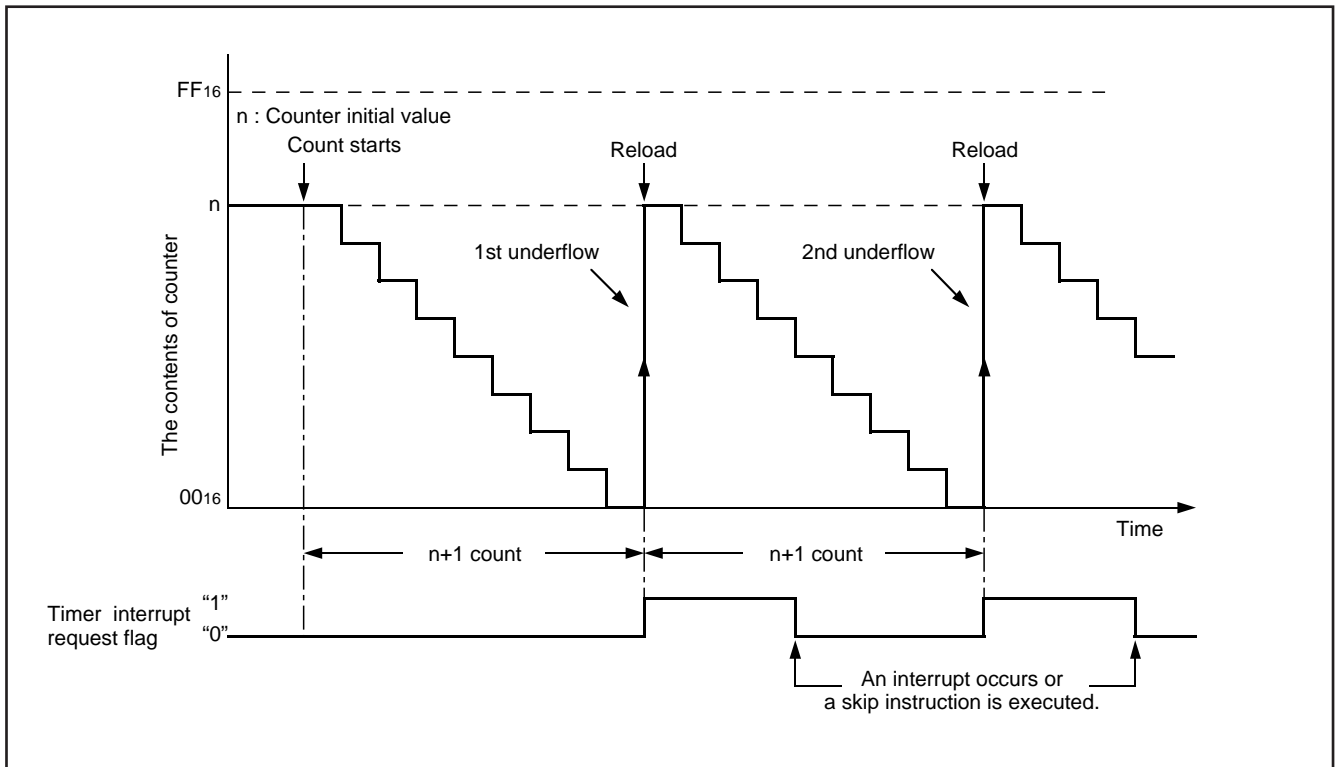

Fig. 18 Auto-reload function

HARDWARE

FUNCTION BLOCK OPERATIONS

The 4513/4514 Group timer consists of the following circuits.

- Prescaler : frequency divider
- Timer 1 : 8-bit programmable timer
- Timer 2 : 8-bit programmable timer
- Timer 3 : 8-bit programmable timer
- Timer 4 : 8-bit programmable timer
(Timers 1 to 4 have the interrupt function, respectively)
- 16-bit timer

Prescaler and timers 1 to 4 can be controlled with the timer control registers W1 to W6. The 16-bit timer is a free counter which is not controlled with the control register.

Each function is described below.

Table 9 Function related timers

Circuit	Structure	Count source	Frequency dividing ratio	Use of output signal	Control register
Prescaler	Frequency divider	• Instruction clock	4, 16	• Timer 1, 2, 3 and 4 count sources	W1
Timer 1	8-bit programmable binary down counter (link to P30/INT0 input)	• Prescaler output (ORCLK)	1 to 256	• Timer 2 count source • CNTR0 output • Timer 1 interrupt	W1 W6
Timer 2	8-bit programmable binary down counter	• Timer 1 underflow • Prescaler output (ORCLK) • CNTR0 input • 16-bit timer underflow	1 to 256	• Timer 3 count source • Timer 2 interrupt • CNTR0 output	W2 W6
Timer 3	8-bit programmable binary down counter (link to P31/INT1 input)	• Timer 2 underflow • Prescaler output (ORCLK)	1 to 256	• Timer 4 count source • Timer 3 interrupt • CNTR1 output	W3 W6
Timer 4	8-bit programmable binary down counter	• Timer 3 underflow • Prescaler output (ORCLK) • CNTR1 input	1 to 256	• Timer 4 interrupt • CNTR1 output	W4 W6
16-bit timer	16-bit fixed dividing frequency	• Instruction clock	65536	• Watchdog timer (The 15th bit is counted twice) • Timer 2 count source (16-bit timer underflow)	

HARDWARE

FUNCTION BLOCK OPERATIONS

Table 10 Timer control registers

Timer control register W1		at reset : 0000z		at RAM back-up : 0000z		R/W
W13	Prescaler control bit	0	Stop (state initialized)			
		1	Operating			
W12	Prescaler dividing ratio selection bit	0	Instruction clock divided by 4			
		1	Instruction clock divided by 16			
W11	Timer 1 control bit	0	Stop (state retained)			
		1	Operating			
W10	Timer 1 count start synchronous circuit control bit	0	Count start synchronous circuit not selected			
		1	Count start synchronous circuit selected			
Timer control register W2		at reset : 0000z		at RAM back-up : state retained		R/W
W23	Timer 2 control bit	0	Stop (state retained)			
		1	Operating			
W22	Not used	0	This bit has no function, but read/write is enabled.			
		1				
W21	Timer 2 count source selection bits	W21	W20	Count source		
		0	0	Timer 1 underflow signal		
W20	Timer 2 count source selection bits	0	1	Prescaler output		
		1	0	CNTR0 input		
		1	1	16 bit timer (WDT) underflow signal		
Timer control register W3		at reset : 0000z		at RAM back-up : state retained		R/W
W33	Timer 3 control bit	0	Stop (state retained)			
		1	Operating			
W32	Timer 3 count start synchronous circuit control bit	0	Count start synchronous circuit not selected			
		1	Count start synchronous circuit selected			
W31	Timer 3 count source selection bits	W31	W30	Count source		
		0	0	Timer 2 underflow signal		
W30	Timer 3 count source selection bits	0	1	Prescaler output		
		1	0	Not available		
		1	1	Not available		
Timer control register W4		at reset : 0000z		at RAM back-up : state retained		R/W
W43	Timer 4 control bit	0	Stop (state retained)			
		1	Operating			
W42	Not used	0	This bit has no function, but read/write is enabled.			
		1				
W41	Timer 4 count source selection bits	W41	W40	Count source		
		0	0	Timer 3 underflow signal		
W40	Timer 4 count source selection bits	0	1	Prescaler output		
		1	0	CNTR1 input		
		1	1	Not available		
Timer control register W6		at reset : 0000z		at RAM back-up : state retained		R/W
W63	CNTR1 output control bit	0	Timer 3 underflow signal output divided by 2			
		1	CNTR1 output control by timer 4 underflow signal divided by 2			
W62	D7/CNTR1 function selection bit	0	D7(I/O)/CNTR1 input			
		1	CNTR1 (I/O)/D7(input)			
W61	CNTR0 output control bit	0	Timer 1 underflow signal output divided by 2			
		1	CNTR0 output control by timer 2 underflow signal divided by 2			
W60	D6/CNTR0 output control bit	0	D6(I/O)/CNTR0 input			
		1	CNTR0 (I/O)/D6(input)			

Note: "R" represents read enabled, and "W" represents write enabled.

(1) Timer control registers

- **Timer control register W1**
Register W1 controls the count operation of timer 1, the selection of count start synchronous circuit, and the frequency dividing ratio and count operation of prescaler. Set the contents of this register through register A with the TW1A instruction. The TAW1 instruction can be used to transfer the contents of register W1 to register A.
- **Timer control register W2**
Register W2 controls the count operation and count source of timer 2. Set the contents of this register through register A with the TW2A instruction. The TAW2 instruction can be used to transfer the contents of register W2 to register A.
- **Timer control register W3**
Register W3 controls the count operation and count source of timer 3 and the selection of count start synchronous circuit. Set the contents of this register through register A with the TW3A instruction. The TAW3 instruction can be used to transfer the contents of register W3 to register A.
- **Timer control register W4**
Register W4 controls the count operation and count source of timer 4. Set the contents of this register through register A with the TW4A instruction. The TAW4 instruction can be used to transfer the contents of register W4 to register A.
- **Timer control register W6**
Register W6 controls the D6/CNTR0 pin and D7/CNTR1 functions, the selection and operation of the CNTR0 and CNTR1 output. Set the contents of this register through register A with the TW6A instruction. The TAW6 instruction can be used to transfer the contents of register W6 to register A.

(2) Precautions

Note the following for the use of timers.

- **Prescaler**
Stop the prescaler operation to change its frequency dividing ratio.
- **Count source**
Stop timer 1, 2, 3, or 4 counting to change its count source.
- **Reading the count value**
Stop timer 1, 2, 3, or 4 counting and then execute the TAB1, TAB2, TAB3, or TAB4 instruction to read its data.
- **Writing to reload registers R1 and R3**
When writing data to reload registers R1 or R3 while timer 1 or timer 3 is operating, avoid a timing when timer 1 or timer 3 underflows.

(3) Prescaler

Prescaler is a frequency divider. Its frequency dividing ratio can be selected. The count source of prescaler is the instruction clock.

Use the bit 2 of register W1 to select the prescaler dividing ratio and the bit 3 to start and stop its operation. Prescaler is initialized, and the output signal (ORCLK) stops when the bit 3 of register W1 is cleared to "0."

(4) Timer 1 (interrupt function)

Timer 1 is an 8-bit binary down counter with the timer 1 reload register (R1). Data can be set simultaneously in timer 1 and the reload register (R1) with the T1AB instruction. Data can be written to reload register (R1) with the TR1AB instruction.

When writing data to reload register R1 with the TR1AB instruction, the downcount after the underflow is started from the setting value of reload register R1.

Timer 1 starts counting after the following process;

- ① set data in timer 1, and
- ② set the bit 1 of register W1 to "1."

However, P30/INT0 pin input can be used as the start trigger for timer 1 count operation by setting the bit 0 of register W1 to "1."

When a value set in timer 1 is n, timer 1 divides the count source signal by n + 1 (n = 0 to 255).

Once count is started, when timer 1 underflows (the next count pulse is input after the contents of timer 1 becomes "0"), the timer 1 interrupt request flag (T1F) is set to "1," new data is loaded from reload register R1, and count continues (auto-reload function).

Data can be read from timer 1 with the TAB1 instruction. When reading the data, stop the counter and then execute the TAB1 instruction. Timer 1 underflow signal divided by 2 can be output from D6/CNTR0 pin.

(5) Timer 2 (interrupt function)

Timer 2 is an 8-bit binary down counter with the timer 2 reload register (R2). Data can be set simultaneously in timer 2 and the reload register (R2) with the T2AB instruction.

Timer 2 starts counting after the following process;

- ① set data in timer 2,
- ② select the count source with the bits 0 and 1 of register W2, and
- ③ set the bit 3 of register W2 to "1."

When a value set in timer 2 is n, timer 2 divides the count source signal by n + 1 (n = 0 to 255).

Once count is started, when timer 2 underflows (the next count pulse is input after the contents of timer 2 becomes "0"), the timer 2 interrupt request flag (T2F) is set to "1," new data is loaded from reload register R2, and count continues (auto-reload function).

Data can be read from timer 2 with the TAB2 instruction. When reading the data, stop the counter and then execute the TAB2 instruction. The output from D6/CNTR0 pin by timer 2 underflow signal divided by 2 can be controlled.

HARDWARE

FUNCTION BLOCK OPERATIONS

(6) Timer 3 (interrupt function)

Timer 3 is an 8-bit binary down counter with the timer 3 reload register (R3). Data can be set simultaneously in timer 3 and the reload register (R3) with the T3AB instruction. Data can be written to reload register (R3) with the TR3AB instruction.

When writing data to reload register R3 with the TR3AB instruction, the downcount after the underflow is started from the setting value of reload register R3.

Timer 3 starts counting after the following process;

- ① set data in timer 3,
- ② select the count source with the bits 0 and 1 of register W3, and
- ③ set the bit 3 of register W3 to "1."

However, P31/INT1 pin input can be used as the start trigger for timer 3 count operation by setting the bit 2 of register W3 to "1."

When a value set in timer 3 is n , timer 3 divides the count source signal by $n + 1$ ($n = 0$ to 255).

Once count is started, when timer 3 underflows (the next count pulse is input after the contents of timer 3 becomes "0"), the timer 3 interrupt request flag (T3F) is set to "1," new data is loaded from reload register R3, and count continues (auto-reload function).

Data can be read from timer 3 with the TAB3 instruction. When reading the data, stop the counter and then execute the TAB3 instruction. Timer 3 underflow signal divided by 2 can be output from D7/CNTR1 pin.

(7) Timer 4 (interrupt function)

Timer 4 is an 8-bit binary down counter with the timer 4 reload register (R4). Data can be set simultaneously in timer 4 and the reload register (R4) with the T4AB instruction.

Timer 4 starts counting after the following process;

- ① set data in timer 4,
- ② select the count source with the bits 0 and 1 of register W4, and
- ③ set the bit 3 of register W4 to "1."

When a value set in timer 4 is n , timer 4 divides the count source signal by $n + 1$ ($n = 0$ to 255).

Once count is started, when timer 4 underflows (the next count pulse is input after the contents of timer 4 becomes "0"), the timer 4 interrupt request flag (T4F) is set to "1," new data is loaded from reload register R4, and count continues (auto-reload function).

Data can be read from timer 4 with the TAB4 instruction. When reading the data, stop the counter and then execute the TAB4 instruction. The output from D7/CNTR1 pin by timer 4 underflow signal divided by 2 can be controlled.

(8) Timer interrupt request flags (T1F, T2F, T3F, and T4F)

Each timer interrupt request flag is set to "1" when each timer underflows. The state of these flags can be examined with the skip instructions (SNZT1, SNZT2, SNZT3, and SNZT4).

Use the interrupt control registers V1, V2 to select an interrupt or a skip instruction.

An interrupt request flag is cleared to "0" when an interrupt occurs or when the next instruction is skipped with a skip instruction.

(9) Timer I/O pin (D6/CNTR0, D7/CNTR1)

D6/CNTR0 pin has functions to input the timer 2 count source, and to output the timer 1 and timer 2 underflow signals divided by 2. D7/CNTR1 pin has functions to input the timer 4 count source, and to output the timer 3 and timer 4 underflow signals divided by 2.

The selection of D6/CNTR0 pin function can be controlled with the bit 0 of register W6. The selection of D7/CNTR1 pin function can be controlled with the bit 2 of register W6.

The following signals can be selected for the CNTR0 output signal with the bit 1 of register W6.

- timer 1 underflow signal divided by 2
- the signal of AND operation between timer 1 underflow signal divided by 2 and timer 2 underflow signal divide by 2

The following signals can be selected for the CNTR1 output signal with the bit 3 of register W6.

- timer 3 underflow signal divided by 2
- the signal of AND operation between timer 3 underflow signal divided by 2 and timer 4 underflow signal divide by 2

Timer 2 counts the rising waveform of CNTR0 input when the CNTR0 input is selected as the count source.

Timer 4 counts the rising waveform of CNTR1 input when the CNTR1 input is selected as the count source.

(10) Count start synchronous circuit (timer 1 and 3)

Each of timer 1 and timer 3 has the count start synchronous circuit which synchronizes P30/INT0 pin and P31/INT1 pin, respectively, and can start the timer count operation.

Timer 1 count start synchronous circuit function is selected by setting the bit 0 of register W1 to "1." The control by P30/INT0 pin input can be performed by setting the bit 0 of register I1 to "1."

The count start synchronous circuit is set by level change ("H"→"L" or "L"→"H") of P30/INT0 pin input. This valid waveform is selected by bits 1 (I11) and 2 (I12) of register I1 as follows;

- I11 = "0": Synchronized with one-sided edge (falling or rising)
- I11 = "1": Synchronized with both edges (both falling and rising)

When register I11="0" (synchronized with the one-sided edge), the rising or falling waveform can be selected by bit 2 of register I1;

- I12 = "0": Falling waveform
- I12 = "1": Rising waveform

Timer 3 count start synchronous circuit function is selected by setting the bit 2 of register W3 to "1." The control by P31/INT1 pin input can be performed by setting the bit 0 of register I2 to "1."

The count start synchronous circuit is set by level change ("H"→"L" or "L"→"H") of P31/INT1 pin input. This valid waveform is selected by bits 1 (I21) and 2 (I22) of register I2 as follows;

- I21 = "0": Synchronized with one-sided edge (falling or rising)
- I21 = "1": Synchronized with both edges (both falling and rising)

When register I21="0" (synchronized with the one-sided edge), the rising or falling waveform can be selected by bit 2 of register I2;

- I22 = "0": Falling waveform
- I22 = "1": Rising waveform

When timer 1 and timer 3 count start synchronous circuits are used, the count start synchronous circuits are set, the count source is input to each timer by inputting valid waveform to P30/INT0 pin and P31/INT1 pin. Once set, the count start synchronous circuit is cleared by clearing the bit I10 or I20 to "0" or reset.

WATCHDOG TIMER

Watchdog timer provides a method to reset the system when a program runs wild. Watchdog timer consists of a 16-bit timer (WDT), watchdog timer enable flag (WEF), and watchdog timer flags (WDF1, WDF2).

The timer WDT downcounts the instruction clocks as the count source. The underflow signal is generated when the count value reaches "0000₁₆." This underflow signal can be used as the timer 2 count source.

When the WRST instruction is executed after system is released from reset, the WEF flag is set to "1". At this time, the watchdog timer starts operating.

When the count value of timer WDT reaches "BFFF₁₆" or "3FFF₁₆," the WDF1 flag is set to "1." If the WRST instruction is never executed while timer WDT counts 32767, WDF2 flag is set to "1," and the RESET pin outputs "L" level to reset the microcomputer. Execute the WRST instruction at each period of 32766 machine cycle or less by software when using watchdog timer to keep the microcomputer operating normally.

To prevent the WDT stopping in the event of misoperation, WEF flag is designed not to initialize once the WRST instruction has been executed. Note also that, if the WRST instruction is never executed, the watchdog timer does not start.

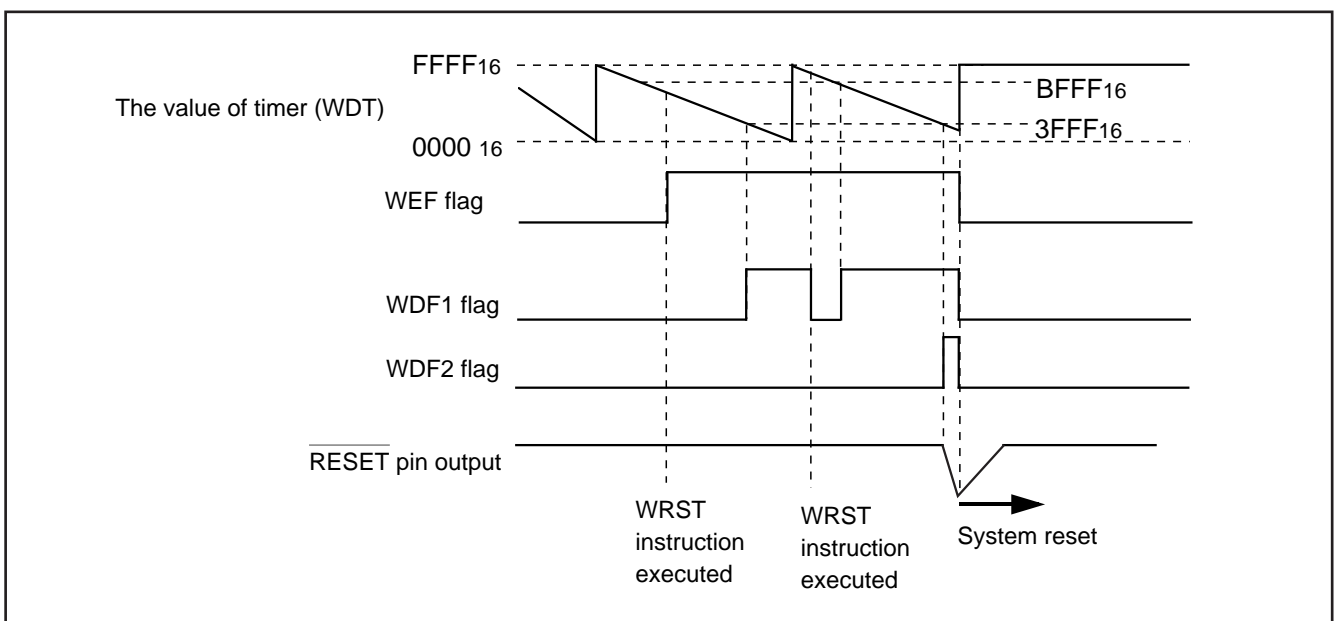

Fig. 20 Watchdog timer function

The contents of WEF, WDF1 and WDF2 flags and timer WDT are initialized at the RAM back-up mode.

If WDF2 flag is set to "1" at the same time that the microcomputer enters the RAM back-up state, system reset may be performed.

When using the watchdog timer and the RAM back-up mode, initialize the WDF1 flag with the WRST instruction just before the microcomputer enters the RAM back-up state (refer to Figure 21)

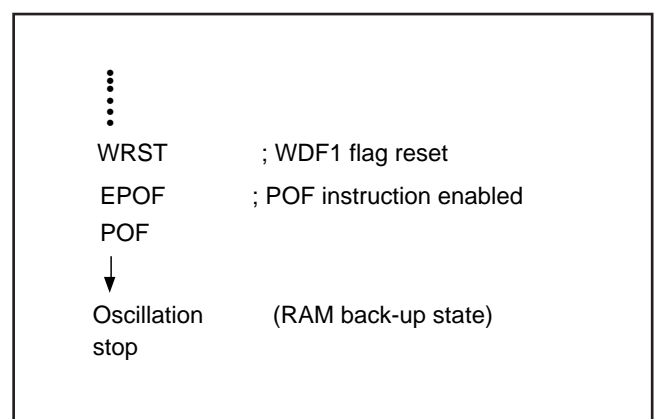

Fig. 21 Program example to enter the RAM back-up mode when using the watchdog timer

HARDWARE

FUNCTION BLOCK OPERATIONS

SERIAL I/O

The 4513/4514 Group has a built-in clock synchronous serial I/O which can serially transmit or receive 8-bit data.

Serial I/O consists of;

- serial I/O register SI
- serial I/O mode register J1
- serial I/O transmission/reception completion flag (SIOF)
- serial I/O counter

Registers A and B are used to perform data transfer with internal CPU, and the serial I/O pins are used for external data transfer.

The pin functions of the serial I/O pins can be set with the register J1.

Table 11 Serial I/O pins

Pin	Pin function when selecting serial I/O
P20/SCK	Clock I/O (SCK)
P21/SOUT	Serial data output (SOUT)
P22/SIN	Serial data input (SIN)

Note: Input ports P20–P22 can be used regardless of register J1.

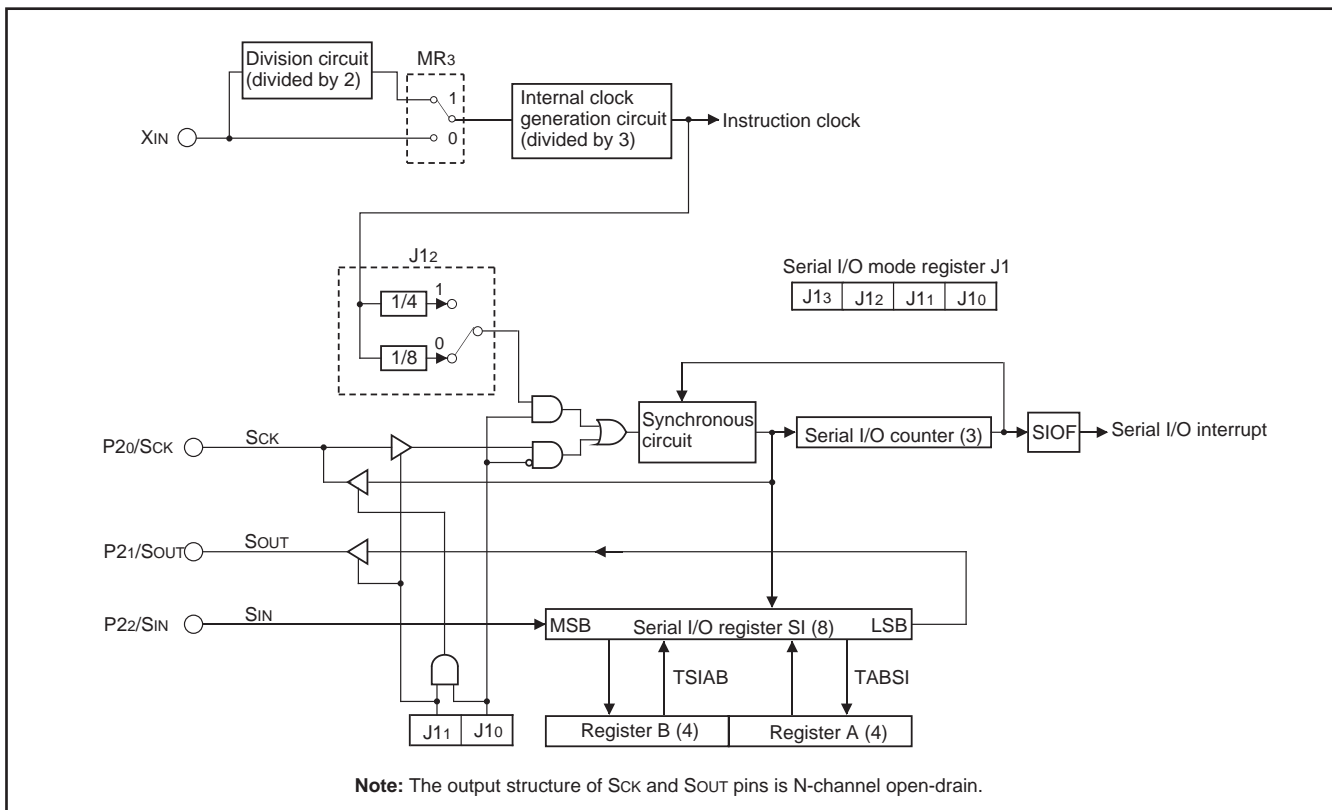

Fig. 22 Serial I/O structure

Table 12 Serial I/O mode register

Serial I/O mode register J1		at reset : 00002	at RAM back-up : state retained	R/W
J13	Not used	0 1	This bit has no function, but read/write is enabled.	
J12	Serial I/O internal clock dividing ratio selection bit	0 1		
J11	Serial I/O port selection bit	0 1	Input ports P20, P21, P22 selected Serial I/O ports SCK, SOUT, SIN/input ports P20, P21, P22 selected	
J10	Serial I/O synchronous clock selection bit	0 1	External clock Internal clock (instruction clock divided by 4 or 8)	

Note: "R" represents read enabled, and "W" represents write enabled.

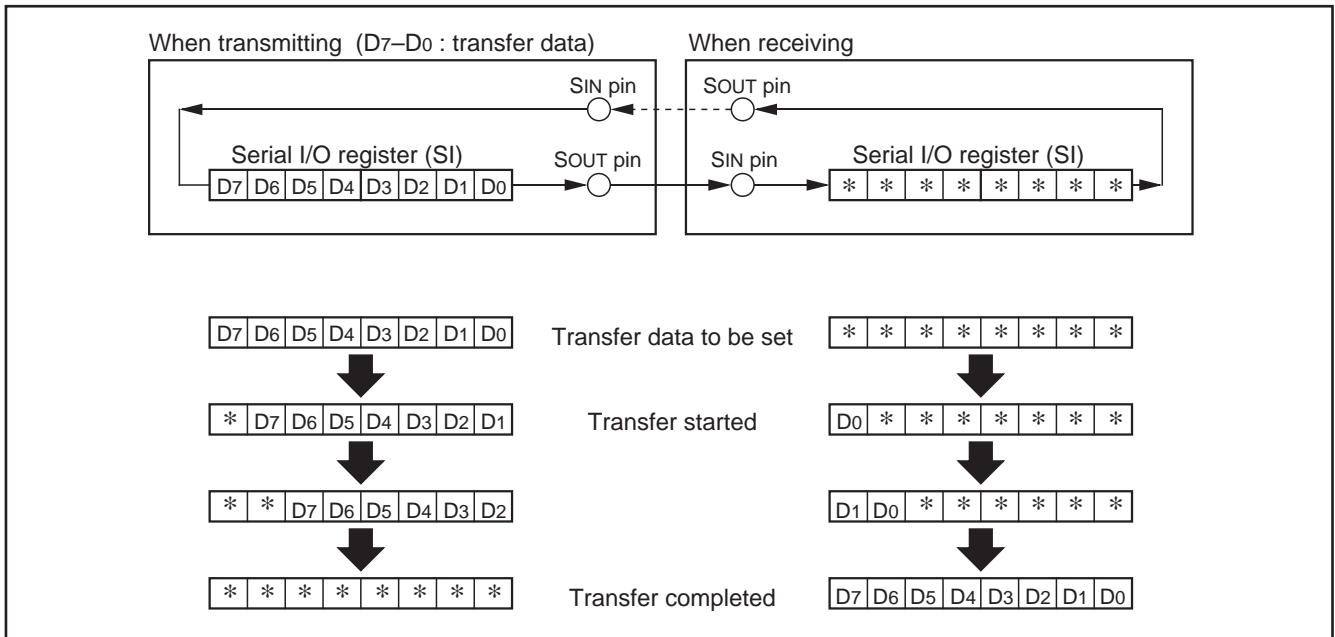

Fig. 23 Serial I/O register state when transferring

(1) Serial I/O register SI

Serial I/O register SI is the 8-bit data transfer serial/parallel conversion register. Data can be set to register SI through registers A and B with the TSIAB instruction. The contents of register A is transmitted to the low-order 4 bits of register SI, and the contents of register B is transmitted to the high-order 4 bits of register SI.

During transmission, each bit data is transmitted LSB first from the lowermost bit (bit 0) of register SI, and during reception, each bit data is received LSB first to register SI starting from the topmost bit (bit 7).

When register SI is used as a work register without using serial I/O, pull up the Sck pin or set the pin function to an input port P20.

(2) Serial I/O transmission/reception completion flag (SIOF)

Serial I/O transmission/reception completion flag (SIOF) is set to "1" when serial data transmission or reception completes. The state of SIOF flag can be examined with the skip instruction (SNZSI). Use the interrupt control register V2 to select the interrupt or the skip instruction.

The SIOF flag is cleared to "0" when the interrupt occurs or when the next instruction is skipped with the skip instruction.

(3) Serial I/O start instruction (SST)

When the SST instruction is executed, the SIOF flag is cleared to "0" and then serial I/O transmission/reception is started.

(4) Serial I/O mode register J1

Register J1 controls the synchronous clock, P20/Sck, P21/Sout and P22/Sin pin function. Set the contents of this register through register A with the TJ1A instruction. The TAJ1 instruction can be used to transfer the contents of register J1 to register A.

HARDWARE

FUNCTION BLOCK OPERATIONS

(5) How to use serial I/O

Figure 24 shows the serial I/O connection example. Serial I/O interrupt is not used in this example. In the actual wiring, pull up the

wiring between each pin with a resistor. Figure 25 shows the data transfer timing and Table 13 shows the data transfer sequence.

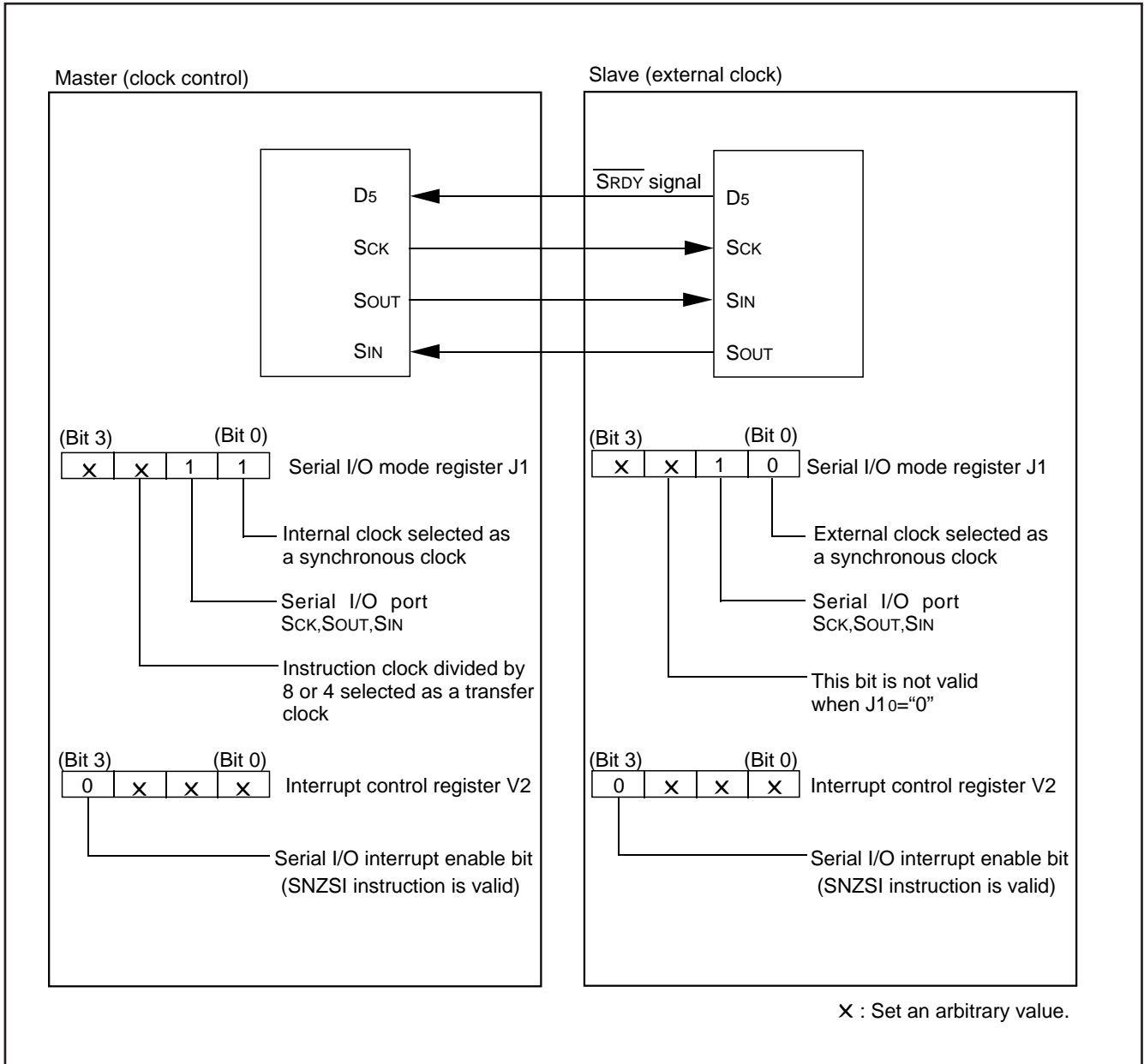

Fig. 24 Serial I/O connection example

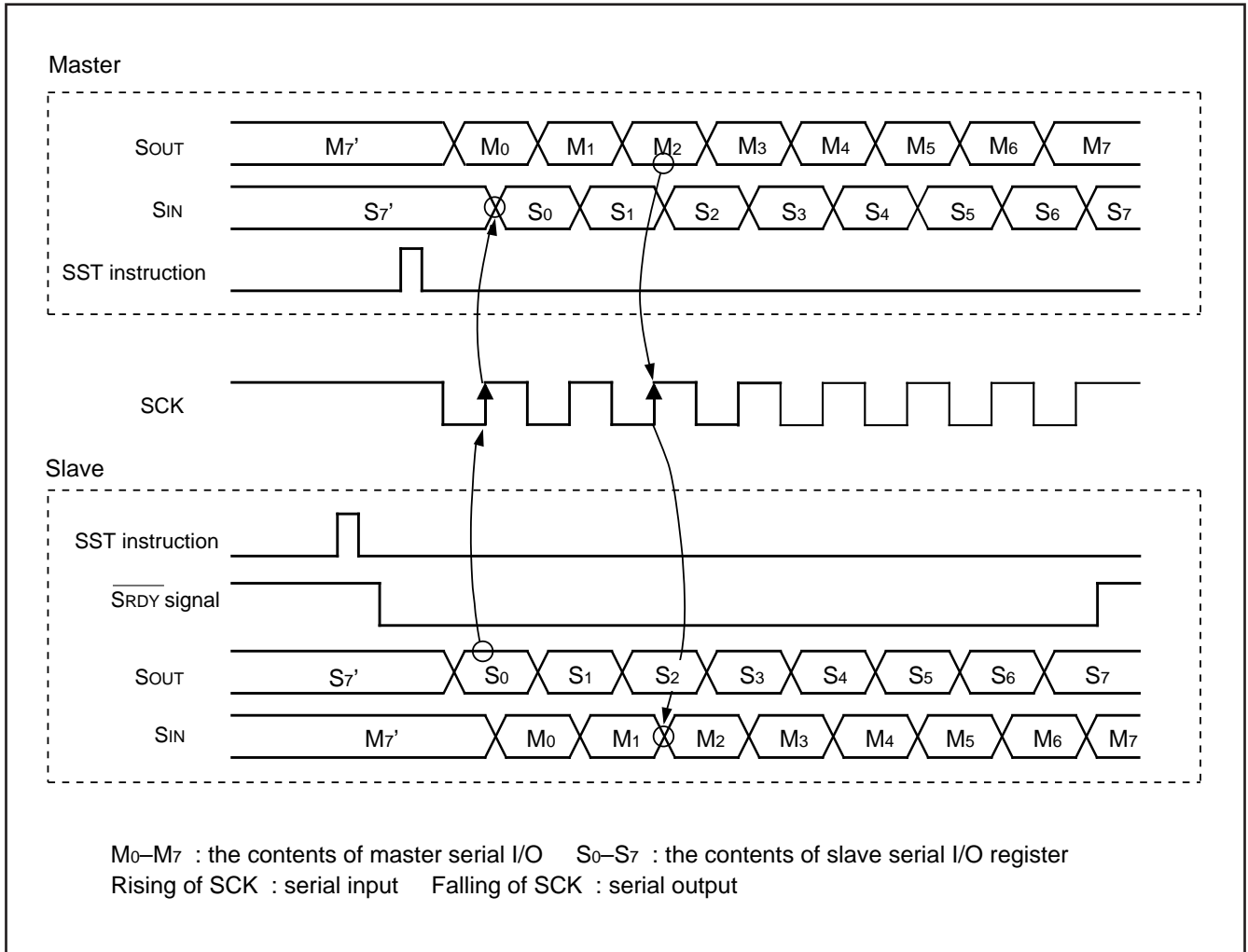

Fig. 25 Timing of serial I/O data transfer

HARDWARE

FUNCTION BLOCK OPERATIONS

Table 13 Processing sequence of data transfer from master to slave

Master (transmission)	Slave (reception)
[Initial setting] • Setting the serial I/O mode register J1 and interrupt control register V2 shown in Figure 24.	[Initial setting] • Setting serial I/O mode register J1, and interrupt control register V2 shown in Figure 24.
TJ1A and TV2A instructions	TJ1A and TV2A instructions
• Setting the port received the reception enable signal (SRDY) to the input mode. (Port D5 is used in this example)	• Setting the port transmitted the reception enable signal (SRDY) and outputting "H" level (reception impossible). (Port D5 is used in this example)
SD instruction	SD instruction
* [Transmission enable state] • Storing transmission data to serial I/O register SI.	* [Reception enable state] • The SIOF flag is cleared to "0."
TSIAB instruction	SST instruction
	• "L" level (reception possible) is output from port D5.
	RD instruction
[Transmission] • Check port D5 is "L" level.	[Reception]
SZD instruction	
• Serial transfer starts.	
SST instruction	
• Check transmission completes.	• Check reception completes.
SNZSI instruction	SNZSI instruction
• Wait (timing when continuously transferring)	• "H" level is output from port D5.
	SD instruction
	[Data processing]

1-byte data is serially transferred on this process. Subsequently, data can be transferred continuously by repeating the process from *.

When an external clock is selected as a synchronous clock, the clock is not controlled internally. Control the clock externally because serial transfer is performed as long as clock is externally input. (Unlike an internal clock, an external clock is not stopped when serial transfer is completed.) However, the SIOF flag is set to "1" when the clock is counted 8 times after executing the SST instruction. Be sure to set the initial level of the external clock to "H."

A-D CONVERTER

The 4513/4514 Group has a built-in A-D conversion circuit that performs conversion by 10-bit successive comparison method. Table 14 shows the characteristics of this A-D converter. This A-D converter can also be used as an 8-bit comparator to compare analog voltages input from the analog input pin with preset values.

Table 14 A-D converter characteristics

Parameter	Characteristics
Conversion format	Successive comparison method
Resolution	10 bits
Relative accuracy	Linearity error: $\pm 2\text{LSB}$
	Non-linearity error: $\pm 0.9\text{LSB}$
Conversion speed	46.5 μs (High-speed mode at 4.0 MHz oscillation frequency)
Analog input pin	4 for 4513 Group
	8 for 4514 Group

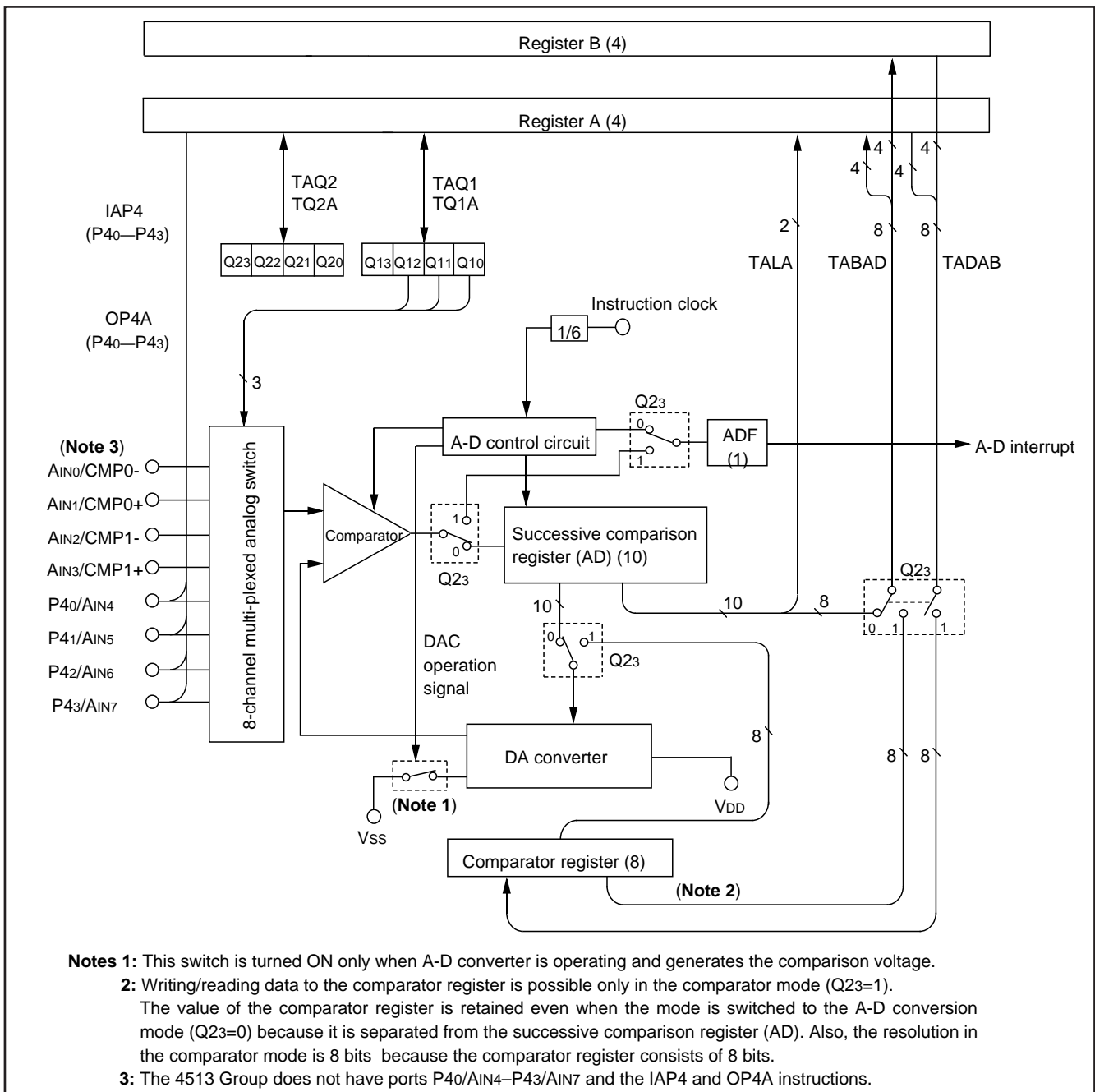

Fig. 26 A-D conversion circuit structure

HARDWARE

FUNCTION BLOCK OPERATIONS

Table 15 A-D control registers

A-D control register Q1		at reset : 00002			at RAM back-up : state retained	R/W
Q13	Not used	0			This bit has no function, but read/write is enabled.	
		1				
Q12	Analog input pin selection bits (Note 2)	Q12	Q11	Q10	Selected pins	
		0	0	0	AIN0	
0		0	1	AIN1		
Q11		0	1	0	AIN2	
		0	1	1	AIN3	
Q10		1	0	0	AIN4 (Not available for the 4513 Group)	
		1	0	1	AIN5 (Not available for the 4513 Group)	
		1	1	0	AIN6 (Not available for the 4513 Group)	
	1	1	1	AIN7 (Not available for the 4513 Group)		
A-D control register Q2		at reset : 00002			at RAM back-up : state retained	R/W
Q23	A-D operation mode selection bit	0			A-D conversion mode	
		1			Comparator mode	
Q22	P43/AIN7 and P42/AIN6 pin function selection bit (Not used for the 4513 Group)	0			P43, P42 (read/write enabled for the 4513 Group)	
		1			AIN7, AIN6/P43, P42 (read/write enabled for the 4513 Group)	
Q21	P41/AIN5 pin function selection bit (Not used for the 4513 Group)	0			P41 (read/write enabled for the 4513 Group)	
		1			AIN5/P41 (read/write enabled for the 4513 Group)	
Q20	P40/AIN4 pin function selection bit (Not used for the 4513 Group)	0			P40 (read/write enabled for the 4513 Group)	
		1			AIN4/P40 (read/write enabled for the 4513 Group)	

Notes 1: "R" represents read enabled, and "W" represents write enabled.

2: Select AIN4–AIN7 with register Q1 after setting register Q2.

(1) Operating at A-D conversion mode

The A-D conversion mode is set by setting the bit 3 of register Q2 to "0."

(2) Successive comparison register AD

Register AD stores the A-D conversion result of an analog input in 10-bit digital data format. The contents of the high-order 8 bits of this register can be stored in register B and register A with the TABAD instruction. The contents of the low-order 2 bits of this register can be stored into the high-order 2 bits of register A with the TALA instruction. However, do not execute this instruction during A-D conversion.

When the contents of register AD is n, the logic value of the comparison voltage V_{ref} generated from the built-in DA converter can be obtained with the reference voltage V_{DD} by the following formula:

Logic value of comparison voltage V_{ref}

$$V_{ref} = \frac{V_{DD}}{1024} \times n$$

n: The value of register AD (n = 0 to 1023)

(3) A-D conversion completion flag (ADF)

A-D conversion completion flag (ADF) is set to "1" when A-D conversion completes. The state of ADF flag can be examined with the skip instruction (SNZAD). Use the interrupt control register V2 to select the interrupt or the skip instruction.

The ADF flag is cleared to "0" when the interrupt occurs or when the next instruction is skipped with the skip instruction.

(4) A-D conversion start instruction (ADST)

A-D conversion starts when the ADST instruction is executed. The conversion result is automatically stored in the register AD.

(5) A-D control register Q1

Register Q1 is used to select one of analog input pins. The 4513 Group does not have AIN4–AIN7. Accordingly, do not select these pins with register Q1.

(6) A-D control register Q2

Register Q2 is used to select the pin function of P40/AIN4, P41/AIN5, P42/AIN6, and P43/AIN7. The A-D conversion mode is selected when the bit 3 of register Q2 is "0," and the comparator mode is selected when the bit 3 of register Q2 is "1." After set this register, select the analog input with register Q1.

Even when register Q2 is used to set the pins for analog input, P40/AIN4–P43/AIN7 continue to function as P40–P43 I/O. Accordingly, when any of them are used as I/O port P4 and others are used as analog input pins, make sure to set the outputs of pins that are set for analog input to "1." Also, for the port input, the port input function of the pin functions as analog input is undefined.

(7) Operation description

A-D conversion is started with the A-D conversion start instruction (ADST). The internal operation during A-D conversion is as follows:

- ① When A-D conversion starts, the register AD is cleared to "000₁₆."
- ② Next, the topmost bit of the register AD is set to "1," and the comparison voltage V_{ref} is compared with the analog input voltage V_{IN} .
- ③ When the comparison result is $V_{ref} < V_{IN}$, the topmost bit of the register AD remains set to "1." When the comparison result is $V_{ref} > V_{IN}$, it is cleared to "0."

The 4513/4514 Group repeats this operation to the lowermost bit of the register AD to convert an analog value to a digital value. A-D conversion stops after 62 machine cycles (46.5 μ s when $f(X_{IN}) = 4.0$ MHz in high-speed mode) from the start, and the conversion result is stored in the register AD. An A-D interrupt activated condition is satisfied and the ADF flag is set to "1" as soon as A-D conversion completes (Figure 27).

Table 16 Change of successive comparison register AD during A-D conversion

At starting conversion	Change of successive comparison register AD							Comparison voltage (V_{ref}) value		
1st comparison	1	0	0	----	0	0	0	$\frac{V_{DD}}{2}$		
2nd comparison	*1	1	0	----	0	0	0	$\frac{V_{DD}}{2} \pm \frac{V_{DD}}{4}$		
3rd comparison	*1	*2	1	----	0	0	0	$\frac{V_{DD}}{2} \pm \frac{V_{DD}}{4} \pm \frac{V_{DD}}{8}$		
After 10th comparison completes	A-D conversion result							$\frac{V_{DD}}{2} \pm \dots \pm \frac{V_{DD}}{1024}$		
	*1	*2	*3	----	*8	*9	*A			

*1: 1st comparison result
 *3: 3rd comparison result
 *9: 9th comparison result

*2: 2nd comparison result
 *8: 8th comparison result
 *A: 10th comparison result

HARDWARE

FUNCTION BLOCK OPERATIONS

(8) A-D conversion timing chart

Figure 27 shows the A-D conversion timing chart.

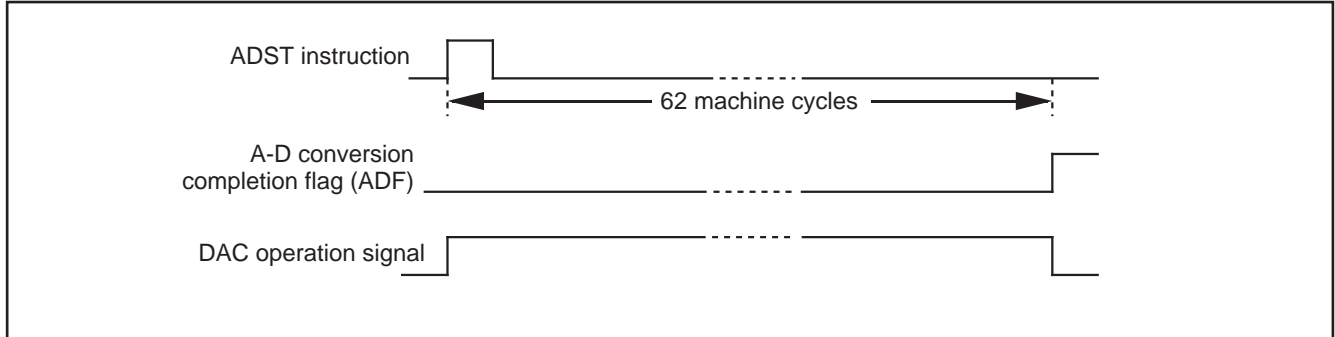

Fig. 27 A-D conversion timing chart

(9) How to use A-D conversion

How to use A-D conversion is explained using as example in which the analog input from P40/AIN4 pin is A-D converted, and the high-order 4 bits of the converted data are stored in address $M(Z, X, Y) = (0, 0, 0)$, the middle-order 4 bits in address $M(Z, X, Y) = (0, 0, 1)$, and the low-order 2 bits in address $M(Z, X, Y) = (0, 0, 2)$ of RAM. The A-D interrupt is not used in this example.

- ① After selecting the AIN4 pin function with the bit 0 of the register Q2, select AIN4 pin and A-D conversion mode with the register Q1 (refer to Figure 28).
- ② Execute the ADST instruction and start A-D conversion.
- ③ Examine the state of ADF flag with the SNZAD instruction to determine the end of A-D conversion.
- ④ Transfer the low-order 2 bits of converted data to the high-order 2 bits of register A (TALA instruction).
- ⑤ Transfer the contents of register A to $M(Z, X, Y) = (0, 0, 2)$.
- ⑥ Transfer the high-order 8 bits of converted data to registers A and B (TABAD instruction).
- ⑦ Transfer the contents of register A to $M(Z, X, Y) = (0, 0, 1)$.
- ⑧ Transfer the contents of register B to register A, and then, store into $M(Z, X, Y) = (0, 0, 0)$.

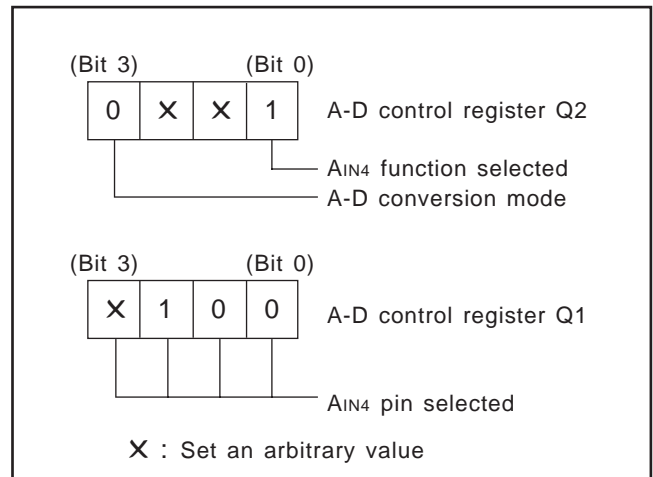

Fig. 28 Setting registers

(10) Operation at comparator mode

The A-D converter is set to comparator mode by setting bit 3 of the register Q2 to "1."

Below, the operation at comparator mode is described.

(11) Comparator register

In comparator mode, the built-in DA comparator is connected to the comparator register as a register for setting comparison voltages. The contents of register B is stored in the high-order 4 bits of the comparator register and the contents of register A is stored in the low-order 4 bits of the comparator register with the TADAB instruction.

When changing from A-D conversion mode to comparator mode, the result of A-D conversion (register AD) is undefined.

However, because the comparator register is separated from register AD, the value is retained even when changing from comparator mode to A-D conversion mode. Note that the comparator register can be written and read at only comparator mode.

If the value in the comparator register is n , the logic value of comparison voltage V_{ref} generated by the built-in DA converter can be determined from the following formula:

Logic value of comparison voltage V_{ref}

$$V_{ref} = \frac{V_{DD}}{256} \times n$$

n : The value of register AD ($n = 0$ to 255)

(12) Comparison result store flag (ADF)

In comparator mode, the ADF flag, which shows completion of A-D conversion, stores the results of comparing the analog input voltage with the comparison voltage. When the analog input voltage is lower than the comparison voltage, the ADF flag is set to "1." The state of ADF flag can be examined with the skip instruction (SNZAD). Use the interrupt control register V2 to select the interrupt or the skip instruction.

The ADF flag is cleared to "0" when the interrupt occurs or when the next instruction is skipped with the skip instruction.

(13) Comparator operation start instruction (ADST instruction)

In comparator mode, executing ADST starts the comparator operating.

The comparator stops 8 machine cycles after it has started ($6 \mu s$ at $f(X_{IN}) = 4.0 \text{ MHz}$ in high-speed mode). When the analog input voltage is lower than the comparison voltage, the ADF flag is set to "1."

(14) Notes for the use of A-D conversion 1

Note the following when using the analog input pins also for I/O port P4 functions:

- Even when P40/AIN4–P43/AIN7 are set to pins for analog input, they continue to function as P40–P43 I/O. Accordingly, when any of them are used as I/O port P4 and others are used as analog input pins, make sure to set the outputs of pins that are set for analog input to "1." Also, the port input function of the pin functions as an analog input is undefined.
- TALA instruction
When the TALA instruction is executed, the low-order 2 bits of register AD is transferred to the high-order 2 bits of register A, simultaneously, the low-order 2 bits of register A is "0."

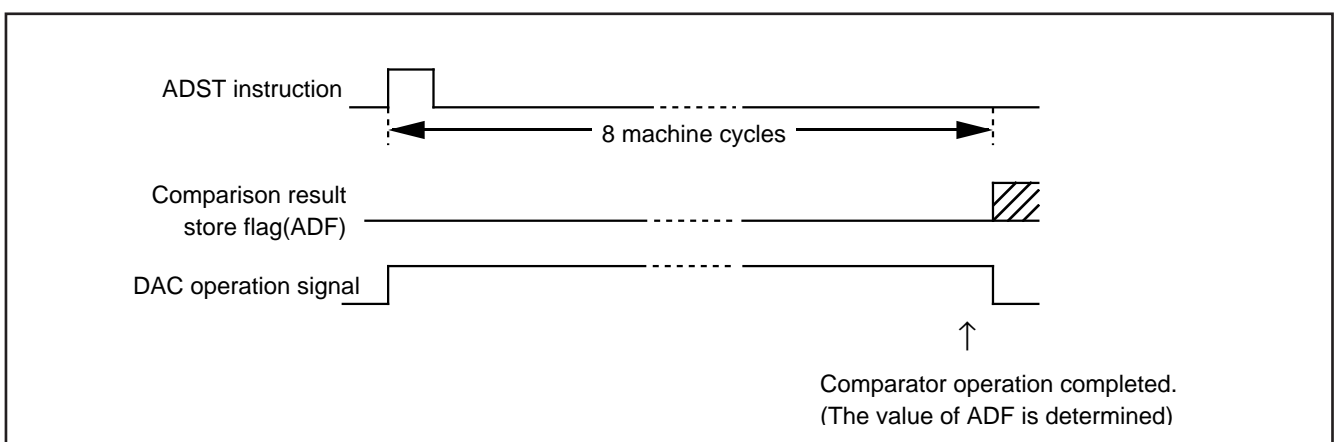

Fig. 29 Comparator operation timing chart

HARDWARE

FUNCTION BLOCK OPERATIONS

(15) Notes for the use of A-D conversion 2

Do not change the operating mode (both A-D conversion mode and comparator mode) of A-D converter with bit 3 of register Q2 while A-D converter is operating.

When the operating mode of A-D converter is changed from the comparator mode to A-D conversion mode with the bit 3 of register Q2, note the following;

- Clear bit 2 of register V2 to "0" to change the operating mode of the A-D converter from the comparator mode to A-D conversion mode with the bit 3 of register Q2.
- The A-D conversion completion flag (ADF) may be set when the operating mode of the A-D converter is changed from the comparator mode to the A-D conversion mode. Accordingly, set a value to register Q2, and execute the SNZAD instruction to clear the ADF flag.

(16) Definition of A-D converter accuracy

The A-D conversion accuracy is defined below (refer to Figure 30).

- Relative accuracy
 - ① Zero transition voltage (V_{0T})
This means an analog input voltage when the actual A-D conversion output data changes from "0" to "1."
 - ② Full-scale transition voltage (VFST)
This means an analog input voltage when the actual A-D conversion output data changes from "1023" to "1022."
 - ③ Linearity error
This means a deviation from the line between V_{0T} and VFST of a converted value between V_{0T} and VFST.
 - ④ Differential non-linearity error
This means a deviation from the input potential difference required to change a converter value between V_{0T} and VFST by 1 LSB at the relative accuracy.
- Absolute accuracy
This means a deviation from the ideal characteristics between 0 to V_{DD} of actual A-D conversion characteristics.

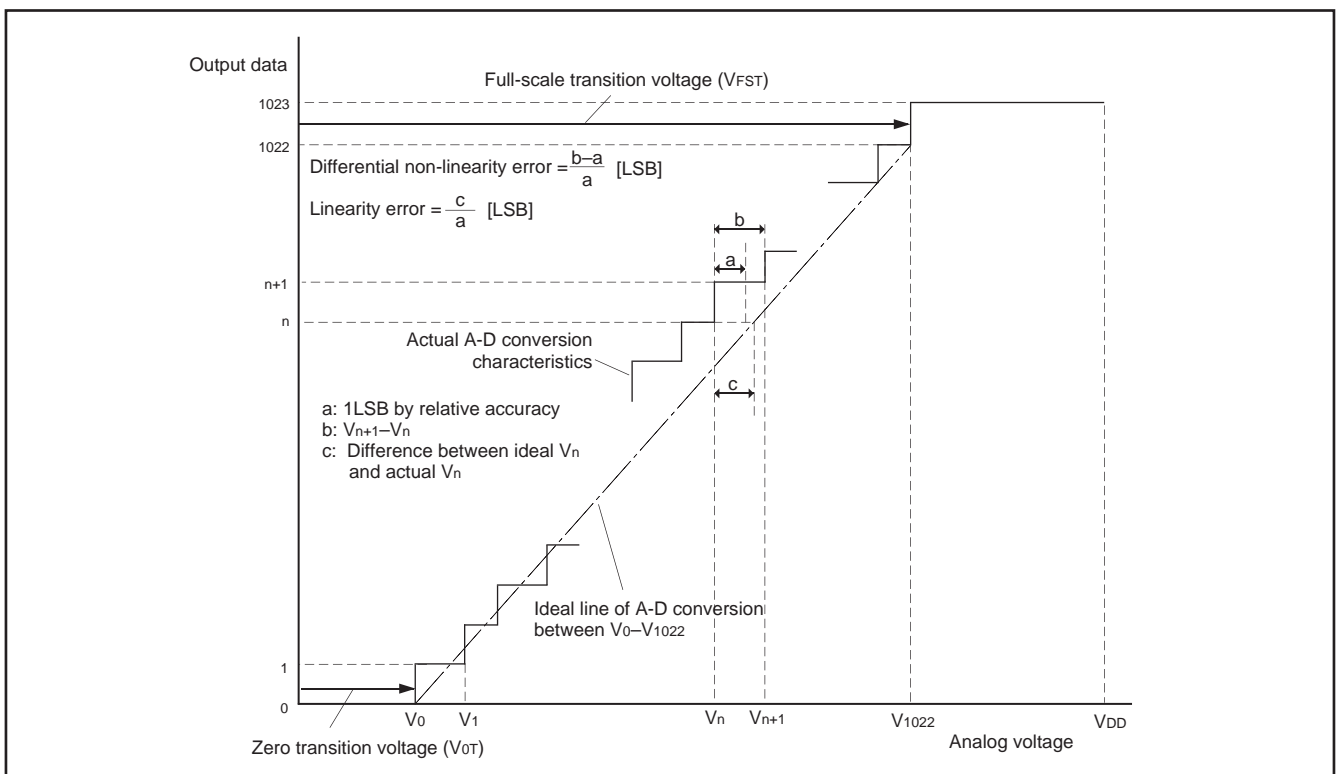

Fig. 30 Definition of A-D conversion accuracy

V_n : Analog input voltage when the output data changes from "n" to "n+1" (n = 0 to 1022)

- 1LSB at relative accuracy $\rightarrow \frac{VFST - V_{0T}}{1022}$ (V)
- 1LSB at absolute accuracy $\rightarrow \frac{V_{DD}}{1024}$ (V)

VOLTAGE COMPARATOR

The 4513/4514 Group has 2 voltage comparator circuits that perform comparison of voltage between 2 pins. Table 17 shows the characteristics of this voltage comparison.

Table 17 Voltage comparator characteristics

Parameter	Characteristics
Voltage comparator function	2 circuits (CMP0, CMP1)
Input pin	CMP0-, CMP0+ (also used as AIN0, AIN1) CMP1-, CMP1+ (also used as AIN2, AIN3)
Supply voltage	3.0 V to 5.5 V
Input voltage	0.3 V _{DD} to 0.7 V _{DD}
Comparison check error	Typ. 20 mV, Max. 100 mV
Response time	Max. 20 μs

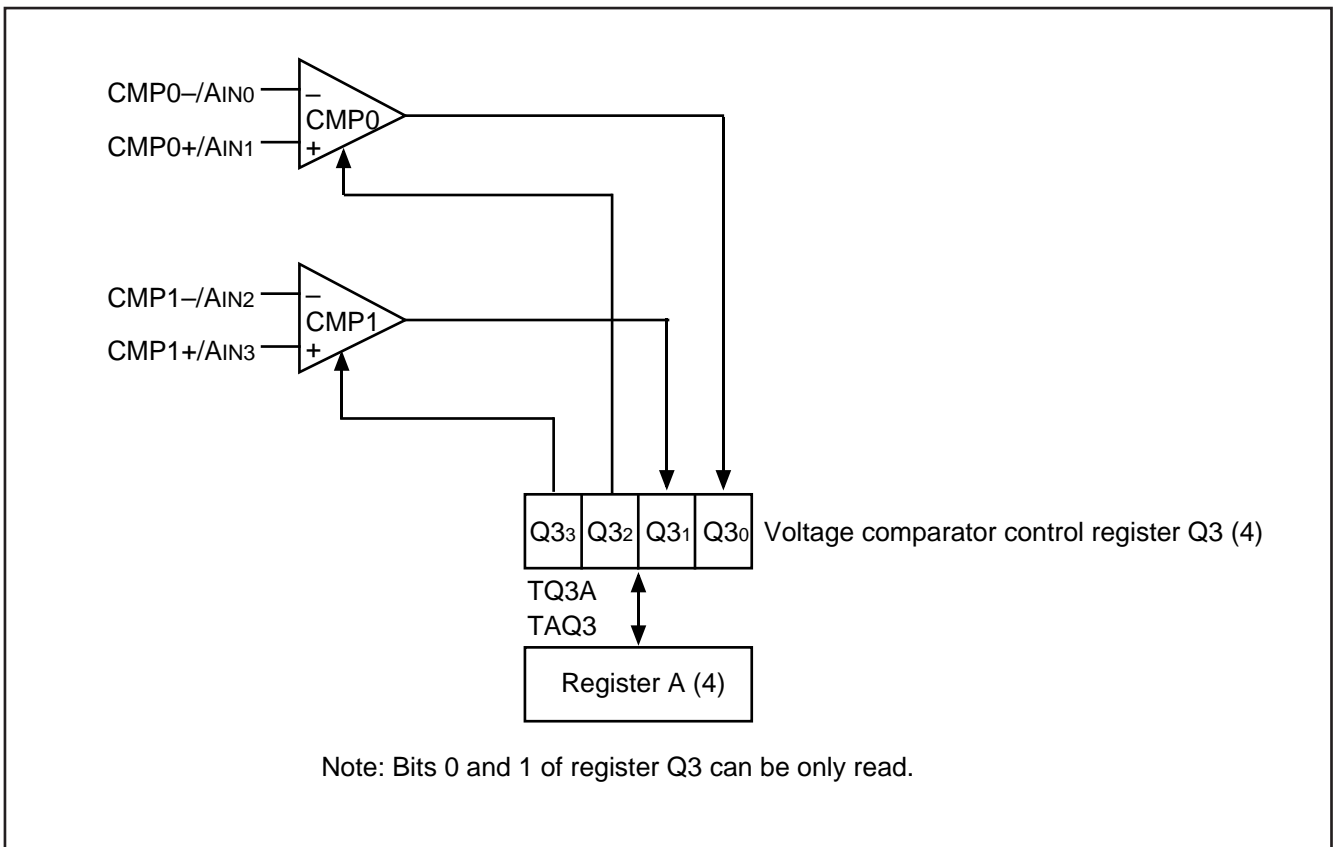

Fig. 31 Voltage comparator structure

HARDWARE

FUNCTION BLOCK OPERATIONS

Table 18 Voltage comparator control register Q3

Voltage comparator control register Q3 (Note 2)		at reset : 00002		at RAM back-up : state retained	R/W
Q33	Voltage comparator (CMP1) control bit	0	Voltage comparator (CMP1) invalid		
		1	Voltage comparator (CMP1) valid		
Q32	Voltage comparator (CMP0) control bit	0	Voltage comparator (CMP0) invalid		
		1	Voltage comparator (CMP0) valid		
Q31	CMP1 comparison result store bit	0	CMP1- > CMP1+		
		1	CMP1- < CMP1+		
Q30	CMP0 comparison result store bit	0	CMP0- > CMP0+		
		1	CMP0- < CMP0+		

Notes 1: "R" represents read enabled, and "W" represents write enabled.
2: Bits 0 and 1 of register Q3 can be only read.

(1) Voltage comparator control register Q3

Register Q3 controls the function of the voltage comparator.

The function of the voltage comparator CMP0 becomes valid by setting bit 2 of register Q3 to "1," and becomes invalid by setting bit 2 of register Q3 to "0." The comparison result of the voltage comparator CMP0 is stored into bit 0 of register Q3.

The function of the voltage comparator CMP1 becomes valid by setting bit 3 of register Q3 to "1," and becomes invalid by setting bit 3 of register Q3 to "0." The comparison result of the voltage comparator CMP1 is stored into bit 1 of register Q3.

(2) Operation description of voltage comparator

The voltage comparator function becomes valid by setting each control bit of register Q3 to "1" and compares the voltage of the input pin. The comparison result is stored into each comparison result store bit of register Q3.

The comparison result is as follows;

- When CMP0- > CMP0+, Q30 = "0"
When CMP0- < CMP0+, Q30 = "1"
- When CMP1- > CMP1+, Q31 = "0"
When CMP1- < CMP1+, Q31 = "1"

(3) Precautions

When the voltage comparator is used, note the following;

- Voltage comparator function
When the voltage comparator function is valid with the voltage comparator control register Q3, it is operating even in the RAM back-up mode. Accordingly, be careful about such state because it causes the increase of the operation current in the RAM back-up mode.
In order to reduce the operation current in the RAM back-up mode, invalidate (bits 2 and 3 of register Q3 = "0") the voltage comparator function by software before the POF instruction is executed.
Also, while the voltage comparator function is valid, current is always consumed by voltage comparator. On the system required for the low-power dissipation, invalidate the voltage comparator by software when it is unused.
- Register Q3
Bits 0 and 1 of register Q3 can be only read. Note that they cannot be written.
- Reading the comparison result of voltage comparator
Read the voltage comparator comparison result from register Q3 after the voltage comparator response time (max. 20 μ s) is passed from the voltage comparator function becomes valid.

RESET FUNCTION

System reset is performed by applying "L" level to $\overline{\text{RESET}}$ pin for 1 machine cycle or more when the following condition is satisfied; the value of supply voltage is the minimum value or more of the recommended operating conditions.

Then when "H" level is applied to $\overline{\text{RESET}}$ pin, software starts from address 0 in page 0.

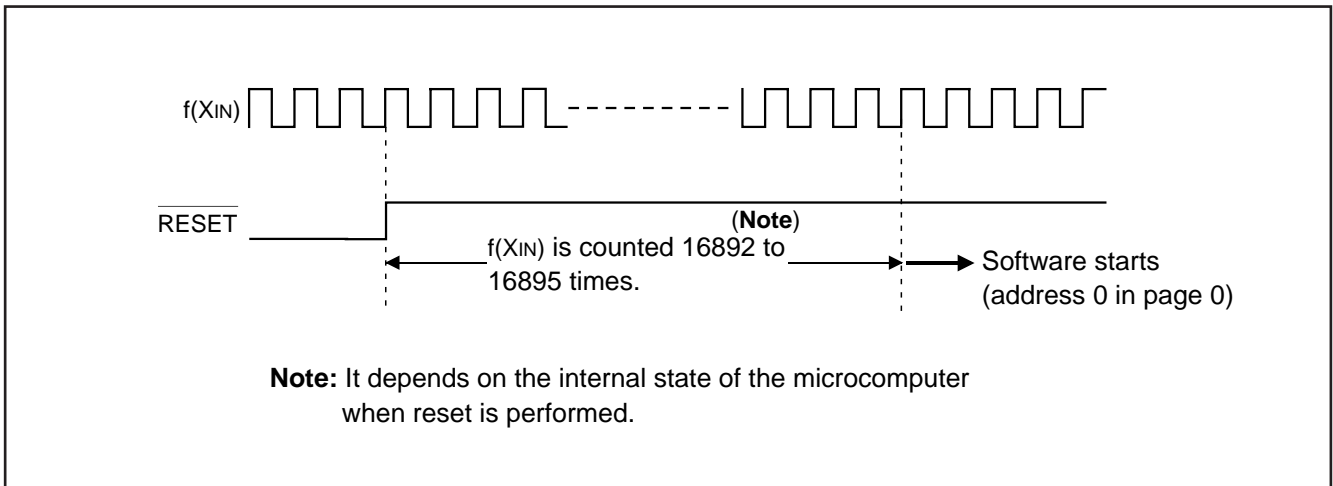

Fig. 32 Reset release timing

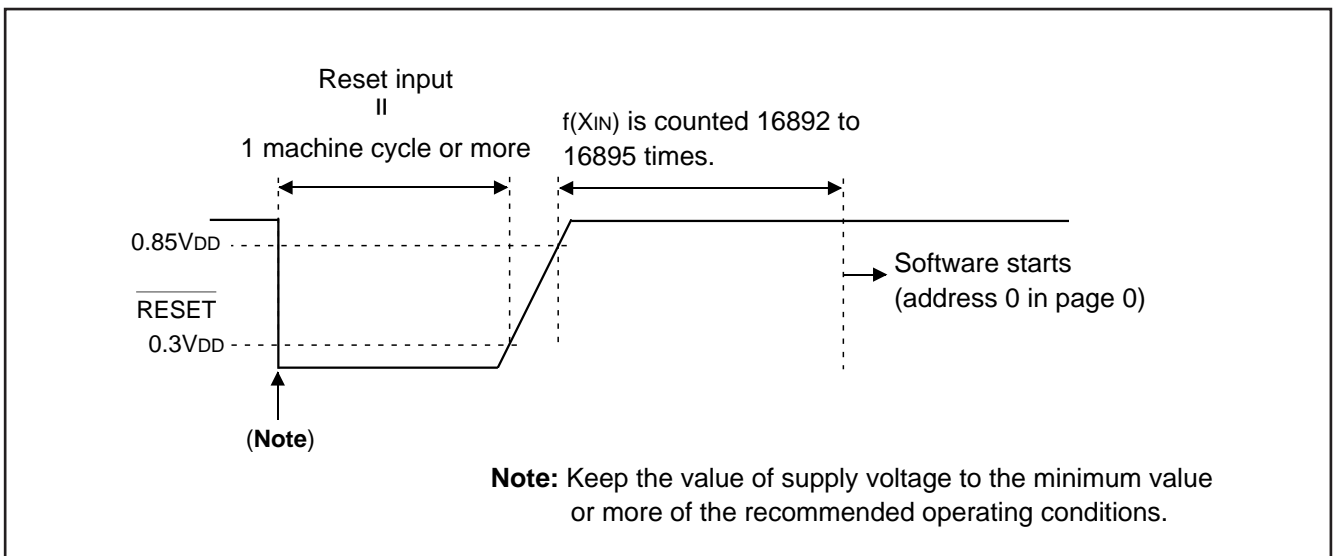

Fig. 33 $\overline{\text{RESET}}$ pin input waveform and reset operation

HARDWARE

FUNCTION BLOCK OPERATIONS

(1) Power-on reset

Reset can be performed automatically at power on (power-on reset) by connecting resistors, a diode, and a capacitor to RESET pin. Connect RESET pin and the external circuit at the shortest distance.

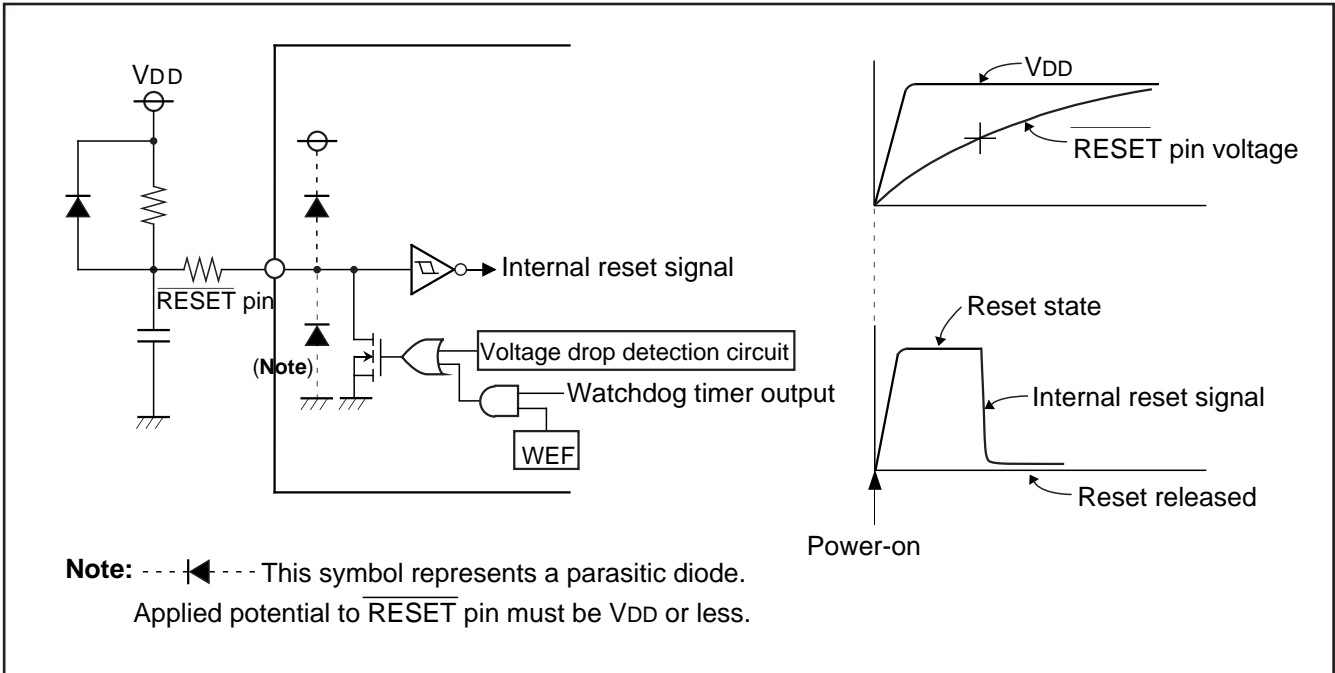

Fig. 34 Power-on reset circuit example

(2) Internal state at reset

Table 19 shows port state at reset, and Figure 35 shows internal state at reset (they are the same after system is released from reset). The contents of timers, registers, flags and RAM except shown in Figure 35 are undefined, so set the initial value to them.

Table 19 Port state at reset

Name	Function	State
D0–D5	D0–D5	High impedance (Note)
D6/CNTR0, D7/CNTR1	D6, D7	
P00–P03	P00–P03	High impedance (Notes 1, 2)
P10–P13	P10–P13	
P20/SCK, P21/SOUT, P22/SIN	P20–P22	High impedance
P30/INT0, P31/INT1	P30, P31	High impedance (Note 1)
P32, P33 (Note 4)	P32, P33	
P40/AIN4–P43/AIN7 (Note 4)	P40–P43	High impedance (Note 1)
P50–P53 (Note 4)	P50–P53	High impedance (Note 3)

Notes 1: Output latch is set to "1."

2: Pull-up transistor is turned OFF.

3: After system is released from reset, port P5 is in the input mode. (Direction register FR0 = 00002)

4: The 4513 Group does not have these ports.

• Program counter (PC)	0 0 0 0 0 0 0 0 0 0 0 0 0 0 0	
Address 0 in page 0 is set to program counter.		
• Interrupt enable flag (INTE)	0	(Interrupt disabled)
• Power down flag (P)	0	
• External 0 interrupt request flag (EXF0)	0	
• External 1 interrupt request flag (EXF1)	0	
• Interrupt control register V1	0 0 0 0	(Interrupt disabled)
• Interrupt control register V2	0 0 0 0	(Interrupt disabled)
• Interrupt control register I1	0 0 0 0	
• Interrupt control register I2	0 0 0 0	
• Timer 1 interrupt request flag (T1F)	0	
• Timer 2 interrupt request flag (T2F)	0	
• Timer 3 interrupt request flag (T3F)	0	
• Timer 4 interrupt request flag (T4F)	0	
• Watchdog timer flags (WDF1, WDF2)	0	
• Watchdog timer enable flag (WEF)	0	
• Timer control register W1	0 0 0 0	(Prescaler and timer 1 stopped)
• Timer control register W2	0 0 0 0	(Timer 2 stopped)
• Timer control register W3	0 0 0 0	(Timer 3 stopped)
• Timer control register W4	0 0 0 0	(Timer 4 stopped)
• Timer control register W6	0 0 0 0	
• Clock control register MR	1 0 0 0	
• Serial I/O transmission/reception completion flag (SIOF)	0	
• Serial I/O mode register J1	0 0 0 0	(External clock selected and serial I/O port not selected)
• Serial I/O register SI	X X X X X X X X	
• A-D conversion completion flag (ADF)	0	
• A-D control register Q1	0 0 0 0	
• A-D control register Q2	0 0 0 0	
• Voltage comparator control register Q3	0 0 0 0	
• Successive comparison register AD	X X X X X X X X X X	
• Comparator register	X X X X X X X X	
• Key-on wakeup control register K0	0 0 0 0	
• Pull-up control register PU0	0 0 0 0	
• Direction register FR0	0 0 0 0	(Port P5: input mode)
• Carry flag (CY)	0	
• Register A	0 0 0 0	
• Register B	0 0 0 0	
• Register D	X X X	
• Register E	X X X X X X X X	
• Register X	0 0 0 0	
• Register Y	0 0 0 0	
• Register Z	X X	
• Stack pointer (SP)	1 1 1	

“X” represents undefined.

Fig. 35 Internal state at reset

HARDWARE

FUNCTION BLOCK OPERATIONS

VOLTAGE DROP DETECTION CIRCUIT

The built-in voltage drop detection circuit is designed to detect a drop in voltage and to reset the microcomputer if the supply voltage drops below a set value.

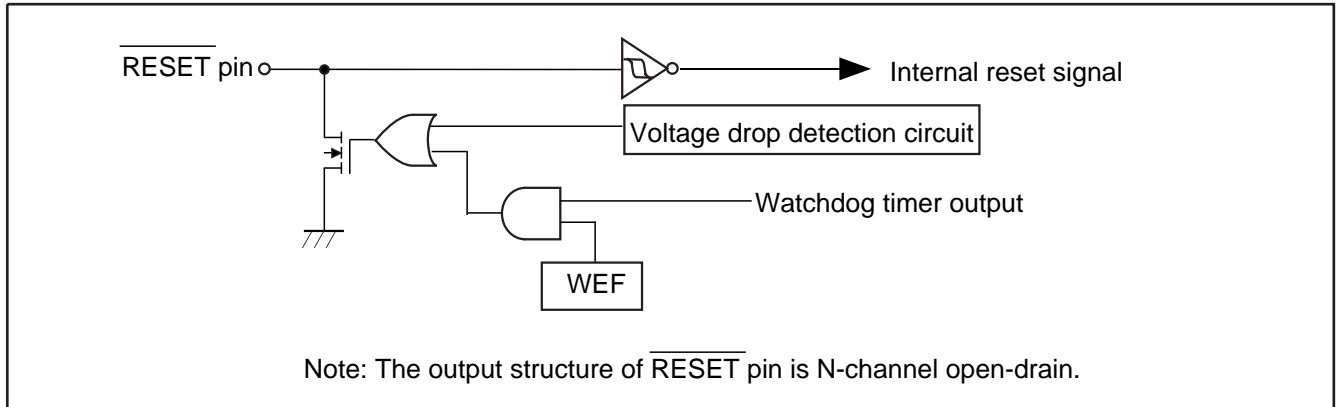

Fig. 36 Voltage drop detection reset circuit

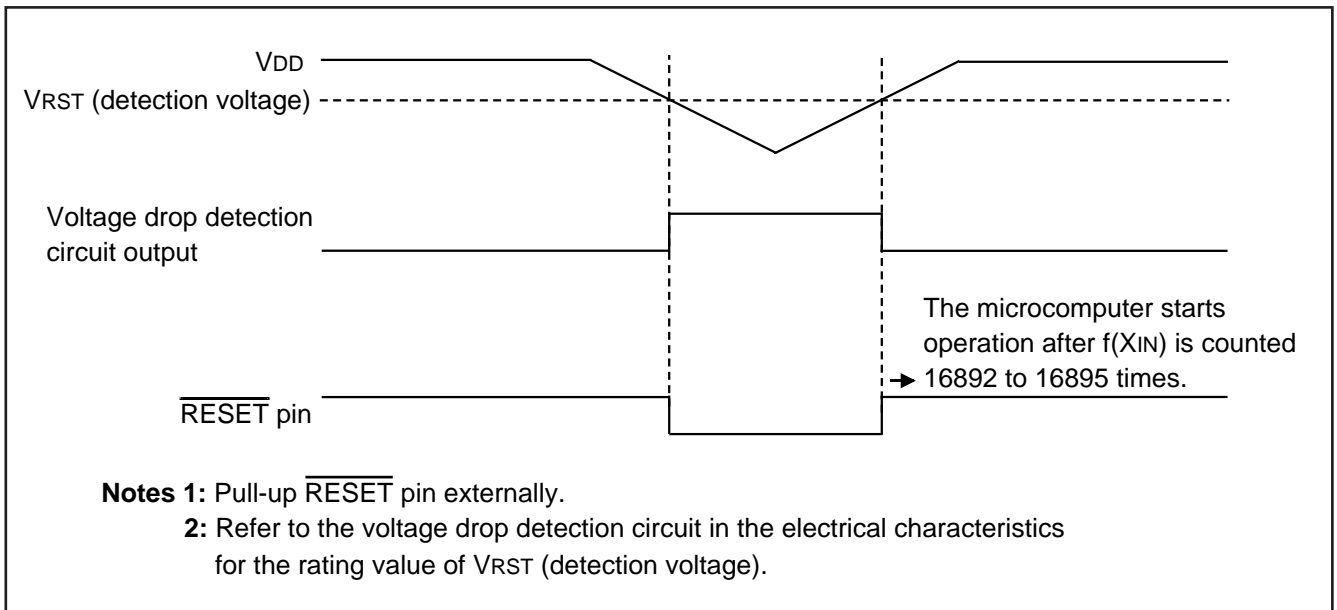

Fig. 37 Voltage drop detection circuit operation waveform

RAM BACK-UP MODE

The 4513/4514 Group has the RAM back-up mode.

When the EPOF and POF instructions are executed continuously, system enters the RAM back-up state. The POF instruction is equal to the NOP instruction when the EPOF instruction is not executed before the POF instruction.

As oscillation stops retaining RAM, the function of reset circuit and states at RAM back-up mode, current dissipation can be reduced without losing the contents of RAM. Table 20 shows the function and states retained at RAM back-up. Figure 38 shows the state transition.

(1) Identification of the start condition

Warm start (return from the RAM back-up state) or cold start (return from the normal reset state) can be identified by examining the state of the power down flag (P) with the SNZP instruction.

(2) Warm start condition

When the external wakeup signal is input after the system enters the RAM back-up state by executing the EPOF and POF instructions continuously, the CPU starts executing the program from address 0 in page 0. In this case, the P flag is "1."

(3) Cold start condition

The CPU starts executing the program from address 0 in page 0 when;

- reset pulse is input to $\overline{\text{RESET}}$ pin, or
- reset by watchdog timer is performed, or
- voltage drop detection circuit detects the voltage drop.

In this case, the P flag is "0."

Table 20 Functions and states retained at RAM back-up

Function	RAM back-up
Program counter (PC), registers A, B, carry flag (CY), stack pointer (SP) (Note 2)	X
Contents of RAM	O
Port level	O
Timer control register W1	X
Timer control registers W2 to W4, W6	O
Clock control register MR	X
Interrupt control registers V1, V2	X
Interrupt control registers I1, I2	O
Timer 1 function	X
Timer 2 function	(Note 3)
Timer 3 function	(Note 3)
Timer 4 function	(Note 3)
A-D conversion function	X
A-D control registers Q1, Q2	O
Voltage comparator function	O (Note 5)
Voltage comparator control register Q3	O
Serial I/O function	X
Serial I/O mode register J1	O
Pull-up control register PU0	O
Key-on wakeup control register K0	O
Direction register FR0	O
External 0 interrupt request flag (EXF0)	X
External 1 interrupt request flag (EXF1)	X
Timer 1 interrupt request flag (T1F)	X
Timer 2 interrupt request flag (T2F)	(Note 3)
Timer 3 interrupt request flag (T3F)	(Note 3)
Timer 4 interrupt request flag (T4F)	(Note 3)
Watchdog timer flags (WDF1, WDF2)	X (Note 4)
Watchdog timer enable flag (WEF)	X (Note 4)
16-bit timer (WDT)	X (Note 4)
A-D conversion completion flag (ADF)	X
Serial I/O transmission/reception completion flag (SIOF)	X
Interrupt enable flag (INTE)	X

Notes 1: "O" represents that the function can be retained, and "X" represents that the function is initialized.

Registers and flags other than the above are undefined at RAM back-up, and set an initial value after returning.

2: The stack pointer (SP) points the level of the stack register and is initialized to "7" at RAM back-up.

3: The state of the timer is undefined.

4: Initialize the watchdog timer with the WRST instruction, and then execute the POF instruction.

5: The state is retained when the voltage comparator function is selected with the voltage comparator control register Q3.

HARDWARE

FUNCTION BLOCK OPERATIONS

(4) Return signal

An external wakeup signal is used to return from the RAM back-up mode because the oscillation is stopped. Table 21 shows the return condition for each return source.

(5) Ports P0 and P1 control registers

- Key-on wakeup control register K0
Register K0 controls the ports P0 and P1 key-on wakeup function. Set the contents of this register through register A with the TK0A instruction. In addition, the TAK0 instruction can be used to transfer the contents of register K0 to register A.
- Pull-up control register PU0
Register PU0 controls the ON/OFF of the ports P0 and P1 pull-up transistor. Set the contents of this register through register A with the TPU0A instruction. In addition, the TAPU0 instruction can be used to transfer the contents of register PU0 to register A.

Table 21 Return source and return condition

	Return source	Return condition	Remarks
External wakeup signal	Ports P0, P1	Return by an external falling edge input (“H”→“L”).	Set the port using the key-on wakeup function selected with register K0 to “H” level before going into the RAM back-up state because the port P0 shares the falling edge detection circuit with port P1.
	Port P30/INT0	Return by an external “H” level or “L” level input. The EXF0 flag is not set.	Select the return level (“L” level or “H” level) with the bit 2 of register I1 according to the external state before going into the RAM back-up state.
	Port P31/INT1	Return by an external “H” level or “L” level input. The EXF1 flag is not set.	Select the return level (“L” level or “H” level) with the bit 2 of register I2 according to the external state before going into the RAM back-up state.

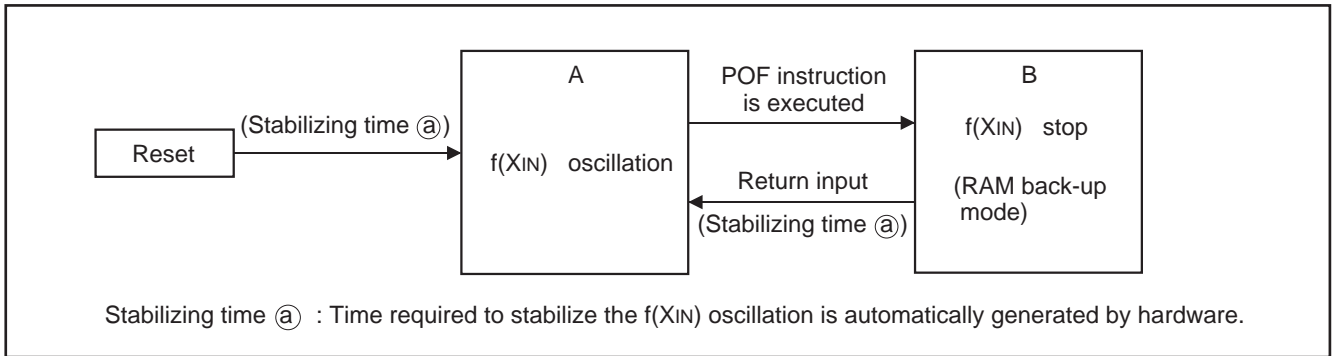

Fig. 38 State transition

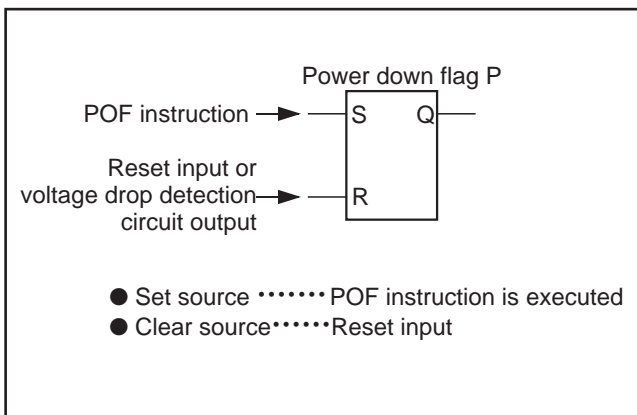

Fig. 39 Set source and clear source of the P flag

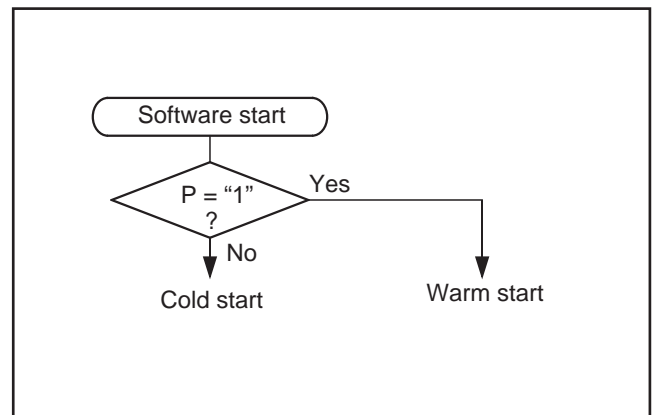

Fig. 40 Start condition identified example using the SNZP instruction

HARDWARE

FUNCTION BLOCK OPERATIONS

Table 22 Key-on wakeup control register, pull-up control register, and interrupt control register

Key-on wakeup control register K0		at reset : 00002	at RAM back-up : state retained	R/W
K03	Pins P12 and P13 key-on wakeup control bit	0	Key-on wakeup not used	
		1	Key-on wakeup used	
K02	Pins P10 and P11 key-on wakeup control bit	0	Key-on wakeup not used	
		1	Key-on wakeup used	
K01	Pins P02 and P03 key-on wakeup control bit	0	Key-on wakeup not used	
		1	Key-on wakeup used	
K00	Pins P00 and P01 key-on wakeup control bit	0	Key-on wakeup not used	
		1	Key-on wakeup used	
Pull-up control register PU0		at reset : 00002	at RAM back-up : state retained	R/W
PU03	Pins P12 and P13 pull-up transistor control bit	0	Pull-up transistor OFF	
		1	Pull-up transistor ON	
PU02	Pins P10 and P11 pull-up transistor control bit	0	Pull-up transistor OFF	
		1	Pull-up transistor ON	
PU01	Pins P02 and P03 pull-up transistor control bit	0	Pull-up transistor OFF	
		1	Pull-up transistor ON	
PU00	Pins P00 and P01 pull-up transistor control bit	0	Pull-up transistor OFF	
		1	Pull-up transistor ON	
Interrupt control register I1		at reset : 00002	at RAM back-up : state retained	R/W
I13	Not used	0	This bit has no function, but read/write is enabled.	
		1		
I12	Interrupt valid waveform for INT0 pin/ return level selection bit (Note 2)	0	Falling waveform ("L" level of INT0 pin is recognized with the SNZ10 instruction)/"L" level	
		1	Rising waveform ("H" level of INT0 pin is recognized with the SNZ10 instruction)/"H" level	
I11	INT0 pin edge detection circuit control bit	0	One-sided edge detected	
		1	Both edges detected	
I10	INT0 pin timer 1 control enable bit	0	Disabled	
		1	Enabled	
Interrupt control register I2		at reset : 00002	at RAM back-up : state retained	R/W
I23	Not used	0	This bit has no function, but read/write is enabled.	
		1		
I22	Interrupt valid waveform for INT1 pin/ return level selection bit (Note 3)	0	Falling waveform ("L" level of INT1 pin is recognized with the SNZ11 instruction)/"L" level	
		1	Rising waveform ("H" level of INT1 pin is recognized with the SNZ11 instruction)/"H" level	
I21	INT1 pin edge detection circuit control bit	0	One-sided edge detected	
		1	Both edges detected	
I20	INT1 pin timer 3 control enable bit	0	Disabled	
		1	Enabled	

Notes 1: "R" represents read enabled, and "W" represents write enabled.

2: When the contents of I12 is changed, the external interrupt request flag EXF0 may be set. Accordingly, clear EXF0 flag with the SNZ0 instruction.

3: When the contents of I22 is changed, the external interrupt request flag EXF1 may be set. Accordingly, clear EXF1 flag with the SNZ1 instruction.

CLOCK CONTROL

The clock control circuit consists of the following circuits.

- System clock generating circuit
- Control circuit to stop the clock oscillation
- Control circuit to switch the middle-speed mode and high-speed mode
- Control circuit to return from the RAM back-up state

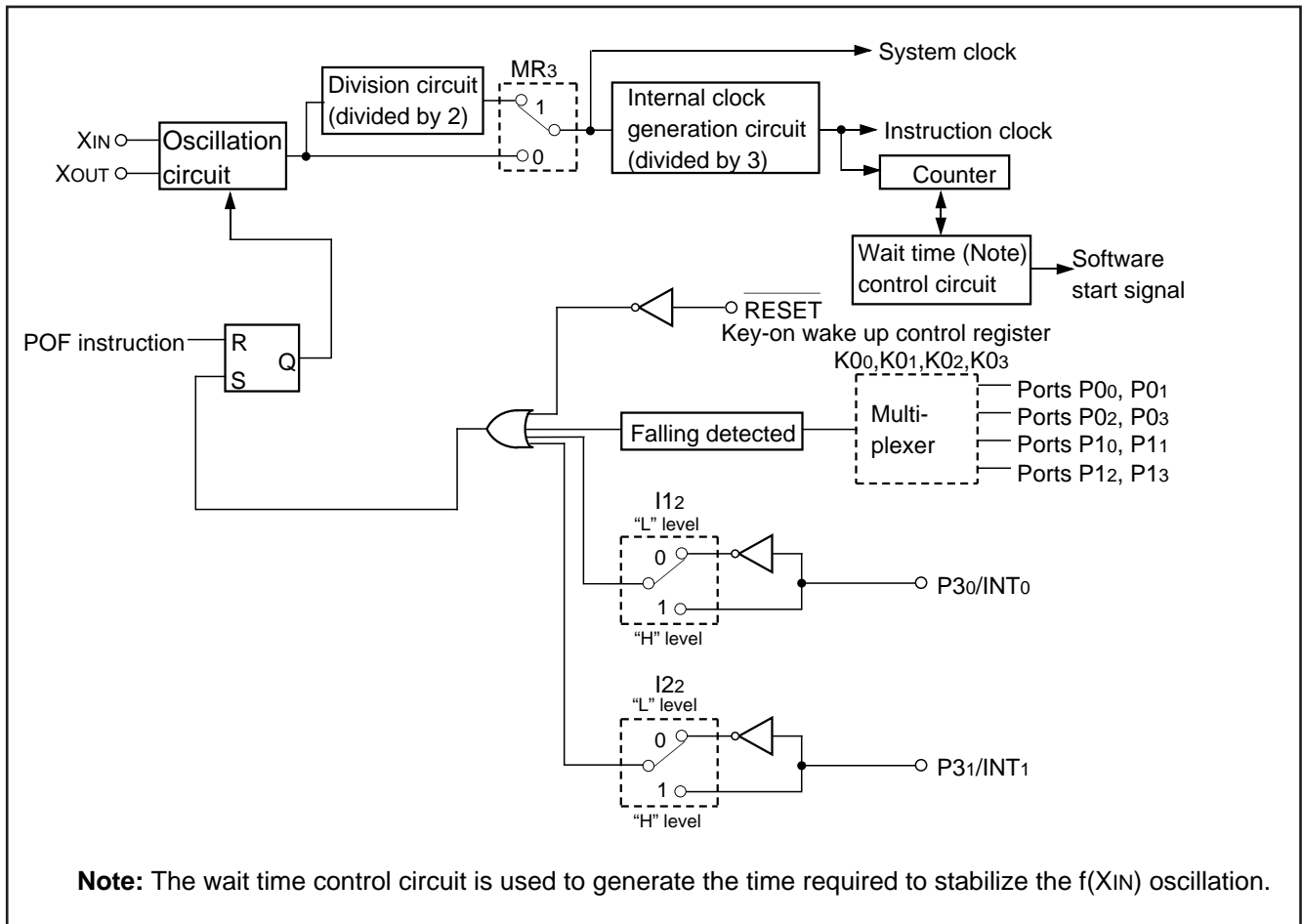

Fig. 41 Clock control circuit structure

Table 23 Clock control register MR

Clock control register MR		at reset : 10002		at RAM back-up : 10002	R/W
MR3	System clock selection bit	0	f(X _{IN}) (high-speed mode)		
		1	f(X _{IN})/2 (middle-speed mode)		
MR2	Not used	0	This bit has no function, but read/write is enabled.		
		1			
MR1	Not used	0	This bit has no function, but read/write is enabled.		
		1			
MR0	Not used	0	This bit has no function, but read/write is enabled.		
		1			

Note : "R" represents read enabled, and "W" represents write enabled.

HARDWARE

FUNCTION BLOCK OPERATIONS/ROM ORDERING METHOD

Clock signal $f(X_{IN})$ is obtained by externally connecting a ceramic resonator.

Connect this external circuit to pins X_{IN} and X_{OUT} at the shortest distance. A feedback resistor is built in between pins X_{IN} and X_{OUT} . When an external clock signal is input, connect the clock source to X_{IN} and leave X_{OUT} open. When using an external clock, the maximum value of external clock oscillating frequency is shown in Table 24.

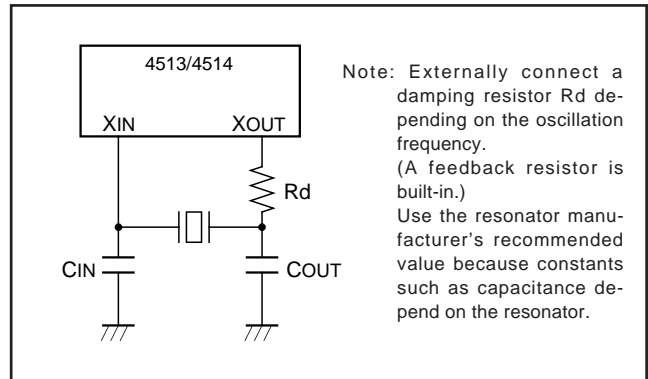

Fig. 42 Ceramic resonator external circuit

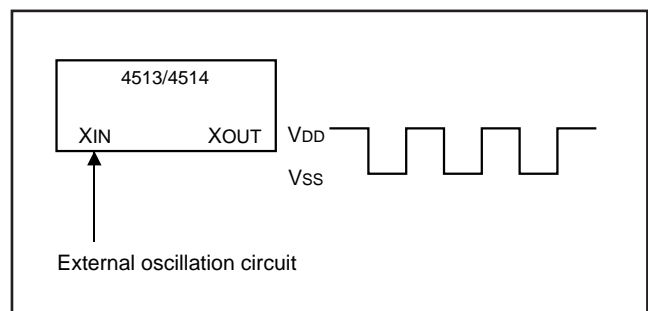

Fig. 43 External clock input circuit

Table 24 Maximum value of external clock oscillation frequency

		Supply voltage	Oscillation frequency (duty ratio)
Mask ROM version	Middle-speed mode	$V_{DD} = 2.0\text{ V to }5.5\text{ V}$	3.0 MHz (40 % to 60 %)
	High-speed mode	$V_{DD} = 4.0\text{ V to }5.5\text{ V}$	3.0 MHz (40 % to 60 %)
		$V_{DD} = 2.5\text{ V to }5.5\text{ V}$	1.0 MHz (40 % to 60 %)
		$V_{DD} = 2.0\text{ V to }5.5\text{ V}$	0.8 MHz (40 % to 60 %)
One Time PROM version	Middle-speed mode	$V_{DD} = 2.5\text{ V to }5.5\text{ V}$	3.0 MHz (40 % to 60 %)
	High-speed mode	$V_{DD} = 4.0\text{ V to }5.5\text{ V}$	3.0 MHz (40 % to 60 %)
		$V_{DD} = 2.5\text{ V to }5.5\text{ V}$	1.0 MHz (40 % to 60 %)

ROM ORDERING METHOD

Please submit the information described below when ordering Mask ROM.

- (1) Mask ROM Order Confirmation Form 1
- (2) Data to be written into mask ROM EPROM
(three sets containing the identical data)
- (3) Mark Specification Form 1

LIST OF PRECAUTIONS

① Noise and latch-up prevention

Connect a capacitor on the following condition to prevent noise and latch-up;

- connect a bypass capacitor (approx. 0.1 μ F) between pins VDD and VSS at the shortest distance,
- equalize its wiring in width and length, and
- use relatively thick wire.

In the One Time PROM version, CNVSS pin is also used as VPP pin. Accordingly, when using this pin, connect this pin to VSS through a resistor about 5 k Ω in series at the shortest distance.

② Prescaler

Stop the prescaler operation to change its frequency dividing ratio.

③ Timer count source

Stop timer 1, 2, 3, or 4 counting to change its count source.

④ Reading the count value

Stop timer 1, 2, 3, or 4 counting and then execute the TAB1, TAB2, TAB3, or TAB4 instruction to read its data.

⑤ Writing to reload registers R1 and R3

When writing data to reload registers R1 or R3 while timer 1 or timer 3 is operating, avoid a timing when timer 1 or timer 3 underflows.

⑥ P30/INT0 pin

When the interrupt valid waveform of the P30/INT0 pin is changed with the bit 2 of register I1 in software, be careful about the following notes.

- Clear the bit 0 of register V1 to "0" before the interrupt valid waveform of P30/INT0 pin is changed with the bit 2 of register I1 (refer to Figure 44①).
- Depending on the input state of the P30/INT0 pin, the external 0 interrupt request flag (EXF0) may be set when the interrupt valid waveform is changed. Accordingly, clear bit 2 of register I1, and execute the SNZ0 instruction to clear the EXF0 flag after executing at least one instruction (refer to Figure 44②).

```

:
LA 4 ; (XXX02)
TV1A ; The SNZ0 instruction is valid .....①
LA 4 ;
TI1A ; Interrupt valid waveform is changed
NOP .....②
SNZ0 ; The SNZ0 instruction is executed
NOP
:
X : this bit is not related to the setting of INTO pin.
    
```

Fig. 44 External 0 interrupt program example

⑦ P31/INT1 pin

When the interrupt valid waveform of P31/INT1 pin is changed with the bit 2 of register I2 in software, be careful about the following notes.

- Clear the bit 1 of register V1 to "0" before the interrupt valid waveform of P31/INT1 pin is changed with the bit 2 of register I2 (refer to Figure 45③).
- Depending on the input state of the P31/INT1 pin, the external 1 interrupt request flag (EXF1) may be set when the interrupt valid waveform is changed. Accordingly, clear bit 2 of register I2 and execute the SNZ1 instruction to clear the EXF1 flag after executing at least one instruction (refer to Figure 45④).

```

:
LA 8 ; (XX0X2)
TV1A ; The SNZ1 instruction is valid .....③
LA 8 ;
TI2A ; Change of the interrupt valid waveform
NOP .....④
SNZ1 ; The SNZ1 instruction is executed
NOP
:
X : this bit is not related to the setting of INT1.
    
```

Fig. 45 External 1 interrupt program example

⑧ One Time PROM version

The operating power voltage of the One Time PROM version is 2.5 V to 5.5 V.

⑨ Multifunction

The input of D6, D7, P20–P22, I/O of P30 and P31, input of CMP0-, CMP0+, CMP1-, CMP1+, and I/O of P40–P43 can be used even when CNTR0, CNTR1, SCK, SOUT, SIN, INT0, INT1, AIN0–AIN3 and AIN4–AIN7 are selected.

HARDWARE

LIST OF PRECAUTIONS

⑩ A-D converter-1

When the operating mode of the A-D converter is changed from the comparator mode to the A-D conversion mode with the bit 3 of register Q2 in a program, be careful about the following notes.

- Clear the bit 2 of register V2 to "0" to change the operating mode of the A-D converter from the comparator mode to the A-D conversion mode with the bit 3 of register Q2 (refer to Figure 46⑤).
- The A-D conversion completion flag (ADF) may be set when the operating mode of the A-D converter is changed from the comparator mode to the A-D conversion mode. Accordingly, set a value to register Q2, and execute the SNZAD instruction to clear the ADF flag.

Do not change the operating mode (both A-D conversion mode and comparator mode) of A-D converter with the bit 3 of register Q2 during operating the A-D converter.

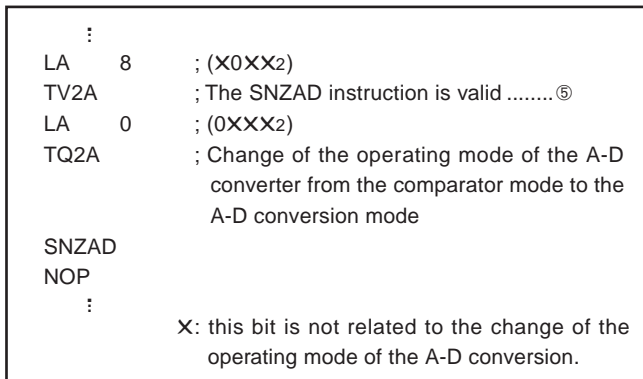

Fig. 46 A-D converter operating mode program example

⑪ A-D converter-2

Each analog input pin is equipped with a capacitor which is used to compare the analog voltage. Accordingly, when the analog voltage is input from the circuit with high-impedance and, charge/discharge noise is generated and the sufficient A-D accuracy may not be obtained. Therefore, reduce the impedance or, connect a capacitor (0.01 μF to 1 μF) to analog input pins (Figure 47).

When the overvoltage applied to the A-D conversion circuit may occur, connect an external circuit in order to keep the voltage within the rated range as shown the Figure 48. In addition, test the application products sufficiently.

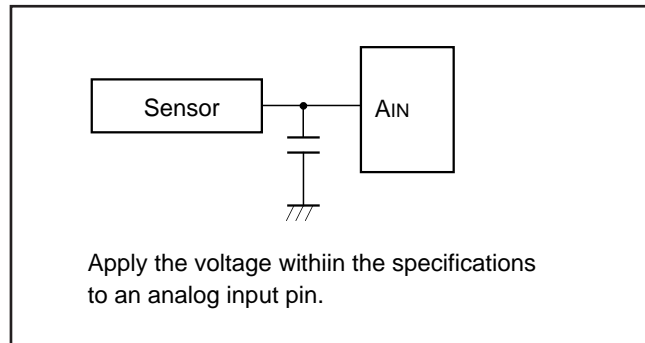

Fig. 47 Analog input external circuit example-1

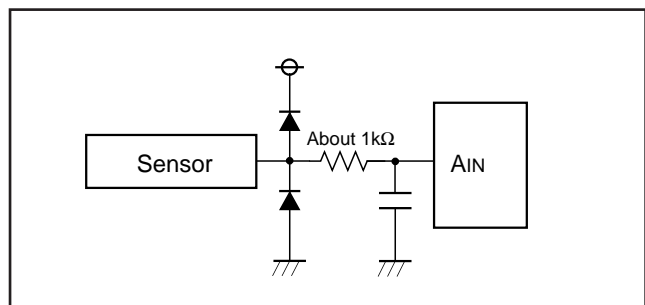

Fig. 48 Analog input external circuit example-2

⑫ POF instruction

Execute the POF instruction immediately after executing the EPOF instruction to enter the RAM back-up.

Note that system cannot enter the RAM back-up state when executing only the POF instruction.

Be sure to disable interrupts by executing the DI instruction before executing the EPOF instruction.

⑬ Analog input pins

Note the following when using the analog input pins also for I/O port P4 functions:

- Even when P40/AIN4–P43/AIN7 are set to pins for analog input, they continue to function as P40–P43 I/O. Accordingly, when any of them are used as I/O port P4 and others are used as analog input pins, make sure to set the outputs of pins that are set for analog input to "1." Also, the port input function of the pin functions as an analog input is undefined.
- TALA instruction
When the TALA instruction is executed, the low-order 2 bits of register AD is transferred to the high-order 2 bits of register A, simultaneously, the low-order 2 bits of register A is "0."

⑭ Program counter

Make sure that the PCH does not specify after the last page of the built-in ROM.

⑮ Port P3

In the 4513 Group, when the IAP3 instruction is executed, note that the high-order 2 bits of register A is undefined.

⑬ Voltage comparator function

When the voltage comparator function is valid with the voltage comparator control register Q3, it is operating even in the RAM back-up mode. Accordingly, be careful about such state because it causes the increase of the operation current in the RAM back-up mode.

In order to reduce the operation current in the RAM back-up mode, invalidate (bits 2 and 3 of register Q3 = "0") the voltage comparator function by software before the POF instruction is executed.

Also, while the voltage comparator function is valid, current is always consumed by voltage comparator. On the system required for the low-power dissipation, invalidate the voltage comparator when it is unused by software.

⑭ Register Q3

Bits 0 and 1 of register Q3 can be only read. Note that they cannot be written.

⑮ Reading the comparison result of voltage comparator

Read the voltage comparator comparison result from register Q3 after the voltage comparator response time (max. 20 μ s) is passed from the voltage comparator function become valid.

HARDWARE

SYMBOL

SYMBOL

The symbols shown below are used in the following instruction function table and instruction list.

Symbol	Contents	Symbol	Contents
A	Register A (4 bits)	T1F	Timer 1 interrupt request flag
B	Register B (4 bits)	T2F	Timer 2 interrupt request flag
DR	Register D (3 bits)	T3F	Timer 3 interrupt request flag
E	Register E (8 bits)	T4F	Timer 4 interrupt request flag
Q1	A-D control register Q1 (4 bits)	WDF1	Watchdog timer flag
Q2	A-D control register Q2 (4 bits)	WEF	Watchdog timer enable flag
Q3	Voltage comparator control register Q3 (4 bits)	INTE	Interrupt enable flag
AD	Successive comparison register AD (10 bits)	EXF0	External 0 interrupt request flag
J1	Serial I/O mode register J1 (4 bits)	EXF1	External 1 interrupt request flag
SI	Serial I/O register SI (8 bits)	P	Power down flag
V1	Interrupt control register V1 (4 bits)	ADF	A-D conversion completion flag
V2	Interrupt control register V2 (4 bits)	SIOF	Serial I/O transmission/reception completion flag
I1	Interrupt control register I1 (4 bits)		
I2	Interrupt control register I2 (4 bits)	D	Port D (8 bits)
W1	Timer control register W1 (4 bits)	P0	Port P0 (4 bits)
W2	Timer control register W2 (4 bits)	P1	Port P1 (4 bits)
W3	Timer control register W3 (4 bits)	P2	Port P2 (3 bits)
W4	Timer control register W4 (4 bits)	P3	Port P3 (4 bits)
W6	Timer control register W6 (4 bits)	P4	Port P4 (4 bits)
MR	Clock control register MR (4 bits)	P5	Port P5 (4 bits)
K0	Key-on wakeup control register K0 (4 bits)		
PU0	Pull-up control register PU0 (4 bits)	x	Hexadecimal variable
FR0	Direction register FR0 (4 bits)	y	Hexadecimal variable
X	Register X (4 bits)	z	Hexadecimal variable
Y	Register Y (4 bits)	p	Hexadecimal variable
Z	Register Z (2 bits)	n	Hexadecimal constant
DP	Data pointer (10 bits) (It consists of registers X, Y, and Z)	i	Hexadecimal constant
PC	Program counter (14 bits)	j	Hexadecimal constant
PC _H	High-order 7 bits of program counter	A3A2A1A0	Binary notation of hexadecimal variable A (same for others)
PC _L	Low-order 7 bits of program counter		
SK	Stack register (14 bits X 8)	←	Direction of data movement
SP	Stack pointer (3 bits)	↔	Data exchange between a register and memory
CY	Carry flag	?	Decision of state shown before “?”
R1	Timer 1 reload register	()	Contents of registers and memories
R2	Timer 2 reload register	—	Negate, Flag unchanged after executing instruction
R3	Timer 3 reload register	M(DP)	RAM address pointed by the data pointer
R4	Timer 4 reload register	a	Label indicating address a6 a5 a4 a3 a2 a1 a0
T1	Timer 1	p, a	Label indicating address a6 a5 a4 a3 a2 a1 a0 in page p5 p4 p3 p2 p1 p0
T2	Timer 2	C	Hex. C + Hex. number x (also same for others)
T3	Timer 3	+	
T4	Timer 4	x	

Note : The 4513/4514 Group just invalidates the next instruction when a skip is performed. The contents of program counter is not increased by 2. Accordingly, the number of cycles does not change even if skip is not performed. However, the cycle count becomes “1” if the TABP p, RT, or RTS instruction is skipped.

LIST OF INSTRUCTION FUNCTION

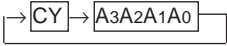
Grouping	Mnemonic	Function	Grouping	Mnemonic	Function	Grouping	Mnemonic	Function	
Register to register transfer	TAB	$(A) \leftarrow (B)$	RAM to register transfer	XAMI j	$(A) \leftarrow \rightarrow (M(DP))$ $(X) \leftarrow (X)EXOR(j)$ j = 0 to 15 $(Y) \leftarrow (Y) + 1$	Bit operation	SB j	$(Mj(DP)) \leftarrow 1$ j = 0 to 3	
	TBA	$(B) \leftarrow (A)$		TMA j	$(M(DP)) \leftarrow (A)$ $(X) \leftarrow (X)EXOR(j)$ j = 0 to 15		RB j	$(Mj(DP)) \leftarrow 0$ j = 0 to 3	
	TAY	$(A) \leftarrow (Y)$		Arithmetic operation	LA n		$(A) \leftarrow n$ n = 0 to 15	Comparison operation	SEAM
	TYA	$(Y) \leftarrow (A)$			TABP p	$(SP) \leftarrow (SP) + 1$ $(SK(SP)) \leftarrow (PC)$ $(PCH) \leftarrow p$ $(PCL) \leftarrow (DR2-DR0, A3-A0)$ $(B) \leftarrow (ROM(PC))_{7-4}$ $(A) \leftarrow (ROM(PC))_{3-0}$ $(PC) \leftarrow (SK(SP))$ $(SP) \leftarrow (SP) - 1$	SEA n		$(A) = n ?$ n = 0 to 15
	TEAB	$(E7-E4) \leftarrow (B)$ $(E3-E0) \leftarrow (A)$			AM	$(A) \leftarrow (A) + (M(DP))$	Branch operation	B a	$(PCL) \leftarrow a6-a0$
	TABE	$(B) \leftarrow (E7-E4)$ $(A) \leftarrow (E3-E0)$			AMC	$(A) \leftarrow (A) + (M(DP)) + (CY)$ $(CY) \leftarrow \text{Carry}$		BL p, a	$(PCH) \leftarrow p$ $(PCL) \leftarrow a6-a0$
	TDA	$(DR2-DR0) \leftarrow (A2-A0)$			A n	$(A) \leftarrow (A) + n$ n = 0 to 15		BLA p	$(PCH) \leftarrow p$ $(PCL) \leftarrow (DR2-DR0, A3-A0)$
	TAD	$(A2-A0) \leftarrow (DR2-DR0)$ $(A3) \leftarrow 0$			AND	$(A) \leftarrow (A) AND (M(DP))$	Subroutine operation	BM a	$(SP) \leftarrow (SP) + 1$ $(SK(SP)) \leftarrow (PC)$ $(PCH) \leftarrow 2$ $(PCL) \leftarrow a6-a0$
	TAZ	$(A1, A0) \leftarrow (Z1, Z0)$ $(A3, A2) \leftarrow 0$			OR	$(A) \leftarrow (A) OR (M(DP))$		BML p, a	$(SP) \leftarrow (SP) + 1$ $(SK(SP)) \leftarrow (PC)$ $(PCH) \leftarrow p$ $(PCL) \leftarrow a6-a0$
	TAX	$(A) \leftarrow (X)$		SC	$(CY) \leftarrow 1$	BMLA p		$(SP) \leftarrow (SP) + 1$ $(SK(SP)) \leftarrow (PC)$ $(PCH) \leftarrow p$ $(PCL) \leftarrow (DR2-DR0, A3-A0)$	
TASP	$(A2-A0) \leftarrow (SP2-SP0)$ $(A3) \leftarrow 0$	RC	$(CY) \leftarrow 0$	Return operation	RTI	$(PC) \leftarrow (SK(SP))$ $(SP) \leftarrow (SP) - 1$			
RAM addresses	LXY x, y	$(X) \leftarrow x, x = 0 \text{ to } 15$ $(Y) \leftarrow y, y = 0 \text{ to } 15$	SZC		$(CY) = 0 ?$	RT	$(PC) \leftarrow (SK(SP))$ $(SP) \leftarrow (SP) - 1$		
	LZ z	$(Z) \leftarrow z, z = 0 \text{ to } 3$	CMA		$(A) \leftarrow (\bar{A})$	RTS	$(PC) \leftarrow (SK(SP))$ $(SP) \leftarrow (SP) - 1$		
	INY	$(Y) \leftarrow (Y) + 1$	RAR						
	DEY	$(Y) \leftarrow (Y) - 1$							
RAM to register transfer	TAM j	$(A) \leftarrow (M(DP))$ $(X) \leftarrow (X)EXOR(j)$ j = 0 to 15							
	XAM j	$(A) \leftarrow \rightarrow (M(DP))$ $(X) \leftarrow (X)EXOR(j)$ j = 0 to 15							
	XAMD j	$(A) \leftarrow \rightarrow (M(DP))$ $(X) \leftarrow (X)EXOR(j)$ j = 0 to 15 $(Y) \leftarrow (Y) - 1$							

HARDWARE

LIST OF INSTRUCTION FUNCTION

LIST OF INSTRUCTION FUNCTION (continued)

Group- ing	Mnemonic	Function	Group- ing	Mnemonic	Function	Group- ing	Mnemonic	Function					
Interrupt operation	DI	(INTE) ← 0	Timer operation	TAW4	(A) ← (W4)	Timer operation	SNZT1	(T1F) = 1 ? After skipping (T1F) ← 0					
	EI	(INTE) ← 1		TW4A	(W4) ← (A)		SNZT2	(T2F) = 1 ? After skipping (T2F) ← 0					
	SNZ0	(EXF0) = 1 ? After skipping (EXF0) ← 0		TAW6	(A) ← (W6)		TW6A	(W6) ← (A)	SNZT3	(T3F) = 1 ? After skipping (T3F) ← 0			
	SNZ1	(EXF1) = 1 ? After skipping (EXF1) ← 0		TAB1	(B) ← (T17–T14) (A) ← (T13–T10)		T1AB	(R17–R14) ← (B) (T17–T14) ← (B) (R13–R10) ← (A) (T13–T10) ← (A)	SNZT4	(T4F) = 1 ? After skipping (T4F) ← 0			
	SNZI0	I12 = 1 : (INT0) = “H” ? I12 = 0 : (INT0) = “L” ?		TAB2	(B) ← (T27–T24) (A) ← (T23–T20)	T2AB	(R27–R24) ← (B) (T27–T24) ← (B) (R23–R20) ← (A) (T23–T20) ← (A)	Input/Output operation	IAP0	(A) ← (P0)			
	SNZI1	I22 = 1 : (INT1) = “H” ? I22 = 0 : (INT1) = “L” ?		TAB3	(B) ← (T37–T34) (A) ← (T33–T30)				OP0A	(P0) ← (A)	IAP1	(A) ← (P1)	
	TAV1	(A) ← (V1)		T3AB	(R37–R34) ← (B) (T37–T34) ← (B) (R33–R30) ← (A) (T33–T30) ← (A)	OP1A	(P1) ← (A)		IAP2	(A2–A0) ← (P22–P20) (A3) ← 0			
	TV1A	(V1) ← (A)		TAB4	(B) ← (T47–T44) (A) ← (T43–T40)	T4AB	(R47–R44) ← (B) (T47–T44) ← (B) (R43–R40) ← (A) (T43–T40) ← (A)		OP3A	(P3) ← (A)			
	TAV2	(A) ← (V2)		TR1AB	(R17–R14) ← (B) (R13–R10) ← (A)	TR3AB	(R37–R34) ← (B) (R33–R30) ← (A)		IAP4*	(A) ← (P4)			
	TV2A	(V2) ← (A)		Timer operation			OP4A*		(P4) ← (A)	IAP5*	(A) ← (P5)		
	TAI1	(A) ← (I1)					OP5A*		(P5) ← (A)	CLD	(D) ← 1	RD	(D(Y)) ← 0 (Y) = 0 to 7
	TI1A	(I1) ← (A)					SD		(D(Y)) ← 1 (Y) = 0 to 7	SZD	(D(Y)) = 0 ? (Y) = 0 to 7		
	TAI2	(A) ← (I2)											
	TI2A	(I2) ← (A)											
Timer operation	TAW1	(A) ← (W1)											
	TW1A	(W1) ← (A)											
	TAW2	(A) ← (W2)											
	TW2A	(W2) ← (A)											
	TAW3	(A) ← (W3)											
	TW3A	(W3) ← (A)											

*: The 4513 Group does not have these instructions.

LIST OF INSTRUCTION FUNCTION (continued)

Grouping	Mnemonic	Function	Grouping	Mnemonic	Function	
Input/Output operation	TK0A	(K0) ← (A)	A-D conversion operation	TABAD	(A) ← (AD5-AD2) (B) ← (AD9-AD6) However, in the comparator mode, (A) ← (AD3-AD0) (B) ← (AD7-AD4)	
	TAK0	(A) ← (K0)		TALA	(A) ← (AD1, AD0, 0, 0)	
	TPU0A	(PU0) ← (A)		TADAB	(AD3-AD0) ← (A) (AD7-AD4) ← (B)	
	TAPU0	(A) ← (PU0)		TAQ1	(A) ← (Q1)	
	TFR0A*	(FR0) ← (A)		TQ1A	(Q1) ← (A)	
Serial I/O control operation	TABSI	(A) ← (SI3-SI0) (B) ← (SI7-SI4)		ADST	(ADF) ← 0 A-D conversion starting	
	TSIAB	(SI3-SI0) ← (A) (SI7-SI4) ← (B)		SNZAD	(ADF) = 1 ? After skipping (ADF) ← 0	
	TAJ1	(A) ← (J1)		TAQ2	(A) ← (Q2)	
	TJ1A	(J1) ← (A)		TQ2A	(Q2) ← (A)	
	SST	(SIOF) ← 0 Serial I/O starting				
	SNZSI	(SIOF) = 1 ? After skipping (SIOF) ← 0				
				Other operation	NOP	(PC) ← (PC) + 1
					POF	RAM back-up
					EPOF	POF instruction valid
					SNZP	(P) = 1 ?
			WRST		(WDF1) ← 0, (WEF) ← 1	
			TAMR		(A) ← (MR)	
			TMRA		(MR) ← (A)	
			TAQ3		(A) ← (Q3)	
			TQ3A	(Q33, Q32) ← (A3, A2) (Q31) ← (CMP1 comparison result) (Q30) ← (CMP0 comparison result)		

*: The 4513 Group does not have these instructions.

HARDWARE

INSTRUCTION CODE TABLE

INSTRUCTION CODE TABLE (for 4513 Group)

D3-D0	D9-D4 Hex. notation	000000	000001	000010	000011	000100	000101	000110	000111	001000	001001	001010	001011	001100	001101	001110	001111	010000	011000
		00	01	02	03	04	05	06	07	08	09	0A	0B	0C	0D	0E	0F	10-17	18-1F
0000	0	NOP	BLA	SZB 0	BMLA	-	TASP	A 0	LA 0	TABP 0	TABP 16***	TABP 32**	TABP 48*	BML	BML***	BL	BL***	BM	B
0001	1	-	CLD	SZB 1	-	-	TAD	A 1	LA 1	TABP 1	TABP 17***	TABP 33**	TABP 49*	BML	BML***	BL	BL***	BM	B
0010	2	POF	-	SZB 2	-	-	TAX	A 2	LA 2	TABP 2	TABP 18***	TABP 34**	TABP 50*	BML	BML***	BL	BL***	BM	B
0011	3	SNZP	INY	SZB 3	-	-	TAZ	A 3	LA 3	TABP 3	TABP 19***	TABP 35**	TABP 51*	BML	BML***	BL	BL***	BM	B
0100	4	DI	RD	SZD	-	RT	TAV1	A 4	LA 4	TABP 4	TABP 20***	TABP 36**	TABP 52*	BML	BML***	BL	BL***	BM	B
0101	5	EI	SD	SEAn	-	RTS	TAV2	A 5	LA 5	TABP 5	TABP 21***	TABP 37**	TABP 53*	BML	BML***	BL	BL***	BM	B
0110	6	RC	-	SEAM	-	RTI	-	A 6	LA 6	TABP 6	TABP 22***	TABP 38**	TABP 54*	BML	BML***	BL	BL***	BM	B
0111	7	SC	DEY	-	-	-	-	A 7	LA 7	TABP 7	TABP 23***	TABP 39**	TABP 55*	BML	BML***	BL	BL***	BM	B
1000	8	-	AND	-	SNZ0	LZ 0	-	A 8	LA 8	TABP 8	TABP 24***	TABP 40**	TABP 56*	BML	BML***	BL	BL***	BM	B
1001	9	-	OR	TDA	SNZ1	LZ 1	-	A 9	LA 9	TABP 9	TABP 25***	TABP 41**	TABP 57*	BML	BML***	BL	BL***	BM	B
1010	A	AM	TEAB	TABE	SNZ10	LZ 2	-	A 10	LA 10	TABP 10	TABP 26***	TABP 42**	TABP 58*	BML	BML***	BL	BL***	BM	B
1011	B	AMC	-	-	SNZ11	LZ 3	EPOF	A 11	LA 11	TABP 11	TABP 27***	TABP 43**	TABP 59*	BML	BML***	BL	BL***	BM	B
1100	C	TYA	CMA	-	-	RB 0	SB 0	A 12	LA 12	TABP 12	TABP 28***	TABP 44**	TABP 60*	BML	BML***	BL	BL***	BM	B
1101	D	-	RAR	-	-	RB 1	SB 1	A 13	LA 13	TABP 13	TABP 29***	TABP 45**	TABP 61*	BML	BML***	BL	BL***	BM	B
1110	E	TBA	TAB	-	TV2A	RB 2	SB 2	A 14	LA 14	TABP 14	TABP 30***	TABP 46**	TABP 62*	BML	BML***	BL	BL***	BM	B
1111	F	-	TAY	SZC	TV1A	RB 3	SB 3	A 15	LA 15	TABP 15	TABP 31***	TABP 47**	TABP 63*	BML	BML***	BL	BL***	BM	B

The above table shows the relationship between machine language codes and machine language instructions. D3-D0 show the low-order 4 bits of the machine language code, and D9-D4 show the high-order 6 bits of the machine language code. The hexadecimal representation of the code is also provided. There are one-word instructions and two-word instructions, but only the first word of each instruction is shown. Do not use code marked “-.”

The codes for the second word of a two-word instruction are described below.

	The second word
BL	10 paaa aaaa
BML	10 paaa aaaa
BLA	10 pp00 pppp
BMLA	10 pp00 pppp
SEA	00 0111 nnnn
SZD	00 0010 1011

- *, **, and *** cannot be used in the M34513M2-XXXSP/FP.
- * and ** cannot be used in the M34513M4-XXXSP/FP.
- * and ** cannot be used in the M34513E4FP.
- * cannot be used in the M34513M6-XXXFP.

INSTRUCTION CODE TABLE (continued) (for 4513 Group)

D ₃ -D ₀	Hex. notation	D ₉ -D ₄	100000	100001	100010	100011	100100	100101	100110	100111	101000	101001	101010	101011	101100	101101	101110	101111	110000	111111
		20	21	22	23	24	25	26	27	28	29	2A	2B	2C	2D	2E	2F	30-3F		
0000	0	-	TW3A	OP0A	T1AB	-	TAW6	IAP0	TAB1	SNZT1	-	WRST	TMA0	TAM0	XAM0	XAMI0	XAMD0	LXY		
0001	1	-	TW4A	OP1A	T2AB	-	-	IAP1	TAB2	SNZT2	-	-	TMA1	TAM1	XAM1	XAMI1	XAMD1	LXY		
0010	2	TJ1A	-	-	T3AB	TAJ1	TAMR	IAP2	TAB3	SNZT3	-	-	TMA2	TAM2	XAM2	XAMI2	XAMD2	LXY		
0011	3	-	TW6A	OP3A	T4AB	-	TAI1	IAP3	TAB4	SNZT4	-	-	TMA3	TAM3	XAM3	XAMI3	XAMD3	LXY		
0100	4	TQ1A	-	-	-	TAQ1	TAI2	-	-	-	-	-	TMA4	TAM4	XAM4	XAMI4	XAMD4	LXY		
0101	5	TQ2A	-	-	-	TAQ2	-	-	-	-	-	-	TMA5	TAM5	XAM5	XAMI5	XAMD5	LXY		
0110	6	TQ3A	TMRA	-	-	TAQ3	TAK0	-	-	-	-	-	TMA6	TAM6	XAM6	XAMI6	XAMD6	LXY		
0111	7	-	TI1A	-	-	-	TAPU0	-	-	SNZAD	-	-	TMA7	TAM7	XAM7	XAMI7	XAMD7	LXY		
1000	8	-	TI2A	-	TSIAB	-	-	-	TABS1	SNZSI	-	-	TMA8	TAM8	XAM8	XAMI8	XAMD8	LXY		
1001	9	-	-	-	TADAB	TALA	-	-	TABAD	-	-	-	TMA9	TAM9	XAM9	XAMI9	XAMD9	LXY		
1010	A	-	-	-	-	-	-	-	-	-	-	-	TMA10	TAM10	XAM10	XAMI10	XAMD10	LXY		
1011	B	-	TK0A	-	TR3AB	TAW1	-	-	-	-	-	-	TMA11	TAM11	XAM11	XAMI11	XAMD11	LXY		
1100	C	-	-	-	-	TAW2	-	-	-	-	-	-	TMA12	TAM12	XAM12	XAMI12	XAMD12	LXY		
1101	D	-	-	TPU0A	-	TAW3	-	-	-	-	-	-	TMA13	TAM13	XAM13	XAMI13	XAMD13	LXY		
1110	E	TW1A	-	-	-	TAW4	-	-	-	-	SST	-	TMA14	TAM14	XAM14	XAMI14	XAMD14	LXY		
1111	F	TW2A	-	-	TR1AB	-	-	-	-	-	ADST	-	TMA15	TAM15	XAM15	XAMI15	XAMD15	LXY		

The above table shows the relationship between machine language codes and machine language instructions. D₃-D₀ show the low-order 4 bits of the machine language code, and D₉-D₄ show the high-order 6 bits of the machine language code. The hexadecimal representation of the code is also provided. There are one-word instructions and two-word instructions, but only the first word of each instruction is shown. Do not use code marked "-."

The codes for the second word of a two-word instruction are described below.

	The second word	
BL	10	paaa aaaa
BML	10	paaa aaaa
BLA	10	pp00 pppp
BMLA	10	pp00 pppp
SEA	00	0111 nnnn
SZD	00	0010 1011

HARDWARE

INSTRUCTION CODE TABLE

INSTRUCTION CODE TABLE (for 4514 Group)

D3-D0	Hex. notation	D9-D4																010000	011000
		00	01	02	03	04	05	06	07	08	09	0A	0B	0C	0D	0E	0F	010111	011111
0000	0	NOP	BLA	SZB 0	BMLA	-	TASP	A 0	LA 0	TABP 0	TABP 16	TABP 32	TABP 48*	BML	BML	BL	BL	BM	B
0001	1	-	CLD	SZB 1	-	-	TAD	A 1	LA 1	TABP 1	TABP 17	TABP 33	TABP 49*	BML	BML	BL	BL	BM	B
0010	2	POF	-	SZB 2	-	-	TAX	A 2	LA 2	TABP 2	TABP 18	TABP 34	TABP 50*	BML	BML	BL	BL	BM	B
0011	3	SNZP	INY	SZB 3	-	-	TAZ	A 3	LA 3	TABP 3	TABP 19	TABP 35	TABP 51*	BML	BML	BL	BL	BM	B
0100	4	DI	RD	SZD	-	RT	TAV1	A 4	LA 4	TABP 4	TABP 20	TABP 36	TABP 52*	BML	BML	BL	BL	BM	B
0101	5	EI	SD	SEAn	-	RTS	TAV2	A 5	LA 5	TABP 5	TABP 21	TABP 37	TABP 53*	BML	BML	BL	BL	BM	B
0110	6	RC	-	SEAM	-	RTI	-	A 6	LA 6	TABP 6	TABP 22	TABP 38	TABP 54*	BML	BML	BL	BL	BM	B
0111	7	SC	DEY	-	-	-	-	A 7	LA 7	TABP 7	TABP 23	TABP 39	TABP 55*	BML	BML	BL	BL	BM	B
1000	8	-	AND	-	SNZ0	LZ 0	-	A 8	LA 8	TABP 8	TABP 24	TABP 40	TABP 56*	BML	BML	BL	BL	BM	B
1001	9	-	OR	TDA	SNZ1	LZ 1	-	A 9	LA 9	TABP 9	TABP 25	TABP 41	TABP 57*	BML	BML	BL	BL	BM	B
1010	A	AM	TEAB	TABE	SNZI0	LZ 2	-	A 10	LA 10	TABP 10	TABP 26	TABP 42	TABP 58*	BML	BML	BL	BL	BM	B
1011	B	AMC	-	-	SNZI1	LZ 3	EPOF	A 11	LA 11	TABP 11	TABP 27	TABP 43	TABP 59*	BML	BML	BL	BL	BM	B
1100	C	TYA	CMA	-	-	RB 0	SB 0	A 12	LA 12	TABP 12	TABP 28	TABP 44	TABP 60*	BML	BML	BL	BL	BM	B
1101	D	-	RAR	-	-	RB 1	SB 1	A 13	LA 13	TABP 13	TABP 29	TABP 45	TABP 61*	BML	BML	BL	BL	BM	B
1110	E	TBA	TAB	-	TV2A	RB 2	SB 2	A 14	LA 14	TABP 14	TABP 30	TABP 46	TABP 62*	BML	BML	BL	BL	BM	B
1111	F	-	TAY	SZC	TV1A	RB 3	SB 3	A 15	LA 15	TABP 15	TABP 31	TABP 47	TABP 63*	BML	BML	BL	BL	BM	B

The above table shows the relationship between machine language codes and machine language instructions. D3-D0 show the low-order 4 bits of the machine language code, and D9-D4 show the high-order 6 bits of the machine language code. The hexadecimal representation of the code is also provided. There are one-word instructions and two-word instructions, but only the first word of each instruction is shown. Do not use code marked "-."

The codes for the second word of a two-word instruction are described below.

	The second word
BL	10 paaa aaaa
BML	10 paaa aaaa
BLA	10 pp00 pppp
BMLA	10 pp00 pppp
SEA	00 0111 nnnn
SZD	00 0010 1011

* * cannot be used in the M34514M6-XXXFP.

INSTRUCTION CODE TABLE (continued) (for 4514 Group)

D3-D0	Hex. notation	D9-D4	100000	100001	100010	100011	100100	100101	100110	100111	101000	101001	101010	101011	101100	101101	101110	101111	110000 111111
		20	21	22	23	24	25	26	27	28	29	2A	2B	2C	2D	2E	2F	30-3F	
0000	0	-	TW3A	OP0A	T1AB	-	TAW6	IAP0	TAB1	SNZT1	-	WRST	TMA0	TAM0	XAM0	XAMI0	XAMD0	LXY	
0001	1	-	TW4A	OP1A	T2AB	-	-	IAP1	TAB2	SNZT2	-	-	TMA1	TAM1	XAM1	XAMI1	XAMD1	LXY	
0010	2	TJ1A	-	-	T3AB	TAJ1	TAMR	IAP2	TAB3	SNZT3	-	-	TMA2	TAM2	XAM2	XAMI2	XAMD2	LXY	
0011	3	-	TW6A	OP3A	T4AB	-	TAI1	IAP3	TAB4	SNZT4	-	-	TMA3	TAM3	XAM3	XAMI3	XAMD3	LXY	
0100	4	TQ1A	-	OP4A	-	TAQ1	TAI2	IAP4	-	-	-	-	TMA4	TAM4	XAM4	XAMI4	XAMD4	LXY	
0101	5	TQ2A	-	OP5A	-	TAQ2	-	IAP5	-	-	-	-	TMA5	TAM5	XAM5	XAMI5	XAMD5	LXY	
0110	6	TQ3A	TMRA	-	-	TAQ3	TAK0	-	-	-	-	-	TMA6	TAM6	XAM6	XAMI6	XAMD6	LXY	
0111	7	-	TI1A	-	-	-	TAPU0	-	-	SNZAD	-	-	TMA7	TAM7	XAM7	XAMI7	XAMD7	LXY	
1000	8	-	TI2A	TFR0A	TSIAB	-	-	-	TABS1	SNZSI	-	-	TMA8	TAM8	XAM8	XAMI8	XAMD8	LXY	
1001	9	-	-	-	TADAB	TALA	-	-	TABAD	-	-	-	TMA9	TAM9	XAM9	XAMI9	XAMD9	LXY	
1010	A	-	-	-	-	-	-	-	-	-	-	-	TMA10	TAM10	XAM10	XAMI10	XAMD10	LXY	
1011	B	-	TK0A	-	TR3AB	TAW1	-	-	-	-	-	-	TMA11	TAM11	XAM11	XAMI11	XAMD11	LXY	
1100	C	-	-	-	-	TAW2	-	-	-	-	-	-	TMA12	TAM12	XAM12	XAMI12	XAMD12	LXY	
1101	D	-	-	TPU0A	-	TAW3	-	-	-	-	-	-	TMA13	TAM13	XAM13	XAMI13	XAMD13	LXY	
1110	E	TW1A	-	-	-	TAW4	-	-	-	-	SST	-	TMA14	TAM14	XAM14	XAMI14	XAMD14	LXY	
1111	F	TW2A	-	-	TR1AB	-	-	-	-	-	ADST	-	TMA15	TAM15	XAM15	XAMI15	XAMD15	LXY	

The above table shows the relationship between machine language codes and machine language instructions. D3-D0 show the low-order 4 bits of the machine language code, and D9-D4 show the high-order 6 bits of the machine language code. The hexadecimal representation of the code is also provided. There are one-word instructions and two-word instructions, but only the first word of each instruction is shown. Do not use code marked “-.”

The codes for the second word of a two-word instruction are described below.

	The second word
BL	10 paaa aaaa
BML	10 paaa aaaa
BLA	10 pp00 pppp
BMLA	10 pp00 pppp
SEA	00 0111 nnnn
SZD	00 0010 1011

HARDWARE

MACHINE INSTRUCTIONS

MACHINE INSTRUCTIONS

Parameter Type of instructions	Mnemonic	Instruction code											Number of words	Number of cycles	Function
		D9	D8	D7	D6	D5	D4	D3	D2	D1	D0	Hexadecimal notation			
Register to register transfer	TAB	0	0	0	0	0	1	1	1	1	0	0 1 E	1	1	(A) ← (B)
	TBA	0	0	0	0	0	0	1	1	1	0	0 0 E	1	1	(B) ← (A)
	TAY	0	0	0	0	0	1	1	1	1	1	0 1 F	1	1	(A) ← (Y)
	TYA	0	0	0	0	0	0	1	1	0	0	0 0 C	1	1	(Y) ← (A)
	TEAB	0	0	0	0	0	1	1	0	1	0	0 1 A	1	1	(E7–E4) ← (B) (E3–E0) ← (A)
	TABE	0	0	0	0	1	0	1	0	1	0	0 2 A	1	1	(B) ← (E7–E4) (A) ← (E3–E0)
	TDA	0	0	0	0	1	0	1	0	0	1	0 2 9	1	1	(DR2–DR0) ← (A2–A0)
	TAD	0	0	0	1	0	1	0	0	0	1	0 5 1	1	1	(A2–A0) ← (DR2–DR0) (A3) ← 0
	TAZ	0	0	0	1	0	1	0	0	1	1	0 5 3	1	1	(A1, A0) ← (Z1, Z0) (A3, A2) ← 0
	TAX	0	0	0	1	0	1	0	0	1	0	0 5 2	1	1	(A) ← (X)
	TASP	0	0	0	1	0	1	0	0	0	0	0 5 0	1	1	(A2–A0) ← (SP2–SP0) (A3) ← 0
RAM addresses	LXY x, y	1	1	x3	x2	x1	x0	y3	y2	y1	y0	3 x y	1	1	(X) ← x, x = 0 to 15 (Y) ← y, y = 0 to 15
	LZ z	0	0	0	1	0	0	1	0	z1	z0	0 4 8 +z	1	1	(Z) ← z, z = 0 to 3
	INY	0	0	0	0	0	1	0	0	1	1	0 1 3	1	1	(Y) ← (Y) + 1
	DEY	0	0	0	0	0	1	0	1	1	1	0 1 7	1	1	(Y) ← (Y) – 1
RAM to register transfer	TAM j	1	0	1	1	0	0	j	j	j	j	2 C j	1	1	(A) ← (M(DP)) (X) ← (X)EXOR(j) j = 0 to 15
	XAM j	1	0	1	1	0	1	j	j	j	j	2 D j	1	1	(A) ← → (M(DP)) (X) ← (X)EXOR(j) j = 0 to 15
	XAMD j	1	0	1	1	1	1	j	j	j	j	2 F j	1	1	(A) ← → (M(DP)) (X) ← (X)EXOR(j) j = 0 to 15 (Y) ← (Y) – 1
	XAMI j	1	0	1	1	1	0	j	j	j	j	2 E j	1	1	(A) ← → (M(DP)) (X) ← (X)EXOR(j) j = 0 to 15 (Y) ← (Y) + 1
	TMA j	1	0	1	0	1	1	j	j	j	j	2 B j	1	1	(M(DP)) ← (A) (X) ← (X)EXOR(j) j = 0 to 15

HARDWARE

MACHINE INSTRUCTIONS

Skip condition	Carry flag CY	Detailed description
–	–	Transfers the contents of register B to register A.
–	–	Transfers the contents of register A to register B.
–	–	Transfers the contents of register Y to register A.
–	–	Transfers the contents of register A to register Y.
–	–	Transfers the contents of registers A and B to register E.
–	–	Transfers the contents of register E to registers A and B.
–	–	Transfers the contents of register A to register D.
–	–	Transfers the contents of register D to register A.
–	–	Transfers the contents of register Z to register A.
–	–	Transfers the contents of register X to register A.
–	–	Transfers the contents of stack pointer (SP) to register A.
Continuous description	–	Loads the value x in the immediate field to register X, and the value y in the immediate field to register Y. When the LXY instructions are continuously coded and executed, only the first LXY instruction is executed and other LXY instructions coded continuously are skipped.
–	–	Loads the value z in the immediate field to register Z.
(Y) = 0	–	Adds 1 to the contents of register Y. As a result of addition, when the contents of register Y is 0, the next instruction is skipped.
(Y) = 15	–	Subtracts 1 from the contents of register Y. As a result of subtraction, when the contents of register Y is 15, the next instruction is skipped.
–	–	After transferring the contents of M(DP) to register A, an exclusive OR operation is performed between register X and the value j in the immediate field, and stores the result in register X.
–	–	After exchanging the contents of M(DP) with the contents of register A, an exclusive OR operation is performed between register X and the value j in the immediate field, and stores the result in register X.
(Y) = 15	–	After exchanging the contents of M(DP) with the contents of register A, an exclusive OR operation is performed between register X and the value j in the immediate field, and stores the result in register X. Subtracts 1 from the contents of register Y. As a result of subtraction, when the contents of register Y is 15, the next instruction is skipped.
(Y) = 0	–	After exchanging the contents of M(DP) with the contents of register A, an exclusive OR operation is performed between register X and the value j in the immediate field, and stores the result in register X. Adds 1 to the contents of register Y. As a result of addition, when the contents of register Y is 0, the next instruction is skipped.
–	–	After transferring the contents of register A to M(DP), an exclusive OR operation is performed between register X and the value j in the immediate field, and stores the result in register X.

HARDWARE

MACHINE INSTRUCTIONS

MACHINE INSTRUCTIONS (continued)

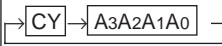
Parameter Type of instructions	Mnemonic	Instruction code											Number of words	Number of cycles	Function
		D9	D8	D7	D6	D5	D4	D3	D2	D1	D0	Hexadecimal notation			
Arithmetic operation	LA n	0	0	0	1	1	1	n	n	n	n	0 7 n	1	1	$(A) \leftarrow n$ $n = 0 \text{ to } 15$
	TABP p	0	0	1	0	p5	p4	p3	p2	p1	p0	0 8 p +p	1	3	$(SP) \leftarrow (SP) + 1$ $(SK(SP)) \leftarrow (PC)$ $(PCH) \leftarrow p$ $(PCL) \leftarrow (DR2-DR0, A3-A0)$ $(B) \leftarrow (ROM(PC))_{7-4}$ $(A) \leftarrow (ROM(PC))_{3-0}$ $(PC) \leftarrow (SK(SP))$ $(SP) \leftarrow (SP) - 1$ (Note)
	AM	0	0	0	0	0	0	1	0	1	0	0 0 A	1	1	$(A) \leftarrow (A) + (M(DP))$
	AMC	0	0	0	0	0	0	1	0	1	1	0 0 B	1	1	$(A) \leftarrow (A) + (M(DP)) + (CY)$ $(CY) \leftarrow \text{Carry}$
	A n	0	0	0	1	1	0	n	n	n	n	0 6 n	1	1	$(A) \leftarrow (A) + n$ $n = 0 \text{ to } 15$
	AND	0	0	0	0	0	1	1	0	0	0	0 1 8	1	1	$(A) \leftarrow (A) \text{ AND } (M(DP))$
	OR	0	0	0	0	0	1	1	0	0	1	0 1 9	1	1	$(A) \leftarrow (A) \text{ OR } (M(DP))$
	SC	0	0	0	0	0	0	0	1	1	1	0 0 7	1	1	$(CY) \leftarrow 1$
	RC	0	0	0	0	0	0	0	1	1	0	0 0 6	1	1	$(CY) \leftarrow 0$
	SZC	0	0	0	0	1	0	1	1	1	1	0 2 F	1	1	$(CY) = 0 ?$
	CMA	0	0	0	0	0	1	1	1	0	0	0 1 C	1	1	$(A) \leftarrow \overline{(A)}$
RAR	0	0	0	0	0	1	1	1	0	1	0 1 D	1	1		
Bit operation	SB j	0	0	0	1	0	1	1	1	j	j	0 5 C +j	1	1	$(M_j(DP)) \leftarrow 1$ $j = 0 \text{ to } 3$
	RB j	0	0	0	1	0	0	1	1	j	j	0 4 C +j	1	1	$(M_j(DP)) \leftarrow 0$ $j = 0 \text{ to } 3$
	SZB j	0	0	0	0	1	0	0	0	j	j	0 2 j	1	1	$(M_j(DP)) = 0 ?$ $j = 0 \text{ to } 3$
Comparison operation	SEAM	0	0	0	0	1	0	0	1	1	0	0 2 6	1	1	$(A) = (M(DP)) ?$
	SEA n	0	0	0	0	1	0	0	1	0	1	0 2 5	2	2	$(A) = n ?$ $n = 0 \text{ to } 15$
		0	0	0	1	1	1	n	n	n	n	0 7 n			

Note : p is 0 to 15 for M34513M2, p is 0 to 31 for M34513M4/E4, p is 0 to 47 for M34513M6 and M34514M6, and p is 0 to 63 for M34513M8/E8 and M34514M8/E8.

Skip condition	Carry flag CY	Detailed description
Continuous description	–	Loads the value n in the immediate field to register A. When the LA instructions are continuously coded and executed, only the first LA instruction is executed and other LA instructions coded continuously are skipped.
–	–	Transfers bits 7 to 4 to register B and bits 3 to 0 to register A. These bits 7 to 0 are the ROM pattern in address (DR2 DR1 DR0 A3 A2 A1 A0) ₂ specified by registers A and D in page p. When this instruction is executed, 1 stage of stack register is used.
–	–	Adds the contents of M(DP) to register A. Stores the result in register A. The contents of carry flag CY remains unchanged.
–	0/1	Adds the contents of M(DP) and carry flag CY to register A. Stores the result in register A and carry flag CY.
Overflow = 0	–	Adds the value n in the immediate field to register A. The contents of carry flag CY remains unchanged. Skips the next instruction when there is no overflow as the result of operation.
–	–	Takes the AND operation between the contents of register A and the contents of M(DP), and stores the result in register A.
–	–	Takes the OR operation between the contents of register A and the contents of M(DP), and stores the result in register A.
–	1	Sets (1) to carry flag CY.
–	0	Clears (0) to carry flag CY.
(CY) = 0	–	Skips the next instruction when the contents of carry flag CY is “0.”
–	–	Stores the one’s complement for register A’s contents in register A.
–	0/1	Rotates 1 bit of the contents of register A including the contents of carry flag CY to the right.
–	–	Sets (1) the contents of bit j (bit specified by the value j in the immediate field) of M(DP).
–	–	Clears (0) the contents of bit j (bit specified by the value j in the immediate field) of M(DP).
(Mj(DP)) = 0 j = 0 to 3	–	Skips the next instruction when the contents of bit j (bit specified by the value j in the immediate field) of M(DP) is “0.”
(A) = (M(DP))	–	Skips the next instruction when the contents of register A is equal to the contents of M(DP).
(A) = n	–	Skips the next instruction when the contents of register A is equal to the value n in the immediate field.

HARDWARE

MACHINE INSTRUCTIONS

MACHINE INSTRUCTIONS (continued)

Parameter Type of instructions	Mnemonic	Instruction code											Number of words	Number of cycles	Function
		D9	D8	D7	D6	D5	D4	D3	D2	D1	D0	Hexadecimal notation			
Branch operation	B a	0	1	1	a6	a5	a4	a3	a2	a1	a0	1 8 a +a	1	1	(PCL) ← a6–a0
	BL p, a	0	0	1	1	1	p4	p3	p2	p1	p0	0 E p +p	2	2	(PCH) ← p (PCL) ← a6–a0 (Note)
		1	0	p5	a6	a5	a4	a3	a2	a1	a0	2 p a +a			
	BLA p	0	0	0	0	0	1	0	0	0	0	0 1 0	2	2	(PCH) ← p (PCL) ← (DR2–DR0, A3–A0) (Note)
1		0	p5	p4	0	0	p3	p2	p1	p0	2 p p				
Subroutine operation	BM a	0	1	0	a6	a5	a4	a3	a2	a1	a0	1 a a	1	1	(SP) ← (SP) + 1 (SK(SP)) ← (PC) (PCH) ← 2 (PCL) ← a6–a0
	BML p, a	0	0	1	1	0	p4	p3	p2	p1	p0	0 C p +p	2	2	(SP) ← (SP) + 1 (SK(SP)) ← (PC) (PCH) ← p (PCL) ← a6–a0 (Note)
		1	0	p5	a6	a5	a4	a3	a2	a1	a0	2 p a +a			
	BMLA p	0	0	0	0	1	1	0	0	0	0	0 3 0	2	2	(SP) ← (SP) + 1 (SK(SP)) ← (PC) (PCH) ← p (PCL) ← (DR2–DR0, A3–A0) (Note)
1		0	p5	p4	0	0	p3	p2	p1	p0	2 p p				
Return operation	RTI	0	0	0	1	0	0	0	1	1	0	0 4 6	1	1	(PC) ← (SK(SP)) (SP) ← (SP) – 1
	RT	0	0	0	1	0	0	0	1	0	0	0 4 4	1	2	(PC) ← (SK(SP)) (SP) ← (SP) – 1
	RTS	0	0	0	1	0	0	0	1	0	1	0 4 5	1	2	(PC) ← (SK(SP)) (SP) ← (SP) – 1
Interrupt operation	DI	0	0	0	0	0	0	0	1	0	0	0 0 4	1	1	(INTE) ← 0
	EI	0	0	0	0	0	0	0	1	0	1	0 0 5	1	1	(INTE) ← 1
	SNZ0	0	0	0	0	1	1	1	0	0	0	0 3 8	1	1	(EXF0) = 1 ? After skipping (EXF0) ← 0
	SNZ1	0	0	0	0	1	1	1	0	0	1	0 3 9	1	1	(EXF1) = 1 ? After skipping (EXF1) ← 0

Note : p is 0 to 15 for M34513M2, p is 0 to 31 for M34513M4/E4, p is 0 to 47 for M34513M6 and M34514M6, and p is 0 to 63 for M34513M8/E8 and M34514M8/E8.

HARDWARE

MACHINE INSTRUCTIONS

Skip condition	Carry flag CY	Detailed description
–	–	Branch within a page : Branches to address a in the identical page.
–	–	Branch out of a page : Branches to address a in page p.
–	–	Branch out of a page : Branches to address (DR2 DR1 DR0 A3 A2 A1 A0) ₂ specified by registers D and A in page p.
–	–	Call the subroutine in page 2 : Calls the subroutine at address a in page 2.
–	–	Call the subroutine : Calls the subroutine at address a in page p.
–	–	Call the subroutine : Calls the subroutine at address (DR2 DR1 DR0 A3 A2 A1 A0) ₂ specified by registers D and A in page p.
–	–	Returns from interrupt service routine to main routine. Returns each value of data pointer (X, Y, Z), carry flag, skip status, NOP mode status by the continuous description of the LA/LXY instruction, register A and register B to the states just before interrupt.
–	–	Returns from subroutine to the routine called the subroutine.
Skip at uncondition	–	Returns from subroutine to the routine called the subroutine, and skips the next instruction at uncondition.
–	–	Clears (0) to the interrupt enable flag INTE, and disables the interrupt.
–	–	Sets (1) to the interrupt enable flag INTE, and enables the interrupt.
(EXF0) = 1	–	Skips the next instruction when the contents of EXF0 flag is “1.” After skipping, clears (0) to the EXF0 flag.
(EXF1) = 1	–	Skips the next instruction when the contents of EXF1 flag is “1.” After skipping, clears (0) to the EXF1 flag.

HARDWARE

MACHINE INSTRUCTIONS

MACHINE INSTRUCTIONS (continued)

Parameter Type of instructions	Mnemonic	Instruction code										Hexadecimal notation	Number of words	Number of cycles	Function
		D9	D8	D7	D6	D5	D4	D3	D2	D1	D0				
Interrupt operation	SNZI0	0	0	0	0	1	1	1	0	1	0	0 3 A	1	1	I12 = 1 : (INT0) = "H" ? I12 = 0 : (INT0) = "L" ?
	SNZI1	0	0	0	0	1	1	1	0	1	1	0 3 B	1	1	I22 = 1 : (INT1) = "H" ? I22 = 0 : (INT1) = "L" ?
	TAV1	0	0	0	1	0	1	0	1	0	0	0 5 4	1	1	(A) ← (V1)
	TV1A	0	0	0	0	1	1	1	1	1	1	0 3 F	1	1	(V1) ← (A)
	TAV2	0	0	0	1	0	1	0	1	0	1	0 5 5	1	1	(A) ← (V2)
	TV2A	0	0	0	0	1	1	1	1	1	0	0 3 E	1	1	(V2) ← (A)
	TAI1	1	0	0	1	0	1	0	0	1	1	2 5 3	1	1	(A) ← (I1)
	TI1A	1	0	0	0	0	1	0	1	1	1	2 1 7	1	1	(I1) ← (A)
	TAI2	1	0	0	1	0	1	0	1	0	0	2 5 4	1	1	(A) ← (I2)
TI2A	1	0	0	0	0	1	1	0	0	0	2 1 8	1	1	(I2) ← (A)	
Timer operation	TAW1	1	0	0	1	0	0	1	0	1	1	2 4 B	1	1	(A) ← (W1)
	TW1A	1	0	0	0	0	0	1	1	1	0	2 0 E	1	1	(W1) ← (A)
	TAW2	1	0	0	1	0	0	1	1	0	0	2 4 C	1	1	(A) ← (W2)
	TW2A	1	0	0	0	0	0	1	1	1	1	2 0 F	1	1	(W2) ← (A)
	TAW3	1	0	0	1	0	0	1	1	0	1	2 4 D	1	1	(A) ← (W3)
	TW3A	1	0	0	0	0	1	0	0	0	0	2 1 0	1	1	(W3) ← (A)
	TAW4	1	0	0	1	0	0	1	1	1	0	2 4 E	1	1	(A) ← (W4)
	TW4A	1	0	0	0	0	1	0	0	0	1	2 1 1	1	1	(W4) ← (A)
	TAW6	1	0	0	1	0	1	0	0	0	0	2 5 0	1	1	(A) ← (W6)
	TW6A	1	0	0	0	0	1	0	0	1	1	2 1 3	1	1	(W6) ← (A)

HARDWARE

MACHINE INSTRUCTIONS

Skip condition	Carry flag CY	Detailed description
(INT0) = "H" However, I12 = 1	–	When bit 2 (I12) of register I1 is "1" : Skips the next instruction when the level of INT0 pin is "H."
(INT0) = "L" However, I12 = 0	–	When bit 2 (I12) of register I1 is "0" : Skips the next instruction when the level of INT0 pin is "L."
(INT1) = "H" However, I22 = 1	–	When bit 2 (I22) of register I2 is "1" : Skips the next instruction when the level of INT1 pin is "H."
(INT1) = "L" However, I22 = 0	–	When bit 2 (I22) of register I2 is "0" : Skips the next instruction when the level of INT1 pin is "L."
–	–	Transfers the contents of interrupt control register V1 to register A.
–	–	Transfers the contents of register A to interrupt control register V1.
–	–	Transfers the contents of interrupt control register V2 to register A.
–	–	Transfers the contents of register A to interrupt control register V2.
–	–	Transfers the contents of interrupt control register I1 to register A.
–	–	Transfers the contents of register A to interrupt control register I1.
–	–	Transfers the contents of interrupt control register I2 to register A.
–	–	Transfers the contents of register A to interrupt control register I2.
–	–	Transfers the contents of timer control register W1 to register A.
–	–	Transfers the contents of register A to timer control register W1.
–	–	Transfers the contents of timer control register W2 to register A.
–	–	Transfers the contents of register A to timer control register W2.
–	–	Transfers the contents of timer control register W3 to register A.
–	–	Transfers the contents of register A to timer control register W3.
–	–	Transfers the contents of timer control register W4 to register A.
–	–	Transfers the contents of register A to timer control register W4.
–	–	Transfers the contents of timer control register W6 to register A.
–	–	Transfers the contents of register A to timer control register W6.

HARDWARE

MACHINE INSTRUCTIONS

MACHINE INSTRUCTIONS (continued)

Parameter Type of instructions	Mnemonic	Instruction code											Hexadecimal notation	Number of words	Number of cycles	Function
		D9	D8	D7	D6	D5	D4	D3	D2	D1	D0					
Timer operation	TAB1	1	0	0	1	1	1	0	0	0	0	2 7 0	1	1	(B) ← (T17–T14) (A) ← (T13–T10)	
	T1AB	1	0	0	0	1	1	0	0	0	0	2 3 0	1	1	(R17–R14) ← (B) (T17–T14) ← (B) (R13–R10) ← (A) (T13–T10) ← (A)	
	TAB2	1	0	0	1	1	1	0	0	0	1	2 7 1	1	1	(B) ← (T27–T24) (A) ← (T23–T20)	
	T2AB	1	0	0	0	1	1	0	0	0	1	2 3 1	1	1	(R27–R24) ← (B) (T27–T24) ← (B) (R23–R20) ← (A) (T23–T20) ← (A)	
	TAB3	1	0	0	1	1	1	0	0	1	0	2 7 2	1	1	(B) ← (T37–T34) (A) ← (T33–T30)	
	T3AB	1	0	0	0	1	1	0	0	1	0	2 3 2	1	1	(R37–R34) ← (B) (T37–T34) ← (B) (R33–R30) ← (A) (T33–T30) ← (A)	
	TAB4	1	0	0	1	1	1	0	0	1	1	2 7 3	1	1	(B) ← (T47–T44) (A) ← (T43–T40)	
	T4AB	1	0	0	0	1	1	0	0	1	1	2 3 3	1	1	(R47–R44) ← (B) (T47–T44) ← (B) (R43–R40) ← (A) (T43–T40) ← (A)	
	TR1AB	1	0	0	0	1	1	1	1	1	1	2 3 F	1	1	(R17–R14) ← (B) (R13–R10) ← (A)	
	TR3AB	1	0	0	0	1	1	1	0	1	1	2 3 B	1	1	(R37–R34) ← (B) (R33–R30) ← (A)	
	SNZT1	1	0	1	0	0	0	0	0	0	0	2 8 0	1	1	(T1F) = 1 ? After skipping (T1F) ← 0	
	SNZT2	1	0	1	0	0	0	0	0	0	1	2 8 1	1	1	(T2F) = 1 ? After skipping (T2F) ← 0	
	SNZT3	1	0	1	0	0	0	0	0	1	0	2 8 2	1	1	(T3F) = 1 ? After skipping (T3F) ← 0	
	SNZT4	1	0	1	0	0	0	0	0	1	1	2 8 3	1	1	(T4F) = 1 ? After skipping (T4F) ← 0	

Skip condition	Carry flag CY	Detailed description
-	-	Transfers the contents of timer 1 to registers A and B.
-	-	Transfers the contents of registers A and B to timer 1 and timer 1 reload register.
-	-	Transfers the contents of timer 2 to registers A and B.
-	-	Transfers the contents of registers A and B to timer 2 and timer 2 reload register.
-	-	Transfers the contents of timer 3 to registers A and B.
-	-	Transfers the contents of registers A and B to timer 3 and timer 3 reload register.
-	-	Transfers the contents of timer 4 to registers A and B.
-	-	Transfers the contents of registers A and B to timer 4 and timer 4 reload register.
-	-	Transfers the contents of registers A and B to timer 1 reload register.
-	-	Transfers the contents of registers A and B to timer 3 reload register.
(T1F) = 1	-	Skips the next instruction when the contents of T1F flag is "1." After skipping, clears (0) to T1F flag.
(T2F) = 1	-	Skips the next instruction when the contents of T2F flag is "1." After skipping, clears (0) to T2F flag.
(T3F) = 1	-	Skips the next instruction when the contents of T3F flag is "1." After skipping, clears (0) to T3F flag.
(T4F) = 1	-	Skips the next instruction when the contents of T4F flag is "1." After skipping, clears (0) to T4F flag.

HARDWARE

MACHINE INSTRUCTIONS

MACHINE INSTRUCTIONS (continued)

Parameter Type of instructions	Mnemonic	Instruction code											Number of words	Number of cycles	Function
		D9	D8	D7	D6	D5	D4	D3	D2	D1	D0	Hexadecimal notation			
Input/Output operation	IAP0	1	0	0	1	1	0	0	0	0	0	2 6 0	1	1	(A) ← (P0)
	OP0A	1	0	0	0	1	0	0	0	0	0	2 2 0	1	1	(P0) ← (A)
	IAP1	1	0	0	1	1	0	0	0	0	1	2 6 1	1	1	(A) ← (P1)
	OP1A	1	0	0	0	1	0	0	0	0	1	2 2 1	1	1	(P1) ← (A)
	IAP2	1	0	0	1	1	0	0	0	1	0	2 6 2	1	1	(A ₂ –A ₀) ← (P ₂₂ –P ₂₀) (A ₃) ← 0
	IAP3	1	0	0	1	1	0	0	0	1	1	2 6 3	1	1	(A) ← (P3)
	OP3A	1	0	0	0	1	0	0	0	1	1	2 2 3	1	1	(P3) ← (A)
	IAP4*	1	0	0	1	1	0	0	1	0	0	2 6 4	1	1	(A) ← (P4)
	OP4A*	1	0	0	0	1	0	0	1	0	0	2 2 4	1	1	(P4) ← (A)
	IAP5*	1	0	0	1	1	0	0	1	0	1	2 6 5	1	1	(A) ← (P5)
	OP5A*	1	0	0	0	1	0	0	1	0	1	2 2 5	1	1	(P5) ← (A)
	CLD	0	0	0	0	0	1	0	0	0	1	0 1 1	1	1	(D) ← 1
	RD	0	0	0	0	0	1	0	1	0	0	0 1 4	1	1	(D(Y)) ← 0 (Y) = 0 to 7
	SD	0	0	0	0	0	1	0	1	0	1	0 1 5	1	1	(D(Y)) ← 1 (Y) = 0 to 7
	SZD	0	0	0	0	1	0	0	1	0	0	0 2 4	2	2	(D(Y)) = 0 ? (Y) = 0 to 7
		0	0	0	0	1	0	1	0	1	1	0 2 B			
	TK0A	1	0	0	0	0	1	1	0	1	1	2 1 B	1	1	(K0) ← (A)
	TAK0	1	0	0	1	0	1	0	1	1	0	2 5 6	1	1	(A) ← (K0)
TPU0A	1	0	0	0	1	0	1	1	0	1	2 2 D	1	1	(PU0) ← (A)	
TAPU0	1	0	0	1	0	1	0	1	1	1	2 5 7	1	1	(A) ← (PU0)	
TFR0A*	1	0	0	0	1	0	1	0	0	0	2 2 8	1	1	(FR0) ← (A)	

*: The 4513 Group does not have these instructions.

Skip condition	Carry flag CY	Detailed description
-	-	Transfers the input of port P0 to register A.
-	-	Outputs the contents of register A to port P0.
-	-	Transfers the input of port P1 to register A.
-	-	Outputs the contents of register A to port P1.
-	-	Transfers the input of port P2 to register A.
-	-	Transfers the input of port P3 to register A.
-	-	Outputs the contents of register A to port P3.
-	-	Transfers the input of port P4 to register A.
-	-	Outputs the contents of register A to port P4.
-	-	Transfers the input of port P5 to register A.
-	-	Outputs the contents of register A to port P5.
-	-	Sets (1) to port D.
-	-	Clears (0) to a bit of port D specified by register Y.
(D(Y)) = 0 (Y) = 0 to 7	-	Skips the next instruction when a bit of port D specified by register Y is "0."
-	-	Transfers the contents of register A to key-on wakeup control register K0.
-	-	Transfers the contents of key-on wakeup control register K0 to register A.
-	-	Transfers the contents of register A to pull-up control register PU0.
-	-	Transfers the contents of pull-up control register PU0 to register A.
-	-	Transfers the contents of register A to direction register FR0.

HARDWARE

MACHINE INSTRUCTIONS

MACHINE INSTRUCTIONS (continued)

Parameter Type of instructions	Mnemonic	Instruction code											Number of words	Number of cycles	Function
		D9	D8	D7	D6	D5	D4	D3	D2	D1	D0	Hexadecimal notation			
Serial I/O control operation	TABSI	1	0	0	1	1	1	1	0	0	0	2 7 8	1	1	(A) ← (SI3–SI0) (B) ← (SI7–SI4)
	TSIAB	1	0	0	0	1	1	1	0	0	0	2 3 8	1	1	(SI3–SI0) ← (A) (SI7–SI4) ← (B)
	TAJ1	1	0	0	1	0	0	0	0	1	0	2 4 2	1	1	(A) ← (J1)
	TJ1A	1	0	0	0	0	0	0	0	1	0	2 0 2	1	1	(J1) ← (A)
	SST	1	0	1	0	0	1	1	1	1	0	2 9 E	1	1	(SIOF) ← 0 Serial I/O starting
	SNZSI	1	0	1	0	0	0	1	0	0	0	2 8 8	1	1	(SIOF) = 1 ? After skipping (SIOF) ← 0
A-D conversion operation	TABAD	1	0	0	1	1	1	1	0	0	1	2 7 9	1	1	(A) ← (AD5–AD2) (B) ← (AD9–AD6) However, in the comparator mode, (A) ← (AD3–AD0) (B) ← (AD7–AD4)
	TALA	1	0	0	1	0	0	1	0	0	1	2 4 9	1	1	(A) ← (AD1, AD0, 0, 0)
	TADAB	1	0	0	0	1	1	1	0	0	1	2 3 9	1	1	(AD3–AD0) ← (A) (AD7–AD4) ← (B)
	TAQ1	1	0	0	1	0	0	0	1	0	0	2 4 4	1	1	(A) ← (Q1)
	TQ1A	1	0	0	0	0	0	0	1	0	0	2 0 4	1	1	(Q1) ← (A)
	ADST	1	0	1	0	0	1	1	1	1	1	2 9 F	1	1	(ADF) ← 0 A-D conversion starting
	SNZAD	1	0	1	0	0	0	0	1	1	1	2 8 7	1	1	(ADF) = 1 ? After skipping (ADF) ← 0
	TAQ2	1	0	0	1	0	0	0	1	0	1	2 4 5	1	1	(A) ← (Q2)
	TQ2A	1	0	0	0	0	0	0	1	0	1	2 0 5	1	1	(Q2) ← (A)
Other operation	NOP	0	0	0	0	0	0	0	0	0	0	0 0 0	1	1	(PC) ← (PC) + 1
	POF	0	0	0	0	0	0	0	0	1	0	0 0 2	1	1	RAM back-up
	EPOF	0	0	0	1	0	1	1	0	1	1	0 5 B	1	1	POF instruction valid
	SNZP	0	0	0	0	0	0	0	0	1	1	0 0 3	1	1	(P) = 1 ?
	WRST	1	0	1	0	1	0	0	0	0	0	2 A 0	1	1	(WDF1) ← 0 (WEF) ← 1
	TAMR	1	0	0	1	0	1	0	0	1	0	2 5 2	1	1	(A) ← (MR)
	TMRA	1	0	0	0	0	1	0	1	1	0	2 1 6	1	1	(MR) ← (A)
	TAQ3	1	0	0	1	0	0	0	1	1	0	2 4 6	1	1	(A) ← (Q3)
	TQ3A	1	0	0	0	0	0	0	1	1	0	2 0 6	1	1	(Q33, Q32) ← (A3, A2) (Q31) ← (CMP1 comparison result) (Q30) ← (CMP0 comparison result)

HARDWARE

MACHINE INSTRUCTIONS

Skip condition	Carry flag CY	Detailed description
<ul style="list-style-type: none"> <li style="margin-bottom: 5px;">– <li style="margin-bottom: 5px;">– <li style="margin-bottom: 5px;">– <li style="margin-bottom: 5px;">– <li style="margin-bottom: 5px;">– <li style="margin-bottom: 5px;">– <p>(SIOF) = 1</p>	<ul style="list-style-type: none"> <li style="margin-bottom: 5px;">– <li style="margin-bottom: 5px;">– <li style="margin-bottom: 5px;">– <li style="margin-bottom: 5px;">– <li style="margin-bottom: 5px;">– <li style="margin-bottom: 5px;">– 	<ul style="list-style-type: none"> <li style="margin-bottom: 5px;">Transfers the contents of serial I/O register SI to registers A and B. <li style="margin-bottom: 5px;">Transfers the contents of registers A and B to serial I/O register SI. <li style="margin-bottom: 5px;">Transfers the contents of serial I/O mode register J1 to register A. <li style="margin-bottom: 5px;">Transfers the contents of register A to serial I/O mode register J1. <li style="margin-bottom: 5px;">Clears (0) to SIOF flag and starts serial I/O. <li style="margin-bottom: 5px;">Skips the next instruction when the contents of SIOF flag is "1." After skipping, clears (0) to SIOF flag.
<ul style="list-style-type: none"> <li style="margin-bottom: 5px;">– <li style="margin-bottom: 5px;">– <li style="margin-bottom: 5px;">– <li style="margin-bottom: 5px;">– <li style="margin-bottom: 5px;">– <li style="margin-bottom: 5px;">– <li style="margin-bottom: 5px;">– <li style="margin-bottom: 5px;">– <p>(ADF) = 1</p>	<ul style="list-style-type: none"> <li style="margin-bottom: 5px;">– <li style="margin-bottom: 5px;">– <li style="margin-bottom: 5px;">– <li style="margin-bottom: 5px;">– <li style="margin-bottom: 5px;">– <li style="margin-bottom: 5px;">– <li style="margin-bottom: 5px;">– <li style="margin-bottom: 5px;">– 	<ul style="list-style-type: none"> <li style="margin-bottom: 5px;">Transfers the high-order 8 bits of the contents of register AD to registers A and B. <li style="margin-bottom: 5px;">Transfers the low-order 2 bits of the contents of register AD to the high-order 2 bits of the contents of register A. Simultaneously, the low-order 2 bits of the contents of the register A is "0." <li style="margin-bottom: 5px;">Transfers the contents of registers A and B to the comparator register at the comparator mode. <li style="margin-bottom: 5px;">Transfers the contents of the A-D control register Q1 to register A. <li style="margin-bottom: 5px;">Transfers the contents of register A to the A-D control register Q1. <li style="margin-bottom: 5px;">Clears the ADF flag, and the A-D conversion at the A-D conversion mode or the comparator operation at the comparator mode is started. <li style="margin-bottom: 5px;">Skips the next instruction when the contents of ADF flag is "1". After skipping, clears (0) the contents of ADF flag. <li style="margin-bottom: 5px;">Transfers the contents of the A-D control register Q2 to register A. <li style="margin-bottom: 5px;">Transfers the contents of register A to the A-D control register Q2.
<ul style="list-style-type: none"> <li style="margin-bottom: 5px;">– <li style="margin-bottom: 5px;">– <li style="margin-bottom: 5px;">– <li style="margin-bottom: 5px;">– <li style="margin-bottom: 5px;">– <li style="margin-bottom: 5px;">– <li style="margin-bottom: 5px;">– <li style="margin-bottom: 5px;">– <p>(P) = 1</p>	<ul style="list-style-type: none"> <li style="margin-bottom: 5px;">– <li style="margin-bottom: 5px;">– <li style="margin-bottom: 5px;">– <li style="margin-bottom: 5px;">– <li style="margin-bottom: 5px;">– <li style="margin-bottom: 5px;">– <li style="margin-bottom: 5px;">– <li style="margin-bottom: 5px;">– 	<ul style="list-style-type: none"> <li style="margin-bottom: 5px;">No operation <li style="margin-bottom: 5px;">Puts the system in RAM back-up state by executing the POF instruction after executing the EPOF instruction. <li style="margin-bottom: 5px;">Makes the immediate POF instruction valid by executing the EPOF instruction. <li style="margin-bottom: 5px;">Skips the next instruction when P flag is "1". After skipping, P flag remains unchanged. <li style="margin-bottom: 5px;">Operates the watchdog timer and initializes the watchdog timer flag WDF1. <li style="margin-bottom: 5px;">Transfers the contents of the clock control register MR to register A. <li style="margin-bottom: 5px;">Transfers the contents of register A to the clock control register MR. <li style="margin-bottom: 5px;">Transfers the contents of the voltage comparator control register Q3 to register A. <li style="margin-bottom: 5px;">Transfers the contents of the high-order 2 bits of register A to the high-order 2 bits of voltage comparator control register Q3, and the comparison result of the voltage comparator is transferred to the low-order 2 bits of the register Q3.

HARDWARE

CONTROL REGISTERS

CONTROL REGISTERS

Interrupt control register V1		at reset : 0000z		at RAM back-up : 0000z		R/W
V13	Timer 2 interrupt enable bit	0	Interrupt disabled (SNZT2 instruction is valid)			
		1	Interrupt enabled (SNZT2 instruction is invalid)			
V12	Timer 1 interrupt enable bit	0	Interrupt disabled (SNZT1 instruction is valid)			
		1	Interrupt enabled (SNZT1 instruction is invalid)			
V11	External 1 interrupt enable bit	0	Interrupt disabled (SNZ1 instruction is valid)			
		1	Interrupt enabled (SNZ1 instruction is invalid)			
V10	External 0 interrupt enable bit	0	Interrupt disabled (SNZ0 instruction is valid)			
		1	Interrupt enabled (SNZ0 instruction is invalid)			
Interrupt control register V2		at reset : 0000z		at RAM back-up : 0000z		R/W
V23	Serial I/O interrupt enable bit	0	Interrupt disabled (SNZSI instruction is valid)			
		1	Interrupt enabled (SNZSI instruction is invalid)			
V22	A-D interrupt enable bit	0	Interrupt disabled (SNZAD instruction is valid)			
		1	Interrupt enabled (SNZAD instruction is invalid)			
V21	Timer 4 interrupt enable bit	0	Interrupt disabled (SNZT4 instruction is valid)			
		1	Interrupt enabled (SNZT4 instruction is invalid)			
V20	Timer 3 interrupt enable bit	0	Interrupt disabled (SNZT3 instruction is valid)			
		1	Interrupt enabled (SNZT3 instruction is invalid)			
Interrupt control register I1		at reset : 0000z		at RAM back-up : state retained		R/W
I13	Not used	0	This bit has no function, but read/write is enabled.			
		1				
I12	Interrupt valid waveform for INT0 pin/ return level selection bit (Note 2)	0	Falling waveform ("L" level of INT0 pin is recognized with the SNZI0 instruction)/"L" level			
		1	Rising waveform ("H" level of INT0 pin is recognized with the SNZI0 instruction)/"H" level			
I11	INT0 pin edge detection circuit control bit	0	One-sided edge detected			
		1	Both edges detected			
I10	INT0 pin timer 1 control enable bit	0	Disabled			
		1	Enabled			
Interrupt control register I2		at reset : 0000z		at RAM back-up : state retained		R/W
I23	Not used	0	This bit has no function, but read/write is enabled.			
		1				
I22	Interrupt valid waveform for INT1 pin/ return level selection bit (Note 3)	0	Falling waveform ("L" level of INT1 pin is recognized with the SNZI1 instruction)/"L" level			
		1	Rising waveform ("H" level of INT1 pin is recognized with the SNZI1 instruction)/"H" level			
I21	INT1 pin edge detection circuit control bit	0	One-sided edge detected			
		1	Both edges detected			
I20	INT1 pin timer 3 control enable bit	0	Disabled			
		1	Enabled			

Notes 1: "R" represents read enabled, and "W" represents write enabled.

2: When the contents of I12 is changed, the external interrupt request flag EXF0 may be set. Accordingly, clear EXF0 flag with the SNZ0 instruction.

3: When the contents of I22 is changed, the external interrupt request flag EXF1 may be set. Accordingly, clear EXF1 flag with the SNZ1 instruction.

HARDWARE

CONTROL REGISTERS

Timer control register W1		at reset : 00002		at RAM back-up : 00002		R/W
W13	Prescaler control bit	0	Stop (state initialized)			
		1	Operating			
W12	Prescaler dividing ratio selection bit	0	Instruction clock divided by 4			
		1	Instruction clock divided by 16			
W11	Timer 1 control bit	0	Stop (state retained)			
		1	Operating			
W10	Timer 1 count start synchronous circuit control bit	0	Count start synchronous circuit not selected			
		1	Count start synchronous circuit selected			
Timer control register W2		at reset : 00002		at RAM back-up : state retained		R/W
W23	Timer 2 control bit	0	Stop (state retained)			
		1	Operating			
W22	Not used	0	This bit has no function, but read/write is enabled.			
		1				
W21	Timer 2 count source selection bits	W21	W20	Count source		
		0	0	Timer 1 underflow signal		
W20	Timer 2 count source selection bits	0	1	Prescaler output		
		1	0	CNTR0 input		
		1	1	16 bit timer (WDT) underflow signal		
Timer control register W3		at reset : 00002		at RAM back-up : state retained		R/W
W33	Timer 3 control bit	0	Stop (state retained)			
		1	Operating			
W32	Timer 3 count start synchronous circuit control bit	0	Count start synchronous circuit not selected			
		1	Count start synchronous circuit selected			
W31	Timer 3 count source selection bits	W31	W30	Count source		
		0	0	Timer 2 underflow signal		
W30	Timer 3 count source selection bits	0	1	Prescaler output		
		1	0	Not available		
		1	1	Not available		
Timer control register W4		at reset : 00002		at RAM back-up : state retained		R/W
W43	Timer 4 control bit	0	Stop (state retained)			
		1	Operating			
W42	Not used	0	This bit has no function, but read/write is enabled.			
		1				
W41	Timer 4 count source selection bits	W41	W40	Count source		
		0	0	Timer 3 underflow signal		
W40	Timer 4 count source selection bits	0	1	Prescaler output		
		1	0	CNTR1 input		
		1	1	Not available		
Timer control register W6		at reset : 00002		at RAM back-up : state retained		R/W
W63	CNTR1 output control bit	0	Timer 3 underflow signal output divided by 2			
		1	CNTR1 output control by timer 4 underflow signal divided by 2			
W62	D7/CNTR1 function selection bit	0	D7(I/O)/CNTR1 input			
		1	CNTR1 (I/O)/D7(input)			
W61	CNTR0 output control bit	0	Timer 1 underflow signal output divided by 2			
		1	CNTR0 output control by timer 2 underflow signal divided by 2			
W60	D6/CNTR0 output control bit	0	D6(I/O)/CNTR0 input			
		1	CNTR0 (I/O)/D6(input)			

Note: "R" represents read enabled, and "W" represents write enabled.

HARDWARE

CONTROL REGISTERS

Serial I/O mode register J1		at reset : 00002		at RAM back-up : state retained	R/W
J13	Not used	0	This bit has no function, but read/write is enabled.		
		1			
J12	Serial I/O internal clock dividing ratio selection bit	0	Instruction clock signal divided by 8		
		1	Instruction clock signal divided by 4		
J11	Serial I/O port selection bit	0	Input ports P20, P21, P22 selected		
		1	Serial I/O ports SCK, SOUT, SIN/input ports P20, P21, P22 selected		
J10	Serial I/O synchronous clock selection bit	0	External clock		
		1	Internal clock (instruction clock divided by 4 or 8)		
A-D control register Q1		at reset : 00002		at RAM back-up : state retained	R/W
Q13	Note used	0	This bit has no function, but read/write is enabled.		
		1			
Q12	Analog input pin selection bits (Note 2)	Q12	Q11	Q10	Selected pins
		0	0	0	AIN0
0		0	1	AIN1	
Q11		0	1	0	AIN2
		0	1	1	AIN3
Q10		1	0	0	AIN4 (Not available for the 4513 Group)
		1	0	1	AIN5 (Not available for the 4513 Group)
		1	1	0	AIN6 (Not available for the 4513 Group)
		1	1	1	AIN7 (Not available for the 4513 Group)
A-D control register Q2		at reset : 00002		at RAM back-up : state retained	R/W
Q23	A-D operation mode selection bit	0	A-D conversion mode		
		1	Comparator mode		
Q22	P43/AIN7 and P42/AIN6 pin function selection bit (Not used for the 4513 Group)	0	P43, P42 (read/write enabled for the 4513 Group)		
		1	AIN7, AIN6/P43, P42 (read/write enabled for the 4513 Group)		
Q21	P41/AIN5 pin function selection bit (Not used for the 4513 Group)	0	P41 (read/write enabled for the 4513 Group)		
		1	AIN5/P41 (read/write enabled for the 4513 Group)		
Q20	P40/AIN4 pin function selection bit (Not used for the 4513 Group)	0	P40 (read/write enabled for the 4513 Group)		
		1	AIN4/P40 (read/write enabled for the 4513 Group)		
Comparator control register Q3 (Note 3)		at reset : 00002		at RAM back-up : state retained	R/W
Q33	Voltage comparator (CMP1) control bit	0	Voltage comparator (CMP1) invalid		
		1	Voltage comparator (CMP1) valid		
Q32	Voltage comparator (CMP0) control bit	0	Voltage comparator (CMP0) invalid		
		1	Voltage comparator (CMP0) valid		
Q31	CMP1 comparison result store bit	0	CMP1- > CMP1+		
		1	CMP1- < CMP1+		
Q30	CMP0 comparison result store bit	0	CMP0- > CMP0+		
		1	CMP0- < CMP0+		
Clock control register MR		at reset : 10002		at RAM back-up : 10002	R/W
MR3	System clock selection bit	0	f(XIN) (high-speed mode)		
		1	f(XIN)/2 (middle-speed mode)		
MR2	Not used	0	This bit has no function, but read/write is enabled.		
		1			
MR1	Not used	0	This bit has no function, but read/write is enabled.		
		1			
MR0	Not used	0	This bit has no function, but read/write is enabled.		
		1			

Notes 1: "R" represents read enabled, "W" represents write enabled.

2: Select AIN4–AIN7 with register Q1 after setting register Q2.

3: Bits 0 and 1 of register Q3 can be only read.

HARDWARE

CONTROL REGISTERS

Key-on wakeup control register K0		at reset : 00002		at RAM back-up : state retained	R/W
K03	Pins P12 and P13 key-on wakeup control bit	0	Key-on wakeup not used		
		1	Key-on wakeup used		
K02	Pins P10 and P11 key-on wakeup control bit	0	Key-on wakeup not used		
		1	Key-on wakeup used		
K01	Pins P02 and P03 key-on wakeup control bit	0	Key-on wakeup not used		
		1	Key-on wakeup used		
K00	Pins P00 and P01 key-on wakeup control bit	0	Key-on wakeup not used		
		1	Key-on wakeup used		
Pull-up control register PU0		at reset : 00002		at RAM back-up : state retained	R/W
PU03	Pins P12 and P13 pull-up transistor control bit	0	Pull-up transistor OFF		
		1	Pull-up transistor ON		
PU02	Pins P10 and P11 pull-up transistor control bit	0	Pull-up transistor OFF		
		1	Pull-up transistor ON		
PU01	Pins P02 and P03 pull-up transistor control bit	0	Pull-up transistor OFF		
		1	Pull-up transistor ON		
PU00	Pins P00 and P01 pull-up transistor control bit	0	Pull-up transistor OFF		
		1	Pull-up transistor ON		
Direction register FR0 (Note 2)		at reset : 00002		at RAM back-up : state retained	W
FR03	Port P53 input/output control bit	0	Port P53 input		
		1	Port P53 output		
FR02	Port P52 input/output control bit	0	Port P52 input		
		1	Port P52 output		
FR01	Port P51 input/output control bit	0	Port P51 input		
		1	Port P51 output		
FR00	Port P50 input/output control bit	0	Port P50 input		
		1	Port P50 output		

Notes 1: "R" represents read enabled, and "W" represents write enabled.

2: The 4513 Group does not have the direction register FR0.

HARDWARE

BUILT-IN PROM VERSION

BUILT-IN PROM VERSION

In addition to the mask ROM versions, the 4513/4514 Group has programmable ROM version software compatible with mask ROM. The built-in PROM of One Time PROM version can be written to and not be erased.

The built-in PROM versions have functions similar to those of the mask ROM versions, but they have PROM mode that enables writing to built-in PROM.

Table 25 shows the product of built-in PROM version. Figure 49 and 50 show the pin configurations of built-in PROM versions.

Table 25 Product of built-in PROM version

Product	PROM size (X 10 bits)	RAM size (X 4 bits)	Package	ROM type
M34513E4SP/FP	4096 words	256 words	SP: 32P4B FP: 32P6B-A	One Time PROM version [shipped in blank]
M34513E8FP	8192 words	384 words	32P6B-A	
M34514E8FP	8192 words	384 words	42P2R-A	

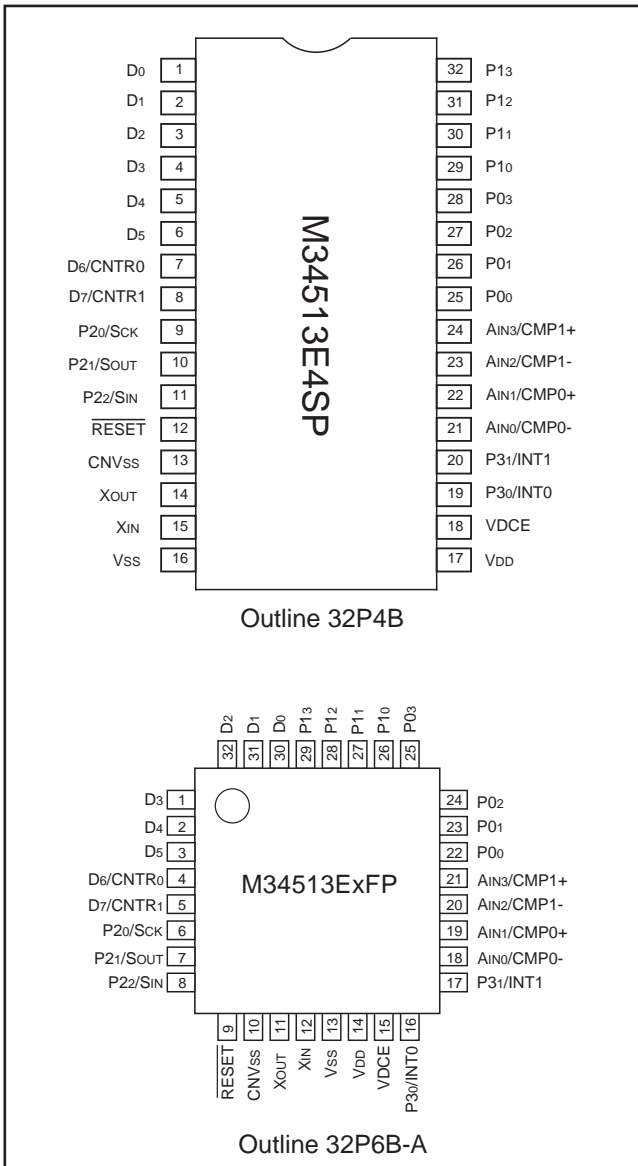

Fig. 49 Pin configuration of built-in PROM version of 4513 Group

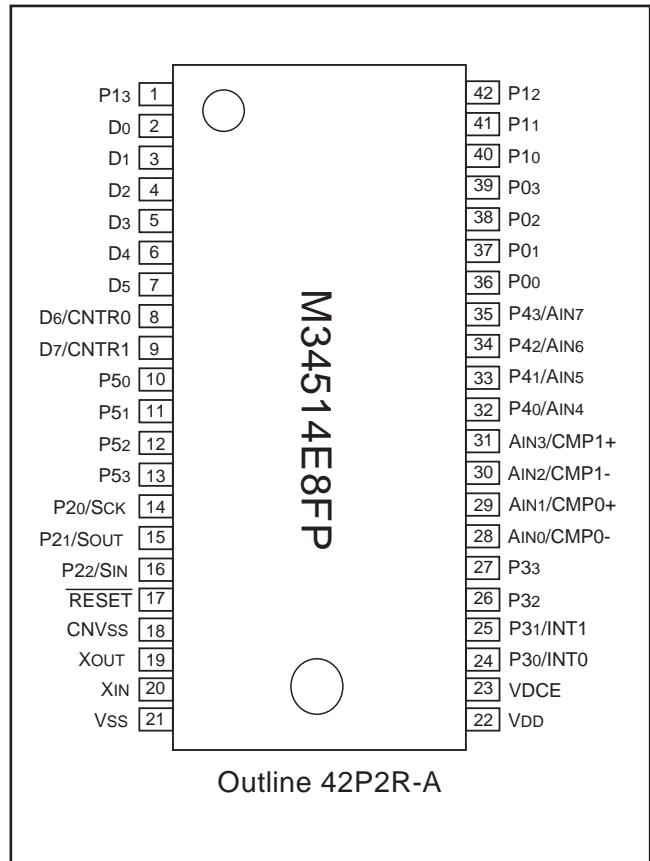

Fig. 50 Pin configuration of built-in PROM version of 4514 Group

(1) PROM mode

The built-in PROM version has a PROM mode in addition to a normal operation mode. The PROM mode is used to write to and read from the built-in PROM.

In the PROM mode, the programming adapter can be used with a general-purpose PROM programmer to write to or read from the built-in PROM as if it were M5M27C256K. Programming adapters are listed in Table 26. Contact addresses at the end of this sheet for the appropriate PROM programmer.

- Writing and reading of built-in PROM

Programming voltage is 12.5 V. Write the program in the PROM of the built-in PROM version as shown in Figure 51.

(2) Notes on handling

- ① A high-voltage is used for writing. Take care that overvoltage is not applied. Take care especially at turning on the power.
- ② For the One Time PROM version shipped in blank, Mitsubishi Electric corp. does not perform PROM writing test and screening in the assembly process and following processes. In order to improve reliability after writing, performing writing and test according to the flow shown in Figure 52 before using is recommended (Products shipped in blank: PROM contents is not written in factory when shipped).

Table 26 Programming adapters

Microcomputer	Programming adapter
M34513E4SP	PCA7442SP
M34513E4FP, M34513E8FP	PCA7442FP
M34514E8FP	PCA7441

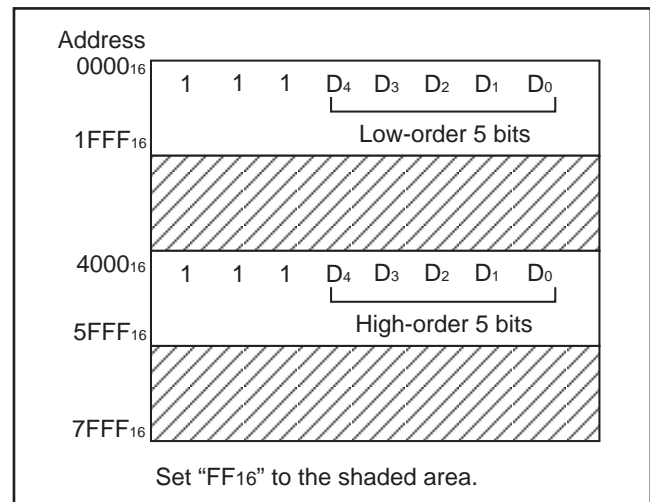

Fig. 51 PROM memory map

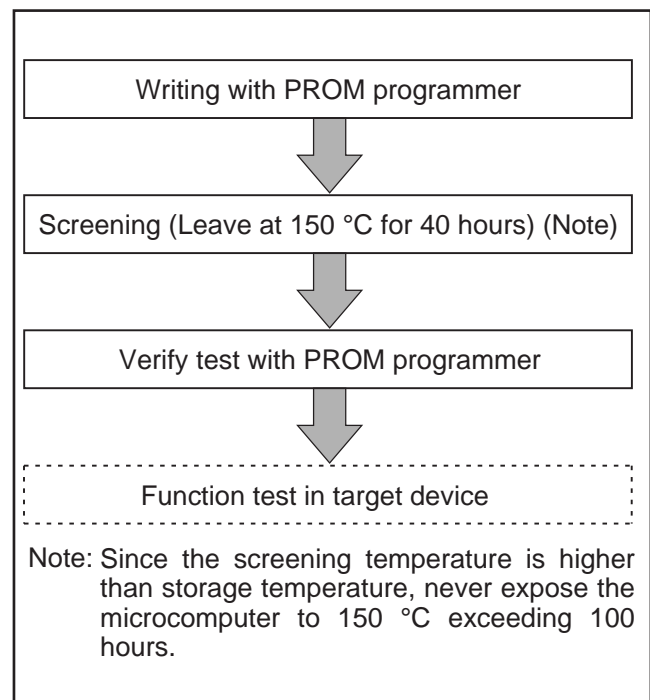

Fig. 52 Flow of writing and test of the product shipped in blank

HARDWARE

BUILT-IN PROM VERSION



CHAPTER 2

APPLICATION

- 2.1 I/O pins
- 2.2 Interrupts
- 2.3 Timers
- 2.4 Serial I/O
- 2.5 A-D converter
- 2.6 Voltage comparator
- 2.7 Reset
- 2.8 Voltage drop detection circuit
- 2.9 RAM back-up
- 2.10 Oscillation circuit

APPLICATION

2.1 I/O pins

2.1 I/O pins

The 4513/4514 Group has the twenty-eight I/O pins (eighteen I/O pins for 4513 Group), three input pins. (Ports P20–P22, P30, P31, D6 and D7 are also used as serial I/O pins SCK, SOUT, SIN, and INT0, INT1, CNTR0 and CNTR1 pins, respectively).

This section describes each port I/O function, related registers, application example using each port function and notes.

2.1.1 I/O ports

(1) Port P0

Port P0 is a 4-bit I/O port.

Port P0 has the key-on wakeup function which turns ON/OFF with register K0 and pull-up transistor which turns ON/OFF with register PU0.

■ Input/output of port P0

● Data input to port P0

Set the output latch of specified port P0i (i=0 to 3) to “1” with the **OP0A** instruction. If the output latch is set to “0,” “L” level is input.

The state of port P0 is transferred to register A when the **IAP0** instruction is executed.

● Data output from port P0

The contents of register A is output to port P0 with the **OP0A** instruction.

The output structure is an N-channel open-drain.

(2) Port P1

Port P1 is a 4-bit I/O port.

Port P1 has the key-on wakeup function which turns ON/OFF with register K0 and pull-up transistor which turns ON/OFF with register PU0.

■ Input/output of port P1

● Data input to port P1

Set the output latch of specified port P1i (i=0 to 3) to “1” with the **OP1A** instruction. If the output latch is set to “0,” “L” level is input.

The state of port P1 is transferred to register A when the **IAP1** instruction is executed.

● Data output from port P1

The contents of register A is output to port P1 with the **OP1A** instruction.

The output structure is an N-channel open-drain.

(3) Port P2

Port P2 is a 3-bit input port.

■ Input of port P2

● Data input to port P2

The state of port P2 is transferred to register A when the **IAP2** instruction is executed. However, port P2 is 3 bits and A3 is fixed to “0.”

(4) Port P3

Port P3 is a 4-bit I/O port for the 4514 Group, and a 2-bit I/O port for the 4513 Group.

■ Input/output of port P3

● Data input to port P3

Set the output latch of specified port P3i (i=0 to 3) to "1" with the **OP3A** instruction. If the output latch is set to "0," "L" level is input.

The state of port P3 is transferred to register A when the **IAP3** instruction is executed. However, A2 and A3 are undefined in the 4513 Group.

● Data output from port P3

The contents of register A is output to port P3 with the **OP3A** instruction.

The output structure is an N-channel open-drain.

(5) Port P4 (The 4513 Group does not have this port.)

Port P4 is a 4-bit I/O port.

■ Input/output of port P4

Ports P40–P43 are also used as AIN4–AIN7. Therefore, when P40/AIN4–P43/AIN7 are used as port P4, set corresponding bits of A-D control register Q2 to "0".

● Data input to port P4

Set the output latch of specified port P4i (i=0 to 3) to "1" with the **OP4A** instruction. If the output latch is set to "0," "L" level is input.

The state of port P4 is transferred to register A when the **IAP4** instruction is executed.

● Data output from port P4

The contents of register A is output to port P4 with the **OP4A** instruction.

The output structure is an N-channel open-drain.

(6) Port P5 (The 4513 Group does not have this port.)

Port P5 is a 4-bit I/O port.

■ Input/output of port P5

Port P5 has direction register FR0 to input/output by the bit.

● Data input to port P5

Set the bit of register FR0i(i=0 to 3) corresponding to specified port P5i (i=0 to 3) to "0." When the register FR0 is set to "1," the value of output latch is input.

The state of port P5 is transferred to register A when the **IAP5** instruction is executed.

● Data output from port P5

Set the bit of register FR0i(i=0 to 3) corresponding to specified port P5i (i=0 to 3) to "1." When the register FR0 is set to "0," specified port P5i is in the high-impedance state.

The contents of register A is output to port P5 with the **OP5A** instruction.

The output structure is CMOS.

APPLICATION

2.1 I/O pins

(7) Port D

D0–D7 are eight independent I/O ports.

■ Input/output of port D

Each pin of port D has an independent 1-bit wide I/O function. For I/O of ports D0–D7, select one of port D with the register Y of the data pointer first.

● Data input to port D

Set the output latch of specified port Di (i = 0 to 7) to “1” with the **SD** instruction.

When the output latch is set to “0,” “L” level is input.

When the **SZD** instruction is executed, if the port specified by register Y is “0,” the next instruction is skipped. If it is “1,” the next instruction is executed.

● Data output from port D

Set the output level to the output latch with the **SD** and **RD** instructions.

The state of pin enters the high-impedance state when the **SD** instruction is executed.

The states of all port D enter the high-impedance state when the **CLD** instruction is executed.

The state of pin becomes “L” level when the **RD** instruction is executed.

The output structure is an N-channel open-drain.

Notes 1: When the **SD** and **RD** instructions are used, do not set “10002” or more to register Y.

2: Port D6 is also used as CNTR0, and port D7 is also used as CNTR1. Accordingly, when using ports D6 and D7 functions, set bit 0 (W60) and bit 2 (W62) of timer control register W6 to “0.”

2.1.2 Related registers

(1) Pull-up control register PU0

Register PU0 controls the ON/OFF of the ports P00–P03 and P10–P13 pull-up transistor.

Set the contents of this register through register A with the **TPU0A** instruction.

The contents of register PU0 is transferred to register A with the **TAPU0** instruction.

Table 2.1.1 shows the pull-up control register PU0.

Table 2.1.1 Pull-up control register PU0

Pull-up control register PU0		at reset : 00002	at RAM back-up : state retained	R/W
PU03	Ports P12, P13 pull-up transistor control bit	0	Pull-up transistor OFF	
		1	Pull-up transistor ON	
PU02	Ports P10, P11 pull-up transistor control bit	0	Pull-up transistor OFF	
		1	Pull-up transistor ON	
PU01	Ports P02, P03 pull-up transistor control bit	0	Pull-up transistor OFF	
		1	Pull-up transistor ON	
PU00	Ports P00, P01 pull-up transistor control bit	0	Pull-up transistor OFF	
		1	Pull-up transistor ON	

Note: “R” represents read enabled, and “W” represents write enabled.

(2) Key-on wakeup control register K0

Register K0 controls the ON/OFF of the key-on wakeup function of ports P00–P03 and P10–P13. Set the contents of this register through register A with the **TK0A** instruction. The contents of register K0 is transferred to register A with the **TAK0** instruction. Table 2.1.2 shows the key-on wakeup control register K0.

Table 2.1.2 Key-on wakeup control register K0

Key-on wakeup control register K0		at reset : 00002	at RAM back-up : state retained	R/W
K03	Ports P12, P13 key-on wakeup control bit	0	Key-on wakeup not used	
		1	Key-on wakeup used	
K02	Ports P10, P11 key-on wakeup control bit	0	Key-on wakeup not used	
		1	Key-on wakeup used	
K01	Ports P02, P03 key-on wakeup control bit	0	Key-on wakeup not used	
		1	Key-on wakeup used	
K00	Ports P00, P01 key-on wakeup control bit	0	Key-on wakeup not used	
		1	Key-on wakeup used	

Note: “R” represents read enabled, and “W” represents write enabled.

(3) A-D control register Q2

Bits 0 to 2 of register Q2 controls the pin function selection bits. Set the contents of this register through register A with the **TQ2A** instruction. The contents of register Q2 is transferred to register A with the **TAQ2** instruction. Table 2.1.3 shows the A-D control register Q2.

Table 2.1.3 A-D control register Q2

A-D control register Q2		at reset : 00002	at RAM back-up : state retained	R/W
Q23	A-D operation mode control bit	0	A-D conversion mode	
		1	Comparator mode	
Q22	P43/AIN7, P42/AIN6 pin function selection bit (Note 3)	0	P43, P42 (I/O) (Note 4)	
		1	AIN7, AIN6/P43, P42 (Output) (Note 4)	
Q21	P41/AIN5 pin function selection bit (Note 3)	0	P41 (I/O) (Note 4)	
		1	AIN5/P41 (Output) (Note 4)	
Q20	P40/AIN4 pin function selection bit (Note 3)	0	P40 (I/O) (Note 4)	
		1	AIN4/P40 (Output) (Note 4)	

Notes 1: “R” represents read enabled, and “W” represents write enabled.

2: Select AIN4–AIN7 with register Q1 after setting register Q2.

3: For the 4513 Group, these bits are not used.

4: For the 4513 Group, only read/write of these bits is enabled.

5: When setting ports, Q23 is not used.

APPLICATION

2.1 I/O pins

(4) Direction register FR0 (The 4513 Group does not have this register.)

Register FR0 is used to switch to input/output of P50–P53.

Set the contents of this register through register A with the **TFR0A** instruction.

Table 2.1.4 shows the direction register FR0.

Table 2.1.4 Direction register FR0

Direction register FR0 (Note 2)		at reset : 00002	at RAM back-up : state retained	W
FR03	Port P53 input/output control bit	0	Port P53 input	
		1	Port P53 output	
FR02	Port P52 input/output control bit	0	Port P52 input	
		1	Port P52 output	
FR01	Port P51 input/output control bit	0	Port P51 input	
		1	Port P51 output	
FR00	Port P50 input/output control bit	0	Port P50 input	
		1	Port P50 output	

Notes 1: “W” represents write enabled.

2: The 4513 Group does not have register FR0.

(5) Timer control register W6

D6/CNTR0 function selection bit is assigned to bit 0, D7/CNTR1 function selection bit is assigned to bit 2.

Set the contents of this register through register A with the **TW6A** instruction.

The contents of register W6 is transferred to register A with the **TAW6** instruction.

Table 2.1.5 shows the timer control register W6.

Table 2.1.5 Timer control register W6

Timer control register W6		at reset : 00002	at RAM back-up : state retained	R/W
W63	CNTR1 output control bit	0	Timer 3 underflow signal output divided by 2	
		1	CNTR1 output control by timer 4 underflow signal divided by 2	
W62	D7/CNTR1 function selection bit	0	D7(I/O)/CNTR1 input	
		1	CNTR1 I/O/D7 (input)	
W61	CNTR0 output control bit	0	Timer 1 underflow signal output divided by 2	
		1	CNTR0 output control by timer 2 underflow signal divided by 2	
W60	D6/CNTR0 function selection bit	0	D6 (I/O)/CNTR0 input	
		1	CNTR0 I/O/D6 (input)	

Notes 1: “R” represents read enabled, and “W” represents write enabled.

2: When setting ports, W63 and W61 are not used.

2.1.3 Port application examples

(1) Key input by key scan

Key matrix can be set up by connecting keys externally because port D output structure is an N-channel open-drain and port P0 has the pull-up resistor.

Outline: The connecting required external part is just keys.

Specifications: Port D is used to output “L” level and port P0 is used to input 16 keys. Multiple key inputs are not detected.

Figure 2.1.1 shows the key input and Figure 2.1.2 shows the key input timing.

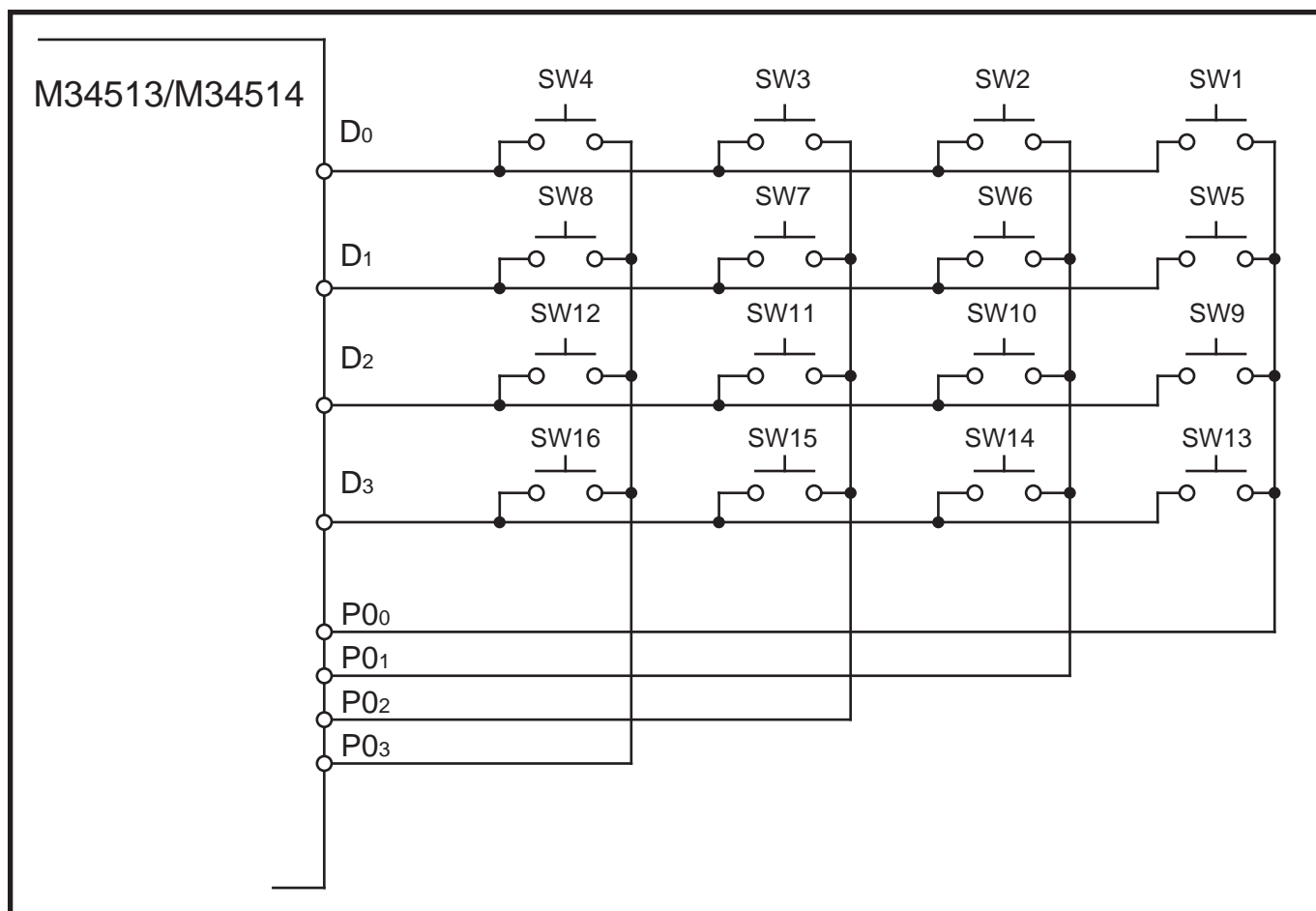

Fig. 2.1.1 Key input by key scan

APPLICATION

2.1 I/O pins

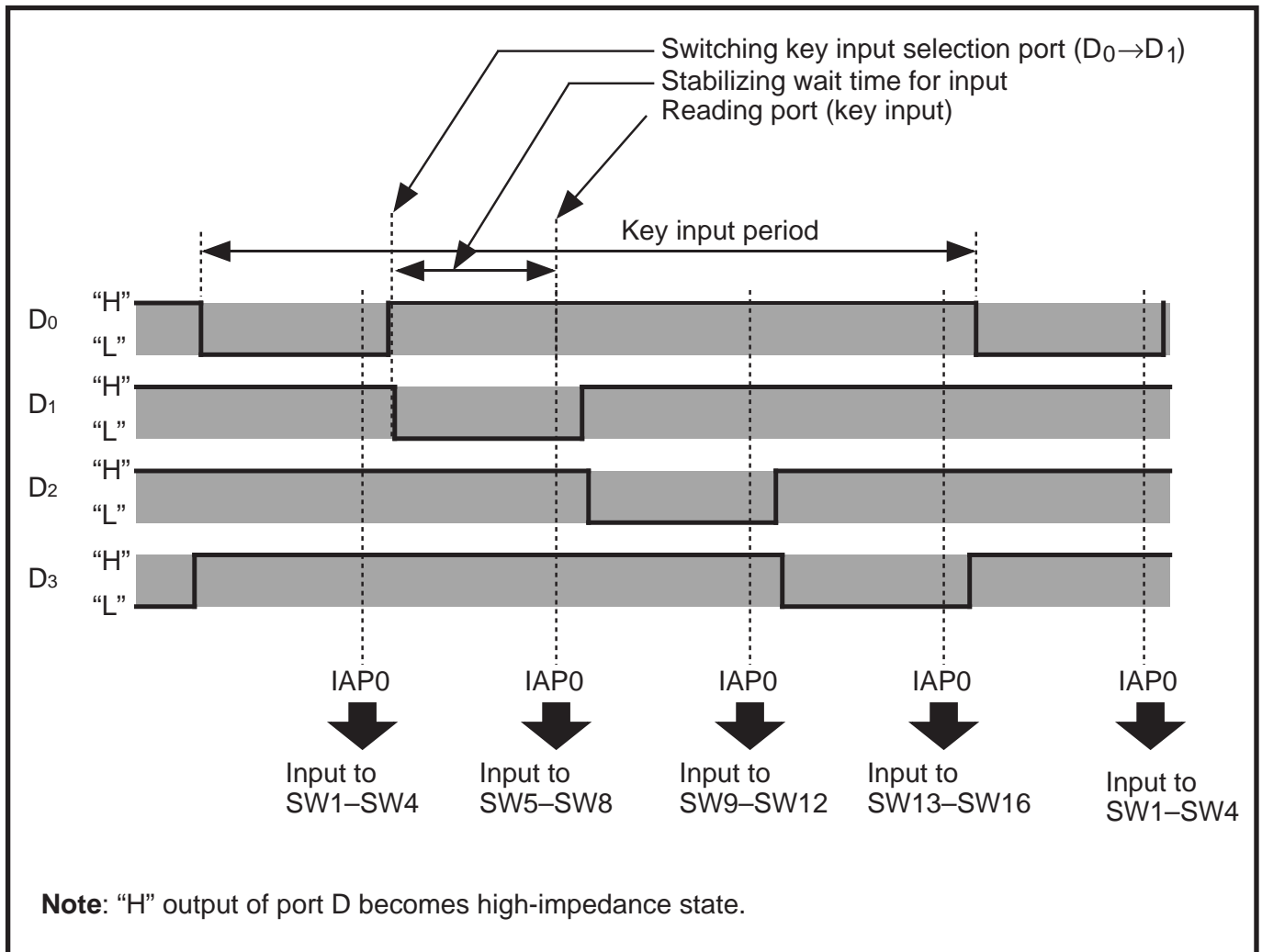

Fig. 2.1.2 Key scan input timing

2.1.4 Notes on use

(1) Note when an I/O port except port P5 is used as an input port

Set the output latch to “1” and input the port value before input. If the output latch is set to “0,” “L” level can be input.

(2) Noise and latch-up prevention

Connect an approximate 0.1 μ F bypass capacitor directly to the VSS line and the VDD line with the thickest possible wire at the shortest distance, and equalize its wiring in width and length.

The CNVSS pin is also used as the VPP pin (programming voltage = 12.5 V) at the built-in PROM version.

Connect the CNVSS/VPP pin to VSS through an approximate 5 k Ω resistor which is connected to the CNVSS/VPP pin at the shortest distance.

(3) Note on multifunction

The input of D6, D7, P20–P22, CMP0-, CMP0+, CMP1-, CMP1+ and the input/output of P30, P31, P40–P43 can be used even when CNTR0, CNTR1, SCK, SOUT, SIN, AIN0–AIN3, INT0, INT1, and AIN4–AIN7 are selected.

(4) Connection of unused pins

Table 2.1.6 shows the connections of unused pins.

(5) SD, RD instructions

When the **SD** and **RD** instructions are used, do not set “10002” or more to register Y.

(6) Analog input pins

When both analog input AIN4–AIN7 and I/O port P4 function are used, note the following;

• **Notes when selecting analog input pins**

Even when register Q2 is used to set the pins for analog input, P40/AIN4–P43/AIN7 continue to function as P40–P43 I/O. Accordingly, when any of them are used as I/O port P4 and others are used as analog input pins, make sure to set the outputs of pins that are set for analog input to “1.” Also, for the port input, the port input function of the pin functions as analog input is undefined.

(7) Notes on port P3

In the 4513 Group, when the **IAP3** instruction is executed, the contents of high-order 2 bits of register A are undefined.

APPLICATION

2.1 I/O pins

Table 2.1.6 connections of unused pins

Pin	Connection
XOUT	Open (when using an external clock).
VDCE	Connect to Vss.
D0–D5	Connect to Vss, or set the output latch to “0” and open.
D6/CNTR0	
D7/CNTR1	
P20/SCK	Connect to Vss.
P21/SOUT	
P22/SIN	
P30/INT0	Connect to Vss, or set the output latch to “0” and open.
P31/INT1	
P32, P33	
P40/AIN4–P43/AIN7	Connect to Vss, or set the output latch to “0” and open.
P50–P53 (Note 1)	When the input mode is selected by software, pull-up to VDD through a resistor or pull-down to Vss. When selecting the output mode, open.
AIN0/CMP0-	Connect to Vss.
AIN1/CMP0+	
AIN2/CMP1-	
AIN3/CMP1+	
P00–P03	Open or connect to Vss (Note 2).
P10–P13	Open or connect to Vss (Note 2).

Notes 1: After system is released from reset, port P5 is in an input mode (direction register FR0 = 00002)

2: When the P00–P03 and P10–P13 are connected to Vss, turn off their pull-up transistors (register PU0i=“0”) and also invalidate the key-on wakeup functions (register K0i=“0”) by software. When these pins are connected to Vss while the key-on wakeup functions are left valid, the system fails to return from RAM back-up state. When these pins are open, turn on their pull-up transistors (register PU0i=“1”) by software, or set the output latch to “0.”

Be sure to select the key-on wakeup functions and the pull-up functions with every two pins. If only one of the two pins for the key-on wakeup function is used, turn on their pull-up transistors by software and also disconnect the other pin. (i = 0, 1, 2, or 3.)

(Note in order to set the output latch to “0” and make pins open)

- After system is released from reset, a port is in a high-impedance state until the output latch of the port is set to “0” by software. Accordingly, the voltage level of pins is undefined and the excess of the supply current may occur.
- To set the output latch periodically is recommended because the value of output latch may change by noise or a program run away (caused by noise).

(Note in order to connect unused pins to Vss or VDD)

- To avoid noise, connect the unused pins to Vss or VDD at the shortest distance using a thick wire.

2.2 Interrupts

The 4513/4514 Group has eight interrupt sources : external (INT0, INT1), timer 1, timer 2, timer 3, timer 4, A-D, and serial I/O.

This section describes individual types of interrupts, related registers, application examples using interrupts and notes.

2.2.1 Interrupt functions

(1) External 0 interrupt (INT0)

The interrupt request occurs by the change of input level of INT0 pin.

The interrupt valid waveform can be selected by the bits 1 and 2 of the interrupt control register I1.

■ External 0 interrupt INT0 processing

- When the interrupt is used

The interrupt occurrence is enabled when the bit 0 of the interrupt control register V1 and the interrupt enable flag INTE are set to "1." When the external 0 interrupt occurs, the interrupt processing is executed from address 0 in page 1.

- When the interrupt is not used

The interrupt is disabled and the **SNZ0** instruction is valid when the bit 0 of register V1 is set to "0."

(2) External 1 interrupt (INT1)

The interrupt request occurs by the change of input level of INT1 pin.

The interrupt valid waveform can be selected by the bits 1 and 2 of the interrupt control register I2.

■ External 1 interrupt INT1 processing

- When the interrupt is used

The interrupt occurrence is enabled when the bit 1 of the interrupt control register V1 and the interrupt enable flag INTE are set to "1." When the external 1 interrupt occurs, the interrupt processing is executed from address 2 in page 1.

- When the interrupt is not used

The interrupt is disabled and the **SNZ1** instruction is valid when the bit 1 of register V1 is set to "0."

(3) Timer 1 interrupt

The interrupt request occurs by the timer 1 underflow.

■ Timer 1 interrupt processing

- When the interrupt is used

The interrupt occurrence is enabled when the bit 2 of the interrupt control register V1 and the interrupt enable flag INTE are set to "1." When the timer 1 interrupt occurs, the interrupt processing is executed from address 4 in page 1.

- When the interrupt is not used

The interrupt is disabled and the **SNZT1** instruction is valid when the bit 2 of register V1 is set to "0."

APPLICATION

2.2 Interrupts

(4) Timer 2 interrupt

The interrupt request occurs by the timer 2 underflow.

■ Timer 2 interrupt processing

- When the interrupt is used

The interrupt occurrence is enabled when the bit 3 of the interrupt control register V1 and the interrupt enable flag INTE are set to "1." When the timer 2 interrupt occurs, the interrupt processing is executed from address 6 in page 1.

- When the interrupt is not used

The interrupt is disabled and the **SNZT2** instruction is valid when the bit 3 of register V1 is set to "0."

(5) Timer 3 interrupt

The interrupt request occurs by the timer 3 underflow.

■ Timer 3 interrupt processing

- When the interrupt is used

The interrupt occurrence is enabled when the bit 0 of the interrupt control register V2 and the interrupt enable flag INTE are set to "1." When the timer 3 interrupt occurs, the interrupt processing is executed from address 8 in page 1.

- When the interrupt is not used

The interrupt is disabled and the **SNZT3** instruction is valid when the bit 0 of register V2 is set to "0."

(6) Timer 4 interrupt

The interrupt request occurs by the timer 4 underflow.

■ Timer 4 interrupt processing

- When the interrupt is used

The interrupt occurrence is enabled when the bit 1 of the interrupt control register V2 and the interrupt enable flag INTE are set to "1." When the timer 4 interrupt occurs, the interrupt processing is executed from address A in page 1.

- When the interrupt is not used

The interrupt is disabled and the **SNZT4** instruction is valid when the bit 1 of register V2 is set to "0."

(7) A-D interrupt

The interrupt request occurs by the end of the A-D conversion.

■ A-D interrupt processing**● When the interrupt is used**

The interrupt occurrence is enabled when the bit 2 of the interrupt control register V2 and the interrupt enable flag INTE are set to "1." When the A-D interrupt occurs, the interrupt processing is executed from address C in page 1.

● When the interrupt is not used

The interrupt is disabled and the **SNZAD** instruction is valid when the bit 2 of register V2 is set to "0."

(8) Serial I/O interrupt

The interrupt request occurs by the end of the serial I/O transmit/receive.

■ Serial I/O interrupt processing**● When the interrupt is used**

The interrupt occurrence is enabled when the bit 3 of the interrupt control register V2 and the interrupt enable flag INTE are set to "1." When the serial I/O interrupt occurs, the interrupt processing is executed from address E in page 1.

● When the interrupt is not used

The interrupt is disabled and the **SNZSI** instruction is valid when the bit 3 of register V2 is set to "0."

2.2.2 Related registers**(1) Interrupt enable flag (INTE)**

The interrupt enable flag (INTE) controls whether the every interrupt enable/disable.

Interrupts are enabled when INTE flag is set to "1" with the **EI** instruction and disabled when INTE flag is cleared to "0" with the **DI** instruction.

When any interrupt occurs, the INTE flag is automatically cleared to "0," so that other interrupts are disabled until the **EI** instruction is executed.

Note: The interrupt enabled with the **EI** instruction is performed after the **EI** instruction and one more instruction.

APPLICATION

2.2 Interrupts

(2) Interrupt control register V1

Interrupt enable bits of external 0, external 1, timer 1 and timer 2 are assigned to register V1. Set the contents of this register through register A with the **TV1A** instruction. In addition, the **TAV1** instruction can be used to transfer the contents of register V1 to register A. Table 2.2.1 shows the interrupt control register V1.

Table 2.2.1 Interrupt control register V1

Interrupt control register V1		at reset : 0000 ₂	at RAM back-up : 0000 ₂	R/W
V13	Timer 2 interrupt enable bit	0	Interrupt disabled (SNZT2 instruction is valid)	
		1	Interrupt enabled (SNZT2 instruction is invalid)	
V12	Timer 1 interrupt enable bit	0	Interrupt disabled (SNZT1 instruction is valid)	
		1	Interrupt enabled (SNZT1 instruction is invalid)	
V11	External 1 interrupt enable bit	0	Interrupt disabled (SNZ1 instruction is valid)	
		1	Interrupt enabled (SNZ1 instruction is invalid)	
V10	External 0 interrupt enable bit	0	Interrupt disabled (SNZ0 instruction is valid)	
		1	Interrupt enabled (SNZ0 instruction is invalid)	

Note: “R” represents read enabled, and “W” represents write enabled.

(3) Interrupt control register V2

Interrupt enable bits of timer 3, timer 4, A-D, and serial I/O are assigned to register V2. Set the contents of this register through register A with the **TV2A** instruction. In addition, the **TAV2** instruction can be used to transfer the contents of register V2 to register A. Table 2.2.2 shows the interrupt control register V2.

Table 2.2.2 Interrupt control register V2

Interrupt control register V2		at reset : 0000 ₂	at RAM back-up : 0000 ₂	R/W
V23	Serial I/O interrupt enable bit	0	Interrupt disabled (SNZSI instruction is valid)	
		1	Interrupt enabled (SNZSI instruction is invalid)	
V22	A-D interrupt enable bit	0	Interrupt disabled (SNZAD instruction is valid)	
		1	Interrupt enabled (SNZAD instruction is invalid)	
V21	Timer 4 interrupt enable bit	0	Interrupt disabled (SNZT4 instruction is valid)	
		1	Interrupt enabled (SNZT4 instruction is invalid)	
V20	Timer 3 interrupt enable bit	0	Interrupt disabled (SNZT3 instruction is valid)	
		1	Interrupt enabled (SNZT3 instruction is invalid)	

Note: “R” represents read enabled, and “W” represents write enabled.

(4) Interrupt request flag

The activated condition for each interrupt is examined. Each interrupt request flag is set to “1” when the activated condition is satisfied, even if the interrupt is disabled by the INTE flag or its interrupt enable bit.

Each interrupt request flag is cleared to “0” when either;

- an interrupt occurs, or
- the next instruction is skipped with a skip instruction.

(5) Interrupt control register I1

The INT0 pin timer 1 control enable bit is assigned to bit 0, INT0 pin edge detection circuit control bit is assigned to bit 1, and interrupt valid waveform for INT0 pin/return level selection bit is assigned to bit 2.

Set the contents of this register through register A with the **T11A** instruction.

In addition, the **TAI1** instruction can be used to transfer the contents of register I1 to register A.

Table 2.2.3 shows the interrupt control register I1.

Table 2.2.3 Interrupt control register I1

Interrupt control register I1		at reset : 0000 ₂	at RAM back-up : state retained	R/W
I13	Not used	0	This bit has no function, but read/write is enabled.	
		1		
I12	Interrupt valid waveform for INT0 pin/return level selection bit (Note 2)	0	Falling waveform ("L" level of INT0 pin is recognized with the SNZIO instruction)/"L" level	
		1	Rising waveform ("H" level of INT0 pin is recognized with the SNZIO instruction)/"H" level	
I11	INT0 pin edge detection circuit control bit	0	One-sided edge detected	
		1	Both edges detected	
I10	INT0 pin timer 1 control enable bit	0	Disabled	
		1	Enabled	

Notes 1: "R" represents read enabled, and "W" represents write enabled.

2: When the contents of I12 is changed, the external interrupt request flag EXF0 may be set. Accordingly, clear EXF0 flag with the **SNZO** instruction.

(6) Interrupt control register I2

The INT1 pin timer 3 control enable bit is assigned to bit 0, the INT1 pin edge detection circuit control bit is assigned to bit 1 and the interrupt valid waveform for INT1 pin/return level selection bit is assigned to bit 2.

Set the contents of this register through register A with the **T12A** instruction.

In addition, the **TAI2** instruction can be used to transfer the contents of register I2 to register A.

Table 2.2.4 shows the interrupt control register I2.

Table 2.2.4 Interrupt control register I2

Interrupt control register I2		at reset : 0000 ₂	at RAM back-up : state retained	R/W
I23	Not used	0	This bit has no function, but read/write is enabled.	
		1		
I22	Interrupt valid waveform for INT1 pin/return level selection bit (Note 2)	0	Falling waveform ("L" level of INT1 pin is recognized with the SNZI1 instruction)/"L" level	
		1	Rising waveform ("H" level of INT1 pin is recognized with the SNZI1 instruction)/"H" level	
I21	INT1 pin edge detection circuit control bit	0	One-sided edge detected	
		1	Both edges detected	
I20	INT1 pin timer 3 control enable bit	0	Disabled	
		1	Enabled	

Notes 1: "R" represents read enabled, and "W" represents write enabled.

2: When the contents of I22 is changed, the external interrupt request flag EXF1 may be set. Accordingly, clear EXF1 flag with the **SNZ1** instruction.

APPLICATION

2.2 Interrupts

2.2.3 Interrupt application examples

(1) External 0 interrupt

The INT0 pin is used for external 0 interrupt, of which valid waveforms can be chosen, which can recognize the change of both edges (“H”→“L” or “L”→“H”).

Outline: An external 0 interrupt can be used by dealing with the change of edge (“H”→“L” or “L”→“H”) in both directions as a trigger.

Specifications: An interrupt occurs by the change of an external signals edge (“H”→“L” or “L”→“H”).

Figure 2.2.1 shows an operation example of an external 0 interrupt, and Figure 2.2.2 shows a setting example of an external 0 interrupt.

(2) External 1 interrupt

The INT1 pin is used for external 1 interrupt, of which valid waveforms can be chosen, which can recognize the change of both edges (“H”→“L” or “L”→“H”).

Outline: An external 1 interrupt can be used by dealing with the change of edge (“H”→“L” or “L”→“H”) in both directions as a trigger.

Specifications: An interrupt occurs by the change of an external signals edge (“H”→“L” or “L”→“H”).

Figure 2.2.3 shows an operation example of an external 1 interrupt, and Figure 2.2.4 shows a setting example of an external 1 interrupt.

(3) Timer 1 interrupt

Constant period interrupts by a setting value to timer 1 can be used.

Outline: The constant period interrupts by the timer 1 underflow signal can be used.

Specifications: Prescaler and timer 1 divide the system clock frequency $f(XIN) = 4.0$ MHz, and the timer 1 interrupt occurs every 1 ms.

Figure 2.2.5 shows a setting example of the timer 1 constant period interrupt.

(4) Timer 2 interrupt

Constant period interrupts by a setting value to timer 2 can be used.

Outline: The constant period interrupts by the timer 2 underflow signal can be used.

Specifications: Timer 2 divides the 16-bit fixed dividing frequency timer, and the timer 2 interrupt occurs every about 2 sec.

Figure 2.2.6 shows a setting example of the timer 2 constant period interrupt.

(5) Timer 3 interrupt

Constant period interrupts by a setting value to timer 3 can be used.

Outline: The constant period interrupts by the timer 3 underflow signal can be used.

Specifications: Prescaler and timer 3 divide the system clock frequency $f(XIN) = 4.0$ MHz, and the timer 3 interrupt occurs every 1 ms.

Figure 2.2.7 shows a setting example of the timer 3 constant period interrupt.

(6) Timer 4 interrupt

Constant period interrupts by a setting value to timer 4 can be used.

Outline: The constant period interrupts by the timer 4 underflow signal can be used.

Specifications: Prescaler, timer 3 and timer 4 divide the system clock frequency $f(XIN) = 4.0$ MHz, and the timer 4 interrupt occurs every 250 ms.

Figure 2.2.8 shows a setting example of the timer 4 constant period interrupt.

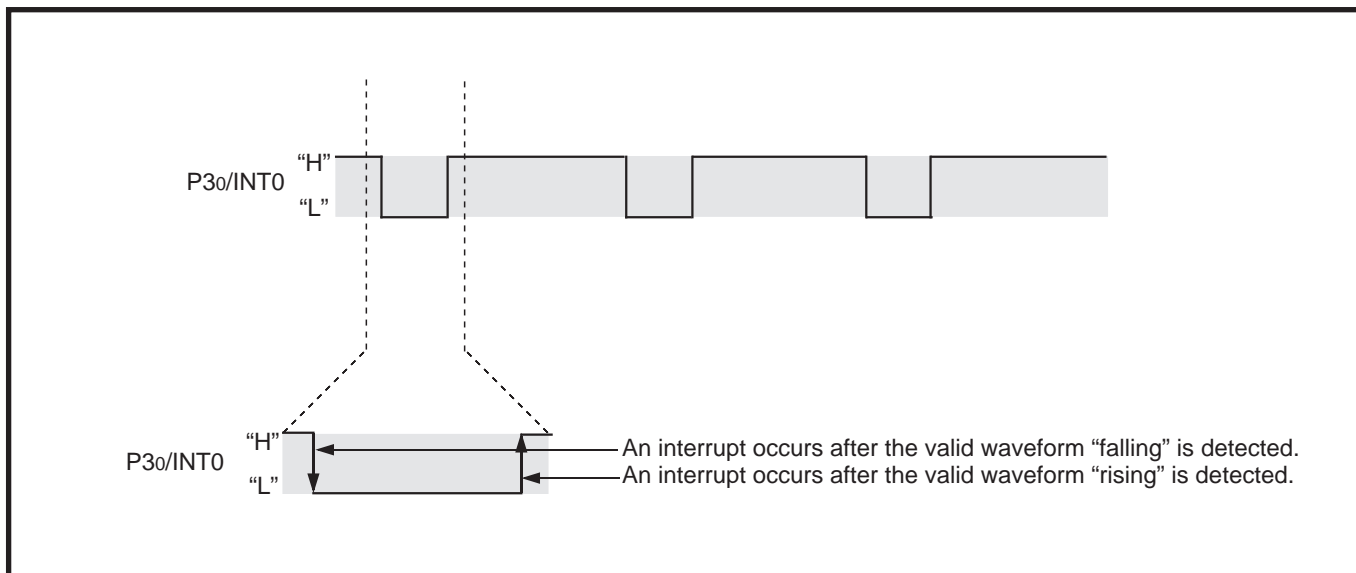

Fig. 2.2.1 INT0 interrupt operation example

APPLICATION

2.2 Interrupts

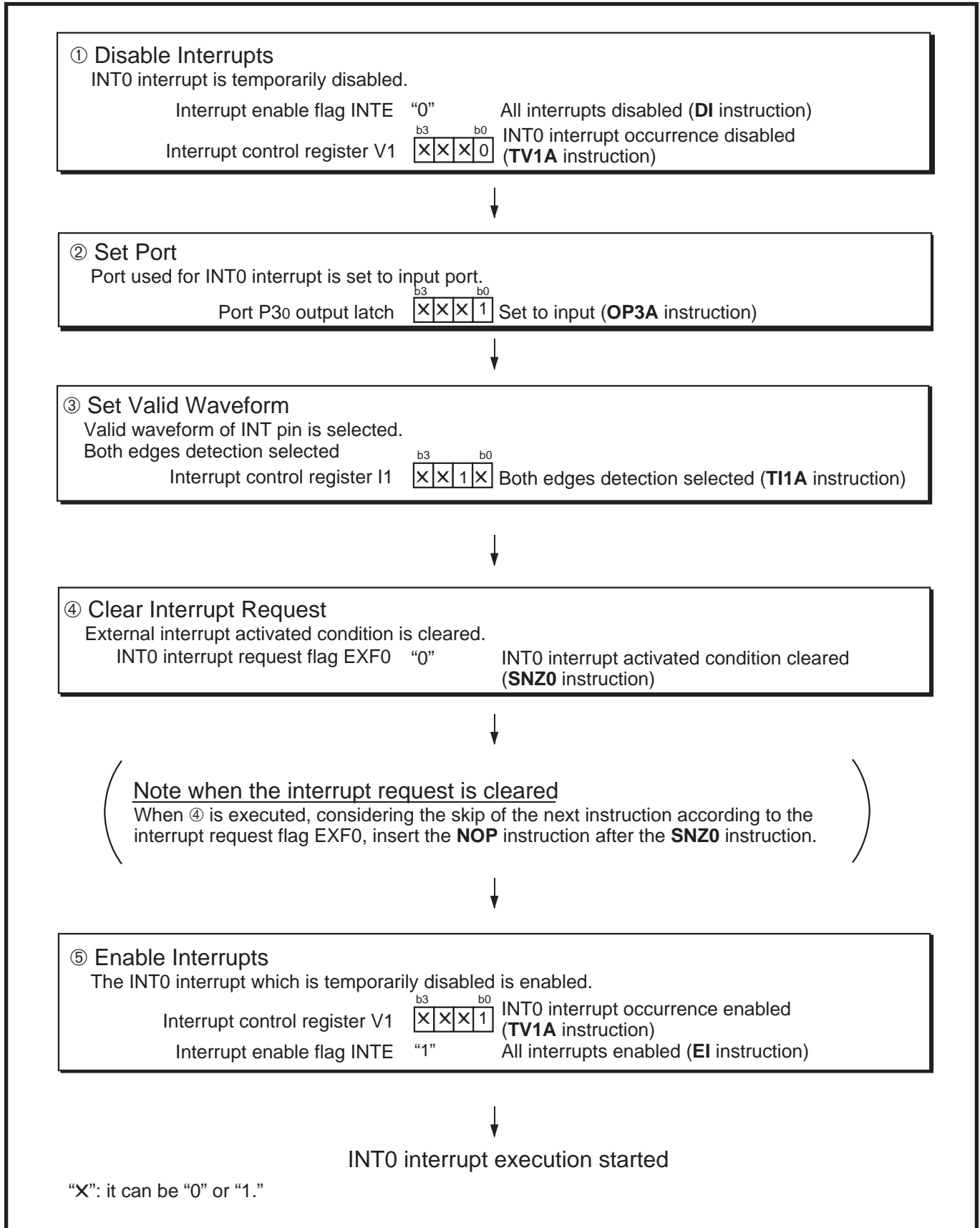

Fig. 2.2.2 INT0 interrupt setting example

Note: The valid waveforms causing the interrupt must be retained at their level for 4 cycles or more of system clock.

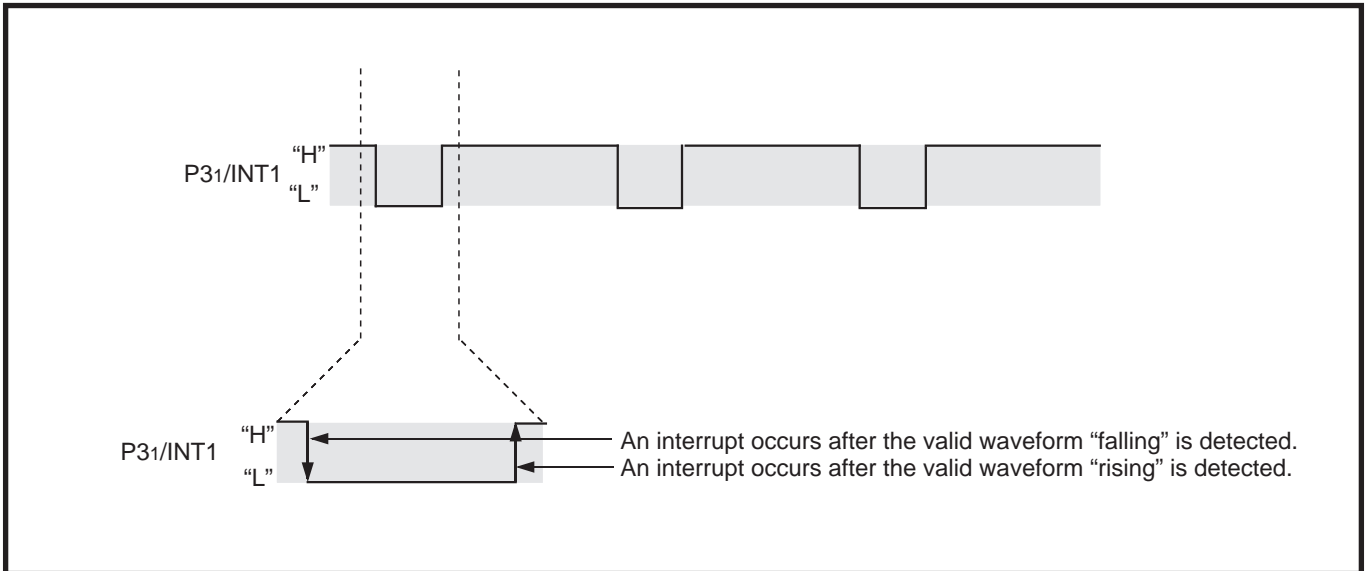

Fig. 2.2.3 INT1 interrupt operation example

APPLICATION

2.2 Interrupts

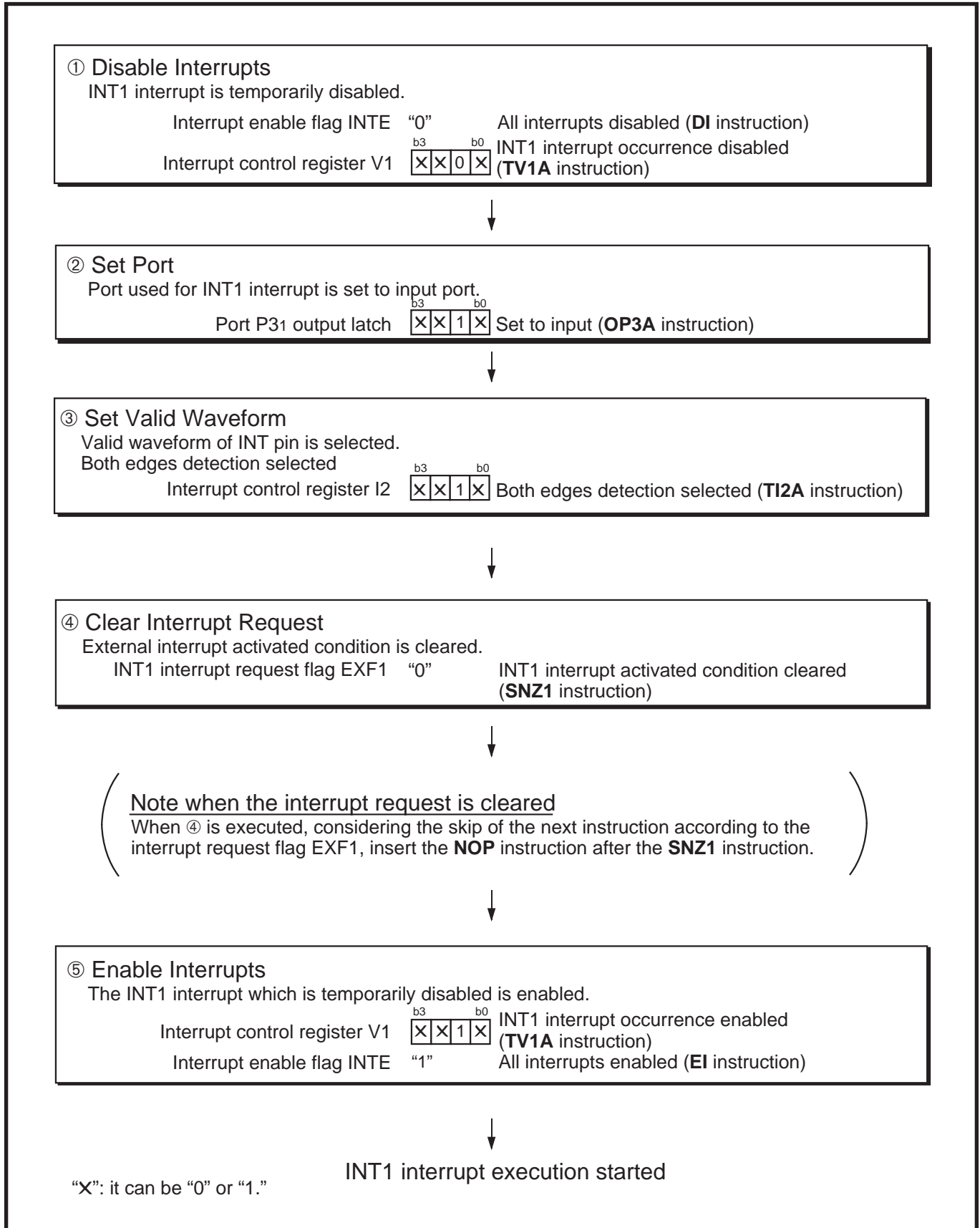

Fig. 2.2.4 INT1 interrupt setting example

Note: The valid waveforms causing the interrupt must be retained at their level for 4 cycles or more of system clock.

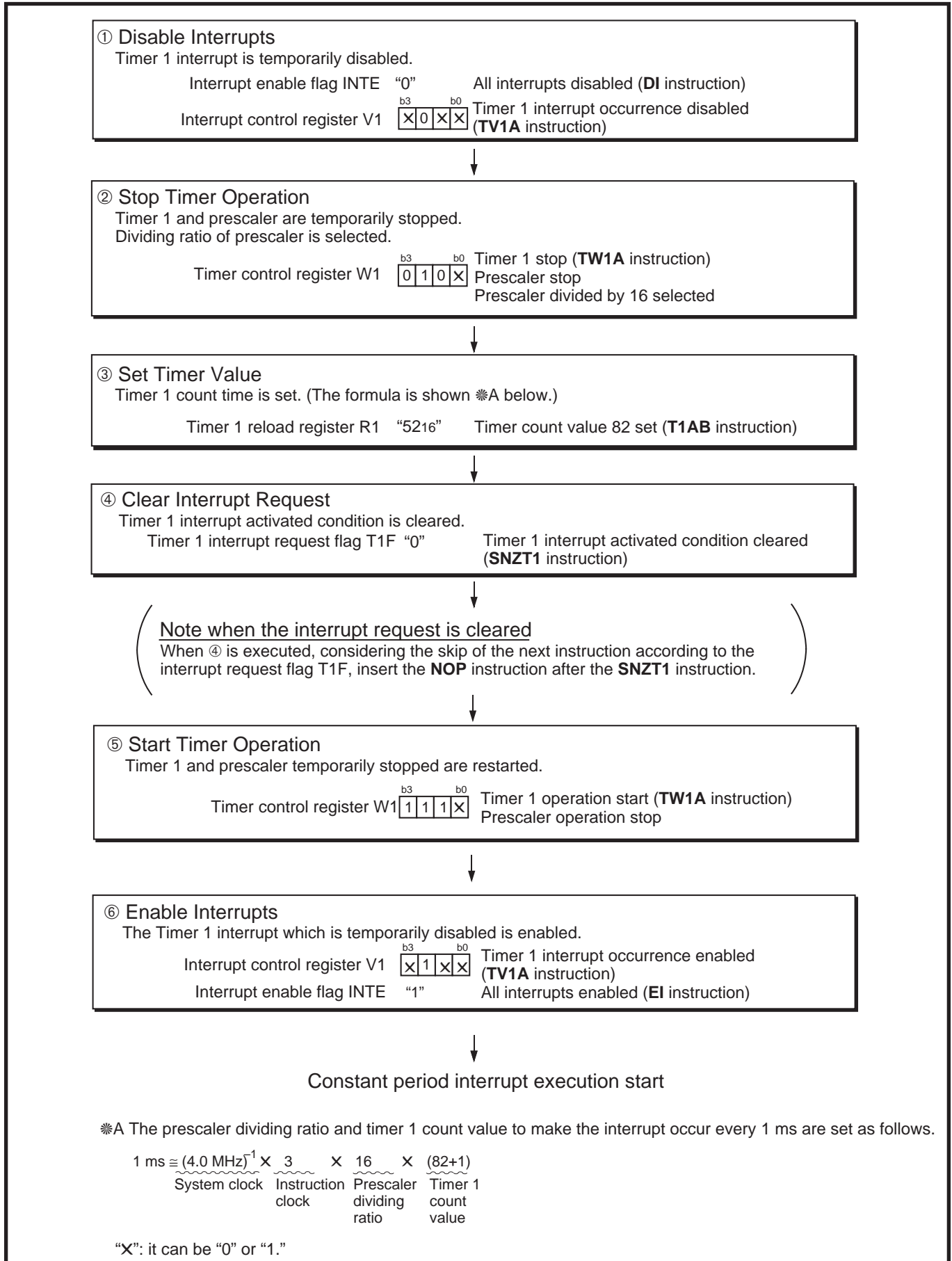

Fig. 2.2.5 Timer 1 constant period interrupt setting example

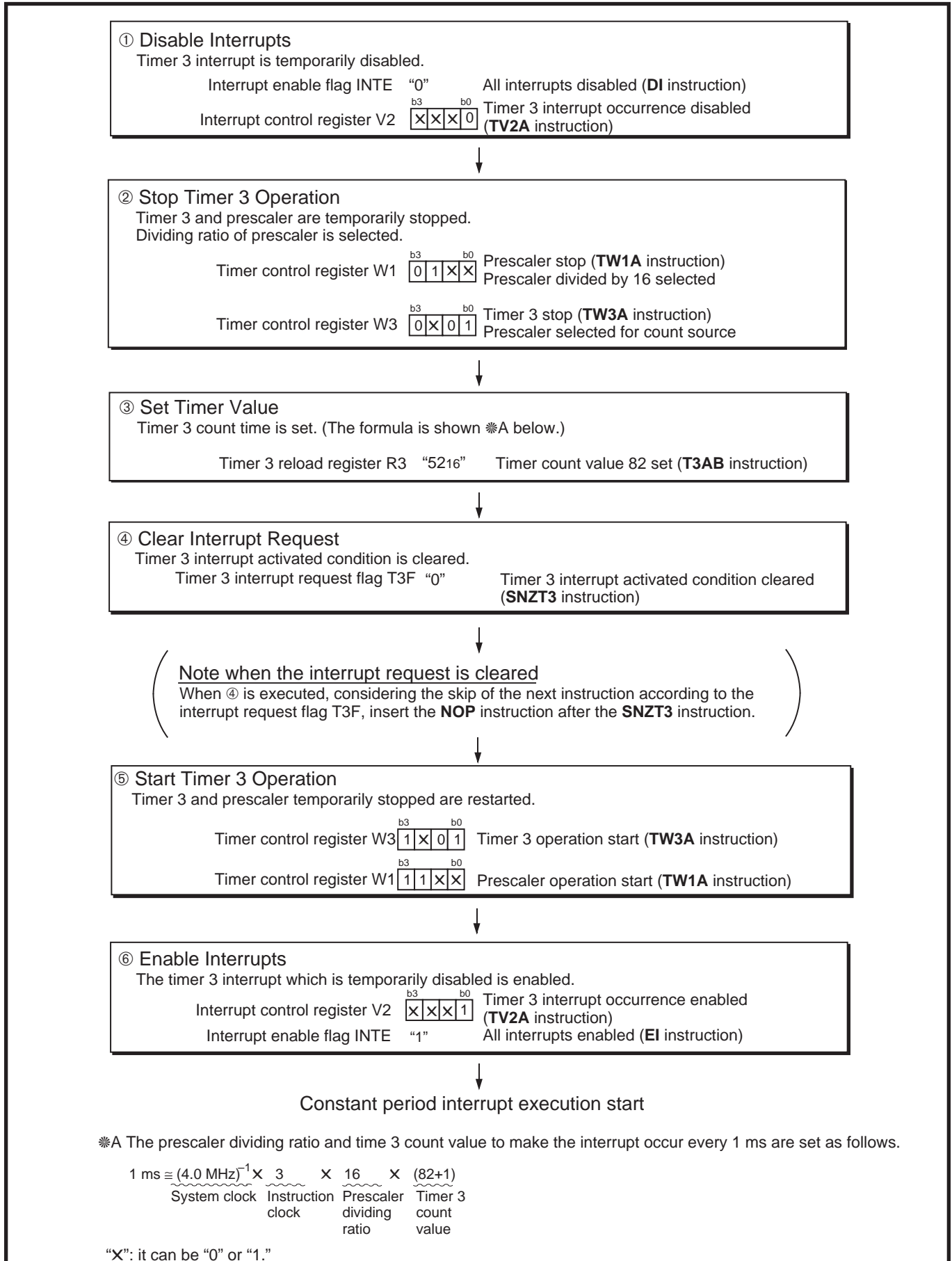

Fig. 2.2.7 Timer 3 constant period interrupt setting example

APPLICATION

2.2 Interrupts

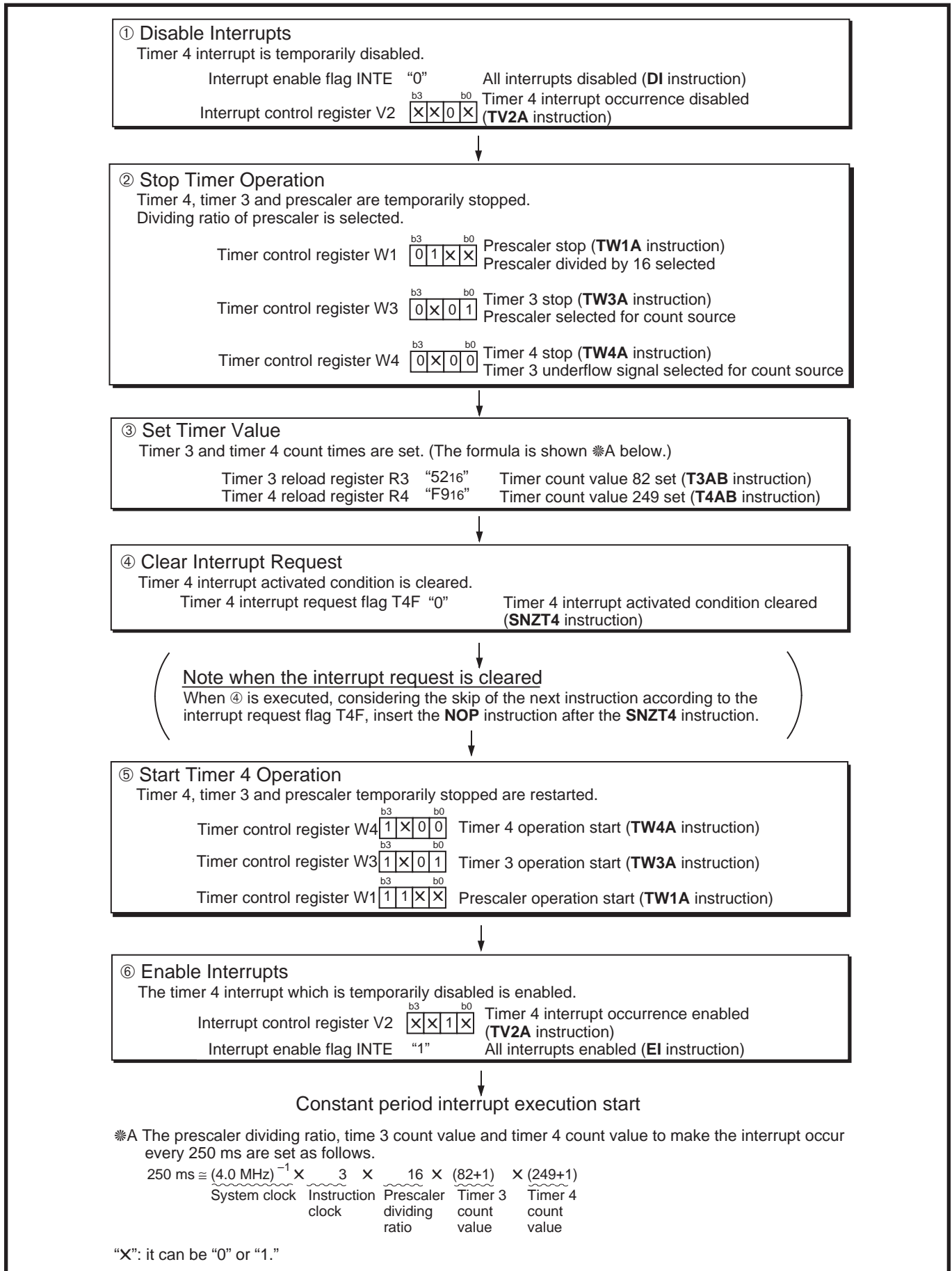

Fig. 2.2.8 Timer 4 constant period interrupt setting example

2.2.4 Notes on use

(1) Setting of INT0 interrupt valid waveform

Depending on the input state of P30/INT0 pin, the external interrupt request flag (EXF0) may be set to “1” when the interrupt valid waveform is changed. Accordingly, set a value to the bit 2 of register I1, and execute the **SNZO** instruction to clear the EXF0 flag to “0” after executing at least one instruction.

(2) Setting of INT1 interrupt valid waveform

Depending on the input state of P31/INT1 pin, the external interrupt request flag (EXF1) may be set to “1” when the interrupt valid waveform is changed. Accordingly, set a value to the bit 2 of register I2, and execute the **SNZ1** instruction to clear the EXF1 flag to “0” after executing at least one instruction.

(3) Multiple interrupts

Multiple interrupts cannot be used in the 4513/4514 Group.

(4) Notes on interrupt processing

When the interrupt occurs, at the same time, the interrupt enable flag INTE is cleared to “0” (interrupt disable state). In order to enable the interrupt at the same time when system returns from the interrupt, write **EI** and **RTI** instructions continuously.

(5) P30/INT0 pin

The P30/INT0 pin need not be selected the external interrupt input INT function or the normal output port P30 function. However, the EXF0 flag is set to “1” when a valid waveform is input to INT0 pin even if it is used as an I/O port P30.

(6) P31/INT1 pin

The P31/INT1 pin need not be selected the external interrupt input INT function or the normal output port P31 function. However, the EXF1 flag is set to “1” when a valid waveform is input to INT1 pin even if it is used as an I/O port P31.

(7) EPOF instruction

Be sure to disable interrupts by executing the **DI** instruction before executing the **EPOF** instruction.

APPLICATION

2.3 Timers

2.3 Timers

The 4513/4514 Group has four 8-bit timers (each has a reload register) and a 16-bit fixed dividing frequency timer which has the watchdog timer function.

This section describes individual types of timers, related registers, application examples using timers and notes.

2.3.1 Timer functions

(1) Timer 1

■ Timer operation

(Timer 1 has the timer 1 count start trigger function from P30/INT0 pin input)

(2) Timer 2

■ Timer operation

(3) Timer 3

■ Timer operation

(Timer 3 has the timer 3 count start trigger function from P31/INT1 pin input)

(4) Timer 4

■ Timer operation

(5) 16-bit timer

■ Timer 2 count source

(16-bit fixed dividing frequency)

■ Watchdog function

Watchdog timer provides a method to reset the system when a program runs incorrectly.

When the count value of timer WDT reaches "BFFF₁₆" or "3FFF₁₆," the WDF1 flag is set to "1."

If the **WRST** instruction is never executed while timer WDT counts 32767, WDF2 flag is set to "1" to reset the microcomputer.

2.3.2 Related registers

(1) Interrupt control register V1

The timer 1 interrupt enable bit is assigned to bit 2, and the timer 2 interrupt enable bit is assigned to bit 3.

Set the contents of this register through register A with the **TV1A** instruction. The **TAV1** instruction can be used to transfer the contents of register V1 to register A.

Table 2.3.1 shows the interrupt control register V1.

Table 2.3.1 Interrupt control register V1

Interrupt control register V1		at reset : 0000 ₂	at RAM back-up : 0000 ₂	R/W
V13	Timer 2 interrupt enable bit	0	Interrupt disabled (SNZT2 instruction is valid)	
		1	Interrupt enabled (SNZT2 instruction is invalid)	
V12	Timer 1 interrupt enable bit	0	Interrupt disabled (SNZT1 instruction is valid)	
		1	Interrupt enabled (SNZT1 instruction is invalid)	
V11	External 1 interrupt enable bit	0	Interrupt disabled (SNZ1 instruction is valid)	
		1	Interrupt enabled (SNZ1 instruction is invalid)	
V10	External 0 interrupt enable bit	0	Interrupt disabled (SNZ0 instruction is valid)	
		1	Interrupt enabled (SNZ0 instruction is invalid)	

Notes 1: "R" represents read enabled, and "W" represents write enabled.

2: When timer is used, V11 and V10 are not used.

(2) Interrupt control register V2

The timer 3 interrupt enable bit is assigned to bit 0, and the timer 4 interrupt enable bit is assigned to bit 1.

Set the contents of this register through register A with the **TV2A** instruction. The **TAV2** instruction can be used to transfer the contents of register V2 to register A.

Table 2.3.2 shows the interrupt control register V2.

Table 2.3.2 Interrupt control register V2

Interrupt control register V2		at reset : 0000 ₂	at RAM back-up : 0000 ₂	R/W
V23	Serial I/O interrupt enable bit	0	Interrupt disabled (SNZSI instruction is valid)	
		1	Interrupt enabled (SNZSI instruction is invalid)	
V22	A-D interrupt enable bit	0	Interrupt disabled (SNZAD instruction is valid)	
		1	Interrupt enabled (SNZAD instruction is invalid)	
V21	Timer 4 interrupt enable bit	0	Interrupt disabled (SNZT4 instruction is valid)	
		1	Interrupt enabled (SNZT4 instruction is invalid)	
V20	Timer 3 interrupt enable bit	0	Interrupt disabled (SNZT3 instruction is valid)	
		1	Interrupt enabled (SNZT3 instruction is invalid)	

Notes 1: "R" represents read enabled, and "W" represents write enabled.

2: When timer is used, V22 and V23 are not used.

APPLICATION

2.3 Timers

(3) Timer control register W1

The timer 1 count start synchronous circuit control bit is assigned to bit 0, the timer 1 control bit is assigned to bit 1, the prescaler dividing ratio selection bit is assigned to bit 2, and the prescaler control bit is assigned to bit 3.

Set the contents of this register through register A with the **TW1A** instruction. The **TAW1** instruction can be used to transfer the contents of register W1 to register A.

Table 2.3.3 shows the timer control register W1.

Table 2.3.3 Timer control register W1

Timer control register W1		at reset : 0000 ₂	at RAM back-up : 0000 ₂	R/W
W13	Prescaler control bit	0	Stop (state initialized)	
		1	Operating	
W12	Prescaler dividing ratio selection bit	0	Instruction clock divided by 4	
		1	Instruction clock divided by 16	
W11	Timer 1 control bit	0	Stop (state retained)	
		1	Operating	
W10	Timer 1 count synchronous circuit control bit	0	Count start synchronous circuit not selected	
		1	Count start synchronous circuit selected	

Note: “R” represents read enabled, and “W” represents write enabled.

(4) Timer control register W2

The timer 2 count source selection bits are assigned to bits 0 and 1, and the timer 2 control bit is assigned to bit 3.

Set the contents of this register through register A with the **TW2A** instruction. The **TAW2** instruction can be used to transfer the contents of register W2 to register A.

Table 2.3.4 shows the timer control register W2.

Table 2.3.4 Timer control register W2

Timer control register W2		at reset : 0000 ₂	at RAM back-up : state retained	R/W
W23	Timer 2 control bit	0	Stop (state retained)	
		1	Operating	
W22	Not used	0	This bit has no function, but read/write is enabled.	
		1		
W21	Timer 2 count source selection bits	W21	W20	Count source
		0	0	Timer 1 underflow signal
0		1	Prescaler output	
W20		1	0	CNTR0 input
	1	1	16-bit timer (WDT) underflow signal	

Note: “R” represents read enabled, and “W” represents write enabled.

(5) Timer control register W3

The timer 3 count source selection bits are assigned to bits 0 and 1, the timer 3 count start synchronous circuit control bit is assigned to bit 2 and the timer 3 control bit is assigned to bit 3.

Set the contents of this register through register A with the **TW3A** instruction. The **TAW3** instruction can be used to transfer the contents of register W3 to register A.

Table 2.3.5 shows the timer control register W3.

Table 2.3.5 Timer control register W3

Timer control register W3		at reset : 0000 ₂		at RAM back-up : state retained	R/W
W33	Timer 3 control bit	0	Stop (state retained)		
		1	Operating		
W32	Timer 3 count start synchronous circuit control bit	0	Count start synchronous circuit not selected		
		1	Count start synchronous circuit selected		
W31	Timer 3 count source selection bits	W31	W30	Count source	
		0	0	Timer 2 underflow signal	
0		1	Prescaler output		
W30		1	0	Not available	
	1	1	Not available		

Note: “R” represents read enabled, and “W” represents write enabled.

(6) Timer control register W4

The timer 4 count source selection bits are assigned to bits 0 and 1, and the timer 4 control bit is assigned to bit 3.

Set the contents of this register through register A with the **TW4A** instruction. The **TAW4** instruction can be used to transfer the contents of register W4 to register A.

Table 2.3.6 shows the timer control register W4.

Table 2.3.6 Timer control register W4

Timer control register W4		at reset : 0000 ₂		at RAM back-up : state retained	R/W
W43	Timer 4 control bit	0	Stop (state retained)		
		1	Operating		
W42	Not used	0	This bit has no function, but read/write is enabled.		
		1			
W41	Timer 4 count source selection bits	W41	W40	Count source	
		0	0	Timer 3 underflow signal	
0		1	Prescaler output		
W40		1	0	CNTR1 input	
	1	1	Not available		

Note: “R” represents read enabled, and “W” represents write enabled.

APPLICATION

2.3 Timers

2.3.3 Timer application examples

(1) Timer operation: measurement of constant period

The constant period by the setting timer count value can be measured.

Outline: The constant period by the timer 1 underflow signal can be measured.

Specifications: Timer 1 and prescaler divides the system clock frequency $f(XIN) = 4.0$ MHz, and the timer 1 interrupt request occurs every 3 ms.

Figure 2.3.3 shows the setting example of the constant period measurement.

(2) CNTR0 output operation: piezoelectric buzzer output

Outline: Square wave output from timer 1 can be used for piezoelectric buzzer output.

Specifications: 4 kHz square wave is output from the CNTR0 pin at system clock frequency $f(XIN) = 4.0$ MHz. Also, timer 1 interrupt occurs simultaneously.

Figure 2.3.1 shows the peripheral circuit example, and Figure 2.3.4 shows the setting example of CNTR0 output.

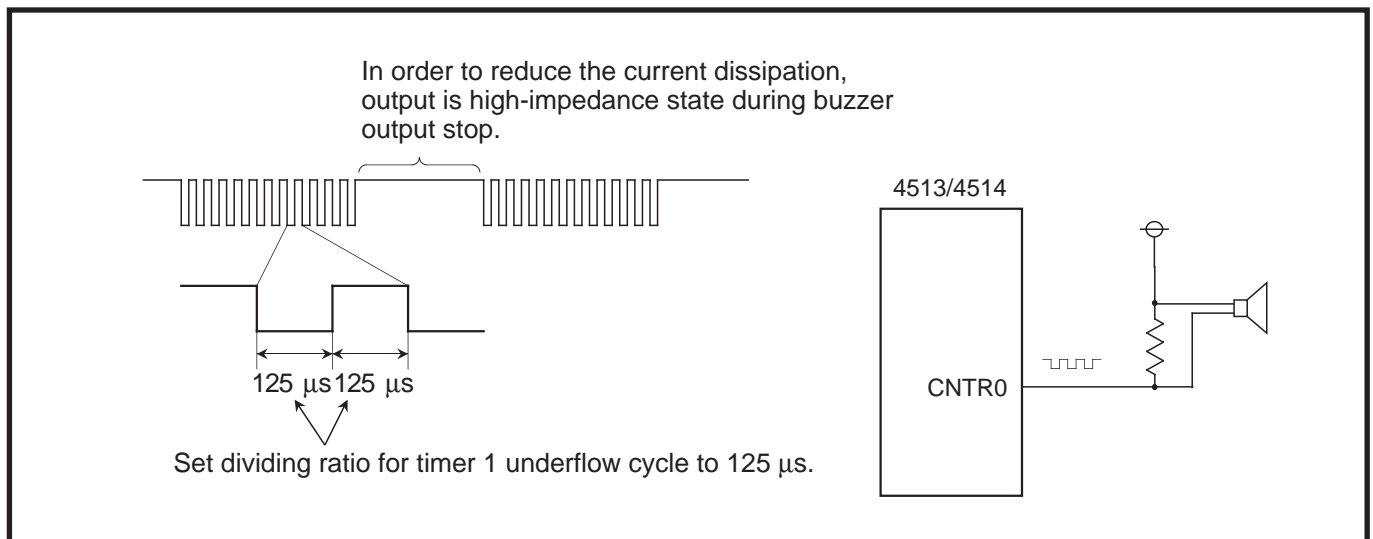

Fig. 2.3.1 Peripheral circuit example

(3) CNTR0 input operation: event count

Outline: Count operation can be performed by using the signal (rising waveform) input from CNTR0 pin as the event.

Specifications: The low-frequency pulse from external as the timer 2 count source is input to CNTR0 pin, and the timer 2 interrupt request occurs every 100 counts.

Figure 2.3.5 shows the setting example of CNTR0 input.

(4) CNTR1 output control: square wave output control

Outline: The output/stop of square wave from timer 3 every timer 4 underflow can be controlled.

Specifications: 4 kHz square wave is output from timer 3 at system clock frequency $f(XIN) = 4.0$ MHz. Also, timer 4 controls ON/OFF of square wave every constant period.

Figure 2.3.6 shows the setting example of CNTR1 output.

(5) Timer operation: timer start by external input

Outline: The constant period can be measured by external input.

Specifications: Timer 1 operates by INT0 input as a trigger and an interrupt occurs after 1 ms.

Figure 2.3.7 and Figure 2.3.8 show the setting example of timer start.

(6) Watchdog timer

Watchdog timer provides a method to reset the system when a program run-away occurs.

In the 4513/4514 Group, bit 15 of 16-bit timer is counted twice for the watchdog timer.

Accordingly, when the watchdog timer function is set to be valid, execute the **WRST** instruction at a certain period which consists of timer 16-bit timers' 32767 counts or less (execute **WRST** instruction at a cycle of 32766 machine cycles or less).

Outline: Execute the **WRST** instruction in 16-bit timer's 32767 counts at the normal operation. If a program runs incorrectly, the **WRST** instruction is not executed and system reset occurs.

Specifications: System clock frequency $f(XIN) = 4.0$ MHz is used, and program run-away is detected by executing the **WRST** instruction in 24 ms.

Figure 2.3.2 shows the watchdog timer function, and Figure 2.3.9 shows the example of watchdog timer.

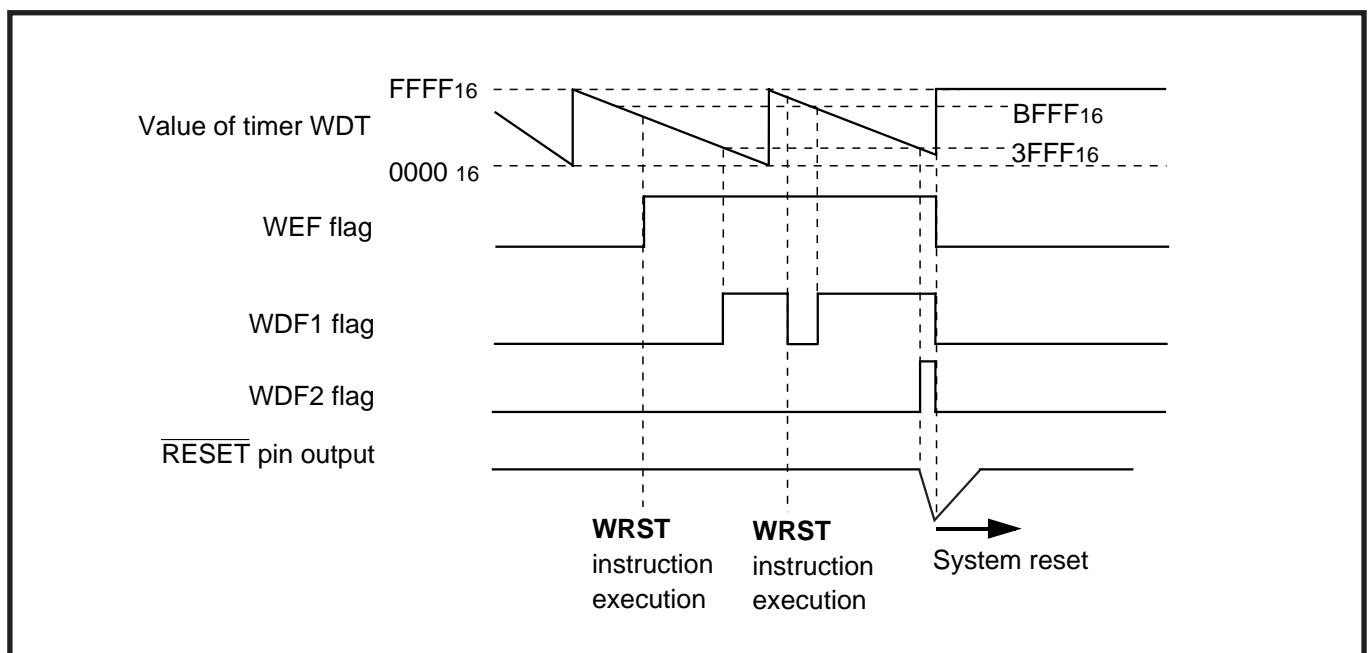

Fig. 2.3.2 Watchdog timer function

APPLICATION

2.3 Timers

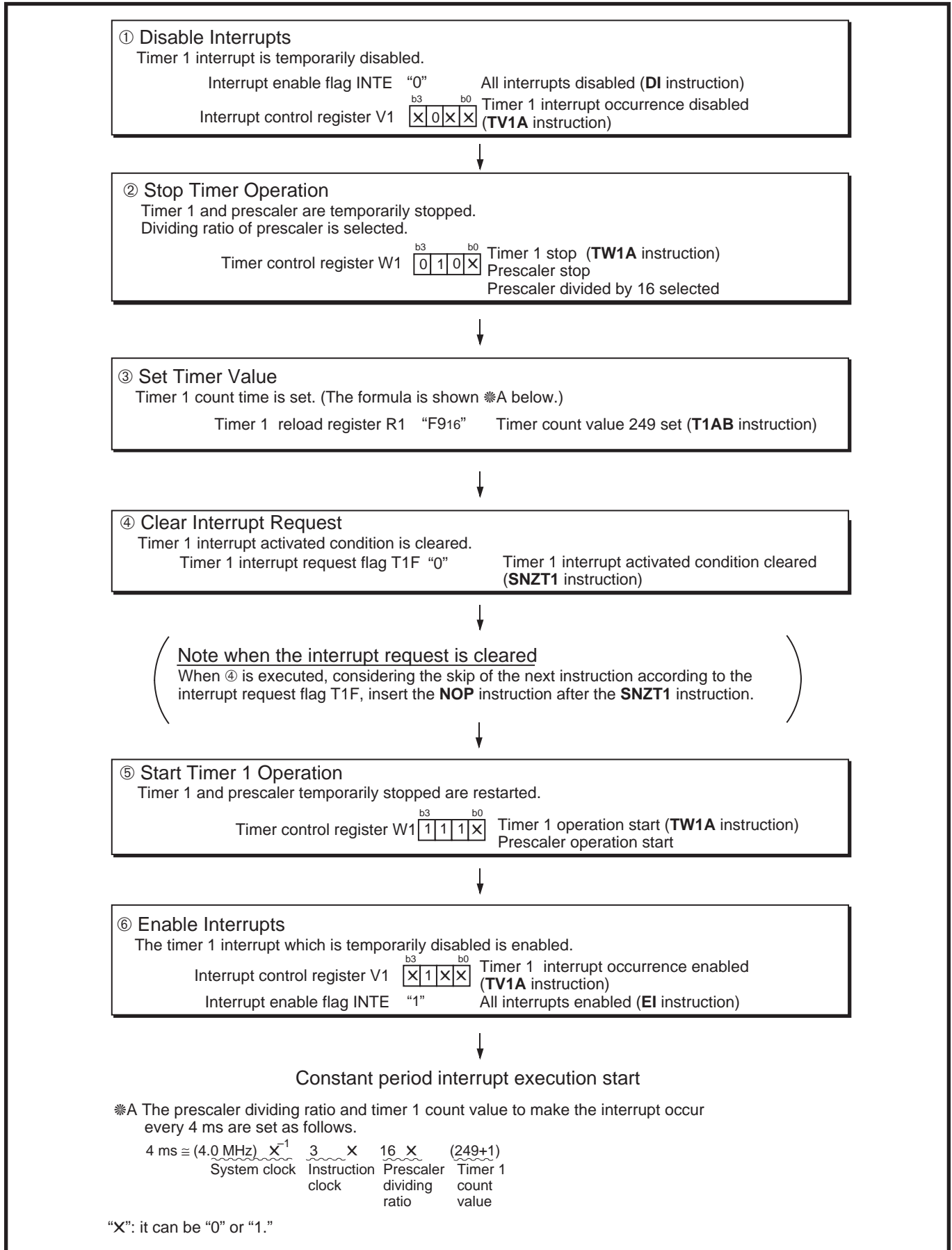

Fig. 2.3.3 Constant period measurement setting example

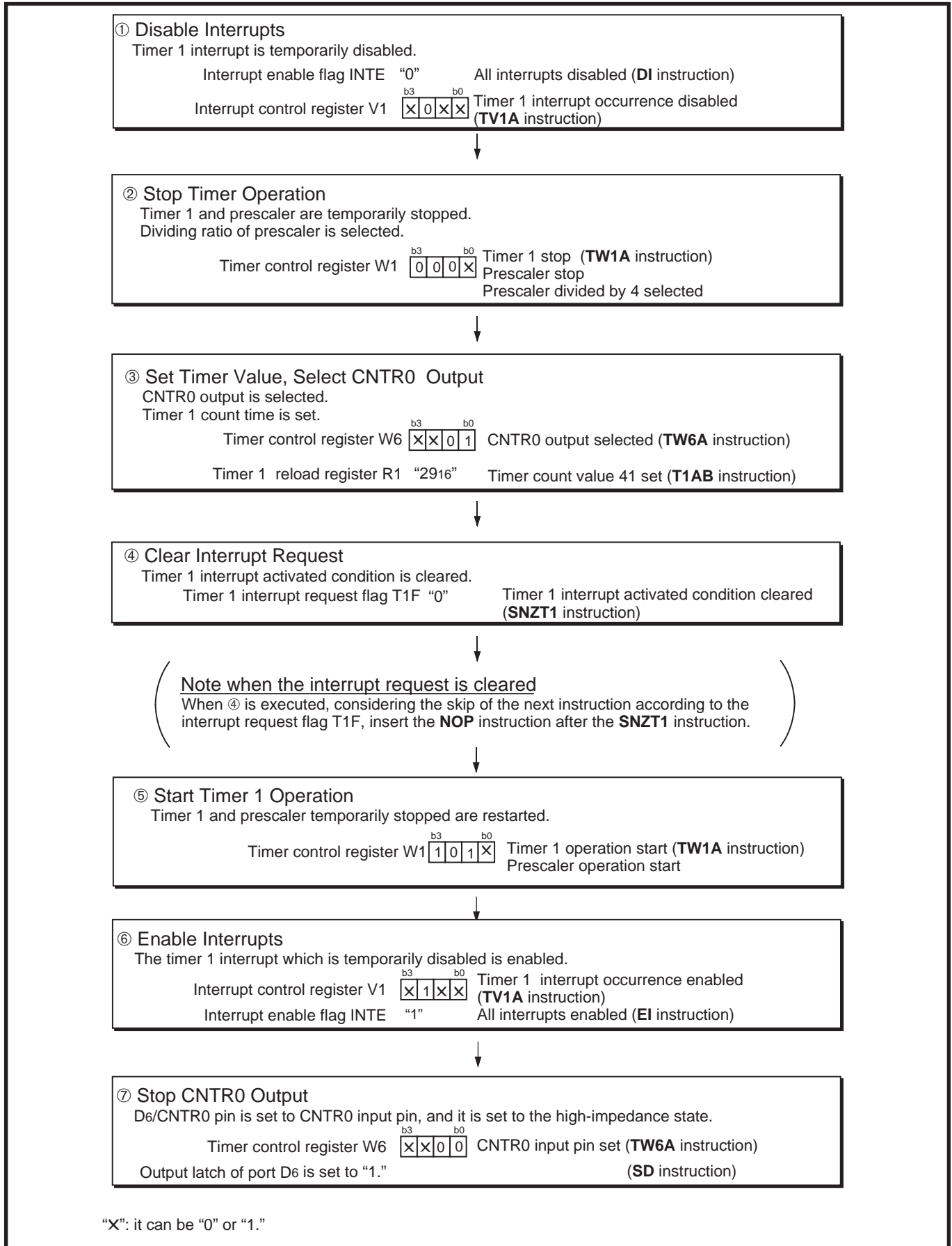

Fig. 2.3.4 CNTR0 output setting example

APPLICATION

2.3 Timers

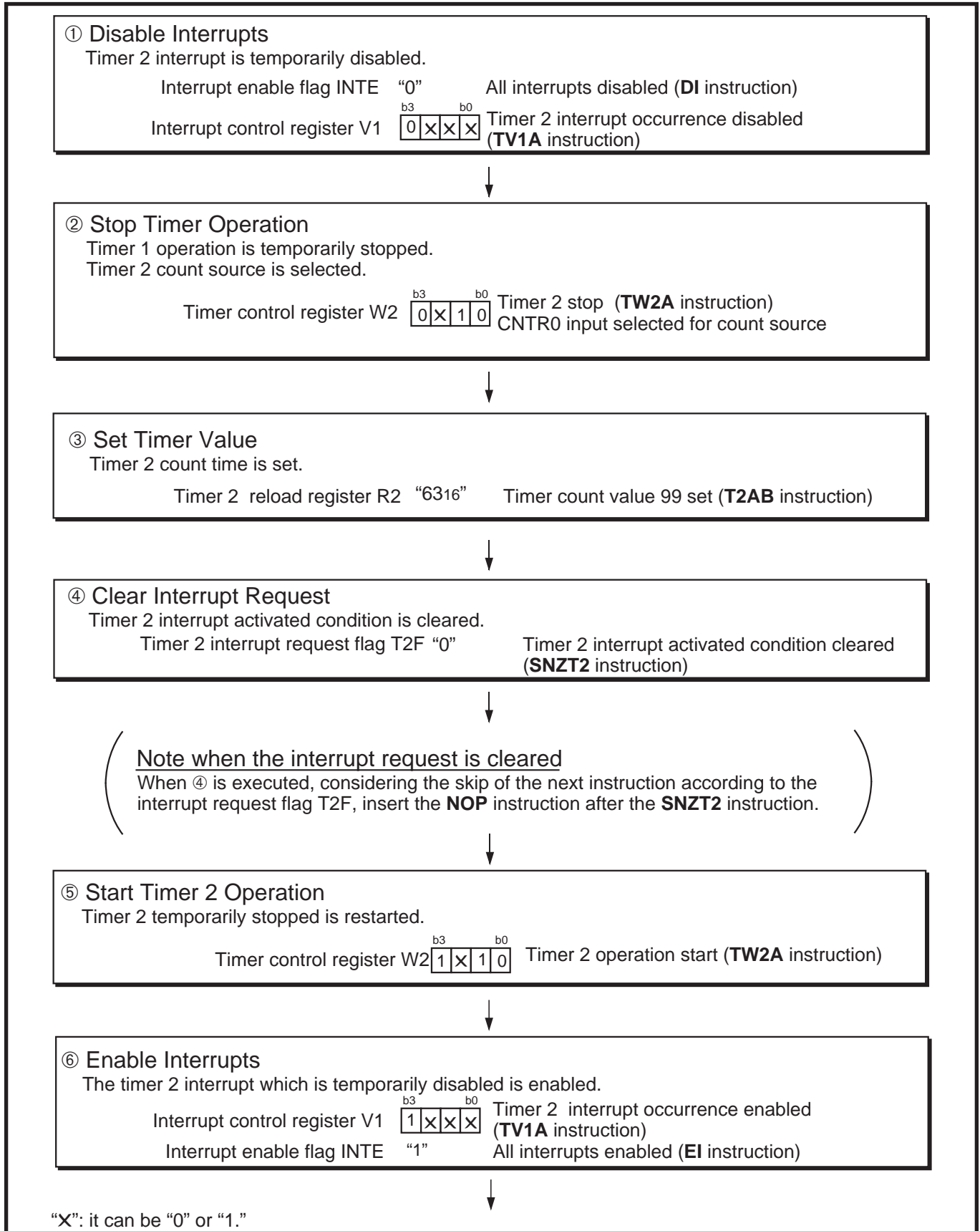

Fig. 2.3.5 CNTR1 input setting example

However, specify the pulse width input to CNTR0 pin/CNTR1 pin. Refer to section "2.3.4 Notes on use" for the timer external input period condition.

① Disable Interrupts

Timer 3 and timer 4 interrupt are temporarily disabled.

Interrupt enable flag INTE "0" All interrupts disabled (**DI** instruction)

Interrupt control register V2 $\begin{matrix} b3 & & b0 \\ \boxed{X} & \boxed{X} & \boxed{0} & \boxed{0} \end{matrix}$ Timer 3 and timer 4 interrupt occurrence disabled (**TV2A** instruction)



② Stop Timer Operation

Timer is temporarily stopped.
Dividing ratio of prescaler is selected.
Timer 3 count source is selected.
Timer 4 count source is selected.

Timer control register W3 $\begin{matrix} b3 & & b0 \\ \boxed{0} & \boxed{X} & \boxed{0} & \boxed{1} \end{matrix}$ Timer 3 stop (**TW3A** instruction)
Prescaler selected for count source

Timer control register W4 $\begin{matrix} b3 & & b0 \\ \boxed{0} & \boxed{X} & \boxed{0} & \boxed{0} \end{matrix}$ Timer 4 stop (**TW4A** instruction)
Timer 3 underflow selected for count source

Timer control register W1 $\begin{matrix} b3 & & b0 \\ \boxed{1} & \boxed{0} & \boxed{X} & \boxed{X} \end{matrix}$ Instruction clock divided by 4 selected (**TW1A** instruction)



③ Set Timer Value, Select CNTR1 Output

CNTR1 output is selected.
Timer 3 and timer 4 count time are set.

Timer control register W6 $\begin{matrix} b3 & & b0 \\ \boxed{1} & \boxed{1} & \boxed{X} & \boxed{X} \end{matrix}$ CNTR1 output selected (**TW6A** instruction)

Timer 3 reload register R3 "2916" Timer count value 41 set (**T3AB** instruction)

Timer 3 reload register R4 "FF16" Timer count value 255 set (**T4AB** instruction)



④ Start Timer Operation

Timer 3 and timer 4 temporarily stopped are restarted.

Timer control register W3 $\begin{matrix} b3 & & b0 \\ \boxed{1} & \boxed{X} & \boxed{0} & \boxed{1} \end{matrix}$ Timer 3 operation start (**TW3A** instruction)

Timer control register W4 $\begin{matrix} b3 & & b0 \\ \boxed{1} & \boxed{X} & \boxed{0} & \boxed{0} \end{matrix}$ Timer 4 operation start (**TW4A** instruction)



⑤ Enable Interrupts

Interrupt enable flag INTE "1" All interrupts enabled (**EI** instruction)



"X": it can be "0" or "1."

Fig. 2.3.6 CNTR0 output control setting example

APPLICATION

2.3 Timers

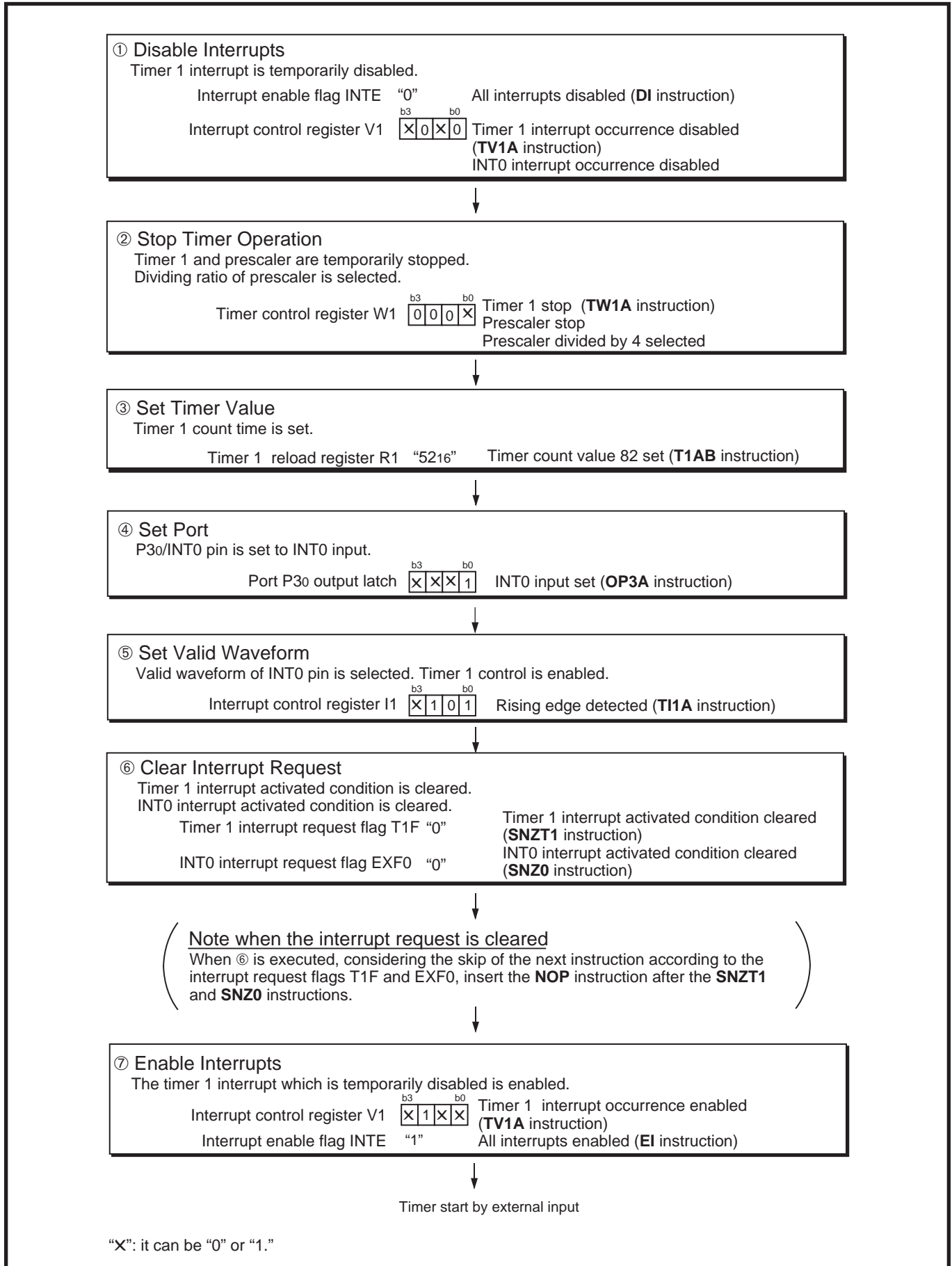

Fig. 2.3.7 Timer start by external input setting example (1)

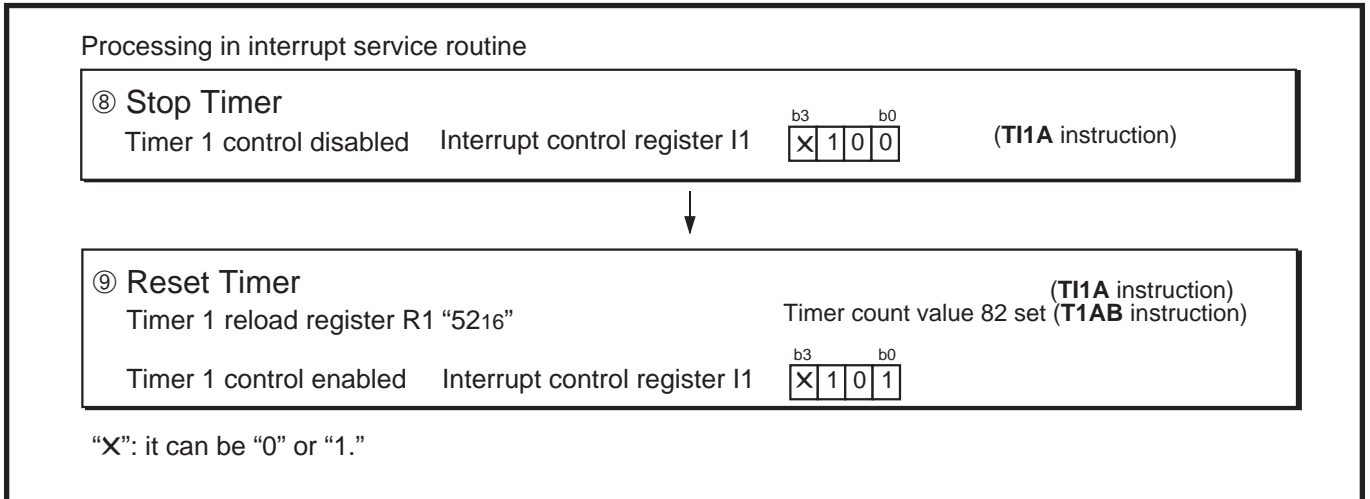

Fig. 2.3.8 Timer start by external input setting example (2)

APPLICATION

2.3 Timers

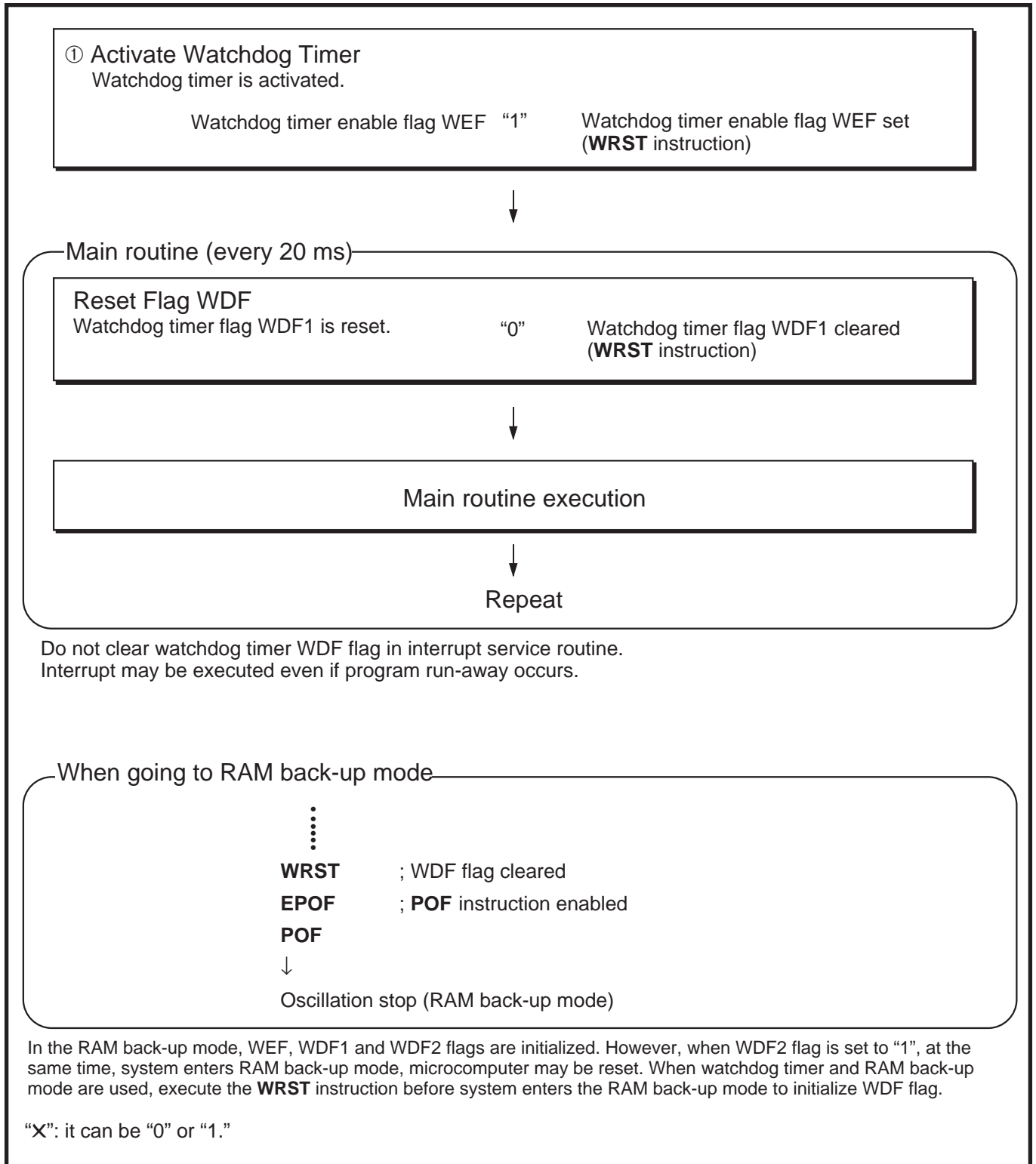

Fig. 2.3.9 Watchdog timer setting example

2.3.4 Notes on use

(1) Prescaler

Stop the prescaler operation to change its frequency dividing ratio.

(2) Count source

Stop timer 1, 2, 3, or 4 counting to change its count source.

(3) Reading the count values

Stop timer 1, 2, 3, or 4 counting and then execute the **TAB1**, **TAB2**, **TAB3**, or **TAB4** instruction to read its data.

(4) Writing to reload registers R1, R3

When writing data to reload registers R1, R3 while timer 1 and 3 are operating, avoid a timing when timers 1 and 3 underflow.

2.4.2 Related registers

(1) Serial I/O register SI

Serial I/O register SI is the 8-bit data transfer serial/parallel conversion register. Data can be set to register SI through registers A and B with the **TSIAB** instruction.

(2) Serial I/O mode register J1

Serial I/O synchronous clock selection bit is assigned to bit 0, serial I/O port selection bit is assigned to bit 1 and serial I/O internal clock dividing ratio selection bit is assigned to bit 2.

Set the contents of this register through register A with the **TJ1A** instruction. The **TAJ1** instruction can be used to transfer the contents of register J1 to register A.

Table 2.4.1 shows the serial I/O mode register J1.

Table 2.4.1 Serial I/O mode register J1

Serial I/O mode register J1		at reset : 0000 ₂	at RAM back-up : state retained	R/W
J13	Not used	0	This bit has no function, but read/write is enabled.	
		1		
J12	Serial I/O internal clock dividing ratio selection bit	0	Instruction clock signal divided by 8	
		1	Instruction clock signal divided by 4	
J11	Serial I/O port selection bit	0	Input ports P20, P21, P22 selected	
		1	Serial I/O ports SCK, SOUT, SIN/input ports P20, P21, P22 selected	
J10	Serial I/O synchronous clock selection bit	0	External clock	
		1	Internal clock (instruction clock divided by 4 or 8)	

Note: “R” represents read enabled, and “W” represents write enabled.

(3) Serial I/O transmission/reception completion flag (SIOF)

Serial I/O transmission/reception completion flag (SIOF) is set to “1” when serial data transmission or reception completes. The state of SIOF flag can be examined with the skip instruction (**SNZSI**).

APPLICATION

2.4 Serial I/O

2.4.3 Operation description

Figure 2.4.2 shows the serial I/O connection example, Figure 2.4.3 shows the serial I/O register state, and Figure 2.4.4 shows the serial I/O transfer timing.

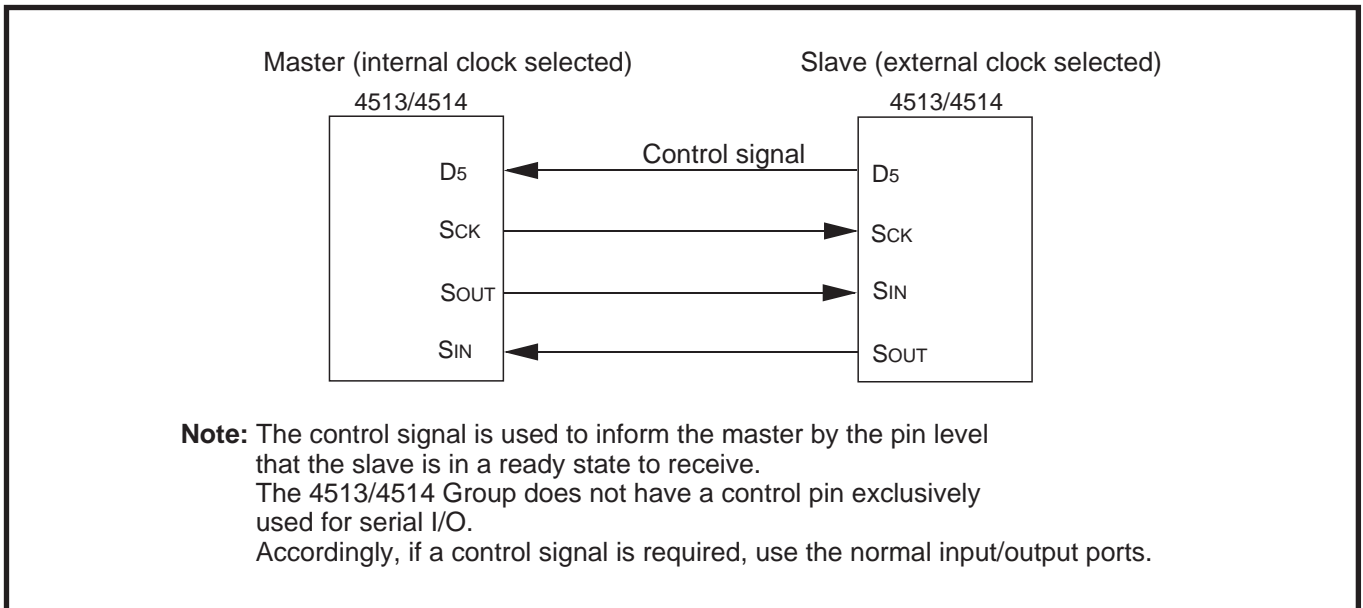

Fig. 2.4.2 Serial I/O connection example

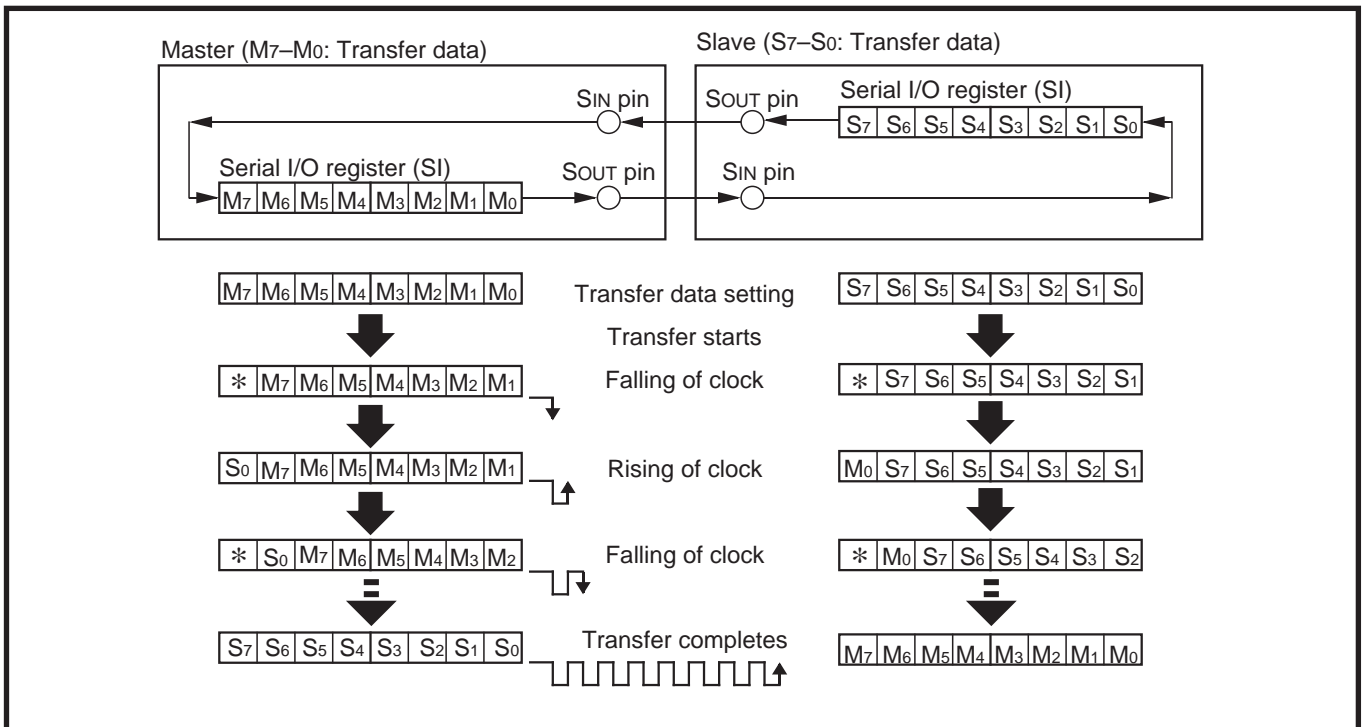

Fig. 2.4.3 Serial I/O register state when transmitting/receiving

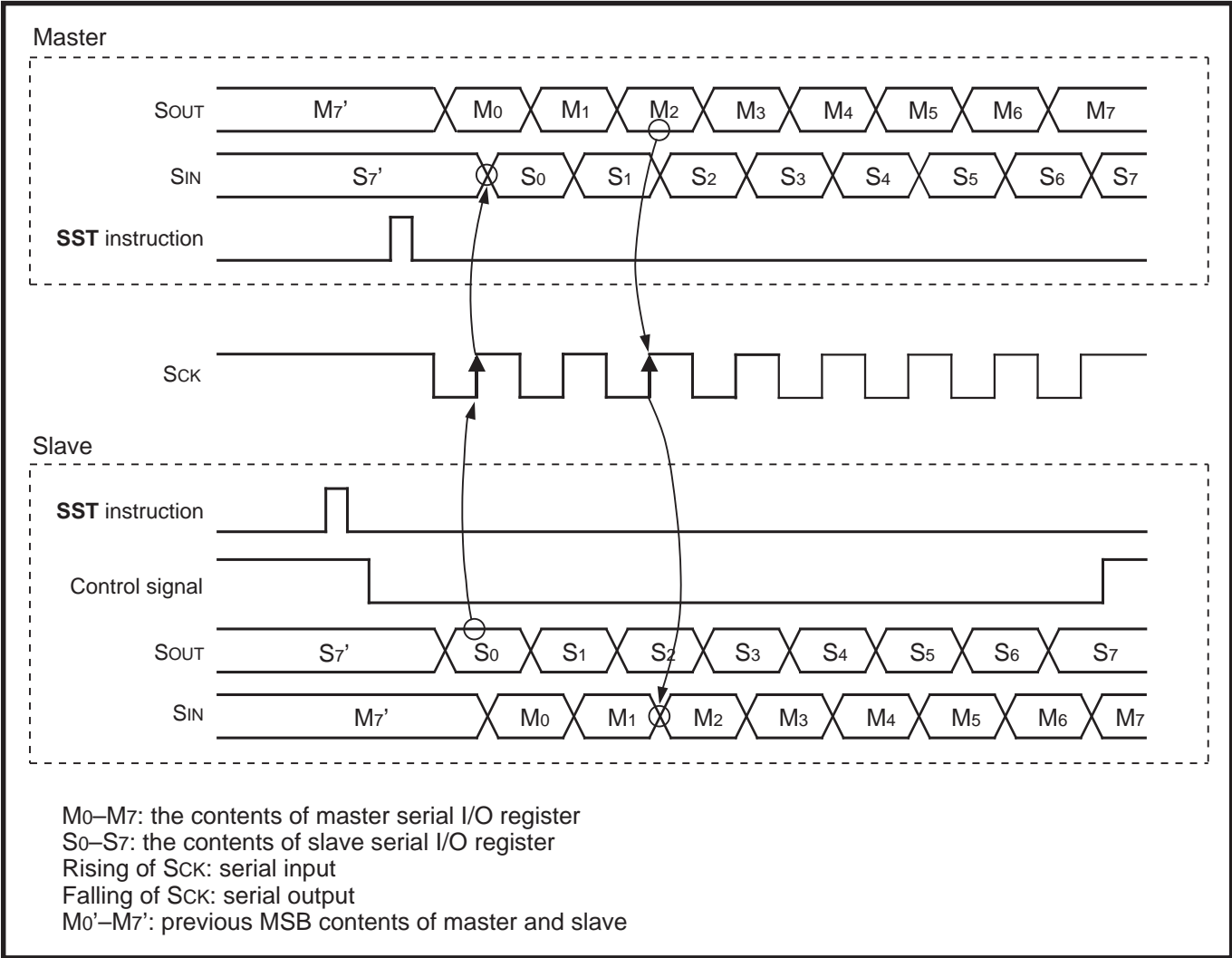

Fig. 2.4.4 Serial I/O transfer timing

APPLICATION

2.4 Serial I/O

The full duplex communication of master and slave is described using the connection example shown in Figure 2.4.2.

(1) Transmit/receive operation of master

- ① The transmit data is written into the serial I/O register SI with the **TSIAB** instruction. When the **TSIAB** instruction is executed, the contents of register A are transferred to the low-order 4 bits of register SI and the contents of register B are transferred to the high-order 4 bits of register SI.
- ② Whether the microcomputer on the receiving side is ready to receive or not is checked. In the connection example in Figure 2.4.2, check that the input level of control signal is “L” level.
- ③ Serial transfer is started with the **SST** instruction.
When the **SST** instruction is executed, the serial I/O transmit/receive completion flag (SIOF) is cleared to “0.”
- ④ The transmit data is output from the SOUT pin synchronously with the falling edges of the shift clock.
- ⑤ The transmit data is output bit by bit beginning with the LSB bit of register SI. Each time one bit is output, the contents of register SI is shifted one bit position toward the LSB.
- ⑥ Also, the receive data is input from the SIN pin synchronously with the rising edges of the shift clock.
- ⑦ The receive data is input bit by bit to the MSB bit of register SI.
- ⑧ A serial I/O interrupt request occurs when the transfer of transmit data and receive data is completed, and the SIOF flag is set to “1.”
- ⑨ The receive data is taken in within the serial I/O interrupt service routine; or the data is taken in after examining the completion of the transmit/receive operation with the **SNZSI** instruction without using an interrupt.
Also, the SIOF flag is cleared to “0” when an interrupt occurs or the **SNZSI** instruction is executed.

Notes 1: Repeat steps ① through ⑨ to transmit or receive multiple data in succession.

2: For the program on the master side, make sure that transmission is not started before the control signal is released back “H” after a transmit operation is started first.

(2) Transmit/receive operation of slave

- ① The transmit data is written into the serial I/O register SI with the **TSIAB** instruction. When the **TSIAB** instruction is executed, the contents of register A are transferred to the low-order bits of register SI and the contents of register B are transferred to the high-order bits of register SI. At this time, the SCK pin must be at the “H” level.
- ② Serial transfer is started with the **SST** instruction. However, in Figure 2.4.2 where an external clock is selected, transfer is not started until the clock is input. When the **SST** instruction is executed, the serial I/O transmit/receive completion flag (SIOF) is cleared to “0.”
- ③ The microcomputer on the transmitting side is informed that the receiving side is ready to receive. In the connection example in Figure 2.4.2, this notification is done by pulling the control signal “L” level.
- ④ The transmit data is output from the SOUT pin synchronously with the falling edges of the shift clock.
- ⑤ The transmit data is output bit by bit beginning with the LSB bit of register SI. Each time one bit is output, the contents of register SI are shifted to one bit position toward the LSB.
- ⑥ Also, the receive data is input from the SIN pin synchronously with the rising edges of the shift clock.
- ⑦ The receive data is input bit by bit to the MSB bit of register SI.
- ⑧ A serial I/O interrupt request occurs when the transmit/receive of data is completed, and the SIOF flag is set to “1.”
- ⑨ The receive data is taken in within the serial I/O interrupt service routine; or the data is taken in after examining the completion of the transmit/receive operation with the **SNZSI** instruction without using an interrupt.
Also, the SIOF flag is cleared to “0” when an interrupt occurs or the **SNZSI** instruction is executed. Make sure that the control signal pin level is “H” after the receive operation is completed.

Note: Repeat steps ① through ⑨ to transmit or receive multiple data in succession.

2.4.4 Serial I/O application example**(1) Serial I/O**

Outline: The 4513/4514 Group can communicate with peripheral ICs.

Specifications: Figure 2.4.2 Serial I/O connection example.

Figure 2.4.5 shows the master serial I/O setting example, and Figure 2.4.6 shows the slave serial I/O setting example.

APPLICATION

2.4 Serial I/O

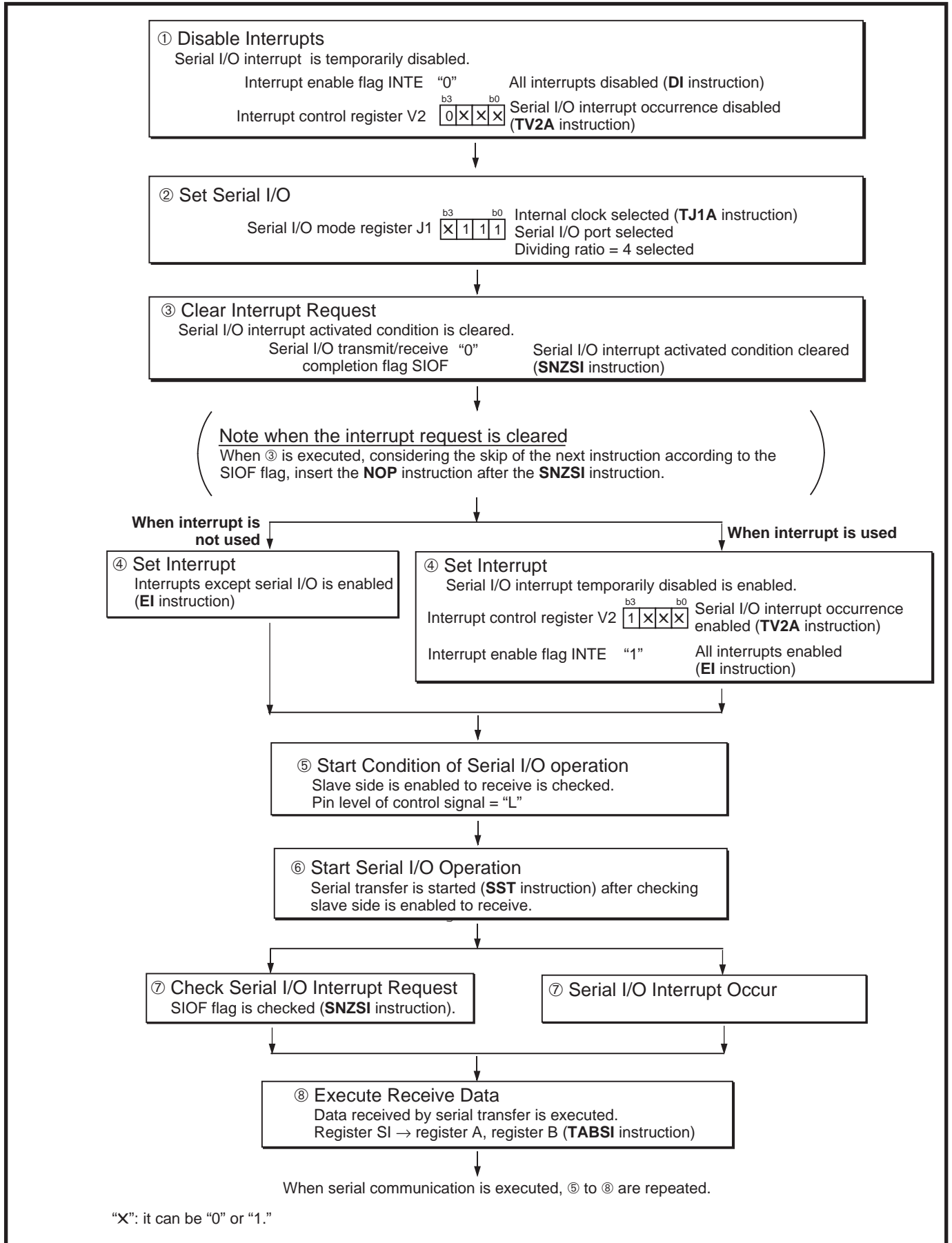

Fig. 2.4.5 Master serial I/O setting example

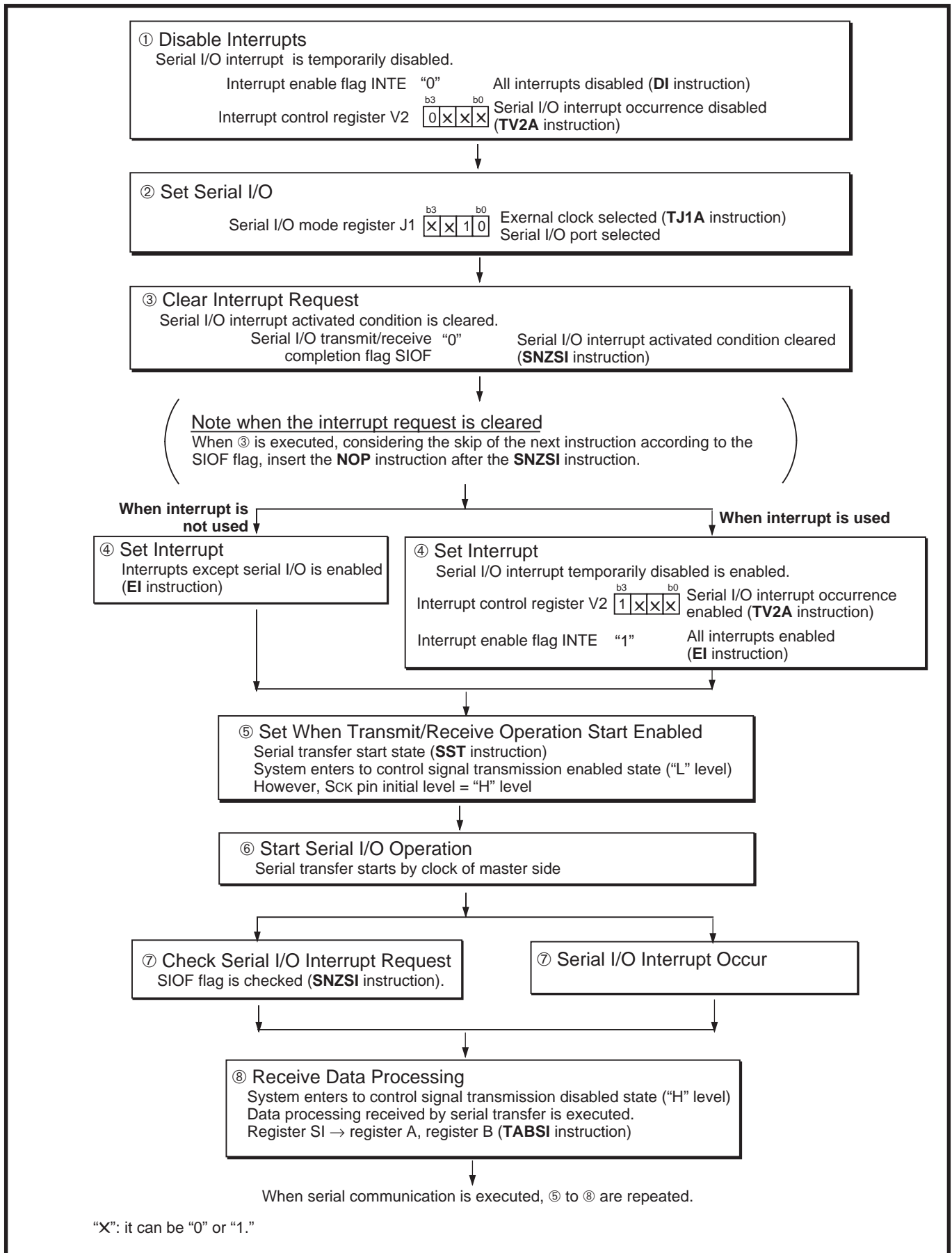

Fig. 2.4.6 Slave serial I/O example

APPLICATION

2.4 Serial I/O

2.4.5 Notes on use

(1) Note when an external clock is used as a synchronous clock:

- An external clock is selected as the synchronous clock, the clock is not controlled internally.
- Serial transfer is continued as long as an external clock is input. If an external clock is input 9 times or more and serial transfer is continued, the receive data is transferred directly as transmit data, so that be sure to control the clock externally.
Note also that the SIOF flag is set when a clock is counted 8 times.
- Make sure that the initial input level on the external clock pin is always “H” level.
- Table 2.4.2 shows the recommended operating conditions when using serial I/O with an external clock. Figure 2.4.7 shows an input waveform of external clock.

Table 2.4.2 Recommended operating conditions (serial I/O)

Parameter	Condition		Limits			Unit
			Min.	Typ.	Max.	
Serial I/O external clock period (Note 1)	Middle-speed mode	VDD = 4.0 V to 5.5 V	1.5			μs
		VDD = 2.5 V to 5.5 V	3.0			
		VDD = 2.0 V to 5.5 V (Note 2)	4.0			
	High-speed mode	VDD = 4.0 V to 5.5 V	750			ns
		VDD = 2.5 V to 5.5 V	1.5			μs
		VDD = 2.0 V to 5.5 V (Note 2)	2.0			

Notes 1: Limits shown in Table 2.4.2 represent the pulse widths of “H” and “L.”
2: It is effective only for mask version.

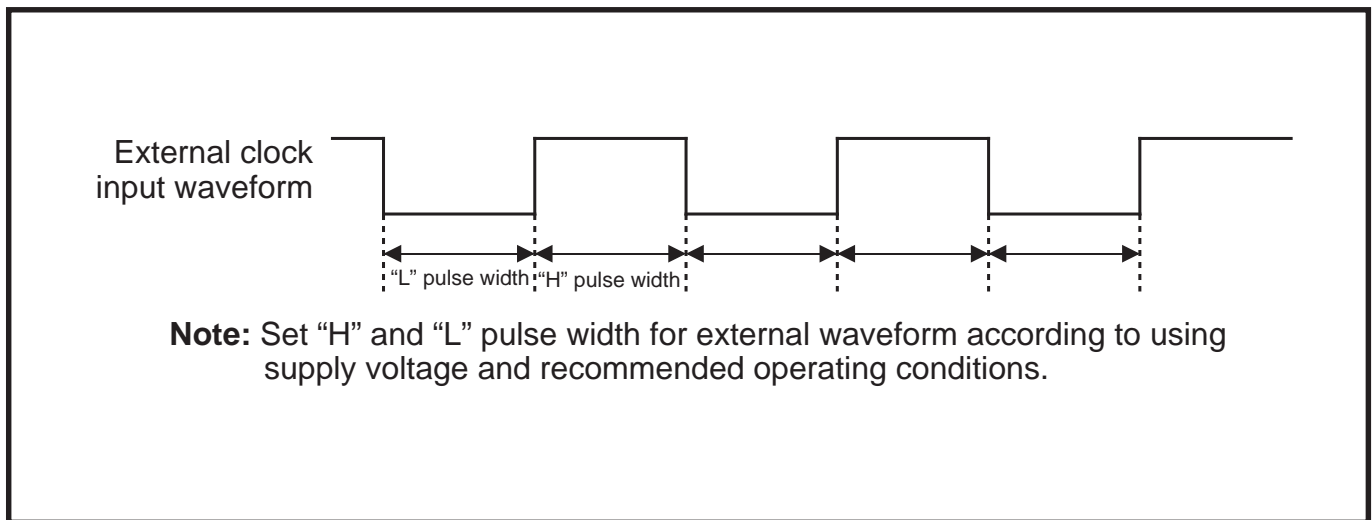

Fig. 2.4.7 Input waveform of external clock

APPLICATION

2.5 A-D converter

2.5.1 Related registers

(1) A-D control register Q1

Analog input pin selection bits are assigned to register Q1.

Set the contents of this register through register A with the **TQ1A** instruction. The **TAQ1** instruction can be used to transfer the contents of register Q1 to register A.

Table 2.5.1 shows the A-D control register Q1.

Table 2.5.1 A-D control register Q1

A-D control register Q1		at reset : 00002		at power down : state retained		R/W
Q13	Not used	0	This bit has no function, but read/write is enabled.			
		1				
Q12	Analog input pin selection bits (Note 2)	Q12	Q11	Q10	Selected pin	
		0	0	0	AIN0	
		0	0	1	AIN1	
Q11		0	1	0	AIN2	
		0	1	1	AIN3	
Q10		1	0	0	AIN4 (Not available for 4513 Group)	
		1	0	1	AIN5 (Not available for 4513 Group)	
		1	1	0	AIN6 (Not available for 4513 Group)	
		1	1	1	AIN7 (Not available for 4513 Group)	

Notes 1: "R" represents read enabled, and "W" represents write enabled.

2: Select AIN4–AIN7 with register Q1 after setting register Q2.

(2) A-D control register Q2

Analog input pin selection bits and A-D operation mode control bit are assigned to register Q2.

Set the contents of this register through register A with the **TQ2A** instruction. The **TAQ2** instruction can be used to transfer the contents of register Q2 to register A.

Table 2.5.2 shows the A-D control register Q2.

Table 2.5.2 A-D control register Q2

A-D control register Q2		at reset : 00002		at power down : state retained		R/W
Q23	A-D operation mode control bit	0	A-D conversion mode			
		1	Comparator mode			
Q22	P43/AIN7, P42/AIN6 pin function selection bit (Note 3)	0	P43, P42 (I/O) (Note 4)			
		1	AIN7, AIN6/P43, P42 (Output) (Note 4)			
Q21	P41/AIN5 pin function selection bit (Note 3)	0	P41 (I/O) (Note 4)			
		1	AIN5/P41 (Output) (Note 4)			
Q20	P40/AIN4 pin function selection bit (Note 3)	0	P40 (I/O) (Note 4)			
		1	AIN4/P40 (Output) (Note 4)			

Notes 1: "R" represents read enabled, and "W" represents write enabled.

2: Select AIN4–AIN7 with register Q1 after setting register Q2.

3: In the 4513 Group, these bits are not used.

4: In the 4513 Group, only read/write of these bits is enabled.

2.5.2 A-D converter application examples

(1) A-D conversion mode

Outline: Analog input signal from a sensor can be converted into digital values.

Specifications: Analog voltage values from a sensor is converted into digital values by using a 10-bit successive comparison method. Use the AIN0 pin for this analog input.

Figure 2.5.2 shows the A-D conversion mode setting example.

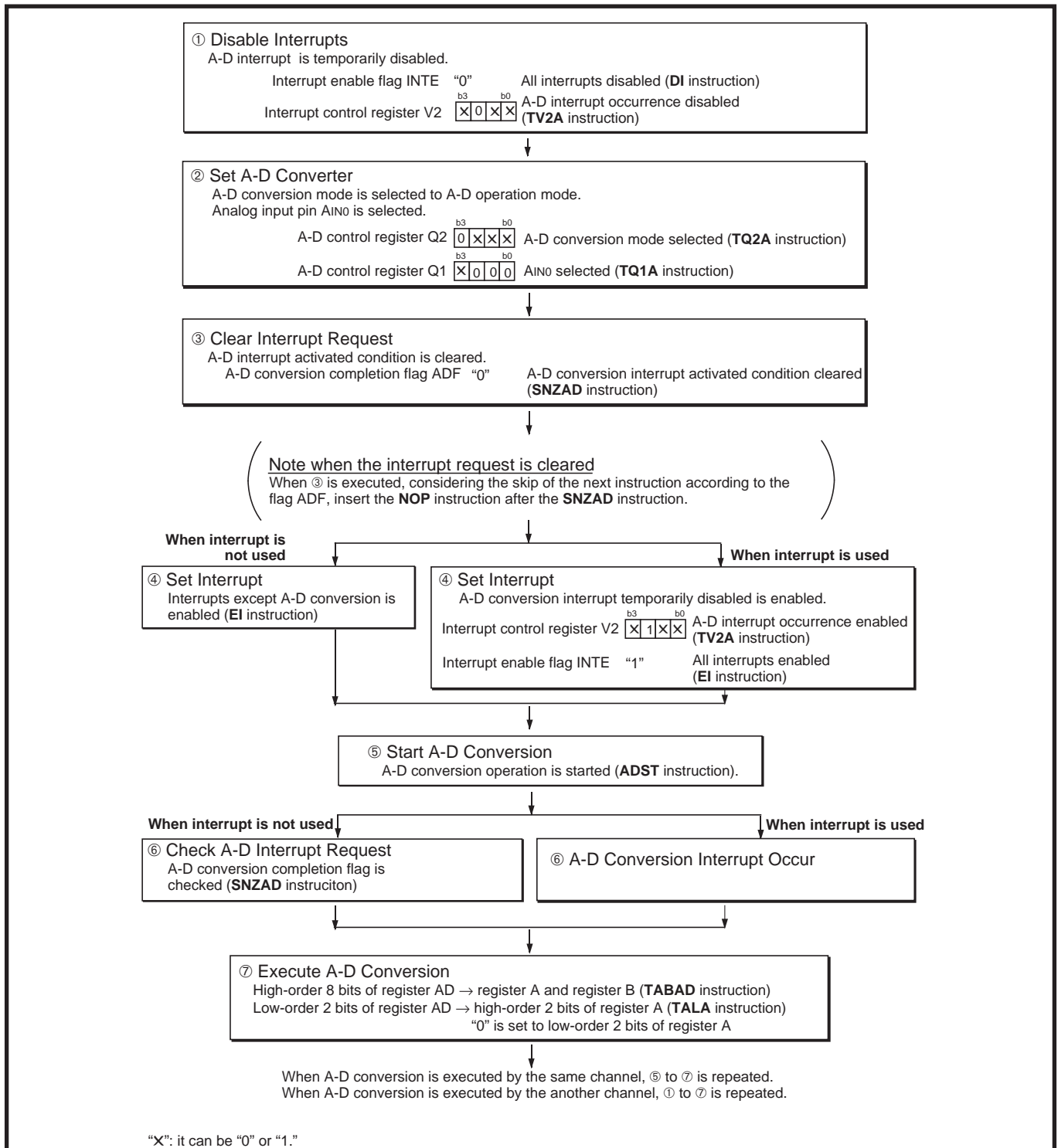

Fig. 2.5.2 A-D conversion mode setting example

APPLICATION

2.5 A-D converter

2.5.3 Notes on use

(1) Note when the A-D conversion starts again

When the A-D conversion starts again with the **ADST** instruction during A-D conversion, the previous input data is invalidated and the A-D conversion starts again.

(2) A-D control register Q2

Select AIN4–AIN7 with register Q1 after setting register Q2.

(3) A-D converter-1

Each analog input pin is equipped with a capacitor which is used to compare the analog voltage. Accordingly, when the analog voltage is input from the circuit with high-impedance and, charge/discharge noise is generated and the sufficient A-D accuracy may not be obtained. Therefore, reduce the impedance or, connect a capacitor (0.01 μ F to 1 μ F) to analog input pins.

Figure 2.5.3 shows the analog input external circuit example-1.

When the overvoltage applied to the A-D conversion circuit may occur, connect an external circuit in order to keep the voltage within the rated range as shown the Figure 2.5.4. In addition, test the application products sufficiently.

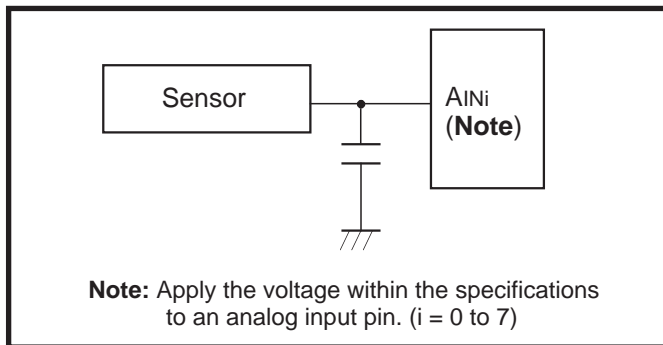

Fig. 2.5.3 Analog input external circuit example-1

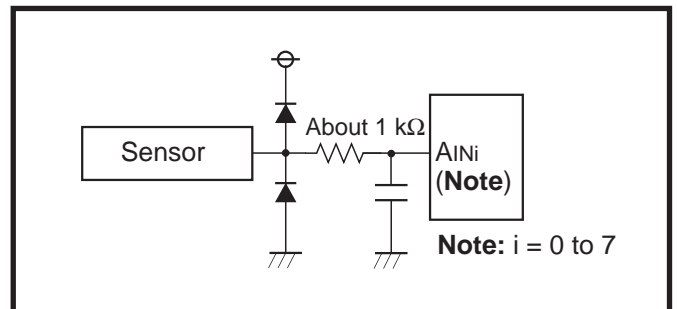

Fig. 2.5.4 Analog input external circuit example-2

(4) Notes for the use of A-D conversion 2

When the operating mode of the A-D converter is changed from the comparator mode to the A-D conversion mode with bit 3 of register Q2 in a program, be careful about the following notes.

- Clear bit 2 of register V2 to “0” to change the operating mode of the A-D converter from the comparator mode to the A-D conversion mode with bit 3 of register Q2 (refer to Figure 2.5.5①).
- The A-D conversion completion flag (ADF) may be set when the operating mode of the A-D converter is changed from the comparator mode to the A-D conversion mode. Accordingly, set a value to register Q2, and execute the **SNZAD** instruction to clear the ADF flag.

Do not change the operating mode (both A-D conversion mode and comparator mode) of A-D converter with bit 3 of register Q2 during operating the A-D converter.

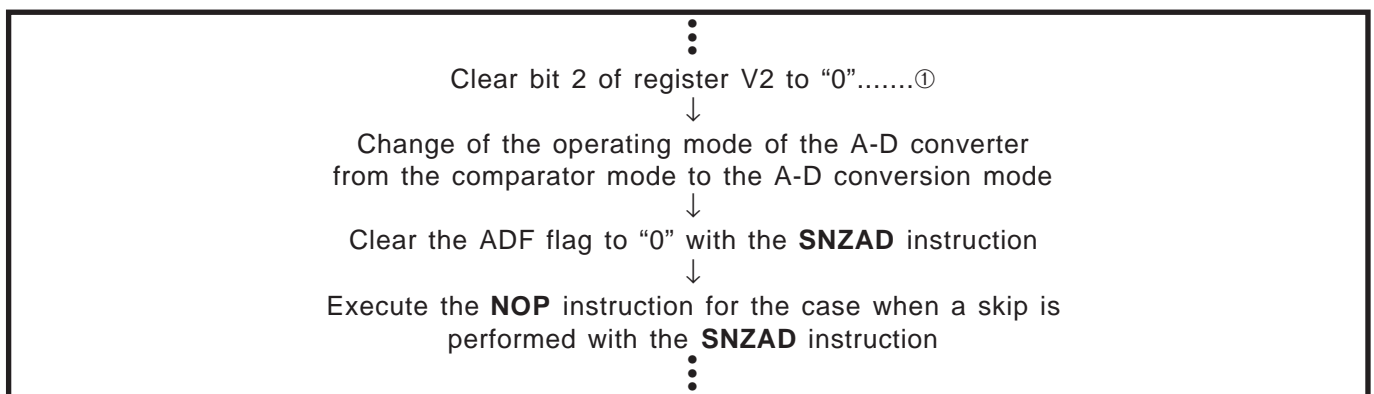

Fig. 2.5.5 A-D converter operating mode program example

(5) A-D converter is used at the comparator mode

The analog input voltage is higher than the comparison voltage as a result of comparison, the contents of ADF flag retains “0,” not set to “1.”

In this case, the A-D interrupt does not occur even when the usage of the A-D interrupt is enabled. Accordingly, consider the time until the comparator operation is completed, and examine the state of ADF flag by software. The comparator operation is completed after 8 machine cycles.

(6) Analog input pins

Even when P40/AIN4–P43/AIN7 are set to pins for analog input, they continue to function as P40–P43 I/O. Accordingly, when any of them are used as I/O port P4 and others are used as analog input pins, make sure to set the outputs of pins that are set for analog input to “1.” Also, the port input function of the pin functions as an analog input is undefined.

(7) TALA instruction

When the **TALA** instruction is executed, the low-order 2 bits of register AD is transferred to the high-order 2 bits of register A, and simultaneously, the low-order 2 bits of register A is “0.”

(8) Recommended operating conditions when using A-D converter

The recommended operating conditions of supply voltage and system clock frequency when using A-D converter are different from those when not using A-D converter.

Table 2.5.3 shows the recommended operating conditions when using A-D converter.

Table 2.5.3 Recommended operating conditions (when using A-D converter)

Parameter	Condition	Limits			Unit
		Min.	Typ.	Max.	
System clock frequency (at ceramic resonance)	VDD = 4.5 V to 5.5 V (high-speed mode)	0.4		4.2	MHz
	VDD = 4.0 V to 5.5 V (high-speed mode)	0.4		2.0	
	VDD = 2.7 V to 5.5 V (middle-speed mode)	0.4		4.2	
System clock frequency (at external clock input)	VDD = 4.5 V to 5.5 V (high-speed mode)	Duty 40 % to 60 %	0.4	3.0	
	VDD = 4.0 V to 5.5 V (high-speed mode)		0.4	1.0	
	VDD = 2.7 V to 5.5 V (middle-speed mode)		0.4	3.0	

APPLICATION

2.6 Voltage comparator

2.6 Voltage comparator

The 4513/4514 Group has two voltage comparators; CMP0-, CMP0+, CMP1-, CMP1+. This section describes the voltage comparator function, related registers, and notes.

2.6.1 Voltage comparator function

(1) **CMP0**

■ **Voltage comparison**

The voltage of CMP0- is compared with that of CMP0+, and the result is stored into bit 0 of the voltage comparator control register Q3.

(2) **CMP1**

■ **Voltage comparison**

The voltage of CMP1- is compared with that of CMP1+, and the result is stored into bit 1 of the voltage comparator control register Q3.

2.6.2 Related registers

(1) **Voltage comparator control register Q3**

The voltage comparator (CMP1) control bit is assigned to bit 3, the voltage comparator (CMP0) control bit is assigned to bit 2, the CMP1 comparison result store bit is assigned to bit 1 and the CMP0 comparison result store bit is assigned to bit 0.

Set the contents of this register through register A with the **TQ3A** instruction. The **TAQ3** instruction can be used to transfer the contents of register Q3 to register A.

Table 2.6.1 shows the voltage comparator control register Q3.

Table 2.6.1 Voltage comparator control register Q3

Voltage comparator control register Q3 (Note 2)		at reset : 00002	at RAM back-up : state retained	R/W
Q33	Voltage comparator (CMP1) control bit	0	Voltage comparator (CMP1) invalid	
		1	Voltage comparator (CMP1) valid	
Q32	Voltage comparator (CMP0) control bit	0	Voltage comparator (CMP0) invalid	
		1	Voltage comparator (CMP0) valid	
Q31	CMP1 comparison result store bit	0	CMP1- > CMP1+	
		1	CMP1- < CMP1+	
Q30	CMP0 comparison result store bit	0	CMP0- > CMP0+	
		1	CMP0- < CMP0+	

Notes 1: "R" represents read enabled, and "W" represents write enabled.

2: Bits 0 and 1 of register Q3 can be only read.

2.6.3 Notes on use

- **Voltage comparator function**

When the voltage comparator function is valid with the voltage comparator control register Q3, it is operating even in the RAM back-up mode. Accordingly, be careful about such state because it causes the increase of the operation current in the RAM back-up mode.

In order to reduce the operation current in the RAM back-up mode, invalidate (bits 2 and 3 of register Q3 = "0") the voltage comparator function by software before the **POF** instruction is executed.

Also, while the voltage comparator function is valid, current is always consumed by voltage comparator. On the system required for the low-power dissipation, invalidate the voltage comparator when it is unused by software.

- **Register Q3**

Bits 0 and 1 of register Q3 can be only read. Note that they cannot be written.

- **Reading the comparison result of voltage comparator**

Read the voltage comparator comparison result from register Q3 after the voltage comparator response time (max. 20 μ s) is passed from the voltage comparator function become valid.

APPLICATION

2.7 Reset

2.7 Reset

System reset is performed by applying “L” level to the $\overline{\text{RESET}}$ pin for 1 machine cycle or more when the following conditions are satisfied:

- the value of supply voltage is the minimum value or more of the recommended operating conditions
- oscillation is stabilized.

Then when “H” level is applied to $\overline{\text{RESET}}$ pin, the software starts from address 0 in page 0 after elapsing of the internal oscillation stabilizing time ($f(\text{XIN})$ is counted for 16892 to 16895 machine cycles). Figure 2.7.2 shows the oscillation stabilizing time.

2.7.1 Reset circuit

The 4513/4514 Group has the power-on reset circuit and voltage drop detection circuit.

(1) Power-on reset

Reset can be performed automatically at power on (power-on reset) by connecting resistors, a diode, and a capacitor to $\overline{\text{RESET}}$ pin. Connect a capacitor between the $\overline{\text{RESET}}$ pin and VSS at the shortest distance.

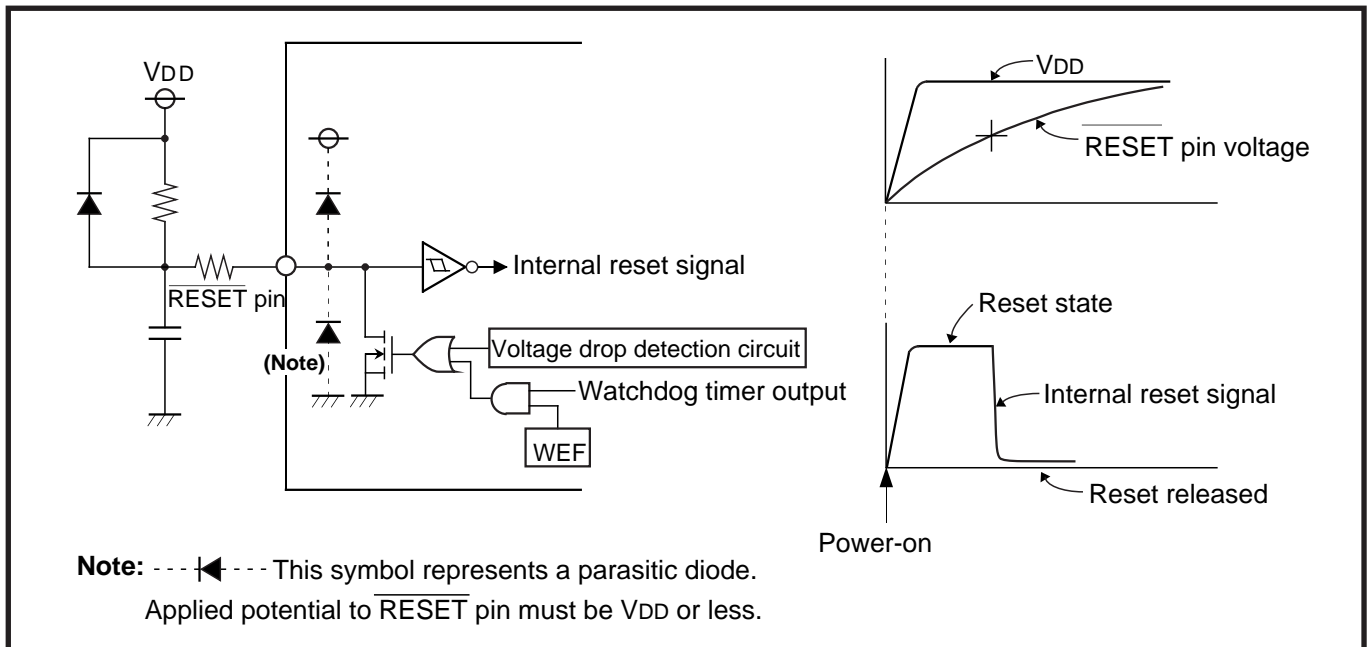

Fig. 2.7.1 Power-on reset circuit example

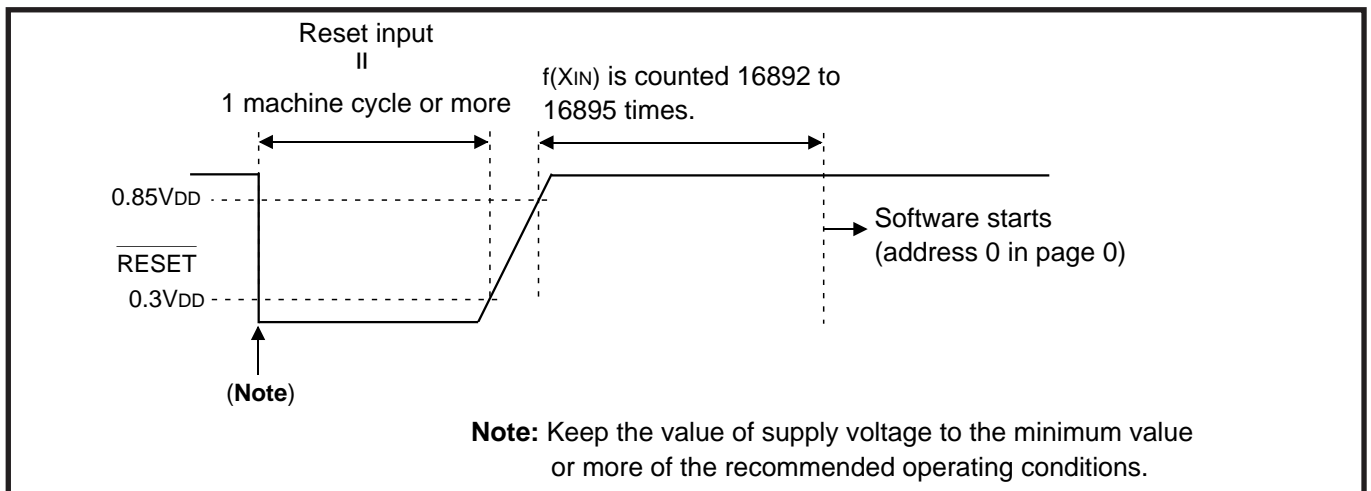

Fig. 2.7.2 Oscillation stabilizing time after system is released from reset

2.7.2 Internal state at reset

Figure 2.7.3 shows the internal state at reset. The contents of timers, registers, flags and RAM other than shown in Figure 2.7.3 are undefined, so that set them to initial values.

• Program counter (PC)	0 0 0 0 0 0 0 0 0 0 0 0 0 0 0 0	
Address 0 in page 0 is set to program counter.		
• Interrupt enable flag (INTE)	0	(Interrupt disabled)
• Power down flag (P)	0	
• External 0 interrupt request flag (EXF0)	0	
• External 1 interrupt request flag (EXF1)	0	
• Interrupt control register V1	0 0 0 0	(Interrupt disabled)
• Interrupt control register V2	0 0 0 0	(Interrupt disabled)
• Interrupt control register I1	0 0 0 0	
• Interrupt control register I2	0 0 0 0	
• Timer 1 interrupt request flag (T1F)	0	
• Timer 2 interrupt request flag (T2F)	0	
• Timer 3 interrupt request flag (T3F)	0	
• Timer 4 interrupt request flag (T4F)	0	
• Watchdog timer flags (WDF1, WDF2)	0	
• Watchdog timer enable flag (WEF)	0	
• Timer control register W1	0 0 0 0	(Prescaler, timer 1 stopped)
• Timer control register W2	0 0 0 0	(Timer 2 stopped)
• Timer control register W3	0 0 0 0	(Timer 3 stopped)
• Timer control register W4	0 0 0 0	(Timer 4 stopped)
• Timer control register W6	0 0 0 0	
• Clock control register MR	1 0 0 0	
• Serial I/O transmit/receive completion flag	0	
• Serial I/O mode register J1	0 0 0 0	(External clock selected, serial I/O port not selected))
• Serial I/O register SI	X X X X X X X X X	
• A-D conversion completion flag ADF	0	
• A-D control register Q1	0 0 0 0	
• A-D control register Q2	0 0 0 0	
• Voltage comparator control register Q3	0 0 0 0	
• Successive comparison register AD	X X X X X X X X X X	
• Comparator register	X X X X X X X X X	
• Key-on wakeup control register K0	0 0 0 0	
• Pull-up control register PU0	0 0 0 0	
• Direction register FR0	0 0 0 0	(Port P5 input mode)
• Carry flag (CY)	0	
• Register A	0 0 0 0	
• Register B	0 0 0 0	
• Register D	X X X	
• Register E	X X X X X X X X X	
• Register X	0 0 0 0	
• Register Y	0 0 0 0	
• Register Z	X X	
• Stack pointer (SP)	1 1 1	

“X” represents undefined.

Fig. 2.7.3 Internal state at reset

APPLICATION

2.8 Voltage drop detection circuit

2.8 Voltage drop detection circuit

The built-in voltage drop detection circuit is designed to detect a drop in voltage and to reset the microcomputer if the supply voltage drops below a set value.

Figure 2.8.1 shows the voltage drop detection reset circuit, and Figure 2.8.2 shows the operation waveform example of the voltage drop detection circuit.

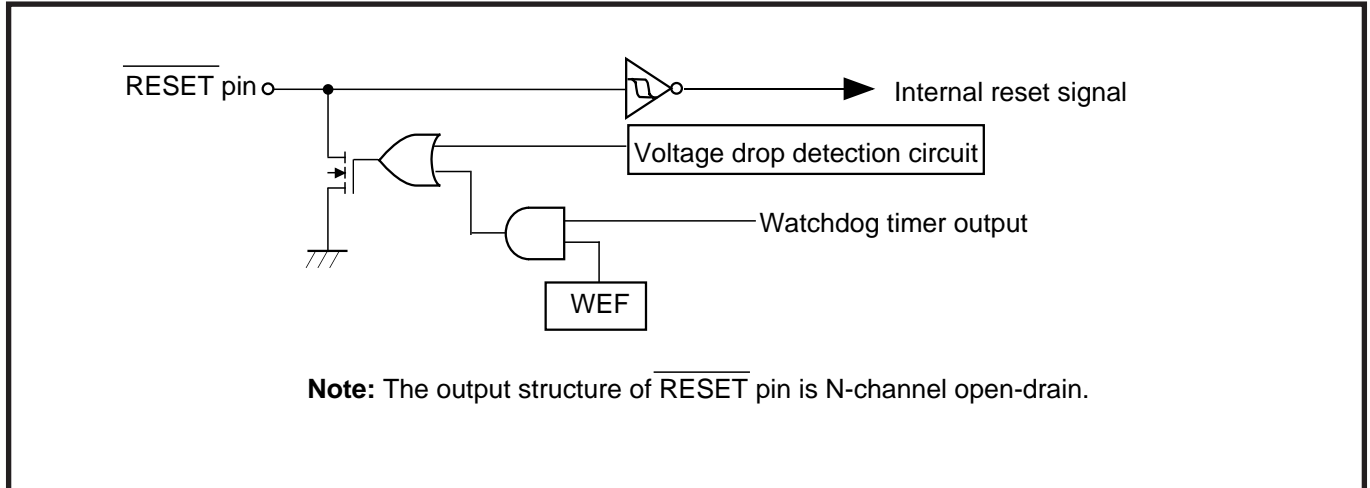

Fig. 2.8.1 Voltage drop detection reset circuit

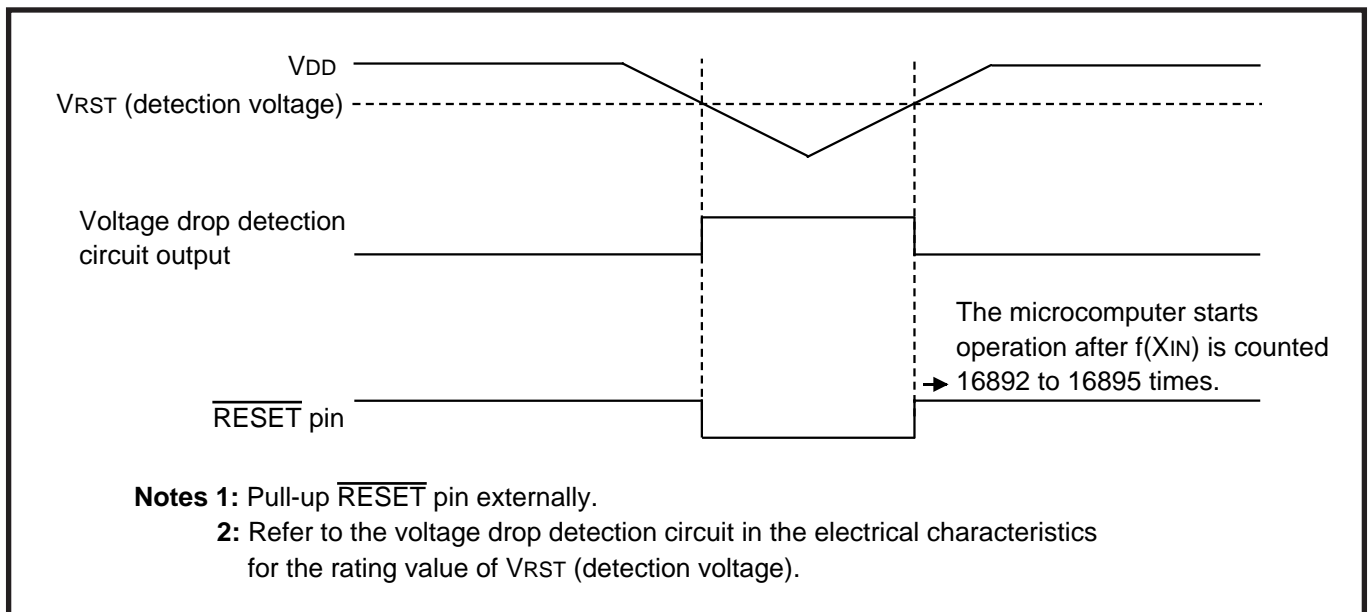

Fig. 2.8.2 Voltage drop detection circuit operation waveform

Note: Refer to section “3.1 Electrical characteristics” for the reset voltage of the voltage drop detection circuit.

2.9 RAM back-up

2.9.1 RAM back-up mode

The system enters RAM back-up mode when the **POF** instruction is executed after the **EPOF** instruction is executed. Table 2.9.1 shows the function and state retained at RAM back-up mode. Also, Table 2.9.2 shows the return source from this state.

(1) RAM back-up mode

As oscillation stops with RAM, the state of reset circuit retained, current dissipation can be reduced without losing the contents of RAM.

Table 2.9.1 Functions and states retained at RAM back-up mode

Function	RAM back-up	Function	RAM back-up
Program counter (PC), registers A, B, carry flag (CY), stack pointer (SP) (Note 2)	X	Pull-up control register PU0	O
Contents of RAM	O	Key-on wakeup control register K0	O
Port level	O	Direction register FR0	O
Timer control register W1	X	External 0 interrupt request flag (EXF0)	X
Timer control registers W2 to W4, W6	O	External 1 interrupt request flag (EXF1)	X
Clock control register MR	X	Timer 1 interrupt request flag (T1F)	X
Interrupt control registers V1, V2	X	Timer 2 interrupt request flag (T2F)	(Note 3)
Interrupt control registers I1, I2	O	Timer 3 interrupt request flag (T3F)	(Note 3)
Timer 1 function	X	Timer 4 interrupt request flag (T4F)	(Note 3)
Timer 2 function	(Note 3)	Watchdog timer flags (WDF1, WDF2)	X (Note 4)
Timer 3 function	(Note 3)	Watchdog timer enable flag (WEF)	X (Note 4)
Timer 4 function	(Note 3)	16-bit timer (WDT)	X (Note 4)
A-D function	X	A-D conversion completion flag (ADF)	X
A-D control registers Q1, Q2	O	Serial I/O transmit/receive completion flag (SIOF)	X
Voltage comparator function	O (Note 5)	Interrupt enable flag (INTE)	X
Voltage comparator control register Q3	O		
Serial I/O function	X		
Serial I/O mode register J1	O		

Notes 1: "O" represents that the function can be retained, and "X" represents that the function is initialized.

Registers and flags other than the above are undefined at RAM back-up, and set an initial value after returning.

2: The stack pointer (SP) points the level of the stack register and is initialized to "7" at RAM back-up.

3: The state of the timer is undefined.

4: Initialize the watchdog timer with the **WRST** instruction, and then execute the **POF** instruction.

5: The state is retained when the voltage comparator function is selected with the voltage comparator control register Q3.

APPLICATION

2.9 RAM back-up

Table 2.9.2 Return source and return condition

Return source		Return condition	Remarks
External wakeup signal	Ports P0, P1	Return by an external falling edge input (“H”→“L”).	Set the port using the key-on wakeup function selected with register K0 to “H” level before going into the RAM back-up state because the port P0 shares the falling edge detection circuit with port P1.
	Port P30/INT0	Return by an external “H” level or “L” level input. The EXF0 flag is not set.	Select the return level (“L” level or “H” level) with the bit 2 of register I1 according to the external state before going into the RAM back-up state.
	Port P31/INT1	Return by an external “H” level or “L” level input. The EXF1 flag is not set.	Select the return level (“L” level or “H” level) with the bit 2 of register I2 according to the external state before going into the RAM back-up state.

(2) Start condition identification

When system returns from both RAM back-up mode and reset, software is started from address 0 in page 0.

The start condition (warm start or cold start) can be identified by examining the state of the power down flag (P) with the **SNZP** instruction.

Table 2.9.3 Start condition identification

Return condition	P flag
External wakeup signal input	1
Reset	0

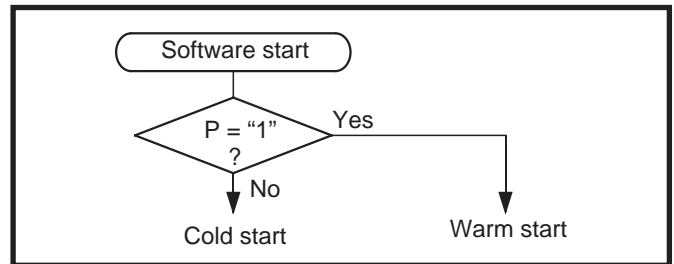

Fig. 2.9.1 Start condition identified example

2.9.2 Related register

(1) Key-on wakeup control register K0

Key-on wakeup control register K0 controls key-on wakeup functions of ports P00–P03, P10–P13.

Set the contents of this register through register A with the **TK0A** instruction. The **TAK0** instruction can be used to transfer the contents of register K0 to register A.

Table 2.9.4 shows the key-on wakeup control register K0.

Table 2.9.4 Key-on wakeup control register K0

Key-on wakeup control register K0		at reset : 00002	at RAM back-up : state retained	R/W
K03	Pins P12 and P13 key-on wakeup control bit	0	Key-on wakeup not used	
		1	Key-on wakeup used	
K02	Pins P10 and P11 key-on wakeup control bit	0	Key-on wakeup not used	
		1	Key-on wakeup used	
K01	Pins P02 and P03 key-on wakeup control bit	0	Key-on wakeup not used	
		1	Key-on wakeup used	
K00	Pins P00 and P01 key-on wakeup control bit	0	Key-on wakeup not used	
		1	Key-on wakeup used	

Note: “R” represents read enabled, and “W” represents write enabled.

(2) Pull-up control register PU0

Pull-up control register PU0 controls the pull-up functions of ports P00–P03, P10–P13.

Set the contents of this register through register A with the **TPU0A** instruction. The **TAPU0** instruction can be used to transfer the contents of register PU0 to register A.

Table 2.9.5 shows the pull-up control register PU0.

Table 2.9.5 Pull-up control register PU0

Pull-up control register PU0		at reset : 00002	at RAM back-up : state retained	R/W
PU03	Pins P12 and P13 pull-up transistor control bit	0	Pull-up transistor OFF	
		1	Pull-up transistor ON	
PU02	Pins P10 and P11 pull-up transistor control bit	0	Pull-up transistor OFF	
		1	Pull-up transistor ON	
PU01	Pins P02 and P03 pull-up transistor control bit	0	Pull-up transistor OFF	
		1	Pull-up transistor ON	
PU00	Pins P00 and P01 pull-up transistor control bit	0	Pull-up transistor OFF	
		1	Pull-up transistor ON	

Note: “R” represents read enabled, and “W” represents write enabled.

(3) Interrupt control register I1

The interrupt valid waveform for INTO pin/return level selection bit is assigned to bit 2, INTO pin edge detection circuit control bit is assigned to bit 1, and INTO pin timer 1 control enable bit is assigned to bit 0.

Set the contents of this register through register A with the **TI1A** instruction.

In addition, the **TAI1** instruction can be used to transfer the contents of register I1 to register A.

Table 2.9.6 shows the interrupt control register I1.

Table 2.9.6 Interrupt control register I1

Interrupt control register I1		at reset : 00002	at RAM back-up : state retained	R/W
I13	Not used	0	This bit has no function, but read/write is enabled.	
		1		
I12	Interrupt valid waveform for INTO pin/return level selection bit (Note 2)	0	Falling waveform (“L” level of INTO pin is recognized with the SNZIO instruction)/“L” level	
		1	Rising waveform (“H” level of INTO pin is recognized with the SNZIO instruction)/“H” level	
I11	INTO pin edge detection circuit control bit	0	One-sided edge detected	
		1	Both edges detected	
I10	INTO pin timer 1 control enable bit	0	Disabled	
		1	Enabled	

Notes 1: “R” represents read enabled, and “W” represents write enabled.

2: When the contents of I12 is changed, the external interrupt request flag EXF0 may be set. Accordingly, clear EXF0 flag with the **SNZO** instruction.

APPLICATION

2.9 RAM back-up

(4) Interrupt control register I2

The interrupt valid waveform for INT1 pin/return level selection bit is assigned to bit 2, the INT1 pin edge detection circuit control bit is assigned to bit 1, and the INT1 pin timer 1 control enable bit is assigned to bit 1.

Set the contents of this register through register A with the **T12A** instruction.

In addition, the **TAI2** instruction can be used to transfer the contents of register I2 to register A. Table 2.9.7 shows the interrupt control register I2.

Table 2.9.7 Interrupt control register I2

Interrupt control register I2		at reset : 00002	at RAM back-up : state retained	R/W
I23	Not used	0 1	This bit has no function, but read/write is enabled.	
I22	Interrupt valid waveform for INT1 pin/return level selection bit (Note 2)	0 1		
I21	INT1 pin edge detection circuit control bit	0 1	One-sided edge detected Both edges detected	
I20	INT1 pin timer 3 control enable bit	0 1	Disabled Enabled	

Notes 1: "R" represents read enabled, and "W" represents write enabled.

2: When the contents of I22 is changed, the external interrupt request flag EXF1 may be set. Accordingly, clear EXF1 flag with the **SNZI1** instruction.

2.9.3 Notes on use

(1) Key-on wakeup function

After setting ports (P1 specified with register PU0 and P0) which key-on wakeup function is valid to "H," execute the **POF** instruction.

"L" level is input to the falling edge detection circuit even if one of ports which key-on wakeup function is valid is in the "L" level state, and the edge is not detected.

(2) POF instruction

Execute the **POF** instruction immediately after executing the **EPOF** instruction to enter the RAM back-up state.

Note that system cannot enter the RAM back-up state when executing only the **POF** instruction.

Be sure to disable interrupts by executing the **DI** instruction before executing the **EPOF** instruction.

(3) Return from RAM back-up

After system returns from RAM back-up, set the undefined registers and flags.

Especially, be sure to set data pointer (registers Z, X, Y).

2.10 Oscillation circuit

The 4513/4514 Group has an internal oscillation circuit to produce the clock required for microcomputer operation.

The clock signal $f(XIN)$ is obtained by connecting a ceramic resonator to XIN pin and $XOUT$ pin.

2.10.1 Oscillation circuit

(1) $f(XIN)$ clock generating circuit

The clock signal $f(XIN)$ is obtained by connecting a ceramic resonator externally.

Connect this external circuit to pins XIN and $XOUT$ at the shortest distance. A feed-back resistor is built-in between XIN pin and $XOUT$ pin.

Figure 2.10.1 shows an example of an oscillation circuit connecting a ceramic resonator externally. Keep the maximum value of oscillation frequency within the range listed Table 2.10.1.

Table 2.10.1 Maximum value of oscillation frequency and supply voltage

Supply voltage	(System clock)	Oscillation frequency
2.5 V to 5.5 V	$(f(XIN)/2)$ Middle-speed mode	4.2 MHz
4.0 V to 5.5 V	$(f(XIN))$ High-speed mode	4.2 MHz
2.5 V to 5.5 V	$(f(XIN))$ High-speed mode	2.0 MHz
2.0 V to 5.5 V (Note)	$(f(XIN)/2)$ Middle-speed mode	3.0 MHz
2.0 V to 5.5 V (Note)	$(f(XIN))$ High-speed mode	1.5 MHz

Note: 2.5 V to 5.5 V for the One Timer PROM version.

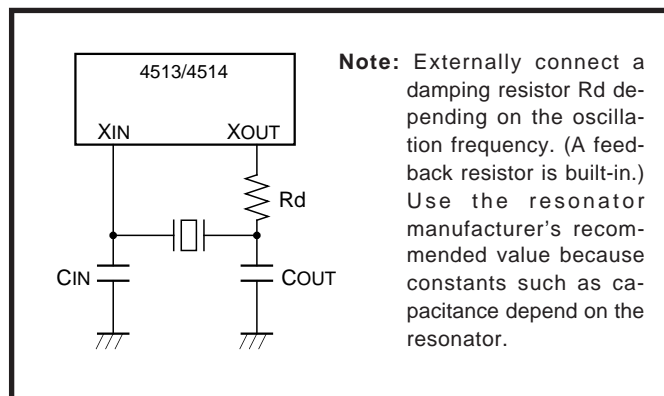

Fig. 2.10.1 Oscillation circuit example connecting ceramic resonator externally

APPLICATION

2.10 Oscillation circuit

2.10.2 Oscillation operation

System clock is supplied to CPU and peripheral device as the standard clock for the microcomputer operation. For the 4513/4514 Group, the clock ($f(X_{IN})$), ($f(X_{IN})/2$) which is supplied from the oscillation circuit is selected with the register MR.

Figure 2.10.2 shows the structure of the clock control circuit.

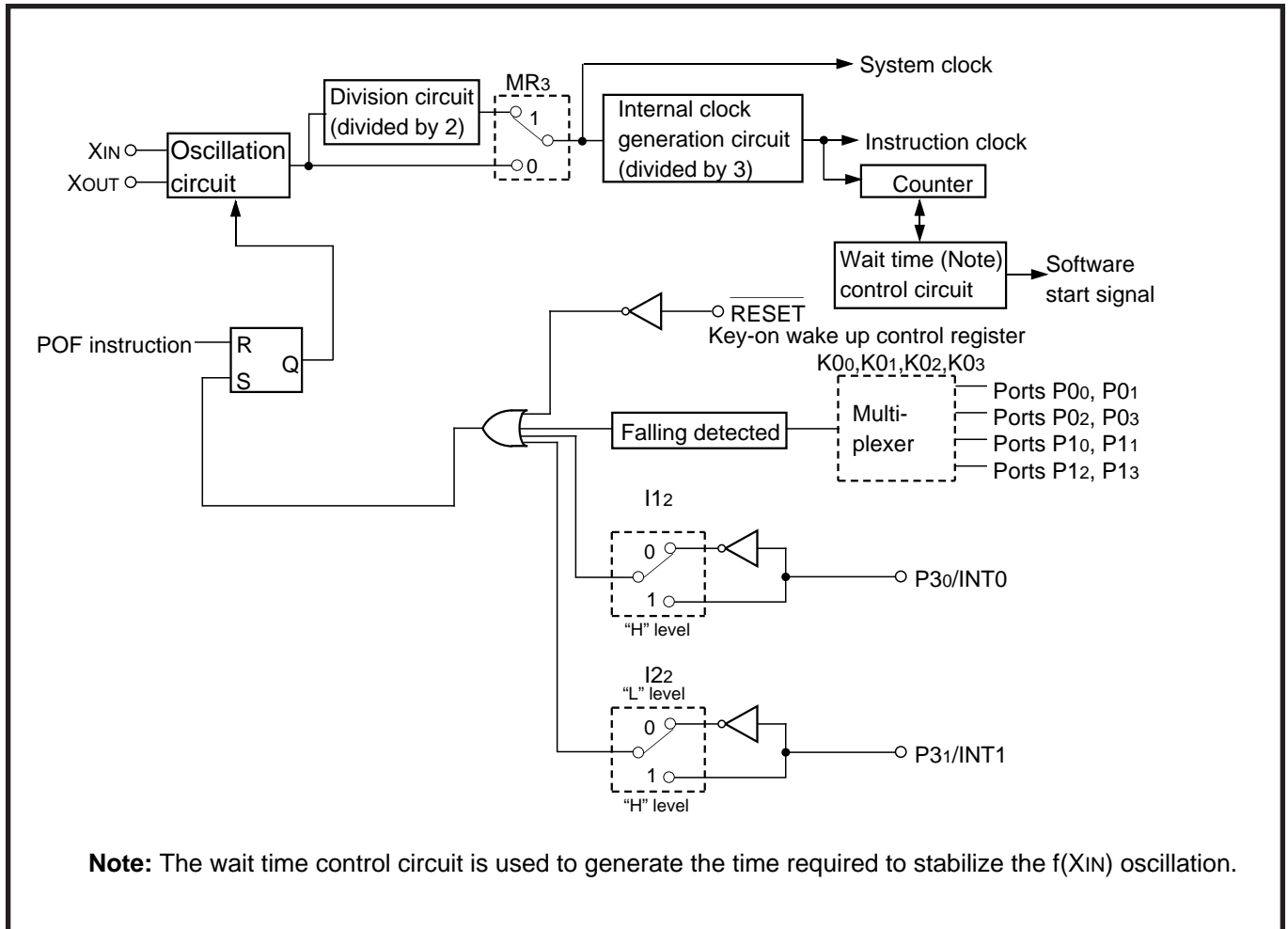

Fig. 2.10.2 Structure of clock control circuit

2.10.3 Notes on use

(1) Value of a part connected to an oscillator

Values of a capacitor and a resistor of the oscillation circuit depend on the connected oscillator and the board. Accordingly, consult the oscillator manufacturer for values of each part connected the oscillator.



CHAPTER 3

APPENDIX

- 3.1 Electrical characteristics
- 3.2 Typical characteristics
- 3.3 List of precautions
- 3.4 Notes on noise
- 3.5 Mask ROM confirmation form
- 3.6 Mark specification form
- 3.7 Package outline

APPENDIX

3.1 Electrical characteristics

3.1 Electrical characteristics

3.1.1 Absolute maximum ratings

Table 3.1.1 Absolute maximum ratings

Symbol	Parameter	Conditions		Ratings	Unit
V _{DD}	Supply voltage			-0.3 to 7.0	V
V _I	Input voltage P0, P1, P2, P3, P4, P5, $\overline{\text{RESET}}$, X _{IN} , VDCE			-0.3 to V _{DD} +0.3	V
V _I	Input voltage D0–D7			-0.3 to 13	V
V _I	Input voltage AIN0–AIN7			-0.3 to V _{DD} +0.3	V
V _O	Output voltage P0, P1, P3, P4, P5, $\overline{\text{RESET}}$	Output transistors in cut-off state		-0.3 to V _{DD} +0.3	V
V _O	Output voltage D0–D7			-0.3 to 13	V
V _O	Output voltage XOUT			-0.3 to V _{DD} +0.3	V
P _d	Power dissipation	T _a = 25 °C	Package: 42P2R	300	mW
			Package: 32P6B	300	
			Package: 32P4B	1100	
Topr	Operating temperature range			-20 to 85	°C
Tstg	Storage temperature range			-40 to 125	°C

3.1.2 Recommended operating conditions

Table 3.1.2 Recommended operating conditions 1

(Mask ROM version: Ta = -20 °C to 85 °C, VDD = 2.0 V to 5.5 V, unless otherwise noted)

(One Time PROM version: Ta = -20 °C to 85 °C, VDD = 2.5 V to 5.5 V, unless otherwise noted)

Symbol	Parameter	Conditions	Limits			Unit	
			Min.	Typ.	Max.		
VDD	Supply voltage	Mask ROM version	f(XIN) ≤ 4.2 MHz	2.5		5.5	V
		Middle-speed mode	f(XIN) ≤ 3.0 MHz	2.0		5.5	
		Mask ROM version	f(XIN) ≤ 4.2 MHz	4.0		5.5	
		High-speed mode	f(XIN) ≤ 2.0 MHz	2.5		5.5	
		High-speed mode	f(XIN) ≤ 1.5 MHz	2.0		5.5	
		One Time PROM version	f(XIN) ≤ 4.2 MHz	2.5		5.5	
		One Time PROM version	f(XIN) ≤ 4.2 MHz	4.0		5.5	
V _{RAM}	RAM back-up voltage (at RAM back-up mode)	Mask ROM version		1.8		V	
		One Time PROM version		2.0			
V _{SS}	Supply voltage			0		V	
V _{IH}	"H" level input voltage	P0, P1, P2, P3, P4, P5, XIN, VDCE		0.8V _{DD}		V _{DD}	V
V _{IH}	"H" level input voltage	D0-D7		0.8V _{DD}		12	V
V _{IH}	"H" level input voltage	RESET		0.85V _{DD}		V _{DD}	V
V _{IH}	"H" level input voltage	CNTR0, CNTR1, SIN, SCK, INT0, INT1		0.85V _{DD}		V _{DD}	V
V _{IL}	"L" level input voltage	P0, P1, P2, P3, P4, P5, D0-D7, XIN, VDCE		0		0.2V _{DD}	V
V _{IL}	"L" level input voltage	RESET		0		0.3V _{DD}	V
V _{IL}	"L" level input voltage	CNTR0, CNTR1, SIN, SCK, INT0, INT1		0		0.15V _{DD}	V
I _{OH} (peak)	"H" level peak output current	P5	V _{DD} = 5.0 V	-20			mA
			V _{DD} = 3.0 V	-10			
I _{OH} (avg)	"H" level average output current	P5 (Note)	V _{DD} = 5.0 V	-10			mA
			V _{DD} = 3.0 V	-5			
I _{OL} (peak)	"L" level peak output current	P3, RESET	V _{DD} = 5.0 V			10	mA
			V _{DD} = 3.0 V			4	
I _{OL} (peak)	"L" level peak output current	D6, D7	V _{DD} = 5.0 V			40	mA
			V _{DD} = 3.0 V			30	
I _{OL} (peak)	"L" level peak output current	D0-D5	V _{DD} = 5.0 V			24	mA
			V _{DD} = 3.0 V			12	
I _{OL} (peak)	"L" level peak output current	P0, P1, P4, P5, SCK, SOUT	V _{DD} = 5.0 V			24	mA
			V _{DD} = 3.0 V			12	
I _{OL} (avg)	"L" level average output current	P3, RESET (Note)	V _{DD} = 5.0 V			5	mA
			V _{DD} = 3.0 V			2	
I _{OL} (avg)	"L" level average output current	D6, D7 (Note)	V _{DD} = 5.0 V			30	mA
			V _{DD} = 3.0 V			15	
I _{OL} (avg)	"L" level average output current	D0-D5 (Note)	V _{DD} = 5.0 V			15	mA
			V _{DD} = 3.0 V			7	
I _{OL} (avg)	"L" level average output current	P0, P1, P4, P5, SCK, SOUT (Note)	V _{DD} = 5.0 V			12	mA
			V _{DD} = 3.0 V			6	
ΣI _{OH} (avg)	"H" level total average current	P5		-30			mA
ΣI _{OL} (avg)	"L" level total average current	P5, D, RESET, SCK, SOUT				80	
		P0, P1, P3, P4				80	

Note: The average output current (I_{OH}, I_{OL}) is the average value during 100 ms.

APPENDIX

3.1 Electrical characteristics

Table 3.1.3 Recommended operating conditions 2

(Mask ROM version: Ta = -20 °C to 85 °C, VDD = 2.0 V to 5.5 V, unless otherwise noted)

(One Time PROM version: Ta = -20 °C to 85 °C, VDD = 2.5 V to 5.5 V, unless otherwise noted)

Symbol	Parameter	Conditions		Limits			Unit
				Min.	Typ.	Max.	
f(XIN)	Oscillation frequency (with a ceramic resonator)	Mask ROM version Middle-speed mode	VDD = 2.5 V to 5.5 V			4.2	MHz
			VDD = 2.0 V to 5.5 V			3.0	
		One Time PROM version Middle-speed mode	VDD = 2.5 V to 5.5 V			4.2	
		Mask ROM version High-speed mode	VDD = 4.0 V to 5.5 V			4.2	
			VDD = 2.5 V to 5.5 V			2.0	
			VDD = 2.0 V to 5.5 V			1.5	
f(XIN)	Oscillation frequency (with external clock input)	Mask ROM version Middle-speed mode	VDD = 2.0 V to 5.5 V			3.0	MHz
		One Time PROM version Middle-speed mode	VDD = 2.5 V to 5.5 V			3.0	
		Mask ROM version High-speed mode	VDD = 4.0 V to 5.5 V			3.0	
			VDD = 2.5 V to 5.5 V			1.0	
			VDD = 2.0 V to 5.5 V			0.8	
		One Time PROM version High-speed mode	VDD = 4.0 V to 5.5 V			3.0	
	VDD = 2.5 V to 5.5 V			1.0			
tw(SCK)	Serial I/O external clock period ("H" and "L" pulse width)	Mask ROM version Middle-speed mode	VDD = 4.0 V to 5.5 V	1.5			μs
			VDD = 2.5 V to 5.5 V	3.0			
			VDD = 2.0 V to 5.5 V	4.0			
		One Time PROM version Middle-speed mode	VDD = 4.0 V to 5.5 V	1.5			μs
			VDD = 2.5 V to 5.5 V	3.0			
		Mask ROM version High-speed mode	VDD = 4.0 V to 5.5 V	750			ns
			VDD = 2.5 V to 5.5 V	1.5			μs
			VDD = 2.0 V to 5.5 V	2.0			
		One Time PROM version High-speed mode	VDD = 4.0 V to 5.5 V	750			ns
			VDD = 2.5 V to 5.5 V	1.5			μs
tw(CNTR)	Timer external input period ("H" and "L" pulse width)	Mask ROM version Middle-speed mode	VDD = 4.0 V to 5.5 V	1.5			μs
			VDD = 2.5 V to 5.5 V	3.0			
			VDD = 2.0 V to 5.5 V	4.0			
		One Time PROM version Middle-speed mode	VDD = 4.0 V to 5.5 V	1.5			μs
			VDD = 2.5 V to 5.5 V	3.0			
		Mask ROM version High-speed mode	VDD = 4.0 V to 5.5 V	750			ns
			VDD = 2.5 V to 5.5 V	1.5			μs
			VDD = 2.0 V to 5.5 V	2.0			
		One Time PROM version High-speed mode	VDD = 4.0 V to 5.5 V	750			ns
			VDD = 2.5 V to 5.5 V	1.5			μs

3.1.3 Electrical characteristics

Table 3.1.4 Electrical characteristics

(Mask ROM version: $T_a = -20\text{ }^\circ\text{C}$ to $85\text{ }^\circ\text{C}$, $V_{DD} = 2.0\text{ V}$ to 5.5 V , unless otherwise noted)

(One Time PROM version: $T_a = -20\text{ }^\circ\text{C}$ to $85\text{ }^\circ\text{C}$, $V_{DD} = 2.5\text{ V}$ to 5.5 V , unless otherwise noted)

Symbol	Parameter	Test conditions		Limits			Unit	
				Min.	Typ.	Max.		
VOH	"H" level output voltage P5	VDD = 5 V	IOH = -10 mA	3			V	
		VDD = 3 V	IOH = -5 mA	2				
VOL	"L" level output voltage P0, P1, P4, P5	VDD = 5 V	IOL = 12 mA			2	V	
		VDD = 3 V	IOL = 6 mA			0.9		
VOL	"L" level output voltage P3, $\overline{\text{RESET}}$	VDD = 5 V	IOL = 5 mA			2	V	
		VDD = 3 V	IOL = 2 mA			0.9		
VOL	"L" level output voltage D6, D7	VDD = 5 V	IOL = 30 mA			2	V	
			IOL = 10 mA			0.9		
		VDD = 3 V	IOL = 15 mA			2	V	
			IOL = 5 mA			0.9		
VOL	"L" level output voltage D0-D5	VDD = 5 V	IOL = 15 mA			2	V	
		VDD = 3 V	IOL = 3 mA			0.9		
I _{IH}	"H" level input current P0, P1, P2, P3, P4, P5, $\overline{\text{RESET}}$, VDCE	VI = VDD, port P4 selected, port P5: input state				1	μA	
I _{IH}	"H" level input current D0-D7	VI = 12 V				1	μA	
I _{IL}	"L" level input current P0, P1, P2, P3, P4, P5, $\overline{\text{RESET}}$, VDCE	VI = 0 V No pull-up of ports P0 and P1, port P4 selected, port P5: input state		-1			μA	
I _{IL}	"L" level input current D0-D7	VI = 0 V		-1			μA	
IDD	Supply current	at active mode	VDD = 5 V	f(XIN) = 4.0 MHz	1.8	5.5	mA	
			Middle-speed mode	f(XIN) = 400 kHz	0.5	1.5		
			VDD = 3 V	f(XIN) = 4.0 MHz	0.9	2.7		
			Middle-speed mode	f(XIN) = 400 kHz	0.2	0.6		
			VDD = 5 V	f(XIN) = 4.0 MHz	3.0	9.0		
			High-speed mode	f(XIN) = 400 kHz	0.6	1.8		
			VDD = 3 V	f(XIN) = 2.0 MHz	0.9	2.7		
			High-speed mode	f(XIN) = 400 kHz	0.3	0.9		
		at RAM back-up mode	Ta = 25 °C			0.1	1	μA
			VDD = 5 V				10	
		VDD = 3 V			6			
RPU	Pull-up resistor value	VDD = 5 V	VI = 0 V	20	50	125	k Ω	
		VDD = 3 V		40	100	250		
VT+ - VT-	Hysteresis INT0, INT1, CNTR0, CNTR1, SIN, SCK	VDD = 5 V			0.3		V	
		VDD = 3 V			0.3			
VT+ - VT-	Hysteresis $\overline{\text{RESET}}$	VDD = 5 V			1.5		V	
		VDD = 3 V			0.6			

APPENDIX

3.1 Electrical characteristics

3.1.4 A-D converter recommended operating conditions

Table 3.1.5 A-D converter recommended operating conditions

(Comparator mode included, Ta = -20 °C to 85 °C, unless otherwise noted)

Symbol	Parameter	Conditions	Limits			Unit
			Min.	Typ.	Max.	
VDD	Supply voltage		2.7		5.5	V
VI _A	Analog input voltage		0		VDD	V
f(XIN)	Oscillation frequency	Middle-speed mode, VDD ≥ 2.7 V	0.8			MHz
		High-speed mode, VDD ≥ 2.7 V	0.4			MHz

Table 3.1.6 A-D converter characteristics

(Ta = -20 °C to 85 °C, unless otherwise noted)

Symbol	Parameter	Test conditions	Limits			Unit
			Min.	Typ.	Max.	
–	Resolution				10	bits
–	Linearity error	Ta = 25 °C, VDD = 2.7 V to 5.5 V			±2	LSB
		Ta = -25 °C to 85 °C, VDD = 3.0 V to 5.5 V				
–	Differential non-linearity error	Ta = 25 °C, VDD = 2.7 V to 5.5 V			±0.9	LSB
		Ta = -25 °C to 85 °C, VDD = 3.0 V to 5.5 V				
V0T	Zero transition voltage	VDD = 5.12 V	0	5	20	mV
		VDD = 3.072 V	0	3	15	
VFST	Full-scale transition voltage	VDD = 5.12 V	5105	5115	5125	mV
		VDD = 3.072 V	3060	3069	3075	
IADD	A-D operating current	VDD = 5.0 V f(XIN) = 0.4 MHz to 4.0 MHz		0.7	2.0	mA
		VDD = 3.0 V f(XIN) = 0.4 MHz to 2.0 MHz		0.2	0.4	
TCONV	A-D conversion time	f(XIN) = 4.0 MHz, Middle-speed mode			93.0	μs
		f(XIN) = 4.0 MHz, High-speed mode			46.5	
–	Comparator resolution	Comparator mode			8	bits
–	Comparator error (Note)	VDD = 5.12 V			±20	mV
		VDD = 3.072 V			±15	
–	Comparator comparison time	f(XIN) = 4.0 MHz, Middle-speed mode			12	μs
		f(XIN) = 4.0 MHz, High-speed mode			6	

Note: As for the error from the ideal value in the comparator mode, when the contents of the comparator register is n, the logic value of the comparison voltage V_{ref} which is generated by the built-in DA converter can be obtained by the following formula.

Logic value of comparison voltage V_{ref}

$$V_{ref} = \frac{V_{DD}}{256} \times n$$

n = Value of register AD (n = 0 to 255)

3.1.5 Voltage drop detection circuit characteristics

Table 3.1.7 Voltage drop detection circuit characteristics

(Ta = -20 °C to 85 °C, unless otherwise noted)

Symbol	Parameter	Test conditions	Limits			Unit
			Min.	Typ.	Max.	
VRST	Detection voltage		2.7		4.1	V
		Ta = 25 °C	3.3	3.5	3.7	
IRST	Operation current of voltage drop detection circuit	VDD = 5.0 V		50	100	μA

3.1.6 Voltage comparator characteristics

Table 3.1.8 Voltage comparator recommended operating conditions

(Ta = -20 °C to 85 °C, unless otherwise noted)

Symbol	Parameter	Conditions	Limits			Unit
			Min.	Typ.	Max.	
VDD	Supply voltage		3.0		5.5	V
VINCMP	Voltage comparator input voltage	VDD = 3.0 V to 5.5 V	0.3VDD		0.7VDD	V
tCMP	Voltage comparator response time	VDD = 3.0 V to 5.5 V			20	μs

Table 3.1.9 Voltage comparator characteristics

(Ta = -20 °C to 85 °C, VDD = 3.0 V to 5.5 V, unless otherwise noted)

Symbol	Parameter	Test conditions	Limits			Unit
			Min.	Typ.	Max.	
–	Comparison decision voltage error	CMP0- > CMP0+, CMP0- < CMP0+ CMP1- > CMP1+, CMP1- < CMP1+		20	100	mV
ICMP	Voltage comparator operation current	VDD = 5.0 V		15	50	μA

3.1.7 Basic timing diagram

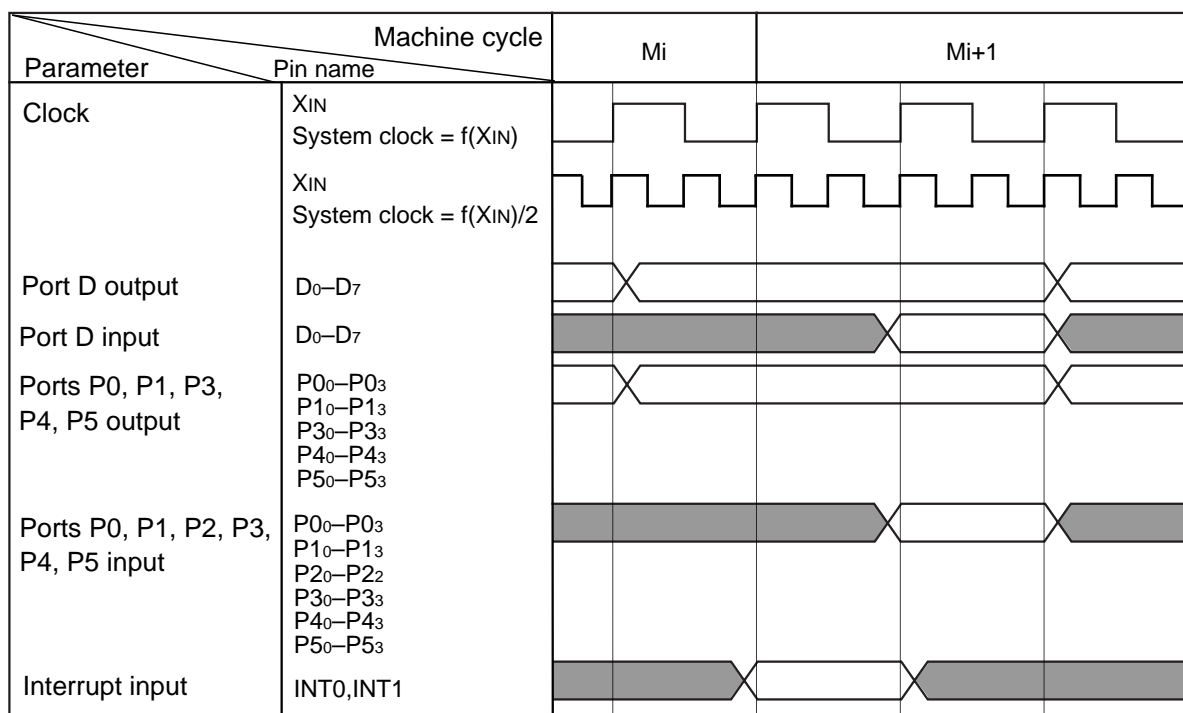

APPENDIX

3.2 Typical characteristics

3.2 Typical characteristics

3.2.1 VDD–IDD characteristics

(1) CPU operating, middle-speed mode

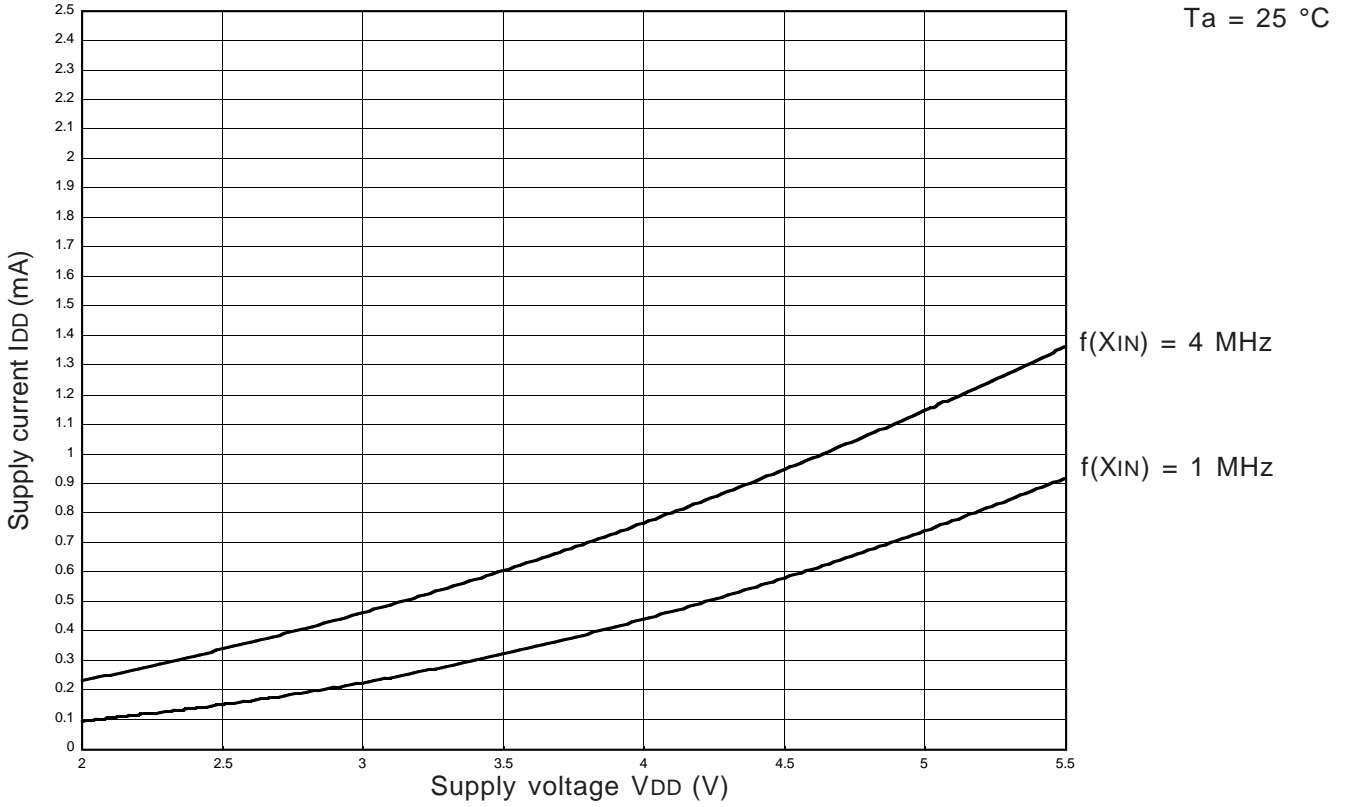

(2) CPU operating, high-speed mode

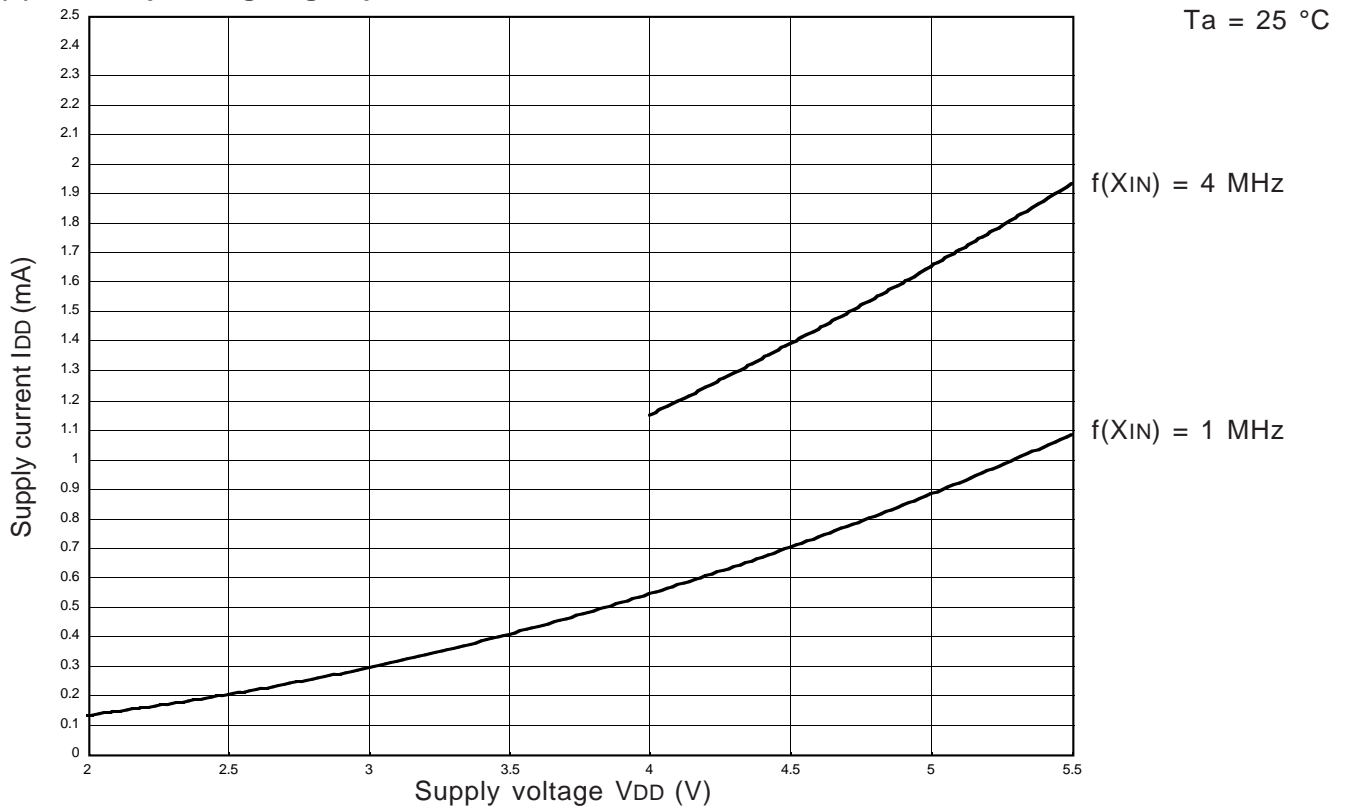

(3) A-D operating, middle-speed mode

Ta = 25 °C

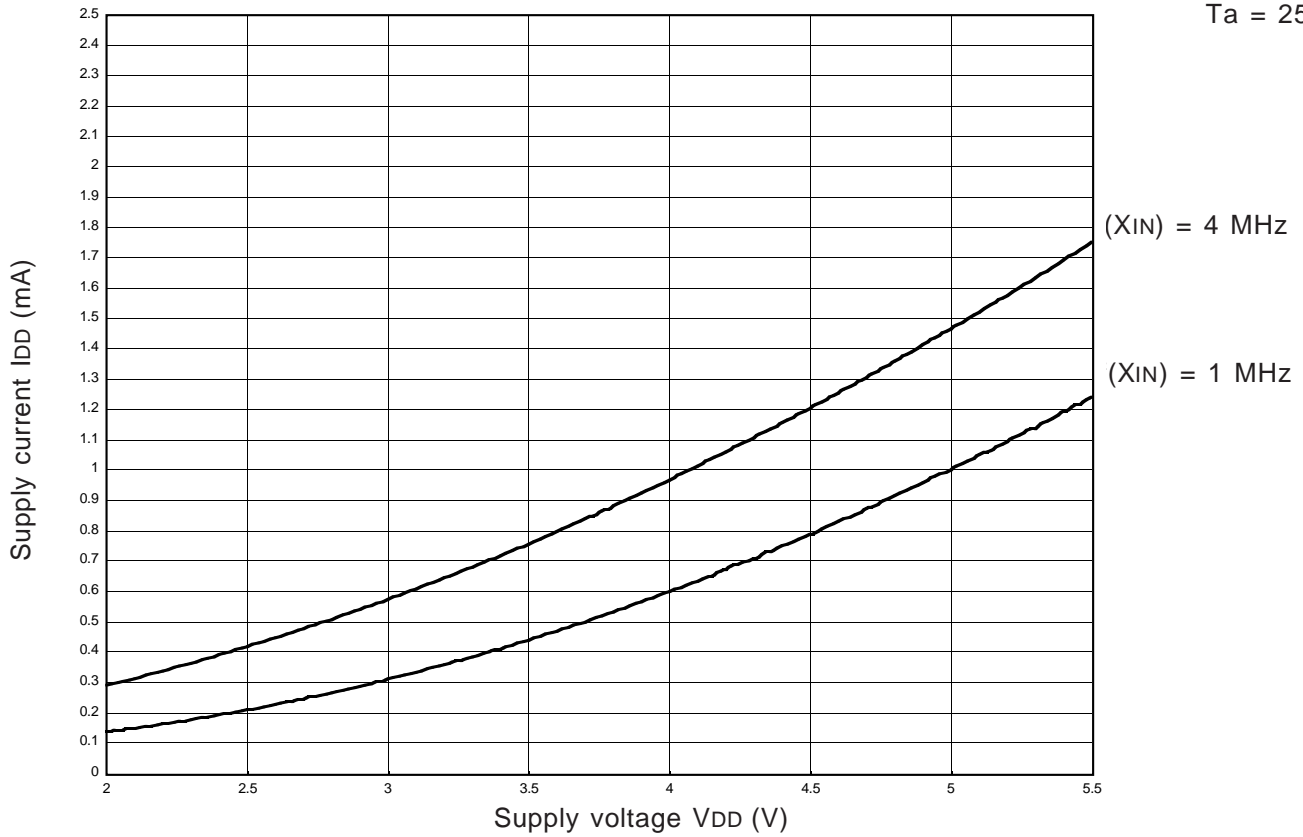

(4) A-D operating, high-speed mode

Ta = 25 °C

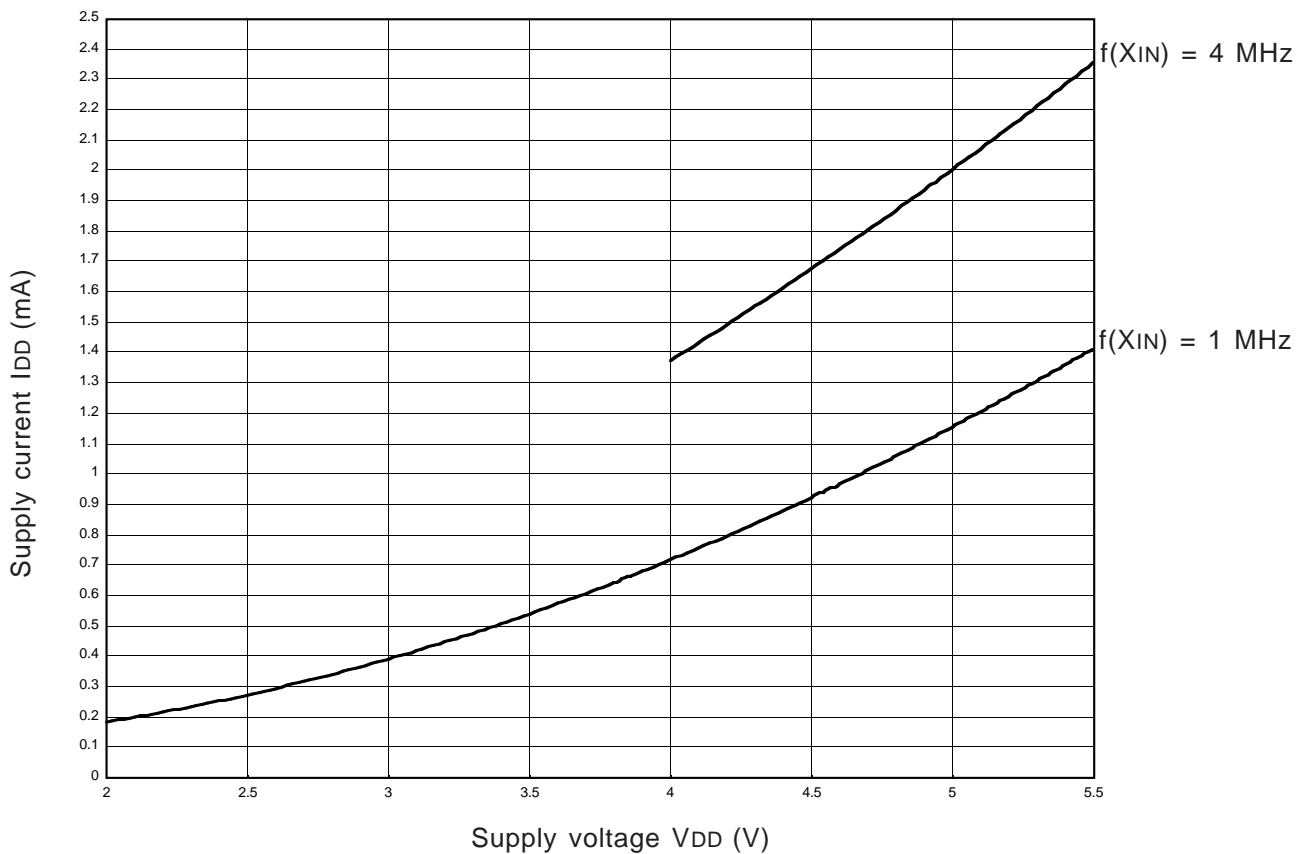

APPENDIX

3.2 Typical characteristics

(5) RAM back-up

Ta = 25 °C

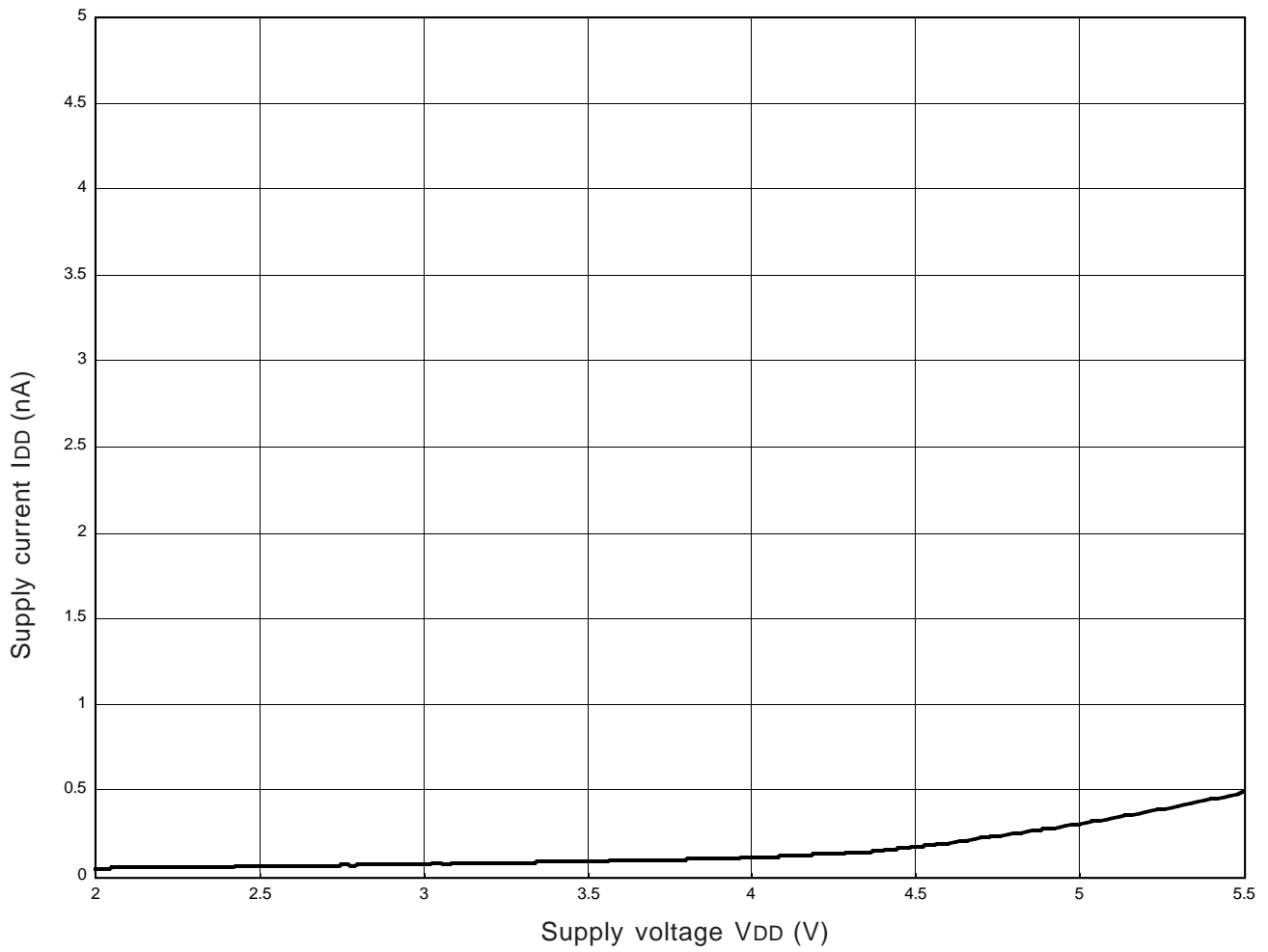

3.2.2 VOL–IOL characteristics

(1) Ports P0, P1, P4, P5, SCK, SOUT

Ta = 25 °C

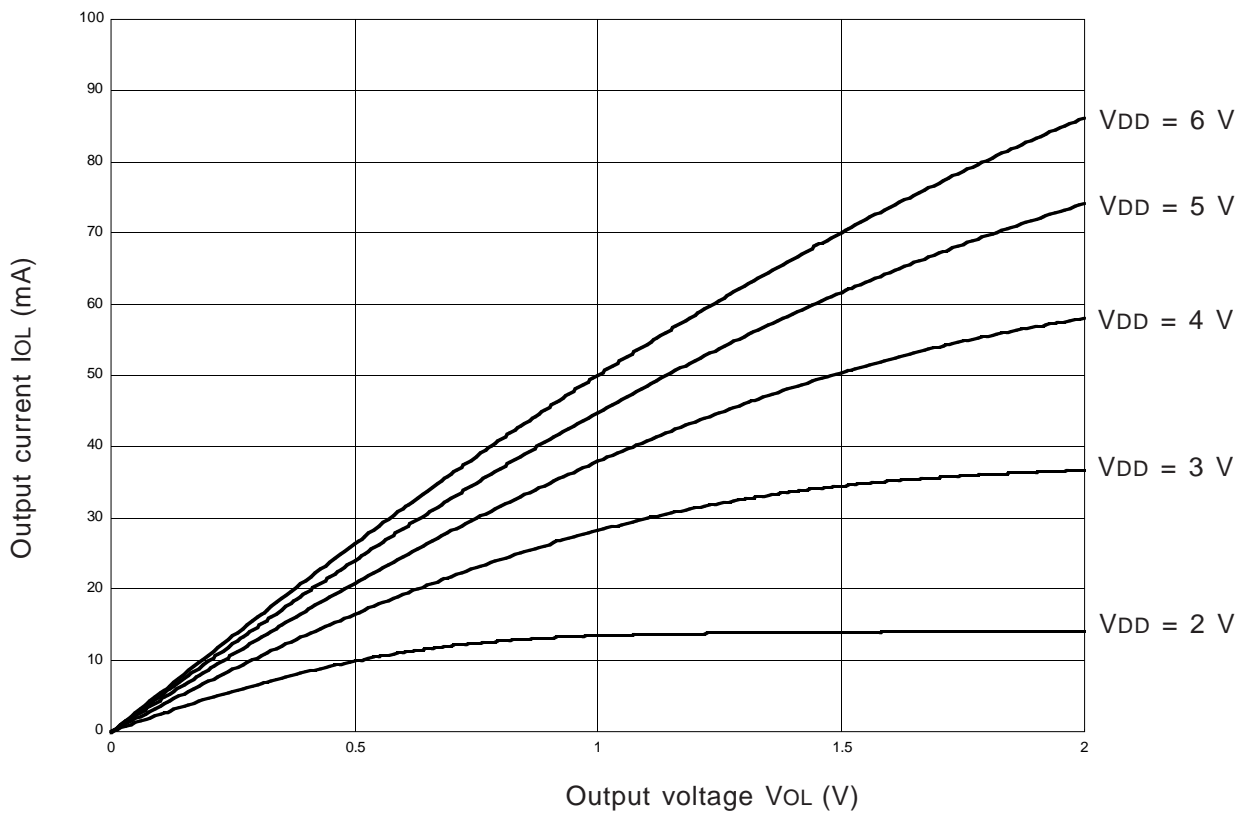

(2) Port P3, $\overline{\text{RESET}}$ pin

Ta = 25 °C

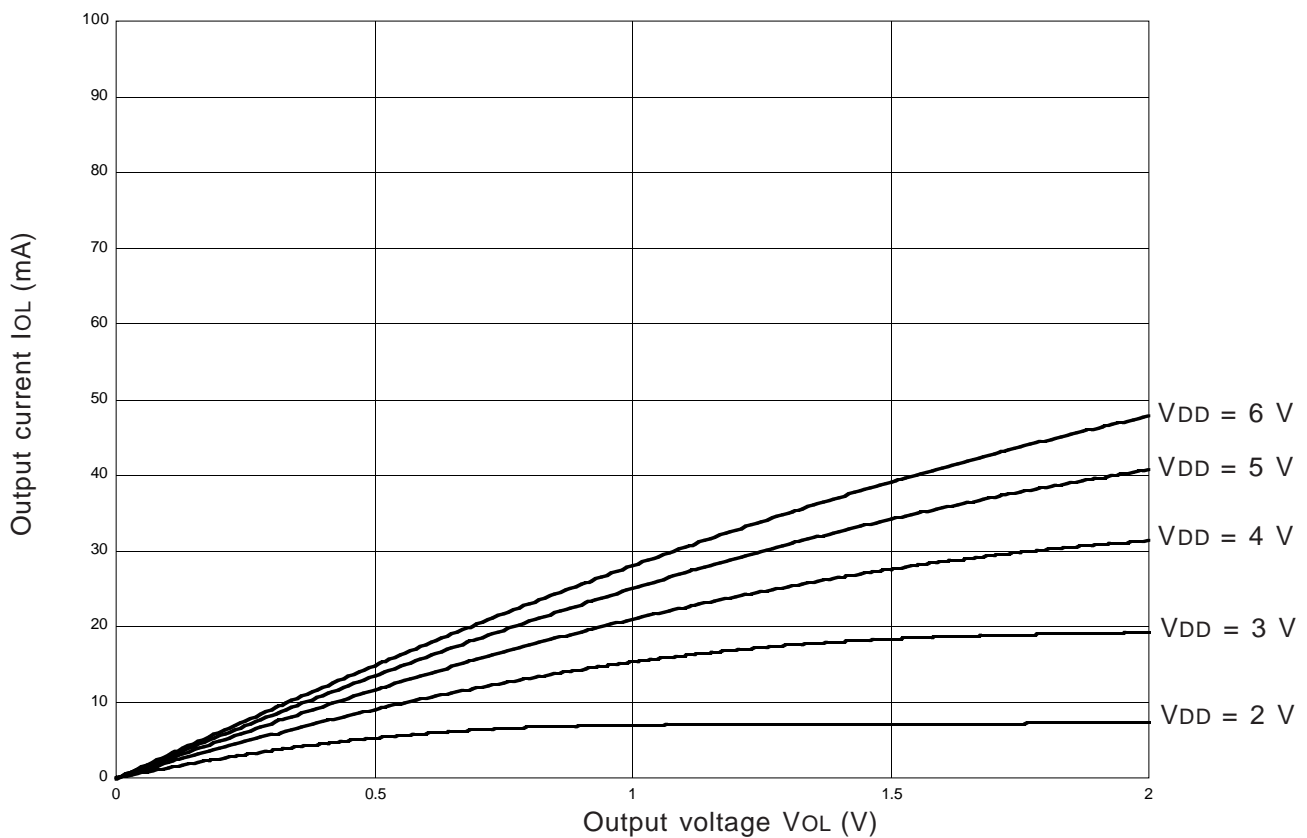

APPENDIX

3.2 Typical characteristics

(3) Pins D0–D5

Ta = 25 °C

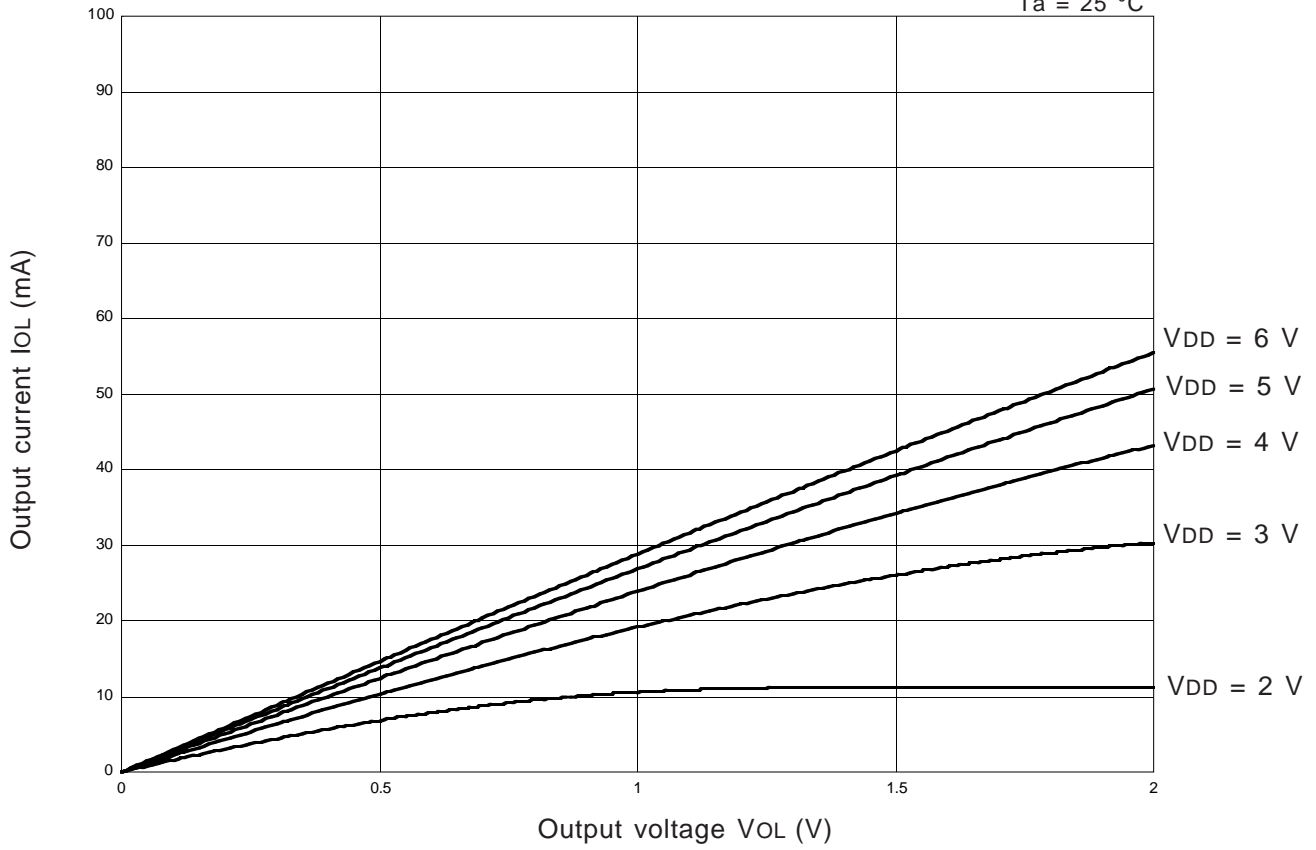

(4) Pins D6/CNTR0, D7/CNTR1

Ta = 25 °C

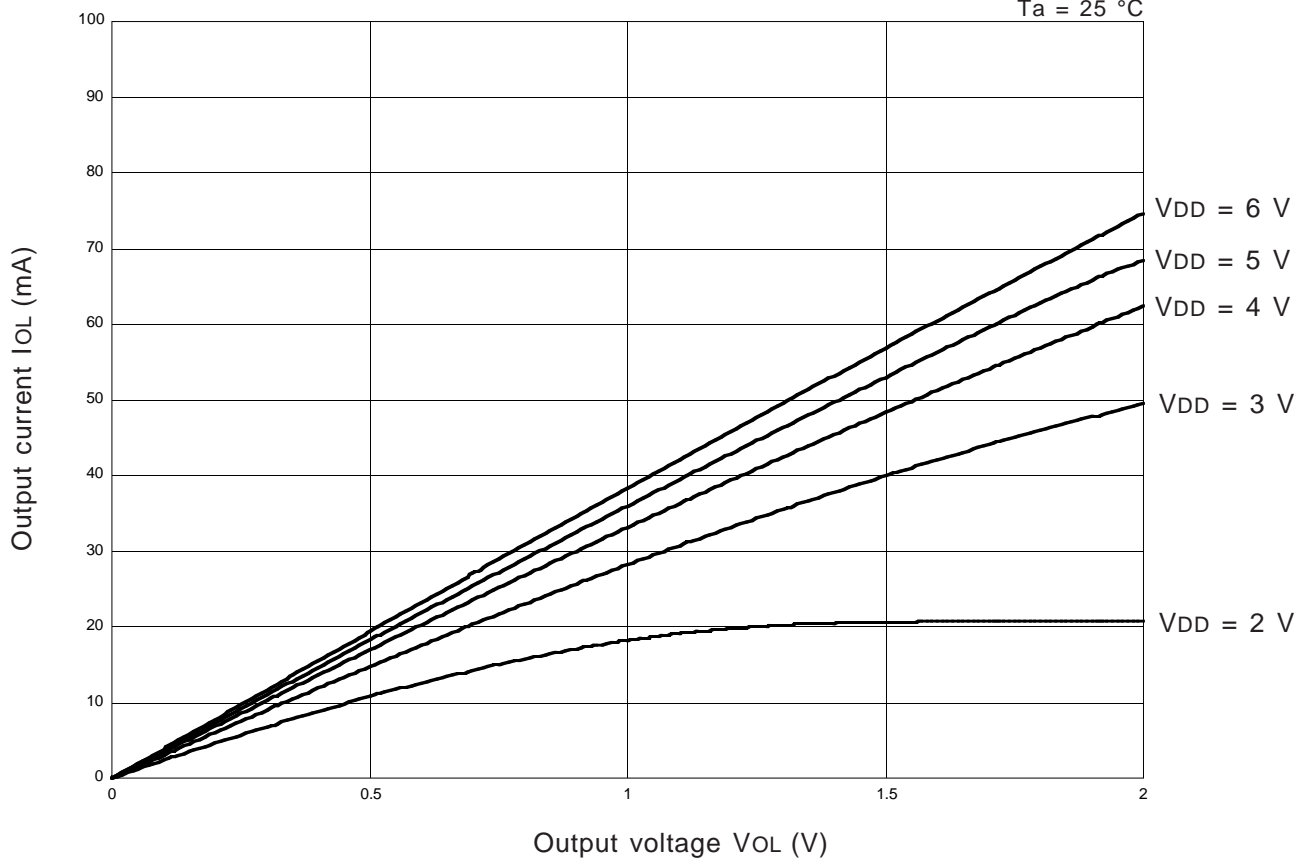

3.2.3 V_{OH} – I_{OH} characteristics (Port P5)

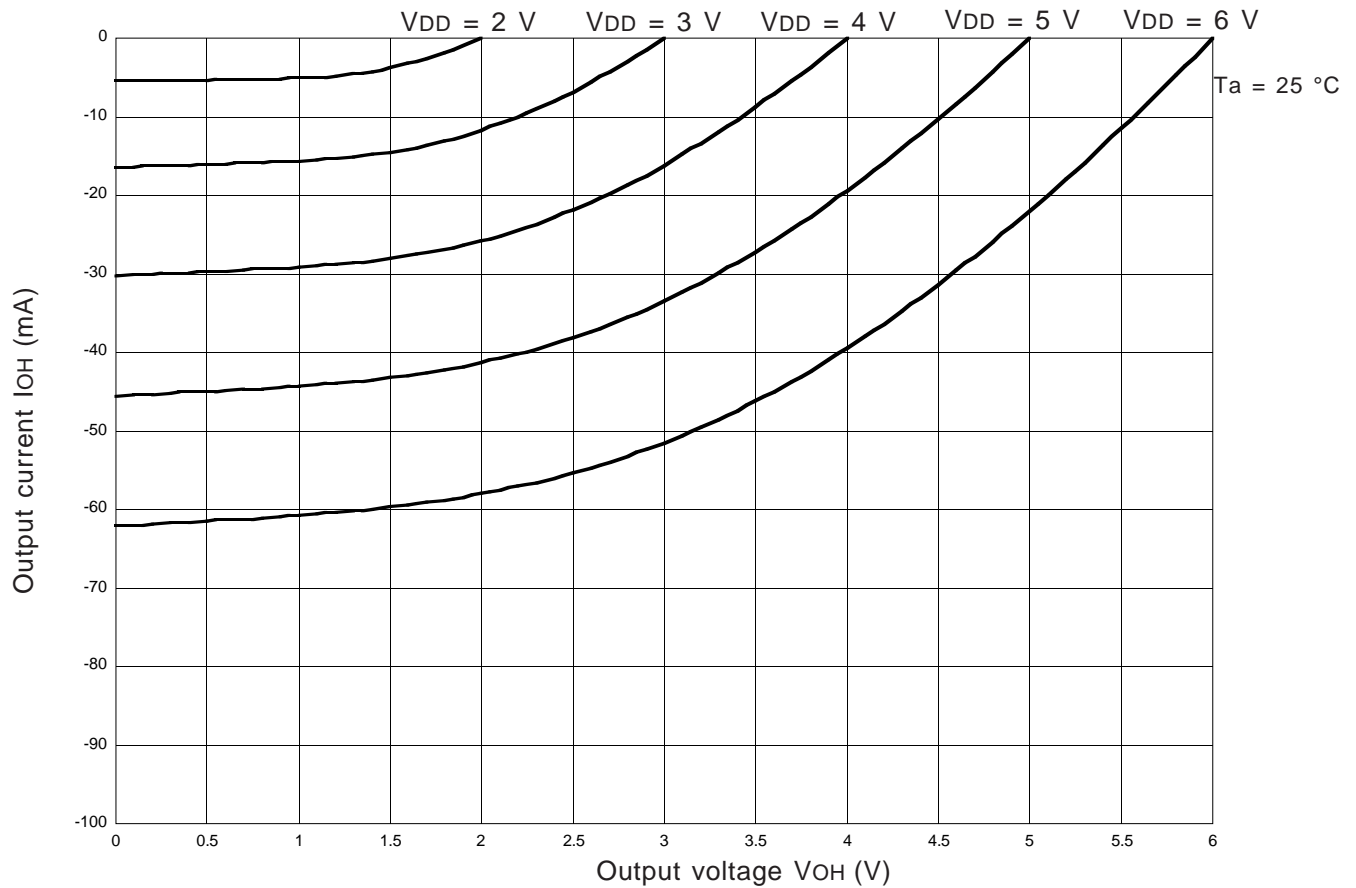

3.2.4 V_{DD} – R_{PU} characteristics (Ports P0, P1)

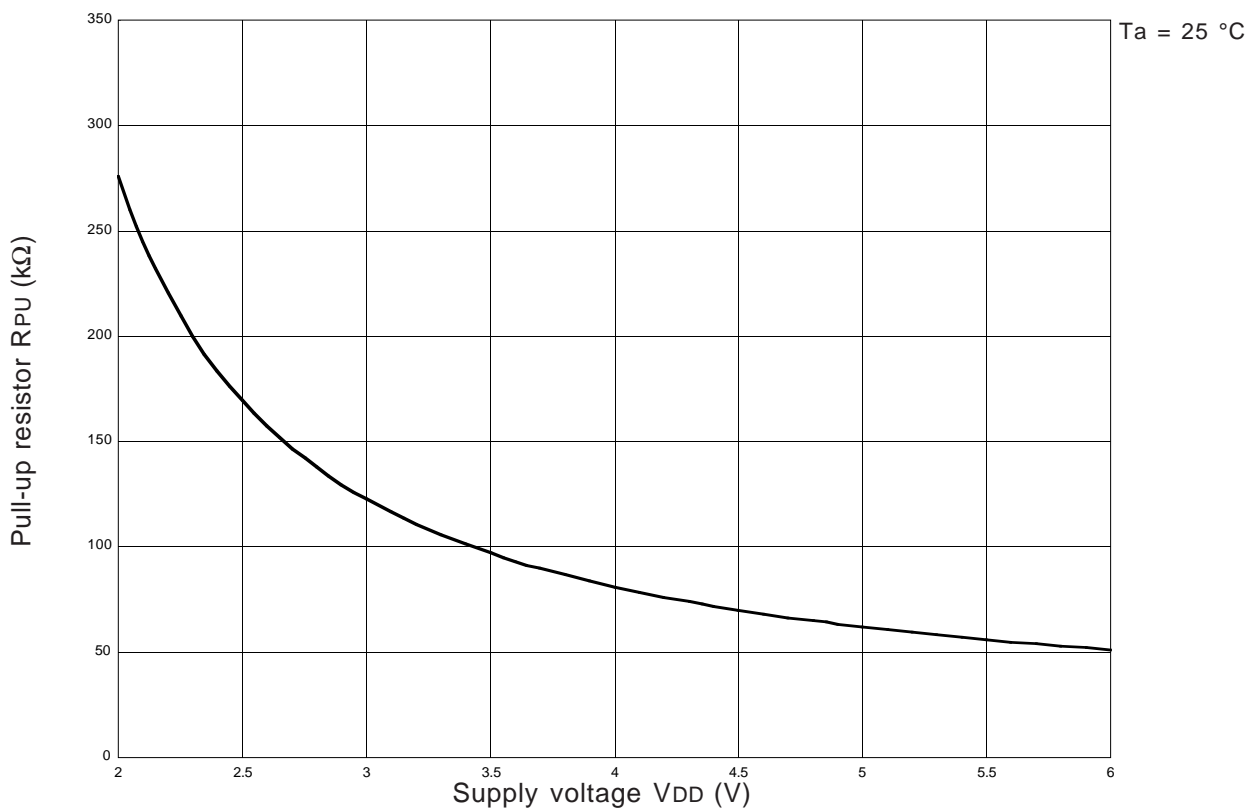

APPENDIX

3.2 Typical characteristics

3.2.5 A-D converter typical characteristics

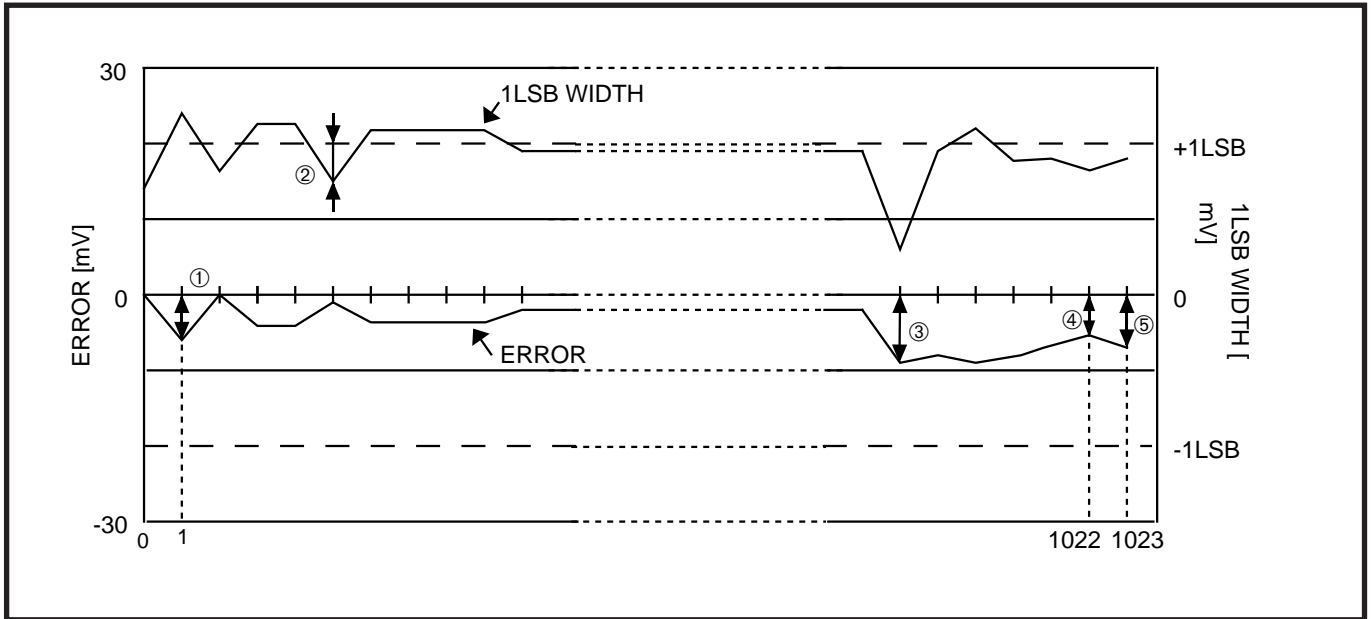

Fig. 3.2.1 A-D conversion characteristics data

Figure 3.2.1 shows the A-D accuracy measurement data.

- (1) Non-linearity error This means a deviation from the ideal characteristics between V_0 to V_{1022} of actual A-D conversion characteristics. In Figure 3.2.1, it is $(4-1)/1\text{LSB}$.
- (2) Differential non-linearity error This means a deviation from the ideal characteristics between the input voltages V_0 to V_{1022} necessary to change the output data to "1." In Figure 3.2.1, this is $2/1\text{LSB}$.
- (3) Zero transition error This means a deviation from the ideal characteristics between the input voltages 0 to V_{DD} when the output data changes from "0" to "1." In Figure 3.2.1, this is the value of ①.
- (4) Full-scale transition error This means a deviation from the ideal characteristics between the input voltages 0 to V_{DD} when the output data changes from "1022" to "1023." In Figure 3.2.1, this is the value of ⑤.
- (5) Absolute accuracy This means a deviation from the ideal characteristics between 0 to V_{DD} of actual A-D conversion characteristics. In Figure 3.2.1, this is the value of ERROR in each of ①, ③, ④ and ⑤.

For the A-D converter characteristics, refer to the section 3.1 Electrical characteristics.

(1) $V_{DD} = 3.072\text{ V}$, $f(X_{IN}) = 2\text{ MHz}$, high-speed mode

$T_a = 25\text{ }^\circ\text{C}$

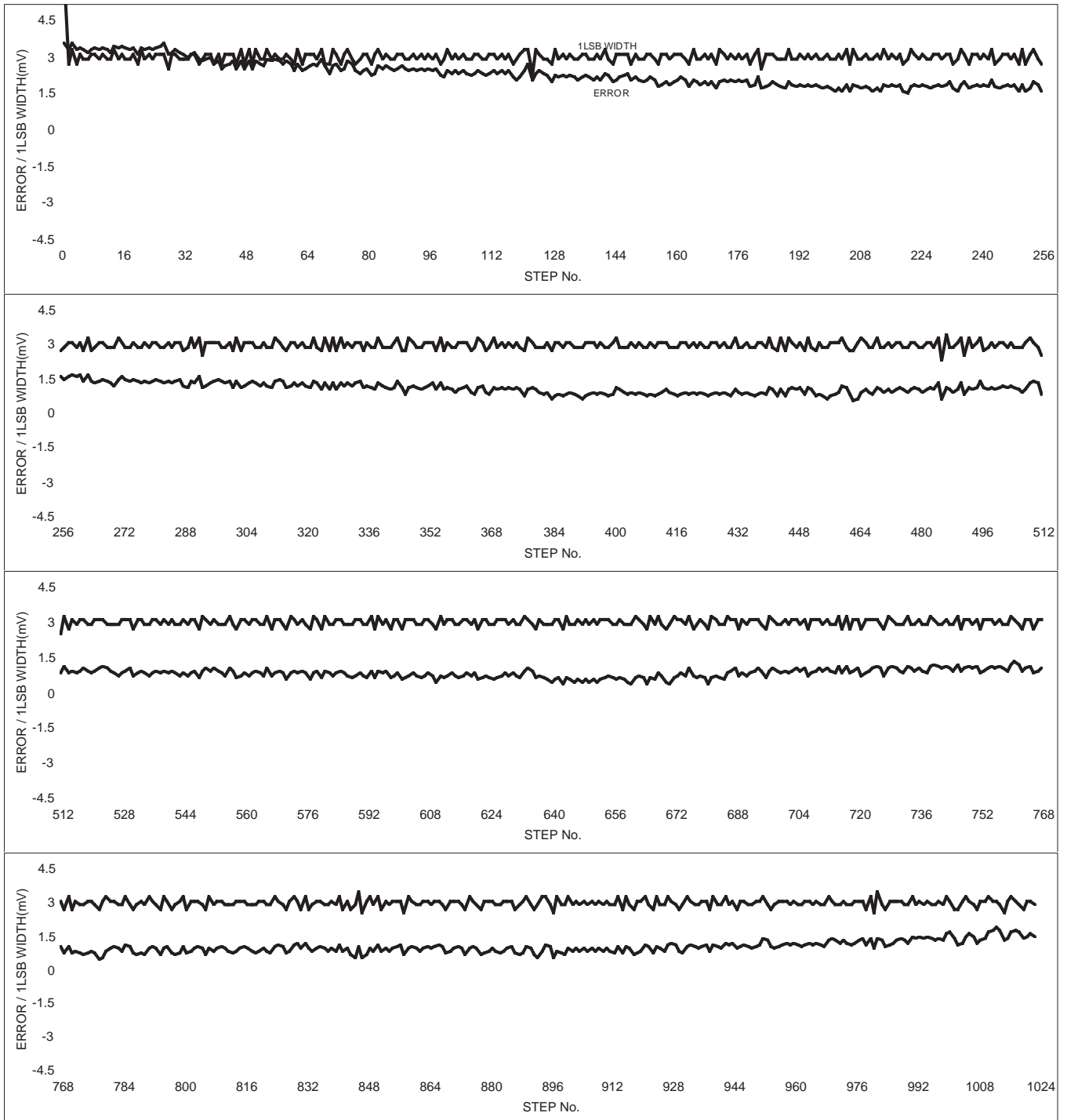

APPENDIX

3.2 Typical characteristics

(2) $V_{DD} = 5.12 \text{ V}$, $f(X_{IN}) = 4 \text{ MHz}$, high-speed mode

$T_a = 25 \text{ }^\circ\text{C}$

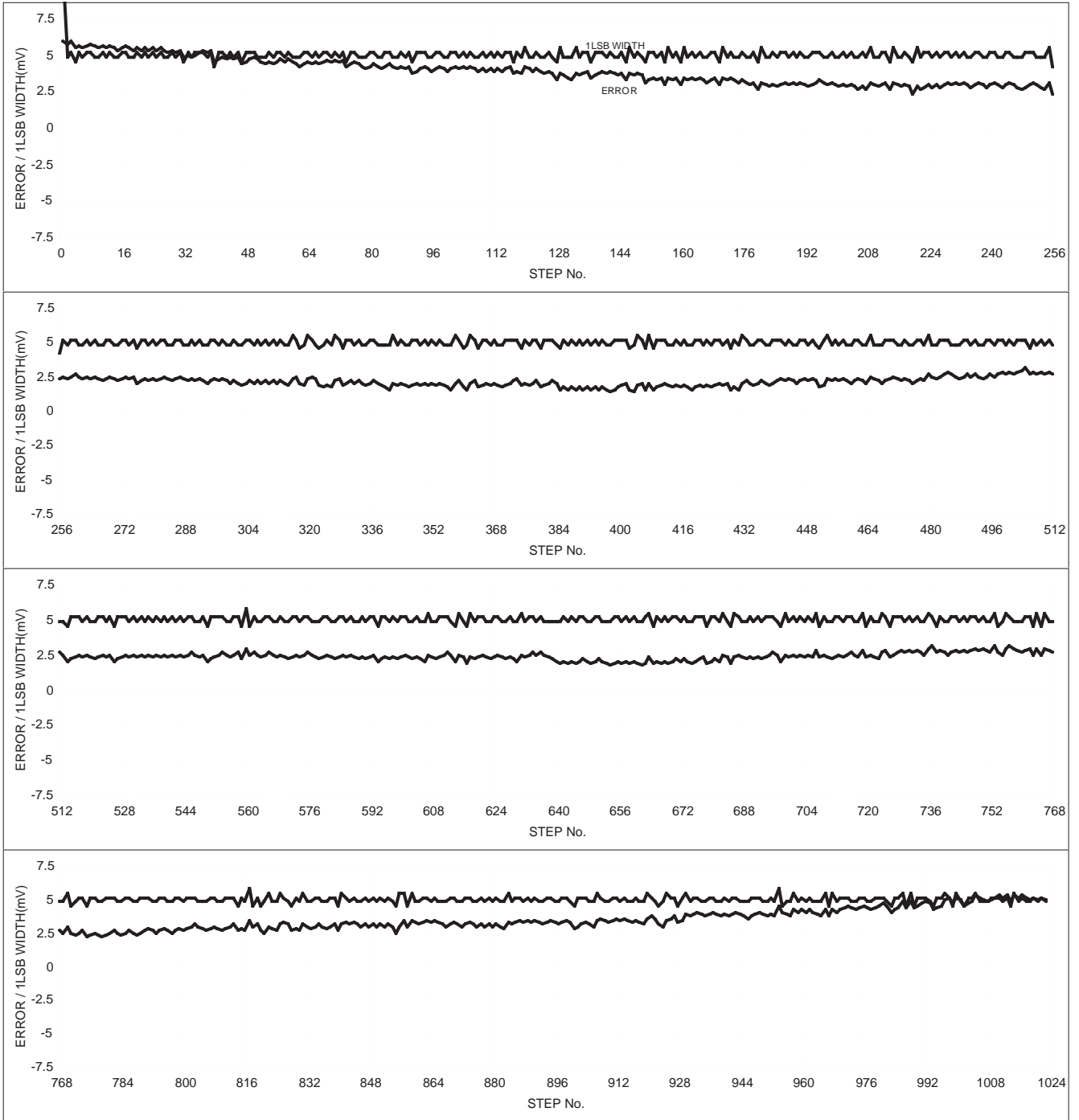

3.2.6 Analog input current characteristics pins AIN0–AIN7

(1) $V_{DD} = 3.0\text{ V}$, $f(X_{IN}) = 2\text{ MHz}$, middle-speed mode

$T_a = 25\text{ }^\circ\text{C}$

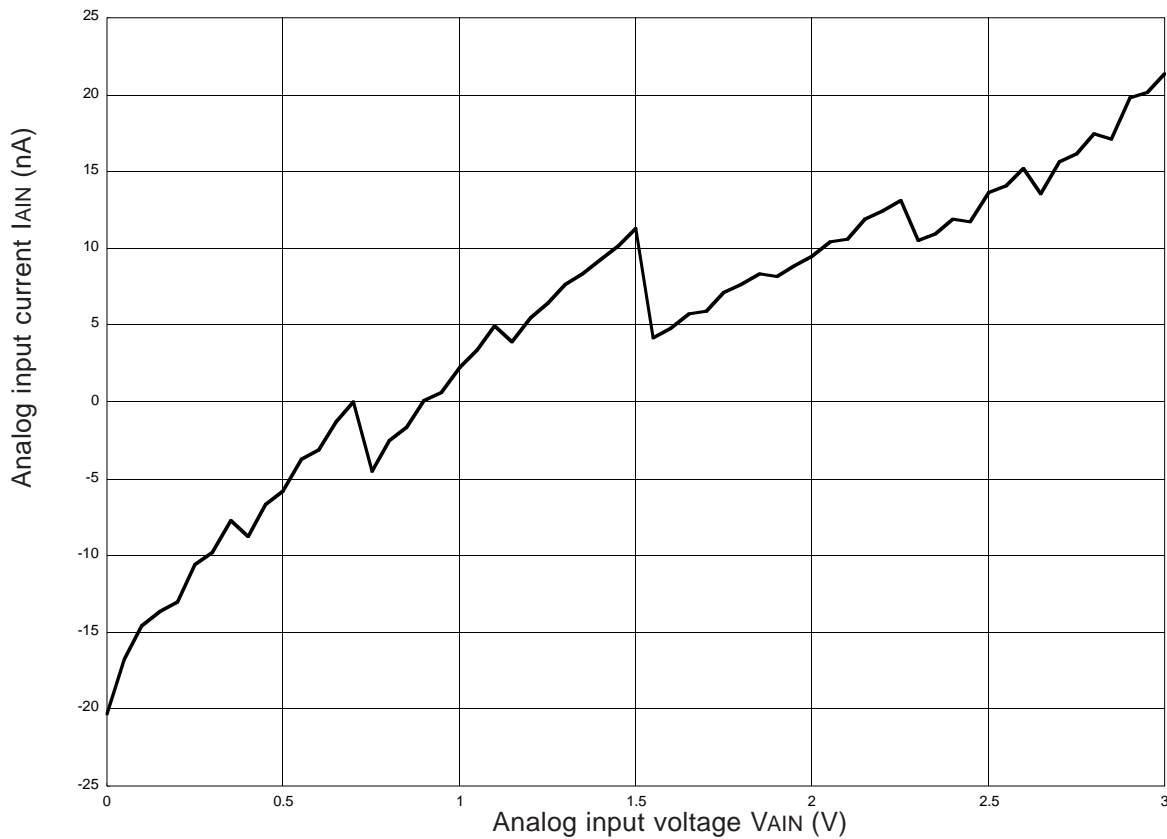

(2) $V_{DD} = 3.0\text{ V}$, $f(X_{IN}) = 4\text{ MHz}$, middle-speed mode

$T_a = 25\text{ }^\circ\text{C}$

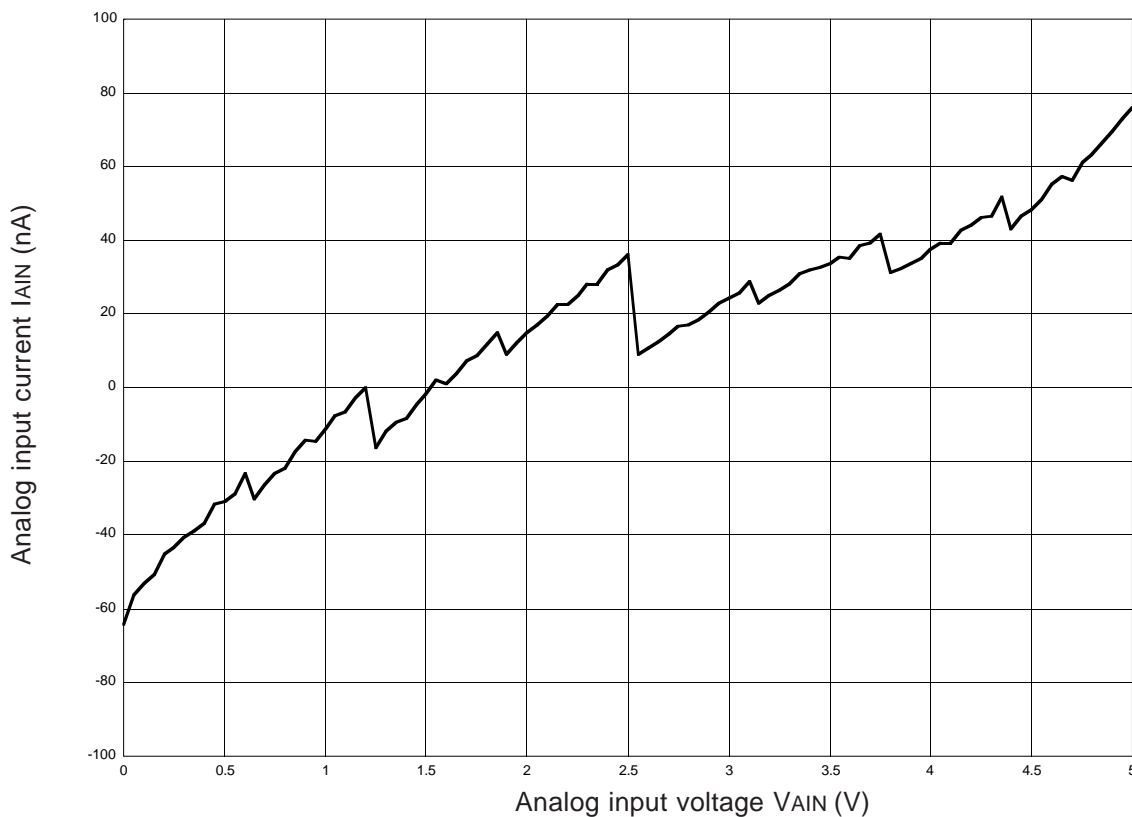

APPENDIX

3.2 Typical characteristics

(3) $V_{DD} = 3.0\text{ V}$, $f(X_{IN}) = 2\text{ MHz}$, high-speed mode

$T_a = 25\text{ }^\circ\text{C}$

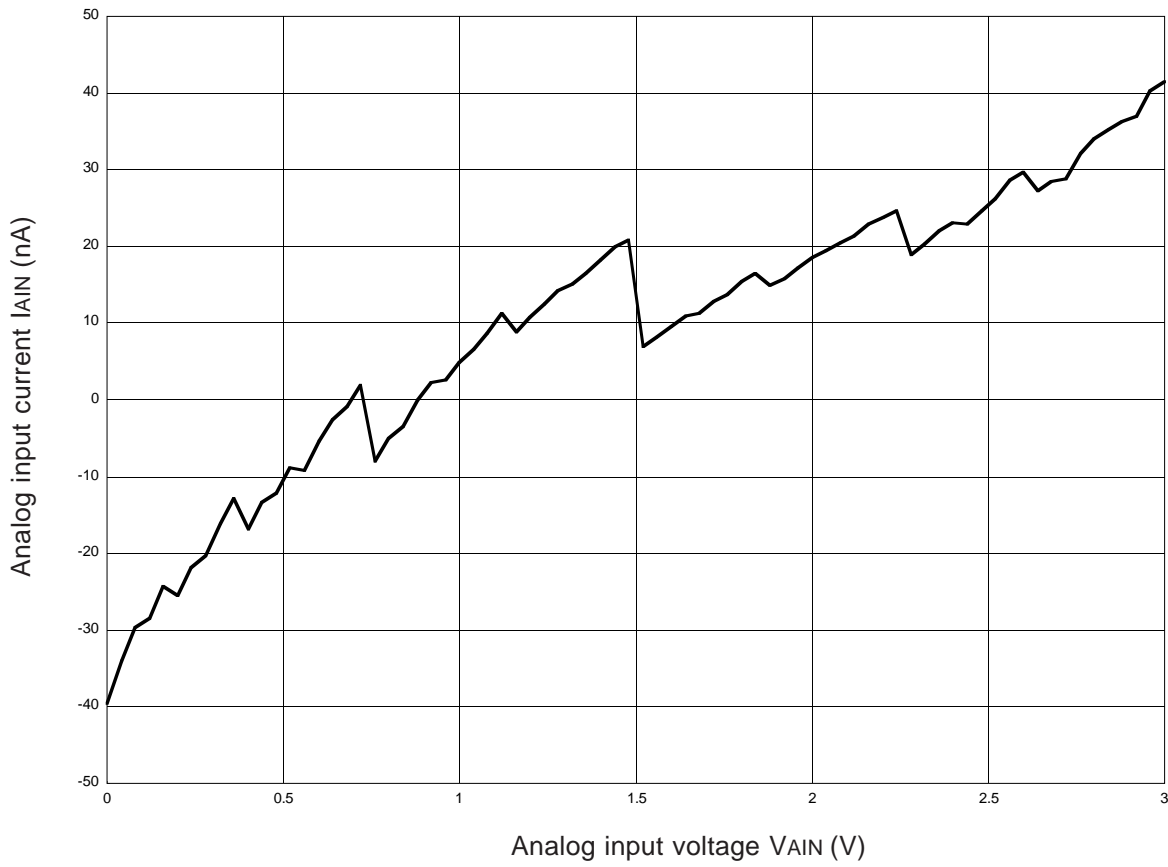

(4) $V_{DD} = 5.0\text{ V}$, $f(X_{IN}) = 4\text{ MHz}$, high-speed mode

$T_a = 25\text{ }^\circ\text{C}$

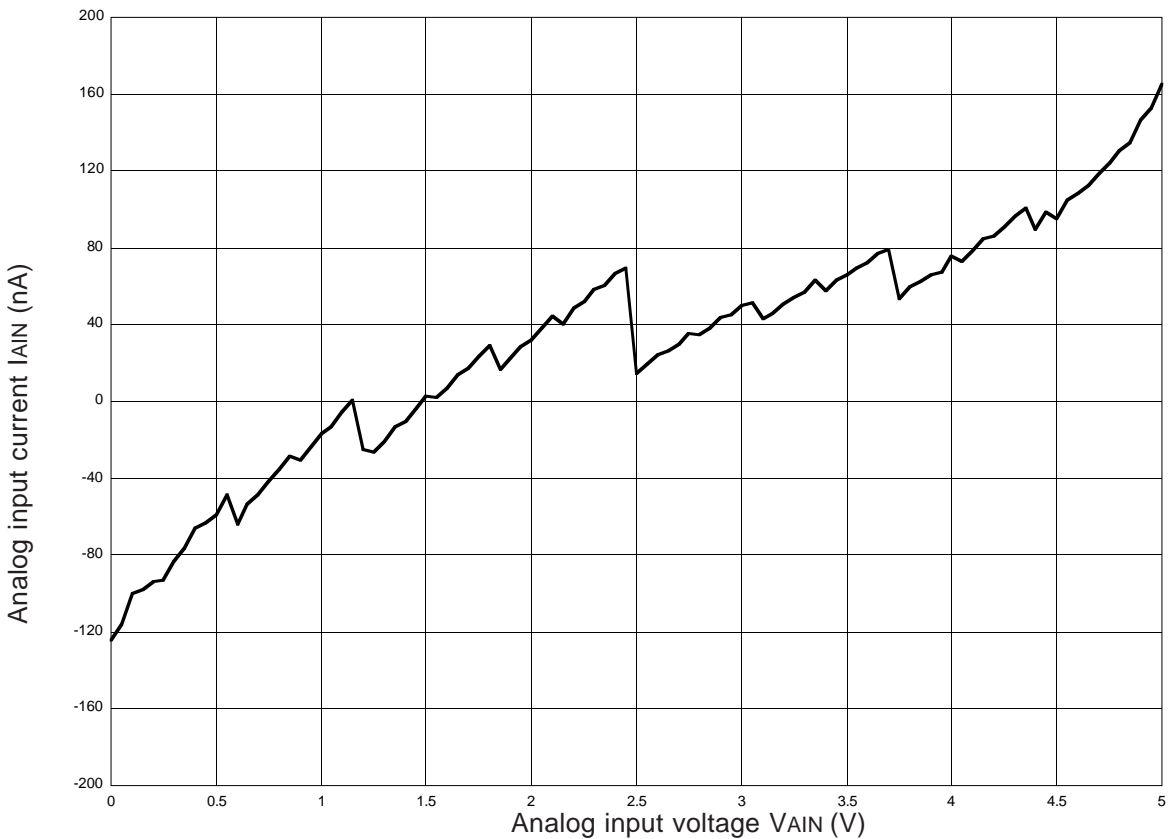

3.2.7 V_{DD}-V_{IH}/V_{IL} characteristics

(1) $\overline{\text{RESET}}$ pin

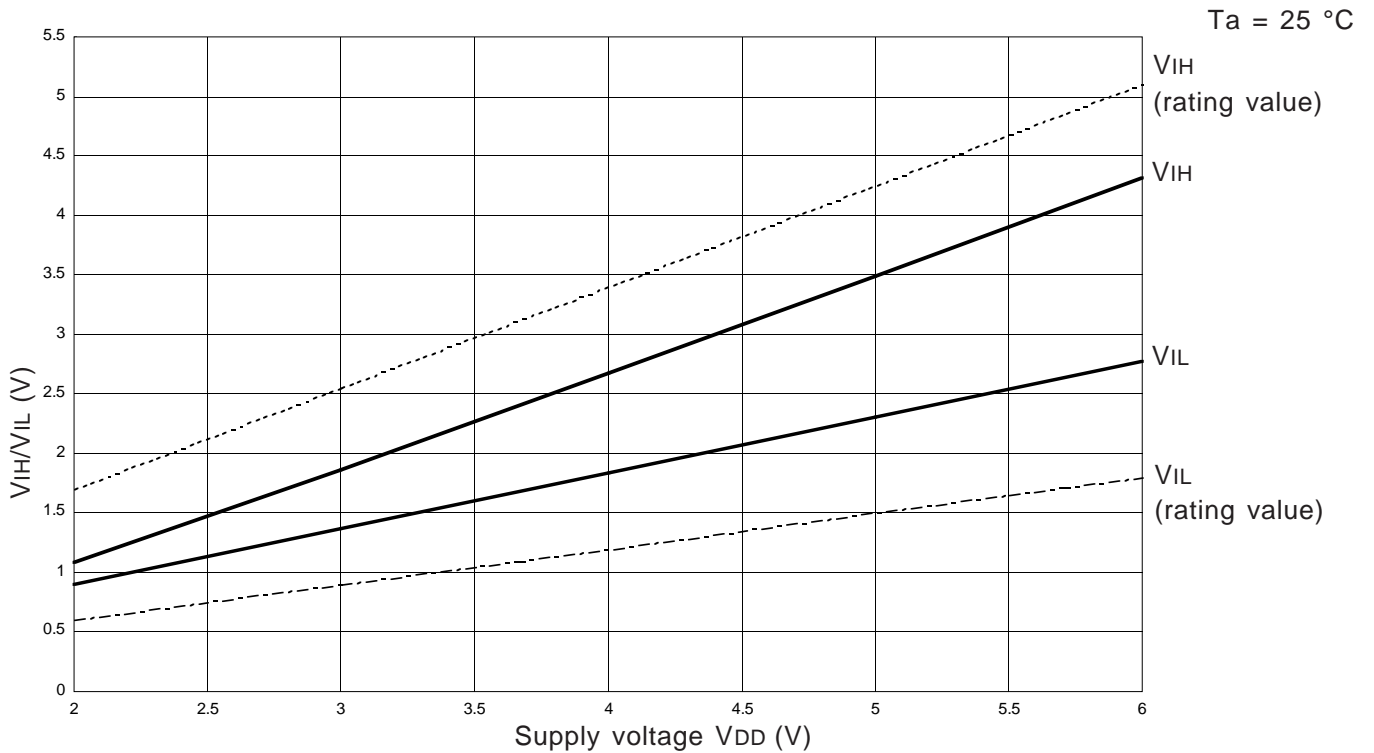

(2) Ports P0, P1, P2, P3, P4, P5, D, X_{IN} pin, VDCE pin

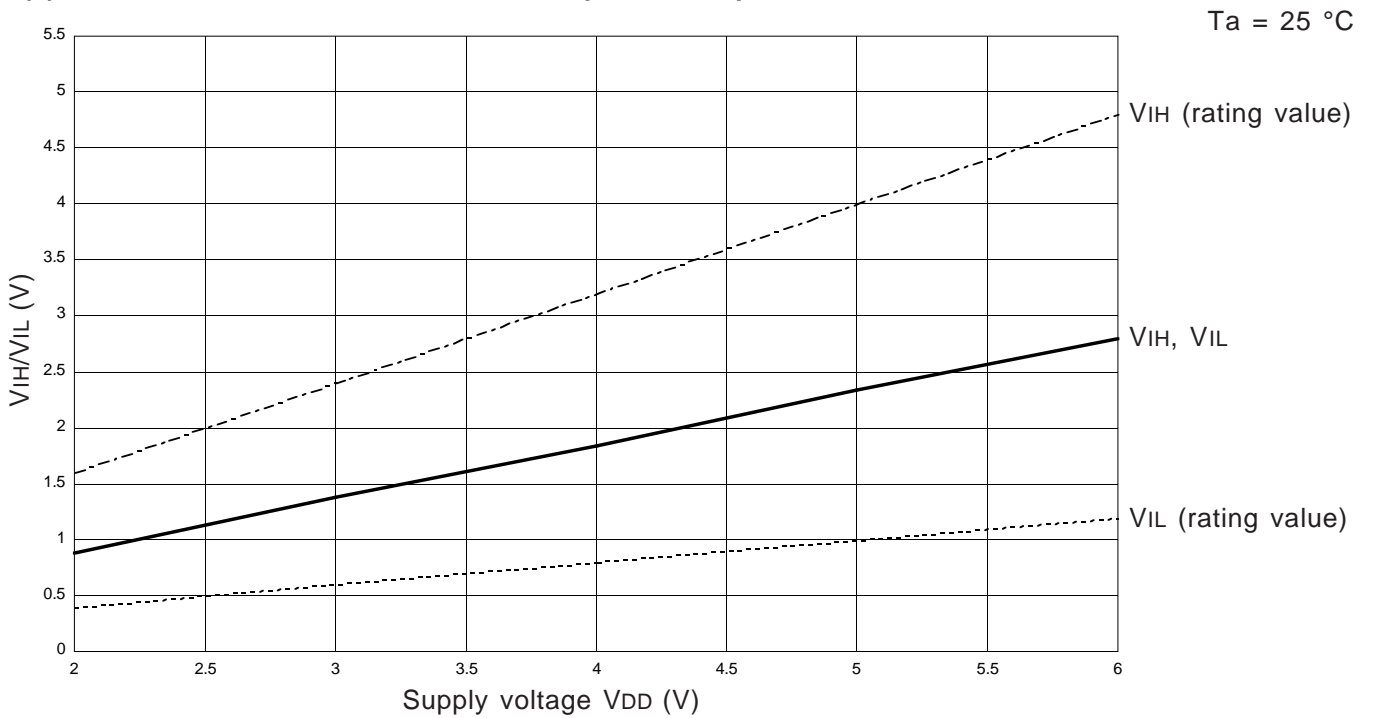

APPENDIX

3.2 Typical characteristics

(3) Pins INT0, INT1, CNTR0, CNTR1, Sck, SIN

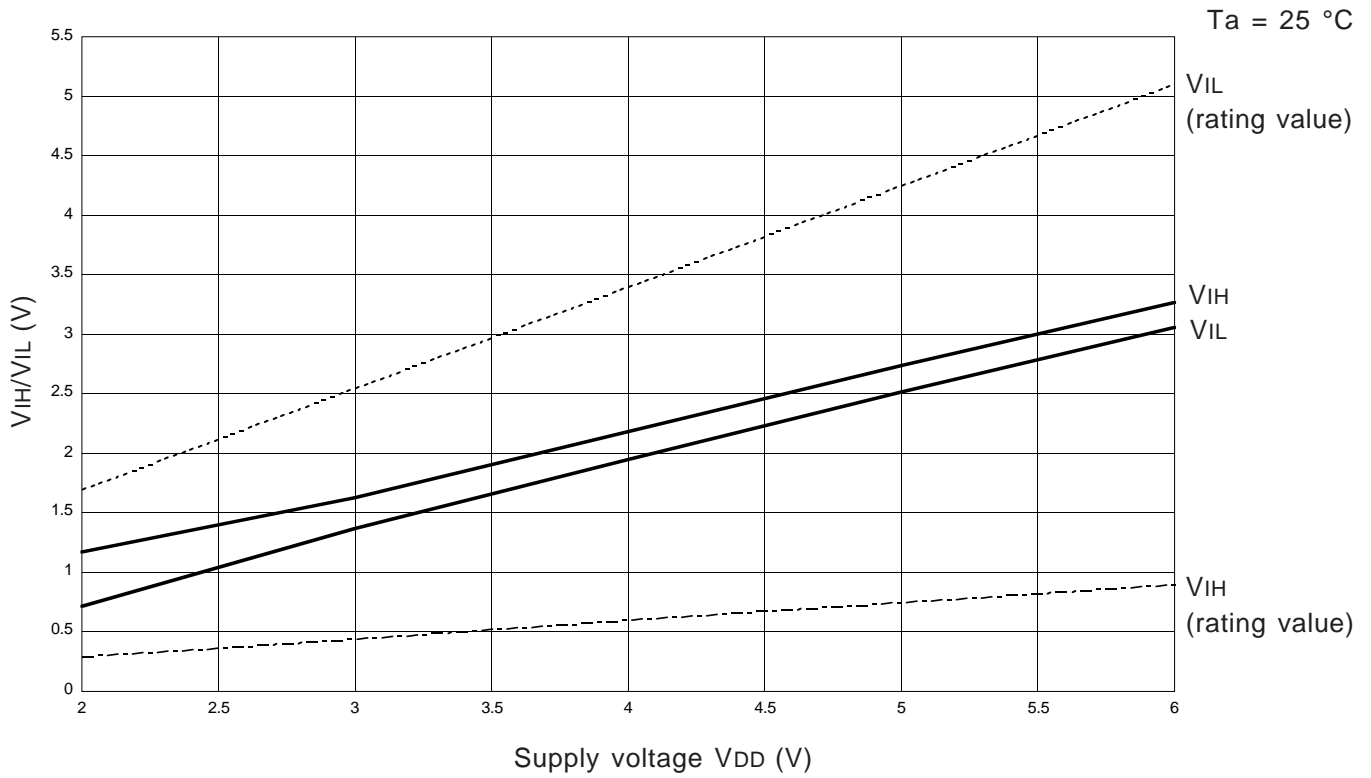

3.2.8 Detection voltage temperature characteristics of voltage drop detection circuit

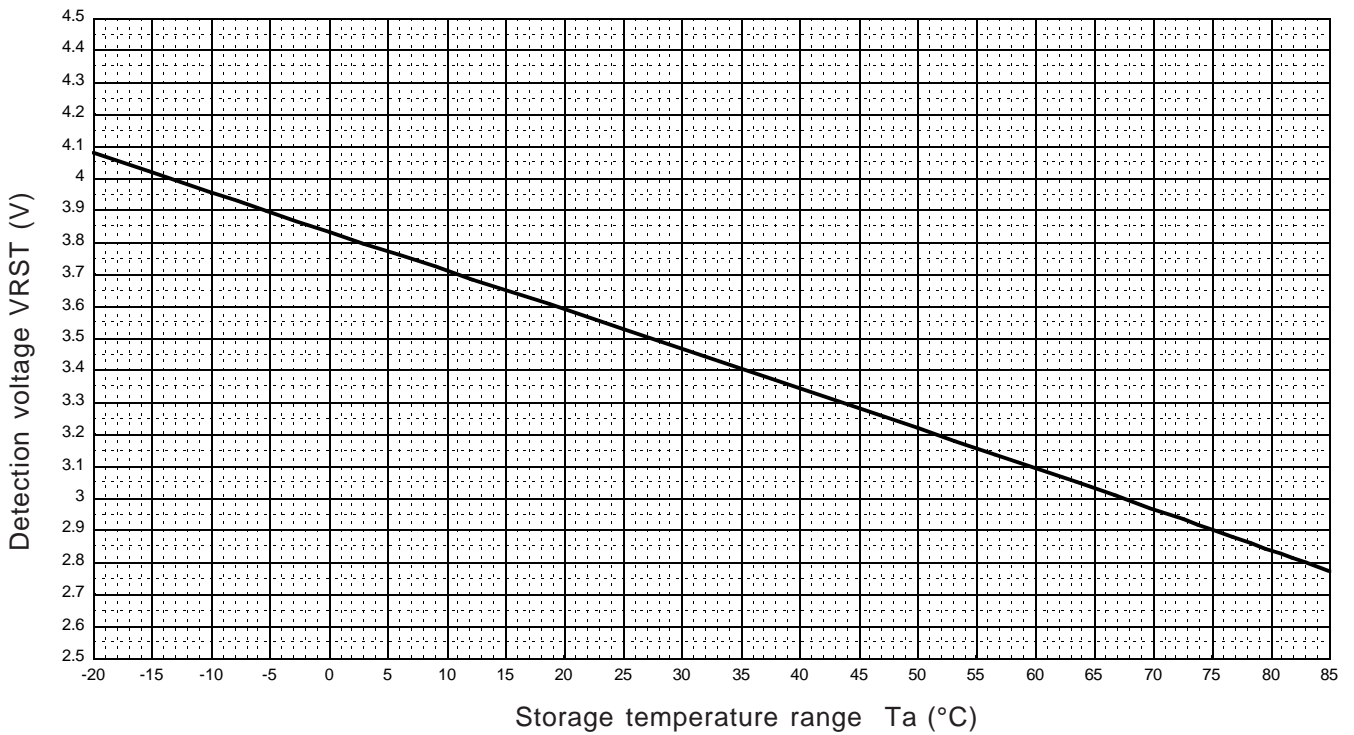

3.3 List of precautions

① Noise and latch-up prevention

Connect a capacitor on the following condition to prevent noise and latch-up;

- connect a bypass capacitor (approx. 0.1 μ F) between pins VDD and VSS at the shortest distance,
- equalize its wiring in width and length, and
- use relatively thick wire.

In the One Time PROM version, CNVSS pin is also used as VPP pin. Accordingly, when using this pin, connect this pin to VSS through a resistor about 5 k Ω in series at the shortest distance.

② Prescaler

Stop the prescaler operation to change its frequency dividing ratio.

③ Timer count source

Stop timer 1, 2, 3, or 4 counting to change its count source.

④ Reading the count value

Stop timer 1, 2, 3, or 4 counting and then execute the TAB1, TAB2, TAB3, or TAB4 instruction to read its data.

⑤ Writing to reload registers R1 and R3

When writing data to reload registers R1 or R3 while timer 1 or timer 3 is operating, avoid a timing when timer 1 or timer 3 underflows.

⑥ P30/INT0 pin

When the interrupt valid waveform of the P30/INT0 pin is changed with the bit 2 of register I1 in software, be careful about the following notes.

- Clear the bit 0 of register V1 to "0" before the interrupt valid waveform of P30/INT0 pin is changed with the bit 2 of register I1 (refer to Figure 44①).
- Depending on the input state of the P30/INT0 pin, the external 0 interrupt request flag (EXF0) may be set when the interrupt valid waveform is changed. Accordingly, clear bit 2 of register I1, and execute the SNZ0 instruction to clear the EXF0 flag after executing at least one instruction (refer to Figure 44②)

```

:
LA 4 ; (XXX02)
TV1A ; The SNZ0 instruction is valid ..... ①
LA 4 ;
TI1A ; Interrupt valid waveform is changed
NOP ..... ②
SNZ0 ; The SNZ0 instruction is executed
NOP
:
X : this bit is not related to the setting of INT0 pin.

```

Fig. 44 External 0 interrupt program example

⑦ P31/INT1 pin

When the interrupt valid waveform of P31/INT1 pin is changed with the bit 2 of register I2 in software, be careful about the following notes.

- Clear the bit 1 of register V1 to "0" before the interrupt valid waveform of P31/INT1 pin is changed with the bit 2 of register I2 (refer to Figure 45③).
- Depending on the input state of the P31/INT1 pin, the external 1 interrupt request flag (EXF1) may be set when the interrupt valid waveform is changed. Accordingly, clear bit 2 of register I2 and execute the SNZ1 instruction to clear the EXF1 flag after executing at least one instruction (refer to Figure 45④).

```

:
LA 8 ; (XX0X2)
TV1A ; The SNZ1 instruction is valid ..... ③
LA 8
TI2A ; Change of the interrupt valid waveform
NOP ..... ④
SNZ1 ; The SNZ1 instruction is executed
NOP
:
X : this bit is not related to the setting of INT1.

```

Fig. 45 External 1 interrupt program example

⑧ One Time PROM version

The operating power voltage of the One Time PROM version is 2.5 V to 5.5 V.

⑨ Multifunction

The input of D6, D7, P20–P22, I/O of P30 and P31, input of CMP0-, CMP0+, CMP1-, CMP1+, and I/O of P40–P43 can be used even when CNTR0, CNTR1, SCK, SOUT, SIN, INT0, INT1, AIN0–AIN3 and AIN4–AIN7 are selected.

APPENDIX

3.3 List of precautions

⑩ A-D converter-1

When the operating mode of the A-D converter is changed from the comparator mode to the A-D conversion mode with the bit 3 of register Q2 in a program, be careful about the following notes.

- Clear the bit 2 of register V2 to "0" to change the operating mode of the A-D converter from the comparator mode to the A-D conversion mode with the bit 3 of register Q2 (refer to Figure 46⑤).
- The A-D conversion completion flag (ADF) may be set when the operating mode of the A-D converter is changed from the comparator mode to the A-D conversion mode. Accordingly, set a value to register Q2, and execute the SNZAD instruction to clear the ADF flag.

Do not change the operating mode (both A-D conversion mode and comparator mode) of A-D converter with the bit 3 of register Q2 during operating the A-D converter.

```

:
LA 8 ; (X0XX2)
TV2A ; The SNZAD instruction is valid .....⑤
LA 0 ; (0XXX2)
TQ2A ; Change of the operating mode of the A-D
      ; converter from the comparator mode to the
      ; A-D conversion mode

SNZAD
NOP
:
X: this bit is not related to the change of the
    operating mode of the A-D conversion.
    
```

Fig. 46 A-D converter operating mode program example

⑪ A-D converter-2

Each analog input pin is equipped with a capacitor which is used to compare the analog voltage. Accordingly, when the analog voltage is input from the circuit with high-impedance and, charge/discharge noise is generated and the sufficient A-D accuracy may not be obtained. Therefore, reduce the impedance or, connect a capacitor (0.01 μF to 1 μF) to analog input pins (Figure 47).

When the overvoltage applied to the A-D conversion circuit may occur, connect an external circuit in order to keep the voltage within the rated range as shown the Figure 48. In addition, test the application products sufficiently.

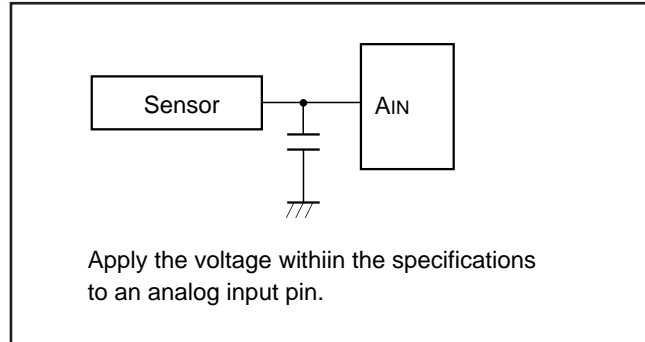

Fig. 47 Analog input external circuit example-1

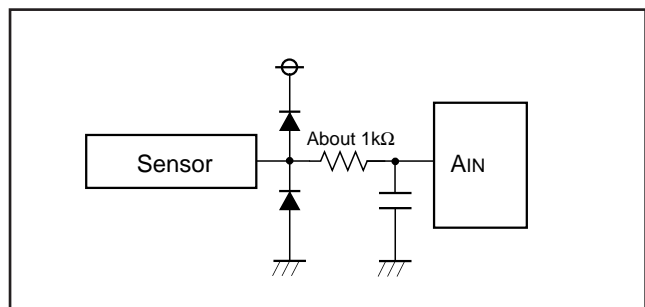

Fig. 48 Analog input external circuit example-2

⑫ POF instruction

Execute the POF instruction immediately after executing the EPOF instruction to enter the RAM back-up.

Note that system cannot enter the RAM back-up state when executing only the POF instruction.

Be sure to disable interrupts by executing the DI instruction before executing the EPOF instruction.

⑬ Analog input pins

Note the following when using the analog input pins also for I/O port P4 functions:

- Even when P40/AIN4–P43/AIN7 are set to pins for analog input, they continue to function as P40–P43 I/O. Accordingly, when any of them are used as I/O port P4 and others are used as analog input pins, make sure to set the outputs of pins that are set for analog input to "1." Also, the port input function of the pin functions as an analog input is undefined.
- TALA instruction
When the TALA instruction is executed, the low-order 2 bits of register AD is transferred to the high-order 2 bits of register A, simultaneously, the low-order 2 bits of register A is "0."

⑭ Program counter

Make sure that the PCH does not specify after the last page of the built-in ROM.

⑮ Port P3

In the 4513 Group, when the IAP3 instruction is executed, note that the high-order 2 bits of register A is undefined.

⑬ Voltage comparator function

When the voltage comparator function is valid with the voltage comparator control register Q3, it is operating even in the RAM back-up mode. Accordingly, be careful about such state because it causes the increase of the operation current in the RAM back-up mode.

In order to reduce the operation current in the RAM back-up mode, invalidate (bits 2 and 3 of register Q3 = "0") the voltage comparator function by software before the POF instruction is executed.

Also, while the voltage comparator function is valid, current is always consumed by voltage comparator. On the system required for the low-power dissipation, invalidate the voltage comparator when it is unused by software.

⑭ Register Q3

Bits 0 and 1 of register Q3 can be only read. Note that they cannot be written.

⑮ Reading the comparison result of voltage comparator

Read the voltage comparator comparison result from register Q3 after the voltage comparator response time (max. 20 μ s) is passed from the voltage comparator function become valid.

APPENDIX

3.4 Notes on noise

3.4 Notes on noise

Countermeasures against noise are described below. The following countermeasures are effective against noise in theory, however, it is necessary not only to take measures as follows but to evaluate before actual use.

3.4.1 Shortest wiring length

The wiring on a printed circuit board can function as an antenna which feeds noise into the microcomputer.

The shorter the total wiring length (by mm unit), the less the possibility of noise insertion into a microcomputer.

(1) Package

Select the smallest possible package to make the total wiring length short.

● Reason

The wiring length depends on a microcomputer package. Use of a small package, for example QFP and not DIP, makes the total wiring length short to reduce influence of noise.

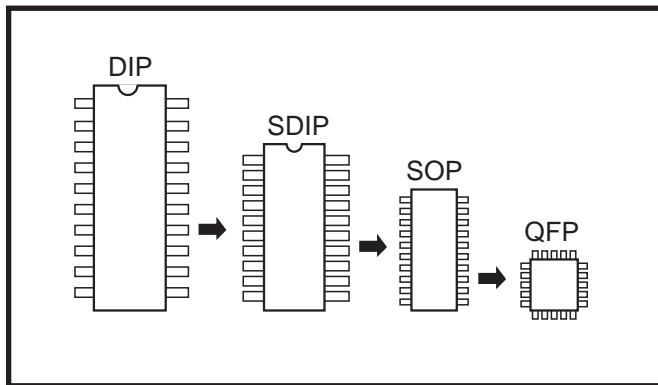

Fig. 3.4.1 Selection of packages

(2) Wiring for $\overline{\text{RESET}}$ input pin

Make the length of wiring which is connected to the $\overline{\text{RESET}}$ input pin as short as possible. Especially, connect a capacitor across the $\overline{\text{RESET}}$ input pin and the Vss pin with the shortest possible wiring.

● Reason

In order to reset a microcomputer correctly, 1 machine cycle or more of the width of a pulse input into the $\overline{\text{RESET}}$ pin is required. If noise having a shorter pulse width than this is input to the $\overline{\text{RESET}}$ input pin, the reset is released before the internal state of the microcomputer is completely initialized. This may cause a program runaway.

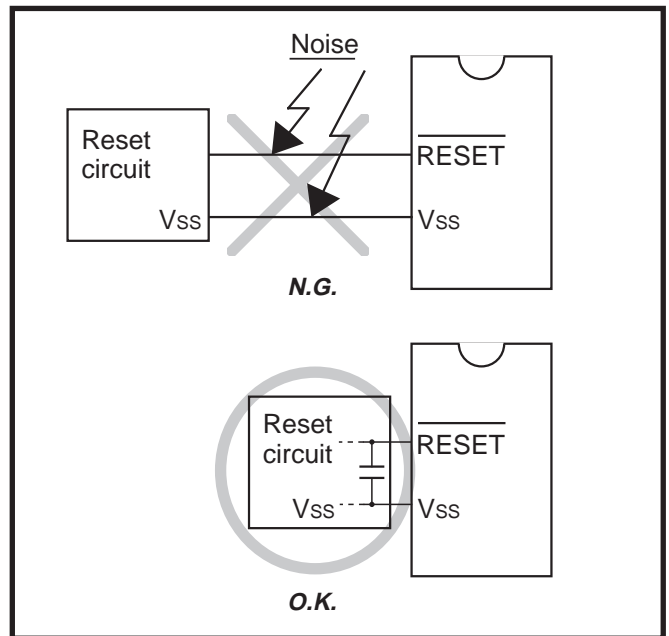

Fig. 3.4.2 Wiring for the $\overline{\text{RESET}}$ input pin

(3) Wiring for clock input/output pins

- Make the length of wiring which is connected to clock I/O pins as short as possible.
- Make the length of wiring across the grounding lead of a capacitor which is connected to an oscillator and the Vss pin of a microcomputer as short as possible.
- Separate the Vss pattern only for oscillation from other Vss patterns.

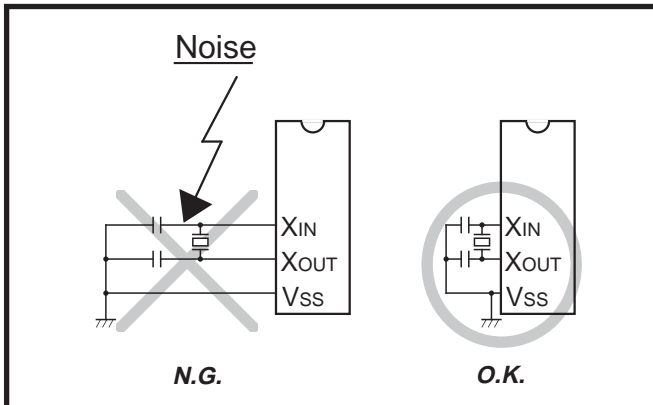

Fig. 3.4.3 Wiring for clock I/O pins

● Reason

If noise enters clock I/O pins, clock waveforms may be deformed. This may cause a program failure or program runaway. Also, if a potential difference is caused by the noise between the Vss level of a microcomputer and the Vss level of an oscillator, the correct clock will not be input in the microcomputer.

(4) Wiring to CNVss pin

Connect the CNVss pin to the Vss pin with the shortest possible wiring.

● Reason

The operation mode of a microcomputer is influenced by a potential at the CNVss pin. If a potential difference is caused by the noise between pins CNVss and Vss, the operation mode may become unstable. This may cause a microcomputer malfunction or a program runaway.

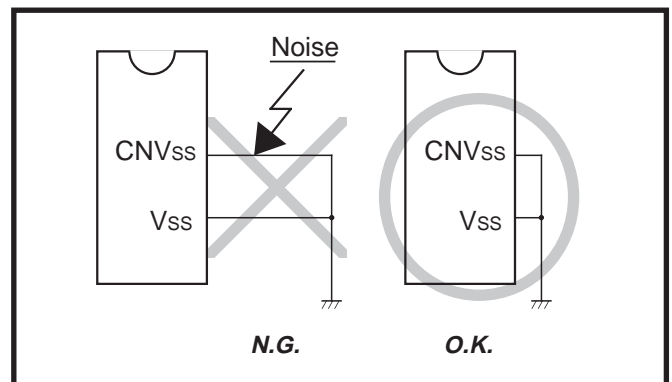

Fig. 3.4.4 Wiring for CNVss pin

APPENDIX

3.4 Notes on noise

(5) Wiring to VPP pin of One Time PROM version

In the built-in PROM version of the 4513/4514 Group, the CNVSS pin is also used as the built-in PROM power supply input pin VPP.

● When the VPP pin is also used as the CNVSS pin

Connect an approximately 5 kΩ resistor to the VPP pin the shortest possible in series and also to the VSS pin. When not connecting the resistor, make the length of wiring between the VPP pin and the VSS pin the shortest possible (refer to **Figure 3.4.5**)

Note: Even when a circuit which included an approximately 5 kΩ resistor is used in the Mask ROM version, the microcomputer operates correctly.

● Reason

The VPP pin of the One Time PROM version is the power source input pin for the built-in PROM. When programming in the built-in PROM, the impedance of the VPP pin is low to allow the electric current for writing flow into the PROM. Because of this, noise can enter easily. If noise enters the VPP pin, abnormal instruction codes or data are read from the built-in PROM, which may cause a program runaway.

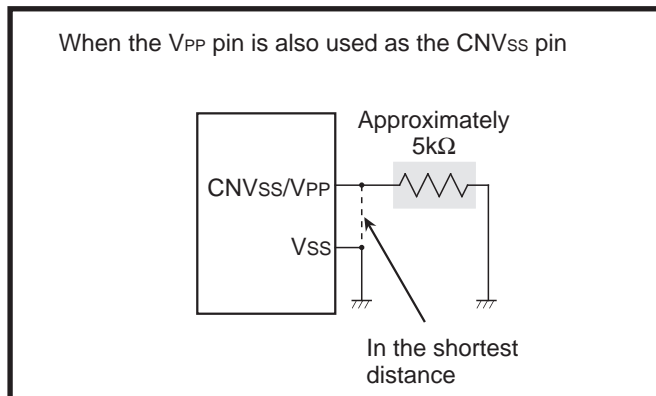

Fig. 3.4.5 Wiring for the VPP pin of the One Time PROM version

3.4.2 Connection of bypass capacitor across VSS line and VDD line

Connect an approximately 0.1 μF bypass capacitor across the VSS line and the VDD line as follows:

- Connect a bypass capacitor across the VSS pin and the VDD pin at equal length.
- Connect a bypass capacitor across the VSS pin and the VDD pin with the shortest possible wiring.
- Use lines with a larger diameter than other signal lines for VSS line and VDD line.
- Connect the power source wiring via a bypass capacitor to the VSS pin and the VDD pin.

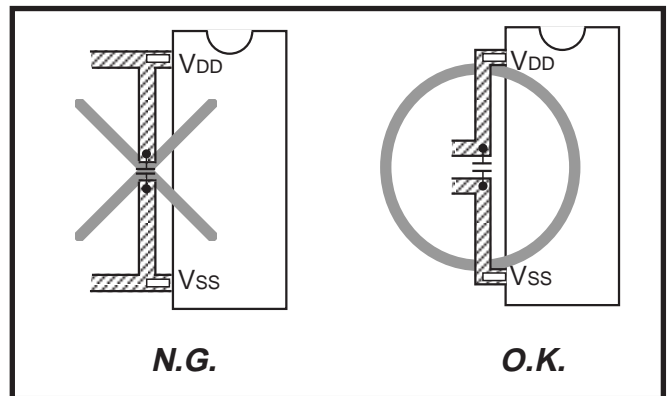

Fig. 3.4.6 Bypass capacitor across the VSS line and the VDD line

3.4.3 Wiring to analog input pins

- Connect an approximately 100 Ω to 1 k Ω resistor to an analog signal line which is connected to an analog input pin in series. Besides, connect the resistor to the microcomputer as close as possible.
- Connect an approximately 1000 pF capacitor across the Vss pin and the analog input pin. Besides, connect the capacitor to the Vss pin as close as possible. Also, connect the capacitor across the analog input pin and the Vss pin at equal length.

● Reason

Signals which is input in an analog input pin (such as an A-D converter/comparator input pin) are usually output signals from sensor. The sensor which detects a change of event is installed far from the printed circuit board with a microcomputer, the wiring to an analog input pin is longer necessarily. This long wiring functions as an antenna which feeds noise into the microcomputer, which causes noise to an analog input pin.

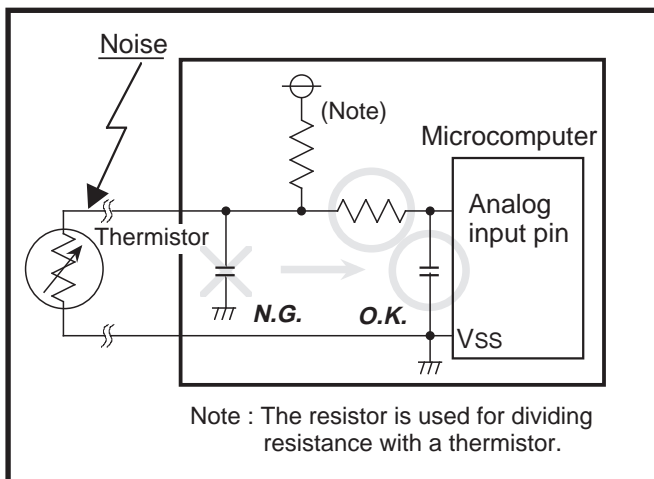

Fig. 3.4.7 Analog signal line and a resistor and a capacitor

3.4.4 Oscillator concerns

Take care to prevent an oscillator that generates clocks for a microcomputer operation from being affected by other signals.

(1) Keeping oscillator away from large current signal lines

Install a microcomputer (and especially an oscillator) as far as possible from signal lines where a current larger than the tolerance of current value flows.

● Reason

In the system using a microcomputer, there are signal lines for controlling motors, LEDs, and thermal heads or others. When a large current flows through those signal lines, strong noise occurs because of mutual inductance.

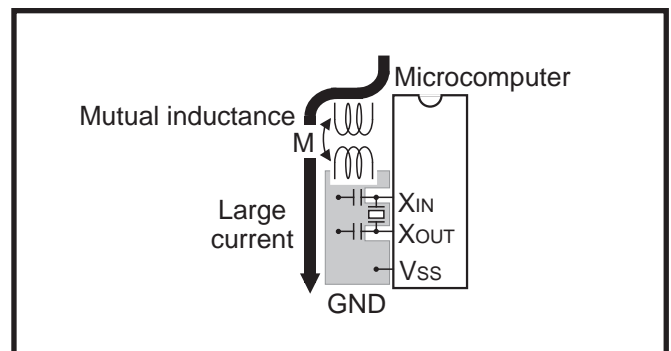

Fig. 3.4.8 Wiring for a large current signal line

(2) Installing oscillator away from signal lines where potential levels change frequently

Install an oscillator and a connecting pattern of an oscillator away from signal lines where potential levels change frequently. Also, do not cross such signal lines over the clock lines or the signal lines which are sensitive to noise.

● Reason

Signal lines where potential levels change frequently (such as the CNTR pin signal line) may affect other lines at signal rising edge or falling edge. If such lines cross over a clock line, clock waveforms may be deformed, which causes a microcomputer failure or a program runaway.

APPENDIX

3.4 Notes on noise

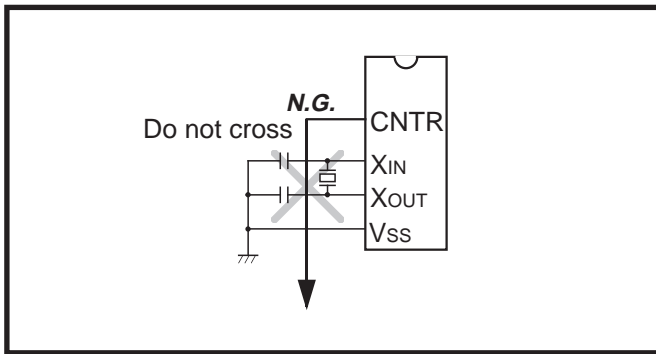

Fig. 3.4.9 Wiring to a signal line where potential levels change frequently

(3) Oscillator protection using Vss pattern

As for a two-sided printed circuit board, print a Vss pattern on the underside (soldering side) of the position (on the component side) where an oscillator is mounted.

Connect the Vss pattern to the microcomputer Vss pin with the shortest possible wiring. Besides, separate this Vss pattern from other Vss patterns.

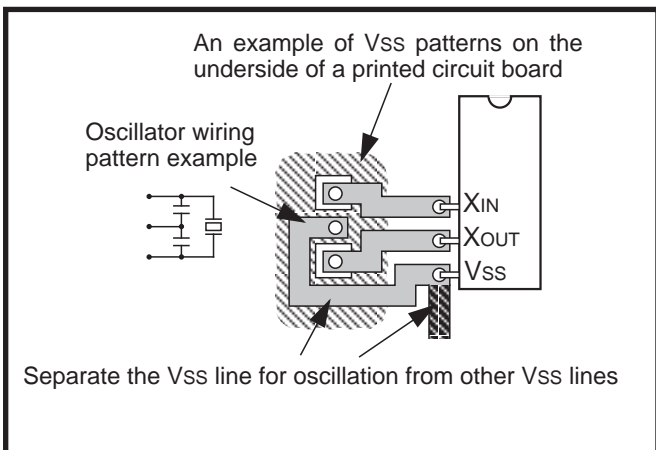

Fig. 3.4.10 Vss pattern on the underside of an oscillator

3.4.5 Setup for I/O ports

Setup I/O ports using hardware and software as follows:

<Hardware>

- Connect a resistor of 100 Ω or more to an I/O port in series.

<Software>

- As for an input port, read data several times by a program for checking whether input levels are equal or not.
- As for an output port or an I/O port, since the output data may reverse because of noise, rewrite data to its output latch at fixed periods.
- Rewrite data to pull-up control registers at fixed periods.

3.4.6 Providing of watchdog timer function by software

If a microcomputer runs away because of noise or others, it can be detected by a software watchdog timer and the microcomputer can be reset to normal operation. This is equal to or more effective than program runaway detection by a hardware watchdog timer. The following shows an example of a watchdog timer provided by software.

In the following example, to reset a microcomputer to normal operation, the main routine detects errors of the interrupt processing routine and the interrupt processing routine detects errors of the main routine. This example assumes that interrupt processing is repeated multiple times in a single main routine processing.

<The main routine>

- Assigns a single word of RAM to a software watchdog timer (SWDT) and writes the initial value N in the SWDT once at each execution of the main routine. The initial value N should satisfy the following condition:

$N+1 \geq$ (Counts of interrupt processing executed in each main routine)

As the main routine execution cycle may change because of an interrupt processing or others, the initial value N should have a margin.

- Watches the operation of the interrupt processing routine by comparing the SWDT contents with counts of interrupt processing after the initial value N has been set.
- Detects that the interrupt processing routine has failed and determines to branch to the program initialization routine for recovery processing in the following case:

If the SWDT contents do not change after interrupt processing.

<The interrupt processing routine>

- Decrements the SWDT contents by 1 at each interrupt processing.
- Determines that the main routine operates normally when the SWDT contents are reset to the initial value N at almost fixed cycles (at the fixed interrupt processing count).
- Detects that the main routine has failed and determines to branch to the program initialization routine for recovery processing in the following case:

If the SWDT contents are not initialized to the initial value N but continued to decrement and if they reach 0 or less.

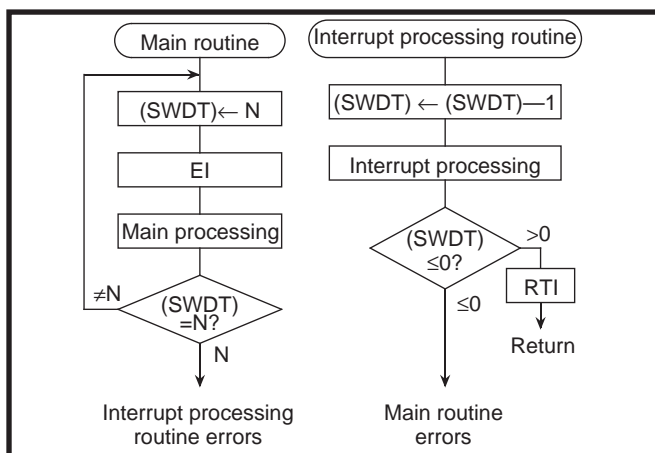

Fig. 3.4.11 Watchdog timer by software

APPENDIX

3.6 Mark specification form

3.6 Mark specification form

32P4B (32-PIN SHRINK DIP) MARK SPECIFICATION FORM

Mitsubishi IC catalog name

Please choose one of the marking types below (A, B, C), and enter the Mitsubishi IC catalog name and the special mark (if needed).

A. Standard Mitsubishi Mark

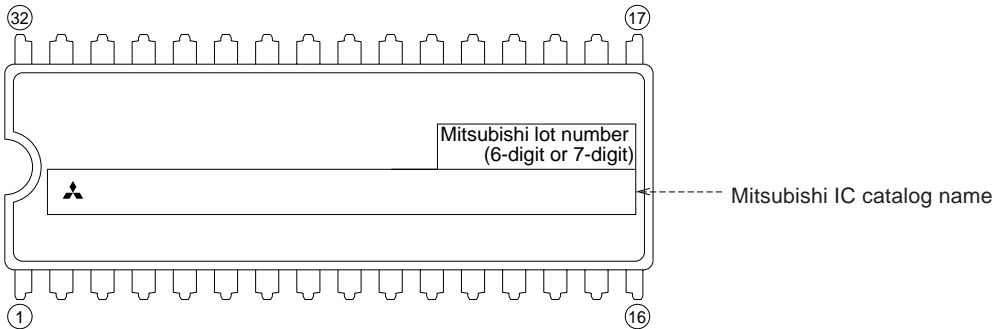

B. Customer's Parts Number + Mitsubishi catalog name

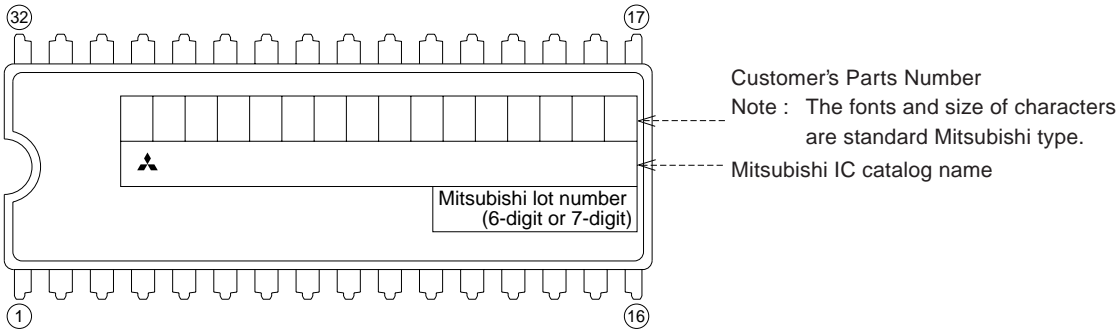

Note1 : The mark field should be written right aligned.

2 : The fonts and size of characters are standard Mitsubishi type.

3 : Customer's Parts Number can be up to 16 characters : Only 0 ~ 9, A ~ Z, +, -, /, (,), &, @, . (periods), and , (commas) are usable.

4 : If the Mitsubishi logo is not required, check the box on the right.

Mitsubishi logo is not required

C. Special Mark Required

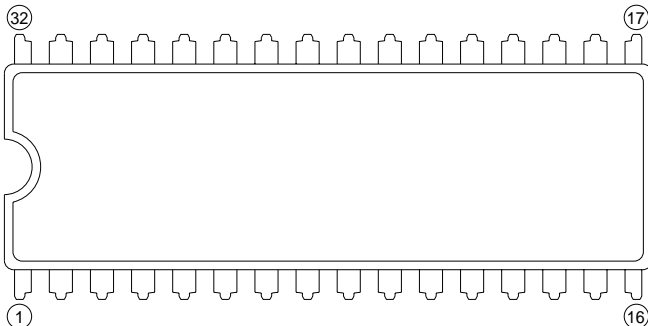

Note1 : If the Special Mark is to be Printed, indicate the desired layout of the mark in the upper figure. The layout will be duplicated as close as possible. Mitsubishi lot number (6-digit or 7-digit) and Mask ROM number (3-digit) are always marked.

2 : If the customer's trade mark logo must be used in the Special Mark, check the box on the right. Please submit a clean original of the logo. For the new special character fonts a clean font original (ideally logo drawing) must be submitted.

Special logo required

3 : The standard Mitsubishi font is used for all characters except for a logo.

32P6B (32-PIN LQFP) MARK SPECIFICATION FORM

Mitsubishi IC catalog name

Please choose one of the marking types below (A, B), and enter the Mitsubishi catalog name and the special mark (if needed).

A. Standard Mitsubishi Mark

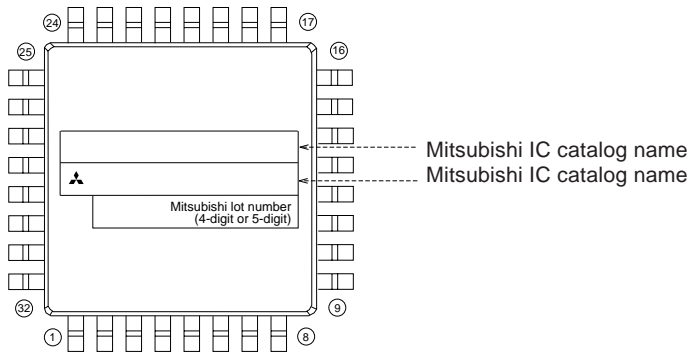

B. Customer's Parts Number + Mitsubishi catalog name

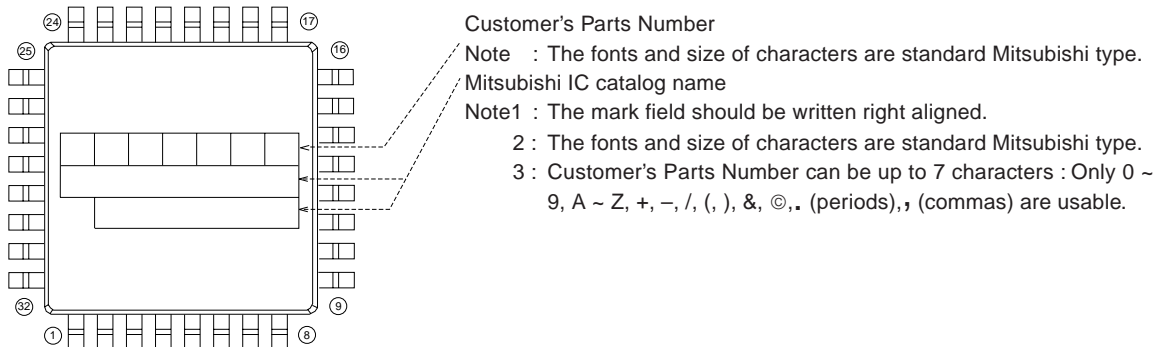

APPENDIX

3.6 Mark specification form

42P2R-A (42-PIN SHRINK SOP) MARK SPECIFICATION FORM

Mitsubishi IC catalog name

Please choose one of the marking types below (A, B, C), and enter the Mitsubishi catalog name and the special mark (if needed).

A. Standard Mitsubishi Mark

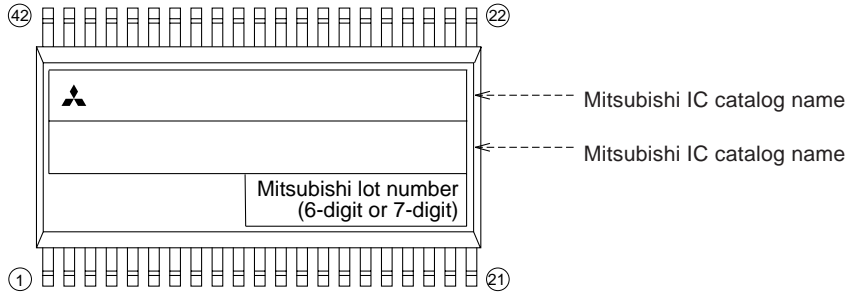

B. Customer's Parts Number + Mitsubishi catalog name

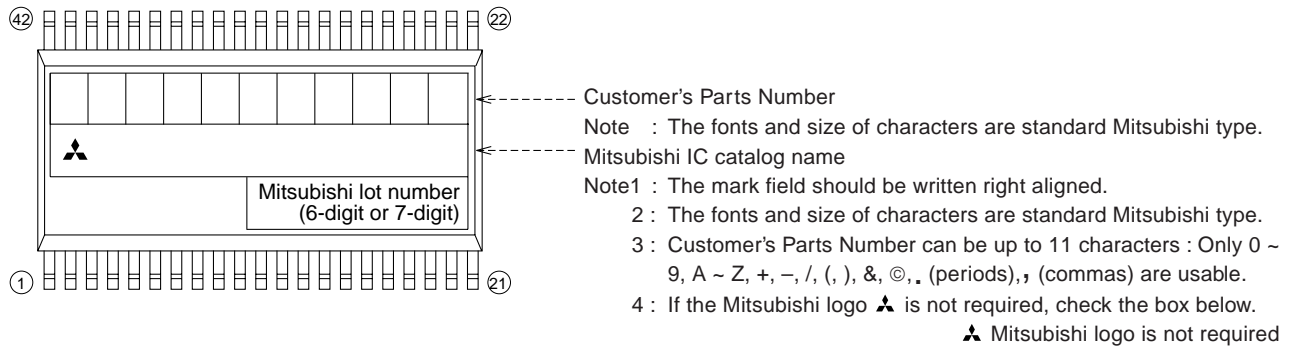

Mitsubishi logo is not required

C. Special Mark Required

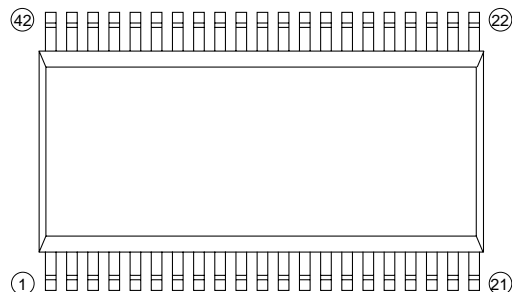

Note1 : If the Special Mark is to be Printed, indicate the desired layout of the mark in the left figure. The layout will be duplicated as close as possible.

Mitsubishi lot number (6-digit or 7-digit) and Mask ROM number (3-digit) are always marked.

2 : If the customer's trade mark logo must be used in the Special Mark, check the box below.

Please submit a clean original of the logo.

For the new special character fonts a clean font original (ideally logo drawing) must be submitted.

Special logo required

3.7 Package outline

32P4B

Plastic 32pin 400mil SDIP

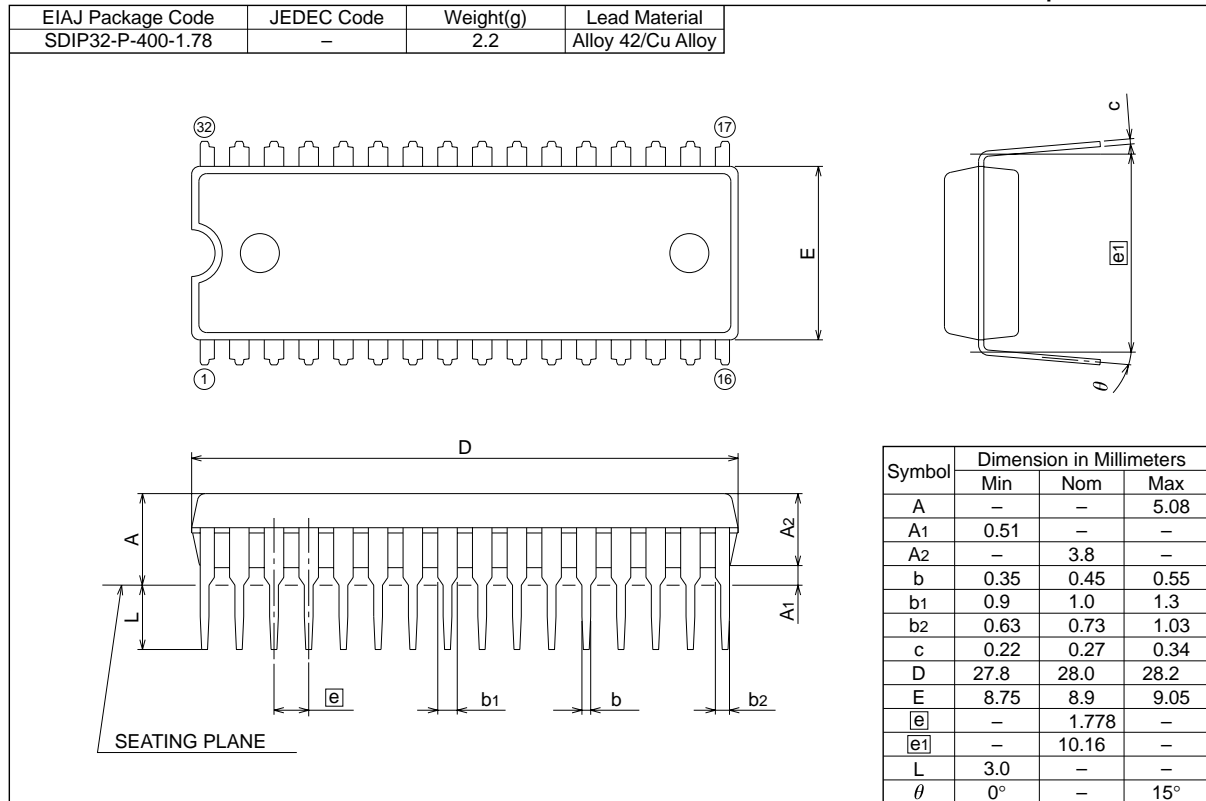

32P6B-A

Plastic 32pin 7X7mm body LQFP

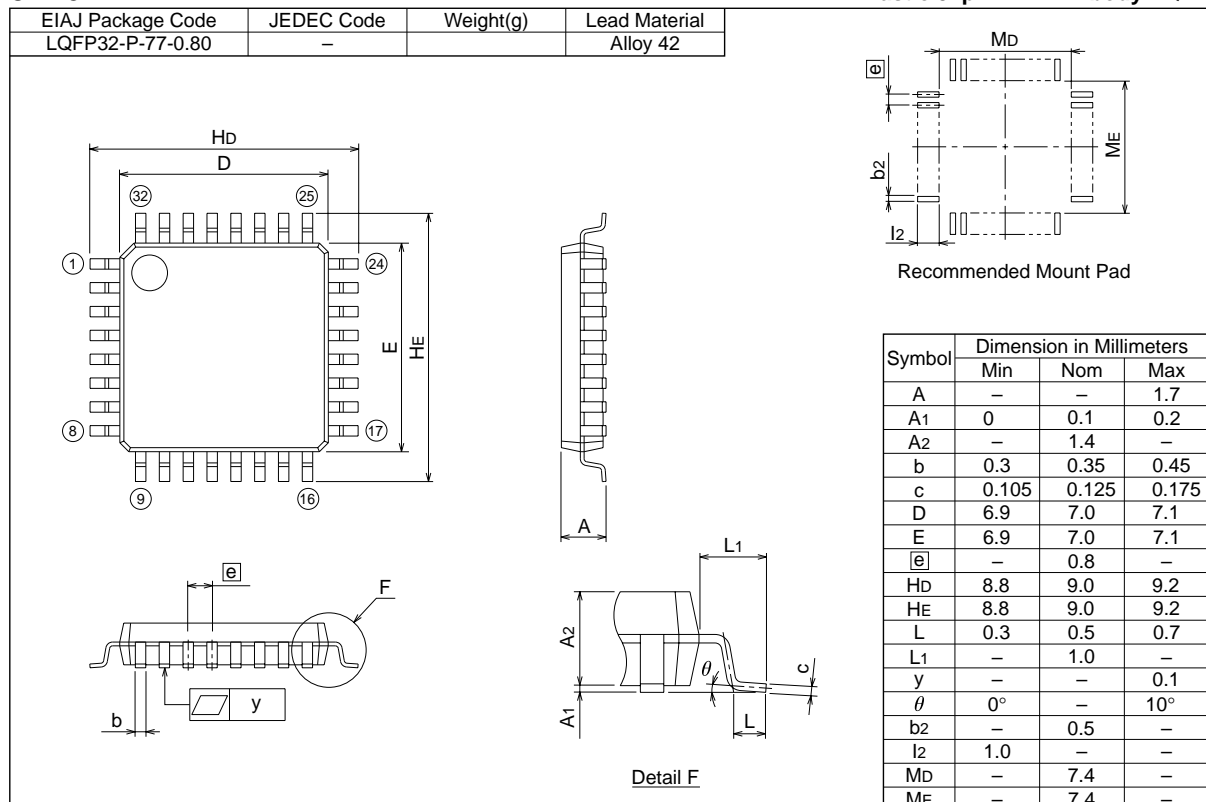

APPENDIX

3.7 Package outline

42P2R-A

Plastic 42pin 450mil SSOP

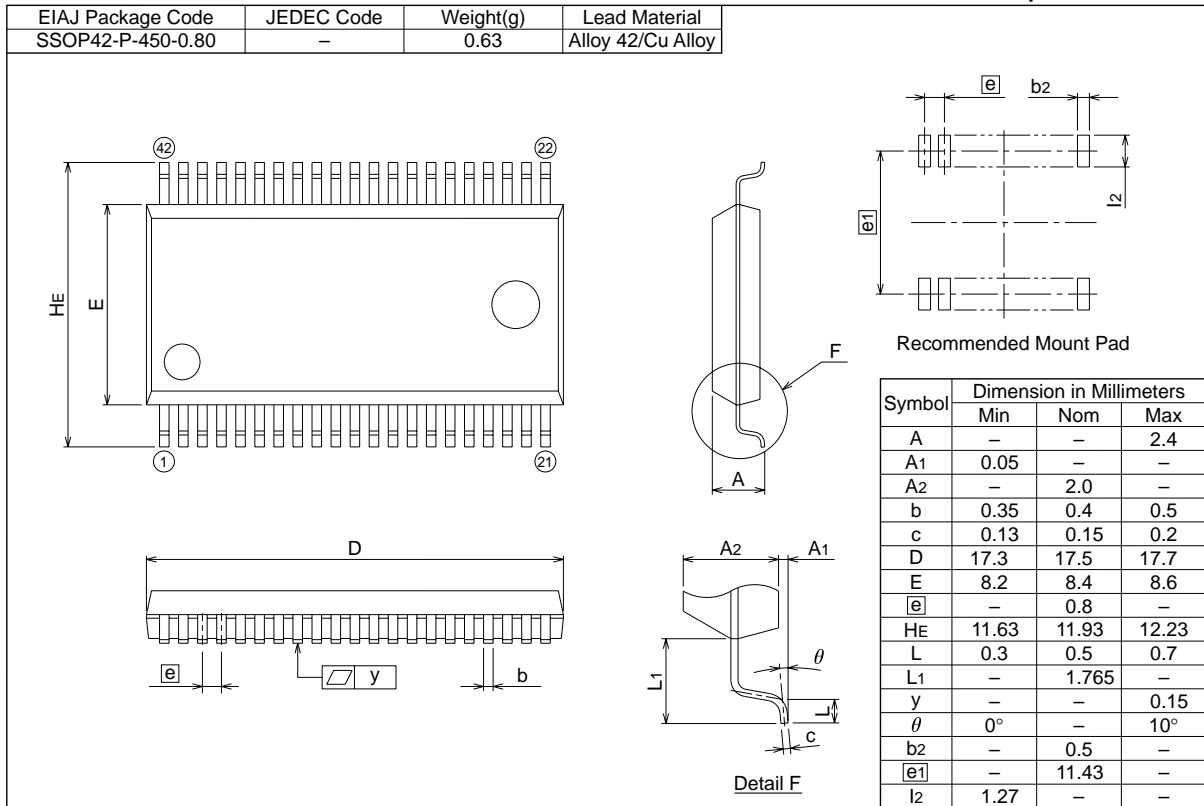

**MITSUBISHI SEMICONDUCTORS
USER'S MANUAL
4513/4514 Group**

Dec. First Edition 1998

Edited by
Committee of editing of Mitsubishi Semiconductor USER'S MANUAL

Published by
Mitsubishi Electric Corp., Semiconductor Marketing Division

This book, or parts thereof, may not be reproduced in any form without permission of Mitsubishi Electric Corporation.

©1998 MITSUBISHI ELECTRIC CORPORATION

REVISION DESCRIPTION LIST

4513/4514 GROUP USER'S MANUAL

Rev. No.	Revision Description	Rev. date
1.0	First Edition	981211

User's Manual
4513/4514 Group

Renesas Technology Corp.
Nippon Bldg.,6-2,Otemachi 2-chome,Chiyoda-ku,Tokyo,100-0004 Japan