

User Manual

HandyTone-386

Analog Telephone Adaptor

For Firmware Release Version 1.0.3.44



Grandstream Networks, Inc.

www.grandstream.com

Table of Contents

1	WELCOME	4
2	INSTALLATION.....	5
3	WHAT IS INCLUDED IN THE PACKAGE.....	7
3.1	SAFETY COMPLIANCES	7
3.2	WARRANTY	7
4	PRODUCT OVERVIEW.....	8
4.1	KEY FEATURES.....	8
4.2	HARDWARE SPECIFICATION	9
5	BASIC OPERATIONS	10
5.1	GET FAMILIAR WITH VOICE PROMPT.....	10
5.2	MAKE PHONE CALLS.....	11
5.2.1	Calling phone or extension numbers	11
5.2.2	Direct IP calls	11
5.2.3	Call Hold.....	12
5.2.4	Call Waiting.....	12
5.2.5	Call Transfer	12
5.2.6	3-way Conferencing.....	13
5.2.6.1	Star code style 3-way Conferencing.....	13
5.2.6.2	Bellcore Style 3-way Conference.....	14
5.2.7	PSTN Pass Through.....	14
5.3	CALL FEATURES	14
5.3.1	Call Features Table (Star Code)	14
5.3.2	PSTN Pass Through / Life Line.....	15
5.4	FAX SUPPORT	15
5.5	LED LIGHT PATTERN INDICATION	16
6	CONFIGURATION GUIDE	17
6.1	CONFIGURING HANDYTONE-386 LAN IP THROUGH VOICE PROMPT.....	17
6.1.1	DHCP Mode	17
6.1.2	STATIC IP Mode	17
6.1.3	TFTP Server Address	17
6.2	CONFIGURING HANDYTONE-386 WITH WEB BROWSER	17
6.2.1	Access the Web Configuration Menu.....	17
6.2.2	End User Configuration	18
6.2.3	Advanced Configuration and FXS ports Parameters.....	23
6.2.4	Saving the Configuration Changes	36
6.2.5	Rebooting the HandyTone-386 from Remote	36
6.3	CONFIGURATION THROUGH A CENTRAL SERVER.....	37
7	SOFTWARE UPGRADE	38
7.1	FIRMWARE UPGRADE THROUGH TFTP/HTTP.....	38

7.2	CONFIGURATION FILE DOWNLOAD	39
7.3	FIRMWARE AND CONFIGURATION FILE PREFIX AND POSTFIX.....	39
7.4	MANAGING FIRMWARE AND CONFIGURATION FILE DOWNLOAD	39
8	RESTORE FACTORY DEFAULT SETTING.....	40
9	GLOSSARY.....	41

1 Welcome

Congratulations on becoming an owner of HandyTone-386. You made an excellent choice and we hope you enjoy all of its capabilities.

Grandstream's HandyTone-386 is an all-in-one VoIP integrated access device that features superb audio quality, rich functionalities, high level of integration, compactness and ultra-affordability. The HandyTone-386 is fully compatible with SIP industry standard and can interoperate with many other SIP compliant devices and software on the market.

Grandstream HandyTone-386 is another addition to the popular HandyTone product family. The HandyTone-386 features two FXS ports each with independent SIP accounts.

This document is subject to changes without notice. The latest electronic version of this user manual can be downloaded from the following location:

<http://www.grandstream.com/y-downloads.htm>

2 Installation

HandyTone-386 Analog Telephone Adaptor is an all-in-one VoIP integrated device designed to be a total solution for networks providing VoIP services.

The HandyTone-386 VoIP functionalities are available via regular analog telephones. The following photo illustrates the appearance of a HandyTone-386.

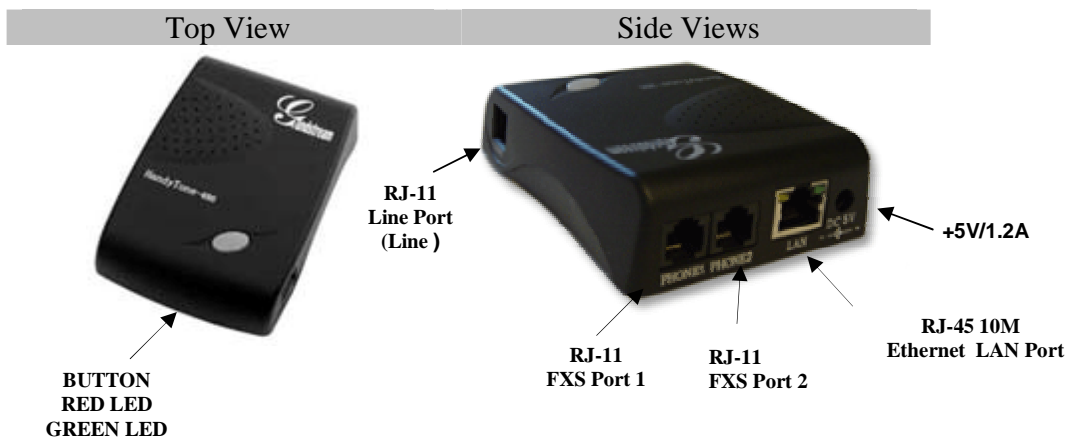

Interconnection Diagram of the HandyTone-386:

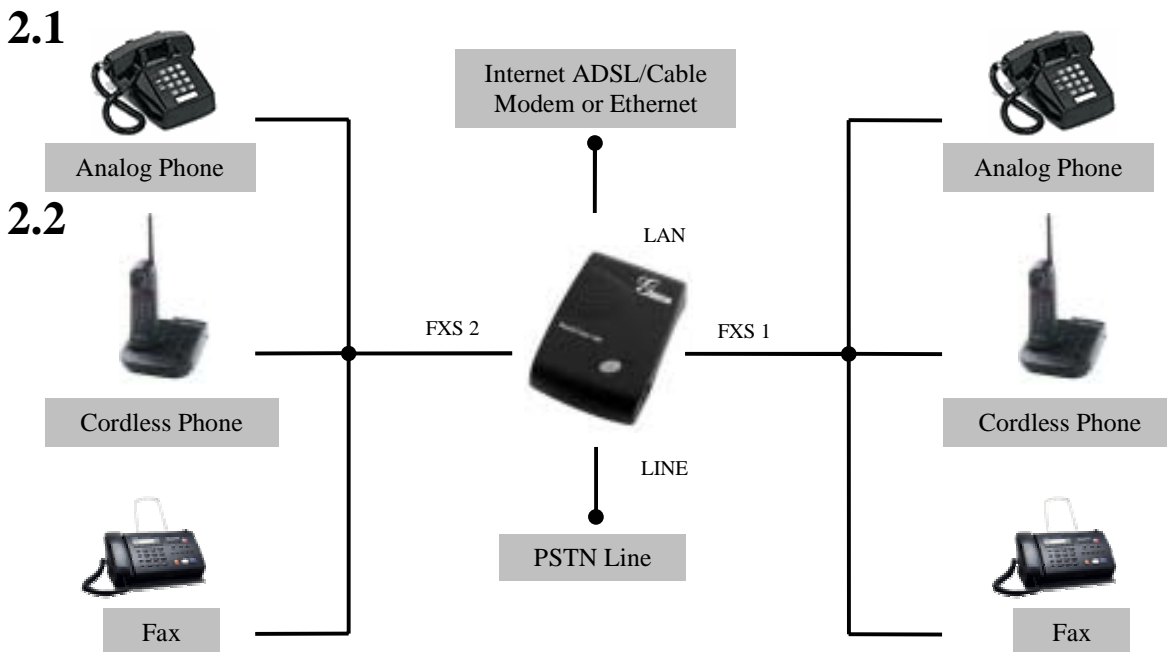

HandyTone-386 has two FXS ports. The RJ-11 jack next to the LAN is called FXS port 2 and the RJ-11 jack on the corner is called FXS port 1. The RJ-11 jack on the side on of the HandyTone-386 is a LINE port or PSTN pass-through port. Each FXS port can have a separate SIP account. This is a key feature of HandyTone-386. Both ports can make calls concurrently.

Following are the steps to install a HandyTone-386:

1. Connect a standard touch-tone analog telephone (or fax machine) to FXS port 1.
2. Connect another standard touch-tone analog telephone (or fax machine) to FXS port 2.
3. Insert a standard telephone cable into the LINE port of HandyTone-386 and connect the other end of the telephone cable to a wall jack.
4. Insert the Ethernet cable into the LAN port of HandyTone-386 and connect the other end of the Ethernet cable to an uplink port (a router or a modem, etc.)
5. Insert the power adapter into the HandyTone-386 and connect it to a wall outlet.

Please follow the instructions in section 6.2.1 to configure the HandyTone-386.

3 What is Included in the Package

The HandyTone-386 package contains:

- 1) One HandyTone-386
- 2) One universal power adaptor
- 3) One Ethernet cable

3.1 Safety Compliances

The HandyTone-386 is compliant with various safety standards including FCC/CE and C-tick. Its power adaptor is compliant with UL standard. The HandyTone-386 should only operate with the universal power adaptor provided in the package.

3.2 Warranty

Grandstream has a reseller agreement with our reseller customer. End users should contact the company from whom you purchased the product for replacement, repair or refund.

If you purchased the product directly from Grandstream, contact your Grandstream Sales and Service Representative for a RMA (Return Materials Authorization) number.

Grandstream reserves the right to remedy warranty policy without prior notification.

Warning: Please do not attempt to use a different power adaptor. Using other power adaptor may damage the HandyTone-386 and will void the manufacturer warranty.

Caution: Changes or modifications to this product not expressly approved by Grandstream, or operation of this product in any way other than as detailed by this User Manual, could void your manufacturer warranty.

Information in this document is subject to change without notice. No part of this document may be reproduced or transmitted in any form or by any means, electronic or mechanical, for any purpose without the express written permission of Grandstream Networks, Inc..

4 Product Overview

4.1 Key Features

- Supports SIP 2.0(RFC 3261), TCP/UDP/IP, RTP/RTCP, HTTP, ICMP, ARP/RARP, DNS, DHCP (both client and server), NTP, PPPoE, STUN, TFTP, etc.
- Supports dual SIP accounts via dual FXS ports
- Powerful digital signal processing (DSP) to ensure superb audio quality; advanced adaptive jitter control and packet loss concealment technology
- Support various codecs including G.711 (PCM a-law and u-law), G.723.1 (5.3K/6.3K), G.726 (32K), as well as G.729A, and iLBC.
- Support Caller ID/name display or block, Call waiting caller ID, Hold, Call Waiting/Flash, Call Transfer, Call Forward, 3-way conferencing, in-band and out-of-band DTMF, etc.
- Support fax pass through (for PCMU and PCMA) and T.38 FoIP (Fax over IP).
- Support syslog
- Support Silence Suppression, VAD (Voice Activity Detection), CNG (Comfort Noise Generation), Line Echo Cancellation (G.168), and AGC (Automatic Gain Control)
- Support standard encryption and authentication (DIGEST using MD5 and MD5-sess)
- Support for Layer 2 (802.1Q VLAN, 802.1p) and Layer 3 QoS (ToS, DiffServ, MPLS)
- Support automated NAT traversal without manual manipulation of firewall/NAT
- Support device configuration via built-in IVR, Web browser or Central configuration files through TFTP or HTTP server
- Support firmware upgrade via TFTP or HTTP.
- Support PSTN pass through.
- Ultra compact (wallet size) and lightweight design, great companion for travelers.
- Compact, lightweight Universal Power adapter.

4.2 Hardware Specification

The table below lists the hardware specification of HandyTone-386.

<u>Model</u>	<u>HandyTone-386</u>
LAN interface	1xRJ45 10Base-T
FXS telephone port	2 x FXS
PSTN Port	1x PSTN pass-through or life line port
Button	1
LED	Green and Red color
Universal Switching Power Adaptor	Input: 100-240VAC 50-60 Hz Output: +5VDC, 1200mA UL certified
Dimension	70mm (W) 130mm (D) 27mm (H)
Weight	0.6lbs (0.3kg)
Temperature	40 - 130°F 5 - 45°C
Humidity	10% - 90% (non-condensing)
Compliance	

5 Basic Operations

5.1 Get Familiar with Voice Prompt

HandyTone-386 has a stored voice prompt menu for quick browsing and simple configuration. Currently, the voice prompt menu and the LED button is designed for **FXS port 1 ONLY**.

To enter this voice prompt menu, simply **press the button or “****” from the analog phone**.

Menu	Voice Prompt	User's Options
Main Menu	“Enter a Menu Option”	Enter “*” for the next menu option Enter “#” to return to the main menu Enter 01 – 06, 47, 86 or 99 Menu option
01	“DHCP Mode”, “Static IP Mode”	Enter ‘9’ to toggle the selection <i>If user selects “Static IP Mode”, user need configure the all IP address information through menu 02 to 05. If user selects “Dynamic IP Mode”, the device will retrieve all IP address information from DHCP server automatically when user reboots the device.</i>
02	“IP Address “ + IP address	The current WAN IP address is announced Enter 12-digit new IP address if in Static IP Mode.
03	“Subnet “ + IP address	Same as menu 02
04	“Gateway “ + IP address	Same as menu 02
05	“DNS Server “ + IP address	Same as menu 02
06	“TFTP Server “ + IP address	Same as menu 02
47	“Direct IP Calling”	When entered, user will be prompted a dial tone, dial a 12-digit IP address to make a direct IP call. (For details, see “4.2.2 Make a Direct IP Call”.)
86	“Voice Messages Pending” “No Voice Messages”	If there are voice messages, user can dial “9” and dial pre-configured phone number to retrieve voice message.
99	“RESET”	Enter “9” to reboot the device; or Enter MAC address to restore factory default setting (For details, see section 8.)
	“Invalid Entry”	Automatically return to Main Menu

NOTE:

- *Once the button is pressed, it enters the voice prompt main menu. If the button is pressed again, while it is already in the voice prompt menu, it jumps to “Direct IP Call” option and a dial tone is prompted*
- *“*” shifts down to the next menu option*
- *“#” returns to the main menu*
- *“9” functions as the ENTER key in many cases to confirm an option*
- *All entered digit sequences have known lengths - 2 digits for menu option and 12 digits for IP address. For IP address, add 0 before the digits if the digits are less than 3 (like 192.168.0.26 should be key in like 192168000026, no dot needed while input). Once all of the digits are collected, the input will be processed.*
- *Key entry can not be deleted but the phone may prompt error once it is detected*

5.2 Make Phone Calls

5.2.1 Calling phone or extension numbers

There are currently two methods to make an extension number call:

- a) Dial the numbers directly and wait for 4 (default) seconds.
- b) Dial the numbers directly, and press # (assuming that “use # as dial key is selected in web configuration).

Examples:

- To dial another extension on the same proxy, such as 1008, simply pick up the attached phone, dial 1008 and then press the # or wait for 4 seconds.
- To dial a PSTN number such as 6266667890, you might need to enter in some prefix number followed by the phone number. Please check with your VoIP service provider to get the information. If you phone is assigned with a PSTN-like number such as 6265556789, most likely you just follow the rule to dial 16266667890 as if you were calling from a regular analog phone of North America, then followed by pressing # or wait for 4 seconds.

5.2.2 Direct IP calls

Direct IP calling allows two parties, that is, a HandyTone with an analog phone and another VoIP Device, to talk to each other in an ad hoc fashion without a SIP proxy. This kind of VoIP calls can be made between two parties if:

- Both HT386 and other VoIP Device(i.e., another HandyTone ATA or Budgetone SIP phone or other VoIP unit) have public IP addresses, or
- Both HT386 and other VoIP Device are on the same LAN using private IP addresses, or
- Both HT386 and other VoIP Device can be connected through a router using public or private IP addresses (with necessary port forwarding or DMZ).

To make a direct IP call, first pick up the analog phone or turn on the speakerphone on the analog phone, then access the voice menu prompt by dial “****” or press the button on the HandyTone-286, and dials “47” to access the direct IP call menu. User will hear a voice prompt “Direct IP Calling” and a dial tone. Enter a 12-digit target IP address to make a call. Destination ports can be specified by using “*4” (encoding for “:”) followed by the port number.

Examples:

If the target IP address is 192.168.0.10, the dialing convention is

Voice Prompt with option 47, then 192 168 000 010

followed by pressing the “#” key if it is configured as a send key or wait for more than 5 seconds.

If the target IP address/port is 192.168.1.20:5062, then the dialing convention would be:

Voice Prompt with option 47, then 192168001020*45062 followed by pressing the “#” key if it is configured as a send key or wait for 4 seconds.

NOTE:

- *When doing direct IP call, the “Use Random Port” should set to “NO”.*
- *You can NOT make direct IP calls between FXS1 to FXS2 since they are using same IP.*

5.2.3 Call Hold

While in conversation, pressing the “flash” button on the attached analogue phone (if the phone has that button) will put the remote end on hold. Pressing the “flash” button again will release the previously held party and the bi-directional media will resume. If no “flash” button, then on-off hook quickly (hook flash) will do the same thing but also risk of losing call if the time is not short enough.

5.2.4 Call Waiting

If call waiting feature is enabled, while the user is in a conversation, he will hear a special stutter tone if there is another incoming call. User can press the flash button to put the current call party on hold and switch to the other call. Pressing flash button toggles between two active calls.

5.2.5 Call Transfer

5.2.5.1 Blind Transfer

Assume that call party A and B are in conversation. A wants to *Blind Transfer* B to C:

1. A press FLASH on the analog phone to hear the dial tone.
2. Then A dials *87 then dials C’s number, and then #(or wait for 4 seconds)
3. A can hang up.

NOTE:

- “Enable Call Feature” has to be set to “Yes” in web configuration page.

A can hold on to the phone and await one of the three following behaviors:

- A quick confirmation tone (temporarily using the call waiting indication tone) followed by a dial tone. This indicates the transfer is successful (transferee has received a 200 OK from transfer target). At this point, A can either hang up or make another call.
- A quick busy tone followed by a restored call (on supported platforms only). This means the transferee has received a 4xx response for the INVITE and we will try to recover the call. The busy tone is just to indicate to the transferor that the transfer has failed.
- Busy tone keeps playing. This means we have failed to receive the second NOTIFY from the transferee and decided to time out. Note: this does not indicate the transfer has been successful, nor does it indicate the transfer has failed. When transferee is a client that does not support the second NOTIFY (such as our own earlier firmware), this will be the case. In bad network scenarios, this could also happen, although the transfer may have been completed successfully.

5.2.5.2 Attended Transfer

Assume that call party A and B are in conversation. A wants to *Attend Transfer* B to C:

1. A presses FLASH on the analog phone to get a dial tone
2. A then dial C’s number followed by # (or wait for 4 seconds).
3. If C answers the call, A and C are in conversation. Then A can hang up to complete transfer.
4. If C does not answer the call, A can press “flash” back to talk to B.

NOTE:

- *When Attended Transfer failed and A hang up, the HandyTone- 386 will ring user A back again to remind A that B is still on the call. A can pick up the phone to restore conversation with B.*

5.2.6 3-way Conferencing

5.2.6.1 Star Code Style 3-way Conference

Assuming that call party A and B are in conversation. A wants to bring C in a conference:

1. A presses FLASH (on the analog phone, or Hook Flash for old model phones) to get a dial tone.
2. A dials *23 then C’s number then # (or wait for 4 seconds).
3. If C answers the call, then A press “flash” to bring B, C in the conference.
4. If C does not answer the call, A can press “flash” back to talk to B.

5.2.6.2 Bellcore Style 3-way Conference

Bellcore style 3-way conference is also supported. To do this, user needs to enable “Use Bell-style 3-way Conference” in FXS1 or FXS2 web configuration.

Assuming that call party A and B are in conversation. A wants to bring C in a conference:

1. A presses FLASH (on the analog phone, or Hook Flash for old model phones) to get a dial tone.
2. A dials C’s number then # (or wait for 4 seconds).
3. If C answers the call, then A press “flash” to bring B, C in the conference.
4. If C does not answer the call, A can press “flash” back to talk to B.

5.2.7 PSTN Pass Through

HandyTone-386 supports PSTN pass through on FXS port 1. User can make and receive PSTN calls with attached analog phone in Phone 1 port. Phone 2 port (or FXS port 2) does NOT have this feature.

- To receive PSTN calls, simply make phone off hook when the analog phone rings.
- To make a PSTN call, simply press the PSTN access code (*00 is default, or any number configured in web configuration page) to switch to the PSTN line and get dial tone, then dial the number.

5.3 Call Features

5.3.1 Call Features Table (Star Code)

Following table shows the call features (* code) of HandyTone-386.

Key	Call Features
*23	3 way Conferencing Refer 5.2.6 above for procedure to perform 3 way Calling.
*30	Block CallerID (for all-config change)
*31	Send CallerID (for all-config change)
*67	Block CallerID (per call)
*82	Send CallerID (per call)
*50	Disable Call Waiting (for all-config change)
*51	Enable Call Waiting (for all-config change)
*70	Disable Call Waiting. (Per Call)
*71	Enable Call Waiting (Per Call)
*72	Unconditional Call Forward. To use this feature, dial “*72”, wait for the dial tone. Then dial the forward number ended with #, wait for dial tone, hang up.
*73	Cancel Unconditional Call Forward To cancel “Unconditional Call Forward”, dial “*73” and get the dial tone, then hang up.
*87	Blind Transfer Refer 5.2.5.1 above for procedure to perform Blind Transfer.

*90	Busy Call Forward To use this feature, dial “*90”, wait for the dial tone. Then dial the forward number ended with #, wait for dial tone, hang up.
*91	Cancel Busy Call Forward To cancel “Busy Call Forward”, dial “*91” and get the dial tone, then hang up
*92	Delayed Call Forward To use this feature, dial “*92”, wait for the dial tone. Then dial the forward number ended with #, wait for dial tone, hang up.
*93	Cancel Delayed Call Forward To cancel this Forward, dial “*93” and get the dial tone, then hang up
Flash/Hook	When in conversation, this action will switch to the new incoming call if user heard the call waiting sound. When in conversation and no incoming call heard, this action will switch to a new channel for a new call.

5.3.2 PSTN Pass Through / Life Line

When HandyTone-386 is out of power, the RJ-11 line jack on the HandyTone-386 side will function as a pass through jack. The user will be able to use the analog phone for PSTN calls directly without press the access code.

5.4 FAX Support

HandyTone 386 supports FAX in two modes: T.38 (Fax over IP) and fax pass through. T.38 is the preferred method because it is more reliable and works well in most network conditions. If the service provider supports T.38, please use this method by selecting Fax mode to be T.38 (default). If the service provider does not support T.38, pass-through mode may be used. To send or receive faxes in fax pass through mode, users must select all the Preferred Codecs to be PCMU/PCMA (G.711-u/a).

5.5 LED Light Pattern Indication

Following are the LED light pattern indications.

RED LED always indicates not abnormal status	
DHCP Failed or WAN No Cable	Button flashes every 2 seconds (if DHCP is configured)

HandyTone-486 fails to register	Button flashes every 2 seconds (if SIP server is configured)
Firmware Upgrading	Button flashes every 2 seconds
Device Malfunctions	Red light steady on

GREEN LED mostly indicates normal working status	
Message Waiting Indication	Button flashes every 2 seconds
RINGING	Button flashes at 1/10 second
RINGING INTERVAL	Button flashes every second
In Conversation	Green light steady on

6 Configuration Guide

6.1 Configuring HandyTone-386 LAN IP through Voice Prompt

6.1.1 DHCP Mode

Follow section 5.1 with voice menu option 01 to enable HandyTone-386 to use DHCP.

6.1.2 STATIC IP Mode

Follow section 5.1 with voice menu option 01 to enable HandyTone-386 to use STATIC IP mode, then use option 02, 03, 04 to set up HandyTone-386's IP, Subnet Mask, Gateway respectively.

6.1.3 TFTP Server Address

Follow section 5.1 with voice menu option 06 to configure the IP address of the TFTP server.

6.2 Configuring HandyTone-386 with Web Browser

HandyTone-386 ATA has an embedded Web server that will respond to HTTP GET/POST requests. It also has embedded HTML pages that allow users to configure the HandyTone-386 through a Web browser such as Microsoft's IE, AOL's Netscape or Mozilla Firefox.

6.2.1 Access the Web Configuration Menu

First, get the IP address of the HandyTone-386 through section 5.1 with menu option 02. Then access the HandyTone-386's Web Configuration Menu using the following URI:

<http://Phone-IP-Address>

where the **Phone-IP-Address** is the IP address of the phone.

NOTE:

- To type IP address into browser to get the configuration page, please strip out the announced leading "0" as the browser will parse in octet. e.g.: if the IP address reported: 192.168.001.014, please type in: 192.168.1.14.

6.2.2 End User Configuration

Once this HTTP request is entered and sent from a Web browser, the HandyTone-386 will respond with the following login screen:

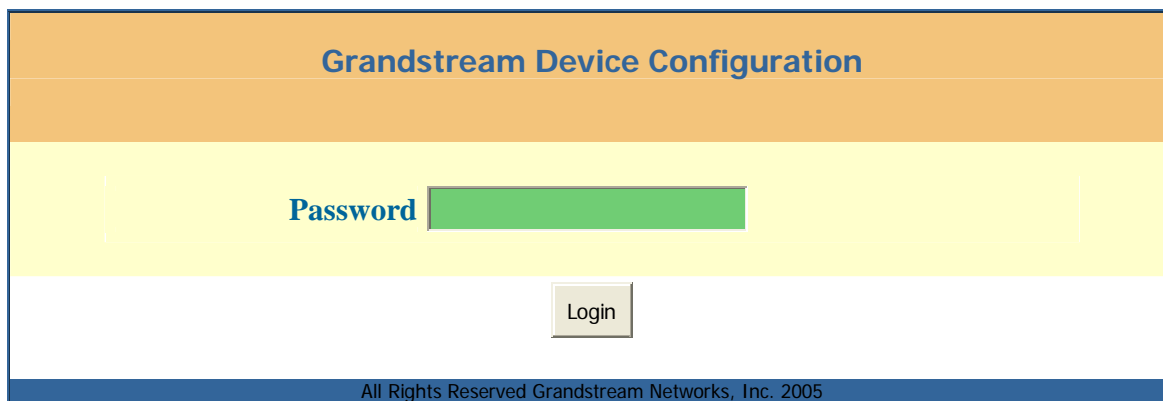

Grandstream Device Configuration

Password

Login

All Rights Reserved Grandstream Networks, Inc. 2005

The password is case sensitive with maximum length of 25 characters. The factory default password for End User and administrator is “123” and “admin” respectively. Only administrator can get access to the “ADVANCED SETTING” configuration page.

NOTE:

- *If you **CAN NOT** log into the configuration page by using default password, please check with the VoIP service provider. Most likely the VoIP service provider has provisioned the device and configured for you therefore the password has already been changed.*

After a correct password is entered in the login screen, the embedded Web server inside the HandyTone-386 will respond with the Configuration pages which are explained in details below.

- **Status Page:**

Grandstream Device Configuration						
	STATUS	BASIC SETTINGS	ADVANCED SETTINGS	FXS PORT1	FXS PORT2	
MAC Address:	00.0B.82.00.00.00					
IP Address:	192.168.1.109					
Product Model:	HT386					
Software Version:	Program-- 1.0.3.44 Bootloader-- 1.0.8.11 HTML-- 1.0.3.44 VOC-- 1.0.0.10					
System Up Time:	0 day(s) 0 hour(s) 2 minute(s)					
Registered:	Yes					
PPPoE Link Up:	disabled					
NAT:	detected NAT type is full cone					
All Rights Reserved Grandstream Networks, Inc. 2005						

MAC Address	The device ID, in HEX format. This is very important ID for ISP troubleshooting.
IP Address	This field shows IP address of the HT386.
Product Model	This field contains the product model info, such as HT386.
Software Version	Program: This is the main software release. <i>This number is always used for firmware upgrade.</i> Current release is 1.0.3.44 Bootloader: current version is 1.0.8.11. HTML: current version 1.0.3.44. VOC: current version is 1.0.0.10
System Uptime	This shows system up time since last reboot.
Registered	Whether the unit is registered to service provider's server.
PPPoE Link Up	This shows whether the PPPoE is up if connected to DSL modem
NAT	This shows what kind NAT the HT386 is connected to. It is based on STUN protocol. If the detected NAT is symmetric NAT, STUN will not work and Outbound Proxy needed to make HT386 functioning correctly.

- **Basic Settings Page:**

Grandstream Device Configuration																											
STATUS	BASIC SETTINGS																										
ADVANCED SETTINGS	FXS PORT1																										
FXS PORT2																											
End User Password:	<input type="text" value=""/> (purposely not displayed for security protection)																										
Web Port:	<input type="text" value="80"/> (default for HTTP is 80)																										
IP Address:	<input checked="" type="checkbox"/> dynamically assigned via DHCP (default) or PPPoE (will attempt PPPoE if DHCP fails and following is non-blank) <table border="1" style="width: 100%; border-collapse: collapse;"> <tr> <td>DHCP hostname:</td> <td><input type="text" value=""/></td> </tr> <tr> <td>DHCP domain:</td> <td><input type="text" value=""/></td> </tr> <tr> <td>DHCP vendor class ID:</td> <td><input type="text" value=""/></td> </tr> <tr> <td>PPPoE account ID:</td> <td><input type="text" value=""/></td> </tr> <tr> <td>PPPoE password:</td> <td><input type="text" value=""/></td> </tr> <tr> <td>PPPoE Service Name:</td> <td><input type="text" value=""/></td> </tr> <tr> <td>Preferred DNS server:</td> <td><input type="text" value="0.0.0.0"/></td> </tr> <tr> <td><input checked="" type="checkbox"/> statically configured as:</td> <td></td> </tr> <tr> <td>IP Address:</td> <td><input type="text" value="192.168.0.160"/></td> </tr> <tr> <td>Subnet Mask:</td> <td><input type="text" value="0.0.0.0"/></td> </tr> <tr> <td>Default Router:</td> <td><input type="text" value="0.0.0.0"/></td> </tr> <tr> <td>DNS Server 1:</td> <td><input type="text" value="0.0.0.0"/></td> </tr> <tr> <td>DNS Server 2:</td> <td><input type="text" value="0.0.0.0"/></td> </tr> </table>	DHCP hostname:	<input type="text" value=""/>	DHCP domain:	<input type="text" value=""/>	DHCP vendor class ID:	<input type="text" value=""/>	PPPoE account ID:	<input type="text" value=""/>	PPPoE password:	<input type="text" value=""/>	PPPoE Service Name:	<input type="text" value=""/>	Preferred DNS server:	<input type="text" value="0.0.0.0"/>	<input checked="" type="checkbox"/> statically configured as:		IP Address:	<input type="text" value="192.168.0.160"/>	Subnet Mask:	<input type="text" value="0.0.0.0"/>	Default Router:	<input type="text" value="0.0.0.0"/>	DNS Server 1:	<input type="text" value="0.0.0.0"/>	DNS Server 2:	<input type="text" value="0.0.0.0"/>
DHCP hostname:	<input type="text" value=""/>																										
DHCP domain:	<input type="text" value=""/>																										
DHCP vendor class ID:	<input type="text" value=""/>																										
PPPoE account ID:	<input type="text" value=""/>																										
PPPoE password:	<input type="text" value=""/>																										
PPPoE Service Name:	<input type="text" value=""/>																										
Preferred DNS server:	<input type="text" value="0.0.0.0"/>																										
<input checked="" type="checkbox"/> statically configured as:																											
IP Address:	<input type="text" value="192.168.0.160"/>																										
Subnet Mask:	<input type="text" value="0.0.0.0"/>																										
Default Router:	<input type="text" value="0.0.0.0"/>																										
DNS Server 1:	<input type="text" value="0.0.0.0"/>																										
DNS Server 2:	<input type="text" value="0.0.0.0"/>																										
Time Zone:	<input type="text" value="GMT-5:00 (US Eastern Time, New York)"/> ▼																										
Daylight Savings Time:	<input checked="" type="checkbox"/> No <input checked="" type="checkbox"/> Yes																										
	Optional Rule: <input type="text" value="4,1,7,2,0;10,-1,7,2,0;60"/>																										
PSTN access code:	<input type="text" value=""/> (key pattern to use the PSTN line, default is "*00")																										
<input type="button" value="Update"/>																											

End User Password	This contains the password for end user to access the Web Configuration Menu. User can put new password here. This field is case sensitive with maximum of 25 characters
Web Port	This is the device's internal HTTP server port. Default is 80.
IP Address	<p>- If DHCP mode is enabled, then all the field values for the Static IP mode are not used (even though they are still saved in the Flash memory.) The HT386 will acquire its IP address from DHCP in the network.</p> <p>PPPoE settings is usually for DSL/ADSL modem users. The HandyTone will attempt to establish a PPPoE session if PPPoE account is set.</p> <p>- If Static IP mode is selected, the IP address, Subnet Mask, Default Router IP address, DNS Server 1 (mandatory), DNS Server 2 (optional) fields need to be configured.</p>
DHCP hostname	This option specifies the name of the client. This field is optional but may be required by some Internet Service Providers. Default is blank.
DHCP domain	This option specifies the domain name that client should use when resolving hostnames via the Domain Name System. Default is blank.
DHCP vendor class ID	This option is used by clients and servers to exchange vendor-specific information. Default is blank.
Time Zone	This parameter controls how the displayed date/time will be adjusted according to the specified time zone.

Daylight Savings Time	<p>This parameter controls whether the displayed time will be daylight savings time or not. If set to “Yes” and the Optional Rule is empty, then the displayed time will be 1 hour ahead of normal time.</p> <p>The “Automatic Daylight Saving Time Rule” shall have the following syntax: start-time;end-time;saving Both start-time and end-time have the same syntax: month,day,weekday,hour,minute month: 1,2,3,...,12 (for Jan, Feb, ..., Dec) day: [+ -]1,2,3,...,31 weekday: 1, 2, 3, ..., 7 (for Mon, Tue, ..., Sun), or 0 which means the daylight saving rule is not based on week days but based on the day of the month. hour: hour (0-23), minute: minute (0-59)</p> <p>If “weekday” is 0, it means the date to start or end daylight saving is at exactly the given date. In that case, the “day” value must not be negative. If “weekday” is not zero and “day” is positive, then the daylight saving starts on the first “day”th iteration of the weekday (1st Sunday, 3rd Tuesday etc). If “weekday” is not zero and “day” is negative, then the daylight saving starts on the last “day”th iteration of the weekday (last Sunday, 3rd last Tuesday etc).</p> <p>The saving is in the unit of minutes. The saving time may also be preceded by a negative (-) sign if subtraction is desired instead of addition.</p> <p>The default value for “Automatic Daylight Saving Time Rule” shall be set to “04,01,7,02,00;10,-1,7,02,00;60” which is the rule for US.</p> <p>Examples US/Canada where daylight saving time is applicable: 04,01,7,02,00;10,-1,7,02,00;60 This means the daylight saving time starts from the first Sunday of April at 2AM and ends the last Sunday of October at 2AM. The saving is 60 minutes (1hour).</p>
PSTN Access Code	<p>Default is “*00”, user can change it. By pressing the code user can switch the phone to PSTN line connected to the Line port of ATA and make PSTN outgoing calls. This is called PSTN Pass Through.</p>

6.2.3 Advanced Configuration and FXS ports Parameters

To login to the Advanced Setting and FXS port configuration pages, administrator password is required. The default administrator password is “admin”. User can change the administrator password here. The password is case sensitive and the maximum length is 25 characters.

- **Advanced Settings Page:**

Grandstream Device Configuration				
STATUS	BASIC SETTINGS	ADVANCED SETTINGS	FXS PORT1	FXS PORT2
Admin Password:	[REDACTED] (purposely not displayed for security protection)			
Home NPA:	[REDACTED]			
<i>Layer 3 QoS:</i>	[REDACTED] (Diff-Serv or Precedence value)			
<i>Layer 2 QoS:</i>	802.1Q/VLAN Tag [REDACTED]		802.1p priority value [REDACTED] (0-7)	
<i>STUN server is :</i>	[REDACTED] (URI or IP:port)			
<i>keep-alive interval:</i>	[REDACTED] (in seconds, default 20 seconds)			
<i>Use NAT IP:</i>	[REDACTED] (used in SIP/SDP message if specified)			
<i>Firmware Upgrade and Provisioning:</i>	Upgrade Via		<input checked="" type="checkbox"/> TFTP	<input checked="" type="checkbox"/> HTTP
	Firmware Server Path:		[REDACTED] fm.grandstream.com/gs	
	Config Server Path:		[REDACTED] fm.grandstream.com/gs	
	Firmware File Prefix:		[REDACTED]	Firmware File Postfix:
	Config File Prefix:		[REDACTED]	Config File Postfix:
	Automatic Upgrade:			
	<input checked="" type="checkbox"/> No		<input checked="" type="checkbox"/> Yes, check for upgrade every [REDACTED] 10080 minutes (default 7 days)	
	<input checked="" type="checkbox"/> Always Check for New Firmware		<input checked="" type="checkbox"/> Check New Firmware only when F/W pre/suffix changes	

<i>Firmware Key:</i>	<input type="text" value=""/>	(in Hexadecimal Representation)
<i>Onhook Threshold:</i>	<input type="text" value="800 ms"/>	
<i>FXS Impedance:</i>	<input type="text" value="600 Ohm (North America)"/>	
<i>Caller ID Scheme:</i>	<input type="text" value="Bellcore (North America)"/>	
<i>Onhook Voltage:</i>	<input type="text" value="36V"/>	
<i>Polarity Reversal:</i>	<input type="checkbox"/> No <input type="checkbox"/> Yes	(reverse polarity upon call establishment and termination)
<i>NTP Server:</i>	<input type="text" value="time.nist.gov"/>	(URI or IP address)
<i>Syslog Server:</i>	<input type="text" value=""/>	
<i>Syslog Level:</i>	<input type="text" value="NONE"/>	
<input type="button" value="Update"/>		
All Rights Reserved Grandstream Networks, Inc. 2005		

Admin Password	Administrator password. Only administrator can configure the “Advanced Settings” page. Password field is purposely blanked for security reason after clicking update and saved. The maximum password length is 25 characters.
Home NPA	Local area code for North American Dial Plan.
Layer 3 QoS	This field defines the layer 3 QoS parameter which can be the value used for IP Precedence or Diff-Serv or MPLS. Default value is 48.
Layer 2 QoS	Layer 2 QoS settings. Default setting is blank. Other VLAN supported equipments required if configured these settings.
No Key Entry timeout	Default is 4 seconds. User can short or extend that depends on digits dialed
STUN Server	IP address or Domain name of the STUN server.
Keep-alive interval	Default is 20 seconds. The interval of sending dummy UDP packet to keep NAT “pin hole” open.
Use NAT IP	NAT IP address used in SIP/SDP message. Default is blank.
Firmware Upgrade and Provisioning	Default method is HTTP. Firmware upgrade may take up to 10 minutes depending on network environment. Do not interrupt the firmware upgrading process.

Firmware Server Path	IP address or domain name of firmware server.
Config Server Path	IP address or domain name of configuration server.
Firmware File Prefix	Default is blank. If configured, HandyTone-386 will request the firmware file with the prefix. This setting is useful for ITSPs. End user should keep it blank.
Firmware File Postfix	Default is blank. End user should keep it blank.
Config File Prefix	Default is blank. End user should keep it blank.
Config File Postfix	Default is blank. End user should keep it blank.
Automatic Upgrade	Default is “Yes”.
Firmware Key	For firmware encryption. It should be 32 digit in Hexadecimal Representation. End user should keep it blank.
Caller ID Scheme	<ul style="list-style-type: none"> • Bellcore (North America) • CID (Canada) • DTMF (Brazil) • DTMF (Sweden) • DTMF (Denmark) • ETSI-DTMF (Finland, Sweden) • ETSI-FSK (France, Germany, Norway, Taiwan, UK-CCA)
Onhook Voltage	Select the onhook voltage to suit different area or PBX.
Polarity Reversal	Default is No. If set to Yes, polarity will be reversed upon call establishment and termination.
NTP server	URI or IP address of the NTP (Network Time Protocol) server, which the HT386 will use to synchronize the date/time.
Syslog Server	The IP address or URL of syslog server, especially useful for ITSP (Internet Telephone Service Provider)

Syslog Level	<p>Select the ATA to report the log level. Default is NONE. The level is either one of DEBUG, INFO, WARNING or ERROR. Syslog messages are sent based on the following events:</p> <ul style="list-style-type: none"> • product model/version on boot up (INFO level) • NAT related info (INFO level) • sent or received SIP message (DEBUG level) • SIP message summary (INFO level) • inbound and outbound calls (INFO level) • registration status change (INFO level) • negotiated codec (INFO level) • Ethernet link up (INFO level) • SLIC chip exception (WARNING and ERROR levels) • memory exception (ERROR level) <p>The Syslog uses USER facility. In addition to standard Syslog payload, it contains the following components:</p> <p>GS_LOG: [device MAC address][error code] error message</p> <p>Here is an example: May 19 02:40:38 192.168.1.14 GS_LOG: [00:0b:82:00:a1:be][000] Ethernet link is up</p>
---------------------	---

• **FXS Port 1 Page:**

Grandstream Device Configuration					
	STATUS	BASIC SETTINGS	ADVANCED SETTINGS	FXS PORT1	FXS PORT2
SIP Server:		(e.g., sip.mycompany.com, or IP address)			
Outbound Proxy:		(e.g., proxy.myprovider.com, or IP address, if any)			
SIP User ID:		(the user part of an SIP address)			
Authenticate ID:		(can be identical to or different from SIP User ID)			
Authenticate Password:		(purposely not displayed for security protection)			
Name:		(optional, e.g., John Doe)			
Use DNS SRV:	<input type="checkbox"/> No	<input checked="" type="checkbox"/> Yes			

<i>User ID is phone number:</i>	<input checked="" type="checkbox"/> No <input checked="" type="checkbox"/> Yes
<i>SIP Registration:</i>	<input checked="" type="checkbox"/> No <input checked="" type="checkbox"/> Yes
<i>Unregister On Reboot:</i>	<input checked="" type="checkbox"/> No <input checked="" type="checkbox"/> Yes
<i>Register Expiration:</i>	<input type="text" value="60"/> (in minutes. default 1 hour, max 45 days)
<i>local SIP port:</i>	<input type="text" value="5060"/> (default 5060)
<i>local RTP port:</i>	<input type="text" value="5004"/> (1024-65535, default 5004)
<i>Use random port:</i>	<input checked="" type="checkbox"/> No <input checked="" type="checkbox"/> Yes
<i>DTMF Payload Type:</i>	<input type="text" value="101"/>
<i>Send DTMF:</i>	<input type="checkbox"/> in-audio <input checked="" type="checkbox"/> via RTP (RFC2833) <input type="checkbox"/> via SIP INFO
<i>Send Flash Event:</i>	<input checked="" type="checkbox"/> No <input checked="" type="checkbox"/> Yes (Flash will be sent as a DTMF event if set to Yes)
<i>Enable Call Features:</i>	<input checked="" type="checkbox"/> No <input checked="" type="checkbox"/> Yes (if Yes, Call Forwarding & Call-Waiting-Disable are supported locally)
<i>Use Bell-style 3-way Conference:</i>	<input checked="" type="checkbox"/> No <input checked="" type="checkbox"/> Yes (if Yes, *23 will be disabled)
<i>Offhook Auto-Dial:</i>	<input type="text" value=""/> (User ID/extension to dial automatically when offhook)
<i>Proxy-Require:</i>	<input type="text" value=""/>
<i>Disable Call-Waiting:</i>	<input checked="" type="checkbox"/> No <input checked="" type="checkbox"/> Yes
<i>NAT Traversal (STUN):</i>	<input checked="" type="checkbox"/> No <input checked="" type="checkbox"/> Yes
<i>No Key Entry Timeout:</i>	<input type="text" value="4"/> (in seconds, default is 4 seconds)
<i>Preferred Vocoder: (in listed order)</i>	choice 1: <input type="text" value="PCMU"/> choice 2: <input type="text" value="PCMA"/> choice 3: <input type="text" value="G.729A/B"/> choice 4: <input type="text" value="G.723.1"/> choice 5: <input type="text" value="G.726-32"/> choice 6: <input type="text" value="iLBC"/>
<i>Voice Frames per</i>	<input type="text" value="2"/> (up to 10/20/32/64 for G711/G726/G723/other codecs respectively)

<i>TX:</i>																																														
<i>G723 rate:</i>	<input checked="" type="checkbox"/> 6.3kbps encoding rate <input checked="" type="checkbox"/> 5.3kbps encoding rate																																													
<i>iLBC frame size:</i>	<input checked="" type="checkbox"/> 20ms <input checked="" type="checkbox"/> 30ms																																													
<i>iLBC payload type:</i>	<input type="text" value="97"/> (between 96 and 127, default is 97)																																													
<i>Silence Suppression:</i>	<input checked="" type="checkbox"/> No <input checked="" type="checkbox"/> Yes																																													
<i>Fax Mode:</i>	<input checked="" type="checkbox"/> T.38 (Auto Detect) <input checked="" type="checkbox"/> Pass-Through																																													
<i>Early Dial:</i>	<input checked="" type="checkbox"/> No <input checked="" type="checkbox"/> Yes (use "Yes" only if proxy supports 484 response)																																													
<i>Dial Plan Prefix:</i>	<input type="text"/> (this prefix string is added to each dialed number)																																													
<i>Use # as Dial Key:</i>	<input checked="" type="checkbox"/> No <input checked="" type="checkbox"/> Yes (if set to Yes, "#" will function as the "(Re-)Dial" key)																																													
<i>SUBSCRIBE for MWI:</i>	<input checked="" type="checkbox"/> No, do not send SUBSCRIBE for Message Waiting Indication <input checked="" type="checkbox"/> Yes, send periodical SUBSCRIBE for Message Waiting Indication																																													
<i>Send Anonymous:</i>	<input checked="" type="checkbox"/> No <input checked="" type="checkbox"/> Yes (caller ID will be blocked if set to Yes)																																													
<i>Lock keypad update:</i>	<input checked="" type="checkbox"/> No <input checked="" type="checkbox"/> Yes (configuration update via keypad is disabled if set to Yes)																																													
<i>Special Feature:</i>	<input type="text" value="Standard"/> ▼																																													
<i>Distinct Ring Tones:</i>	<table border="1"> <thead> <tr> <th>Frequency1 (Hz)</th> <th>Frequency2 (Hz)</th> <th>ON(x10ms) (C1;C2;C3)</th> <th>OFF(x10ms) (C1;C2;C3)</th> <th></th> </tr> </thead> <tbody> <tr> <td><input type="text" value="350"/></td> <td><input type="text" value="440"/></td> <td><input type="text" value="0"/></td> <td><input type="text" value="0"/></td> <td>Dial Tone</td> </tr> <tr> <td><input type="text" value="350"/></td> <td><input type="text" value="440"/></td> <td><input type="text" value="10"/></td> <td><input type="text" value="10"/></td> <td>Recall Dial Tone</td> </tr> <tr> <td><input type="text" value="350"/></td> <td><input type="text" value="440"/></td> <td><input type="text" value="10"/></td> <td><input type="text" value="10"/></td> <td>Message Waiting</td> </tr> <tr> <td><input type="text" value="350"/></td> <td><input type="text" value="440"/></td> <td><input type="text" value="10"/></td> <td><input type="text" value="10"/></td> <td>Confirmation</td> </tr> <tr> <td><input type="text" value="440"/></td> <td><input type="text" value="480"/></td> <td><input type="text" value="200"/></td> <td><input type="text" value="400"/></td> <td>Audible Ringing</td> </tr> <tr> <td><input type="text" value="480"/></td> <td><input type="text" value="620"/></td> <td><input type="text" value="50"/></td> <td><input type="text" value="50"/></td> <td>Busy Tone</td> </tr> <tr> <td><input type="text" value="480"/></td> <td><input type="text" value="620"/></td> <td><input type="text" value="25"/></td> <td><input type="text" value="25"/></td> <td>Reorder Tone</td> </tr> <tr> <td><input type="text" value="1400"/></td> <td><input type="text" value="2600"/></td> <td><input type="text" value="10"/></td> <td><input type="text" value="10"/></td> <td>Receiver offhook</td> </tr> </tbody> </table>	Frequency1 (Hz)	Frequency2 (Hz)	ON(x10ms) (C1;C2;C3)	OFF(x10ms) (C1;C2;C3)		<input type="text" value="350"/>	<input type="text" value="440"/>	<input type="text" value="0"/>	<input type="text" value="0"/>	Dial Tone	<input type="text" value="350"/>	<input type="text" value="440"/>	<input type="text" value="10"/>	<input type="text" value="10"/>	Recall Dial Tone	<input type="text" value="350"/>	<input type="text" value="440"/>	<input type="text" value="10"/>	<input type="text" value="10"/>	Message Waiting	<input type="text" value="350"/>	<input type="text" value="440"/>	<input type="text" value="10"/>	<input type="text" value="10"/>	Confirmation	<input type="text" value="440"/>	<input type="text" value="480"/>	<input type="text" value="200"/>	<input type="text" value="400"/>	Audible Ringing	<input type="text" value="480"/>	<input type="text" value="620"/>	<input type="text" value="50"/>	<input type="text" value="50"/>	Busy Tone	<input type="text" value="480"/>	<input type="text" value="620"/>	<input type="text" value="25"/>	<input type="text" value="25"/>	Reorder Tone	<input type="text" value="1400"/>	<input type="text" value="2600"/>	<input type="text" value="10"/>	<input type="text" value="10"/>	Receiver offhook
	Frequency1 (Hz)	Frequency2 (Hz)	ON(x10ms) (C1;C2;C3)	OFF(x10ms) (C1;C2;C3)																																										
	<input type="text" value="350"/>	<input type="text" value="440"/>	<input type="text" value="0"/>	<input type="text" value="0"/>	Dial Tone																																									
	<input type="text" value="350"/>	<input type="text" value="440"/>	<input type="text" value="10"/>	<input type="text" value="10"/>	Recall Dial Tone																																									
	<input type="text" value="350"/>	<input type="text" value="440"/>	<input type="text" value="10"/>	<input type="text" value="10"/>	Message Waiting																																									
	<input type="text" value="350"/>	<input type="text" value="440"/>	<input type="text" value="10"/>	<input type="text" value="10"/>	Confirmation																																									
	<input type="text" value="440"/>	<input type="text" value="480"/>	<input type="text" value="200"/>	<input type="text" value="400"/>	Audible Ringing																																									
	<input type="text" value="480"/>	<input type="text" value="620"/>	<input type="text" value="50"/>	<input type="text" value="50"/>	Busy Tone																																									
<input type="text" value="480"/>	<input type="text" value="620"/>	<input type="text" value="25"/>	<input type="text" value="25"/>	Reorder Tone																																										
<input type="text" value="1400"/>	<input type="text" value="2600"/>	<input type="text" value="10"/>	<input type="text" value="10"/>	Receiver offhook																																										
<i>Volume Amplification:</i>	<i>TX</i> <input type="text" value="0dB default"/> ▼ <i>RX</i> <input type="text" value="0dB default"/> ▼																																													
<input type="button" value="Update"/>																																														
All Rights Reserved Grandstream Networks, Inc. 2005																																														

- **FXS Port 2 Page:**

Grandstream Device Configuration						
	STATUS	BASIC SETTINGS	ADVANCED SETTINGS	FXS PORT1	FXS PORT2	
SIP Server:		sip.sipserver2.com	(e.g., sip.mycompany.com, or IP address)			
Outbound Proxy:			(e.g., proxy.myprovider.com, or IP address, if any)			
SIP User ID:		200	(the user part of an SIP address)			
Authenticate ID:		200	(can be identical to or different from SIP User ID)			
Authenticate Password:			(purposely not displayed for security protection)			
Name:		David	(optional, e.g., John Doe)			
Use DNS SRV:	<input checked="" type="checkbox"/>	No	<input checked="" type="checkbox"/>	Yes		
User ID is phone number:	<input checked="" type="checkbox"/>	No	<input checked="" type="checkbox"/>	Yes		
SIP Registration:	<input checked="" type="checkbox"/>	No	<input checked="" type="checkbox"/>	Yes		
Unregister On Reboot:	<input checked="" type="checkbox"/>	No	<input checked="" type="checkbox"/>	Yes		
Register Expiration:		60	(in minutes. default 1 hour, max 45 days)			
local SIP port:		5062	(default 5062)			
local RTP port:		5008	(1024-65535, default 5008)			
Use random port:	<input checked="" type="checkbox"/>	No	<input checked="" type="checkbox"/>	Yes		
DTMF Payload Type:		101				
Send DTMF:	<input type="checkbox"/>	in-audio	<input checked="" type="checkbox"/>	via RTP(RFC2833)	<input type="checkbox"/>	via SIP INFO
Send Flash Event:	<input checked="" type="checkbox"/>	No	<input checked="" type="checkbox"/>	Yes	(Flash will be sent as a DTMF event if set to Yes)	
Enable Call Features:	<input checked="" type="checkbox"/>	No	<input checked="" type="checkbox"/>	Yes	(if Yes, Call Forwarding & Call-Waiting-Disable are supported locally)	
Use Bell-style 3-way Conference:	<input checked="" type="checkbox"/>	No	<input checked="" type="checkbox"/>	Yes	(if Yes, *23 will be disabled)	

<i>Offhook Auto-Dial:</i>	<input type="text"/> (User ID/extension to dial automatically when offhook)			
<i>Proxy-Require:</i>	<input type="text"/>			
<i>Disable Call-Waiting:</i>	<input checked="" type="checkbox"/> No	<input checked="" type="checkbox"/> Yes		
<i>NAT Traversal (STUN):</i>	<input checked="" type="checkbox"/> No	<input checked="" type="checkbox"/> Yes		
<i>No Key Entry Timeout:</i>	<input type="text" value="4"/>	(in seconds, default is 4 seconds)		
<i>Preferred Vocoder: (in listed order)</i>	choice 1:	<input type="text" value="PCMU"/>		
	choice 2:	<input type="text" value="PCMA"/>		
	choice 3:	<input type="text" value="G.729A/B"/>		
	choice 4:	<input type="text" value="G.723.1"/>		
	choice 5:	<input type="text" value="G.726-32"/>		
	choice 6:	<input type="text" value="iLBC"/>		
<i>Voice Frames per TX:</i>	<input type="text" value="2"/>	(up to 10/20/32/64 for G711/G726/G723/other codecs respectively)		
<i>G723 rate:</i>	<input checked="" type="checkbox"/> 6.3kbps encoding rate	<input checked="" type="checkbox"/> 5.3kbps encoding rate		
<i>iLBC frame size:</i>	<input checked="" type="checkbox"/> 20ms	<input checked="" type="checkbox"/> 30ms		
<i>iLBC payload type:</i>	<input type="text" value="97"/>	(between 96 and 127, default is 97)		
<i>Silence Suppression:</i>	<input checked="" type="checkbox"/> No	<input checked="" type="checkbox"/> Yes		
<i>Fax Mode:</i>	<input checked="" type="checkbox"/> T.38 (Auto Detect)	<input checked="" type="checkbox"/> Pass-Through		
<i>Early Dial:</i>	<input checked="" type="checkbox"/> No	<input checked="" type="checkbox"/> Yes	(use "Yes" only if proxy supports 484 response)	
<i>Dial Plan Prefix:</i>	<input type="text"/> (this prefix string is added to each dialed number)			
<i>Use # as Dial Key:</i>	<input checked="" type="checkbox"/> No	<input checked="" type="checkbox"/> Yes	(if set to Yes, "#" will function as the "(Re-)Dial" key)	
<i>SUBSCRIBE for MWI:</i>	<input checked="" type="checkbox"/> No, do not send SUBSCRIBE for Message Waiting Indication			
	<input checked="" type="checkbox"/> Yes, send periodical SUBSCRIBE for Message Waiting Indication			
<i>Send Anonymous:</i>	<input checked="" type="checkbox"/> No	<input checked="" type="checkbox"/> Yes	(caller ID will be blocked if set to Yes)	
<i>Special Feature:</i>	<input type="text" value="Standard"/>			
<i>Distinct Ring Tones:</i>	Frequency1 (Hz)	Frequency2 (Hz)	ON(x10ms) (C1;C2;C3)	OFF(x10ms) (C1;C2;C3)

	350	440	0	0	Dial Tone
	350	440	10	10	Recall Dial Tone
	350	440	10	10	Message Waiting
	350	440	10	10	Confirmation
	440	480	200	400	Audible Ringing
	480	620	50	50	Busy Tone
	480	620	25	25	Reorder Tone
	1400	2600	10	10	Receiver offhook
<i>Volume Amplification:</i>	TX <input type="text" value="0dB default"/>		RX <input type="text" value="0dB default"/>		
<input type="button" value="Update"/>					
All Rights Reserved Grandstream Networks, Inc. 2005					

The explanations provided apply to both of the FXS port configuration parameters:

SIP Server	IP address or Domain name provided by VoIP service provider
Outbound Proxy	IP address or Domain name of Outbound Proxy, or Media Gateway, or Session Border Controller. Used by ATA for firewall or NAT penetration in different network environment. If symmetric NAT is detected, STUN will not work and ONLY Outbound Proxy will work.
SIP User ID	User account information, provided by VoIP service provider (ITSP), usually has the form of digit similar to phone number or actually a phone number
Authenticate ID	ID used for authentication, usually same as SIP user ID, but could be different and decided by ITSP.
Authentication Password	Password for ATA to register to (SIP) servers of ITSP. Purposely blank out once saved for security. Maximum length is 25.
Name	User name, not user ID, for information only.
Use DNS SRV:	Default is No. If set to Yes the client will use DNS SRV to lookup for the server
User ID is Phone Number	If the HandyTone. If set to yes, a “user=phone” parameter will be attached to the “From” header in SIP request
SIP Registration	This parameter controls whether the HT386 needs to send REGISTER messages to the proxy server. The default setting is “Yes”.

Unregister On Reboot	Default is No. If set to Yes, the device will first send registration request to indicate SIP registra to remove previous bindings.
Register Expiration	This parameter allows the user to specify the time frequency (in minutes) the HT386 will refresh its registration with the specified registrar. The default interval is 60 minutes (or 1 hour). The maximum interval is 65535 minutes (about 45 days).
Local SIP port	This parameter defines the local SIP port the HT386 will listen and transmit. The default value is for FXS1 is 5060, FXS2 is 5062
Local RTP port	This parameter defines the local RTP-RTCP port pair the HT386 will listen and transmit. It is the base RTP port for channel 0. When configured, channel 0 will use this port_value for RTP and the port_value+1 for its RTCP; channel 1 will use port_value+2 for RTP and port_value+3 for its RTCP. The default value for FXS1 is 5004, FXS2 is 5008.
Use Random Port	Default No. If set to Yes, the device will pick randomly-generated SIP and RTP ports. This is usually necessary when multiple SIP devices are behind the same NAT. For Direct IP to IP call, this should be set to No.
DTMF Payload Type	This parameter sets the payload type for DTMF using RFC2833
Send DTMF	This parameter specifies the mechanism to transmit DTMF digit. There are 3 modes supported: in audio which means DTMF is combined in audio signal (not very reliable with low-bit-rate codec), via RTP (RFC2833), or via SIP INFO.
Send Flash Event	Default is NO. If set to yes, flash will be sent as DTMF event.
Enable Call Features	Default is Yes. Advance call features and feature codes functions are supported locally
Use Bell-style 3-way Conference	If this parameter is set to “Yes”, user will be able to make Bellcore style 3-way conference. *23 will be disabled.
Offhook Auto-Dial	This parameter allows a user to configure a User ID or extension number to be automatically dialed upon offhook. Please note that only the user part of a SIP address needs to be entered here. The HT386 will automatically append the “@” and the host portion of the corresponding SIP address. NOTE: Please write down the IP address of the ATA if you use this feature as it will disable the IVR and the only way to access the HT386 is via web configuration page.
Proxy-Require	SIP Extension to notify SIP server that the unit is behind the NAT/Firewall.
Disable Call Waiting	Default is No. User can use * code to use this feature per call basis.

NAT Traversal	This parameter defines whether the HT386 NAT traversal mechanism will be activated or not. If activated (by choosing “Yes”) and a STUN server is also specified, then the HT386 will behave according to the STUN client specification. Under this mode, the embedded STUN client inside the HT386 will attempt to detect if and what type of firewall/NAT it is sitting behind through communication with the specified STUN server. If the detected NAT is a Full Cone, Restricted Cone, or a Port-Restricted Cone, the HT386 will attempt to use its mapped public IP address and port in all of its SIP and SDP messages. If the NAT Traversal field is set to “Yes” with no specified STUN server, the HT386 will periodically (every 20 seconds or so) send a blank UDP packet (with no payload data) to the SIP server to keep the “hole” on the NAT open.
Preferred Vocoder	The HT386 supports 6 different codec types including : G.711 A/Ulaw , G.723.1, G.726, G.729A/B, iLBC. A user can configure codecs in a preference list that will be included with the same preference order in SDP message.
Voice Frames per TX	This field contains the number of voice frames to be transmitted in a single packet. When setting this value, the user should be aware of the requested packet time (used in SDP message) as a result of configuring this parameter. This parameter is associated with the first codec in the above codec Preference List or the actual used payload type negotiated between the 2 conversation parties at run time. e.g., if the first codec is configured as G723 and the “Voice Frames per TX” is set to be 2, then the “ptime” value in the SDP message of an INVITE request will be 60ms because each G723 voice frame contains 30ms of audio. Similarly, if this field is set to be 2 and if the first codec chosen is G729 or G711 or G726, then the “ptime” value in the SDP message of an INVITE request will be 20ms. If the configured voice frames per TX exceeds the maximum allowed value, the HT386 will use and save the maximum allowed value for the corresponding first codec choice. The maximum value for PCM is 10(x10ms) frames; for G726, it is 20 (x10ms) frames; for G723, it is 32 (x30ms) frames; for G729/G728, 64 (x10ms) and 64 (x2.5ms) frames respectively. Please be careful when message those parameters.
G723 Rate:	Encoding rate for G723 codec. By default, 6.3kbps rate is set.
iLBC frame size:	iLBC packet frame size. Default is 20ms. For Asterisk PBX, 30ms might need to be set.
iLBC payload type:	Payload type for iLBC. Default value is 97. The valid range is between 96 and 127.

Silence Suppression	This controls the silence suppression/VAD feature of G723 and G729. If set to “Yes”, when a silence is detected, small quantity of VAD packets (instead of audio packets) will be sent during the period of no talking. If set to “No”, this feature is disabled.
Fax Mode	T.38 (Auto Detect) FoIP by default, or Pass-Through (must use codec PCMU/PCMA)
Early Dial	Default is No. Use only if proxy supports 484 response
Dial Plan Prefix	Sets the prefix added to each dialed number
Use # as Dial/Send Key	This parameter allows the user to configure the “#” key to be used as the “Send”(or “Dial”) key. Once set to “Yes”, pressing this key will immediately trigger the sending of dialed string collected so far. In this case, this key is essentially equivalent to the “(Re)Dial” key. If set to “No”, this # key will then be included as part of the dial string to be sent out.
Subscribe for MWI:	Default is NO. When set to Yes a SUBSCRIBE for Message Waiting Indication will be sent periodically.
Send Anonymous	If this parameter is set to “Yes”, user ID will be sent as anonymous, essentially block the Caller ID from displaying.
Lock keypad update	If set to “Yes”, the configuration update via keypad is disabled. NOTE: <i>Since only FXS1 has LED for indication and IVR for keypad access, this field is not applied to FXS2</i>
Special Feature	Default is Standard. Choose the selection to meet some special requirements from Soft Switch vendors like Lucent, Nortel, BroadSoft, etc.
Distinct Ringtones	Using these settings, user can configure ring or tone frequencies according to their preference. By default they are set to North American frequencies. Frequencies should be configured with known values to avoid uncomfortable high pitch sounds. ON is the period of ringing (“On time” in ‘ms’) while OFF is the period of silence. In order to set a continuous ring, OFF should be zero. Otherwise it will ring ON ms and a pause of OFF ms and then repeat the pattern.
Volume Amplification	Handset volume adjustment. RX is for receiving volume, TX is for transmission volume. Default values are 0dB for both parameters. +6dB generates the highest volume and -6dB generates the lowest volume.

6.2.4 Saving the Configuration Changes

Once a change is made, users should click on the “Update” button in the Configuration page. The HandyTone-386 will then display the following screen to confirm that the changes have been saved.

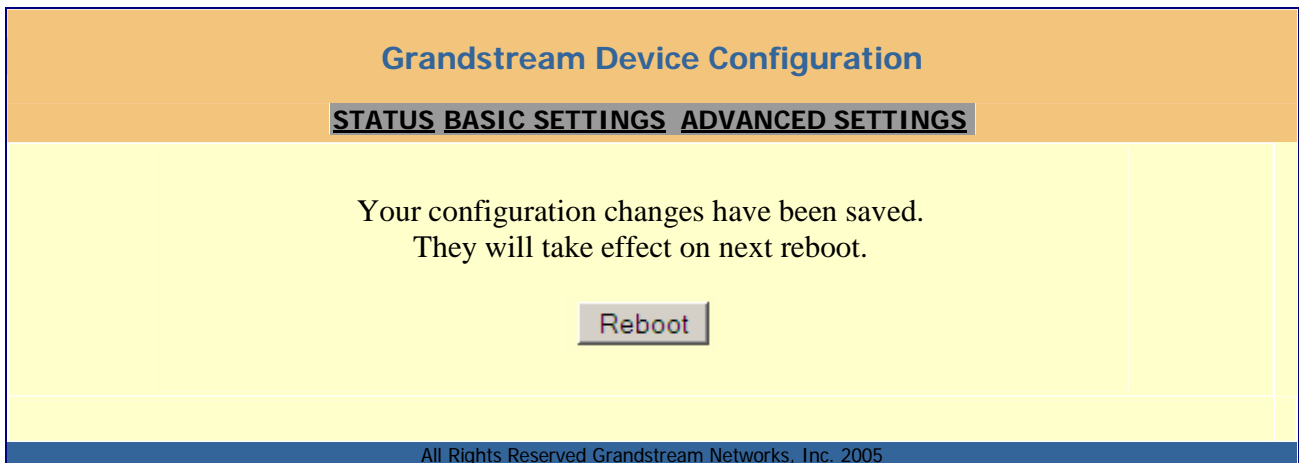

Users are recommended to Reboot the HandyTone-386 after seeing the above message.

6.2.5 Rebooting the HandyTone-386 from Remote

The administrator of the HandyTone-386 can remotely reboot the HT386 by clicking on the “Reboot” button at the bottom of the configuration page. Once done, the following screen will be displayed to indicate that rebooting is underway.

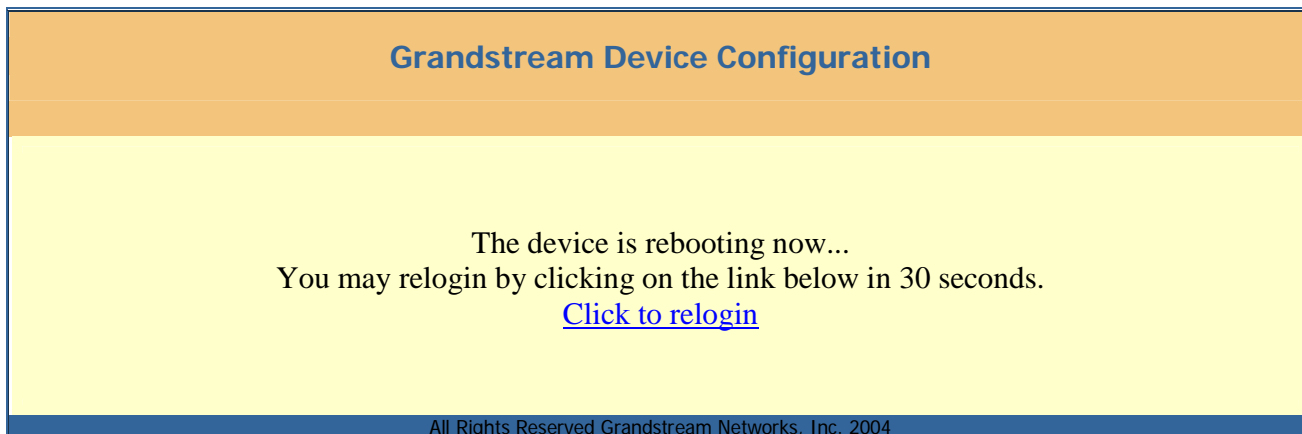

At this point, the user can relogin to the HandyTone-386 after waiting for about 30 seconds.

6.3 Configuration through a Central Server

Grandstream HT386 can be automatically configured from a central provisioning system.

When HT386 boots up, it will send TFTP request to download configuration files, there are two configuration files, one is "cfg.txt" and the other is "cfg000b82xxxxxx", where "000b82xxxxxx" is the MAC address of the HT386.

The configuration files can be downloaded via TFTP from the central server. A service provider or an enterprise with large deployment of HT386 can easily manage the configuration and service provisioning of individual devices remotely from a central server.

Grandstream provides a licensed provisioning package called GAPSLite that can be used to support automated configuration of HandyTone ATA. GAPSLite is a light version of GAPS (Grandstream Automated Provisioning System) that uses enhanced (NAT friendly) TFTP and SIP protocol to communicate with each individual HandyTone ATA for firmware upgrade, remote reboot, etc.

For details on how GAPSLite works, please refer to the documentation of GAPSLite product.

7 Software Upgrade

Software upgrade can be done via either TFTP or HTTP. The corresponding configuration settings are in the ADVANCED SETTINGS configuration page.

7.1 Firmware Upgrade through TFTP/HTTP

To upgrade via TFTP or HTTP, the “Firmware Upgrade and Provisioning upgrade via” field needs to be set to TFTP or HTTP, respectively. “Firmware Server Path” needs to be set to a valid URL of a TFTP or HTTP server, server name can be in either FQDN or IP address format. Here are examples of some valid URL.

e.g. firmware.mycompany.com:6688/Grandstream/1.0.3.44

e.g. 168.75.215.190

NOTES:

- TFTP server in IP address format can be configured via IVR. Please refer to section 6.1.3 for instructions. If TFTP server is in FQDN format, it must be set via web configuration interface.
- Once a “Firmware Server Path” is set, user needs to update the settings and reboot the device. If the configured firmware server is found and a new code image is available, the HandyTone ATA will attempt to retrieve the new image files by downloading them into the HandyTone ATA’s SRAM. During this stage, the HandyTone ATA’s LEDs will blink until the checking/downloading process is completed. Upon verification of checksum, the new code image will then be saved into the Flash. If TFTP/HTTP fails for any reason (e.g., TFTP/HTTP server is not responding, there are no code image files available for upgrade, or checksum test fails, etc), the HandyTone ATA will stop the TFTP/HTTP process and simply boot using the existing code image in the flash.
- Firmware upgrade may take as long as 1 to 20 minutes over Internet, or just 20+ seconds if it is performed on a LAN. It is recommended to conduct firmware upgrade in a controlled LAN environment if possible. For users who do not have a local firmware upgrade server, Grandstream provides a NAT-friendly TFTP server on the public Internet for firmware upgrade. Please check the Services section of Grandstream’s Web site to obtain our public TFTP server’s IP address.
- Alternatively, user can download a free TFTP or HTTP server and conduct local firmware upgrade. A free windows version TFTP server is available for download from <http://support.solarwinds.net/updates/New-customerFree.cfm>. Our latest official release can be downloaded from <http://www.grandstream.com/y-firmware.htm>. Unzip the file and put all of them under the root directory of the TFTP server. Put the PC running the TFTP server and the HandyTone ATA in the same LAN segment. Please go to File -> Configure -> Security to change the TFTP server's default setting from "Receive Only" to "Transmit Only" for the firmware upgrade. Start the TFTP server, in the HandyTone ATA’s web configuration page, configure the Firmware Server Path with the IP address of the PC, update the change and reboot the unit. Please be advised that our client will pull out firmware from the WAN side, if the TFTP server is connected to the device’s LAN port, the firmware upgrade will not work by design.

7.2 Configuration File Download

Grandstream SIP Device can be configured via Web Interface as well as via Configuration File through TFTP or HTTP. “Config Server Path” is the TFTP or HTTP server path for configuration file. It needs to be set to a valid URL, either in FQDN or IP address format. The “Config Server Path” can be same or different from the “Firmware Server Path”.

A configuration parameter is associated with each particular field in the web configuration page. A parameter consists of a Capital letter P and 2 to 3 (Could be extended to 4 in the future) digit numeric numbers. i.e., P2 is associated with “Admin Password” in the ADVANCED SETTINGS page. For a detailed parameter list, please refer to the corresponding firmware release configuration template.

When Grandstream Device boots up or reboots, it will issue request for configuration file named “cfgxxxxxxxxxxxx”, where “xxxxxxxxxxxx” is the MAC address of the device, i.e., “cfg000b820102ab”. The configuration file name should be in lower cases.

7.3 Firmware and Configuration File Prefix and Postfix

Firmware Prefix and Postfix allows device to download the firmware name with the matching Prefix and Postfix. This makes it the possible to store ALL of the firmware with different version in one single directory. Similarly, Config File Prefix and Postfix allows device to download the configuration file with the matching Prefix and Postfix. Thus multiple configuration files for the same device can be stored in one directory.

In addition, when the field “Check New Firmware only when F/W pre/suffix changes” is set to “Yes”, the device will only issue firmware upgrade request if there are changes in the firmware Prefix or Postfix.

7.4 Managing Firmware and Configuration File Download

When “Automatic Upgrade” is set to “Yes”, Service Provider can use P193 (Auto Check Interval, in minutes, default and minimum is 60 minutes) to have the devices periodically check with either Firmware Server or Config Server, whenever they are defined. This allows the device periodically check if there are any new changes need to be taken on a scheduled time. By defining different intervals in P193 for different devices, Server Provider can spread the Firmware or Configuration File download in minutes to reduce the Firmware or Provisioning Server load at any given time.

8 Restore Factory Default Setting

Warning !!!

Restore the Factory Default Setting will DELETE all configuration information of the device. Please backup or print out all the settings before you approach to following steps. Grandstream will not take any responsibility if you lose all the parameters of setting and cannot connect to your service provider.

Please disconnect network cable and power cycle the unit before trying to reset the unit to factory default. The steps are as follows:

Step 1:

Find the MAC Address of the device. It is a 12 digits HEX number located on the bottom of the unit.

Step 2:

Encode the MAC address. Please use the following mapping:

0-9: 0-9
A: 22
B: 222
C: 2222
D: 33
E: 333
F: 3333

For example, if the MAC address is 000b8200e395, it should be encoded as "0002228200333395".

Step 3:

To perform factory reset:

- a. Press "*" or the LED button for voice prompt.
- b. Enter "99" and get the voice prompt "Reset".
- c. Enter the encoded MAC address of the device.
- d. Wait for 15 seconds.

The device will reboot automatically and restore to factory default setting.

9 Glossary of Terms

ADSL

Asymmetric Digital Subscriber Line: Modems attached to twisted pair copper wiring that transmit from 1.5 Mbps to 9 Mbps downstream (to the subscriber) and from 16 kbps to 800 kbps upstream, depending on line distance.

AGC

Automatic Gain Control, is an [electronic system](#) found in many types of devices. Its purpose is to control the [gain](#) of a system in order to maintain some measure of performance over a changing range of real world conditions.

ARP

Address Resolution Protocol is a protocol used by the [Internet Protocol \(IP\)](#) [[RFC826](#)], specifically IPv4, to map [IP network addresses](#) to the hardware addresses used by a data link protocol. The protocol operates below the network layer as a part of the interface between the OSI network and OSI link layer. It is used when [IPv4 is used over Ethernet](#)

ATA

Analogue Telephone Adapter. Covert analogue telephone to be used in data network for VoIP, like Grandstream HT series products.

CODEC

Abbreviation for Coder-Decoder. It's an analog-to-digital (A/D) and digital-to-analog (D/A) converter for translating the signals from the outside world to digital, and back again.

CNG

Comfort Noise Generator, generate artificial background [noise](#) used in [radio](#) and [wireless](#) communications to fill the [silent](#) time in a transmission resulting from [voice activity detection](#).

DATAGRAM

A data packet carrying its own address information so it can be independently routed from its source to the destination computer

DECIMATE

To discard portions of a signal in order to reduce the amount of information to be encoded or compressed. Lossy compression algorithms ordinarily decimate while subsampling.

DECT

Digital Enhanced Cordless Telecommunications: A standard developed by the European Telecommunication Standard Institute from 1988, governing pan-European digital mobile

telephony. DECT covers wireless PBXs, telepoint, residential cordless telephones, wireless access to the public switched telephone network, Closed User Groups (CUGs), Local Area Networks, and wireless local loop. The DECT Common Interface radio standard is a multicarrier time division multiple access, time division duplex (MC-TDMA-TDD) radio transmission technique using ten radio frequency channels from 1880 to 1930 MHz, each divided into 24 time slots of 10ms, and twelve full-duplex accesses per carrier, for a total of 120 possible combinations. A DECT base station (an RFP, Radio Fixed Part) can transmit all 12 possible accesses (time slots) simultaneously by using different frequencies or using only one frequency. All signaling information is transmitted from the RFP within a multiframe (16 frames). Voice signals are digitally encoded into a 32 kbit/s signal using Adaptive Differential Pulse Code Modulation.

DNS

Short for *Domain Name System* (or *Service* or *Server*), an [Internet](#) service that translates [domain names](#) into IP addresses

DID

Direct Inward Dialing

Direct Inward Dialing. The ability for an outside caller to dial to a PBX extension without going through an attendant or auto-attendant.

DSP

Digital Signal Processing. Using computers to process signals such as sound, video, and other analog signals which have been converted to digital form.

Digital Signal Processor. A specialized CPU used for digital signal processing.

Grandstream products all have DSP chips built inside.

DTMF

Dual Tone Multi Frequency

The standard tone-pairs used on telephone terminals for dialing using in-band signaling. The standards define 16 tone-pairs (0-9, #, * and A-F) although most terminals support only 12 of them (0-9, * and #).

FQDN

Fully Qualified Domain Name

A FQDN consists of a host and domain name, including top-level domain. For example, [www.grandstream.com](#) is a fully qualified domain name. www is the host, grandstream is the second-level domain, and.com is the top level domain.

FXO

Foreign eXchange Office

An FXO device can be an analog phone, answering machine, fax, or anything that handles a call from the telephone company like AT&T. They should also operate the same way when connected to an FXS interface.

An FXO interface will accept calls from FXS or PSTN interfaces. All countries and regions have their own standards.

FXO is complimentary to FXS (and the PSTN).

FXS

Foreign eXchange Station

An FXS device has hardware to generate the ring signal to the FXO extension (usually an analog phone).

An FXS device will allow any FXO device to operate as if it were connected to the phone company. This makes your PBX the POTS+PSTN for the phone.

The FXS Interface connects to FXO devices (by an FXO interface, of course).

DHCP

The *Dynamic Host Configuration Protocol* (DHCP) is an Internet protocol for automating the configuration of computers that use TCP/IP. DHCP can be used to automatically assign IP addresses, to deliver TCP/IP stack configuration parameters such as the subnet mask and default router, and to provide other configuration information such as the addresses for printer, time and news servers.

ECHO CANCELLATION

Echo Cancellation is used in [telephony](#) to describe the process of removing [echo](#) from a voice communication in order to improve voice quality on a [telephone call](#). In addition to improving quality, this process improves [bandwidth](#) savings achieved through [silence suppression](#) by preventing echo from traveling across a [network](#).

There are two types of echo of relevance in telephony: acoustic echo and hybrid echo. [Speech compression](#) techniques and [digital processing](#) delay often contribute to echo generation in [telephone networks](#).

H.323

A suite of standards for multimedia conferences on traditional packet-switched networks.

HTTP

Hyper Text Transfer Protocol; the World Wide Web protocol that performs the request and retrieve functions of a server

IP

Internet Protocol. A packet-based protocol for delivering data across networks.

IP-PBX

IP-based Private Branch Exchange

IP Telephony

(Internet Protocol telephony, also known as Voice over IP Telephony) A general term for the technologies that use the Internet Protocol's packet-switched connections to exchange voice, fax, and other forms of information that have traditionally been carried over the dedicated circuit-switched connections of the public switched telephone network (PSTN). The basic steps involved in originating an IP Telephony call are conversion of the analog voice signal to digital format and compression/translation of the signal into Internet protocol (IP) packets for transmission over the Internet or other packet-switched networks; the process is reversed at the receiving end. The terms IP Telephony and Internet Telephony are often used to mean the same; however, they are not 100 per cent interchangeable, since Internet is only a subcase of packet-switched networks. For users who have free or fixed-price Internet access, IP Telephony software essentially provides free telephone calls anywhere in the world. However, the challenge of IP Telephony is maintaining the quality of service expected by subscribers. Session border controllers resolve this issue by providing quality assurance comparable to legacy telephone systems.

IVR

IVR is a software application that accepts a combination of voice telephone input and touch-tone keypad selection and provides appropriate responses in the form of voice, fax, callback, e-mail and perhaps other media.

MTU

A Maximum Transmission Unit (MTU) is the largest size [packet](#) or [frame](#), specified in [octets](#) (eight-bit bytes), that can be sent in a packet- or frame-based network such as the Internet. The maximum for Ethernet is 1500 byte.

NAT

Network Address Translation

NTP

Network Time Protocol, a protocol to exchange and synchronize time over networks
The port used is UDP 123
Grandstream products using NTP to get time from Internet

OBP/SBC

Outbound Proxy or another name Session Border Controller. A device used in [VoIP](#) networks. OBP/SBCs are put into the signaling and media path between calling and called party. The OBP/SBC acts as if it was the called VoIP phone and places a second call to the called party. The effect of this behaviour is that not only the signaling traffic, but also the media traffic (voice, video etc) crosses the OBP/SBC. Without an OBP/SBC, the media traffic travels directly between the VoIP phones. Private OBP/SBCs are used along with [firewalls](#) to enable VoIP calls to and from a protected enterprise network. Public VoIP service providers use OBP/SBCs to allow the use of VoIP protocols from private networks with [internet](#) connections using [NAT](#).

PPPoE

Point-to-Point Protocol over Ethernet, is a network protocol for encapsulating PPP frames in Ethernet frames. It is used mainly with cable modem and DSL services.

PSTN

Public Switched Telephone Network

i.e. the phone service we use for every ordinary phone call, or called POT (Plain Old Telephone), or circuit switched network.

RTCP

Real-time Transport Control Protocol, defined in [RFC 3550](#), a sister protocol of the [Real-time Transport Protocol](#) (RTP), It partners RTP in the delivery and packaging of multimedia data, but does not transport any data itself. It is used periodically to transmit control packets to participants in a streaming multimedia session. The primary function of RTCP is to provide feedback on the quality of service being provided by RTP.

RTP

Real-time Transport Protocol defines a standardized packet format for delivering audio and video over the Internet. It was developed by the Audio-Video Transport Working Group of the [IETF](#) and first published in 1996 as [RFC 1889](#)

SDP

Session Description Protocol, is a format for describing [streaming media](#) initialization parameters. It has been published by the [IETF](#) as [RFC 2327](#).

SIP

Session Initiation Protocol, An IP telephony signaling protocol developed by the IETF (RFC3261). SIP is a text-based protocol suitable for integrated voice-data applications. SIP is

designed for voice transmission and uses fewer resources and is considerably less complex than H.323.

All Grandstream products are SIP based

STUN

Simple Traversal of UDP over NATs, is a [network protocol](#) allowing clients behind [NAT](#) (or multiple NATs) to find out its public address, the type of NAT it is behind and the internet side port associated by the NAT with a particular local port. This information is used to set up UDP communication between two hosts that are both behind NAT routers. The protocol is defined in [RFC 3489](#). STUN will usually work good with non-symmetric NAT routers.

TCP

Transmission Control Protocol, is one of the core protocols of the [Internet protocol suite](#). Using TCP, applications on networked hosts can create *connections* to one another, over which they can exchange data or [packets](#). The protocol guarantees reliable and in-order delivery of sender to receiver data.

TFTP

Trivial File Transfer Protocol, is a very simple [file transfer protocol](#), with the functionality of a very basic form of [FTP](#); It uses [UDP](#) (port 69) as its [transport protocol](#).

UDP

User Datagram Protocol (UDP) is one of the core protocols of the [Internet protocol suite](#). Using UDP, programs on networked computers can send short messages known as [datagrams](#) to one another. UDP does not provide the reliability and ordering guarantees that [TCP](#) does; datagrams may arrive out of order or go missing without notice. However, as a result, UDP is faster and more efficient for many lightweight or time-sensitive purposes.

VAD

Voice Activity Detection or Voice Activity Detector is an algorithm used in [speech processing](#) wherein, the presence or absence of human speech is detected from the audio samples.

VLAN

A virtual [LAN](#), known as a VLAN, is a logically-independent [network](#). Several VLANs can co-exist on a single physical [switch](#). It is usually refer to the [IEEE 802.1Q](#) tagging protocol.

VoIP

Voice over IP

VoIP encompasses many protocols. All the protocols do some form of signalling of call capabilities and transport of voice data from one point to another. e.g: SIP, H.323, etc.