

Extron Electronics

INTERFACING, SWITCHING AND DISTRIBUTION

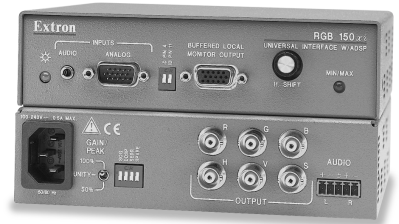

User's Manual



RGB 130xi, 134xi, 150xi Universal Interfaces

Precautions

Safety Instructions • English



This symbol is intended to alert the user of important operating and maintenance (servicing) instructions in the literature provided with the equipment.



This symbol is intended to alert the user of the presence of uninsulated dangerous voltage within the product's enclosure that may present a risk of electric shock.

Caution

Read Instructions • Read and understand all safety and operating instructions before using the equipment.

Retain Instructions • The safety instructions should be kept for future reference.

Follow Warnings • Follow all warnings and instructions marked on the equipment or in the user information.

Avoid Attachments • Do not use tools or attachments that are not recommended by the equipment manufacturer because they may be hazardous.

Consignes de Sécurité • Français



Ce symbole sert à avertir l'utilisateur que la documentation fournie avec le matériel contient des instructions importantes concernant l'exploitation et la maintenance (réparation).



Ce symbole sert à avertir l'utilisateur de la présence dans le boîtier de l'appareil de tensions dangereuses non isolées posant des risques d'électrocution.

Attention

Lire les instructions • Prendre connaissance de toutes les consignes de sécurité et d'exploitation avant d'utiliser le matériel.

Conservier les instructions • Ranger les consignes de sécurité afin de pouvoir les consulter à l'avenir.

Respecter les avertissements • Observer tous les avertissements et consignes marqués sur le matériel ou présentés dans la documentation utilisateur.

Eviter les pièces de fixation • Ne pas utiliser de pièces de fixation ni d'outils non recommandés par le fabricant du matériel car cela risquerait de poser certains dangers.

Sicherheitsanleitungen • Deutsch



Dieses Symbol soll den Benutzer auf wichtige Anleitungen zur Bedienung und Wartung (Instandhaltung) in der Dokumentation hinweisen, die im Lieferumfang dieses Gerätes enthalten ist.



Dieses Symbol soll den Benutzer darauf aufmerksam machen, daß im Inneren des Gehäuses dieses Produktes gefährliche Spannungen, die nicht isoliert sind und die einen elektrischen Schock verursachen können, herrschen.

Achtung

Lesen der Anleitungen • Bevor Sie das Gerät zum ersten Mal verwenden, sollten Sie alle Sicherheits- und Bedienungsanleitungen genau durchlesen und verstehen.

Aufbewahren der Anleitungen • Die Sicherheitsanleitungen sollten aufbewahrt werden, damit Sie später darauf zurückgreifen können.

Befolgen der Warnhinweise • Befolgen Sie alle Warnhinweise und Anleitungen auf dem Gerät oder in der Benutzerdokumentation.

Keine Zusatzgeräte • Verwenden Sie keine Werkzeuge oder Zusatzgeräte, die nicht ausdrücklich vom Hersteller empfohlen wurden, da diese eine Gefahrenquelle darstellen können.

Instrucciones de seguridad • Español



Este símbolo se utiliza para advertir al usuario sobre instrucciones importantes de operación y mantenimiento (o cambio de partes) que se desean destacar en el contenido de la documentación suministrada con los equipos.



Este símbolo se utiliza para advertir al usuario sobre la presencia de elementos con voltaje peligroso sin protección aislante, que puedan encontrarse dentro de la caja o alojamiento del producto, y que puedan representar riesgo de electrocución.

Precaución

Leer las instrucciones • Leer y analizar todas las instrucciones de operación y seguridad, antes de usar el equipo.

Conservar las instrucciones • Conservar las instrucciones de seguridad para futura consulta.

Obedecer las advertencias • Todas las advertencias e instrucciones marcadas en el equipo o en la documentación del usuario, deben ser obedecidas.

Evitar el uso de accesorios • No usar herramientas o accesorios que no sean específicamente recomendados por el fabricante, ya que podrían implicar riesgos.

Warning

Power sources • This equipment should be operated only from the power source indicated on the product. This equipment is intended to be used with a main power system with a grounded (neutral) conductor. The third (grounding) pin is a safety feature, do not attempt to bypass or disable it.

Power disconnection • To remove power from the equipment safely, remove all power cords from the rear of the equipment, or the desktop power module (if detachable), or from the power source receptacle (wall plug).

Power cord protection • Power cords should be routed so that they are not likely to be stepped on or pinched by items placed upon or against them.

Servicing • Refer all servicing to qualified service personnel. There are no user-serviceable parts inside. To prevent the risk of shock, do not attempt to service this equipment yourself because opening or removing covers may expose you to dangerous voltage or other hazards.

Slots and openings • If the equipment has slots or holes in the enclosure, these are provided to prevent overheating of sensitive components inside. These openings must never be blocked by other objects.

Lithium battery • There is a danger of explosion if battery is incorrectly replaced. Replace it only with the same or equivalent type recommended by the manufacturer. Dispose of used batteries according to the manufacturer's instructions.

Avvertimento

Alimentazioni • Ne faire fonctionner ce matériel qu'avec la source d'alimentation indiquée sur l'appareil. Ce matériel doit être utilisé avec une alimentation principale comportant un fil de terre (neutre). Le troisième contact (de mise à la terre) constitue un dispositif de sécurité - n'essayez pas de la contourner ni de la désactiver.

Deconnexión de l'alimentation • Pour mettre le matériel hors tension sans danger, déconnectez tous les cordons d'alimentation de l'arrière de l'appareil ou du module d'alimentation de bureau (s'il est amovible) ou encore de la prise secteur.

Protection du cordon d'alimentation • Acheminer les cordons d'alimentation de manière à ce que personne ne risque de marcher dessus et à ce qu'ils ne soient pas écrasés ou pincés par des objets.

Réparation-maintenance • Faire exécuter toutes les interventions de réparation-maintenance par un technicien qualifié. Aucun des éléments internes ne peut être réparé par l'utilisateur. Afin d'éviter tout danger d'électrocution, l'utilisateur ne doit pas essayer de procéder lui-même à ces opérations car l'ouverture ou le retrait des couvercles risquent de l'exposer à de hautes tensions et autres dangers.

Fentes et orifices • Si le boîtier de l'appareil comporte des fentes ou des orifices, ceux-ci servent à empêcher les composants internes sensibles de surchauffer. Ces ouvertures ne doivent jamais être bloquées par des objets.

Lithium Batterie • Il y a danger d'explosion s'il y a remplacement incorrect de la batterie. Remplacer uniquement avec une batterie du même type ou d'un type équivalent recommandé par le constructeur. Mettre au rebut les batteries usagées conformément aux instructions du fabricant.

Vorsicht

Stromquellen • Dieses Gerät sollte nur über die auf dem Produkt angegebene Stromquelle betrieben werden. Dieses Gerät wurde für eine Verwendung mit einer Hauptstromleitung mit einem geerdeten (neutralen) Leiter konzipiert. Der dritte Stift oder Kontakt ist für einen Erdschluß, und stellt eine Sicherheitsfunktion dar und sollte nicht umgangen oder außer Betrieb gesetzt werden.

Stromunterbrechung • Um das Gerät auf sichere Weise vom Netz zu trennen, sollten Sie alle Netzkabeln aus der Rückseite des Gerätes oder aus dem Desktop-Strommodul (falls dies möglich ist) oder aus der Wandsteckdose ziehen.

Schutz des Netzkabels • Netzkabel sollten stets so verlegt werden, daß sie nicht im Weg liegen und niemand darauf treten kann oder Objekte darauf- oder unmittelbar dagegen gestellt werden können.

Wartung • Alle Wartungsmaßnahmen sollten nur von qualifiziertem Servicepersonal durchgeführt werden. Im Inneren des Gerätes sind keine Teile enthalten, die vom Benutzer gewartet werden können. Zur Vermeidung eines elektrischen Schocks versuchen Sie in keinem Fall, dieses Gerät selbst zu warten, da beim Öffnen oder Entfernen der Abdeckungen die Gefahr eines elektrischen Schlags oder anderer Gefahren bestehen.

Schlitze und Öffnungen • Wenn das Gerät Schlitze oder Löcher im Gehäuse aufweist, dienen diese zur Vermeidung einer Überhitzung der empfindlichen Teile im Inneren. Diese Öffnungen dürfen niemals von anderen Objekten blockiert werden.

Lithium-Batterie • Explosionsgefahr, falls die Batterie nicht richtig ersetzt wird. Ersetzen Sie nur durch diegleiche oder einen vergleichbaren Batterietyp, der auch vom Hersteller empfohlen wird. Entsorgung der verbrauchten Batterien bitte gemäß den Herstelleranweisungen.

Advertencia

Alimentación eléctrica • Este equipo debe conectarse únicamente a la fuente/tipo de alimentación eléctrica indicada en el mismo. La alimentación eléctrica de este equipo debe provenir de un sistema de distribución general con conductor neutro a tierra. La tercera pata (puesta a tierra) es una medida de seguridad, no puentearla ni eliminarla.

Desconexión de alimentación eléctrica • Para desconectar con seguridad la acometida de alimentación eléctrica al equipo, desenchufar todos los cables de alimentación en el panel trasero del equipo, o desenchufar el módulo de alimentación (si fuera independiente), o desenchufar el cable del receptáculo de la pared.

Protección de los cables de alimentación • Los cables de alimentación eléctrica se deben instalar en lugares donde no sean pisados ni apretados por objetos que se puedan apoyar sobre ellos.

Reparaciones/mantenimiento • Solicitar siempre los servicios técnicos de personal calificado. En el interior no hay partes a las que el usuario deba acceder. Para evitar riesgo de electrocución, no intentar personalmente la reparación/mantenimiento de este equipo, ya que al abrir o extraer las tapas puede quedar expuesto a voltajes peligrosos u otros riesgos.

Ranuras y aberturas • Si el equipo posee ranuras o orificios en su caja/alostamiento, es para evitar el sobrecalentamiento de componentes internos sensibles. Estas aberturas nunca se deben obstruir con otros objetos.

Batería de litio • Existe riesgo de explosión si esta batería se coloca en la posición incorrecta. Cambiar esta batería únicamente con el mismo tipo (o su equivalente) recomendado por el fabricante. Deschar las baterías usadas siguiendo las instrucciones del fabricante.

Table of Contents

Chapter 1 • Introduction	1-1
About this Manual	1-1
About the Interfaces	1-1
Features	1-1
Chapter 2 • Controls and Installation	2-1
Front and Rear Panels	2-1
RGB 150 <i>x</i> i front panel features	2-1
RGB 150 <i>x</i> i rear panel features	2-2
RGB 130 <i>x</i> i front panel features	2-3
RGB 130 <i>x</i> i rear panel features	2-4
RGB 134 <i>x</i> i front panel features	2-5
RGB 134 <i>x</i> i rear panel features	2-6
Installation	2-7
Easy setup procedure	2-7
Mounting the interface	2-8
Cabling	2-10
Connecting audio output	2-12
Setting the DIP switches	2-14
Setting internal jumpers	2-16
Appendix	A-1
Specifications	A-1
Accessories and Part Numbers	A-4
Mounting Templates	A-6



RGB 130*xi*, 134*xi*, 150*xi*

1

Chapter One

Introduction

About this Manual

About the Interfaces

Features

Introduction

About this Manual

This manual documents three universal interfaces: RGB 130*x*_i, RGB 134*x*_i, and RGB 150*x*_i. Unless otherwise specified, any references to “the interface” shall refer to the features or operation of all three interfaces.

About the Interfaces

The RGB 130*x*_i, 134*x*_i, and 150*x*_i are universal interfaces with a video bandwidth of 300 MHz and a horizontal frequency range of 15-150 kHz.

Features

2-color power/signal LED — When the interface is On, the power/signal LED will light amber. When the interface is On and a signal is present, the LED will light green.

Gain/peak control— Increases signal voltages to compensate for signal degradation caused by long cable lengths.

Stereo audio — Front panel audio input and a 3.5 mm captive screw output connector on the rear panel.

Horizontal and vertical shift — The picture can be shifted horizontally and vertically for the RGB 130*x*_i and RGB 134*x*_i. The RGB 150*x*_i offers horizontal shifting only. A min/max LED indicator lights red whenever the shifting reaches its lower and upper limits.

ADSP™ (Advanced digital sync processing) — Allows sync processing operations, such as horizontal centering, to occur without affecting the signal’s sync timing. This allows horizontal centering to be applied to signals that are output to digital display devices, such as LCD projectors, DLP (digital light amplifier) projectors, and plasma displays.

Under/through desk mounting — The interfaces are capable of being mounted either under or through a desk or other suitable surface using the optional mounting kit.



RGB 130*xi*, 134*xi*, 150*xi*

Chapter Two

Controls and Installation

Front and Rear Panels

Installation

Controls and Installation

Front and Rear Panels

RGB 150*x*i front panel features

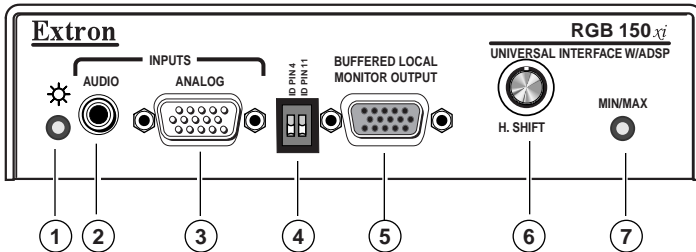

Figure 2-1 — RGB 150*x*i front panel

- ① **2-color power/signal LED** — lights amber to indicate power On only; lights green to indicate power On with video signal present
- ② **Audio input jack** — 3.5 mm stereo input
- ③ **Analog input connector** — HD 15-pin male analog video input connector
- ④ **ID bit termination DIP switches** — provides proper ID bit termination for a laptop computer that is not attached to a local monitor
- ⑤ **Buffered local monitor output** — HD 15-pin female for output to a local monitor
- ⑥ **Horizontal shift control knob** — adjusts horizontal shifting of the remote output display device
- ⑦ **Min/max LED** — lights red whenever the lower and upper limits of the horizontal shift control are reached

RGB 150xi rear panel features

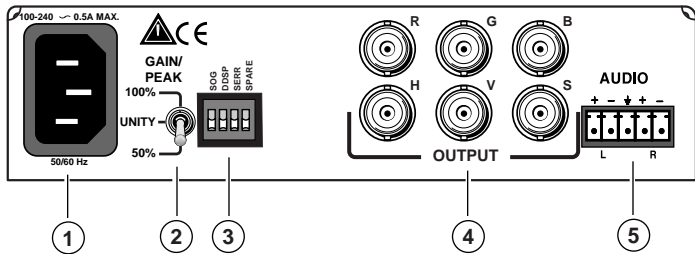

Figure 2-2 — RGB 150xi rear panel

- 1 AC power input** — standard IEC AC power connector (100 - 240VAC 50/60 Hz)
- 2 3-position gain/peak switch** — unity*; gain with 50% peaking; and gain with 100% peaking
- 3 DIP switches** — 4 switches to control sync on green on output, Digital Display Sync Processing, serration pulse, and a spare (refer to the section “*Setting the DIP switches*”)
- 4 BNC output** — 6 BNC connectors to output RGsB, RGSB, and RGBHV
- 5 Stereo audio output** — 3.5 mm captive screw audio connector

* *Unity sets the output level equivalent to the input, with no added peaking*

NOTE

If the signal cable between the interface and the display device is shorter than approximately 125 feet, and the level/peak switch is set to a setting other than Unity, the image may be overcompensated. If the edges of the image seem to exceed their boundaries, or if thin lines and sharp edges look thick and fuzzy, try changing the gain/peak setting.

RGB 130*x*i front panel features

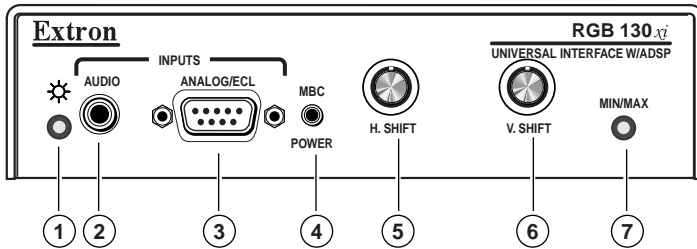

Figure 2-3 — RGB 130*x*i front panel

- ① **2-color power/signal LED** — lights amber to indicate power On only; lights green to indicate power On with video signal present
- ② **Audio input jack** — 3.5 mm stereo input
- ③ **Analog/ECL input connector** — 9-pin D male analog video input connector
- ④ **MBC power** — 2.5 mm jack provides power for MBC buffer
- ⑤ **Horizontal shift control knob** — adjusts horizontal shifting of the remote output display device
- ⑥ **Vertical shift control knob** — adjusts vertical shifting of the remote output display device
- ⑦ **Min/max LED** — lights red whenever the lower and upper limits of the horizontal/vertical shift control are reached

RGB 130*x*i rear panel features

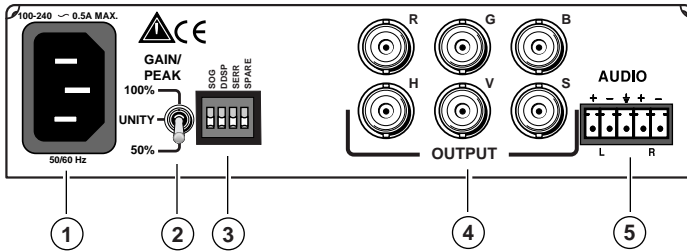

Figure 2-4 — RGB 130*x*i rear panel

- ① **AC power input** — standard IEC AC power connector (100 - 240VAC 50/60 Hz)
- ② **3-position gain/peak switch** — unity*; gain with 50% peaking; and gain with 100% peaking
- ③ **DIP switches** — 4 switches to control sync on green on output, Digital Display Sync Processing, serration pulse, and 75-ohm input termination (refer to the section “Setting the DIP switches”)
- ④ **BNC output** — 6 BNC connectors to output RGsB, RGBS, and RGBHV
- ⑤ **Stereo audio output** — 3.5 mm captive screw audio connector

* *Unity sets the output level equivalent to the input, with no added peaking.*

NOTE

If the signal cable between the interface and the display device is shorter than approximately 125 feet, and the level/peak switch is set to a setting other than Unity, the image may be overcompensated. If the edges of the image seem to exceed their boundaries, or if thin lines and sharp edges look thick and fuzzy, try changing the gain/peak setting.

RGB 134*x*i front panel features

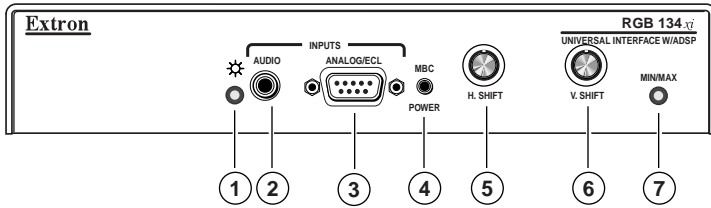

Figure 2-5 — RGB 134*x*i front panel

- ① **2-color power/signal LED** — lights amber to indicate power On only; lights green to indicate power On with video signal present
- ② **Audio input jack** — 3.5 mm stereo input
- ③ **Analog/ECL input connector** — 9-pin D male analog video input connector
- ④ **MBC power** — 2.5 mm jack provides power for MBC buffer
- ⑤ **Horizontal shift control knob** — adjusts horizontal shifting of the remote output display device
- ⑥ **Vertical shift control knob** — adjusts vertical shifting of the remote output display device
- ⑦ **Min/max LED** — lights red whenever the lower and upper limits of the horizontal shift control are reached

RGB 134*xi* rear panel features

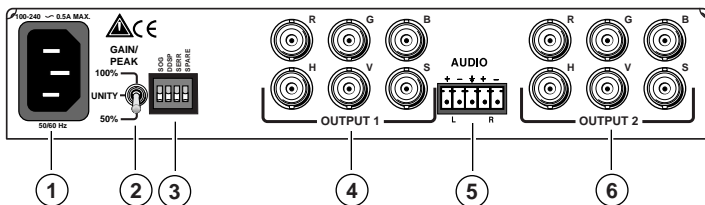

Figure 2-6 — RGB 134*xi* rear panel

- ① **AC power input** — standard IEC AC power connector (100 - 240VAC 50/60 Hz)
- ② **3-position gain/peak switch** — unity*; gain with 50% peaking; and gain with 100% peaking
- ③ **DIP switches** — 4 switches to control sync on green on output, Digital Display Sync Processing, serration pulse, and a 75-ohm input termination (refer to the section “Setting the DIP switches”)
- ④ **BNC output 1** — 6 BNC connectors to output RGsB, RGSB, and RGBHV
- ⑤ **Stereo audio output** — 3.5 mm captive screw audio connector
- ⑥ **BNC output 2** — 6 BNC connectors to output RGsB, RGSB, and RGBHV

* *Unity sets the output level equivalent to the input, with no added peaking.*

NOTE

If the signal cable between the interface and the display device is shorter than approximately 125 feet, and the level/peak switch is set to a setting other than Unity, the image may be overcompensated. If the edges of the image seem to exceed their boundaries, or if thin lines and sharp edges look thick and fuzzy, try changing the gain/peak setting.

Installation

Easy setup procedure

Except where noted, the installation procedures for the RGB 130*xj*, 134*xj*, and 150*xj* are the same. See “Cabling” in this chapter for more information.

- 1 If desired, mount the interface to a desk or other suitable surface using Extron's optional mounting kit. See “Mounting the interface” in the next section.
- 2 Turn off power to the computer or workstation and its monitor. Turn off power to the projector or display device. Disconnect the power cord from the interface.
- 3 Connect the computer to the Analog/ECL* input connector on the front of the interface. If an MBC interface output cable is being used with the RGB 134*xj*, connect the MBC cable to the Analog/ECL connector and connect the MBC power cable to the MBC power jack. Refer to the diagram in the “Cabling” section of this chapter.
- 4 For the RGB 150*xj*, if a local computer monitor is being used, connect the monitor to the Buffered Local Monitor Output connector.
- 5 For audio connections, please refer to the following “Cabling” and “Connecting audio output” sections.
- 6 Connect the projector or other output display device to the interface's BNC output connectors, as described in the “Cabling” section.
- 7 Set the interface's DIP switches. Refer to the section “Setting the DIP switches” at the end of this chapter.
- 8 Power on the computer, monitor, projector/display device, and the interface. The image should now display on screen. If it does not, double check steps 2 through 7 and make adjustments as needed. To adjust horizontal and vertical sync polarity and to set vertical sync pulse width, please refer to the “*Setting internal jumpers*” section at the end of this chapter.

* RGB 150*xj* is analog only

Mounting the interface

To mount the interface under a desk or in a podium, do the following:

1. Attach the mounting brackets to the interface using six machine screws supplied with the mounting kit (see figure 2-7).

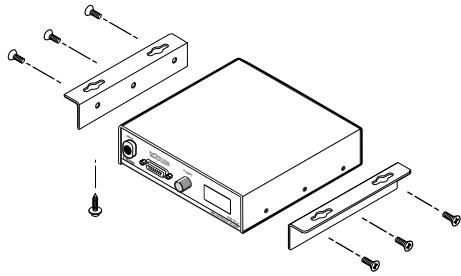

Figure 2-7 — Attaching the under desk brackets

2. Using the to-scale template at the back of this manual to guide you, mark the four screw holes on the underside of the surface to which you are mounting the interface. Use the under desk mounting template.
3. Drill four pilot holes, each $3/32$ " in diameter by $1/4$ " deep, where marked.
4. Using the four wood screws provided, attach the brackets under the mounting surface (see figure 2-8).

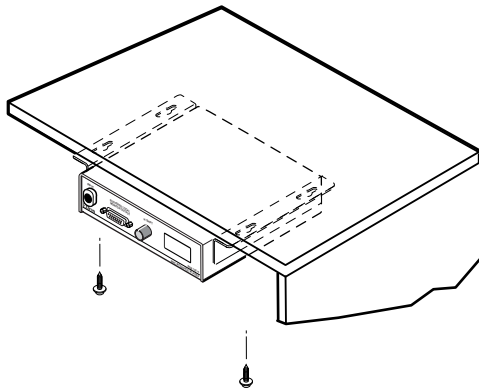

Figure 2-8 — Mounting the interface under a desk

Controls and Installation, cont'd

To mount the interface through a desk or table, do the following:

1. Attach the mounting brackets to the interface using four machine screws and washers (supplied with the mounting kit), as indicated in figure 2-9.

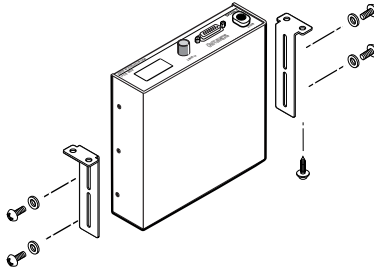

Figure 2-9 — Attaching the through desk brackets

2. Using the to-scale template at the back of this manual to guide you, mark the four screw holes on the underside of the surface to which you are mounting the interface. Use the through desk mounting template to cut the hole.
3. Drill four pilot holes, each $3/32$ " in diameter by $1/4$ " deep, where marked.
4. Using the four wood screws provided, attach the brackets to the mounting surface, as shown in figure 2-10.

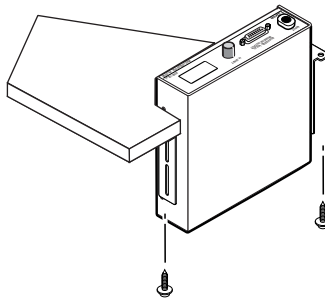

Figure 2-10 — Mounting the interface in a table

Cabling

Each interface can connect to the computer or workstation's local monitor and to a projector or other display device.

The diagrams below show how to connect each of the interfaces.

1. Connect the computer to the interface's Analog/ECL connector.

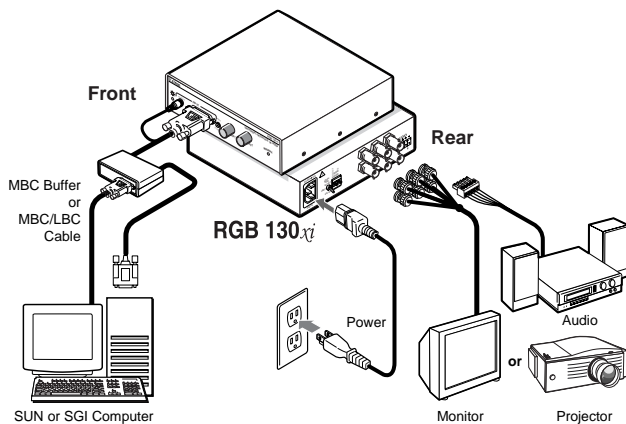

Figure 2-11 — RGB 130xi installation

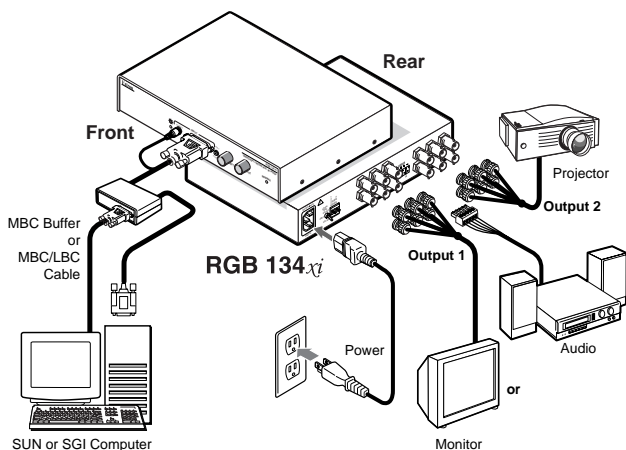

Figure 2-12 — RGB 134xi installation

Controls and Installation, cont'd

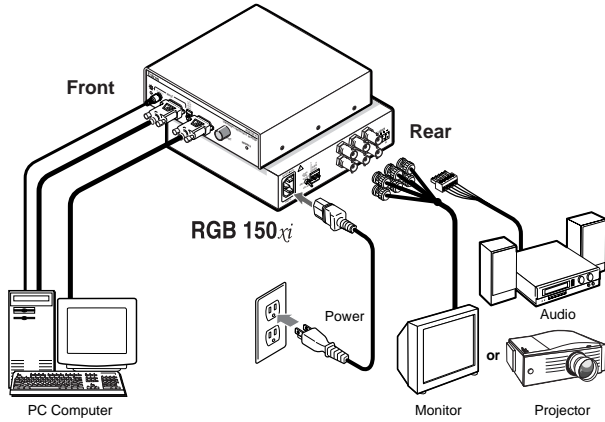

Figure 2-13 — RGB 150xi installation

2. Connect the interface cable marked “Video input” to the computer’s video output (where the monitor was originally connected).
3. For audio connections, refer to the following “Connecting Audio” section for important information concerning unbalanced and balanced audio. Connect audio input to the interface’s front panel audio input jack. Connect audio output to the captive screw connector on the interface’s rear panel.
4. Use BNC cables to attach the interface to a projector or other display device.



RGsB – If coax cables are connected and terminated (75 ohms) to the red, green, and blue channels only, and the SOG OUT switch is set to on (see page 2-14), the output will be sync on green.



RGBS – If the S (composite sync) cable is connected, the output will be composite sync.



RGBHV – If both the H & V cables are connected, the sync output is separate horizontal and vertical.

Connecting audio output

Before connecting audio, determine whether your audio system is unbalanced or balanced. Then, follow the instructions below to connect unbalanced audio, or the instructions for “Balanced audio” to connect balanced audio.

WARNING

Wiring the audio incorrectly may damage the audio output circuits.

Unbalanced audio

To attach the interface to an unbalanced audio system, do the following:

1. Attach the audio cable to an unbalanced powered speaker input connector (tip and sleeve), as shown here.

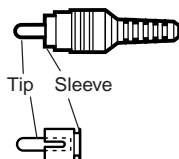

2. Attach the audio cable to the audio cable connector (Extron part number 10-319-10). Fasten the captive screws inside the audio cable connector as shown in figure 2-14.

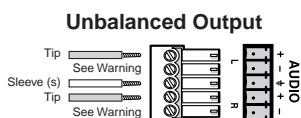

WARNING

Connect the sleeve(s) to ground (GND). Connecting the sleeve(s) to a negative (-) terminal will damage audio output circuits.

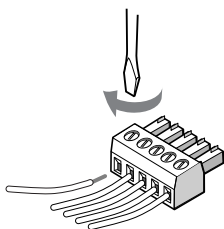

Figure 2-14 — Fastening captive screws

Controls and Installation, cont'd

- Slide the audio cable connector into the audio output connector on the interface.

Balanced audio

To attach the interface to a balanced audio system, do the following:

- Attach the audio cable to a balanced speaker input connector (tip, ring, and sleeve).

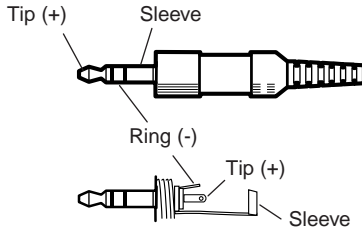

- Attach the audio cable to the audio cable connector (Extron part number 10-319-10). Fasten the captive screws inside the audio cable connector as shown in figure 2-14.

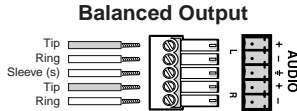

WARNING

*Connect the sleeve(s) to ground (GND).
Connecting the sleeve(s) to a negative (-)
terminal will damage audio output circuits.*

- Slide the audio cable connector into the audio output connector on the interface.

Setting the DIP switches

DIP switches can be found on the front panel of the RGB 150*x*_i and on the rear panels of the RGB 150*x*_i, 130*x*_i, and 134*x*_i. The switches may be either the rocking type or the sliding type.

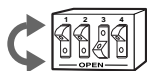

To set the rocking-type DIP switches, use a small screwdriver to depress the appropriate end of each switch.

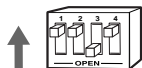

To set the sliding-type DIP switches, use a small screwdriver to slide the switch to the on/closed or off/open position.



The RGB 150*x*_i has two pin termination DIP switches to provide proper ID bit termination for a laptop computer that is not attached to a local monitor.

ID PIN 4 & ID PIN 11

ON — Set both pins to On if you are using the RGB 150*x*_i interface with a laptop computer that *is not* attached to a local monitor.

OFF — Set both pins to Off if you are attaching a local monitor to the interface.



The RGB 130*x*_i, 134*x*_i, and 150*x*_i have four DIP switches on the rear panel to control: sync on green output, digital display sync processing, serration pulse, and 75-ohm input termination (except for the RGB 150*x*_i which has a spare).

SOG (sync on green output)

ON — If this switch is set to On, the interface outputs a composite sync signal on top of the green video signal via the G output connector (RGsB).

OFF — If the SOG feature is set to Off, output is RGBS or RGBHV, depending on how the interface and projector are cabled.

DDSP™ (digital display sync processing)

ON — If this switch is set to On, the interface does not perform sync processing. This may be necessary for digital display

Controls and Installation, cont'd

devices, such as LCD (liquid crystal display), DLP (digital lamp processing) and plasma displays.

OFF — If this switch is set to Off, the interface performs sync processing operations, such as horizontal shift, using Extron's ADSP™.

NOTE *Turning on the DDSP feature disables the horizontal shift control.*

SERR (serration pulse)

Many display devices, such as LCD and DLP projectors and plasma displays, must not have serration pulses present in the sync signal in order to display images properly. Flagging or bending at the top of the video image is a sign that the serration pulses should not be present.

ON — When this switch is set to On, serration pulses are present with sync signal output

OFF — When this switch is set to Off, serration pulses are not present with sync signal output

75 Ohm (input termination)

ON — 75-ohm input termination

OFF — High impedance input termination

Setting internal jumpers

The jumpers inside the interface(s) are set at the factory for optimal use by most systems. However, you can change a jumper setting to meet the needs of a particular system.

The user-configurable, internal jumpers control the following functions:

- horizontal and vertical sync polarity
- vertical sync pulse width.

Follow these steps to change the jumper settings. The RGB 134*x*_i is shown for illustration, but the steps apply to all interfaces.

1. Remove power from the interface by disconnecting the AC power cord from the unit.
2. Open the cover of the interface (the top half of the enclosure), as shown below. Remove the screws from the enclosure, and lift the cover straight up.

WARNING

Do not touch any switches or electronic components inside the interface. Doing so could damage the interface.

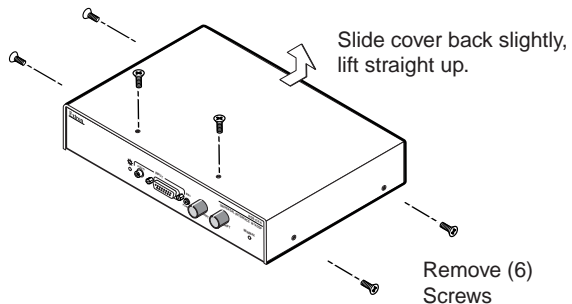

Figure 2-15 — Opening the interface cover

3. Note the positions of jumpers J20 and J40 before changing jumper settings. The illustration of the following circuit board shows the locations of the J20 and J40 jumpers. There are two possible setting combinations for 3-pin jumpers:

Controls and Installation, cont'd

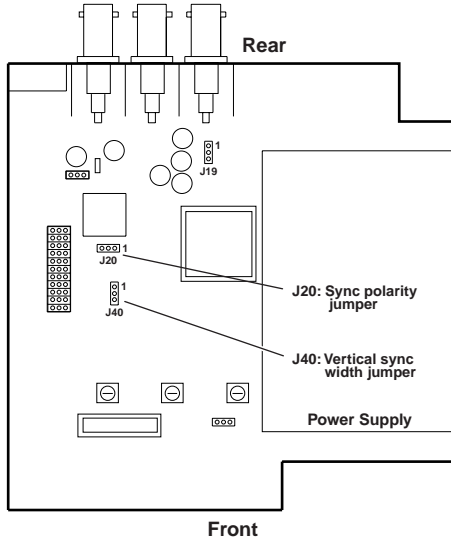
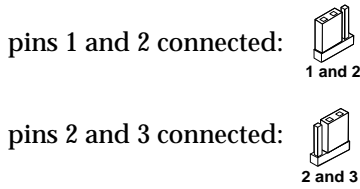

Figure 2-16 — Circuit board jumper locations

4. Configure the jumpers. To configure the jumpers, use pliers to pull the jumper shunt off the pins, then place the jumper on the appropriate pins.

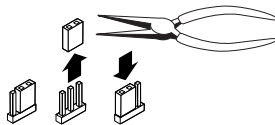
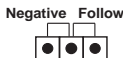

Figure 2-17 — Changing jumper settings

The jumpers perform the following functions:

J20: Sync polarity jumper — This jumper adjusts the output sync polarity. Horizontal (H) and vertical (V) sync output can either follow input sync polarity, or be forced to negative.



- If the jumper is placed on pins 1 and 2, output H and V sync polarities will be forced to negative.
- If the jumper is placed on pins 2 and 3, output sync polarity will follow input sync polarity: the output sync signal's polarity will be the same as the input polarity. This is the default setting.

J40: Vertical sync width jumper — This jumper adjusts the vertical sync pulse width. Some digital display devices have very specific requirements for incoming sync pulse width. If no picture displays, the picture cuts in and out, or the picture is scrambled, try adjusting the vertical sync pulse width or switching from ADSP™ to DDSP™.



- If the jumper is placed on pins 1 and 2, the output vertical sync pulse will be wide.
- If the jumper is placed on pins 2 and 3, the output vertical sync pulse will be short (narrow). This is the default setting.

5. Replace and fasten the enclosure cover, reversing step 2.



RGB 130*xi*, 134*xi*, 150*xi*

A

Appendix

Specifications

Accessories and Part Numbers

Mounting Templates

Appendix

Specifications — RGB 130xi, 134xi, 150xi

Video input

Number/type	1 analog RGBHV, RGBS, RGSB, RsGsBs
Connectors	1 15-pin HD male (150xi) 1 9-pin D male (130xi and 134xi)
Nominal level(s)	Analog — 0.3V to 1.5V p-p
Maximum level(s)	Analog — 1.5V p-p
Impedance	75 ohms or (for 130xi and 134xi) HI Z, switchable - set to 75 ohms if no local monitor is connected
Horizontal frequency	Autoscan 15 kHz to 125 kHz
Vertical frequency	Autoscan 30 Hz to 120 Hz
Return loss	-30dB @ 5 MHz
Maximum DC offset	4.0V

Video throughput

Gain	Unity, 0.725V p-p, 0.750V p-p
Bandwidth	300 MHz (-3dB)

Video output

Number/type/format	1 (2 if 134xi) analog RGBHV, RGBS, RGSB
Connectors	6 BNC (2 x 6 if 134xi) female 1 15-pin HD female localmonitor (150xi only) output (buffered)
Nominal level	Unity, 0.725V p-p /50% peaking, 0.750V p-p /100% peaking
Impedance	75 ohms
Return loss	-30dB @ 5 MHz

Sync

Input type	RGBHV TTL (\pm), RGBS TTL (\pm), RGSB 0.3V (-), RsGsBs 1.3V (-)
Output type	RGBHV (\pm), RGBS(\pm), RGSB (-)
Input level	2.0V to 5.5V p-p with ± 0.2 VDC offset (max.)
Output level	4.0V to 5.0V p-p
Input impedance	10 kohms
Output impedance	75 ohms
Max. propagation delay	48 nS

Max. rise/fall time	3.5 nS
Polarity	RGBHV: when RGBHV is input, polarity follows input; otherwise negative RGS, RGSB: negative

Audio input

Number/type	1 PC level stereo, unbalanced
Connectors	1 3.5 mm stereo jack, 2 channel; tip (L), ring (R), sleeve (ground)
Impedance	10 kohms, DC coupled
Minimum level	100mV
Maximum level	+8.5dBu, (unbalanced) @ stated %THD+N

Audio throughput

Gain	Unbalanced 0dB, balanced +6dB
Frequency response	±0.05dB @ 20 Hz to 20 kHz
THD + Noise	0.03% @ 1 kHz, 0.3% @ 20 kHz at rated maximum output drive
S/N	>90dB, output 14dBu, balanced
Stereo channel separation	>95dB @ 1 kHz to 20 kHz

Audio output

Number/type	1 stereo (2 channel), balanced/unbalanced
Connectors	3.5 mm stereo captive screw terminal, 5 conductor, for left and right output
Impedance	50 ohms, unbalanced, 100 ohms balanced
Gain error	±0.1dB channel to channel
Drive (600 ohm)	+14dBu, balanced at stated %THD+N

General

Power	100VAC to 240VAC, 50/60 Hz, 15 Watts, internal, auto-switchable
MBC power jack	9.0VDC, 150 mA
Temperature/humidity	Storage -40° to +158°F (-40° to +70°C) / 10% to 90%, non-condensing Operating +32° to +122°F (0° to +50°C) / 10% to 90%, non-condensing
Rack mount	No
Furniture mount	Yes, with optional kits, #70-077-01 and #70-077-02

Appendix, cont'd

Enclosure type	Metal
Enclosure dimensions of 130xi and 150xi	
.....	1.70" H x 6.35" W x 6.00" D
	4.32 cm H x 16.13 cm W x 15.24 cm D
Enclosure dimensions of 134xi	
.....	1.68" H x 8.70" W x 6.00" D
	4.26 cm H x 22.09 cm W x 15.24 cm D
Shipping weight	6 lbs (2.7 kg)
Vibration	NSTA 1A in carton (National Safe Transit Association)
Approvals	UL, CE, FCC Class A
MTBF	30,000 hours
Warranty	2 years parts and labor

NOTE *Specifications are subject to change without notice.*

Accessories and Part Numbers

Thunder™ Mounting Kits

Under desk mounting kit	70-077-01
Through desk mounting kit	70-077-02

Monitor breakout cables: RGB 130*xj* and RGB 134*xj*

MBC VGA/XGA HR	26-162-01
MBC Mac/Quadra	26-018-01
MBC SUN Sparc HR	26-424-01
MBC SGI/13W3 HR	26-425-01

Laptop breakout cables:

Laptop breakout cables are available in 3', 6', and 12' lengths with or without audio. Contact Extron for the specific cable for your application.

LBC VGA HR 6'	26-224-01
LBC Mac HR 6'	26-363-01
LBC SUN HR 6' (61 kHz)	26-413-01
LBC SUN HR 6' (71 kHz)	26-413-02
LBC SUN HR 6' (81 kHz)	26-413-03
LBC VGA HR 6' A	26-441-02
LBC Mac HR 6' A	26-442-02
LBC SUN HR 6' A (61 kHz)	26-443-02
LBC SUN HR 6' A (71 kHz)	26-444-02
LBC SUN HR 6' A (81 kHz)	26-445-02

Signal input cable kits for RGB 150*xj*

VGA 6' HR	26-112-15
VGA 3' HR A	26-491-01
VGA 6' HR A	26-491-02
VGA 12' HR A	26-491-03
Mac Adapter kit	70-078-01
Mac Adapter kit with Audio	70-078-02
13W3 Adapter cable kit	70-079-01
13W3 Adapter cable kit with Audio	70-079-02

Appendix, cont'd

BNC cables

BNC-5 3' HR	26-260-15
BNC-5 6' HR	26-260-01
BNC-5 12' HR	26-260-02
BNC-5 25' HR	26-260-03
BNC-5 50' HR	26-260-04
BNC-5 75' HR	26-260-16
BNC-5 100' HR	26-260-05
BNC-5 3' HRP	26-378-01
BNC-5 6' HRP	26-378-02
BNC-5 12' HRP	26-378-03
BNC-5 25' HRP	26-378-04
BNC-5 50' HRP	26-378-05
BNC-5 75' HRP	26-378-06
BNC-5 100' HRP	26-378-07

Miscellaneous

Output audio connector: five pole 3.5mm captive screw terminal	10-319-10
Installation cable: bulk 14 conductor, non-plenum	22-120-02
Installation cable: bulk 17 conductor, plenum	22-111-03

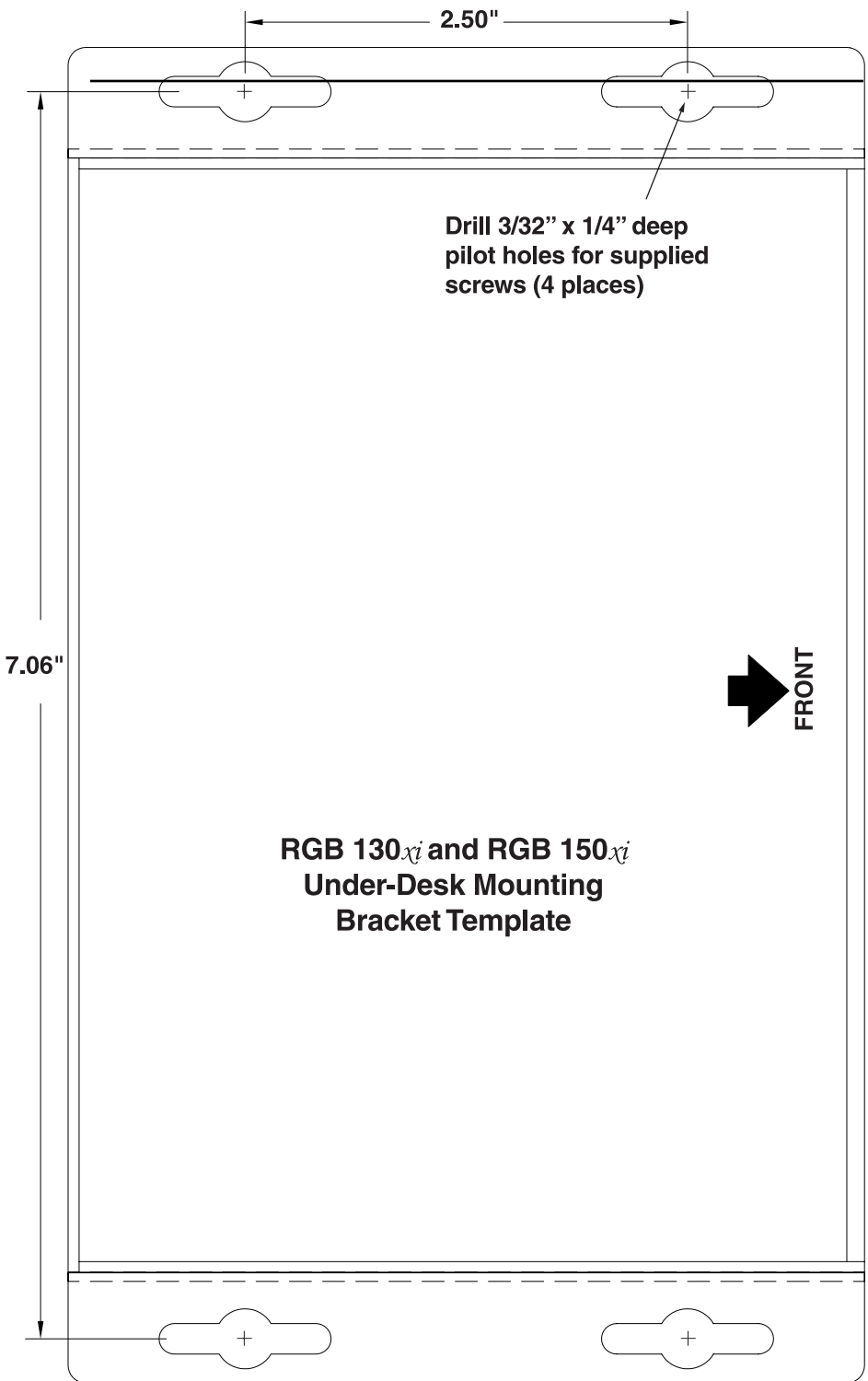

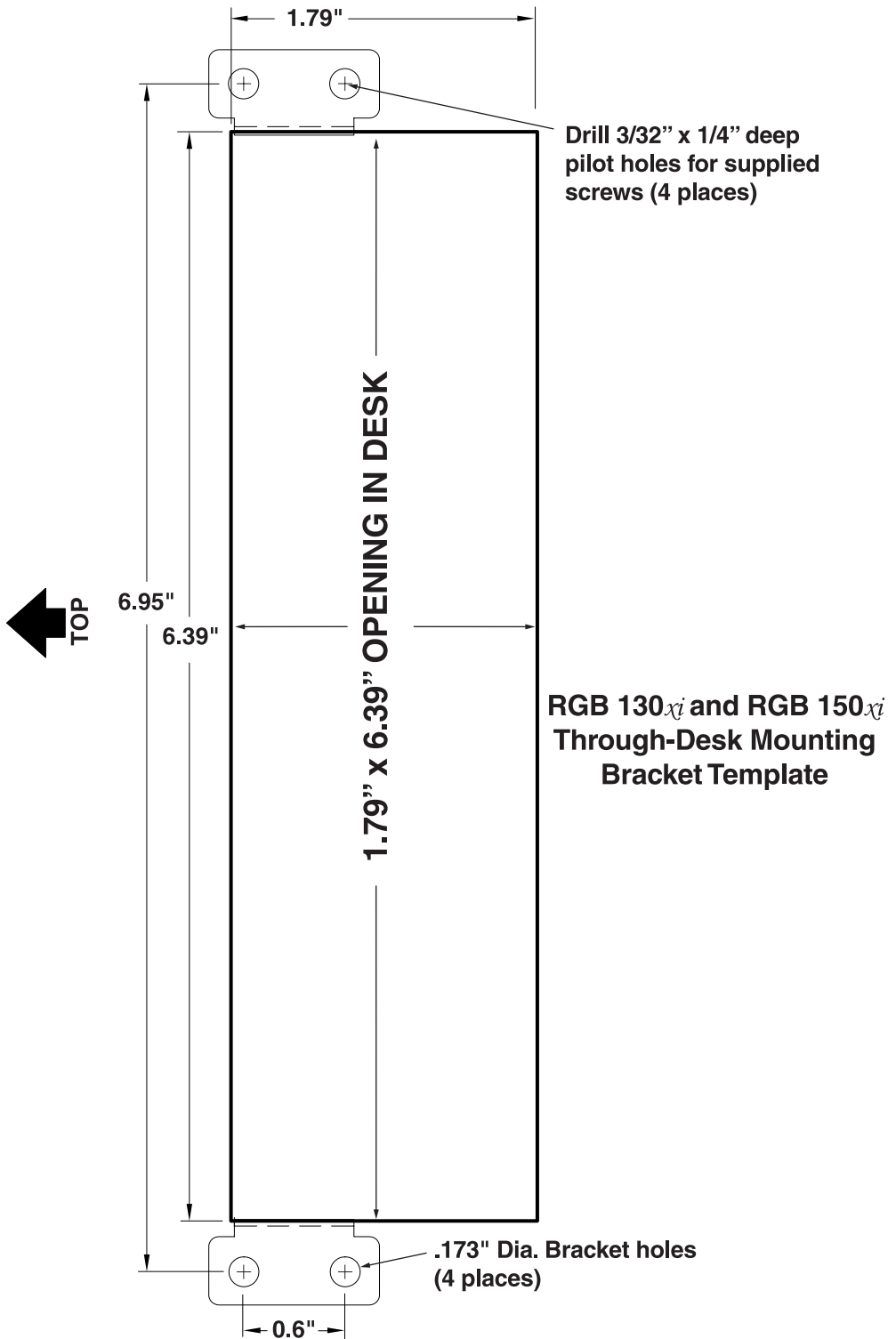

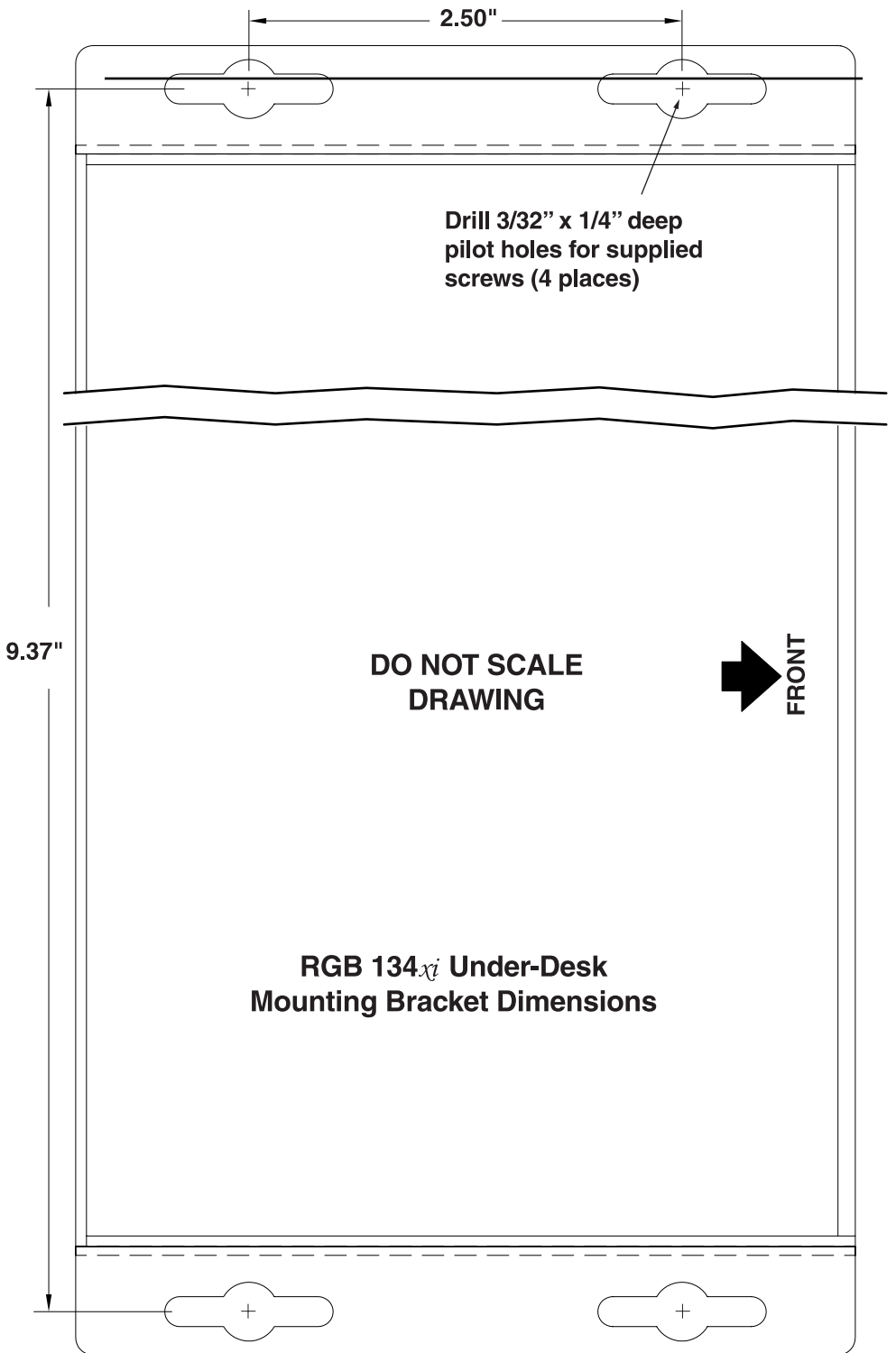

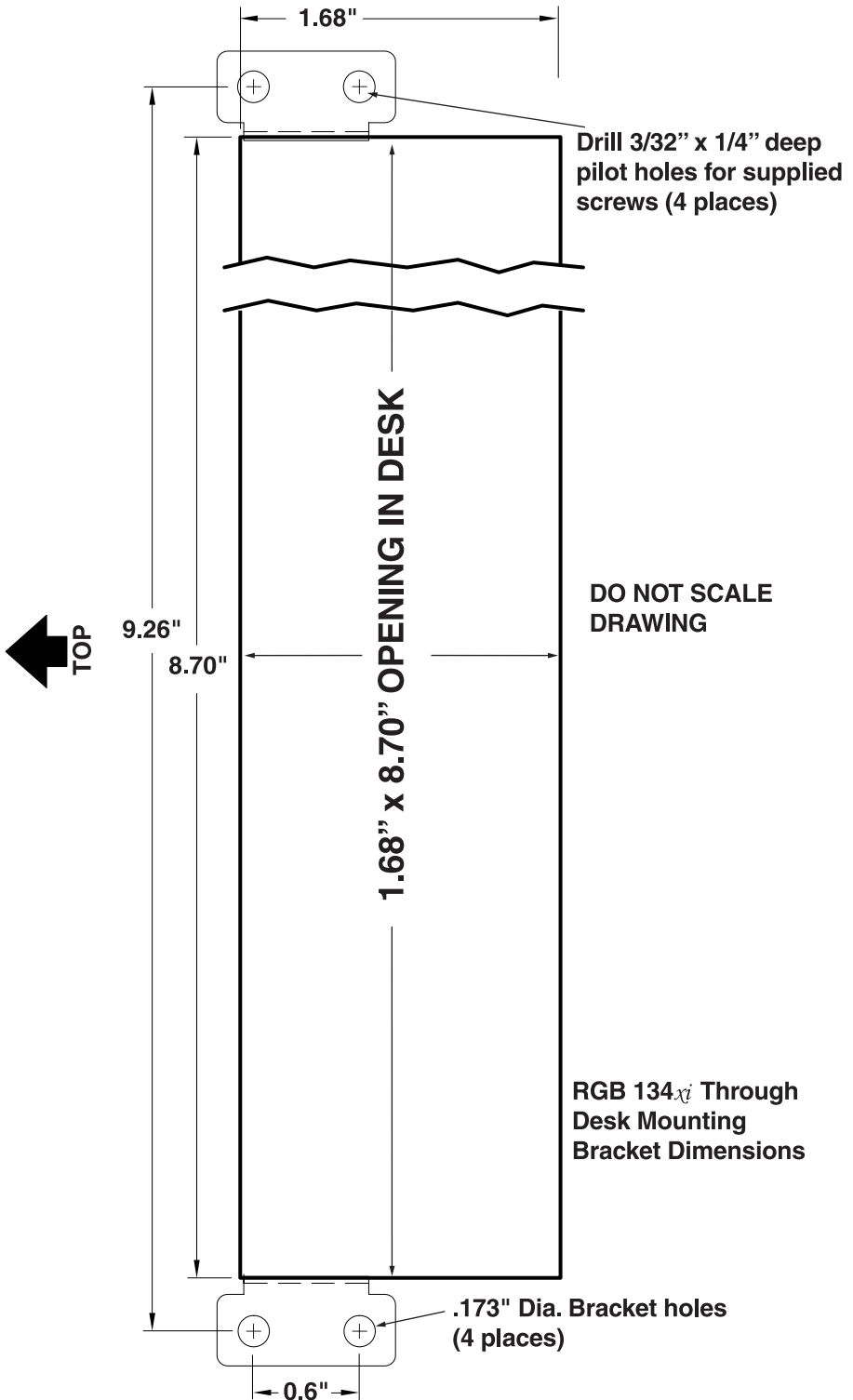

FCC Class A Notice

Note: This equipment has been tested and found to comply with the limits for a Class A digital device, pursuant to part 15 of the FCC Rules. These limits are designed to provide reasonable protection against harmful interference when the equipment is operated in a commercial environment. This equipment generates, uses and can radiate radio frequency energy and, if not installed and used in accordance with the instruction manual, may cause harmful interference to radio communications. Operation of this equipment in a residential area is likely to cause harmful interference, in which case the user will be required to correct the interference at his own expense.

Note: This unit was tested with shielded cables on the peripheral devices. Shielded cables must be used with the unit to ensure compliance.

Extron's Warranty

Extron Electronics warrants this product against defects in materials and workmanship for a period of two years from the date of purchase. In the event of malfunction during the warranty period attributable directly to faulty workmanship and/or materials, Extron Electronics will, at its option, repair or replace said products or components, to whatever extent it shall deem necessary to restore said product to proper operating condition, provided that it is returned within the warranty period, with proof of purchase and description of malfunction to:

Extron Electronics
1230 South Lewis Street
Anaheim, CA 92805, U.S.A.

This Limited Warranty does not apply if the fault has been caused by misuse, improper handling care, electrical or mechanical abuse, abnormal operating conditions or non-Extron authorized modification to the product.

If it has been determined that the product is defective, please call Extron and ask for an Applications Engineer at (714) 491-1500 to receive an RA# (Return Authorization number). This will begin the repair process as quickly as possible.

Units must be returned insured, with shipping charges prepaid. If not insured, you assume the risk of loss or damage during shipment. Returned units must include the serial number and a description of the problem, as well as the name of the person to contact in case there are any questions.

Extron Electronics makes no further warranties either expressed or implied with respect to the product and its quality, performance, merchantability, or fitness for any particular use. In no event will Extron Electronics be liable for direct, indirect, or consequential damages resulting from any defect in this product even if Extron Electronics has been advised of such damage.

Please note that laws vary from state to state, and that some provisions of this warranty may not apply to you.



EXTRON ELECTRONICS/RGB SYSTEMS, INC.
1230 South Lewis Street, Anaheim, CA 92805
800.633.9876 714.491.1500 FAX 714.491.1517
USA

EXTRON ELECTRONICS, EUROPE
Beeldschermweg 6C, 3821 AH Amersfoort
+31.33.453.4040 FAX +31.33.453.4050
The Netherlands

EXTRON ELECTRONICS, ASIA
41B Kreta Ayer Road, Singapore 089003
+65.226.0015 FAX +65.226.0019
Singapore

EXTRON ELECTRONIC INFORMATION
EXTRONWEB™: www.extron.com
EXTRONFAX™: 714.491.0192
24-hour access — worldwide!